

MODERN RADIO RECEPTION

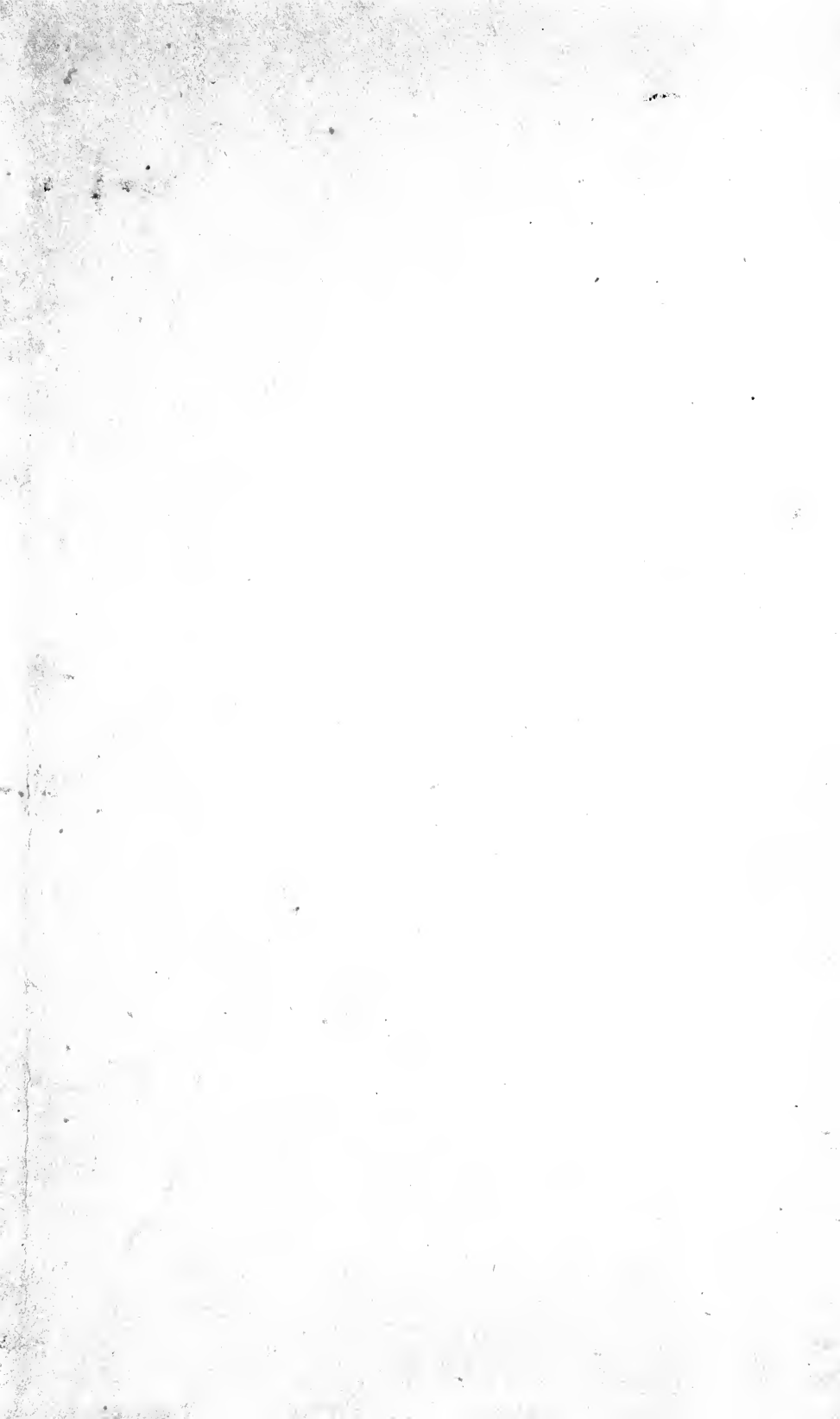

BY
CHARLES A. LEUTZ

1928 Edition



From the collection of the

o P^zreⁿinger^m
v L^aibrary
t p

San Francisco, California
2006



*MODERN RADIO
RECEPTION*



BY

CHARLES R. LEUTZ



Published By
C. R. LEUTZ INC.
NEW YORK
1928

Copyright, 1928
CHARLES R. LEUTZ
Forest Hills, N. Y.

Printed and bound by
WM. C. POPPER & Co.
New York, N. Y.
U. S. A.

PUBLISHERS NOTE

It is obvious that one book could not cover all the different types and makes of radio receivers and accessories. This book has been confined to what is believed the most important and interesting apparatus at the present time.

The publishers of this book, unlike strictly publishing firms, have an Engineering Force and Experimental Laboratories, and they welcome inquiries for supplementary information to this book.

C. R. LEUTZ INC.
Long Island City, N. Y.

PREFACE

The first edition of "Modern Radio Reception" was published in 1923 and a second edition published in 1924.

This present exposition of the field of Broadcast Radio Reception issued in 1928 is an entirely revised and rewritten volume. During the past three years, broadcasting conditions are entirely different, most of the transmitters and receivers used a few years ago are now obsolete. Rather than devote space to apparatus of historical interest, this book deals principally with all the latest developments which is what the majority of the experimenters or broadcast listeners demand.

To make the book most useful to the large majority of the readers it has been made as non-technical as possible, the mathematical equations confined to simple examples, and the descriptions of the apparatus given in an easily understandable manner.

Several thousand owners of radio receivers designed by the writer have offered suggestions which are covered in this book and the author wishes to express indebtedness for their assistance and also from the following firms; (among others)

General Radio Co.
Institute of Radio Engineers
General Electric Company
E. T. Cunningham Inc.
A. H. Grebe & Co.
NEMA Standards
Weston Elec. Inst. Co.
Western Electric Co.
Ward Leonard Electric Co.

Readers who are seriously interested in the future of the radio field should join the Institute of Radio Engineers. This is a non-profit organization which includes in its membership all the leaders of the radio industry. Papers are issued monthly covering all the latest developments in radio in the form of "Proceedings of the Institute of Radio Engineers." In addition to the main meetings in New York there the Sections in Toronto, Chicago, Middletown, Conn., Los Angeles, Philadelphia, Rochester, San Francisco, Seattle and Washington where monthly meetings are held. Further information can be obtained by writing to the Secretary I.R.E., 37 West 39th Street New York City.

CHARLES R. LEUTZ.

CONTENTS

Radio Reception

The Antenna
Loop Antenna
Ground and Counterpoise
Inductances
Condensers
Resistors

Radio Laboratory Apparatus

Measuring Devices
Radio Oscillators
Audio Oscillators
Tube Reactivators
Battery Chargers
Coupling Methods
Audio Amplifiers

Radio Receivers

Western Electric Super-Heterodyne
Grebe Synchrophase
Transoceanic Silver Ghost
Transoceanic Phantom
Frequency Changers
B—C Current Supplies
A Current Supplies
Short Wave Reception
Broadcast Reception

Radio Tube Data

Radio Standards and Definitions

CHAPTER I

RADIO RECEPTION

The actual manner in which the transmitted electrical signal travels from the transmitting station to the receiving station is a highly technical discussion. There are several different explanations and these theories vary with the different wavelengths propagated. The main consideration from the receiving standpoint starts with the signal reaching the antenna.

ANTENNA

An antenna is usually referred to as the aerial wires, lead-in and ground system complete, the aerial is simply the elevated wires of this system. For reception there are three distinct types, vertical, horizontal and inclined aerials. During a considerable amount of experimenting it has been found that the height of the antenna is the most important consideration, and will result in collecting the greatest amount of received signal energy. In technical terms, engineers always refer to the effective height of the antenna, roughly this is the average height from the ground. For example a vertical antenna 100 feet high would only have an effective height of approximately 50 feet. A horizontal antenna in which the flat top length is great in proportion to the height will have directional properties, that is it will receive better from one point than another. This will not be so noticeable where the lead-in is taken from the center (T type) as with the lead-in at one end (L type). With the lead-in at one end the signals are received best from the direction of the lead-in end. The directional qualities of the antenna depend upon the wave form received and this is influenced by the character of the topography at the antenna location. The antenna should have the lowest possible high frequency resistance, and this does not simply mean soldered joints and good insulators. Objects in the field of the antenna add to the high frequency resistance. For example the antenna may run down the side of a steel building, run near trees, water tanks, telephone wires, etc., which would increase the high frequency resistance. The ground connection may be made to pipes which have corroded joints before reaching the ground, or the pipes may enter dry sandy soil which would prove an inefficient ground resulting in increased high frequency resistance which would seriously detract from the selectivity of tuning and amount of signal energy received.

The usual antenna erected for broadcast reception consist of a single wire antenna stretched between the two most convenient supports readily obtainable, regardless of any other considerations. In the eastern states, for some unexplained reason it is found that reception from the south is generally better than from the west. With this in mind it has been found that aerials running east and west have given the best average results not only from the west but also as well from the north and south. The lead-in end should be toward the west if an "L" type antenna. A better arrangement would be to have two aerials, one east and west one north and south, each crossing the other and the lead-in taken from the point of intersection. The flat top of each should be as high as possible and each about 150 feet in length. This would be an ideal distance getting antenna without any decided directional properties. It must be remembered that such an antenna would only be suitable for a receiver having a high degree of selectivity such as the Silver Ghost or Transoceanic "Phantom."

Every antenna has a Fundamental Wavelength or natural period as it is called, this is determined by the Capacity and Inductance of the antenna which in turn are determined by the height, length, number of wires, form, surrounding objects, etc. For example a long antenna 2000 feet in length might have a fundamental wavelength of 600 meters. Accordingly without some means of reducing this wavelength at the receiver, it would be impossible to efficiently receive wavelengths below 600 meters. However such an antenna has resonant effects at

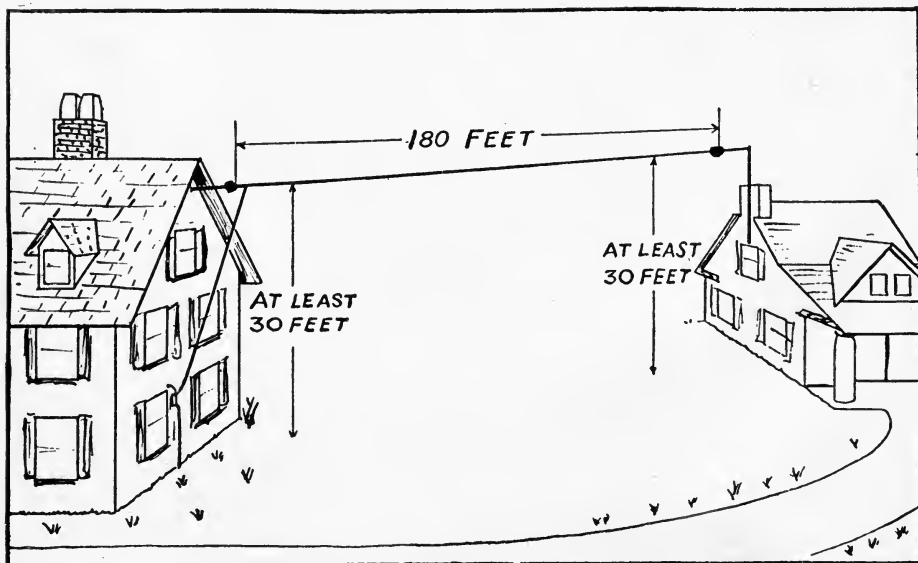

Fig. 1

periods below the fundamental, such as 300 meters, 150 meters, 75 meters, etc., and these wave effects can be used to receive these peak wavelengths to decided advantage. For transoceanic reception some of the aerials are seven miles long.

On the other hand while a long antenna is suitable for both long and short wavelengths, a short antenna is not efficient for long waves.

To receive wavelengths of 2500 meters and higher an antenna 1000 feet long is to decided advantage. Four wires each 250 feet long, each wire separated only a few feet are not anywhere near equal to a single 1000 feet antenna unless the four wire aerial has considerable height.

A very popular form of antenna is the cage type. Instead of a single wire, five or six wires are used all running parallel and equally spaced around hoop separators. The diameter of these hoops vary from about eight inches for receiving work to several feet for transmitting antennae. At each end of the parallel wires merge into one wire. Where the T type cage antenna is used, the lead-in is sometimes also in the form of a cage. In erecting an antenna, the aerial and lead-in wires should be soldered at all joints, the wires should be well insulated at points of suspension. If any long guy wires are used to support the antenna, these guy wires should be broken up every 25 or 50 feet with a strain insulator. This prevents the guy wire from absorbing energy at the guy wires natural period, or fundamental wavelength, the guy being broken up having no fundamental period.

The ground connection is very important, the usual connection is made to the steel frame of a building, water pipes, gas pipes, electric conduits, etc. Some have tried to use flower pots. Where it is not convenient to connect to any pipes, a suitable ground connection can be made by running a wire to a piece of brass or iron pipe six feet long, this pipe in turn being driven into moist earth. In the absence of moist earth, it is better to use a Counterpoise, this consisting of a wire running parallel to the aerial, either raised a few feet above the earth, laying on the earth or buried under the earth a few feet. This is the form of ground usually employed for portable receivers or even transmitters.

With a receiver located several stories high in a tall building the question arises as to the length of the ground wire. The ground wire should be as short and direct as possible. A few years ago the writer had an experimental receiver located on the twenty-third story of the Candler Building, 42nd Street, New York. According to theory the ground wire would be 350 feet long. However, imagine that the building was buried in a large hill, the twenty-third story being at the top of the hill, the ground wire would then only be a few feet

long. Judging from the results obtained, which were very satisfactory, the ground wire is not much longer than to the point where it connects to the steel frame of the building, particularly as far as receiving conditions are concerned.

From this location by dropping an insulated wire out of the window down about ten stories very fine west coast reception was obtained on a Model L Super-Heterodyne, the receiver available at that time (1923).

LOOP ANTENNA

For the regular broadcast wavelengths of 200 to 560 meters the average loop obtainable is considerably more inefficient than an antenna as far as collecting signal energy is concerned. A loop has one advantage and that is that a loop will only receive a certain direction.

The maximum signal energy is collected by a loop when the plane of the loop coincides with the line joining the center of the loop and the transmitting station being received. That is a loop receives from the two direction it points. On the other hand if the loop is at right angles to the transmitting station, and the loop leads are not unduely long, no signal energy will be received at all. Accordingly if two stations are transmitting on exactly the same wavelength, but are located at right angles with respect to the receiving loop, it

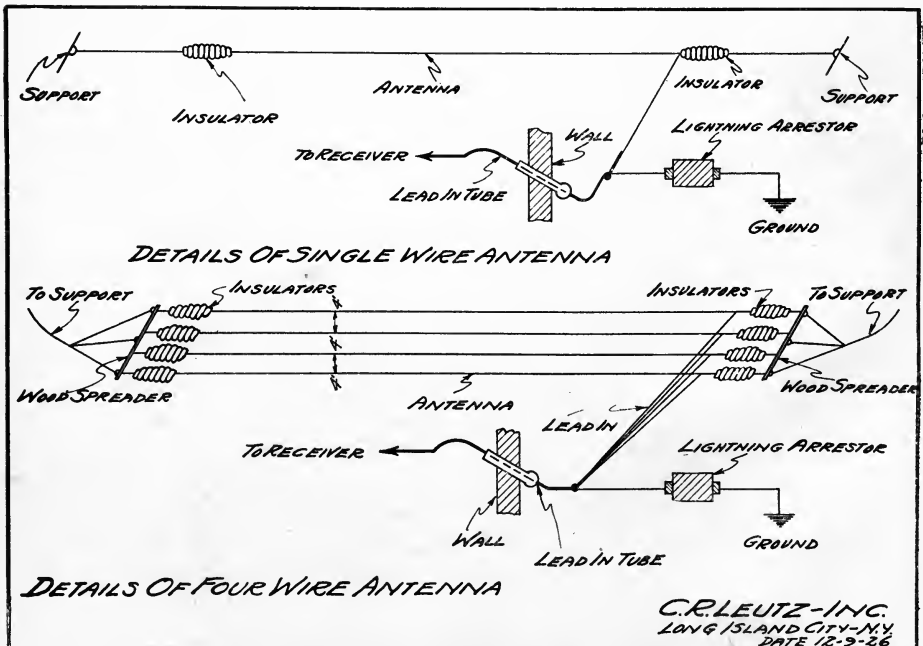

Fig. 2

is possible to select between the two stations even though they are both on the same wavelength. Using an antenna this would be impossible.

However the loop for ordinary wavelengths has many disadvantages. In the first place for a loop to have an efficiency approximating an antenna, the loop would have to have practically the same dimensions. That is the loop would have to be 35 feet square to equal antenna about 150 feet long. Such a loop is not a convenient instrument and as the size is reduced to more reasonable proportions, the efficiency drops off rapidly. A loop four foot square is four times as efficient as a collector as a loop only two foot square. For very short wavelengths below 50 meters a loop will compare favorable for a short antenna as a collector.

In actual operating conditions on the broadcast band it is true that it requires two or three of the tuned radio frequency stages of the receiver to compensate for using an average loop. The comparison would then be that a four radio frequency stage receiver on a loop would only be equal to a two stage frequency receiver working on an average antenna. It is obvious that for maximum range an antenna will give best results.

The successful operation of a loop also depends upon the various objects surrounding the loop. As an experiment, if the loop was entirely enclosed in a metal box, it would be impossible to receive any signals as the loop would be completely shielded.

Likewise if the loop was in a room where the walls were plastered over steel mesh there would be partial shielding which would greatly reduce the signal strength received. Other objects such as steel buildings, water tanks, bridges, wet trees, etc., located near the loop and and in line with the transmitting station tend to partially shield the



Special Loop Receiver.

Fig. 3

loop and reduce the signal strength received. Usually an antenna can be raised higher than these obstructions which will eliminate such losses as just described.

Loops are used as direction finders, however during this operation it is impossible to find an accurate direction by figuring on the direction the loop picks up maximum signals strength as the signal strength remains strong over quite an arc of rotation of the loop. By adjusting the loop for minimum signal (right angles to the line of reception) the point of direction is very sharply defined, but of course at right angles to the line of the transmitter. The loop operates equally well if rotated 180° (one half turn) from the point of direction located, so it is impossible to determine the general direction unless information is on hand. In order to determine the location of a station of unknown position, two or more loops, located some distance apart are necessary. The distance between the two loops being known and the bearings of each recorded and interchanged the exact location of the received station can be plotted on a map. Experiments show that signals picked up on a loop, the signals having traveled several thousand miles, sometimes approach the loop at a different direction than expected. This deflection could be due to the conditions that the waves encounter over such great distances, water, mountains, etc.

A loop has definite wavelength range, the exact range depending upon the inductance of the loop and the capacity of the tuning condenser, an average loop might tune from 200 to 560 meters with a .0005 MF condenser. This loop would not be suitable to receive shorter or longer wavelengths efficiently.

To cover a wavelength range of 35 meters to 3600 meters a series of five different loops would be required, accordingly an antenna would be more suitable and convenient. To provide a loop with taps to cover a wide wavelength range would be very inefficient due to the deadend losses (unused parts of loop hanging connected) or even if the unused part of the loop was disconnected this wire in the field of the loop wires being used would prove detrimental.

INDUCTANCES

Every tuned radio circuit is made up of three parts, Inductance, Capacity and Resistance. The inductance consist of the tuning coil or transformer secondary and leads connecting to same. The capacity consists of the tuning variable or fixed condenser and also the capacity due to the connecting leads being close to each other. The resistance may be a resistance unit or the resistance of the Inductance and Capacity.



Fig. 4
Typical
Solenoid
Inductances.

Considering the inductance alone, the main consideration is usually first to cover the proper wavelength range. If the inductance is too small it will not properly tune to the higher wavelengths and if too large will not tune down to the lower wavelengths desired. After the proper size inductance is determined the next important consideration is to provide an efficient inductance, one with a minimum of losses so that the tuning circuit will be selective or in the case of a transformer secondary so that the amplified energy will not be wasted by absorption. The losses are due to several factors including the distributed capacity of the coil, material and shape of supporting form, size and material used for the wire, shape of coil, distribution of the turns, frequencies used, etc. For all ordinary purposes, especially in broadcast it has been found that simple solenoid single layer coil is the most efficient. The amount of distributed capacity found is due to the effect between the adjoining turns of the coil. For example consider a 50 turn coil, if this is wound in a single layer the ends will be a considerable distance apart and the capacity effect small. If the 50 turns was divided in to two layers, 25 turns over and 25 turns back the ends of the coil would meet and the capacity effect would be great. If the 50 turns were wound by winding 25 turns over, one turn back and 24 turns over, the capacity effect would be considerably reduced, this is called bank winding. Measuring the distributed capa-

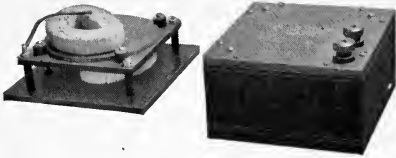

Fig. 5
Laboratory Inductance
Standard.



Fig. 6
Two Inductances with
variable coupling.

city of any of the above coils after winding and then varnishing the coil and measuring the distributed capacity again it would be found that the distributed capacity had increased considerably. Likewise if a variable condenser or any other metal object was placed near the coil it would be found that the distributed capacity had increased again. Accordingly in receiver design it is necessary to use coil varnishes that add a minimum amount to the distributed capacity and so locate the inductances that they are not so close to surrounding objects to cause serious losses. Any increase in distributed capacity means an increase in high frequency resistance and subsequent broad tuning and loss of signal strength.

It was originally believed that the more surface presented to the high frequency currents that the minimum losses would be encountered and this is more or less true in regard to transmitters. In receiving inductances it has been found that very small wires can be used with not only equal but superior results to that obtained with larger wire or Litzendraht. Litzendraht is more suitable for wavelengths above 200 meters. Litzendraht is a flexible wire made up of a number of smaller wires, each of the wires being insulated from each other, this construction providing considerable surface compared with a solid wire of the same diameter. However this wire is very difficult to handle and solder without damage due to the small diameter of the individual wires and sometimes due to the large number of wires that are broken while winding the coil, the results are no better than the proper size solid wire.

Where space permits, the distributed capacity of a coil can be reduced considerably by space-winding the coil, that is instead of each wire wound tight against the previous turn, a space is left between turns. This system has the additional advantage of enabling induc-

ance to be wound to an exact value. In close winding the insulation and wire thickness varies and it causes a certain number of turns to occupy a varying space resulting in a low fundamental wavelength. If this wavelength is within the tuning range of the receiver, the receiving results around that wavelength will be very poor. Furthermore if the distributed capacity is high, it may be a considerable portion of the value of the tuning condenser at the low end of the condenser and results would be very poor at that point. The high frequency resistance value varies with frequency usually increasing with increase in frequency.

In some receiver designs an inductance of certain size is used for one wavelength range and then a portion of the inductance short-circuited to obtain a lower wavelength range. This is very dangerous design practice and unless great care is used it is possible that the un-

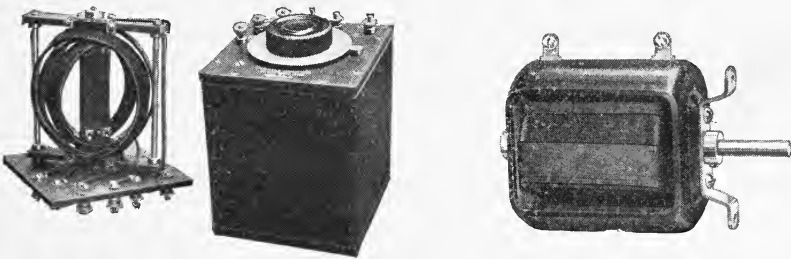

Fig. 7

Variable Inductances.

Fig. 8

used portion short circuit causing distributed capacity will give the entire inductance a wavelength period within the lower wavelength range to be tuned. This shorted portion may also have a "trap" effect for the shorter wavelengths to be tuned. The superior method, specially in tuned radio frequency transformers is to switch the entire transformer out of circuit and replace with an entirely different transformer for the shorter wavelengths.

An ordinary solenoid inductance has a strong field. Two such solenoids close to each other and either parallel or concentric would interfere with each other causing parasitic coupling if both were used in the same circuit, viz., a radio frequency amplifier. This interaction can be prevented by placing the coils at right angles to each other, or by shielding. An inductance can be wound to have little or no external field, so that two such inductances would have no interaction. However in order to wind such an inductance, the windings have to be arranged in such a manner that the distributed capacity and other

losses are prohibitively high. One form of confined field inductance is to have two solenoids side by side. Another is the "Doughnut" winding bent into a circle having the ends meet. All these forms, while presenting the minimum external field desired, have such high distributed capacities and other losses that they cannot be used in receiver designs where maximum efficiency must be obtained.

CONDENSERS

A condenser is an instrument designed to have electrostatic capacity and in the case of radio equipment, with lowest possible losses. The usual construction consists of two metallic surfaces separated from each other by an insulating material. This insulating material is called the dielectric, it may be air, mica, glass, paraffin paper or other insulating materials. The capacity of the condenser is determined by the surface of the metallic plates opposing each other, the distance between plates, the thickness of the dielectric and the material of the dielectric. The condenser is used in both radio and audio frequency circuits. The most common use is with connection with an inductance, to tune a definite wavelength range. Direct current will not pass through a perfect condenser. Alternating current will pass through condensers. Accordingly where condensers are used to stop direct current they are termed stopping condensers and where they are used to shunt alternating currents they are called by-pass condensers. Condensers are also used for a great variety of purposes including reservoir condenser and filter condensers in B battery eliminators. The condenser may either have a fixed value or be variable. The capacity does not change with frequency although in a poor condenser the losses do change materially with frequency.

Some years ago a condenser was used with a compressed air dielectric. This condenser had the advantage of self-healing, that is if the high voltage used punctured the compressed air, no damage was done as the air immediately renewed the space punctured. Some paper dielectric condensers are also constructed to have a self-healing feature. The metal surfaces used to secure the capacity are unusually thin. If the paper is punctured by excessive voltage, the heat quickly melts the metal over a surface considerably larger than the hole punctured in the paper dielectric and the short circuit is immediately broken.

The ordinary variable condenser has a set of stationary or stator plates and a set of rotary or rotor plates, so arranged that when the rotor plates are intermeshed with the stator plates the capacity is increased (the capacity being increased as there is an increase in sur-

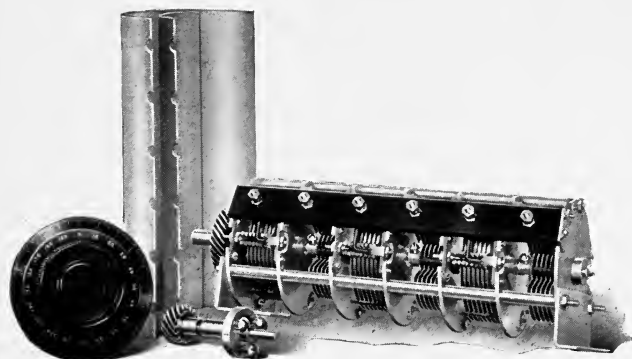

Multiple
Condenser.

Five Condensers
on One Shaft,
Covered by
Hogan Patent
1,014,002.

Note shielding
between Stators.

Fig. 9

faces opposing each other. If the rotor plates are semi-circular the increase in capacity is in direct proportion to the angular displacement of the rotor shaft. In tuning circuits a condenser having a straight line capacity curve (semi-circular plates) would crowd all the lower wavelengths closely together. For this reason the rotor plates are specially shaped so that the capacity increase is at first slow and then increases regularly, such a condenser is called a straight line wavelength condenser, that is if the wavelength range is plotted against angular movement of the rotor plates the resultant graph will be a straight line. By arranging the rotor plates to a special shape the plotted line can be made straight line frequency instead of straight line wavelength. For broadcast reception work a compromise between straight line wavelength and straight line frequency is the most satisfactory. It must be remembered that a straight line frequency condenser will not tune any sharper than a straight line wavelength condenser, it will simply separate the received station further apart on the dials, not further apart from interfering with each other.

In a variable condenser the dielectric is usually air which has a constant of 1. If this condenser was filled with Castor Oil which has a dielectric constant of 4.67 the capacity would be 4.67 times the original capacity. In a variable air condenser there are several important considerations in the design, one of these is the location of the stator insulators and another the material the insulator is made out of. Early condensers had a metal end plate and an insulating bushing for the rotor shaft which was the poorest type of design. The superior method is to insulate the stator plates at the metal end plates where the field is the weakest and losses at a minimum. The insulating material for the stators should be porcelain, glass, quartz or hard rubber because all these have the very lowest dielectric losses. The importance

of low dielectric losses will be appreciated from the following data when the condenser has a perfect dielectric and is charged from a steady voltage supply, the charging current will flow for an instant only; the condenser taking the charge instantly. Now if the condenser is discharged, the discharging current will also reach zero instantly, and the condenser will be entirely discharged. On the other hand if the dielectric is imperfect it will take a longer time for the condenser to charge and discharge, this time being occupied by the charge soaking into the dielectric and draining from the dielectric. If the condenser is large it can be given a quick test by charging it with a source of direct current around 100 volts. After the condenser is charged it can be discharged by short circuiting it with a wire, a thick spark being obtained. If the condenser is of good quality there will be only one spark for the entire discharge. If there is a second spark or discharge available a few moments later upon short circuiting the condenser again, it indicates that a charge has drained out of the dielectric (residual charge) and that the dielectric is inefficient (usually called an absorbing dielectric). Such absorption represents a loss of electrical energy as it results in a generation of heat in the dielectric and should be entirely avoided in the design of a good condenser.

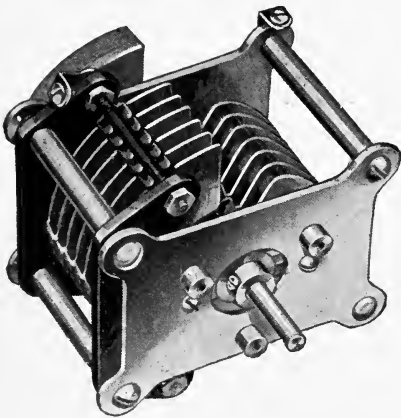

Fig. 10

Condenser with wide spacing to stand high voltages between rotor and stator plates.

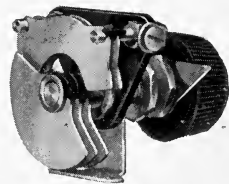

Fig. 11

Vernier Condenser, used to obtain a fine adjustment on a larger condenser.

SHIELDING

In multi-stage amplifiers, particularly radio frequency amplifiers it is desirable to eliminate all coupling from one stage to the other stages, in other words, between stages. Where only three radio transformers are used and considerable space is available, the coupling can be greatly reduced by simply having the transformers at right angles to each other and proper arrangement of the connecting leads. Where, four, five and six transformers are used, shielding can be used to reduce the coupling or interaction. The reduction in coupling is desirable as it enables the amplifier to be operated at the highest point of efficiency.

It should be pointed out that simply placing the radio frequency transformers in metal compartment, separating one transformer from the other is not scientific shielding. Judging from the shielded receivers shown at the 1927 radio shows, the inside details of efficient receiver shielding do not seem to be generally known. As a matter of fact some shielded receivers now available would be a great deal more efficient without the shielding, that is the shielding instead of being an improvement is an actual detriment.

A perfectly complete shield is practically impossible, but with proper application sufficiently efficient shielding may be obtained to prevent certain undesirable effects. Insulating materials such as Glass, Mica, Rubber, etc., have practically no effect of shielding a magnetic field. To shield plain magnetic fields of low frequency, thick metal must be used, for a stationary magnetic field iron of considerable thickness must be used. In general the shielding properties of metal screens increase in effectiveness with increase in frequencies. At radio frequencies, the currents flowing are limited to a small depth of the shield, so a thin piece of metal is satisfactory. In general Silver, Aluminum and Copper provided the best shields at radio frequency in the order mentioned. In designing shielding for receivers, the separation of the magnetic fields is easier to accomplish rather than isolate the radio frequency currents. It must be remembered that even the smallest amount of metal shielding placed near a radio inductance or radio frequency transformer will immediately change the radio frequency resistance of these coils. As it is necessary that the radio frequency resistance be kept at the absolute minimum, the shielding must be so placed as to give the desired screening and still add an absolute minimum of high frequency resistance. The increase in resistance depends upon how the coil is located in relation to the shielding surfaces and where the electrical-connections are made between the coil and shield. The greatest part of the increase in radio frequency

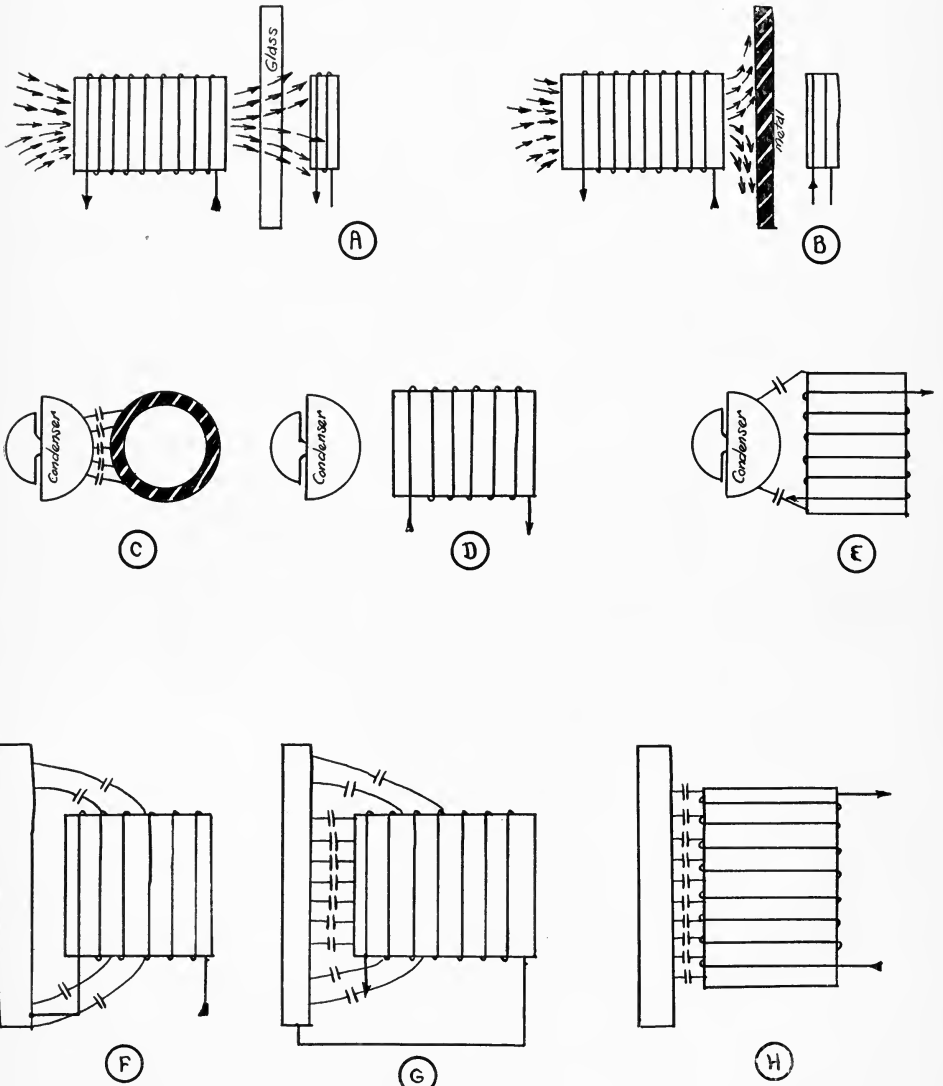

Fig. 12

is due to an increase in distributed capacity of the coil. Inductance or transformers designed for use without shielding are entirely unsuited for use in connection with shielding due to the change that takes place in the inductances after adding the shielding, accordingly inductances or transformers for use with shielding should be developed in the actual shielding arrangement desired.

The distance and relation between a tuning condenser and inductance is of great importance. If the distance between these two units is 3 or 4 inches the changes in the coil due to the condenser will be small. On the other hand if the coil is near the variable condenser, the changes are of considerable effect, partly due to the increase of resistance in the inductance and partly due to the eddy currents set up in the metal portions of the condenser. Referring to Figure 12 the increase in capacity is noted in C, D and E, in this case the eddy current losses was greatest in D while the increase in capacity was greatest in E and C. The capacity effect due to the inductance near a metal shield is shown in F, G and H. F and G are exactly the same situation but in F the low potential end of the coil is connected to shield, this end near the shield and the capacity effect is then at a minimum. The effects between different shaped coils and shields have a still different effect usually more on the undesirable side. To give an idea of the change in inductance with shielding it is pointed out that a variable inductance can be constructed by winding a flat spiral coil and covering it on one side with a piece of copper. By slowly removing this piece of copper, sliding it across the coil, the inductance increases. Such variable inductances were used in a transmitting set some years ago but the losses were of high order as the presence of the copper raised the radio frequency resistance of the inductance to an unreasonable value.

In shielding for radio frequency circuits the following points must be remembered: 1. Do not use magnetic metals. 2. Connect filament end of inductances to the shield and have this end closest to the shield. 3. Leave maximum possible space between grid end of inductances and the shield or other mettalic object such as the variable condenser. Supplementary to good shielding the arrangement of the wiring is of importance, the grid and plate wires should be as short and direct as possible. Running the grid and plate wires of one tube parallel and close together would be exactly the same as adding a small conser around the grid and plate of the tube. Running the grid wire of one tube parallel to the grid wire of another tube would be exactly the same as connecting the two grids together with a small condenser which would couple them together causing regeneration or oscillations in the case of an amplifier.

THE INCREASING USE OF RESISTORS IN RADIO

Until a short time ago the fixed resistor occupied a position of unimportance in broadcast receiver work. True, fixed resistances were used, but they were of the type that limited their value to work where small loads were imposed. Carbon-coated paper and the composition resistor practically dominated the radio field. There were a number of applications for the current carrying noiseless resistor of the Vitrohm type, but these uses were found mostly by the radio experimenter.

The radio public first had its attention turned to the importance and value of good resistors when the current supply unit and high voltage power amplifier arrived. Then they searched for resistors suitable for this class of work, for poorly constructed and inaccurate resistors will not stand up in this service.

Battery eliminators, power amplifiers, and combination amplifier-eliminators have driven home emphatically in the public mind the importance of good resistors in relation to perfect reproduction of broadcast programs. The most brilliant prophet in radio matters cannot predict how far refinement and improvement in this field will go. This much is a proved certainty: fixed resistors will play a still more important part in the advance towards apparatus which will give us the ultimate in clear broadcast reproduction as experimenters learn true resistor values.

It is a significant fact that as current supply units have improved, so has the quality of reception improved. The resistor is the determining factor in the performance of the supply unit. This point is now recognized by the engineers doing most for radio development today.

THE WIRE-WOUND, VITREOUS ENAMELLED RESISTOR

Although it is scarcely a year since serious thought and attention on the public's part has been given to the applications of resistors in radio work, electrical engineers have used resistors extensively for many years. All the experimenting that radio engineers are doing today to find satisfactory, economical resistors is a duplication of electrical history. The electrical industry settled the question years ago, and finally adopted a wire-wound resistor, with the wire embedded in enamel, as the only resistor that would not deteriorate or change in resistance with use. Over a third of a century ago, H. Ward Leonard perfected an embedded type resistor that possessed all of the advantages which others had sought in vain, and which was free from the disadvantages considered inherent in earlier type resistances.

A number of methods had been tried even prior to 1890 whereby a

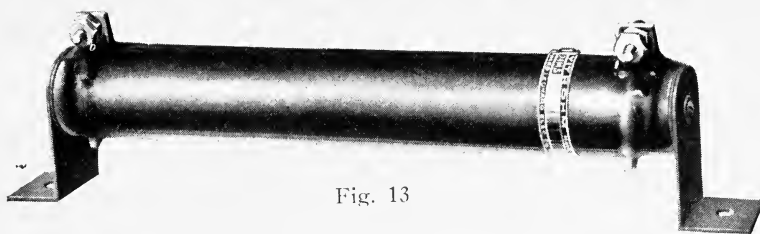

Fig. 13

metallic conductor could be operated as a resistor at a high temperature, thus reducing its bulk for any given dissipation. In many of these experiments there was the germ of the idea that was later to become the Vitrohm Resistor—a wire protected by a vitreous enamel, so that the wire could be used without exposure to air, which would cause it to oxidize.

Among these early experimenters was Albert T. Herrick, who tried, among other materials, plaster of paris and portland cement as the insulator-binder. He found, though, that the dissipation from the resistor was reduced, thereby changing its ability to dissipate heat. The silicates and sulphates from these substances combined with the wire at high temperatures, and eventually destroyed the resistance element.

Many substances were tried as electrical insulating and binding material in trying to prevent the chemical action of the air on the resistive material. But the success of these efforts was only partial, as spaces of dead air between wire and binder could not be eliminated and practically all substances seemed to enter into combination with the wire, as Herrick found. In addition to that, most of the materials were brittle and moisture-absorbing. They were also apt either to crack under high temperatures or to cause ruptures in the resistance wire, due to differences in expansion coefficients between the binding material and the wire.

HOW THE VITROHM RESISTOR IS CONSTRUCTED

Shortly following these experiments and endeavors of the last few years of the nineteenth century, the Ward Leonard Vitrohm Resistor, as it is known and used today, was developed. In the Vitrohm Resistor there is no dead air space which would prevent rapid dissipation of heat. There is no possibility of the wire destroyed by oxidation through contact with air or moisture; the protective coating of the Vitrohm is impervious to moisture. This coating is much like the enamel used on cooking utensils.

A Vitrohm resistor is made by winding a special resistance wire of low temperature coefficient of resistance upon a tube of refractory ma-

terial, and then coating the entire surface of the unit with a vitreous enamel. In this enamel lies one of the secrets of long life and permanent accuracy of the Vitrohm Resistor. In the firing process the enamel **entirely** surrounds the resistance wire. Heat, developed under load when the resistor is used, is instantly transmitted to the enamel, and from the enamel to the air. Heating and cooling do not affect either the wire or the enamel. Both expand and contract to the same degree.

The entire manufacturing process is one which places stresses on all of the component parts of the Vitrohm Resistor in excess of any normal operating condition. No resistor which is not perfect can last through the manufacturing ordeal of winding, coating and firing.

One of the outstanding advantages of the Vitrohm Resistor construction is that it permits the finest wire to be used without danger of depreciation or breakage. High resistance can, therefore, be built into small, easy-to-handle sizes suitable for compact radio sets. Further, you can run your Vitrohm Resistor right up to its rated capacity continuously without danger of altering its ohmic value or of burning it

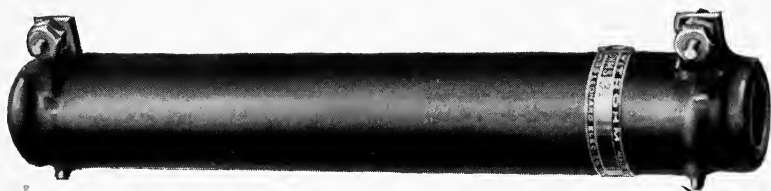

Fig. 14

out. The expansion due to temperature increases does not in any way affect the characteristics of the Vitrohm; enamel, wire and tube all expand and contract in perfect unison.

Ward Leonard Vitrohm Resistors have the advantage of proven permanence. They do not change in value.

Vitrohm Units are recognized by the leading electrical engineers who design large power houses and big electrical machinery as the standard of control for electrical circuits.

SIZES AND USES OF VITROHM RESISTORS

Be certain that you have the right size resistor unit for your purpose. In practically all radio hook-ups, the value of the resistor must be right, and it must carry a definite load (usually given in watts). The use of a resistor too small to carry the load is bound to result in overheating and to be a general source of trouble in your set. While many of the common uses and values of Vitrohm Resistors are listed, there are bound to be occasions when you will want special sizes or out-of-the-ordinary values of resistance.



Fig. 15

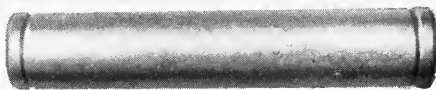

Fig. 16

HOW TO USE RESISTANCE

As we brought out in the forepart of this book, resistors are assuming a tremendous importance in radio development. How important they have become is best appreciated by those who have attempted to build any type of power supply unit using resistors constructed without basically sound engineering and manufacturing thought behind them. You have had resistances "guaranteed to dissipate 20 watts," which burned out under constant use at less than 5 watts. You have had resistances which were "guaranteed to be constant in value" which have altered 20 per cent, 30 per cent and even 50 per cent from their rated values in a few short weeks. Responsible manufacturers have not tried to fool you, but they have not had "Vitrohms" to offer.

WHAT A RESISTOR SHOULD BE

It seems almost unnecessary to say that a resistor should, first of all, be unchanging in value, regardless of temperature conditions or of the load imposed upon it. This characteristic in a resistor is dependent on the "temperature coefficient" of resistance. You want to know that when a resistor is placed in a circuit it will remain at that same value for all time. The Vitrohm Resistor has a practically zero temperature coefficient. Whether the resistor runs at half load, full load, or practically no load, its resistance value is assured. Remember that Vitrohms do not vary.

In purchasing a resistor, you should purchase permanent value. There is no economy in using resistors which will depreciate rapidly, affecting the value of radio apparatus which may represent an investment of two or three hundred dollars. The Vitrohm Resistor is built to last. Ten years from today any Vitrohm will give the same even, dependable service that it gave the day you purchased it.

The value of a resistor must be accurate. A resistor is a "gate" to control the flow of current. Not too much nor too little current should flow, but **exactly** what is required. Vitrohms are accurate. A Vitrohm resistor, too, given proper ventilation, will run indefinitely at its rated maximum load without depreciation.

Possibly you have wondered how the contacts are made between the resistance element and the terminal of a resistor. In most resistors this joint is exposed to the air. Oxidization and other depreciation of



Fig. 17
Resistor with
Fixed Taps.

the joint takes place, resulting in a noisy, high resistance contact. In the Vitrohm, this joint is clamped by a special process and then sealed for all time against attack of the air by the same coating of enamel which protects the wire. Care is taken in making this connection to have a maximum of the surface of the resistance wire in contact with the terminal, with the result that the resistance of the joint is practically zero. Thus, the value for the Vitrohm element is unchanged.

Resistors, particularly for radio work, should possess only one characteristic—that of resistance. There are many places in a radio circuit, notably in the radio frequency amplifier, where a unit possessing properties other than that of resistance will often alter the operation of a circuit. The most common faults which resistors have, other than those associated with resistive quality, are inductance and capacity. Capacity in this case refers to the property of holding or storing energy as does the ordinary fixed condenser.

Inductance in the Vitrohm Resistor is so low as to be difficult of measurement. At frequencies approximating those encountered in broadcast work, the inductance of a Vitrohm is considered less than that of a solenoid of the same dimensions and same number of turns of wire. This is due, primarily, to the fact that the resistance wire on a Vitrohm tube is so spaced that the inductance is consequently low.

In attempting to measure the distributed capacity of a Vitrohm Resistor, the same difficulty in measurement is encountered as with the inductance. The Massachusetts Institute of Technology, through Mr. F. S. Dellenbaugh, Jr., head of the Research Division, states in a report that the errors in the instruments used would be, in all likelihood, larger than the amount of capacity added to a test circuit by a Vitrohm Resistor.

Excerpts from this report are given herewith. To the man interested in resistors and their use, they will give information which will tell the whole story of Vitrohm Resistors and their superiority for all uses:

INDUCTANCE

It will be seen from this table that at 60 cycles the effect of the inductance is negligible. The column giving 0.1 degrees phase angle indicates that the third harmonic of 60 cycles might be affected slightly

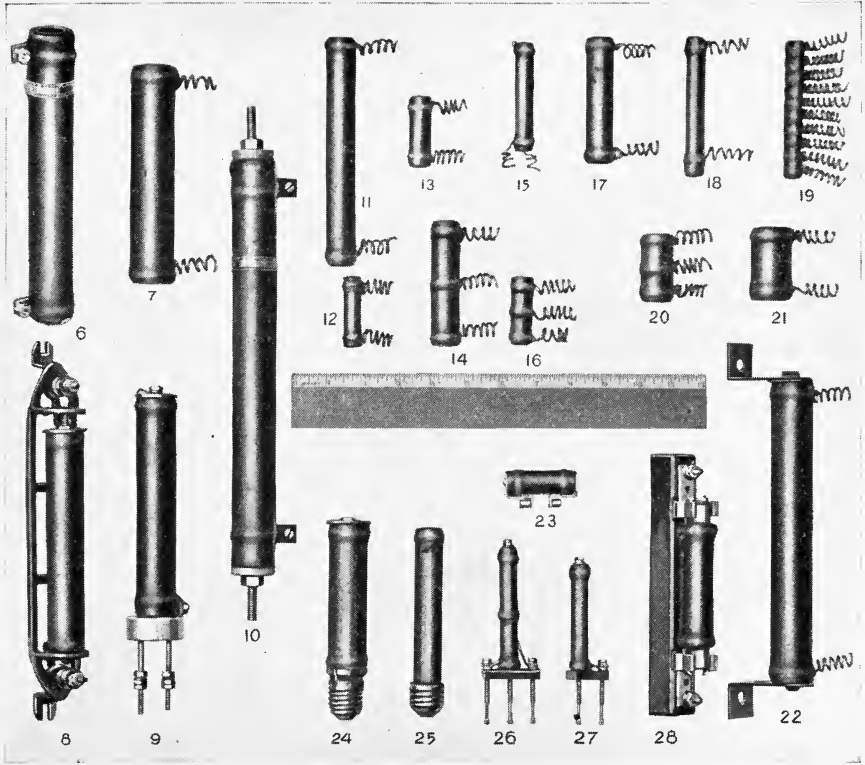

Fig. 18

by the inductance, but the power factor values, which are usually the determining element, are not affected noticeably until such high frequencies are reached that no commercial instruments of any kind would be accurate. It is therefore probably safe to say that the assumption, upon steady state A.C. tests, that the tubes are non-inductive, will introduce an error which is far less than that existing in a Weston high grade commercial A.C. meter such as the Model 370 shielded ammeters.

DISTRIBUTED CAPACITY

As already mentioned it is practically impossible to do anything theoretically with distributed capacity. A curve sheet is shown giving the results of the resonance tests for determining the values of distributed capacity as usually done in radio measurements. The two coils IC-6 and IC-7 are single layer coils of rather small number of turns about 4 inches diameter, wound with No. 19 d.c.c. wire, in the usual manner for radio inductances, and it will be seen that the

resistance tubes have less distributed capacity than coils of this type, so that it should not introduce any difficulties even with radio frequencies.

It might be possible to find injurious resonant effects due to the natural period of the coils upon the very high frequencies. The resistance is so high, however, compared to the inductance, that the damping is large and in many cases the critical resistance is exceeded and no resonance can be produced. The value of resistance in terms of inductance and capacity which will dissipate all the energy stored in the magnetic or electrostatic field within part of a cycle and so prevent any oscillatory discharge and hence prevent resonant effects is:

(15).	$R = \sqrt{4L/C}$		or	$C = 4L/R^2$	
Tube No.	Inductance $H \times 10^6$	Resistance Meas. D.C.		Value of C From (15).	
D-10	19.2	10.41	70° F.	0.705	MF.
D-20	43.7	20.68		0.407	"
D-50	78.7	51.15		0.120	"
D-100	71.0	102.10		0.027	"
D-500	105.5	253.3		1530.0	MMF (MF $\times 10^6$)
D-1000	182	1029		695.0	"
D-10,000	963	10,210		36.7	"
D-100,000	11,800	101,800		4.54	"

These figures show the capacity which could be used in connection with the given tube and still obtain resonance or oscillatory conditions. Any capacity less than those being will give oscillations, the frequency being determined by the usual formulae for discharge of energy in a circuit containing L, R and C. Any capacity greater than those given will produce a circuit combination in which natural oscillations cannot be produced. This capacity includes the effect of distributed capacity. Therefore if the value of capacity is less than the distributed capacity, the tube will be absolutely non-oscillatory under all conditions.

This condition is approached by the 10,000-ohm tube, the capacity probably being of the same order of magnitude and very close to the distributed capacity. Slight natural oscillations might be produced but they would be very rapidly dampened, and would cause no difficulty in any usual circuit conditions. The 100,000-ohm tube has a required capacity for resonant conditions of much less than the distributed capacity and therefore can never be oscillatory. As a matter of fact attempts to resonate both of these tubes at radio frequencies were absolutely unsuccessful.

OHM'S—Law

How to Use It in Solving Common Resistor Problems

Ohm's Law is a formula which is helpful in solving almost any problem which might come up in direct current work. As practically all radio eliminator work deals with direct current, a sound understanding of Ohm's Law will aid materially in understanding the reason for the use of a particular value of resistance in a particular point.

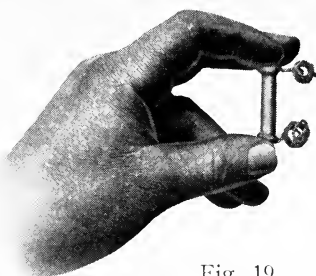

Fig. 19

The resistance of this "infant" Vitrohm is 15,000 ohms. The wire with which it is wound is only one-third the diameter of a human hair, but the unit has all of the sturdiness of its bigger brothers, though it is the size of a cigarette.

This law is concerned with the relation of three factors which are always present in an electrical circuit; the resistance, measured in ohms; the electrical pressure, which is measured in volts; and the current, which is measured in amperes. It is important to note that all of these factors are present in every electrical circuit. Figure 21 shows a simple circuit that will explain this more clearly:

In this circuit, the potential is 6 volts supplied by a battery, the resistor unit has a resistance of 10 ohms, a current of 0.6 amperes will flow through the circuit when the switch is closed.

$$I = \frac{E}{R} \quad I \text{ (Amp.)} = \frac{6}{10}$$

This simplified gives the result $I = 0.6$ amp.

The relation between these factors in an electrical circuit is expressed by Ohm's Law in any one of the following three methods:

$$E = I R$$

$$I = \frac{E}{R}$$

$$R = \frac{E}{I}$$

"E" = The electrical pressure in volts.

"I" = The current in amperes.

"R" = The resistance in ohms.

As you see, it is possible to find any one of the three factors in this formula when the other two are known.



Fig. 20

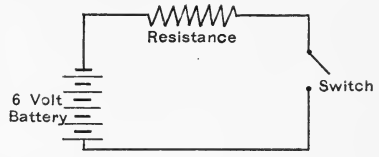

Fig. 21

The Vitrohm Resistor Kit belongs on every experimenter's work bench. The kit contains eight resistors of assorted values. Rated at 20 watts, they carry real loads, are sturdy, and easy to use.

One of the most common problems in the use of Vitrohm Resistors is to find the amount of current which the resistor will pass at a given voltage. Let us take, for example, the case where a resistance of 50 ohms is placed in a circuit with a potential 100 volts across it. To find the current which is flowing in this circuit, we choose the second formula,

$$I = \frac{E}{R}$$

and substitute for "E", 100, and for "R", 50. By solving the

equation, we find that the value of "I" is 2 amperes. Therefore, in selecting the Vitrohm to use in this circuit, we must take care that it is of sufficient capacity to carry the load.

It has probably been noticed that mention has frequently been made of the term "watts" as a measure of the carrying capacity of the Vitrohm Resistors. In the problem above, we found that a current of 2 amperes would flow through a resistor of 50 ohms which had a potential of 100 volts across it.

Still, we do not know what Vitrohm would be most satisfactory to us to carry this current. It is necessary to translate these factors into a measure of the current carrying capacity of the resistor. The units are rated in "watts," which is a measure of electrical power and is the product of volts times amperes. The Vitrohm Resistor chosen for the last problem should, then, have a continuous wattage dissipation of 200 times, 100 volts, 2 amperes, or 200 watts.

Ohm's Law comes into use again solving a problem in which the term "watts" is used. If either the volts or amperes are known in a cir-

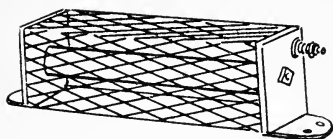

Fig. 22

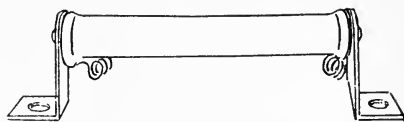

Fig. 24

Wire cages, which can be obtained for all of the Vitrohms, should be used where the resistor carries considerable current and dissipates a large amount of energy (gets hot).

Sizes of mounting brackets have been developed for all Vitrohms. A few sets of these clips will solve the problem of mounting the larger Vitrohms.

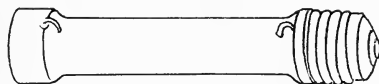

Fig. 23

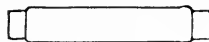

Fig. 25

Vitrohms with Edison Screw Bases are very handy units to have when frequent change of resistance values is necessary. Any type Vitrohm Resistor can be equipped with these bases.

This special mounting, which is similar to that used cartridge fuses, can be had for any type of Vitrohm.

cuit, the other may be found by dividing the number of watts by the known quantity. By the use of Ohm's Law, the resistance may be found. As a check on this, we will return to our problem: An ammeter shows a total of 200 watts being dissipated. The problem is to find the electrical pressure in volts and the resistance in ohms in the circuit.

By dividing the watts, 200, by the amperes, 2, we find that 100 volts is the required potential. Returning to Ohm's Law, by substituting 100 volts for "E" and 2 amperes for "I," we find that the resistor measures 50 ohms.

These few examples will serve to show how many of the problems which come up in resistor work may be easily solved by you and how they may be applied to your every-day radio work.

Some Popular Circuits Using Vitrome Resistors

In the following pages are given schematic circuits of a number of power supplies which will prove of interest to the experimenter. All employ standard apparatus which may be easily obtained. The direct current apparatus shown will be of special value to a large number of experimenters who have been heretofore neglected by those responsible for radio development.

As many of these circuits employ methods for obtaining C bias voltage for the grid circuits of power tubes, a review of this problem will be helpful.

The event of the power tube brought with it certain disadvantages in the way of voltage requirements. The 171 tube, for example, requires 180 volts on the plate and approximately 40 volts negative bias for the grid. Plate supply units nearly all supply the plate voltage, but in very few of them has provision been made to supply C voltage as well.

There are a number of decided advantages to be gained in obtaining the bias voltages from the same source as the plate voltage. Among these is the fact that changes in the eliminator output voltage, and consequently the voltage applied to the tube plates, will result in proportional changes in the C bias voltage. That is, if the plate voltage increases due to a line surge voltage will increase also. If a dry cell C battery is used, this change is, of course, impossible, and changes in tone and volume are bound to result.

The sketch on page 35 is a method of obtaining C bias voltages directly from your present eliminator. There is one point to keep in mind in using this method; that is, you take away from the total output for the plate supply of your eliminator the same amount of voltage you take for the bias voltage. If you take 12 volts for the grid bias of a 112 tube, you remove 12 volts from the plate of the tube, unless provision has been made to compensate for this loss, or unless there was previously a voltage supply in excess of that required for the plates.

The method of use in finding the values of the Vitrohm Resistors to use for obtaining the bias voltage is this: Find the total amount of current flowing in the negative B line of the eliminator. This is done by using a milliammeter of 50 milliamperes (0.050 amperes) flowing and wish to have a 9-volt tap and a 15-volt tap, we again make use of Ohm's Law. Substituting 9 volts (the first tap we need) for "E" and 0.050 amperes for "I," we find that the resistance needed is 180 ohms. We want, though, an additional tap at 15 volts and this, by the same method, is found to be 300 ohms. We will need, then, two resistances in series, one of 120 ohms for the 15-volt tap. This same method can be used to produce the required resistance for any bias voltage wanted, or any number of voltages taps, providing the current flowing in the circuit is known.

A RECEIVER AND CURRENT SUPPLY UNIT OPERATED FROM THE A. C. LINES

The circuit diagrams of this receiver and supply unit are shown in circuits 9 and 10, and are practically self-explanatory. The coils

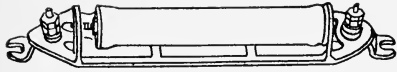

Fig. 26

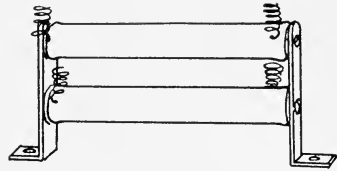

Fig. 27

Where a semi-permanent connection, as in laboratory work, is to be made, this special mounting is valuable.

Vitrohms mounted in this manner have the correct air space around each unit.

This mounting also makes a compact series or parallel connection possible.

Where 110-volt direct current is available, this unit eliminates both A and B batteries on any type of radio receiver. The circuit diagram is shown on page 16.

and condensers used may be of any standard make that will cover the wavelength band satisfactorily. As the condensers are ganged it is suggested that condensers having a capacity of .00035 mfd. (or more), be used.

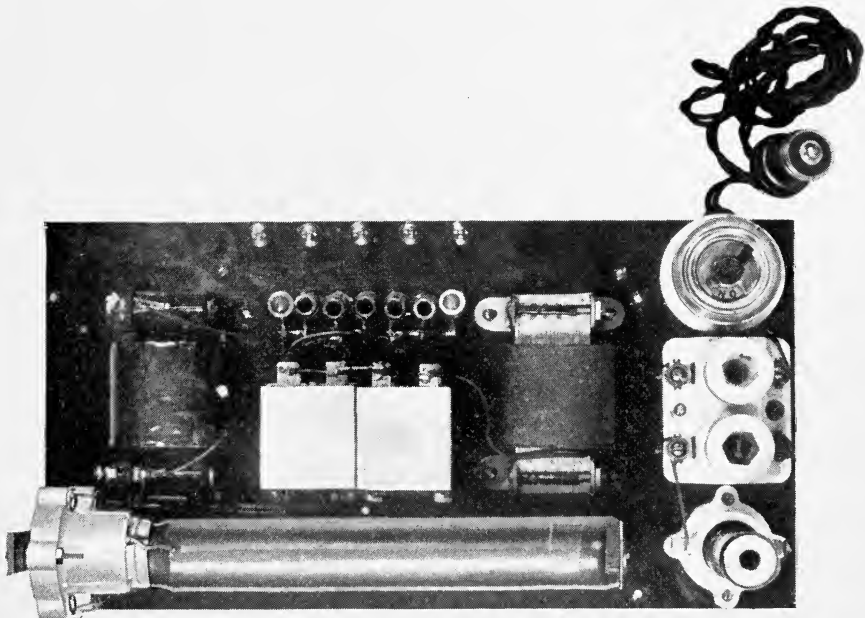

Fig. 28

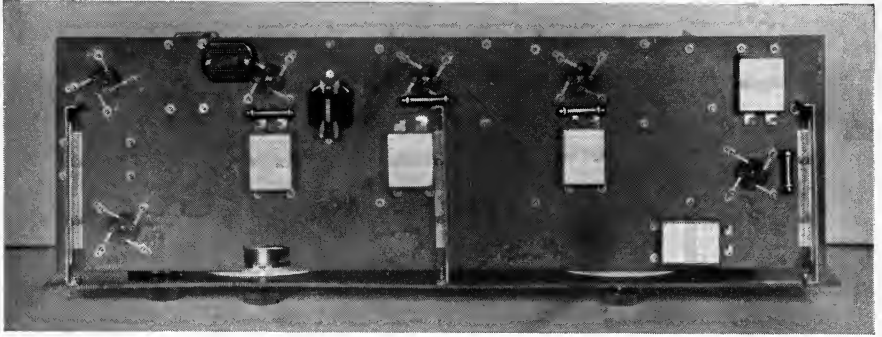

Fig. 29

This photograph of the sub-panel assembly of the A.C. operated receiver, figure 10, shows the placement of the filament shunt resistances and their size. Upon the accuracy of these Vitrohm Resistors depends the life of the 199 tubes.

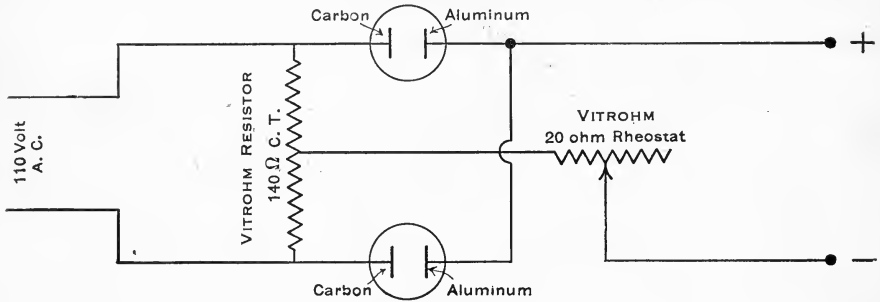

Fig. 30. Circuit 1

ALTERNATING CURRENT TRICKLE CHARGER

The "trickle" charger has met with the approval of many radio fans who find that it charges batteries with a minimum of trouble.

The charger shown above is for use on 110-volt alternating current lines and will charge the battery at a rate from 0.3 amperes to 0.6 amperes. The center-tapped shunt resistance of 140 ohms is a Ward Leonard Vitrohm. The rheostat is a 4-in. Vitrohm 20-ohm field rheostat.

The rectifying element is composed of carbon rods, $\frac{3}{8}$ in. in diameter and about 2 in. long. The aluminum electrodes may be of the same dimensions. The carbon and aluminum should be separated by about $\frac{1}{4}$ in. A simple method for getting contact on these elements is to drill and tap a 6-32 hole and then tightly screw in a long 6-32 stud which can be attached to a rubber strip running across the mouth of the jar. The electrolyte used is a saturate solution of ammonium phosphate which contains a small percentage of postassium phosphate. The cost of operating this trickle charger is low, and the only replacements necessary will be of the aluminum electrodes. This should be done about once every six months.

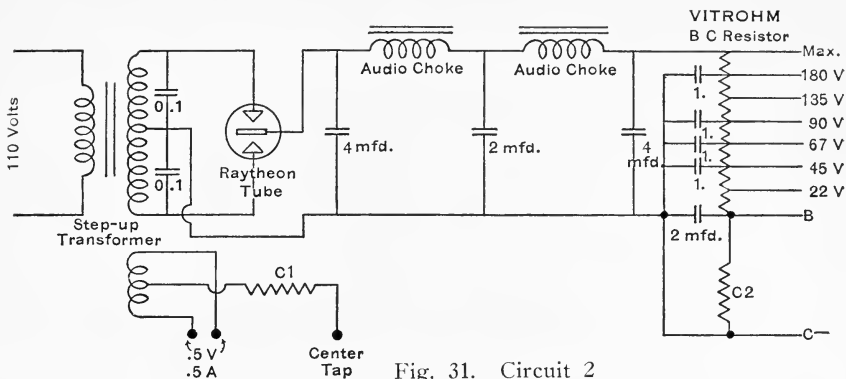

Fig. 31. Circuit 2

B AND C ELIMINATOR COMBINED WITH FILAMENT SUPPLY FOR THE POWER TUBE FOR USE ON ALTERNATING CURRENT

This eliminator will supply about 250 volts for the tube plates as well as C bias voltages for the radio and audio frequency tubes. All of the apparatus is standard. The step-up transformer should be capable of supplying 340 volts on each side of the center tap. The Raytheon Rectifier used is of the BH Type and will deliver up to 85 m. a. without any difficulty.

Resistance C1 has a value of 2250 ohms when used to produce the negative grid bias for a 171 type tube. C2 may be of any value to produce the required bias voltage. This tap is commonly used to supply the bias voltage of the radio frequency and first audio tubes.

The Ward Leonard BC Resistor 507-9 across the output of the unit gives almost all of the commonly needed voltage taps. Be sure that each tap used is by-passed by a condenser to the negative line. "Motorboating" and unbalance of the receiver circuits is likely to occur otherwise.

B & C SUPPLY UNIT FOR ALTERNATING CURRENT

The apparatus used in this eliminator is similar to that used in circuit No. 2 except that no provision is made to run the filament of the power tube from the alternating current. The method of obtaining the bias voltages was explained in detail on page 32.

A 110-VOLT DIRECT CURRENT A & B SUPPLY UNIT

Where 110-volt direct current is available, this eliminator can be used with perfect satisfaction to supply both the A and B current for a radio set using as many as 12 tubes of the 201A type.

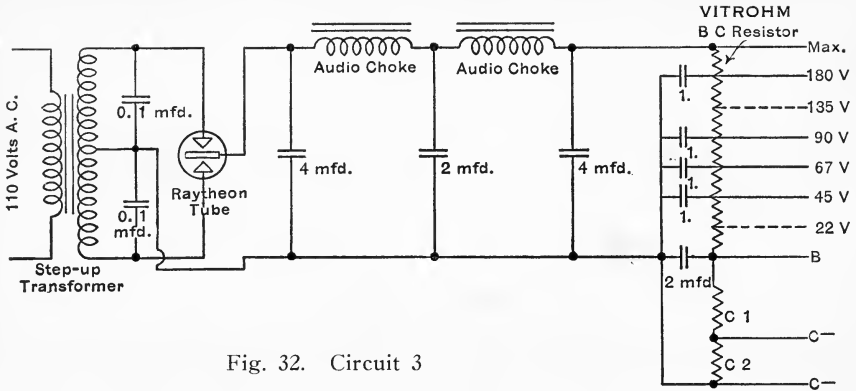

Fig. 32. Circuit 3

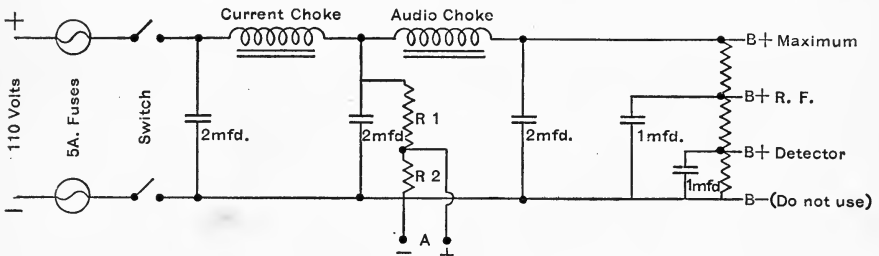

Fig. 33. Circuit 4

The current choke should be capable of carrying at least 3 amperes without any serious loss in voltage occurring across it. Resistances R1 and R2 are Ward Leonard Vitrohms which are varied to suit the particular receiver with which the unit is to be used. Either the Ward Leonard BC 507-9 Vitrohm Resistor or the Vitrohm Resistor Kit may be used to obtain the voltage taps needed.

To adapt the unit to your set, it is only necessary to figure the total amount of current in amperes which your set uses and then to choose the correct Vitrohms for R1 and R2.

The following precautions should be observed in operating your set from this eliminator:

1. Place a condenser of 0.5 mfd. capacity in the ground lead of the set.
2. Be sure that all of the tubes are in the set before the unit is turned on.

It is not possible to step-up direct current and, therefore, 100 volts is the maximum which may be obtained for the plate supply. If plate voltage in excess of this is required for the operation of power

tubes, connect a B battery in series with the positive post of the unit. This battery should be 45 volts to produce the necessary 157 volts for a 112 tube and 67 volts to produce the 180 volts for a 171 tube.

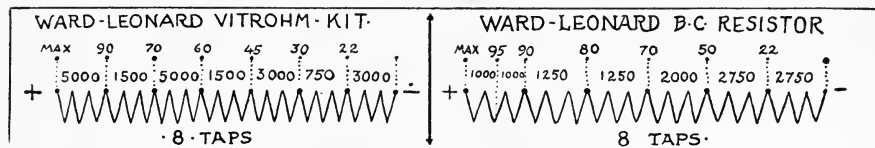

Fig. 34

Either the Vitrohm Resistor Kit, 507-47, or the Type BC Vitrohm tapped Resistor, 507-9, may be used to obtain the necessary plate voltages from the 110-volt direct current unit.

FILAMENT DRAIN AMPERES
(For Standard Tubes)

Amperes	R-1	R-2
.75	1 DEB-90	1 EB-12.5
1.	2 DEB-90	1 EB-5
1.25	2 DEB-90	1 EB-6
1.5	2 DEB-90	1 EB-7
1.75	2 DEB-90	1 EB-10
2.	3 DEB-90	1 EB-3.5
2.25	3 DEB-90	1 EB-4.25
2.5	3 DEB-90	1 EB-5
2.75	3 DEB-90	1 EB-6
3.	3 DEB-90	1 EB-7

The values for 199's are selected as follows: For current drains from 0.18 amperes (three 199's) to 0.36 amperes (six 199's or four 199's and one 120 power tube), use 1 DEB-90 as R-1 and 1 EB-3.5 as R-2.

For current drains from 0.42 amperes (seven 199's or five 199's and one 120) to 0.54 amperes (nine 199's or seven 199's and one 120), use 1 DEB-90 as R-1 and 1 EB-4.25 as R-2.

If more than 0.45 amperes is drawn by a set using 199's, the values for the resistances may be obtained from the regulae tables.

The table of 'B' voltages shown above gives almost all of the voltage combinations which will be needed to operate a set. While none of these values are absolute, they will be found accurate within a volt or so. If extra taps are required, be sure to by-pass each lead with a 0.5 mfd. condenser to the—A line.

A 32-VOLT DIRECT CURRENT FILAMENT SUPPLY UNIT

This unit will provide A current for sets using up to 12 tubes of the 201A type. Its operation is simple: it is used exactly as one would a storage battery. There are no special precautions to observe in the operation of this unit other than to place a condenser of about 0.5 mfd. in the ground lead of the receiver.

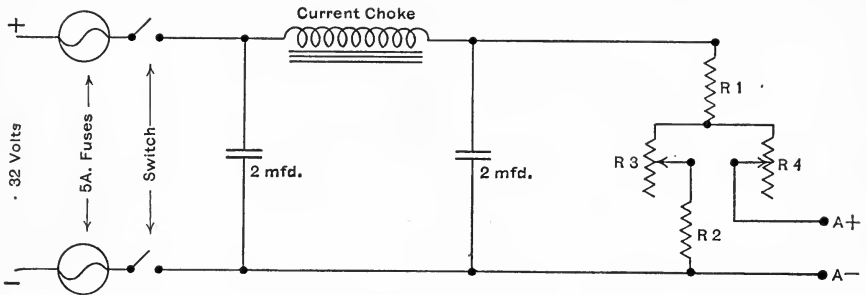

Fig. 35. Circuit 5

Resistance R-1 is a Vitrohm Resistor as is R-2. These are varied to fit the particular receiver which is to be operated with the unit.

The current carrying choke should be capable of carrying at least 3 amperes without an appreciable voltage drop.

FILAMENT DRAIN IN AMPERES

.75	EB-12.5	EB-5
1.	EB-12.5	EB-7
1.25	EB-10	EB-5
1.5	EB-10	EB-7
1.75	PEB-6.4	EB-3
2.	PEB-6.4	EB-3.5
2.25	PEB-6.4	EB-4.25
2.5	PEB-6.4	EB-5
2.75	PEB-6.4	EB-6
3.	PEB-6.4	EB-7

For sets using 199's, regardless of the number, use as R-1, 1 EB-45, and as R-2, 1 EB-7.

A PLATE SUPPLY UNIT FOR POWER AMPLIFIERS

The transformer used supplies approximately 525 volts output for the plate supply and should be equipped with two 7½-volt center tapped filament windings.

Rheostat R-5 should be variable from 0-100,000 ohms.

Rheostat R-6 is a 1750-ohm potentiometer, provided with an extra contact.

Resistor R-7 is a 1600-ohm Vitrohm Type ST-3, 507-7.

The balance of the material is standard. Be sure that the fixed condensers are capable of standing 500 volts d. c. continuously.

This is a true power supply unit supplying 400 volts for the plate

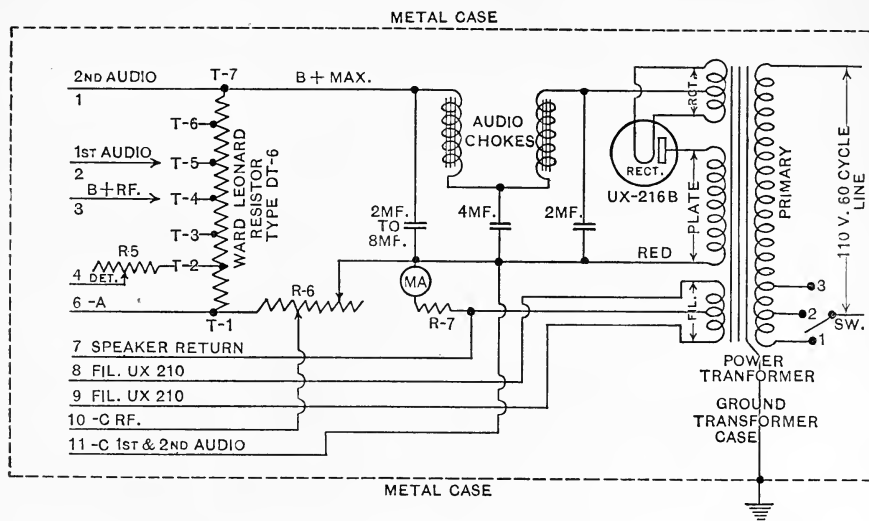

Fig. 36. Circuit 6

of a UX-210 tube, as well as plate current for the receiver. The milli-ammeter used should have a range of 0-100 m. a.

If a ground is used on your present receiver, do not ground any circuit other than that indicated in the diagram.

OBTAINING C BIAS VOLTAGES FROM YOUR PRESENT UNIT

Figure 37 shows a simple method for obtaining bias voltage from your present supply unit. It is only necessary to break the negative B line at the point indicated by the "X's" and to place a by-pass condenser across this point. The condenser should have a value of approximately 2 mfd.

The methods of figuring the values of the resistors R-1 and R-2 are given in the text on page 12.

Figure 38 gives a method of securing C bias voltage for a power tube that is operated from a center-tapped filament heating winding on the power transformer. Resistor R-1 will give the bias voltage for the first audio tube and the R.F. tubes. The method used in obtaining the value of this resistor is identical with that used for Sketch I.

Resistor R-2 has the following values of the various power tubes: UX-112÷507-32 Vitrohm having a resistance of 1000 ohms, for a 171 tube, a 2250-ohm unit, 507-16 is used. The UX-210 power tube uses the 507-17 Vitrohm, Type ST-3, having a resistance of 1600 ohms.

THE VITROHM KIT—TWO USEFUL COMBINATIONS

The Ward Leonard Vitrohm Kit consists of 8 Vitrohm Resistors of the following values: 1—750 ohms, 3—1500 ohms, 1—3000 ohms, 1—3500 ohms, and 2—5000 ohms.

Figures 39 and 40 show two of the possible combination for which these units may be used.

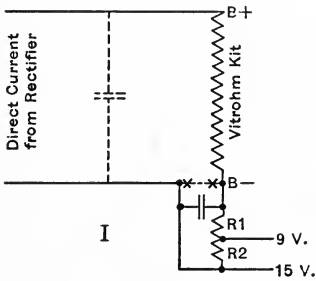

Fig. 37

Circuit 7

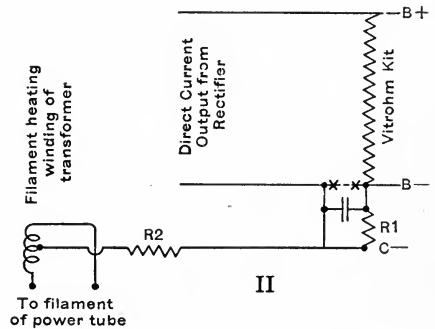

Fig. 38

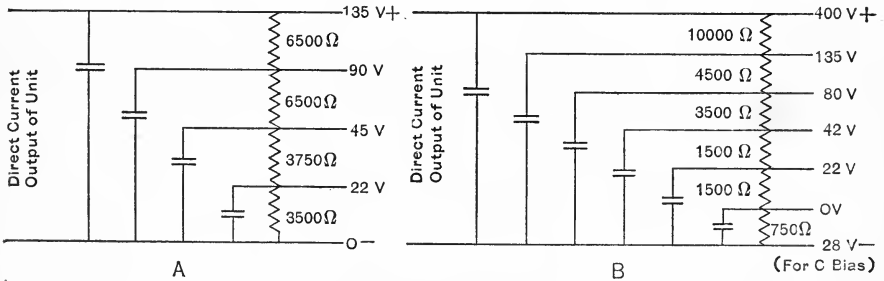

Fig. 39. Circuit 8

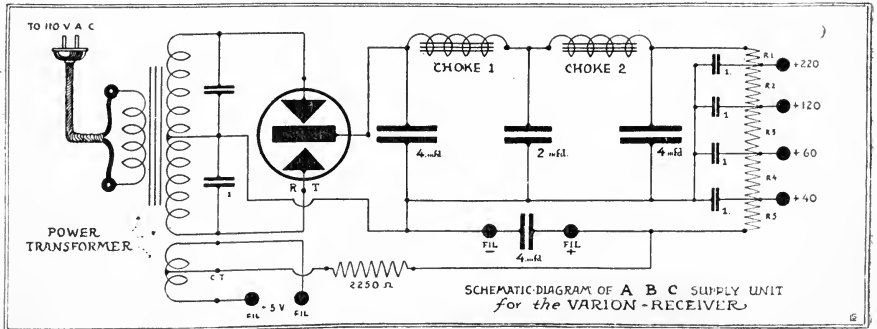

Fig. 40. Circuit 9

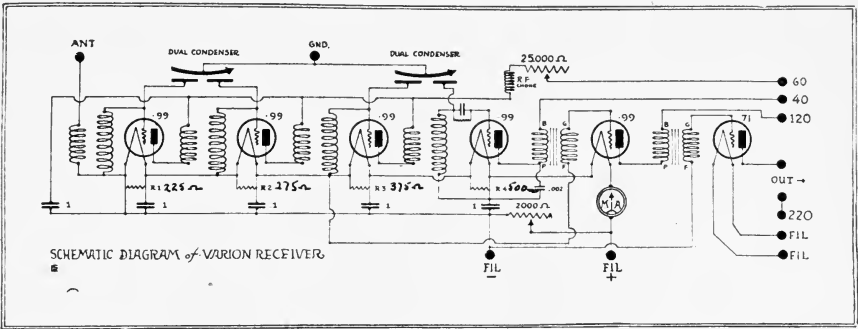

Fig. 41. Circuit 10

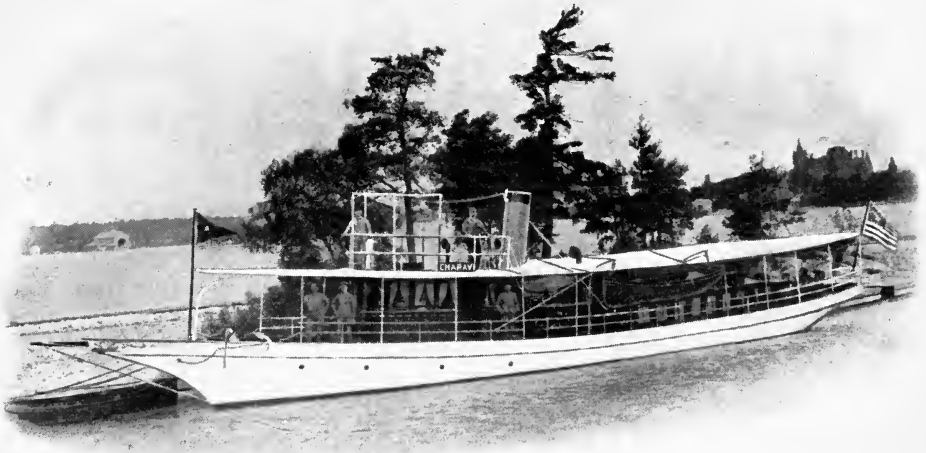

Fig. 41A.

RADIO FOR PLEASURE CRAFT.

A Yacht making a world cruise is the ideal location for a powerful broadcast receiver. With a radio receiver that will tune all wavelengths the yacht would be in communication with land at all times. Regardless of the distance from the United States the receiver would always be able to tune in KDKA on $63\frac{1}{2}$ meters as well as WGY, WLW and other short wave stations. As there are now broadcasting stations in practically all civilized countries of the world, the receiving log at the end of the cruise would probably total over 1,000 different broadcasting stations.



Fig. 42

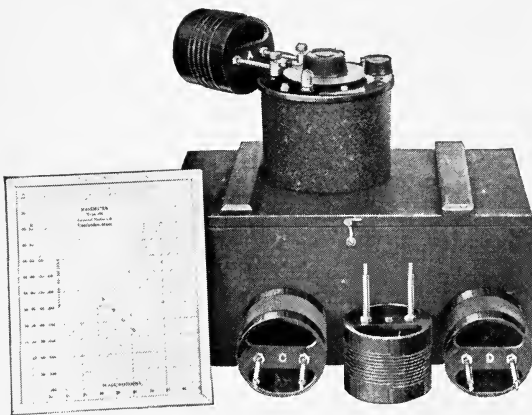

Fig. 43

Wavemeter for short waves. Note space wound solenoid coils, interchangeable to cover a wide wavelength range.



Fig. 44

Audio transformer with variable ratio for experimental work. Switch with taps at different turns provides varying ratios.



Fig. 45

Telephone transformer. Both primary and secondary windings have taps at different turns. Proper selection allows the input device to be properly matched to the output device.

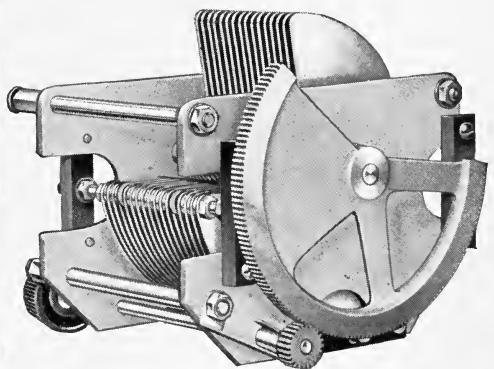

Fig. 46

High grade variable air condenser of fine electrical and mechanical design.

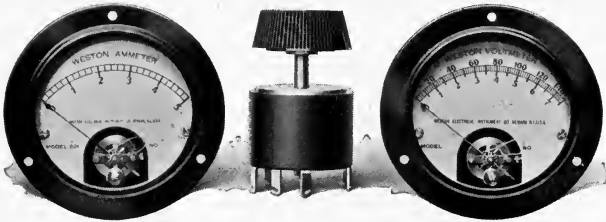

Fig. 47

Indicating meters for broadcast receivers. Milliammeter reads the total "B" drain. Voltmeter and switch reads the "A," "B" and "C" voltages, giving nine voltage readings in all.

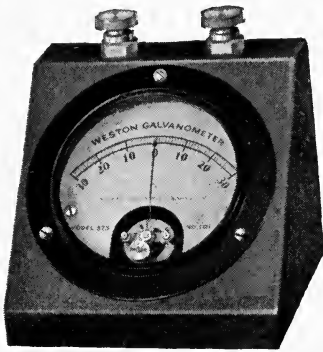

Fig. 48

Laboratory Galvanometer for reading very small D.C. currents.

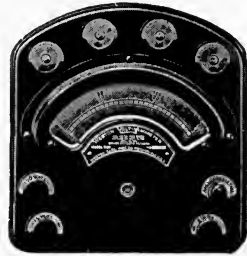

Fig. 49

Voltmeter with three scales to cover all "A," "B" and "C" voltages.

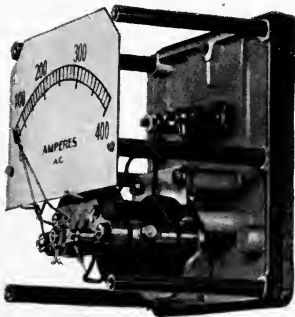

Fig. 50

Internal view of heavy duty ammeter which will measure up to 400 amperes.



Fig. 51

Thermo-ammeter to measure currents accurately at radio frequencies.

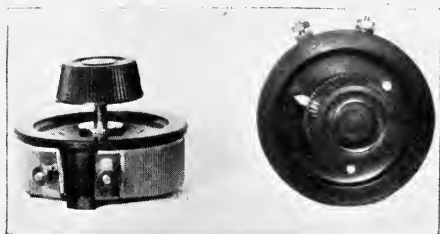

Fig. 52

Laboratory type heavy duty rheostat, a resistance variable by use of a sliding contact.

Fig. 54



Wave-trap to connect in antenna circuit to tune out near-by local station.



Fig. 53

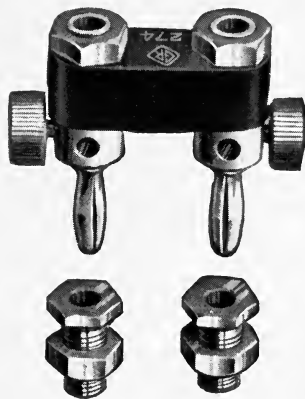

Fig. 55

Plug type jack.

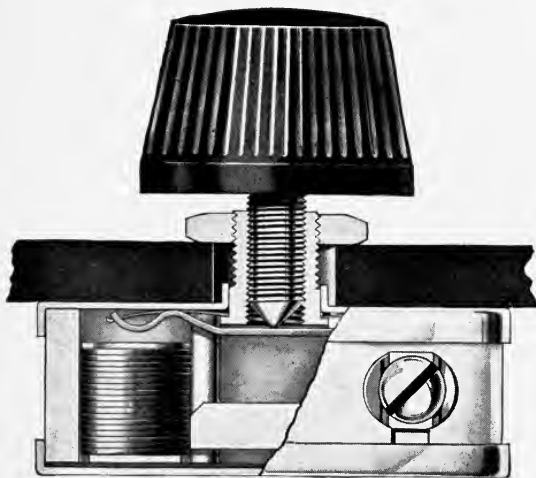

Fig. 56

Variable resistance of the compressed carbon black type.



Fig. 57

Amplifying transformer for intermediate radio frequencies

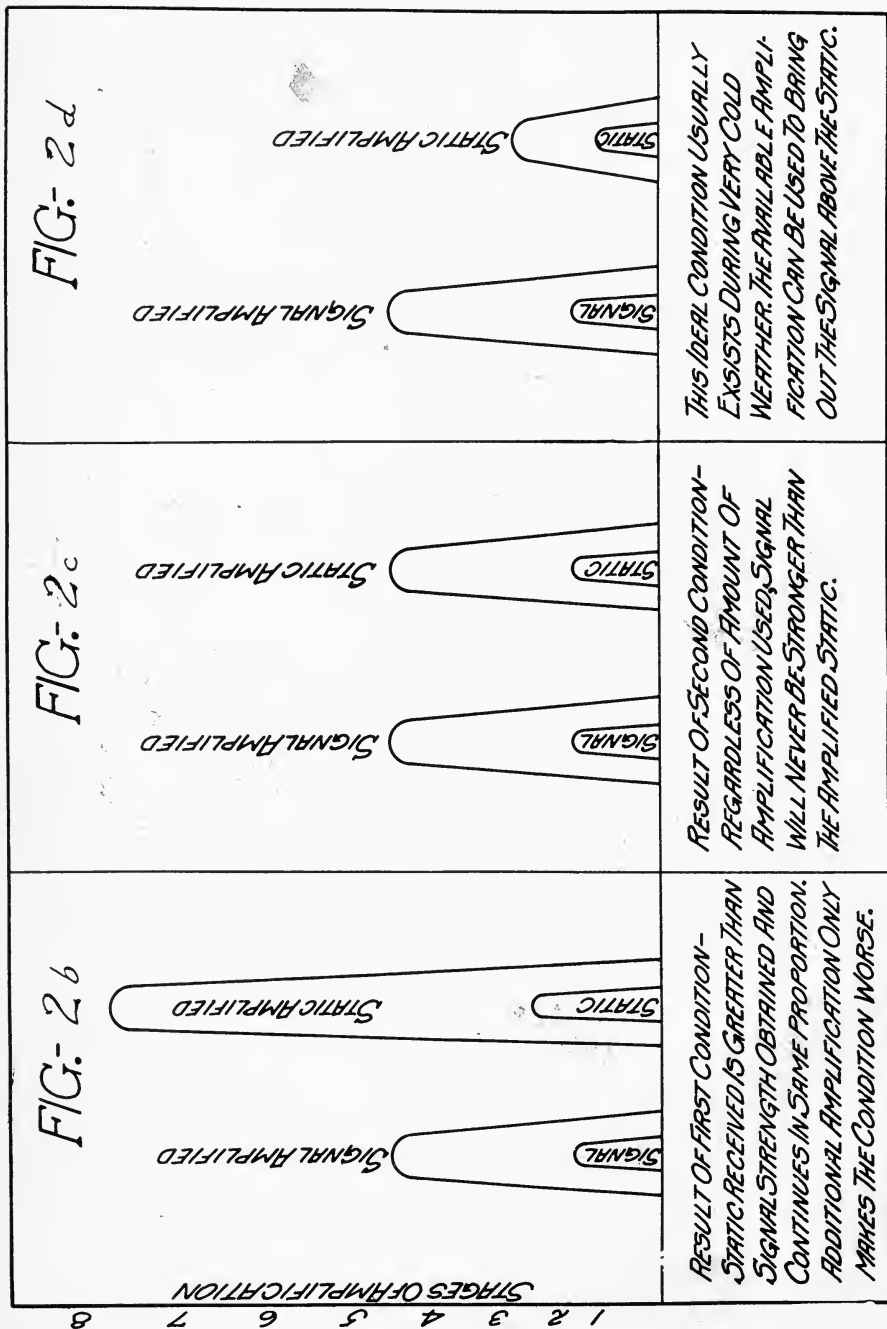
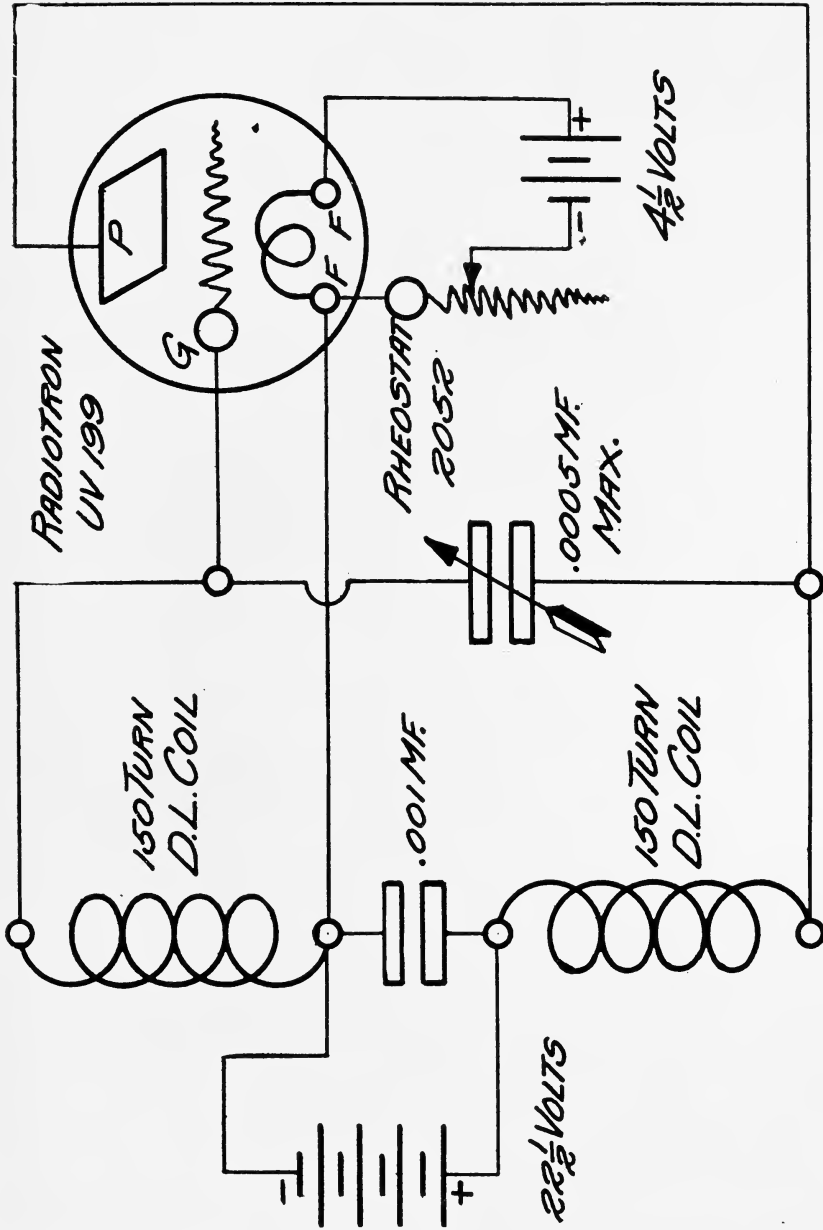

Fig. 58
Diagrammatic illustration of the Signal-Static Ratio.



SEPARATE OSCILLATOR FOR C.W. TELEGRAPH RECEPTION.
Fig. 59

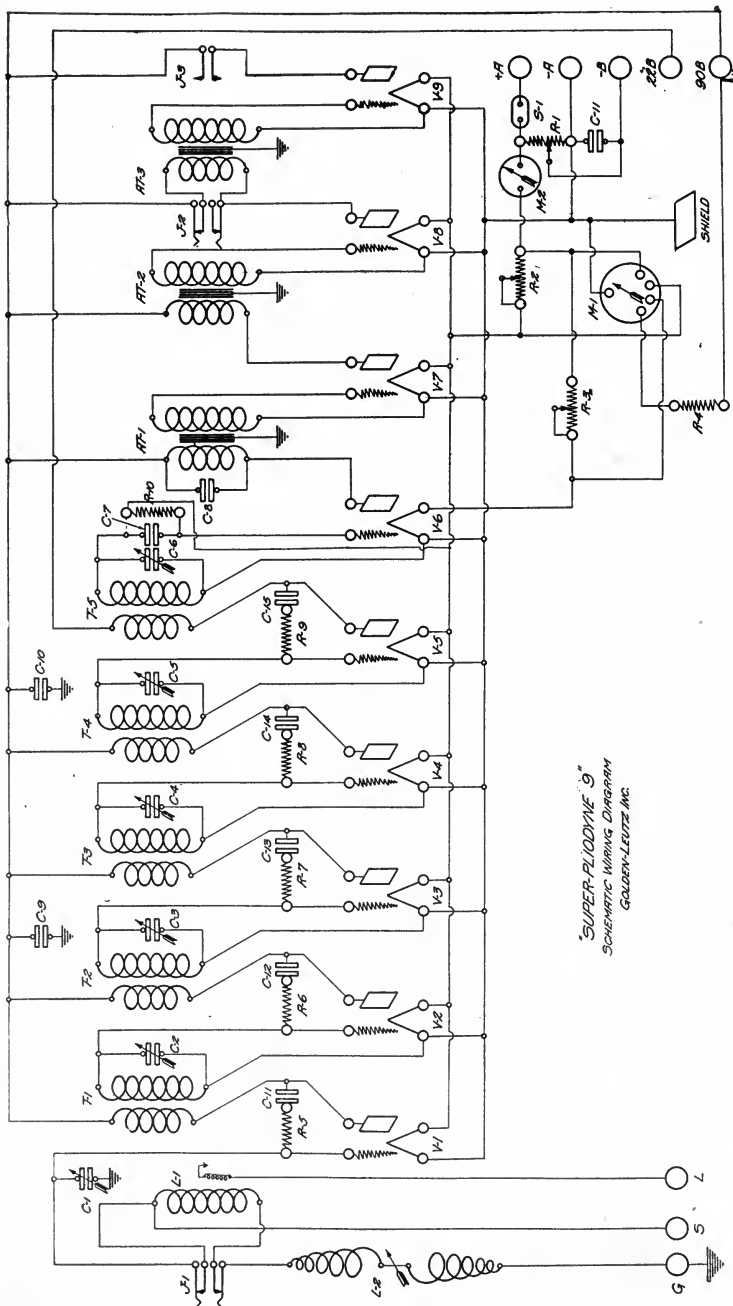

Fig. 60

Showing the Farrand System of tube neutralization, consisting of the resistors R-5 to R-9 (approx. 50,000 ohms) and condensers C-11 to C-15 (approx. .00005 M.F.)

Chapter II

RADIO LABORATORY APPARATUS

The Radio Receiver requires certain maintenance tools, just the same as any other piece of machinery. The two most important instruments to keep check on the receiver, are the Battery Hydrometer and Battery Voltmeter. The Hydrometer reading gives a fair check on the condition of the battery, a reading of 1250 to 1300 indicating "fully charged" and a reading of around 1100 gives a warning that the battery is nearly discharged. With the Storage Battery connected to the receiver and the tubes turned on (full load) the battery should show a reading of not less than 6 volts at the battery terminals. The condition of a dry B battery is determined by the voltmeter alone. A regular 45 volt B battery giving a reading of less than 30 volts is practically unfit for use. The reading of the dry B batteries should be made under load, that is when the receiver is in operation and the batteries are feeding the plate circuits of the receiver.

An ordinary direct current voltmeter, connected in series with a small battery is also useful in checking the continuity of circuits, transformer windings, resistors, etc., and to locate short circuits, grounds and improper connections. The above two instruments are the two most common used and their operation relatively simple. More advanced laboratory apparatus which is used in the development of advanced receivers and to conduct experimental radio reception will be described in the following paragraphs.

AUDIBILITY METER

In order to record the strength of signals received from different stations on different dates, a method must be used to determine the exact signal strength or audibility. The strength of distant signals varies continually during the day and night and also from day to day. An Audibility Meter is used to give the exact relative signal strength.

If a telephone receiver or loud speaker in which signals are being received is shunted by a variable resistance until the signals are just audible, the ratio of the current in the telephone or loud speaker to the current in the shunt is an indication of the strength of the signal. For instance, if the signal is just audible when 99% of the detector current flows through the shunt and 1% through the telephone receivers, the signal is said to have an audibility of 100. If S is the impedance of the shunt and T the impedance of the telephone receivers, the audibility constant is given by the equation:

$$K = \frac{S+T}{S}$$

For use in connection with an oscillating detector circuit, a simple series resistance is not sufficient to give an accurate reading. This is because the oscillating circuits are affected by changes in their constants very slight changes often causing variations of the telephone current quite out of proportion to the changes introduced. A series resistance must be added in the plate circuit to compensate for the reduction in resistance of that circuit caused by the shunting of the telephone receivers. In the Type 164 Audibility Meter illustrated it will be noted that the adjustable arm controlling the resistance, has two sets of contacts, one shunting the resistance around the phones and the other connecting the resistance (compensating) in series with the plate circuit. This meter keeps the impedance of the oscillating circuit practically constant when used at 1000 cycles. It is adapted for use with any telephones or speaker having a resistance of 2000 ohms. There are 32 steps giving audibilities of 1 to 2000. The first step has no resistance, so the meter may be left permanently connected in circuit if desired.



Fig. 61
Audibility meter.

DIRECT READING CAPACITY METER

When an accuracy of $\frac{1}{2}\%$ is permissible, a direct reading capacity meter is a great time saver in measuring the capacity of fixed and variable condensers. The Type 240 Capacity Meter will read any capacity from .001 to 10 microfarads.

The instrument consists of a capacity bridge with variable resistances in the ratio arms and capacitances in the unknown and standard arms. A schematic diagram of the circuit is shown. The input to operate the bridge is obtained from a small microphone buzzer operated by a $4\frac{1}{2}$ volt C battery. The resistances M and N are wound on thin bakelite strips to reduce the distributed capacity and inductance. R is a rheostat of 120 ohms.

The standard condenser C, is built up of heavy brass plates interspaced with mica dielectric, assembled under pressure and impregnated with paraffin. It is firmly clamped in a heavy aluminum frame so that its value will not change. To measure the capacity of a condenser, the condenser is connected to the two clips marker X. The Buzzer switch is turned on and the operator listens in the head phones. A loud buzz is heard and by adjusting the three dial switches and the power factor dial, the buzz is reduced to inaudibility. The reading of the three dials

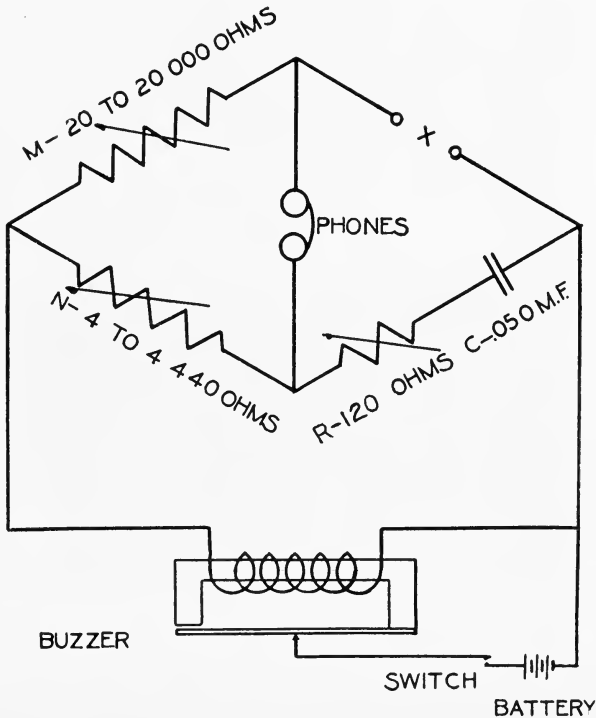

Fig. 62



Fig. 63
Direct Reading
Capacity
Bridge.

times the multiplier is the capacity in microfarads. The per cent. Power Factor is read from the Power Factor Dial. A high power factor indicates a condenser with high losses. For example a circuit may call for a .002 MF condenser and upon measuring three .002 MF condensers it may be found that each condenser is exactly .002 MF but one condenser make has practically no loss while the other two condensers of inferior design while having the proper capacity they also have excessive losses as indicated by the high power factor. This point is very important in variable condensers used in radio frequency amplifiers of the tuned type, high loss variable condensers will contribute to making the receiver broad in tuning, and also absorbing part of the signal received.

AUDIO OSCILLATOR

Most bridge measurements require a dependable source of alternating current of low power, and constant frequency. The Type 213 Oscillator meets these requirements and is also a rugged and reliable instrument.

The output of this oscillator is .06 watt at 1000 cycles. External binding posts are provided to give three different output values as follows: Low (.5 volt 100 milliamperes), Medium 1.5 volts at 40 milliamperes, High (5 volts at 12 milliamperes).

For some capacitance measurements it is desirable to use a high voltage. This increased voltage may be obtained by connecting an inductance and capacitance in series across the high voltage output terminals of the oscillator. By adjusting this circuit to resonance, volt-

ages as high as 50 or 100 may be obtained by connecting the output leads across the condenser. The instrument works from an A battery of four to eight volts. When running the oscillator may be heard for a distance of 25 feet or may be made silent by enclosing in a sound-proof box, a thin wooden box lined with felt or cotton.

The circuit used is shown in the diagram. The closing of the switch places the field magnetizing coil directly across the battery. Also across the battery is the primary of the input transformer in series with the microphone button. The resonance circuit consists of the secondary of the input transformer, the primary of the output transformer, the armature coil and the condenser. The output transformer secondary has three taps to permit obtaining the three different output



500 Cycle
Audio
Oscillator
with
Microphone
Button.

Fig. 64

voltages previously mentioned. The two transformers are used so that the direct current component is entirely eliminated from the output wave. Each transformer core has a small air gap to prevent distortion of the wave form. Since, however, the magnetic circuits are all nearly closed iron paths, there is very little outside field. This feature is very important where the oscillator is used close to the bridge. The tuning fork insures that the frequency be kept constant and at 1000 cycles. The resonance circuit is carefully adjusted to this frequency. Since the oscillator is self-starting, it may be located at a point distant to the bridge and controlled from a switch at the bridge.

By the use of the field magnetizing coil on one tine of the vibrating fork, instead of relying on its permanent magnetism, the polarity and intensity of the magnetization of the fork with respect to the armature are permanently maintained.

Success or failure in the operation of a hummer or audio oscillator, lies very largely in the microphone button. If the button heats so that the oscillator cannot be run indefinitely, if the adjustment of the button is not permanent, or if slight mechanical shocks change its operating characteristics, the oscillator has little commercial value. A distortion of as small an amount as one five hundredths of an inch from normal position of the mica will destroy the perfect operation of the button. In order that the button may be insensitive to mechanical shocks and yet operate properly at 1000 cycles, use is made of its high inertia at the latter frequency. One side of the button is attached to the tuning fork by means of a short flat spring. The other side, which has a projecting mounting point, is held in position by a specially designed self-centering spring. This combination of springs enables the button to withstand severe shocks, yet it has sufficient inertia so that perfect operation is obtained. The adjustment of the button is perfect and needs no adjustment after leaving the factory. This type of adjustment, together with the fact that the electrical constants have been adjusted to their optimum values, insures the continuous operation of the oscillator without heating. This oscillator is adapted for the usual alternating current measurements of inductance and capacitance. When ever a pure waveform is required, the oscillator should not be overloaded, as the wave form is dependent upon the load.

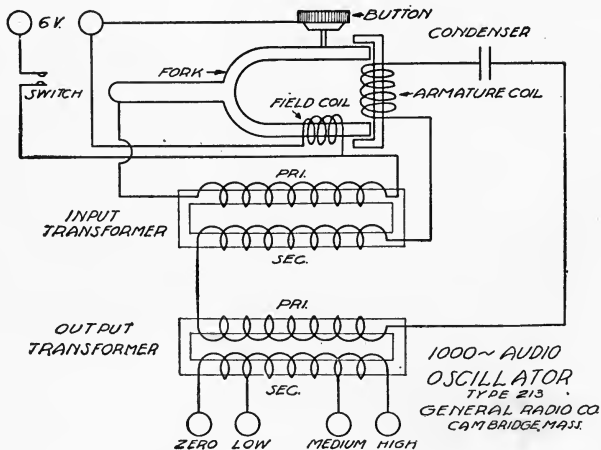

Fig. 65

OHMMETER

There are many occasions in laboratories, service stations, and factories where an approximate measurement of resistance is required. The Type 287 Ohmmeter is designed for a quick determination of resistance where an approximate value is sufficient. The Ohmmeter consists of a battery and meter in series with a resistance which protects the meter from damage at short circuit and also provides a zero adjustment. The dial is calibrated directly in ohms. Clip leads are provided for convenience in attaching the instrument to the circuits being tested.

One of the greatest uses of this instrument is the checking of apparatus and tracing of circuits. Its indication of the actual resistance of the circuit makes the Ohmmeter useful where the battery and telephone method of tracing circuits is of little use. This feature makes it possible to detect, not only open and short circuits, but also wrong connections, since the resistance between two points will indicate the instruments in circuit. Its operation is very simple, the two leads are placed on the unit to be measured and the resistance is directly indicated on the meter scale.

LOW FREQUENCY OSCILLATOR

Many forms of electrical and physical research problems require a source of alternating current of good wave form and variable over a wide range of frequencies. The properties of the oscillating vacuum



Fig. 66

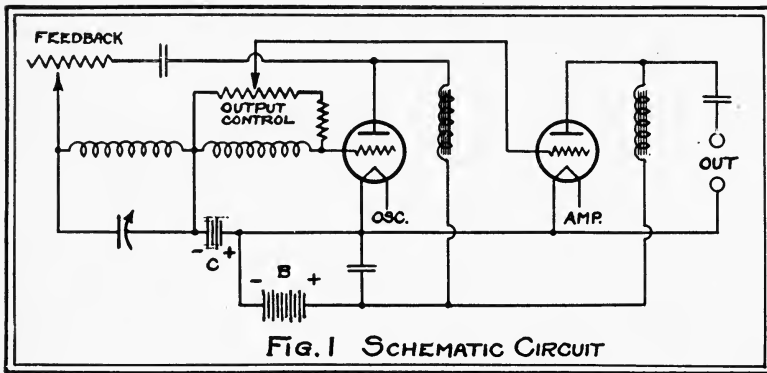

Fig. 67

Fig.
68

makes it inherently adapted for use as such a source. The type 377 Vacuum Tube Oscillator has a frequency range of from 60 to 75,000 cycles, extending through the audio and carrier frequency range into the lower radio frequencies. The simplified circuit of the oscillator is shown schematically. The frequency of the oscillating tube (left) is controlled by tuning the plate circuit. The output of the oscillating tube is fed through a coupling potentiometer to the amplifier tube (right). The plate of the amplifier tube connects direct to the output terminals. The parallel feed system of plate supply is used on both tubes.

A front view of the Oscillator complete is also shown. Two meters are provided and arranged with switches so that the filament and plate voltages or plate current of either tube may be read. The output of the oscillator is adjustable and may be held constant over the frequency range by means of the coupling potentiometer to the amplifier tube. The resistance marked feedback is in the plate of the oscillator tube and controls oscillation. For most satisfactory wave form the feedback control should be set at a point at which the tube just starts to oscillate.

The frequency is continuously variable by means of the seven controls on the lower half of the panel. There are three coils so tapped to give six switch positions, and a decade capacity system extending from .001 MF to 10 MF. An air condenser with maximum of .0011 MF makes the capacity system continuously variable. The oscillator is intended for use with either a UV201A, 112 or 210, for average use the UV112 is found satisfactory.

The wave form of the oscillator output is very closely sinusoidal. The largest single harmonic component in the voltage wave is of the order of 2%. Where particularly good wave form is required it is advisable to use tubes of the UX210 type. Load does not effect wave

form unless the amplifier tube is overloaded. The load will not affect the frequency, as it is not applied directly to the oscillating tube. Frequency does not vary more than one per cent under ordinary variations in tube conditions.

The power output of the instrument will vary with the plate voltage and the type of tube. With a UX210, the output is about .2 watt with 120 volts on the plate and .5 watt with 220 volts on the plate.

BEAT—FREQUENCY OSCILLATOR

In measuring loud speakers and audio frequency systems, it is often desirable to move through the entire frequency range quickly. The conventional type of vacuum tube oscillator, although it may be

Fig. 69

Beat
Frequency
Oscillator.

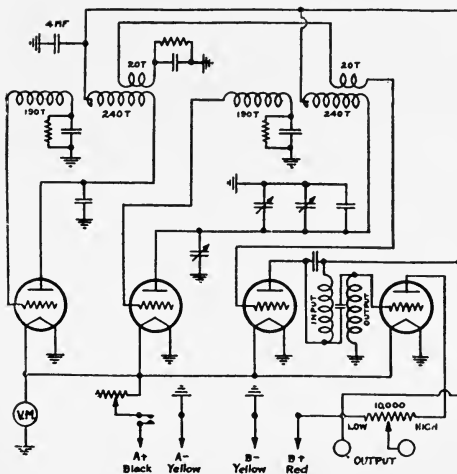

Fig. 70

Schematic
Circuit Diagram of the
Beat Frequency
Oscillator.

so designed to be continuously variable, requires the adjustment of a number of controls in varying the frequency through the entire audio range. As the change in frequency involved is large, about five hundred to one, it cannot be obtained by the rotation of any single instrument of practical construction. If, however, the measuring frequency is obtained by beating two oscillators together, a small percentage change in frequency of one of the oscillators will cause a relatively large change in the beat frequency. The type 413 Beat-Frequency Oscillator has an approximate range of 20 to 9000 cycles. The instrument consists of two oscillator tubes, a detector and an amplifier tube. The frequency of one of the oscillators is fixed at about 60 kilocycles, while that of the other is variable from approximately 50 kilocycles to 60 kilocycles. Both oscillators are coupled to the grid circuit of the detector tube. The oscillators are so constructed and shielded as to maintain a constant frequency over long periods without adjustment. The system of coupling the oscillators to the detector, supplying it with a low voltage from each oscillator is such that tendency of the two oscillators to, pull into synchronism as zero beat is approached is eliminated. The detector output is fed through a type 373 Double Impedance Coupler giving nearly constant amplification over the wide range of frequencies used, to an amplifier tube. The output of the oscillator is taken off across a 10,000 ohm resistor used as a voltage divider, permitting the adjustment of the output voltage without changes in the oscillator circuit proper which might affect waveform or frequency.

In the schematic diagram of this instrument will be noted three variable capacities. One is a small compensating condenser mounted inside the instrument. The purpose of this condenser is to correct for any slight inaccuracy in the fixed condenser in this circuit. Slight changes in frequency of either oscillator due to changes in circuit conditions may be compensated for by means of this condenser, which is adjusted to bring the two oscillators to zero beat. The frequency is changed by means of two other variable condensers, the main tuning unit of 500 MMF maximum capacity and a micro-condenser shunted across it for fine adjustment.

Either dry cell or storage battery tubes can be used and the plate voltage required is only $67\frac{1}{2}$. A voltmeter is provided to enable adjusting the tube filaments to their rated value. The oscillator has an output of approximately $2\frac{1}{2}$ volts. The variation in output voltage over the frequency range is about 10%. The wave form is satisfactory for most purposes, the total harmonics being at a maximum but 4% of the wave in voltage. This oscillator is particularly useful in the study of loud

speaker response curves, as the complete frequency range at practically constant intensity is available by one half revolution of the main dial so that peaks or hollows in the response of the speaker are immediately evident. Any tendency to blast at particular frequencies is quickly revealed. The 413 Beat-Frequency Oscillator may be used to modulate the output of the type 384 Radio Frequency Oscillator. The modulated radio frequency output thus obtained may be used in testing receiving sets for both radio and audio frequency response. The audio modulating frequency can be quickly compared with the audio frequency output of the receiver with an oscillograph such as the Type 338 described in this chapter.

RADIO FREQUENCY OSCILLATOR

A small radio frequency oscillator has a wide range of usefulness in the laboratory. For maximum utility such an instrument must have a wide frequency range and be readily portable. The type 384 Oscillator is of the plug in coil type. The range may be extended from 15 to 30,000 meters by means of 9 coils. A single UX199 tube is used which permits an entirely self contained instrument. A plate milliammeter is provided to indicate oscillations.

This oscillator may be used as a source in high frequency measurements of coils and condensers, or for the checking of receivers. It is particularly useful for the latter purpose when combined with the type 384 Beat-Frequency Oscillator. The oscillator is provided with input terminals so that the beat oscillator may be used as a modulator. In this manner the over-all receiver characteristics may be readily checked, both radio frequency and audio frequency tests being made simultaneously. This oscillator is also readily adapted to use as the auxiliary oscillator in conjunction with the type 275 Piezo Oscillator describes when using harmonics of the plate frequency for calibration of frequency standards.



Fig. 71
Portable
Oscillator.

AMPLIFIER TEST SET

The widespread interest in audio amplifier characteristics makes the development of a standard and reliable method of taking them highly desirable. The test method should reproduce as nearly as possible the working conditions of the amplifier. It should neither omit any factor tending to affect the characteristic, nor introduce any affects not present in the amplifier.

The coupling device of the audio amplifier is always used in the plate circuit of a vacuum tube whose impedance affects the action of the amplifier very greatly. It is therefore necessary that the test instrument either be so arranged that the coupling device is connected in the plate circuit of a vacuum tube, or that the effect of the plate impedance be reproduced in some manner. It is also important that no current be allowed to flow in the transformer secondary, as even a very slight secondary current will entirely alter the characteristic.

In the Type 355 Test Set all the necessary elements of a reliable test set are assembled in a compact unit. All changes in connections are made with quick throw switches. The cabinet also contains the vacuum tube voltmeter and its plate and grid batteries. The circuit used is shown in the schematic diagram and was selected after an examination of the test methods used in a number of leading laboratories. A resistance (R_p in the diagram) is used to simulate the impedance in series with the transformer primary. This resistance is variable in 5000 ohm steps and covers the usual range of tube impedences. A vacuum tube voltmeter is used as a measuring device. The constants of the voltmeter are so adjusted that the grid of the voltmeter tube cannot take current while the galvanometer is on scale.

The input voltage to the transformer under test is taken off across a portion of the high resistance across which the oscillator output is



Fig. 72
Amplifier
Test
Set.

impressed. The remainder of this resistance is used for checking the secondary voltage of the transformer. The voltmeter is used only as a transfer instrument. In order that the effect of the winding capacitances may be reproduced correctly it is desirable that the F minus terminals are connected together, both will be at ground A. C. potential, as under working conditions.

The vacuum tube voltmeter is also used to check input voltage, a transfer switch being provided.

The method of test is as follows: The input voltage is adjusted to the desired value by adjusting the oscillator output. The voltmeter is transferred to the transformer secondary, and the deflection of the galvanometer observed. If the transformer secondary voltage is high enough to send the galvanometer off scale, an additional adjustable bias is switched in and the meter needle brought on scale. The volt-

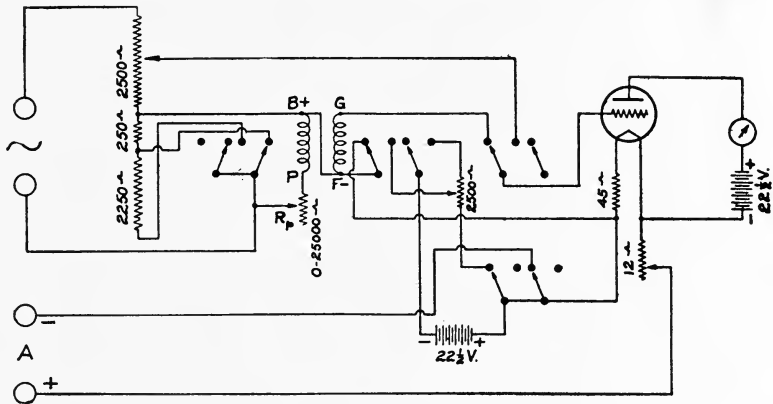

Fig. 73
Wiring Amplifier Test Set.

meter is again switched to the oscillator output, and the potentiometer adjusted until the reading is repeated. The voltage amplification of the transformer is then indicated on the scale attached to the potentiometer. When impedances or other coupling devices whose ratio is less than unity, are being checked, the multiplier resistance R3 is connected in circuit. Amplification factors as high as 1:10 are measurable with this instrument.

If it is desired to measure the effect of direct current saturation in the transformer primary, a battery and meter may be connected externally, in series with the transformer. If this is done, the battery should be disconnected when checking the input voltage. Impedance coupling units are connected as shown in the Fig. 76 supplementing the schematic diagram.

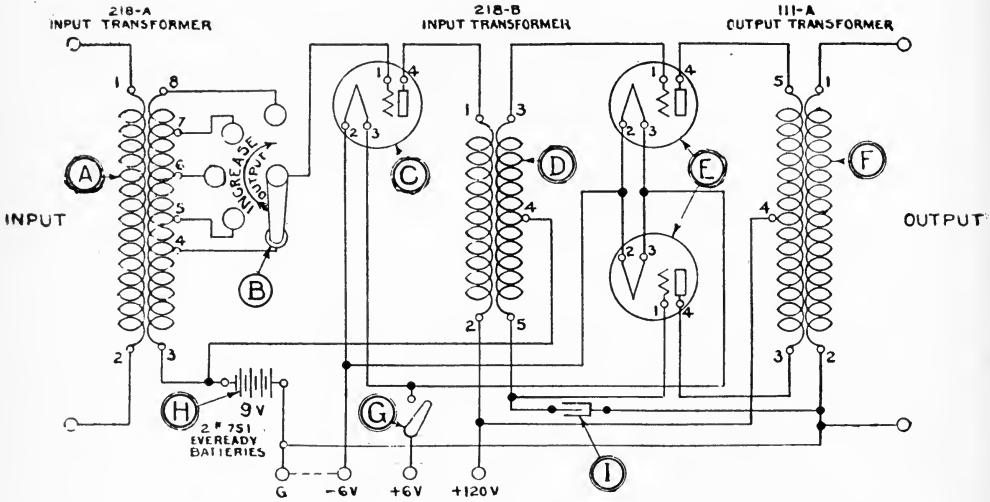

Fig. 74

Fundamental Circuit of the Push-Pull type of audio amplifier.

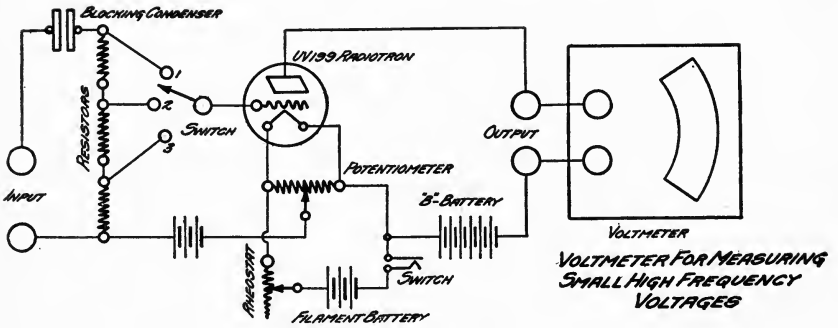

Fig. 75

Circuit diagram showing method of connecting up a vacuum tube voltmeter for measuring very small voltages.

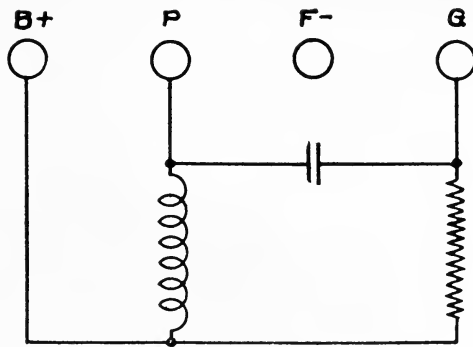

Fig. 76

PORTABLE CAPACITY BRIDGE

The measurement of small capacities is of great importance in several branches of radio work. In the design of delicately adjusted receivers it is necessary to give considerable attention to the inter-electrode (grid-filament, plate-filament, grid-plate) capacities of vacuum tubes. For this reason, the measurement of these capacities is of particular interest both to tube and receiver manufacturers. The very small capacities involved (about 5 micromicrofarads) render the usual type of bridge measurement not very satisfactory for this use. This type 383 Portable Capacity Bridge is particularly designed for this type of work.

A conventional type of bridge circuit, as shown in the following diagram, is used, consisting of two resistance and two capacity arms. It is actuated by a self-contained microphone hummer supplied by a 4½ volt dry battery. The output from the hummer, of about 800 cycles frequency is fed through a transformer to the bridge circuit. The transformer has shielding between the primary and secondary, and is in addition wound in two sections so as to reduce the capacity effects. The phones are supplied from another transformer, its primary connected across the bridge, the secondary brought to the two lower terminals shown in the photograph. Three adjustments appear on the bridge panel, marked Loss Adj., Zero Adj., and Capacity. These correspond with the condensers so marked in the diagram. The Loss Adj. condenser, shunted across the resistance arms of the bridge, compensates for the variation from zero of the power factor of the unknown capacity. This adjustment is not calibrated as it is not intended for use as a means of measuring power factor. It is merely to compensate for loss current in the condenser arm which might otherwise render a balance of the bridge impossible. It is generally necessary to make this adjustment only when rather high loss is associated with



Fig. 77
Portable
Capacity
Bridge.

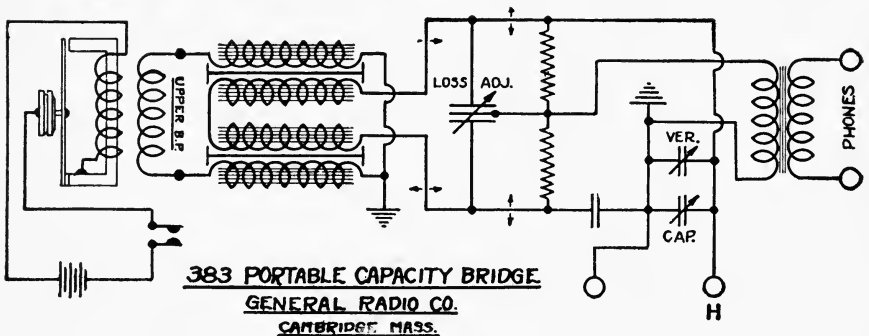

Fig. 78

the capacity under test. The Zero Adj. condenser is included across the balancing condenser and the unknown in order to balance out stray capacities of the leads, sockets, etc. As the ratio arms and standard condenser are fixed, the total capacity in the fourth arm of the bridge, which includes the unknown with its leads, the zero adjusting and the measuring condenser must be constant for balance. In making measurements the leads, sockets, or other apparatus associated are connected to the terminals and the capacity of the Zero Adj. condenser reduced sufficiently to balance the bridge with the Capacity condenser set at maximum capacity. The dial on this condenser is set to read 180 degrees out of phase with the capacity, i.e., the dial is set at 0 for maximum capacity.

The unknown capacity is then connected and the condenser marked Capacity rotated (reducing its capacity) until the bridge is again balanced. The Loss Adj. condenser is adjusted as required in each case. The capacity of the unknown condenser is obtained by multiplying the reading of the measuring condenser by a factor appearing on the dial.

A very convenient accessory in making measurements on the inter-electrode capacities of vacuum tubes is the socket shown in the foreground of the photograph. This socket is fitted with three prongs to

fit the binding posts of the bridge, and connected to grid, plate and filament. In measuring the tube capacities, this socket is plugged in and the bridge balanced for zero. The tube is then placed in the socket and its capacities measured directly.

Readings can be made to about one-half division on a one-hundredths division scale with ear phones, or somewhat more accurate if an amplifier and tube voltmeter are used.

This capacity bridge is made in two sizes, one with a range extending to thirty micromicrofarads and is for measuring small capacities; the other model extends up to 600 micromicrofarads and is particularly useful in matching condenser units used in single control setups. The accuracy of the instrument makes it very useful for this purpose, as it will show up small differences between such units than are permissible in the receiver. Its simplicity as compared with quartz-controlled oscillators and other expedients resorted to for condenser matching recommends it strongly.

A very useful adjunct to the capacity bridge is a two-stage amplifier as described in this chapter. A vacuum tube voltmeter can then be used to detect balance and a somewhat greater accuracy attained than is possible with earphones. Another advantage of the voltmeter is that it permits tolerance limits to be marked on the dial of the voltmeter, a useful practice in factory inspection.



Fig. 79

Portable Audio Amplifier with the Coupling Units on sockets, enabling the use of all the different coupling method, resistance, impedance, transformer, etc.

LABORATORY AMPLIFIER

The sensitivity of a great many laboratory measurements can be increased by the use of a properly designed amplifier. An amplifier also makes possible the substitution of a visual for an auditory balance of bridge circuits operating at 800 to 1000 cycles. This feature is of advantage, for example, with the Portable Capacity Bridge previously described. An amplifier is necessary also in making observation by means of an oscillaograph such as the type 338, where circuit conditions must not be disturbed by the measuring equipment. The audio coupling units are mounted on plug in type socket plugs so that any type of coupling unit desired may be used. This feature makes it possible to quickly determine the relative merits of different types of coupling units, low ratio transformer, high ratio transformer, Double Impedence, resistance, etc. The amplifier is for use with dry cell tubes and the cabinet is large enough to carry all the necessary B and A batteries.

VACUUM TUBE BRIDGE

The uses of the three-electrode vacuum tube has become so manifold that the study of its characteristics is of considerable importance. Several tube-testing devices have been developed and placed on the market. These usually consist of a series of meters and rheostats, with or without enclosed batteries, and are designed to check filament power and to measure certain so-called "static-characteristics," such as the joint emission to grid and plate or the steady plate current passing under any particular conditions of filament current or voltage, plate voltage and DC grid bias. From characteristic curves obtained in this manner the "static amplification constant" and other data of value may be determined. Under certain conditions, however, the "dynamic characteristics" of a tube are of more fundamental importance. To obtain such data it is necessary to apply an AC potential to the grid of the tube and to make use of certain balanced-bridge measurements.

The type 361A Bridge was developed to furnish an instrument which would not only provide for the easy and rapid measurement of filament emission and certain so-called "static-characteristics" but would also act as a direct reading bridge giving three fundamental "dynamic characteristics" of the tube, namely; the Amplification Constant, the Plate Resistance and the Mutual Conductance. To measure these dynamic constants the bridge must be supplied with current from an audio frequency tone source, preferably sinusoidal in character, and then balanced for a null setting in the telephone head set after the manner of an ordinary impedance bridge. The type 213 Tuning Fork Oscillator makes an excellent tone source for this purpose.

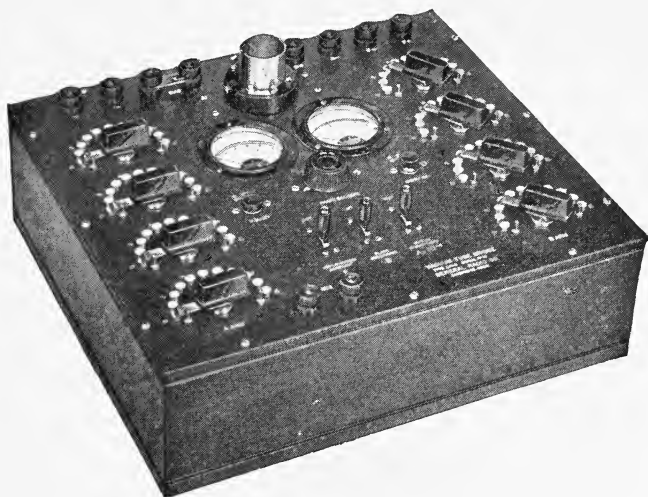

Fig. 80
Vacuum Tube
Bridge.

The bridge is designed to combine accuracy with great ease and speed of manipulation. All changes in the bridge to obtain the different circuits used are obtained by the use of throw switches. The balancing adjustments are on a dial decade scheme. There is no necessity for removing plugs or changing connections.

The tube to be measured is inserted in a detachable UX type socket, mounted externally on the panel of the bridge and fitted with an adapter for the smaller base tubes such as the UX199, etc. A ten volt Voltmeter is provided for measuring the voltages directly across the filament terminals, and by a multiplier, the "B" battery voltage. A five-milliamperere meter is used for measuring the plate current. This is equipped with a shunt extending its range to twenty-five milliamperes. Provision is made for inserting any desired "C" battery in the grid circuit. Thus, by varying the filament voltage, plate voltage and grid bias (by means external to the bridge) the data for the customary "static characteristic curves" may be conveniently read on the bridge meters. Routine inspection tests at definite voltages are, of course, quickly and easily performed.

The bridge is equipped with three telephone keys and two four-dial resistance arms, the proper manipulation of which enables the operator to determine quickly the three dynamic characteristics mentioned above for any particular specifications of filament voltage, plate voltage and grid bias. Thus, in a similar manner, the "dynamic characteristics" of a particular tube may be easily and rapidly obtained and research or routine inspection work greatly facilitated.

The resistances are of the non-inductive low distributed capacity type, and the bridge is adequately shielded. The input transformer has a shield between its two windings.

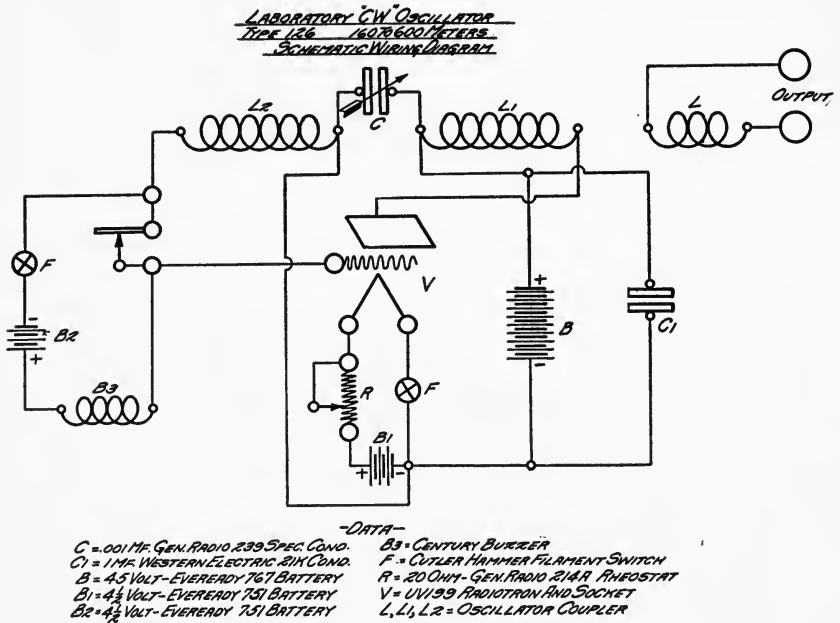

Fig. 82

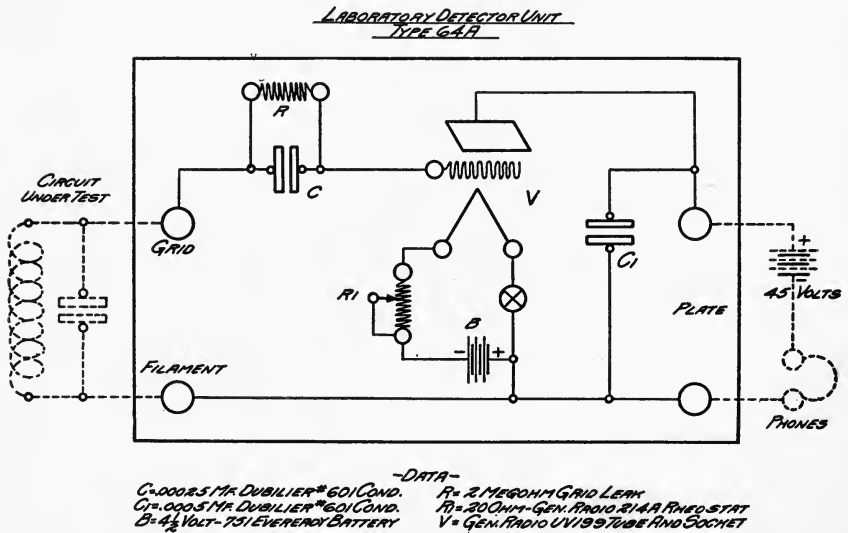

Fig. 81

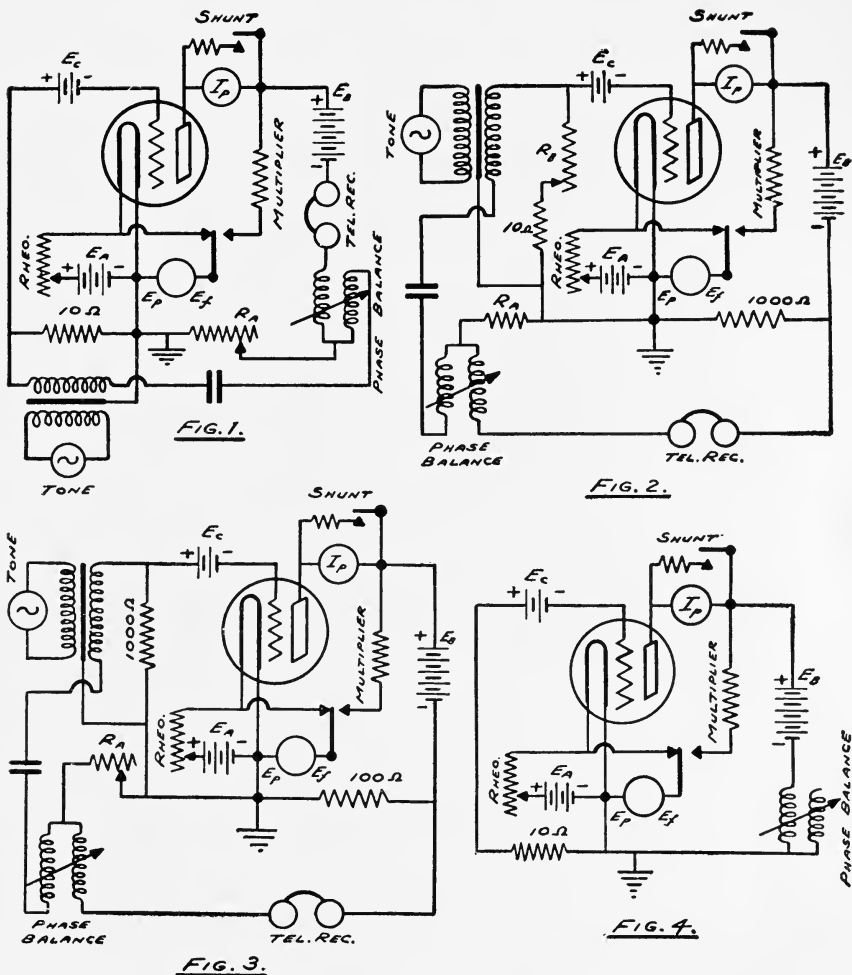

Fig. 83

The units constituting the bridge may be arranged in any of the accompanying circuits by manipulation of the key switches.

The circuit of Fig. 1, obtained by throwing the Key marked Amplification Constant, provides for the direct measurement of the voltage amplification constant of the tube under test. The resistance R_a (the four dial A-arm of the bridge) is adjusted until the drop through it due to current from the tone source balances the potential (UE_g) resulting in the plate circuit from voltage (E_g) impressed on the grid. Minimum tone in the telephones indicates the balance point. E_g results from the flow of current from the tone source through the 10 ohm resistor in series with R_a .

In order for no current to flow:

$$E_p = U E_g = R_a I_t$$

Where I_t is the current from the tone source

$U E_g$ is opposite in phase to $R_a I_t$

$$E_g = 10 I_t$$

$$U = R_a / 10$$

The resistance (R_a) is numerically equal to $10 U$, and the decade resistance system is calibrated in terms of amplification constant.

A variometer, by means of which the quadrature component of e.m.f. introduced by the tube capacity may be balanced out, greatly facilitates the balance. The constant may be read to two decimal places. The resistance provides for the measurement of amplification constants up to 100.00.

To measure plate resistance the bridge is set for the circuit of Fig 2. The value of amplification constant just determined is set on the A arm, and the bridge is balanced by adjusting the four dial B arm. It will be noted that R_a has been switched to the grid circuit and replaced by the 1000 ohm resistance. R_b has been added in the grid circuit. The condition of balance requires that the drop across the 1000 ohm plate resistance and R_a be equal.

$$\text{At balance, } R_a I_t = 1000 I_p$$

$$I_p = U E_g / (R_p \text{ plus } 1000)$$

$$E_g = I_t (R_b \text{ plus } 10)$$

Substituting and dividing: $R_a - 1000 (R_b \text{ plus } 10) U (R_p \text{ plus } 1000)$

$$\text{But: } U = R_a / 10$$

$$\text{Hence: } 100 (R_b \text{ plus } 10) / (R_p \text{ plus } 1000) \text{ equals } 1$$

$$\text{Giving } R_p = 100 R_b$$

R_b is calibrated to read directly in plate resistance.

As before use is made of the variometer in balancing out quadrature component in accurate adjustment of the bridge. Measurement may be made of plate resistance up to 100000 ohms in 10 ohm steps.

For measurement of mutual conductance, the bridge circuit is transformed to that of Fig. 3 (the 1000 ohm plate resistance of Fig. 2 is reduced to 100 and the grid resistance becomes 1000). Balance is obtained by adjusting R_a and the variometer.

$$\text{At balance: } R_a I_t = 100 I_p = 100 U E_g / (R_p \text{ plus } 100)$$

$$E_g = 1000 I_t$$

$$R_a = 100,000 U / R_p \quad (R_p \text{ is large compared to } 100)$$

$$U = R_a R_p / 100,000$$

$$\text{Mutal Conductance} = U / R_p = R_a / 100,000$$

Since the A arm is marked with $1/10$ of its true resistance:

Mutual conductance in mhos = reading of A arm $\times 10^{-4}$

Values up to 0.01 mho may be read in steps of one micromho.

Fig. 4 is the circuit for taking the static characteristics. The voltmeter is normally connected across the filament. Depressing a switch connects it across the plate battery, and throws in a multiplier. The maximum reading is 200 volts. The ammeter is provided with a shunt, reading 5 or 25 milliamperes maximum. A button type of switch controls the shunt.

This bridge is necessary for the intelligent design of tubes or receivers and also of great use in the college laboratory.

STRING OSCILLOGRAPH

In many lines of work and experimentation with alternating currents the need is frequently felt for a simple, sensitive, portable and inexpensive oscillograph, with which one may view with ease either sustained wave forms or transient currents and voltages existing at any point in an electrical circuit or net work. The type 338 Oscillograph meets these requirements and may be used for two distinct purposes:

1. As a string oscillograph which operates with much less power than is usually required by such instruments, but which affords a satisfactory means for the visual examination of wave forms over a wide range of frequencies. The wave of either current or voltage is traced by the shadow image of a very fine vibrating wire rather than by a spot of light reflected from a mirror attached to a moving system. The vibrating element can, accordingly, be made much lighter, resulting in an increased sensitivity of the instrument. The uses for such an instrument are manifold, as, for example: the observation of large or small alternating currents in the laboratory, power house, or class room; the visual examination of telephonic currents in simple or complicated circuits; the study of mechanical vibrations (when combined with some form of microphone or magnetophone) occurring in moving machinery or in bridges or other structures subject to intermittent stresses, etc. For many such lines of work the portable nature of the equipment is of especial value. If the oscillograph is connected in series with the loud speaker of a radio receiving set, an instructive and entertaining result will be obtained.

2. As a reliable vibration galvanometer, the string of which may be tuned to give a good degree of sensitivity at any desired frequency over a considerable range. In this respect the instrument is especially useful as a null point detector in A. C. bridge measurements when using low frequencies at which the telephone receiver becomes insensitive and otherwise unsatisfactory. As the galvanometer has no

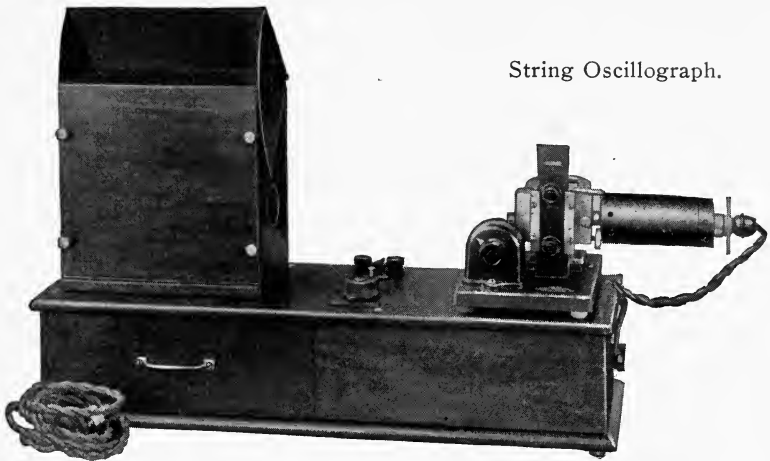

Fig. 84

coil in the magnetic field, its reactance is practically nil when the spring is not vibrating, a feature which is desirable for certain applications.

An idea of the sensitivity of the instrument may be obtained from the following data; using a string of .0004 inch tungsten wire, undamped, and tuned to the fundamental of the applied A. C. frequency, the following potentials are required to produce a wave form having an amplitude of one millimeter:

At 60 cycles	0.2 millivolts
At 250 "	1.0 "
At 500 "	2.4 "
At 1000 "	8.5 "

The D. C. sensitivity of the same string when tuned at various frequencies is seen from the following data, which gives the D. C. potentials required to give a deflection of one millimeter on the screen:

At 60 cycles	0.0047 volts
At 250 "	0.065 "
At 500 "	0.30 "
At 1000 "	1.31 "

The resistance of the instrument strung with the 0.0004 tungsten wire is of the order of 65 ohms. The appearance of the instrument may be noted in the photograph, six parts complete the equipment as follows: Galvanometer, rotating mirror box, oscillograph base cabinet, carrying case, an adjustable rheostat of 1000 ohms enabling the instrument to be used on voltages up to 500, and a step down transformer to adapt the oscillograph for efficient operation in high impedance circuits.

The galvanometer is mounted upon the right hand end of the cabi-

net. It is sensitized by two permanent magnets, thus eliminating the need of a source of direct current for producing the necessary magnetizing field. Two specially shaped pole pieces afford a long, narrow, vertical gap in which the string vibrates, and at the same time serve to support the optical system, which consists of a large and a small condenser lens, together with microscope objective. The large lens and the standard automobile headlight bulb used are located in the lamp chamber seen on the extreme right, while the two small lenses are located within a tube passing through the pole pieces. All three lenses are adjustable along the optical axis, while the lamp is adjustable in three dimensions. This makes it easy to focus the system to give a uniform field of illumination. A thumb-screw, located on the left end of the lamp chamber, slides the optical system as a whole with reference to the string and thereby focuses the shadow image of the same upon the observing screen.

The string is mounted upon a metal rocker arm, which, in turn, is attached to the rear of a vertical bakelite strip, shown in the photograph. Two adjustment screws will be seen protruding through the front of the strip. One of these varies the tension on the string, while the other serves to move the string across the beam of light in order to center the image on the screen. Provision is made for damping the vibration of the string, if desired, by means of two drops of oil. The whole string assembly is readily removable electrical contact being made through two springs on the galvanometer base. Two spring mountings are provided with this equipment, one strung with very fine tungsten wire about .004 inch in diameter, while the other is strung with a coarser wire. These strings which are each $4\frac{1}{2}$ inches in length, may be considerably overloaded without damage. As they carry no mirror, their replacement, if accidentally broken, is a comparatively simple operation.

On the left of the galvanometer base is mounted an enclosed potentiometer for adjusting the potential applied to the string, and hence controlling the amplitude of vibration.

On the left of the cabinet is mounted the mirror box, which is likewise made of walnut. This contains a rotating octagonal metallic mirror which affords the necessary time element of linear motion perpendicular to the vibration. The mirror is mounted on the shaft of the small induction motor and is provided with jewelled bearings. This motor is of simple construction, consisting of a circular disc, the periphery of which passes through a gap in a rectangular, laminated core. This core is energized by a high impedance coil carrying a 60 cycle current and is surrounded by two copper rings acting as "shading coils" around one half of the cross section of each coil. The unsymmetrical distortion

of the resulting field affords the driving torque. This motor is not inherently synchronous, as its speed may be controlled over a wide range merely by varying the voltage impressed on the energizing coil. This is done by means of a potentiometer, the knob of which is seen in the center of the cabinet. A very constant speed of any desired value may be maintained in this manner, which makes it easy to synchronize the motor to any frequency impressed on the string, producing thereby a stationery wave pattern. For observing transient phenomena of some duration, it is desirable to have the mirror run quite slowly, while the maximum speed of the motor is necessary to separate the individual wave forms at the higher frequencies. The 60 cycle wavelength at maximum speed is from $2\frac{1}{2}$ to 3 inches, giving a wavelength of about $1/16$ inch at 3000 cycles.

A screen bent on the arc of a circle is seen by looking down into the box, which is provided with an adjustable metallic cover that serves as a hood for shielding the screen when desired. The observer may stand at some distance from the screen and still watch the wave form while manipulating other apparatus, which is a convenient feature. A cylindrical lens is mounted in the mirror box for concentrating the light beam into a narrow line. This sharpens and intensifies the image considerably. The vertical wall of the mirror box is easily removable for inspection and adjustment of the enclosed parts.

Terminal posts, together with a cord and plug, are provided for attaching the equipment to a source of 60 cycle 110 volt current which may be conveniently turned on or off by a small toggle switch mounted in the center portion of the cabinet. This is the only source of power required, as the lamp is lighted through a small step-down transformer mounted in the cabinet. The whole instrument takes about 40 watts. The cabinet contains a 3 MF paper condenser which is frequently useful for eliminating a D. C. component from the string.

PIEZO ELECTRIC OSCILLATOR

The piezo electric properties of crystalline quartz make it particularly well adapted for use as a frequency standard. Plates of this material when properly prepared, and placed in the circuit shown, will hold the frequency within very narrow limits. The oscillating frequency is entirely dependent on the physical dimensions of the quartz plate which may be ground very closely to specifications. The frequency is practically unvarying with temperature and is not affected by any mechanical shock which does not fracture the plate.

The Type 275 Oscillator is entirely self-contained and consists of the components shown in the wiring diagram below, mounted in a suitable cabinet which includes all the necessary batteries. As the plate is

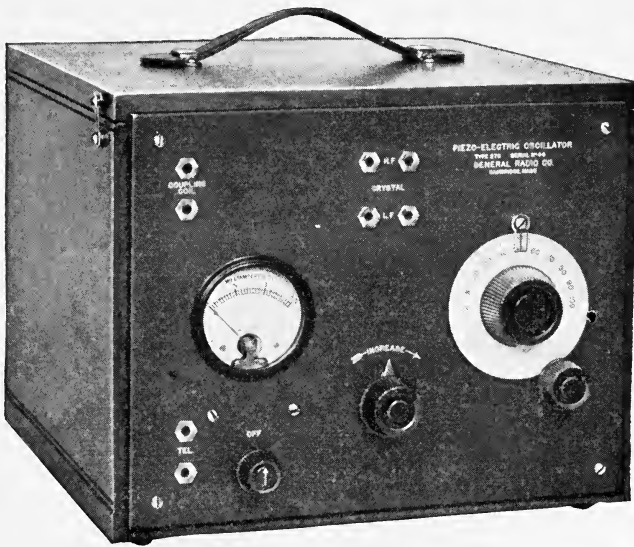

Fig. 85
Piezo
Electric
Oscillator.

mounted on the front of the panel with a plug-in arrangement, plates may readily be exchanged in order to extend the frequency range. The tuned circuit must be adjusted approximately to the frequency of the quartz plate, or the system will not oscillate. The system will oscillate only at the frequency determined by the plate, and not at the frequency of the tuned circuit. When the plate has several frequencies of oscillation, the tuning of the vacuum tube circuit determines the frequency at which the plate will oscillate. The coil is mounted externally and is suitable for coupling to other apparatus.

The oscillator diagram is shown. A UX199 tube is used as the oscillator. The meter mounted on the front of the panel indicates when the circuit is oscillating. The circuit between the plugs marked Tel. must be closed. Reasonable care must be taken in handling the plates, as they will fracture if subjected to too great a mechanical shock.

Limits are imposed on the fundamental frequencies for which it is possible to provide plates by physical conditions. The lower frequencies require very large plates while for the higher frequencies the plates are very thin, difficult to handle, and fragile. The practical limits at present are about 100 and 1500 kilocycles. Lower and high frequencies are readily obtained from these fundamentals, as the oscillator output is rich in harmonics.

When it is desired to use the weaker harmonics of the tube, an mental may also be obtained by means of the auxiliary tube. The auxiliary oscillator may then be tuned to the harmonics of the quartz-controlled tube by the beat method. Harmonics as high as the thirtieth

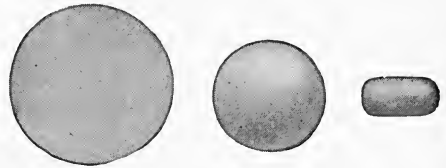
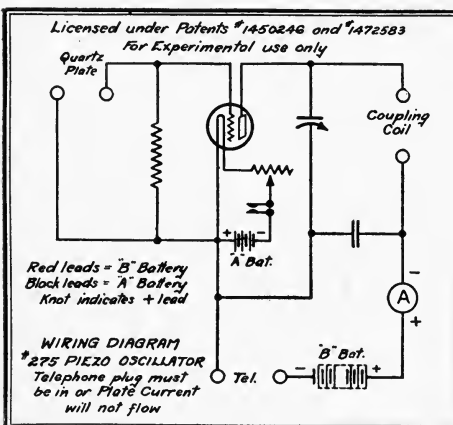

Fig. 86

Fig. 87
Piezo Crystals.

may be made use of by this method. Lower frequencies than the fundamental may also be obtained by means of the auxiliary tube. The auxiliary tube is adjusted to the lower frequency by tuning it for zero beat between its harmonic of the desired order and the quartz-controlled oscillator. By means of this device, a single plate may be used to obtain a great number of frequencies.

The plates are ground to three different degrees of accuracy, 25%, 5% and .1%. For controlling a transmitter the latter would be essential. For ordinary standards and comparison work, the 25% accuracy is sufficient as a calibration is supplied which is .1% accurate. This device is extremely useful for calibrating oscillators, wavemeters, receivers as well as for holding a transmitting station to the assigned wave. Through the use of these crystals, controlling transmitters, it is possible to operate two or more stations on the same wavelength without sufficient difference in wavelength to cause a beat note. Possibly in the future, the "chain" stations will all operate on the same wavelength, which would allow other wavelengths to be used to advantage.

Fig. 88
Circuit Diagram
Piezo Electric
Oscillator.

CAPACITY BRIDGE

For precise measurements of small capacities or accurate determination of dielectric losses the ordinary type of bridge is unsatisfactory, since the stray capacities in the circuit are or the same order of magnitude as the capacity to be measured. A bridge for the measurement of small capacitances requires complete shielding of all its elements.

The type 216 Capacity Bridge has been designed for this type of measurement. The elementary circuit shown, is similar to the type 193 bridge, consisting of three resistances, two ratio arms and a power factor resistance. The cabinet containing the bridge is copper lined and divided into several shielded compartments.

In order to isolate the bridge from stray capacity effects transformers with grounded shields between primary and secondary are used both at the input to the bridge and at the null detector.

As this bridge is designed for the measurement of small capacities, where the substitution method is used with equal total capacities in the bridge arms, the ratio arms are equal resistances. The use of equal arms without switches makes a very accurate adjustment of the resistances possible. As the arms are identical, any slight changes of power

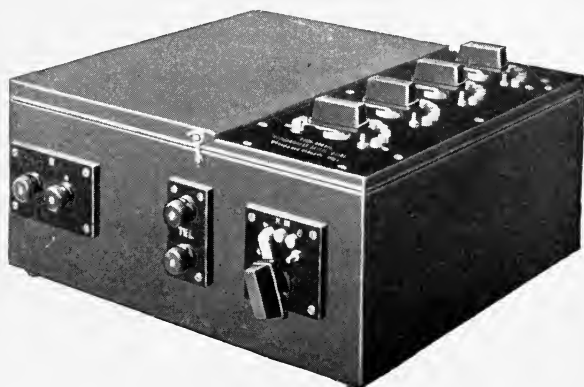

Fig. 89
Capacity
Bridge.

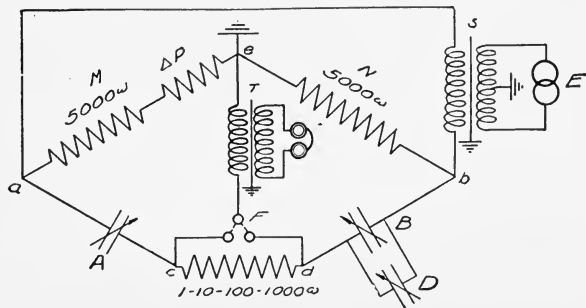

Fig. 90
Circuit
Diagram
Capacity
Bridge.

factor with frequency will balance and produce no resultant error. The third resistance arm may be connected in series with either capacity arm as required to balance the bridge. A switch (F) is provided for convenience in making the change. This resistance is a non-inductively wound decade box mounted in a shielded compartment.

It is very often desirable to calibrate a vernier condenser whose total capacitance is of the order of three or four micromicrofarads. For this work the bridge is first balanced, using capacitances of the order of 1000 micromicrofarads. If one of the resistance ratio arms were to be increased one part of one thousand i.e., from 5000 to 5005 ohms, the ratio of the capacitances would be changed accordingly, which is a change of one micromicrofarad. In order that the ratio arms may be changed in this manner resistance units are supplied with the bridge. These units may be added to either arm. Although the standard equipment of each bridge includes three of these resistance units so as to give ratios of unbalancing of .001, .01, and .1, they can be secured to give any ratio desired.

Since the impedance of small capacitances at 1000 cycles is high—that of 1000 micromicrofarads being 160,000 ohms—it is desirable that a high impedance detector be used to denote the balance point of the bridge. As the impedance at 1000 cycles of a pair of sensitive telephone receivers is only of the order of 20,000 ohms, it is evident that this is too low. For this reason a telephone transformer with a primary impedance of 200,000 ohms and a secondary impedance of 20,000 ohms is used. This arrangement provides the correct impedance in both the bridge and the telephone circuits and makes it possible to detect a very small difference in potential, such as that caused by the unbalancing of the condenser arms to the extent of one hundredth of a micromicrofarad.

In order to prevent errors due to capacity between the observer and the telephones, a grounded shield is used between the primary and secondary of this transformer. The junction of the two resistance arms is also grounded.

The accurately calibrated decade resistance arm provided for power factor measurements is valuable as a means of measuring dielectric losses.

The bridge is suitable for measuring capacitances up to .5 microfarads. The bridge is also suitable for the determination of the power factor of dielectrics. The resistance adjustment may be made to one ohm (the impedances measured are often in the neighborhood of 200,000 ohms). This single ohm, however, may be a considerable percentage of the change of resistance (R_c) and for this reason from 5-10% is a conservative figure for the accuracy of resistance measurements.

The testing of small samples of cables or the study of temperature changes in dielectrics is made easy because of the sensitivity of this instrument. An example of this latter use is a test made on a sample of hard rubber. The sample, which was three inches square and one half inch thick, was placed between two metal plates. At 54 degrees F, this sample had a capacitance of 11 micromicrofarads and a phase angle of 48'. When heated to 100° F, the capacitance had increased to 12. MMF. and the phase angle to 1° 55'. For the usual run of measurements the type 213 Oscillator may be used or for higher or lower frequencies, the type 377 Vacuum tube oscillator is best as it runs from 50 to 60 cycles up through the audio frequencies and into the radio frequencies.

SYNCHRONOUS MOTOR

In checking a source of constant frequency current great accuracy may be attained by using the source to drive a synchronous motor, and counting the motor revolutions over a long period. Synchronous motors may be built which will operate properly at audio frequencies. Higher frequencies may be checked by means of stepping down the frequency by means of a series of oscillators, with harmonics of the lower frequency oscillators adjusted to synchronism with the fundamentals of those of higher frequencies.

The type 411 Synchronous Motor is designed for use in calibrating frequency standards by this method. The motor drives a clock movement and when supplied with two-tenths of a volt-ampere at 1000 cycles will keep correct time. The motor will run from any source of 500 to 1800 cycles providing two-tenths of a volt-ampere.

The motor is not self-starting, but must be brought up to speed gradually. This is easily done by spinning the corrugated portion of

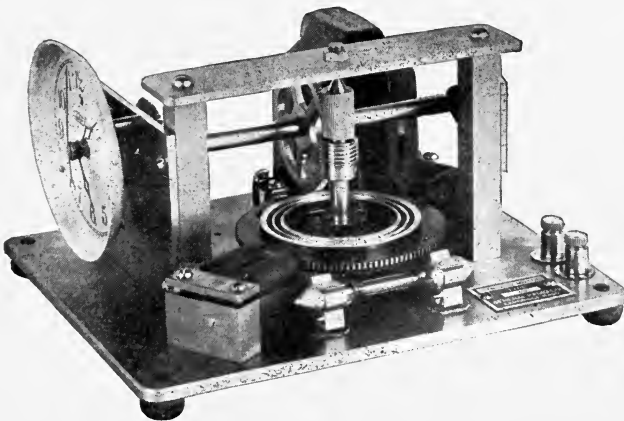

Fig. 91
Synchronous
Motor.

the shaft with the finger. The motor will not synchronize if it is run too fast and then is permitted to slow down by its own friction, as the pole pieces do not have a sufficiently strong magnetic effect to overcome the drag thus produced. A Neon tube operated through a transformer from this source, is placed beneath the periphery of the rotor. Looking through the rotor teeth at the Neon tube the teeth will appear stationary when the motor is in synchronism. The two grooves in the rotor should be about half filled with mercury to prevent hunting which is otherwise likely to occur with this type of motor.

The poles are not magnetized and it is therefore necessary to have about ten or fifteen milliamperes direct current also flowing through the winding. A satisfactory arrangement is to modulate a UX 171 tube from the source it is desired to measure and to connect the tube output directly to the motor (not through a speaker filter or transformer) and the normal plate current of about 12 milliamperes magnetizes the poles very satisfactory.

VACUUM TUBE REACTIVATOR

A large part of the vacuum tubes used in radio reception today have the so-called thoriated filaments. Chief among these are the Radiotrons UV and UX 199, 120, 200A, 201A, 171, 210, 213 and 216B and the corresponding Cunningham tubes and tubes of other manufacturers.

The electronic emission of these tubes, that is, their plate current, depends upon the presence of a layer of thorium atoms on the outer surface of the filament. The filament is not thorium-coated, however, after the manner of the oxide-coated filaments, but is, rather permeated throughout its whole substance with this rare element, thorium. During the normal operation of these tubes the thorium on the outer surface of the filament gradually evaporates. This would correspondingly reduce the emission current and render the tube very short-lived were it not for the fact that the thorium is continuously replenished from the interior of the filament. As long as the filament voltage in normal use is not raised over 10% above the rated value this evaporation and replenishing continues at an equilibrium rate, so that a constant layer of thorium is maintained on the surface.

When subjected to an overload voltage on the filament, however, the evaporation becomes excessive so that the thorium surface layer is partially or completely diminished, and the tube accordingly more or less paralyzed. Operating these tubes at sub-normal voltages is also liable to paralyze them slowly, as the filament temperature is then so low that the process of boiling out the thorium from the interior of the filament becomes abnormally retarded. Hence, it is important that the thoriated filament tubes be run at their rated voltages. It may



Fig. 92
Vacuum Tube
Reactivator.

be noted here that the maximum life of the "dry cell" tubes be attained when they are operated with a voltage of 3.3 across the filaments.

While the majority of thoriated tubes after a long and useful life gradually die a natural death, others are not infrequently executed by excessive voltages. In either case, if the filament is not actually burnt out, the chances are very good that the tube may be restored to life and vigor by the simple process of reactivation.

Before the cure we must diagnose the disease, and so before reactivation we should test the emission of the tube to ascertain if it is actually below normal. The following diagram shows the circuit used. The grid and plate are tied together directly and then joined to the plus terminal of the B battery through a milliammeter. The negative terminal of the B battery is connected to the negative end of the filament and a key switch, normally open, is included in the plate circuit. The voltage across the filament, read at V should first be adjusted to values given in the table accompanying, which also gives the proper plate voltage to use with each type of tube. These values should not be exceeded. The key is depressed long enough to secure a reading of the emission current on MA. Disregard the change in voltmeter reading caused by the emission current. If the emission current is zero or any amount less than that specified in the table, the tube can undoubtedly be improved by reactivation.

Reactivation can advantageously be accomplished in two steps; the first known as "flashing" and the second as "cooking." In both of these process the grid and plate of the tube should be left completely disconnected from any external circuits.

For flashing three volt tubes, a voltage of 12 is applied to the filament for a period of about one second. This will completely paralyze

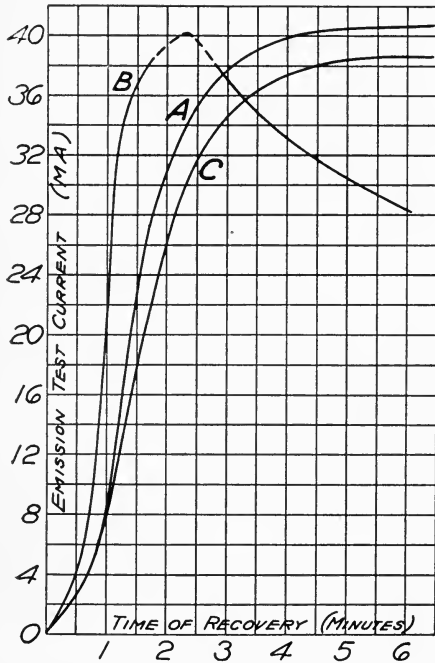

Fig. 93

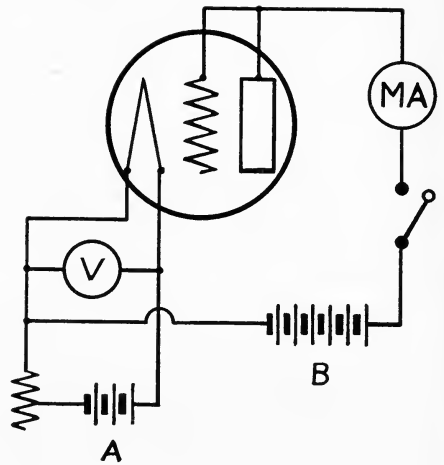

Fig. 94

Circuit for Testing Filament Emission.

the tube as the surface layer of thorium is wholly evaporated, but when the boiling out process within the filament is expedited by the flashing to such a degree that, if the tube is now cooked with a voltage of four across the filament, the surface layer will be rapidly replaced, so that, in a few moments, the emission of the filament will come back to normal and the rejuvenated tube is ready for another long lease of life. A constant "cooking voltage" of four is permissible in this case because there is no emission current to expedite surface evaporation.

If a subsequent emission test shows that the filament failed to respond to this reactivation process, it is evident that the tube has served its normal life or has been so heavily overloaded that its vacuum has been impaired.

The five volt tube should be flashed for the same interval at eighteen volts on the filament and cooked at 7 volts. Flashing is not recommended for the power amplifier UX210 or the rectifier tubes UX-213, and 216B. These tubes may, however, be reactivated merely by cooking them for longer intervals, the UX213 at six volts and the 216B at 9 volts, on the filament.

Curve A in Fig. 93 shows the customary normal recovery of a UX201A tube while cooking at 7 volts, after being flashed at 18 volts.

This recovery is slow at first, then increases rapidly, and finally slows down again as a saturation value is reached. When the tube was flashed at 18 volts and then cooked at its rated filament voltage, (5) the same saturation point was finally attained, but only after 35 minutes of cooking. Likewise recovery to the same saturation point, when cooked with four volts on the filament required a period of two and one-half hours. On the other hand cooking at nine volts on the filament caused a prompt recovery, but the saturation current was subsequently reduced, as shown in curve B, since in this case, evaporation from the surface (even with no emission current) exceeded the boiling out of the thorium from the interior.

Curve C shows the recovery of the 201A tube flashed at 12 volts and cooked at 7 volts. The rate of recovery and final saturation values are seen to be slightly less than curve B, where the same tube was flashed at 18 volts. The data for curve C was actually taken before curve B, so the results cannot be explained by a deterioration of the tube. Thus it is apparent that the recommended voltages for flashing and cooking should be used for best results.

It was found that tubes could be flashed six or eight times, on the average, before any decrease in saturation current, which would indicate a deterioration of the filament. The deterioration is not rapid, 12 flashings reducing the saturation current approximately 10 per cent. Accordingly reactivation might be expected to increase the useful life of an average tube threefold.

The type 288 Tube Reactivator is ideal for this work. It operates from 110 volts 60 cycles alternating current. No batteries or other apparatus are required. Sockets are provided where the correct voltages for flashing, and cooking are automatically obtained, without any adjustments, making the operation very simple. The emission of the various oxide coated filament tubes can also be tested, but of course cannot be reactivated.

Emission Table

Type of Tube	Fil. EMF	Plate EMF	Min. Emission
UV 199-299	3.3	50	6 m.a.
UX 120	3.3	50	15 m.a.
UX 201A	5.0	50	25 m.a.
UX 200A	5.0	50	12 m.a.
UX 171	5.0	50	50 m.a.
UX 210	6.0	100	100 m.a.
UX 213	4.0	100	50 per anode
UX 216B	6.0	125	100 m.a.

DECADE BRIDGE

Bridge methods have become standard practice for the measurement of inductance capacity and resistance. In all bridge circuits the voltage between two points in an electrical network is reduced to zero by balancing the voltage drop across the unknown with that across a standard. The balance or null point is determined by a suitable detector and the value of the unknown computed from the circuit constants. As a large number of bridge circuits have been developed it is desirable that a bridge for general laboratory use should be sufficiently flexible to enable it to be used in as many circuits as possible.

The type 193 decade bridge contains the resistances R_a , R_b , and R_c , shown in the diagram. The null point indicator may be connected so as to put R_c in either the unknown, or the standard arm. The resistances are non-inductive, being decade units.

The cabinet is finished with a polished copper lining to shield the resistance units from outside electrostatic shields.

Resistance Measurements. In making measurements of resistance the null indicator is connected between the points 2 and 3, and the STD posts connected together. R_c becomes the standard arm. The unknown is connected at X and the bridge balanced. The solution of the net work gives the equation:

$$R_x = R_a R_c / R_b$$

This method may be used for either direct or alternating current resistance by connecting a suitable source at E. For resistance measurements the accuracy of the bridge is .2%, if care is taken in balancing.

Inductance Measurements. The bridge is preferably set up with a switch such that the null indicator may be connected to either 1 or 3, placing R_c in either the unknown or standard arm as required. The function of R_c is to balance the bridge for resistance, since resistance as well as inductances must be balanced. R_c is connected in the arm having the lower resistance. As this is not generally known, the switch is convenient. The unknown is connected at X, a suitable standard at SDT and the bridge balanced. The solution of the net work gives the equation:

$$L_x = R_a L_s / R_b$$

As the bridge is also balanced for resistance, the resistance of the unknown is also indicated:

$$R_x = R_a (R_s + R_c) / R_b$$

if R_c was connected in the unknown arm or

$$R_x = R_a R_s / R_b - R_c$$

An inductance may be compared with a capacity by connecting the capacity across R_a . The unknown inductance is connected at the

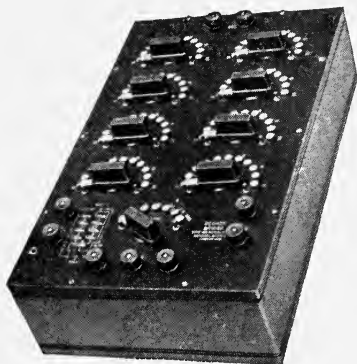

Fig. 95
Decade Bridge.

STD posts the null indicator to 2 and 3, and the X posts, connected together. The solution of the network gives the equation :

$$L_x = R_a R_c C$$

The accuracy of the inductance measurements is about .2% for air core inductances. Owing to the change of inductance with saturation it is impossible to obtain an exact balance with iron core inductances as the degree of saturation changes with every adjustment. The error is consequently greater in this type of measurement. The range for inductance measurements is from about 20 microhenries to several henries.

Capacity Measurements. For measurements of capacity the bridge is also set up with a switch for transferring R_c from the unknown to the standard arm. The unknown is connected at X and a suitable standard at STD. With the bridge balanced, the solution of the network gives the equation :

$$C_x = R_b C_s / R_a$$

As before the resistance balance gives the equation :

$$R_x = R_a (R_s + R_c) / R_b \text{ or } R_x = R_a R_s / R_b - R_c$$

depending upon the position of R_c .

The accuracy of the bridge for capacity measurements is .2%. Its range is from .01 to several microfarads.

Wagner Earth. When a telephone is used as the null indicator, difficulty may arise due to potential differences between the observer and the telephones. The charging current resulting prevents an exact balance. This difficulty may be overcome by the use of the "Wagner Earth" connection, which brings the telephone to ground potential. This is accomplished by means of the resistance R_m and R_n and the extra telephones T2 in the figure. The junction of R_n and R_m is grounded at J. With the switch open the bridge is balanced in the usual manner. Closing the switch, the secondary bridge consisting of $R_n R_m R_a$ and R_b

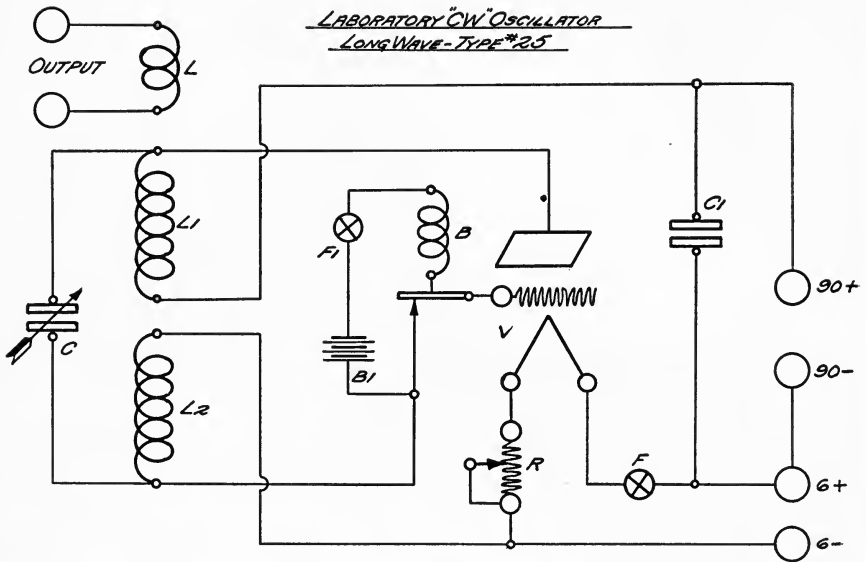

-DATA-

C = .001 MF. GEN. RADIO #239 SPEC. CONDENSER
*C*₁ = 1 MF. WESTERN ELECTRIC .21 KC CONDENSER
B = CENTURY BUZZER
*B*₁ = 4½ VOLT - 751 EVEREADY BATTERY
F = CUTLER HAMMER FILAMENT SWITCH
*F*₁ = CUTLER HAMMER BUZZER SWITCH
R = 20 OHM GEN. RADIO 214A RHEOSTAT
V = GEN. RADIO 156 SOCKET - W.E. 21G TUBE
*L*₁, *L*₂ = OSCILLATOR COUPLER

Fig. 96

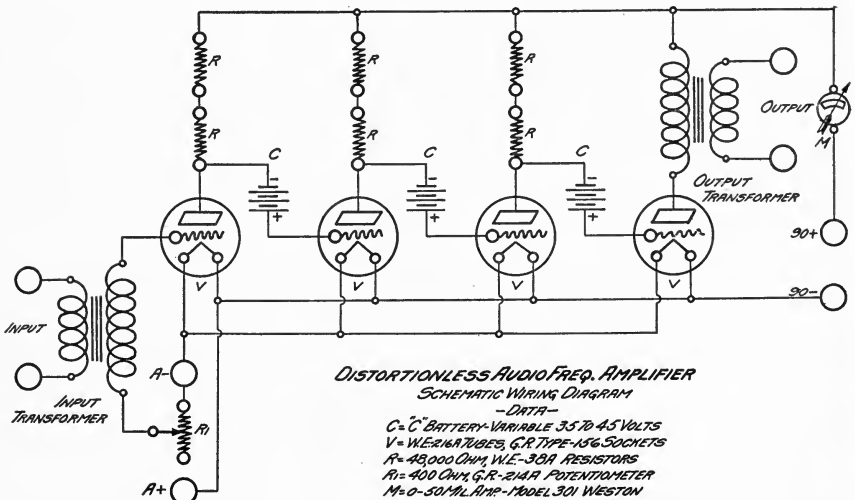

DISTORTIONLESS AUDIO FREQ. AMPLIFIER
 SCHEMATIC WIRING DIAGRAM

-DATA-

C = C BATTERY - VARIABLE 3.5 TO 4.5 VOLTS
V = W.E. 14A TUBES, G.R. TYPE 156 SOCKETS
R = 45,000 OHM, W.E. - 30H RESISTORS
*R*₁ = 400 OHM, G.R. - 214A POTENTIOMETER
M = 0-50 ML. AMP. - MODEL 301 WESTON

Fig. 97

Audio Amplifier with opposed voltages to fix grid bias values.

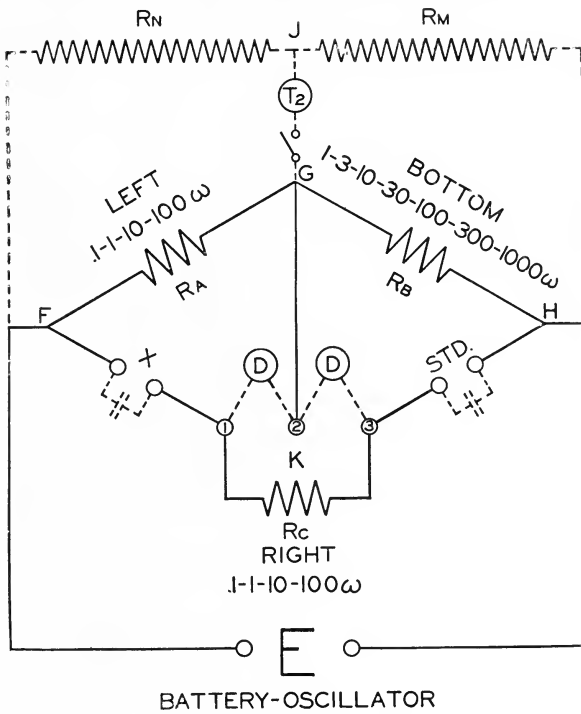

Fig. 98

is balanced using T_2 . All adjustments are of course made at R_n and R_m in order not to upset the balance of the bridge. When no current flows through T_2 D is at ground potential. The switch is opened, and the balance completed. R_m and R_n may be decade boxes.

Standards. When the bridge is used for resistance measurements, R_c is used for the standard. For inductance measurements the type 106 Standard is recommended. By proper choice of standards the bridge may be made direct reading.

Sources of EMF. For direct current measurements, a storage battery is of course used. For inductance and capacity measurements, either the 1000 cycles oscillator may be used where one frequency is desired, or the variable audio oscillator may be used for different frequencies.

Null point indicator. For direct current measurements a galvanometer is used. For alternating current a telephone headset or a vibration galvanometer. At 60 cycles the telephones are very unsatisfactory while the vibration galvanometer is quite sensitive. A two stage

audio amplifier is very helpful with both types of indicators. When making measurements of small capacitances or large inductances the sensitivity of the bridge may be increased by using in the detector circuit a telephone transformer, the high impedance side connecting across the proper GALV posts and the telephones to the low impedance side.

PRECISION CONDENSER

Condensers used as standards and for precision measurements must have many features not usually found in ordinary laboratory condensers. For variable standards it is essential that the plates be sufficiently rigid and well spaced so that handling the condenser will not change capacitance. It is not alone sufficient that the power factor be low, but it is also important that the dielectric losses be substantially constant throughout the entire range of the condenser. The type 222 Precision Condenser is intended for those places where precision is essential, rather than for use as an ordinary laboratory condenser. In its design, the mechanical as well as the electrical features have received special attention.

Mechanical. The plates are of heavy aluminum, widely separated by accurately turned spacers, and firmly clamped between substantial cast metal end-plates. A steel shaft, carrying the rotating plates, turns in cone shaped bronze bearings. The adjustment is locked after the condenser has been subjected to a rotation test to insure the proper fit of the bearings. The rotary plates are turned by a worm and gear, thus permitting fine control. The worm is held by spring tension in position

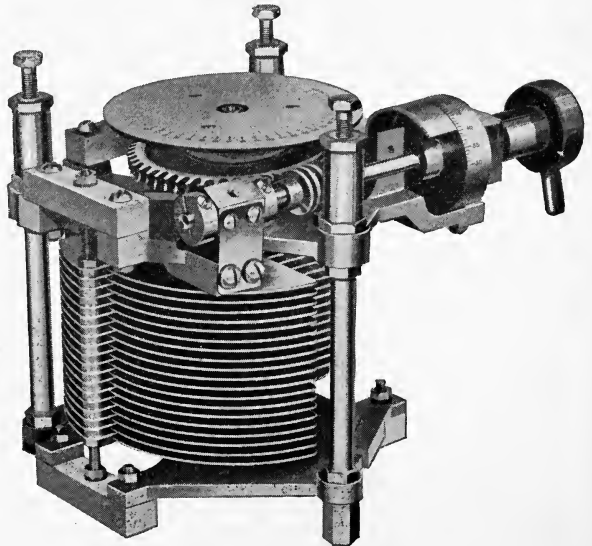

Fig. 99
Precision
Variable
Condenser.

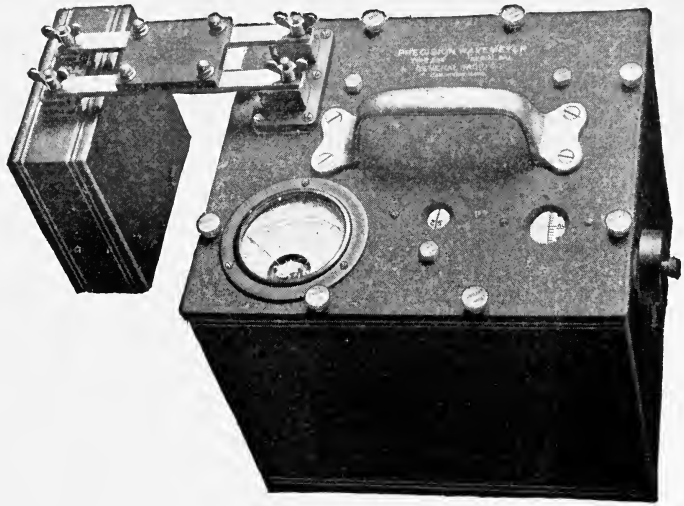

Fig. 100
Precision
Wavemeter.

against the gear to prevent backlash. This is the same method used in accurate dividing engines. The worm is lapped in to insure perfect fit and the condenser then tested for backlash in the laboratory.

Electrical. The stator plate assembly is insulated from the rigid end plates, carrying the rotor assembly, by Insultantite blocks. As these blocks are small in volume, and placed in a weak, non-varying electrostatic field, the condenser has a very low power factor, .007% at 1000 MMF.

When using this condenser in measuring the power factor of absorbing condensers the fact that the field, where the Insultantite supports are located, does not vary with condenser setting is of importance, because it permits the assumption that the precision condenser is the equivalent of two condensers in parallel, one being a perfect condenser of variable capacity, the other a small fixed condenser with which is associated all the dielectric losses. The temperature coefficient of the condenser is practically nil, and there is no change in capacity with frequency. The equivalent series resistance at 1000 cycles and 1000 MMF is approximately 11 ohms. The breakdown potential is about 1000 volts.

Scales and Calibrations. Attached to the main shaft is a scale divided into 25 equal parts, while on the worm shaft is a second scale the circumference of which is divided into 100 equal parts. Since one complete turn of the worm shaft moves the main scale through one division, the position of the rotary plates may be ready directly to 1 part in 2500—equivalent to about 0.6 MMF. Since these sub-scale divisions

are 1/16 inch apart, it is easy to estimate to one fifth of a division. Each condenser is supplied with a chart with an accuracy of 1 MMF, the condenser calibrated at 26 points.

PRECISION WAVEMETER

This wavemeter was designed to provide an accurate instrument for laboratory service, yet sufficiently portable for general measurement work where precision is essential. The type 222 Precision Condenser is used. Using this low loss condenser the tuning is very sharp. Of course the inductances are also designed and wound to have low distributed capacity, low dielectric losses, good form factor and reasonable amount of overlap in wavelength range. There are five inductances which cover a wavelength range of from 75 meters up to 24,000 meters. The simple circuit consists of the condenser, inductance and Weston Thermo Galvanometers.

The circuit is so connected that the condenser rotor plates, the condenser shield, the thermo galvanometer and the outside of the inductance coil are at low potential. This prevents disturbances due to variations and stray capacities.



Fig. 101
Direct
Reading
Wavemeter.

DIRECT READING WAVEMETER

The type 174 wavemeter is designed for general use in commercial and experimental radio stations. Its equipment is such that it is adapted for use with receiving or transmitting sets, employing either damped or undamped waves. Its self contained, direct reading features make this instrument particularly valuable for commercial work. A hot wire galvanometer is used for indicating resonance of transmitted signals of average intensity. For weak signals a crystals detector and binding posts for telephones are provided. For producing damped oscillations of known wavelength the wavemeter is equipped with a high frequency buzzer operating from a small battery in the cabinet. The oscillating circuit consists of three coils a selector switch and a variable air condenser. The inductance coils are bank wound in order to keep the distributed capacity at a minimum.

The dial on which are drawn the three wavelength scales corresponding to the three inductance coils is mounted directly above the variable condenser and is fastened to the rotor shaft. The scales are indicated by the numbers 1, 2 and 3 engraved on the panel. Above the galvanometer is a switch engraved RANGE with points numbered 1, 2 and 3. These three points correspond respectively to the three wavelength scales.

Receiving Sets. Two methods of determining the wavelength of a receiving set may be employed. The first, the reaction method, is applicable only to a vacuum tube receiving set, and then only when the set is oscillating. The wavemeter should be brought nearing the tuning inductance of the receiving set. By tuning the condenser of the wavemeter a sharp click will be heard in the headphones of the receiving set at the point where the condenser passes through the resonance point. The wavelength would then be read on the proper scale. It is usually necessary to have the wavemeter quite close to the receiving set. As the axis of the coils in the wavemeter is parallel to the panel, and extends from front to rear of the case directly beneath the galvanometer, best results are usually obtained by placing right hand edge of the wavemeter parallel to the tuning coil of the receiving set.

Where it is desired to set an inductively-coupled receiving set at a definite wavelength, the wavemeter should be set at that wavelength and the antenna circuit of the receiving set opened. The secondary of the receiving set should be adjusted either by means of the inductance or condenser until the reaction click is heard in the telephones of the receiving set. The wavemeter is then removed and the antenna connected again. The antenna circuit should then be tuned until a click is heard again in the phones. This will indicate that the primary and

secondary circuits of the receiver are both adjusted to the same value and to the value set on the wavemeter. This method requires of course, that the receiver be oscillating during adjustment. In a multiple tuned receiver which will oscillate without disconnecting the antenna, it is not necessary to remove the antenna.

A much quicker but slightly less accurate method way to adjust the receiver is by means of the buzzer on the wavemeter. The wavemeter is set at the desired wavelength and the buzzer turned on by means of the buzzer switch. The receiving set should then be adjusted until the maximum intensity of the buzzer signal is heard in the phones. This method of adjustment is similar to tuning to an incoming signal, only the incoming or artificial signal can be set to any wavelength desired.



Fig. 101A. Universal Super-8 Console, Complete Electric Operation.

TUNGAR CHARGERS

The name "TUNGAR" applies to the hot-cathode-gas-filled rectifier developed by the Research Laboratory in 1916. The name has no particular significance and was applied in order to reduce the length of the actual name of the device and to give a distinctive trade name.

It has been known for a number of years that a vacuum tube containing a hot and a cold electrode acts as a rectifier, and following these principles the Tungar was later developed.

THEORY OF OPERATION

In the Tungar bulb there is argon, an inert gas, at low pressure, which is ionized by the electrons emitted from the incandescent filament. This ionized gas acts as the principal current carrier, with the result that the bulb operates with a very low voltage drop (of 3-8 volts) and is capable of passing a current of several amperes, the current limit depending on the design and size of the tube.

Fig. 104 shows a simple half-wave bulb in which the cathode (lower electrode) consists of a filament of small tungsten wire coiled into a closely-wound spiral, and a graphite anode (upper electrode) of relatively large cross-section. All bulbs are constructed of high heat-resisting glass.

The bulb rectifies, because on the half cycle when the graphite anode is positive the emitted electrons from the incandescent filament are being pulled toward the anode by the voltage across the tube, colliding with the gas molecules and ionizing them; that is, making them conductive in the direction of anode to cathode; while on the other half of the cycle, when the anode is negative, any electrons that are emitted are driven back to the filament, so that the gas in the bulb is non-conductive during that half cycle.



Fig. 102

All Tungar bulbs are carefully exhausted to the highest possible vacuum and then filled with a gas in high state of purity. Certain impurities, however, even though present in very small quantities, produce a more or less rapid disintegration of the cathode, and also have quite a marked effect on the voltage characteristics of the rectifier. Means must be used to insure absolute purity of the gases from these foreign gases and to accomplish this, magnesium is introduced into the bulb, at the time of manufacture, chemically to react with such impurities as may be present. This reaction keeps the gas in a pure state practically throughout the life of the bulb.

The dark gray or silvery appearance of the bulb is caused by condensation of the purifying agent, magnesium, on the interior of the bulb during manufacture. This is not in the least detrimental to the bulb and does not give any indication of the life of the bulb.

The general principles already briefly discussed apply equally well to the half-wave and full-wave types of rectifiers. The half-wave rectifiers are particularly applicable to low-current low-wattage design on account of the much lower cost to manufacture and the lower cost of tube renewals. On larger sizes the lower power-factor makes them objectionable from the Central Station viewpoint although it should be remembered that two half wave rectifiers may be so connected to Central Station lines as to rectify both half waves.

Fig. 104 shows the connections of a half-wave rectifier in its simplest form. The equipment in this case consists of the bulb (B), with filament (cathode) (F) and anode (A), transformer, rheostat (R), and the load which is shown as a storage battery.

Assuming an instant when the side "C" of the alternating-current supply is positive, the current follows the direction of the arrows through the load, rheostat, bulb, and back to the opposite side of the alternating-current line. A certain amount of the alternating-current, of course, goes to excite the filament, the amount depending on the capacity of the tube. In actually designing the rectifier outfits the rheostat is omitted and the regulation entirely

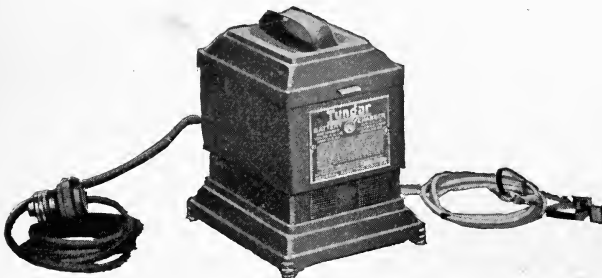

Fig. 103

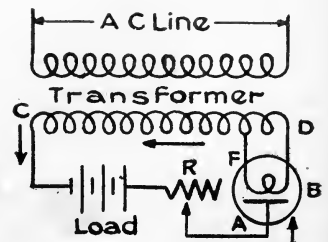

Fig. 104

obtained by means of a compensator, with which is combined the filament transformer, and a reactance. When the alternating-current supply reverses and the side (D) becomes positive the current is prevented from flowing for the reason before mentioned. In other words, the current is permitted to flow from the anode to the cathode or against the flow of emitted electrons from the cathode, but is cannot flow from the cathode to the anode with the flow of electrons.

Fig. 106 shows the general method of connecting two half-wave tubes with a single load and one compensator. In this case both waves are used and the resultant direct current is a pulsating unidirectional current which may be smoothed out as much as necessary, however, in ordinary battery charging. Of course, the resistance is omitted on commercial rectifier sets and a compensator and reactance substituted as with the half-wave sets.

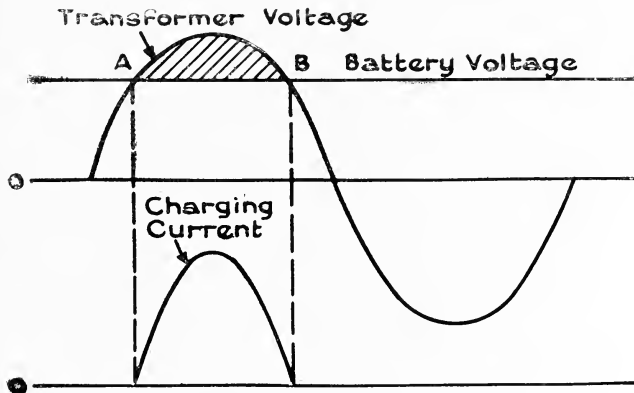

Fig. 105

BATTERY CHARGING TUNGAR

The principle on which a storage battery is charged from a Tungar is shown in Fig. 105. One cycle of half-wave rectification is shown. On the upper half of the cycle when the transformer voltage exceeds the battery voltage (Point A), the bulb anode becomes positive making the bulb conductive, and the charging current flows through the battery. When the transformer voltage falls below the battery voltage (Point B) the bulb is no longer conductive and the charging current ceases on the lower half of the cycle, the transformer voltage adds to the battery voltage and since the anode does not become positive, the bulb cannot conduct the current.

Tungars, particularly the half wave types, give a very pulsating current. However, this pulsating current will charge the batteries exactly as well as the non-pulsating current such as delivered by a direct-current generator.

The rated output of these rectifiers is based on direct current (D'Arsonval) instrument readings, which give the average value of the voltage and current. A direct-current ammeter indicates the true current which is effective in charging the batteries. If an alternating-current instrument is used, which gives the root mean square value of the current, on half-wave rectifiers, it will read from 75 to 100 per cent higher, and on full wave rectifiers about 25 per cent higher than the D'Arsonval type instrument. Both of these instruments would read identically on a direct-current or non-pulsating current.

ADVANTAGES

The Tungar Battery Charger has the following advantages:

It is simple to operate—skilled attendance unnecessary.

It is impossible for batteries to discharge if alternating-current supply fails.

Self-starting—simply turn on the alternating-current supply.

Bulb type charger—insures dependable, satisfactory battery charging.

Bulbs give long, uniform life.

Small and light in weight; even largest sets can be hung on wall.

No moving parts, grease or liquids; absolutely clean.

It is economical—low maintenance cost.

CAPACITIES OF TUNGARS AND BULBS

Tungar Battery Chargers are available in standard sizes capable of charging one 7.5-volt storage battery at 2 amperes up to an outfit large enough to charge 10 3-cell batteries at 12 amperes or 20 3-cell batteries at 6 amperes. The Home Type Tungars are also adapted to charge 120-volt "B" batteries at not over $\frac{1}{4}$ of an ampere. There are also many other special Tungars designed for various special requirements.

The Tungar bulbs range in size from $\frac{1}{2}$ -ampere capacity on 7.5 volts to 6 amperes at 75 volts and 30 amperes at 50 volts. The 2 and 5-ampere bulbs are designed to charge up to 120-volt "B" batteries at a low rate.

A general knowledge of the characteristics of Tungar bulbs is essential in designing a rectifying unit which permits the most efficient operation of Tungar bulbs.

Satisfactory operation of rectifying units using Tungar bulbs is largely dependent on careful transformer design and sufficiently liberal proportions to compensate for normal bulb variations and variations in a-c. line voltage.

CHARACTERISTICS

The characteristics of the Tungar bulb which affect the design of the rectifying outfit are as follows:

1. Filament voltage
2. Pick-up voltage
3. Arc drop
4. Flash-over voltage
5. Form factor of rectified current

It must be borne in mind that absolute uniformity in a product such as the Tungar bulb is practically impossible. Uniform manufacturing methods will give a fair degree of uniformity and a rigid inspection will serve to hold within reasonable limits such variations as may occur.

FILAMENT VOLTAGE AND CURRENT

Best operation and longest life will result if the filament voltage is adjusted to conform to the load conditions on the rectifier as noted in the following tabulation. At no load the filament voltage should be relatively high to insure that the bulb will pick-up but the voltage should be lower when the bulb is rectifying.

CAT. 289881		CAT. 195528 AND 277465 277465		CAT. 189048 AND 189049	
0.6-Ampere Bulb				6-Ampere Bulb	
Operating Current	Filament Voltage	Operating Current	Filament Voltage	Operating Current	Filament Voltage
No load	2.0 volts	No. load	2.2 volts	No load	2.5 volts
0.1 amp.	1.95 volts	0.5 amp.	2.1 volts	1 amp.	2.4 volts
0.3 amp.	1.86 volts	1 amp.	2.05 volts	3 amp.	2.3 volts
0.6 amp.	1.8 volts	2 amp.	2.0 volts	6 amp.	2.2 volts

The filament excitation current is preferably determined by the voltage applied across the filament. However, for use in designing the transformer the following approximate values of filament excitation current are given:

Cat. No.	Filament Current
289881	6 amps.
272465—195528	12 amps.
180948—189049	18 amps.

Automatic regulation of the filament voltage can be obtained by designing the transformer with a drooping characteristic if the rectifier is to be operated at varying load values. This feature is also desirable for regulating the output.

It is possible to cut off entirely the filament excitation after the arc has once been established but there are several serious objections as follows:

1. The arc tends to concentrate on some one point on the filament which reduces the life of the bulb.
2. Other characteristics, particularly the "Arc-Drop" and "pick-up" voltage are adversely affected.

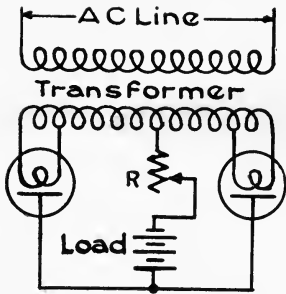

Fig. 106

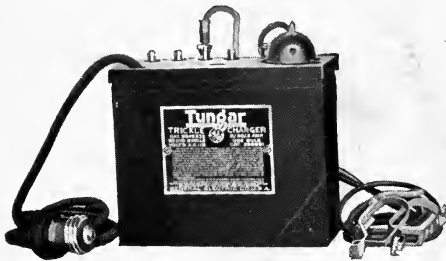

Fig. 107

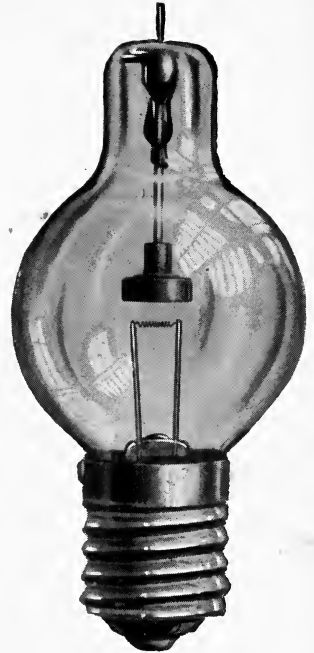

Fig. 108

3. Operation becomes very erratic.

4. From a battery charging standpoint the automatic starting feature is lost and the operation of the charger is complicated.

“PICK-UP” and “ARC” VOLTAGE

“Pick-up” voltage is the value of voltage which must be impressed across the bulb from plate to filament in order to start the rectifying action. As soon as current starts to flow through the bulb this voltage drops to a much lower value termed “arc-voltage” which is approximately constant regardless of the load current.

Cat. No. of Bulb	PICK-UP VOLTAGE		ARC VOLTAGE	
	Average	Limits	Average	Limits
289881	10 volts	8 to 12 volts	7.5 volts	5.5 to 8.5 volts
195528 }	11 volts	9.5 to 15 volts	7 volts	5 to 9.5 volts
277465 }	12 volts	11 to 16 volts	7 volts	5 to 10 volts
189048	13 volts	12 to 18 volts	8 volts	6 to 11 volts
189049				

It is important that the transformer secondary voltage be sufficiently high to insure “pick-up” under all conditions of line voltage. This minimum voltage may be insured by designing a transformer operating normally on a 115-volt a-c. circuit so that a number of bulbs representing the average will pick up and deliver some current at 90 volts. Incorrect filament voltage will also tend to cause unstable operation.

The recommended minimum secondary voltage for a 6-volt battery load is 25 volts in the case of the Cat. 289881 bulb and 30 volts for the other bulbs mentioned. Regulation in the form of reactance in the transformer or resistance either inherent in the transformer or connected externally must be provided in order to limit the charging current.

“FLASH-OVER” VOLTAGE

If too high voltage is impressed across a Tungar bulb in the direction of filament to plate the bulb will “flash-over” and this may result in the destruction of the bulb. If the Tungar is operating on a battery load the strain to which the bulb is subjected will be the battery voltage plus the peak value of the secondary a-c. voltage. On a resistance load a higher a-c. voltage can be safely applied. With an inductive load, however, the same bulb might flash over with a much lower secondary voltage due to an inductive “kick-back.” The following tabulation lists the normal voltage ratings of the standard high-voltage Tungar bulbs.

Cat. No. 277465 189048 189049	Normal Ratings 75 volts at 2 amperes 125 volts at ¼ ampere 75 volts at 5 amperes 125 volts at ¼ ampere 75 volts at 6 amperes
--	---

FORM FACTOR OF RECTIFIED CURRENT

Form factor, while not strictly a Tungar bulb characteristic, is of considerable importance in any case involving a pulsating direct current such is obtained from a rectifier.

An alternating-current instrument (moving vane type) and a direct-current instrument (permanent magnet type) will both give the same indication on a uniform direct current, but on a pulsating direct current the a-c. instrument will show a higher reading.

The a-c. instrument reads the root-means-square value of the wave whereas the d-c. instrument reads the simple average. The ratio of the a-c. instrument reading to the d-c. instrument reading is called the “Form Factor” of the wave.

Form Factor=

A-c reading	root-mean-square
D-c. reading	average

Obviously form factor can never be less than unity. The form factor of a uniform direct current (such as would be obtained from a storage battery) is 1.00. The lower the form factor the nearer is the approach to a smooth direct current.

Theoretically, the output of a simple one-bulb rectifier would be a

half wave of sine form with only one-half wave per cycle. The theoretical form factor would be 1.575.

Under actual conditions the shape of the wave will vary considerably and the form factor can be determined only by experiment.

The r.m.s. value of the current is the heating value, whereas the average value is the effective value in charging a storage battery.

In designing a rectifier for battery charging the output rating must be based on the average value of the current. However, the transformer winding, fuses and any wiring in the charging circuit must be capable of carrying the heating value (root-mean-square) of the current.

COUPLING METHODS

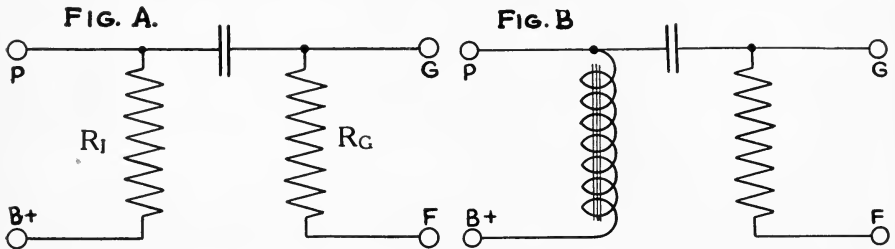

While methods of coupling between vacuum tubes at audio frequencies may be broadly divided into but three classes; resistance, impedance, and transformer coupling, these methods contain many subdivisions which raise the total number of possible methods of coupling to a surprising figure.

Figure A is the usual resistance coupled amplifier. R_I which determines the input resistance of the device should be several times the plate resistance of the tube out of which the coupling device is working. The size of the coupling condenser and of R_G may vary over a considerable range, depending upon the characteristic desired. For an efficient voltage transfer, R_G should be large compared with the input impedance of the tube. The capacity of the condenser will depend on the frequency range it is desired to cover, and on the value of R_G . It may be one-half to one microfarad where the frequency range extends well below one hundred cycles. A large condenser is sometimes viewed with disfavor on the ground that it causes "blocking" in the amplifier. Blocking will not occur, however, unless the grid of the amplifier tube is allowed to become positive. Proper biasing will prevent this. The principal advantage of resistance coupling is well known. It is the method of coupling by means of which a good frequency characteristic may be obtained

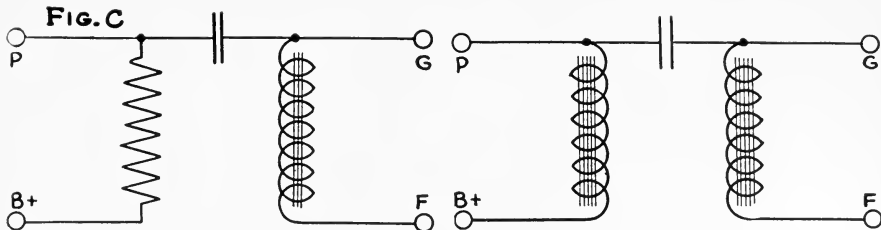

with least first cost. It has, however, the rather serious objection that the high input resistance causes a large drop in voltage between the source of plate power and the plate of the tube. Unless a rather high voltage is used at the source, the tube is not operated at the best part of its characteristic, and harmonics may be introduced. In all types of coupling devices where a condenser is used in the grid, care should be taken to keep the capacity of the condenser to ground at a low value.

The arrangement shown in Figure B is derived from that of Figure

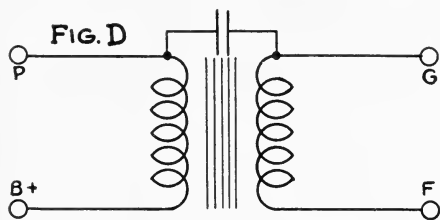

A by substituting an impedance for a resistance as the input device. This has the advantage of a comparatively low voltage drop, and with proper design, can be made to cover any desired frequency range. The impedance of the choke should be several times the plate impedance of the preceding tube at the lowest frequency which it is to amplify.

The methods of Figure A and B can be modified as shown in Figure C. In these circuits an impedance is used in place of a resistance in the output circuit. This arrangement is recommended where there is danger of grid current flowing momentarily, as on occasional loud signals, particularly in the last amplifier stage.

In the circuit of Figure C, the plate and grid coils are generally on different cores and are not magnetically coupled to each other. In Figure D, both coils have been put on the same core to form a 1:1 transformer, but the condenser has been retained and provides sufficient capacitive coupling at high frequencies to reduce any tendency toward resonance at high frequency due to magnetic leakage.

In the circuit of Figure E, advantage is taken of the step-up in voltage obtained by the auto-transformer connection. This feature increases the volume per stage, and may be combined with any of the systems of Figures A to D.

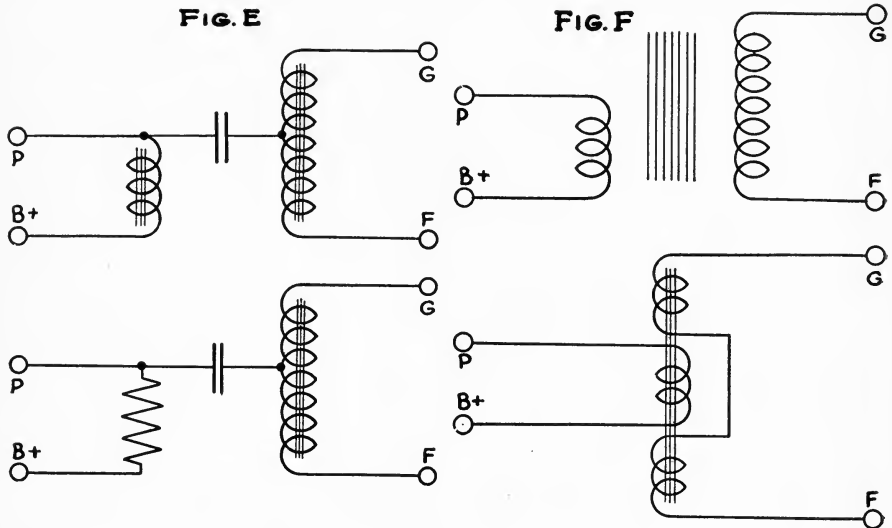

Figure F is the usual form of transformer. Proper design calls for an input impedance which is high in comparison with the source out of which it is working. The great advantage of this type of coupling is, its superior efficiency in consequence of the gain in voltage in passing through the transformer. In the transformer illustrated in the lower part of Figure F, the primary is inter-leaved with the secondary. This increases the coupling between primary and secondary, and reduces any tendency to resonance due to leakage flux.

Figure G, represents an adaptation of the principle of Figure D to a transformer of other than unity ratio. The condenser is connected to the secondary at the point where the secondary induced voltage is equal to the primary impressed voltage. The presence of the condenser reduces any tendency toward a resonant peak at the higher frequencies. This connection may, of course, also be used in conjunction with an inter-leaved primary.

In the circuit of Figure H, the portion of the transformer secondary between the condenser tap and the filament has been replaced by a resistance. If the grid leak is connected across the entire secondary, i. e., from grid to filament, there is some sacrifice of volume, but resonant peaks are suppressed. The coupling condenser may be placed near the grid and the winding made with a tap, instead of in two sections. There is some advantage in placing the coupling condenser as shown in Figure H, as capacity to ground from the large (physically) coupling condenser is reduced.

The circuits of Figure I are conventional for amplifying direct volt-ages.

Resonant peaks may be suppressed by means of any of the methods illustrated in Figure K. Resistances may be connected across either the primary or the secondary, although they are generally more effective across the secondary. A resistance of 200,000 ohms across the secondary will make even a rather poor transformer perform satisfactorily. Amplification will, of course, be greatly reduced. Resonant peaks will also be reduced by the short-circuited third winding.

For some purposes, it is not desirable to pass a wide band of frequencies. In such cases, tuned coupling devices as shown in Figure L should be used. The push-pull amplifier shown in Figure J has several advantages. One is greater undistorted output than is possible with two tubes in parallel or a single tube. Even harmonics are eliminated. As most of the harmonics introduced by tube overloading are even, this permits operation of the tubes at heavier loads than is possible with the usual system. Another advantage is the elimination of D. C. magnetization of the output transformer core, as the direct current flows in opposite directions from the two tubes. Auto-transformers may, of course, be used in the push-pull amplifier.

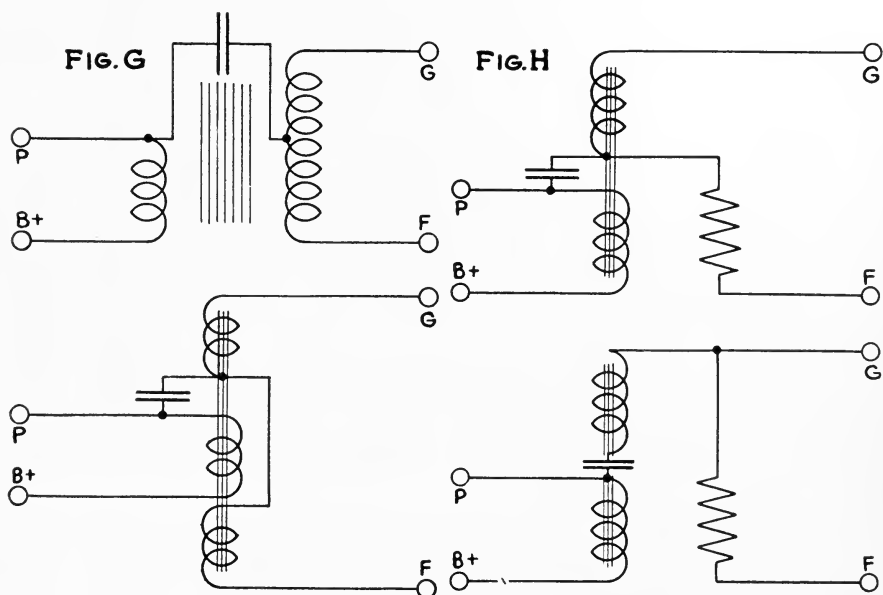

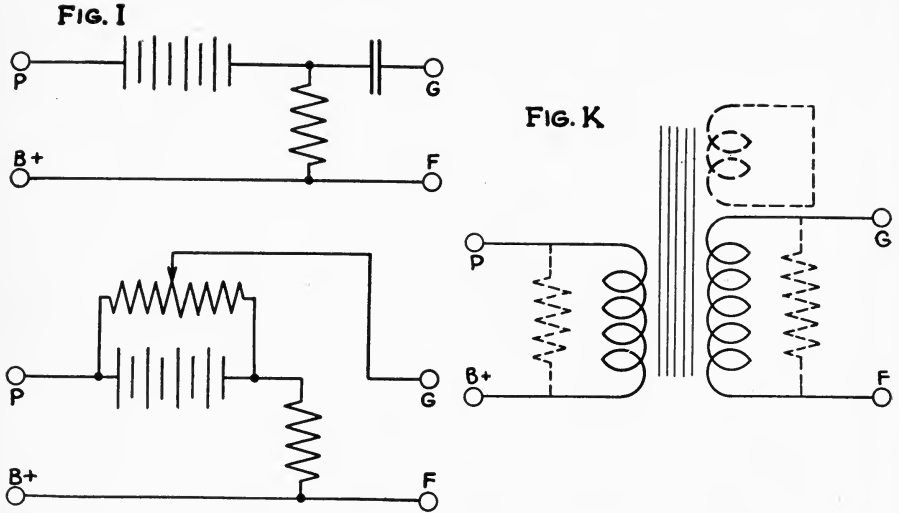

AMPLIFIER

"All that goes up must come down," is a familiar axiom. If we could establish for radio a parallel axiom, "All that goes in must come out," the radio millennium would be reached. Designers are steadily approaching this goal, and the progress of the last few years has been enormous. During the last year particularly has the swing been toward getting out more of what went in, rather than getting more in. That is, the fad for "getting" stations is passing. In its place is arising a demand for natural reproduction. This is a problem of getting out all that went in, for if some notes are subdued or lost, in passage through the set, the reproduced music will not sound natural. This newly critical attitude refuses to regard radio as a marvel, to be accepted in silent wonder in spite of any shortcomings. The radio is forced to stand comparison with other forms of entertainment on its merits as a musical instrument. This attitude is the compelling force behind the recent great improvements in audio amplifying and reproduction devices.

The problem of "quality," by which is meant the accurate and faithful reproduction of the matter sent into the air at the broadcasting station, is three-fold, embracing tubes, transformers, and loudspeakers. As each phase of the subject is worthy of individual consideration, only the second, that of transformers, will be considered here. The other two should not be forgotten, however, for the amplifier cannot be much better than its poorest element. Perfect transformers will not compensate for improperly biased, overloaded tubes or a squawky loudspeaker.

As it is not possible to invite all my readers into the laboratory

to hear the tests I am about to describe, it is necessary to devise a means of putting the result on paper, so that they can use their eyes to judge instead of their ears. The means of doing this is to reproduce the "amplification curve." The data for this curve is obtained by measuring the amplification at a number of frequencies. A curve is plotted of amplification against frequency, and as the principal source of transformer distortion is unequal amplification of different frequencies, a study of this curve shows even more definitely than the ear could just what is the relative rating of two amplifiers. It is not necessary to have the curve a straight horizontal line, which would indicate the perfect amplifier. A variation of twenty-five per cent would not be perceptible to the average ear. The frequencies above five thousand may be lost without serious loss of quality. The curve should remain high for frequencies at least as low as one hundred cycles. Probably the most interesting part of the curve is that between one hundred and five hundred cycles. Most of the older transformers failed to amplify in this range, and its full amplification is essential to natural sounding music. In order to study this part of the curve, which is crowded at the lower end, more easily, a special method of plotting the curves has been resorted to. Instead of making the distance along the frequency scale proportional to frequency, it has been made proportional to the logarithm of the frequency. The effect is similar to that obtained with the "straight line frequency" condensers now so popular. The lower end of the curve is opened up, spread over more space.

Just how much transformers have improved during the last few years is apparent from the curves of figure 1, which show the characteristics of four transformers of different vintages. Transformers No. 1 and 2 are of the older types designed before the period of development

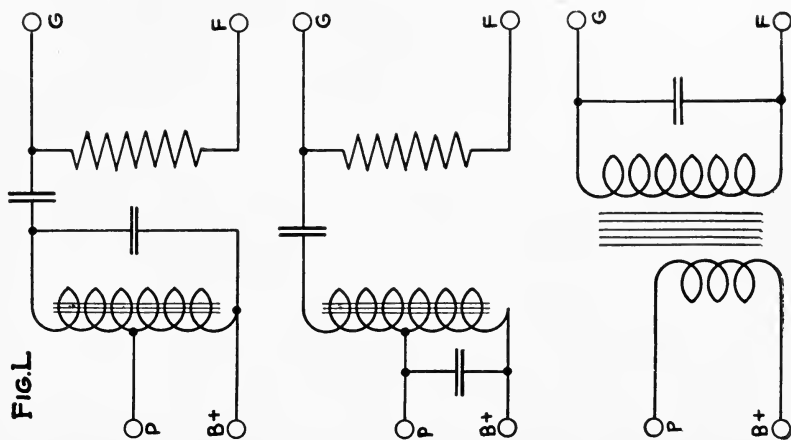
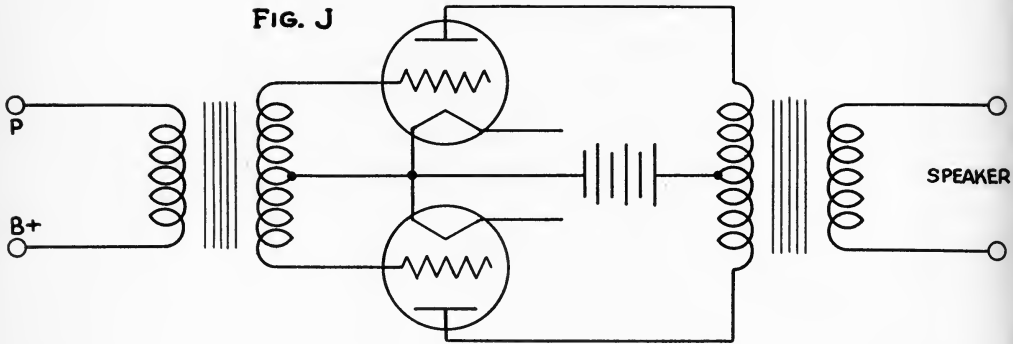

FIG. J



of quality reproduction. No's. 3 and 4 are both "new era" transformers. The difference between the new and the old is very noticeable. No. 1 has a marked peak at about eight hundred cycles. This frequency would be amplified to a much greater extent than those above and below, resulting in bad distortion. No. 2 lets through practically nothing under one hundred cycles and has but half its maximum amplification at four hundred cycles. Many frequencies that go into this amplifier do not come out. The result of this type of distortion, the loss of the low frequencies, is to give music a harsh mechanical sound. The transformers of curves 3 and 4 are a vast improvement over these earlier types, and are typical of several transformers making their appearance during the past year. The deviation of the maximum and minimum from the average amplification over this range is so slight as to be barely noticeable to the ordinary ear.

An interesting and important fact is discovered when the turns ratio of these four transformers is considered. No. 1 had 8.5:1, No. 2, 3:1, No. 3, 2:1, No. 4, 6:1. Note that the 8.5:1 transformer has a lower amplification than the 6:1 over practically the entire frequency range, and at both ends passes below even the 2:1. Another interesting point is that the 3:1 transformer distorts to a much greater extent than the 6:1, despite the popular idea that low ratio transformers necessarily have better characteristics than those of high ratio.

It was not entirely without reason that high ratio transformers have been viewed with some suspicion. Notice again the curve of the 8:1 transformer. This is typical of the older style high ratio transformers. The loss of the high frequencies is easy to understand. The coil capacity acts as a bypass for these frequencies, short-circuiting them to ground. The loss of the low notes is due to the fact that the primary turns were kept low in order to get high turns ratio with a small coil. The result of this practice may be explained with the assistance of the curves of Figs. 2 and 3.

Fig. 109. A group of representative transformers. The superiority of the new types (curves 3 and 4) is marked.

In the audio amplifier, the transformer primary is connected in series with the plate impedance of the tube, which is about 15,000 ohms for the common types of receiving tubes. A considerable portion of the voltage supplied by the signal is used up in this impedance. The portion of the voltage left across the transformer primary depends upon the relation of transformer impedance to the total impedance of transformer and tube. Thus if the tube impedance is 15,000 ohms and the transformer impedance 30,000, two-thirds of the voltage will be impressed across the transformer primary. It will now be seen why a high ratio transformer sometimes gives less amplification than one of low ratio. Suppose a 5:1 transformer had 150,000 ohms impedance at a certain frequency. Another transformer with an 8:1 ratio has but 15,000 ohms impedance in the primary. Both are used

Fig. 110. The result of varying plate impedance on a transformer of low primary impedance. When the plate impedance equals that of the ordinary receiving tube (12,000-15,000 ohms) the curve is badly peaked.

with a 15,000 ohm tube, with 10 volts available. The 5:1 transformer will have $150,000/165,000$ of 10 volts or 9.3 volts across the primary. Assuming no losses the secondary voltage would be 47 volts. Only $15,000/30,000$ or 5 volts will be impressed across the primary of the 8:1 transformer, with a secondary voltage of 40.

As the transformer impedance varies with frequency, while the tube impedance remains constant, the input to the transformer varies over the frequency range. This of course results in distortion (unequal output of different frequencies). Distortion due to this cause can be reduced by means of a high primary impedance. The input to the transformer cannot be greater at any frequency than the tube voltage. If at the lowest frequency it is intended to amplify, the transformer impedance is three times the tube impedance, the input will not be less at any frequency than 75 per cent the tube voltage, that is, not more than 25 per cent difference in amplification of different frequencies can occur. On the other hand, if the transformer has but half the tube impedance at this frequency, the difference will be 65 per cent.

The curves of figure 2 were taken on transformer No. 1, using different values of plate resistance. If the plate resistance could be reduced to zero, even this transformer would give little distortion. The curve becomes more and more peaked as the value of R_p is increased, and the amplification per stage is greatly lessened. In figure 111 is shown a similar group of curves for transformer No. 4. This is

a transformer of high primary impedance, 155,000 ohms at 1000 cycles as compared to 15,000 for No. 1. It will be seen that while the curve is better for the lower plate resistances, the difference is much less marked than in the case of No. 1. The advantage of a tube of low plate impedance is obvious. That is one of the advantages of the new R. C. A. tubes.

We have shown the essential requirement of equal amplification of all frequencies to be a high and nearly equal impedance at all frequencies. This is accomplished by the use of many turns of wire, with a large core of high permeability steel, and by proper coil design, avoiding capacity that acts as a bypass for high frequency. This requirement may be met in a transformer of high ratio as well as one of low.

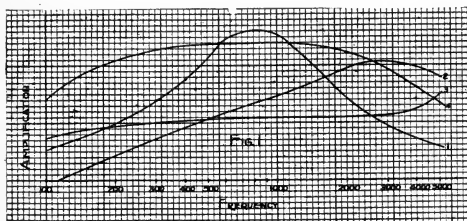

Fig. 109

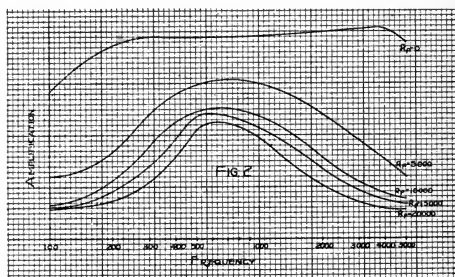

Fig. 110

So far we have been dealing with the problem of the manufacturers. They have met it with surprising success as several of the new transformers show. It is up to the builder to make the best use of the manufacturers' efforts and not spoil the result by touches of his own.

Many radio builders think it an advantage to shunt their transformers with condensers or grid leaks. While this practice sometimes helped to improve quality with the old type transformers, with a transformer of good design it generally ruins quality.

A condenser across the primary of the first audio transformer is usually advisable, and may be as large as 0.005 microfarads without affecting the faithfulness of reproduction. Devices across the secondary are particularly harmful. Fig. 112 shows the effect of several sizes of condensers and grid leaks across the secondary. The effect of the

Fig. 111. The effect of plate impedance on the operation of a transformer of high primary impedance. The curves of Fig. 110 and 112 show the importance of making measurements with a resistance in series with the transformer primary. Otherwise an entirely false impression may be conveyed.

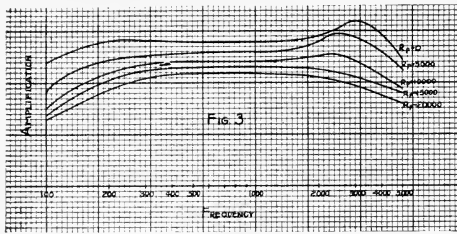

Fig. 111

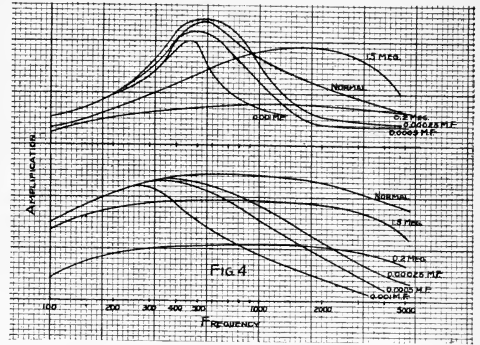

Fig. 112

condensers on transformer No. 1 shown in the upper half of the figure is to make still more marked the peak in the central portion of the curve. The high frequencies are cut off with increasing effectiveness as the size of the condensers is increased. It is interesting to note that at some frequencies resonance effects carry the curves with shunting condensers above the normal curve. The use of grid leaks improves the quality with this poor transformer. With a leak of 1.5 megohms, a curve similar to No. 2 of figure 109 is obtained. This curve is poor but somewhat better than the normal one. When the shunting resistance is reduced to 200,000 ohms a very flat curve is obtained, but the 8:1 transformer gives less amplification than a 2:1.

The effect of shunting condensers across the secondary of transformer No. 4 is similar to that observed in No. 1. The amplification of high frequencies is greatly reduced, with the point at which the curve falls coming farther toward the low frequencies as the condenser size is increased. The improvement in quality gained by shunting the secondary with a resistance is not so marked as with the badly peaked transformer. A great loss of volume is caused by this practice. With the 200,000 ohm resistance across the secondary the amplification is cut approximately in half, with no great improvement in quality.

The radio set can be made to reproduce music as faithfully as the average phonograph, or even more so. If this is to be accomplished the whole amplifying and reproducing system must be laid out with this purpose in view. Good transformers must be used, in the way the manufacturers intended them to be used. Tubes must be properly biased, and not overloaded, and finally, all other precautions are in vain unless a good reproducer is used.

Fig. 112. A group of curves showing the effect of shunting various devices across the transformer secondary. The upper group were taken with a poor transformer, the lower on the newer types.

"A" BATTERY ELIMINATION

Some very elaborate "A" battery eliminators have been devised, a few very complicated. The most complicated method is to use a high voltage of say 400, tapping off a portion of this voltage (40 volts for eight 5 volt tubes in series). It is necessary where several tubes are in series that each tube have the same filament current rating. With an arrangement like this it would be impossible to insert a UX200 tube or UX112 tube in series with several 201A tubes. There is the further disadvantage that if there is an abnormal rise in voltage, not one but all the tubes in series burn out.

There are many "A" power units consisting of a charging unit and battery in one, when in operation no power is actually taken from the battery but the battery is kept in circuit to stabilize the circuit and also to use the capacity of the battery for filtering effect. This is an entirely satisfactory arrangement where there are no objections to giving the battery proper attention occasionally.

Tubes with the filaments operating off alternating current is a good solution of "A" battery elimination and works efficiently on sets having up to seven tubes. In eight and nine tube receivers, the alternating current tubes present obstacles which have not yet been overcome to an extent where the efficiency compares with the same number of storage battery tubes.

"A" eliminators without batteries have been available for some time but only of sufficient capacity to handle a drain of $2\frac{1}{2}$ amperes. For the Silver Ghost and Universal Transoceanic Phantom a total of 3 amperes is required and heretofore a suitable eliminator has not been available. The new unit described herein is fully capable of supplying 6 volts 3 amperes continuously from a regular 110 volt 60 cycle alternating current power line. No battery is used. The power line voltage of 110 volts is stepped down by a transformer to deliver the proper voltage to a full wave dry rectifying unit where it is changed to direct current. This direct current is then passed through a special filter circuit so that the final current is free from any noise or disturbances. This filter circuit requires a condenser of high capacity and if a condenser of ordinary construction was used, the cost of the condenser alone would be approximately one hundred dollars. By using an electrolytic condenser (not battery acid) the cost of the whole unit is reduced so that the complete "A" battery eliminator can be manufactured to retail for less than fifty dollars. There are no acids to test or spill. Distilled water may have to be added to the condenser once or twice a year which is not an objection. Current is taken by this unit only when the receiver is in operation and the current consumption is very low the average

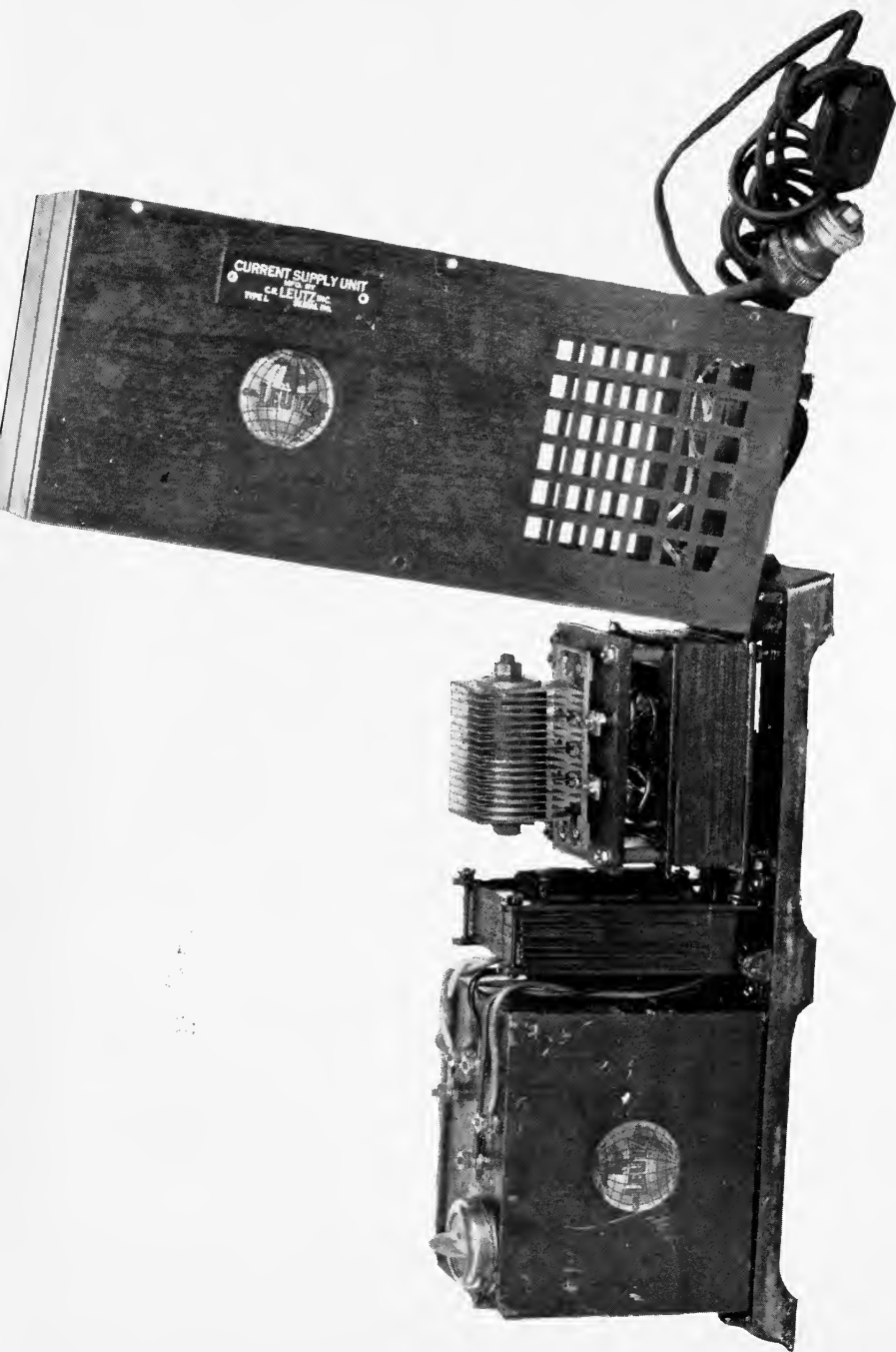

Fig. 112A.
Leutz "A" Current Supply. A complete "A" battery Eliminator having the high capacity of 3 amperes at 6 volts, sufficient for all ordinary receivers up to 10 tubes including a power tube.

cost during operating being about two cents an hour. When this eliminator is connected to an ordinary set, it has an outlet plug for the B battery eliminator so that the switch controls both eliminators simultaneously. When used with the Transoceanic Silver Ghost or Phantom, the single control switch is arranged to operate the entire equipment. The cost is approximately the same as a good storage battery and charger and the "A" battery eliminator has the advantage of more economical operation and far less care.

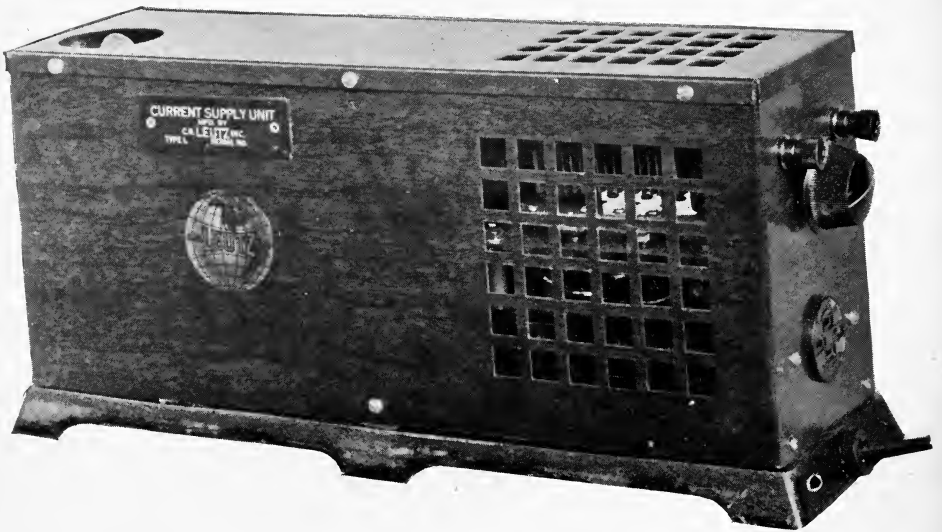

Fig. 112B.

Leutz "A" Current Supply.

Chapter III

RADIO RECEIVERS

A WESTERN ELECTRIC SUPER-HETERODYNE

The Western Electric Type CGR1 Receiver was designed for the U. S. Coast Guard. The double detection (super-heterodyne) type of receiver was decided upon on account of the required sensitivity and selectivity required over the specified wavelength range of 100 to 200 meters (3000 to 1500 kilocycles). The design allows reception of telephone signals, interrupted continuous wave (ICW) signals and in addition the reception of continuous wave telegraph signals. This last feature is possible through the use of a separate tube used as a heterodyne to beat with the intermediate signal frequency. The development of this receiver involved a number of difficult problems on account of the rigid requirements imposed the manufacturers. It had to be sensitive, to give a minimum voltage amplification of 5000. In respect to selectivity, it had to be capable of tuning out signals differing widely from the desired transmitter frequency but capable of receiving signals when the carrier wave did differ from time to time not more than 5 kilocycles from the specified frequency. Due to the possibility of having inexperienced operates for certain watches, the tuning adjustments had to be simple and capable of being locked

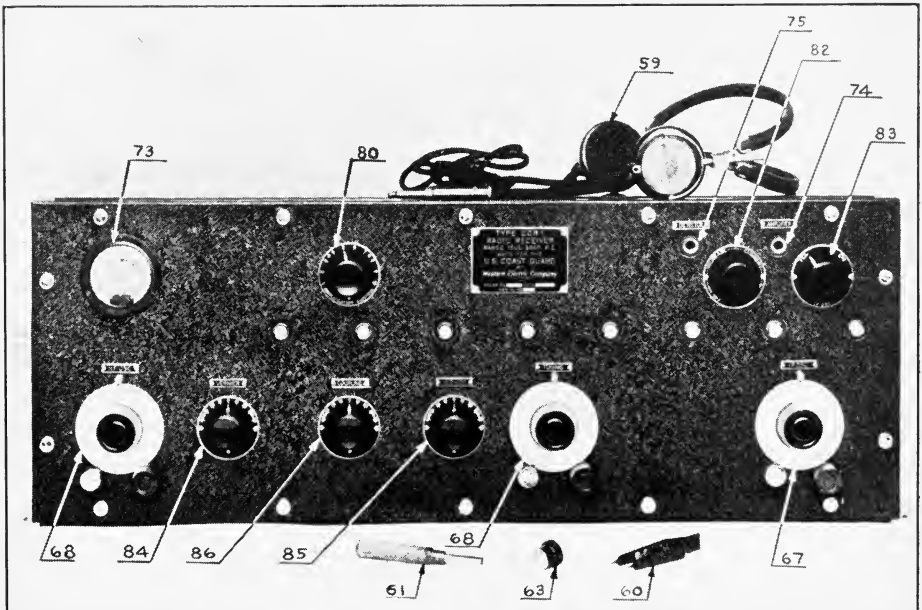

Fig. 113

in position and the set placed in operation by simply turning the filament switch on. Figures 113, 114, 115, and 118 are internal views of this receiver showing the general arrangement of the apparatus. The shielding is complete due to the brass panel and shielded partitions and box shielding.

The complete receiver circuit Figure 116 may be considered as six separate circuits, viz.:

- Radio Frequency Input Circuit
- Radio Frequency Oscillator Circuits
- Modulator or First Detector Circuit
- Intermediate Frequency Amplifier Circuit
- Detector (Second) and Audio Frequency Circuits
- Intermediate Frequency Oscillator Circuit

INTERMEDIATE FREQUENCY CHOICE

It is known that the intermediate frequency selectivity is of no value in differentiating between two signals, the carrier frequencies of which differ by twice the intermediate frequency, therefor a moderately high intermediate frequency was chosen. As the intermediate Frequency is raised, the amplification obtainable is greatly reduced and the regenerative effects due to interstage coupling of all forms is greatly increased. On the other hand if the intermediate frequency is too low, the tuning of the secondary circuit and that of the oscillator will differ by only a small percentage off the carrier frequency, and the tuning of the two circuits will not be independent of each other.

50 kc. was chosen for the intermediate frequency. Satisfactory transformers had been developed for this frequency and were available. Furthermore the required amplification could be obtained at this frequency and the amplifier did not require any stabilizing adjustment in order to prevent a tendency toward internal oscillations.

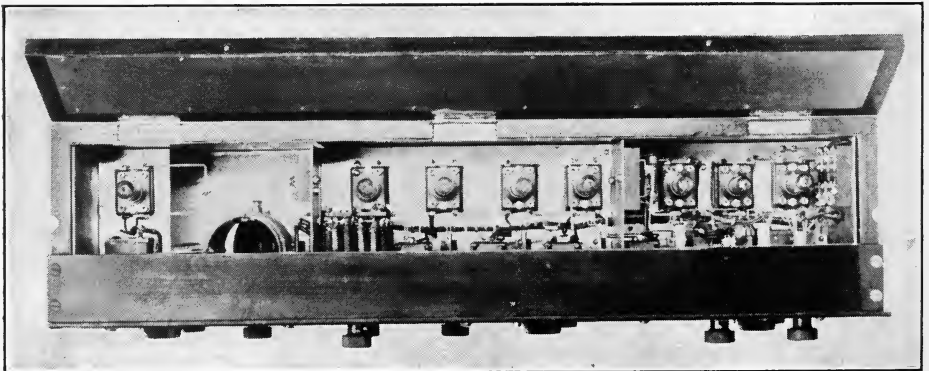

Fig. 114

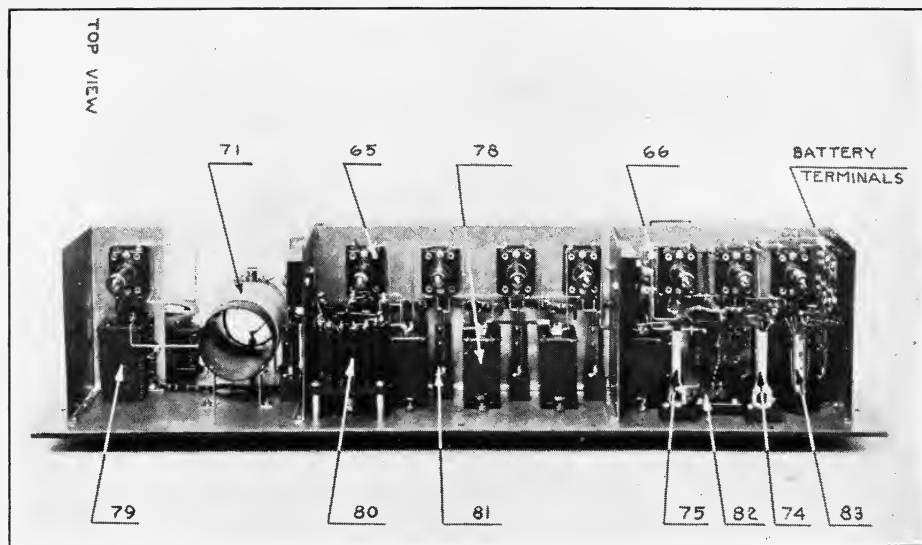

Fig. 115

RADIO FREQUENCY INPUT CIRCUIT

This receiver is designed to operate in connection with an antenna. To eliminate one tuning control, the antenna circuit is not tuned independently. The circuit used to couple the antenna to the input is the simplest possible method as shown in the schematic diagram. Directly between the antenna and ground a small coupling coil is connected, the mutual inductance between this coil and the secondary circuit being adjustable. When the coupling between these two coils is increased the signal strength is increased. However a point is reached when the gain in signal strength stops and instead a decided decrease in selectivity starts in. Accordingly the size of the coupling coil was selected with a view of securing maximum signal strength without greatly impairing the selectivity of the secondary circuit. This exact point of coupling is sometimes referred to a point of critical coupling or the optimum coupling point. The coupling coil is mechanically mounted at the low potential (ground) end of the secondary coil. the capacity coupling between the two coils is then at a minimum as one end of each coil is connected to ground. The secondary coil is wound with bare copper wire spaced by its own diameter on a thin walled tube. The result is a coil of very low radio frequency resistance, actually as low as the best types cellular windings without mechanical supporting dielectrics. The "vernier" adjustment consists of a small coil mounted at the opposite end of

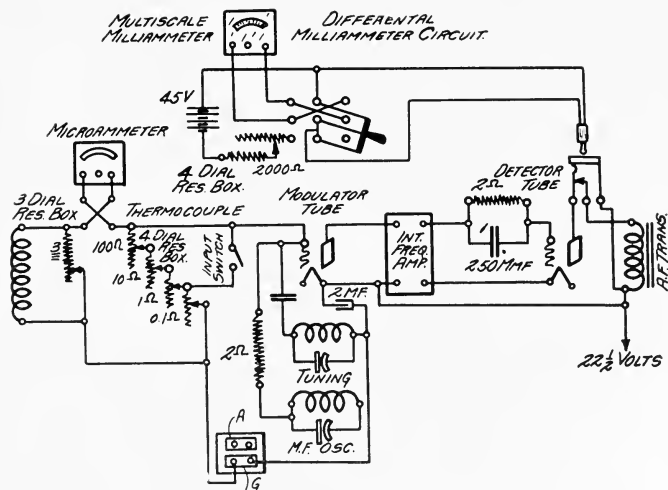

Fig. 117

the secondary coil from the antenna coupling coil, but connected in the low potential end of the tuned circuit in order to have one end of the "vernier" coil at low potential, free from "body capacity." A variable inductance as a "vernier" has many advantages over the use of a separate plate on a variable condenser. In the latter case the capacity of the separate plate may be 1/10 or 1/20 of the total capacity of the condenser, but when the condenser is adjusted to some point near its minimum capacity, the capacity of the "vernier" may be considerably greater than critical. On the other hand with the inductance "vernier" the percentage change in inductance and in the resonant frequency is nearly constant over the entire range of the receiver. The design of the "vernier" allowed a variation equivalent to about 10% of the condenser setting for the major portion of its range. Accordingly the actual tuning adjustment on this type of "vernier" is no more critical at the lower range than at the upper range of the receiver.

RADIO FREQUENCY OSCILLATOR CIRCUIT

The tuned grid inductively coupled oscillator circuit was used so that the tuning condenser is connected across only the grid coil. One side of the condenser is then at filament potential (rotor) and consequently the adjusting hand has no effect on the oscillator circuit. The inductance "vernier" is used in series with the grid coil and is mounted at the high potential end of the coil. The oscillator coils are designed so that the reading of the scale of the oscillator condenser

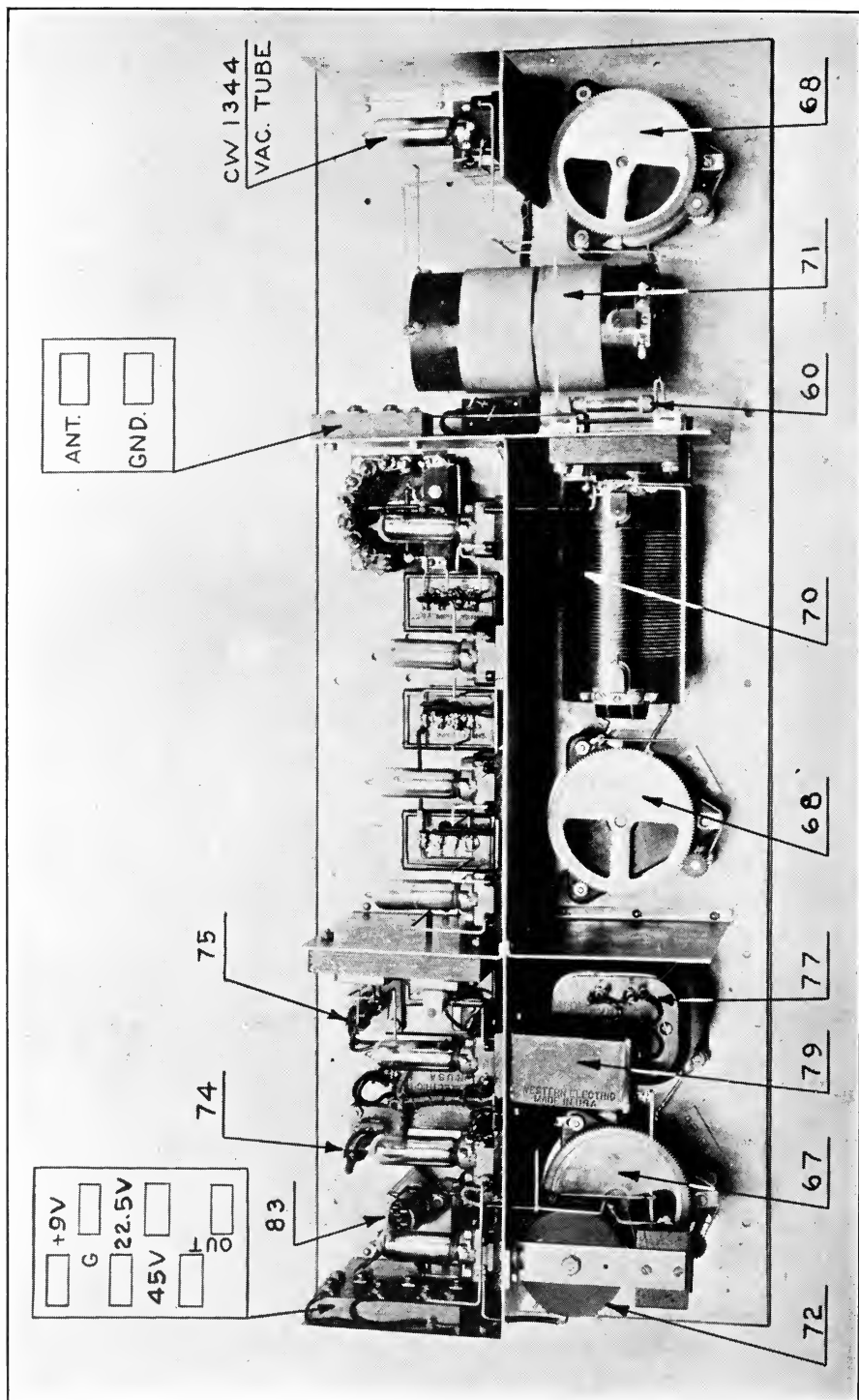

Fig. 118

for a frequency 50 kc below that of the incoming signal is practically the same as the scale reading of the secondary circuit of the receiver over the entire tuning range.

MODULATOR OR FIRST DETECTOR CIRCUIT

The grid condenser and grid leak type of modulator was used in this circuit because it requires a much smaller input on the grid for maximum efficiency than the negative bias type of detector. The circuits used for the frequency changing system consisting of the oscillator and modulator are illustrated in the schematic wiring diagram. The condenser and grid leak combination was used for maximum efficiency, which is obtained with a condenser of 100-micro-microfarads and a 2 megohm resistance leak.

The grid leak is not only a grid leak for the detector tube but also serves as a means of coupling the detector tube to the oscillator. With this circuit the adjustment of the secondary circuit has almost no effect on the frequency of the oscillator except when the secondary circuit is in resonance with the oscillator frequency, which is not the operating condition. The oscillator frequency is carefully shielded from the remaining portion of the receiver in order to prevent any interaction between it and the secondary circuit, other than the coupling desired through the grid leak mentioned before.

FILAMENT CIRCUIT

The vacuum tubes used in each require a filament current of 250 milliamperes ($\frac{1}{4}$ ampere) at approximately 1 volt. When employing a number of tubes of this particular type it is advantageous to connect the filaments in series, so that the grid biasing potentials may be the drop in potential along the filament circuit. In a receiver having high amplification and with the filaments in series, additional problems are presented because of the coupling thus introduced between the grid circuits of the various tubes. This coupling is satisfactorily reduced in this design by the use of a number of high capacity by-pass condensers properly located. The filament circuit is laid out so that the desired grid bias potentials are obtainable with the simplest possible filament circuit.

DETECTOR AND AUDIO FREQUENCY AMPLIFIER CIRCUITS

The second detector is of the grid condenser type. It has been found by careful measurement that the efficiency of the grid leak type of detector when using the W.E. 215A vacuum tube is considerably greater than that of the negative grid bias of detector upto inputs much greater than are likely to be obtained in practice. The

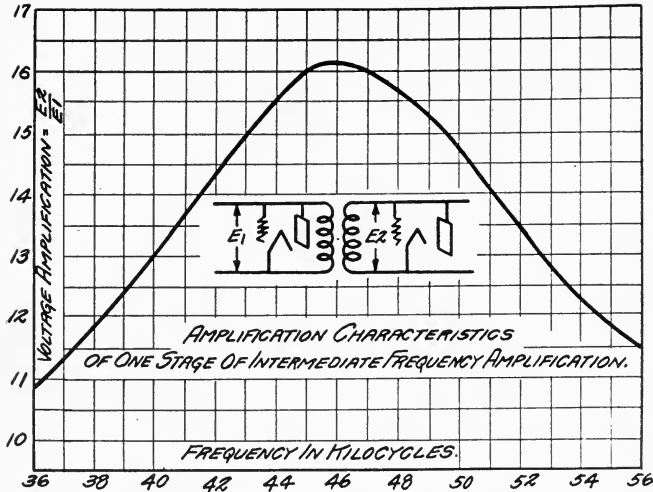

Fig. 119

disadvantage of the grid leak type of detector is that the output level obtainable it is considerably lower than that from the negative grid bias type of detector. When one stage of audio frequency amplification is added, however, the output level obtainable from the receiver is ample for headphone operation. The detector and audio frequency amplifier form a satisfactory working combination as the relative output levels are such that overloading occurs at about the same point in both tubes.

A by-pass condenser of the order of .001 microfarad is provided in the detector plate circuit, in order to keep the output circuit of low impedance to the carrier frequency. This condenser also raises the detector efficiency besides by-passing radio and intermediate frequencies which may otherwise be amplified by the audio frequency circuits and help to cause over-loading of the succeeding tubes. From the standpoint of detector efficiency, a larger condenser could be used to advantage, but it would result in too great an attention of the higher audio frequencies.

INTERMEDIATE FREQUENCY OSCILLATOR

The intermediate frequency oscillator is of the tuned grid inductively coupled type and is so arranged that it may be turned off by means of a switch in the plate supply line. High efficiency in this oscillator is not required. The problem is not one of high output, but to reduce the coupling from this oscillator to the detector so that the detector would not be seriously overloaded. The by-pass condenser connected as shown reduced the input to the second de-

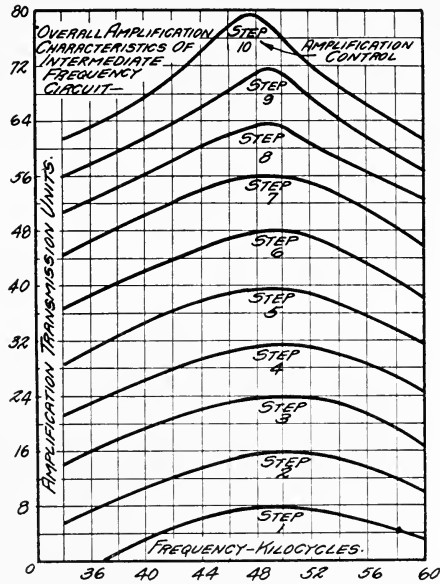

Fig. 120

tector from the intermediate frequency oscillator or about .05 volt at the grid of the second detector, which is the approximate value for the second detector, which is the approximate value for maximum signal strength.

The capacity of the variable condenser was made only a small portion of the total tuning capacity as it was desired to have a frequency adjustment of only four or five thousand cycles.

Having this oscillator adjustable over such a limited range is of value in differentiating between signals from two stations very close together in carrier frequency. The radio frequency adjustments of the receiver may be set for the optimum strength of the desired station and the intermediate frequency oscillator adjusted so that the beat notes of the desired and undesired station may be most advantageously adjusted.

The coupling between the intermediate frequency and radio frequency oscillators is reduced to the lowest possible degree in order that the harmonics of the intermediate frequency oscillator will not beat with the fundamental of the radio frequency oscillator when it is adjusted over its operating range. With the intermediate frequency oscillator turned on, beat notes will occur for only two settings of the high frequency oscillator condenser, corresponding to 50 kc above and below the carrier frequency.

INTERMEDIATE AMPLIFIER

A very satisfactory intermediate radio frequency transformer had been developed prior to the design of this receiver. The frequency characteristic of one of these transformers is shown in Fig. 7. This characteristic of one of these transformers is shown in Fig. 119. Radio frequencies must not be transmitted by the intermediate transformer. It was found that when four of these transformers were used in an intermediate frequency amplifier, the characteristic obtained was quite different from the fourth power of the characteristic of a single transformer. This was expected, because the input impedance of a vacuum tube is a function not only of the grid to filament capacity but also affected by the make-up of its plate circuit. The input impedance of a grid leak detector tube is also very different from the input impedance of an amplifier tube.

A satisfactory overall characteristic was obtained by balancing out some of the interstage coupling capacity. The balancing capacity is not only used to stabilize the amplifier and to reduce any tendency toward internal oscillations, but its proper adjustment determines the shape of the amplifier characteristic. The amplification of the receiver is controlled by means of a potentiometer. The total resistance of this potentiometer is closely related to the value of the balancing capacity. The proper combination of these two values results in the desired characteristic.

The potentiometer gain control shown is adjustable in ten steps, having a voltage amplification ratio between them of approximately 2.5 to 1. The over-all amplification of the receiver for various steps of this amplification control is shown in Fig. 120. The selectivity is greatest when the maximum amplification is used. This is a very desirable characteristic, as when a signal is so weak as to require maximum amplification of the receiver a high degree of selectivity is usually required. The selectivity of the receiver is intentionally made considerably less than might be obtained in order to be able to receive signals when the carrier frequency changes slightly or is not absolutely set by all transmitters.

MEASUREMENT OF THE INTERMEDIATE FREQUENCY AMPLIFIER

For the measurement of the over-all intermediate frequency amplification, the circuit used is shown in Fig. 117. The input resistance R_1 assumes different values in accordance with the intermediate frequency amplification to be measured. The current thru the input resistance is kept constant at 1 milliamperes. For measuring the amplification obtained on the two upper steps of the amplification control,

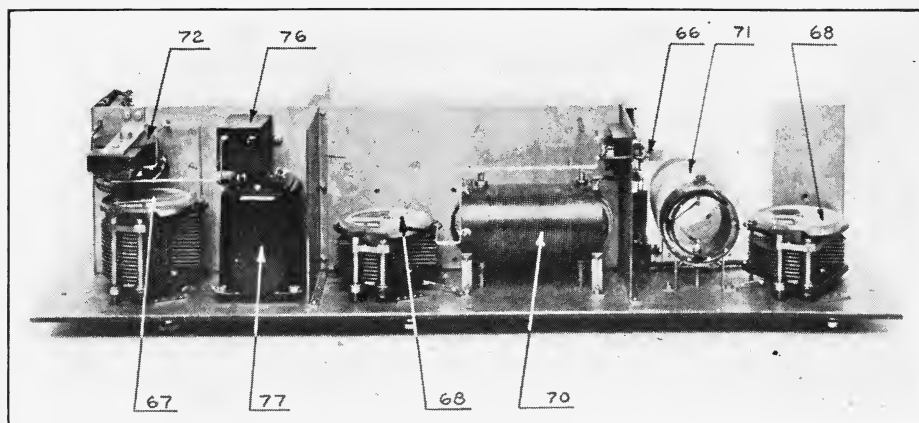

Fig. 121

the input resistance R_1 consist of a short straight piece of high resistance wire having a resistance of 0.1 ohm mounted directly in the base of the short circuiting switch, this being the only practical way eliminating undesirable pick-up. With a voltage amplification of 10,000, this means that 1 milliamperes flowing thru this resistor will give an input of 1 volt to the grid of the second detector. When the amplification is reduced to 2000 or less, resistance boxes may be used for the input resistance provided that precautions are observed to make all leads as short and direct as possible. It is essential that the input voltage to the receiver consist of only the drop across a definitely known resistance and that the current measured by the thermocouple should be the entire current thru this resistance and no other. The second detector, including its condenser and grid leak, is calibrated by connecting it directly across resistance R_1 , which for this purpose consists of a variable resistance box having negligible inductance and capacity at 50 kc. A complete calibration curve of the detector up to a voltage input corresponding to a change in plate current of 200 microamperes is usually made. When measuring the amplification of the receiver, the current through the input resistance is adjusted to the same value of 1 milliamperes and the change in detector plate current noted. This is most conveniently done by the use of a differential meter in which the normal space current of the detector is neutralized by a current from a separate battery flowing through the proper resistance, see Fig. 117. As the amplification is decreased by using the lower steps of the amplification control, the input resistance R_1 is increased so that the input voltage to the grid of the second

detector is of the order of 0.5 to 1.0 volt. In all these measurements it is very essential that the oscillator be thoroughly shielded from the receiver so that with the switch across resistance R 1 closed, no change in plate current of the second detector may be noted when the oscillator is turned off and on, even though the maximum amplification of the receiver is used. This method was used in measuring the frequency characteristic of the receiver.

ARRANGEMENT OF COMPONENT PARTS

Fig. 113 is a front panel view, High Frequency Oscillator Dial (68), and its vernier (84); Secondary Tuning Dial (68) and its vernier (85); Intermediate Oscillator Dial (67). 86 is the Secondary Coupling Adjustment. The 10 step Amplification Control is indicated by (80). The Filament Rheostat is shown at (82) and the Switch for the Intermediate Oscillator at (83). In Fig. 118, at the extreme right hand end is shown the Oscillator tube, Oscillator Variable Condenser and Oscillator Coupler, also the coupling Grid Leak. In the lower center compartment is the Secondary Tuning Condenser (68) and Secondary Inductance (70). Directly above, in the center and upper compartment is the Modulator or First Detector and the three Intermediate Amplifier Tubes and their coupling amplifying transformers. In the lower left compartment is the Variable Tuning Condenser (67) for the Intermediate Oscillator also the Inductance for same and by pass condenser. In the remaining compartment (upper left) the second detector, audio amplifier and intermediate oscillator tubes are arranged. (75) is the jack for Detector alone and (74) the jack giving one stage of audio frequency amplification. (83) is the switch for disconnecting the intermediate frequency oscillator. The same apparatus belonging to the upper partitions is shown in Fig. 114 as a plan view. In Fig. 121 the apparatus on the lower shelves is shown in more detail. The apparatus mounted in the cabinet is shown in Fig. 114 and it will be noted that the entire inside surface of the cabinet is shielded by being lined with sheet metal.

GREBE SYNCHROPHASE SEVEN

Chaos has been practically eliminated through the efficient functioning of the Federal Radio Commission. Once again all local stations are established on channel frequencies where they will not carry a blanket carrier wave over another nearby broadcasting station. In order to bring about this so-called ideal situation the Commission has utilized all of the channels down to the lowest wavelength assigned to broadcasting. Had this been done two or three years ago there would not be the general unfavorable attitude toward the low wave lengths that exists today. Unfortunately most of the earlier types of receiving sets did not properly take care of low wavelengths because of their tendency toward excessively broad tuning and oscillations and the general unfavorable attitude toward the low waves on the part of the broadcasters permitted manufacturers to escape without criticism, even if their sets did not tune below 250 meters. There is still room for improvement in the operation of receiving sets on the lower wavelengths, as many receivers tune broadly and tend to go into oscillation on wavelengths below 300 meters.

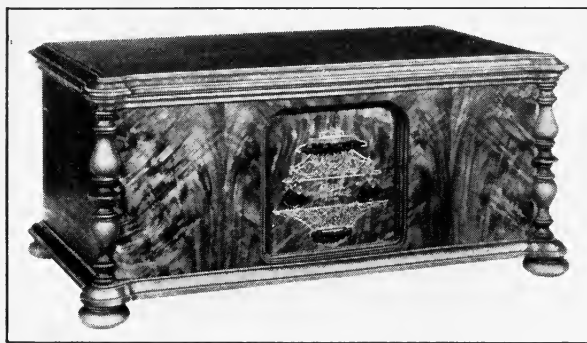

Grebe
Synchronphase.

Fig. 122

In the design and construction of the Grebe Synchronphase Seven, much time was devoted to perfecting a highly efficient short wave reception system.

Principally by the combination of ingeniously devised tube isolating circuits and fieldless, space-wound, binocular coils, the following improvements have been achieved:—

1. Greater and more uniform response and selectivity on both the high and low wavelengths within the broadcast band.
2. Nullification of all tendency toward oscillation.
3. Removal of detuning effects due to differences in vacuum tube characteristics of any one type.

WIRING DIAGRAM
FOR
GREBE SYNCHROPHASE SEVEN
 A.H. GREBE & CO., INC. RICHMOND HILL, N.Y.

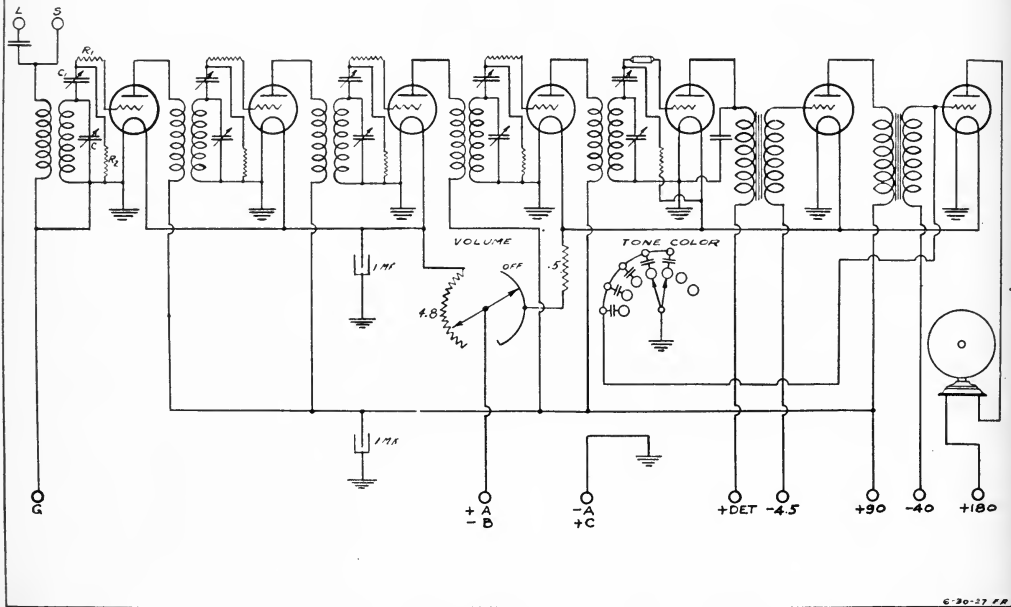

Fig. 123

4. Liberal tuning leeway on dial below and above broadcasting range.

5. Elimination of broad tuning effects in low wavelengths.

6. Accurate matching of tuned stages on all broadcast wavelengths.

A feature, which contributes largely to the superior performance of the set on the longer wavelengths is the use of a special insulated Litz strand for the binocular coil windings. This type of wire has a peculiar property of producing greater signal strength than solid wire on the longer broadcast wavelengths.

In addition to the effect on longer wavelengths, space winding this wire produces a marked increase in selectivity on the shorter wavelengths, where selectivity is particularly desirable.

The fieldless properties of the binocular coils overcome feedback between the tuned stages and prevent signals from entering the detector except through the first radio frequency stage.

Although the individual units comprising the receiver are not shielded separately, the entire interior of the set is shielded. Aluminum plate is used to line the interior of the wooden cabinet, while an aluminum deck serves as the lower shield. On this deck all of the apparatus is mounted, each unit having its own terminals projecting through the deck, so that not a single wire can be seen above it. In this manner the wiring is completely shielded from its associated tuning elements and the problems of troublesome feedback is eliminated. The wiring has been reduced to extreme simplicity, so that a single photograph of the under side of the deck plainly shows each individual connection.

The circuit used in the Synchronphase Seven is one which is the outcome of the many years' experience of the designers.

Let us look at it. Elsewhere is shown the full schematic wiring diagram, together with all the constants for the coils, condensers and resistances.

Close scrutiny of this circuit reveals that we have four stages of tuned radio frequency amplification, a detector and two stages of audio frequency amplification, the last audio stage being designed for use with a 171 power amplifier tube.

In all we have five tuned stages, requiring five variable condensers.

These five individual variable condensers, horizontally mounted and rigidly secured in place, are driven in unison by a three point tuning

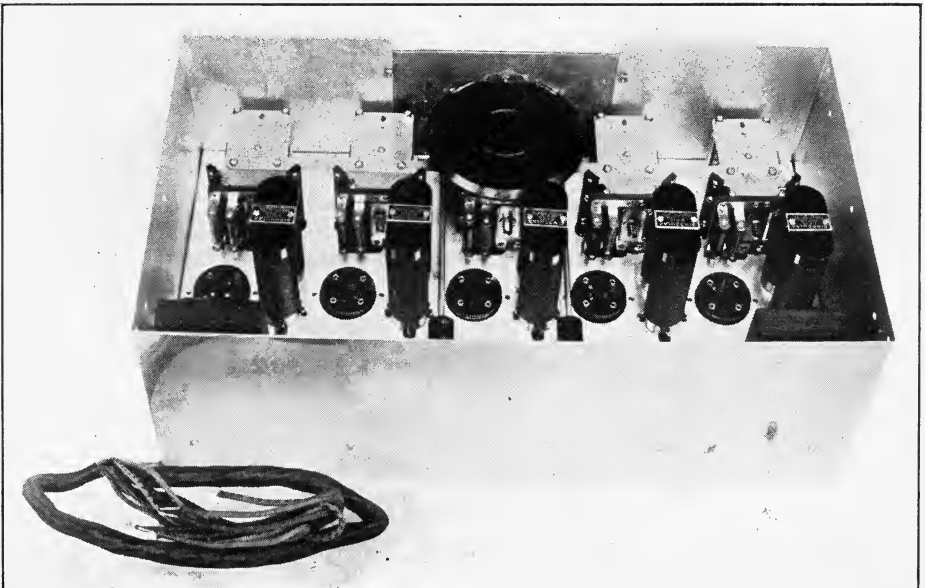

Fig. 124. Grebe Synchronphase.

drive device which is connected with the single dial and vernier on the front of the marquetry panel.

The rigidity of the tuning condenser assembly insures the permanency of the accurate factory adjustment.

These variable condensers have a maximum capacity of 275 micro-microfarads.

The letters L and L1 indicate the binocular coils in the schematic diagram shown herewith. L1 is the primary coil, which is the same in each stage throughout the receiver. Each primary coil consists of thirty-five turns of No. 36 wire. The secondary coils are divided into two halves, each having 122 turns of 10X38 Litz wires on it.

In the grid circuits of the tuned stages R, R1, and C1 comprises the newest Grebe feature, the tube isolating circuits.

It is through the employment of these tube isolating circuits that greater selectivity, more uniform signal response and better reception on the low wavelengths are obtained. Also nullification of excess oscillation.

Briefly, the tube isolating circuit consists of an adjustable condenser having a maximum capacity of 100 micromicrofarads, a resistance R, having a resistance of between three and eight megohms, and a second resistance, R1 of 425 ohms.

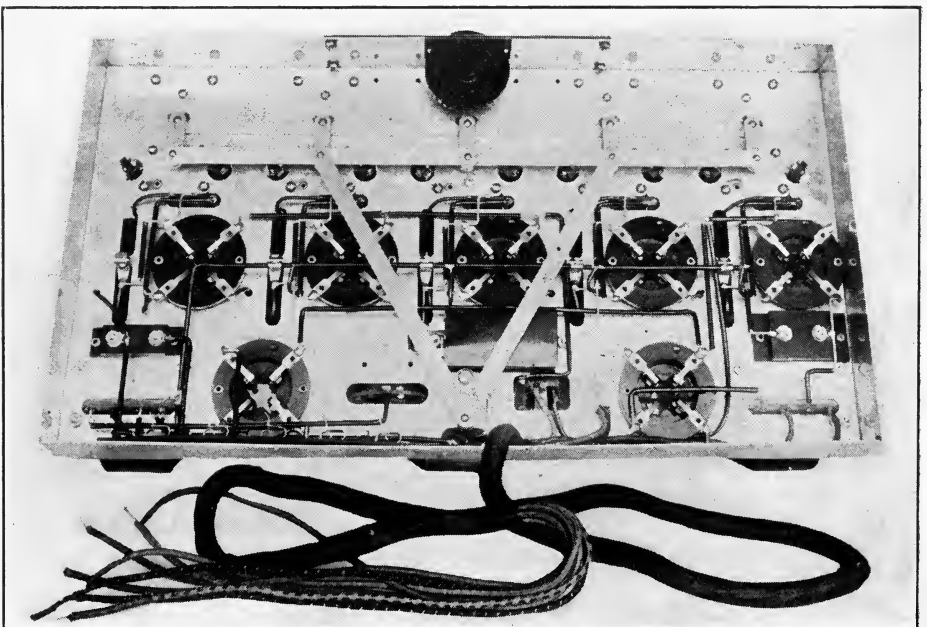

Fig. 125. Grebe Synchronphase.

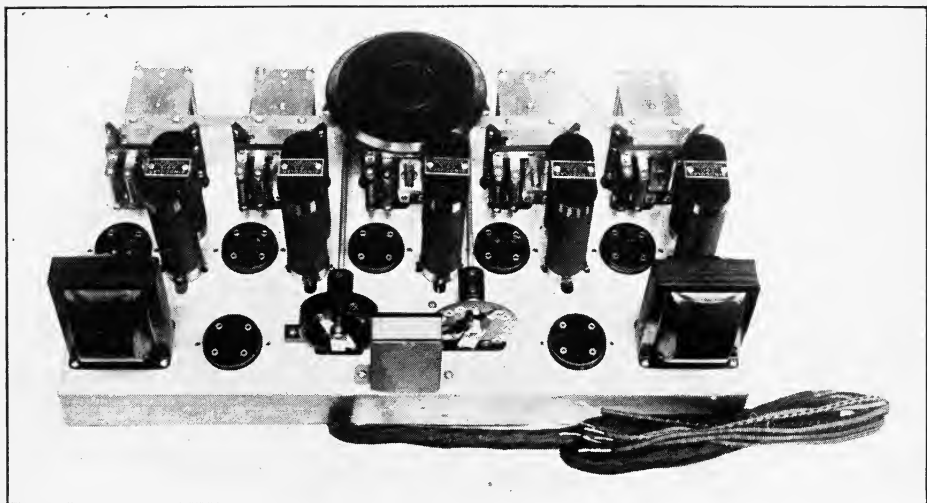

Fig. 126. Grebe Synchronphase.

All the negative filament terminals are connected to the aluminum deck, this acting as a ground and master connector. Where such connections are made they are indicated by the conventional "ground symbol" in the accompanying schematic diagram. Thus the "A" minus terminal goes directly to the shield (deck) and to a small by-pass condenser.

In the detector stage it is slightly different (i.e., the tube isolating circuits) in that we have one less resistance and the remaining one is connected between the grid and the filament plus. The adjustable capacity remains the same maximum capacity as in previous stages and stays in the same place in the circuit.

Going further on in the circuit we find another exclusive Grebe feature, the "colortone," which device permits the listener to modify the frequency characteristics of the audio system to conform with individual preference and offers a ready means for correcting deficiencies in reception due either to a preponderance of high or low frequencies in the transmission of a broadcast station itself.

By the use of specially designed large core audio frequency transformers the audio system used in the Synchronphase Seven meets all requirements as to volume and quality. It delivers a maximum of uniform undistorted power to the loud speaker, operating admirably with modern types of cone speakers.

This receiver is adaptable to use with either a short or long antenna, having facilities in the antenna circuit in the form of a direct connection

and a series condenser connection for use with either at will.

One of the epochal advances in radio receiver control is manifest in the method employed by the designers of the Synchronphase Seven in operating five variable condensers through one dial and a tangent vernier.

The method, which is usual, utilizes a three point driving device which controls through its mainshaft the five variable condensers simultaneously.

Perfect control and synchronization is had throughout the entire wavelength range by the final factory adjustment of the various tube isolating capacities.

Operating on six 201 A type vacuum tubes and one type 171 power amplifier tube, the Synchronphase Seven is suited for operation with a standard "B" and "C" battery eliminator or Socket Power.

Voltages varying from $22\frac{1}{2}$ to 180 volts are necessary for operation of the receiver. Ninety volts is required for use on the plates of the four radio frequency stages, $22\frac{1}{2}$ for the detector tube and 180 for the power tube. The ninety volt tap type that supplies the radio frequency stages also feeds the same potential to the plate of the first audio frequency amplifier tube.

A strikingly beautiful feature of the set is the French Marquetry panel through which the dial and vernier project. The appearance is that of old French Marquetry, in which designs are artistically worked out in metal and inlaid in a beautifully figured walnut panel.

This is the Renaissance of Marquetry, a new art in America. The design of the Marquetry panel in the Synchronphase Seven is an exceptionally fine example of what may be done to beautify radio receiving sets. The panel is genuine butt walnut with the design wrought in bronze.

The cabinet is two-tone walnut and mahogany, the walnut face being of select figure butt walnut, blending with the spirit of the Marquetry panel.

UNIVERSAL TRANSOCEANIC SILVER GHOST MODEL

Since 1921 the writer has had from year to year, undoubtedly the most advanced and powerful radio broadcast receivers possible to construct. In 1922 it was the ten-tube Model L Super-Heterodyne, at that time the nearest competitors were three-tube regenerative receivers. Further progress was made from year to year, the Model C, C-7 and C-10 Super-Heterodynes being developed since that time. The C-10 was developed in 1924 and at that time was without any question the finest broadcast radio receiver obtainable.

Now that broadcasting conditions have changed so differently in the past few years, the problem was to design the most powerful radio broadcast receiver possible, without any limitations. Due to patent limitations it was impossible to use the Super-Heterodyne system and accordingly the problem was seemingly impossible. However, by going to a radical form of construction and design, the Silver Ghost model was developed. It is not a personal opinion that the Silver Ghost is the finest broadcast receiver that one could design and construct, but it is the opinion of every Silver Ghost owner. Silver Ghosts are located in several foreign countries as well as in all corners of the United States. The owners, all experienced experimenters who demand the best, agree that the Silver Ghost is the present day ultimate in radio receivers and undoubtedly will continue to be for quite some time.

The Silver Ghost has the maximum possible total amplification that it is possible to effectively use and accordingly has maximum receiving range. Accordingly, if the signal to be received is stronger than the "static level," it can be received regardless of the distances involved. However, if the signal is only equal or less than the "static level," reception will be limited. This condition is shown diagrammatically in Fig. 58.

Due to the tremendous amount of amplification available it is usually found that weak distant signals can be brought up to the same volume as a local station. Naturally when using this amount of amplification, the received signal will be accompanied by some static disturbances, the exact amount depending upon weather conditions and geographical location of the receiver.

The selectivity is the maximum possible to use without detracting from the musical reproduction. Distant stations separated only by 10

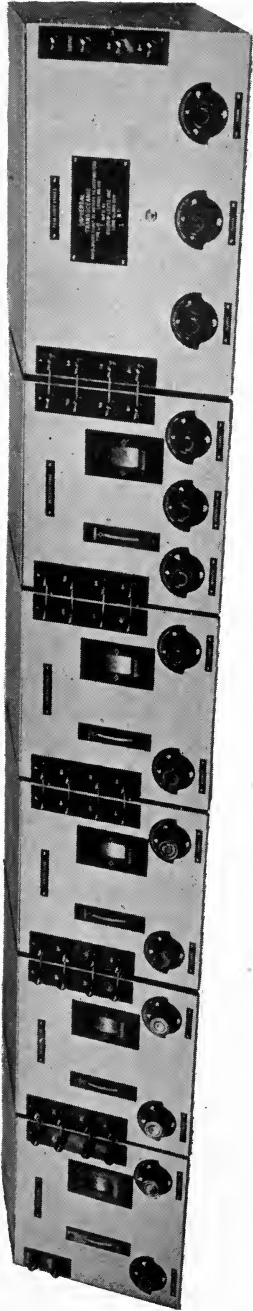

Fig. 126
Universal Transoceanic Silver Ghost Model.



Fig. 127
Antenna Unit.



Fig. 128
Detector Unit.

kilocycles from local stations can be received without any trace of reception from the local signal. As the receiver is non-regenerative and has no oscillator there is an absolute freedom from "beat" (audible oscillations) whistles caused by carrier waves and local oscillation found in some receivers.

Special attention has been given throughout the design to enable nearly perfect electrical reproduction of the received musical programs. These design details are described further on in this chapter.

Unlike an ordinary receiver, the wave length range is not confined to the ordinary broadcast wave length band. In addition to tuning from 200 to 560 meters, the wavelength range can be extended down to 35 meters and up to 3600 meters with standard available interchangeable radio frequency transformers. By the use of special experimental equipment the owner can also receive signals as low as 15 meters and as high as 24,000 meters, which practically covers all the wavelengths used all over the world for all purposes. The interchangeable transformers can be quickly changed without the use of any tools.

The accompanying illustration shows the complete Silver Ghost receiver of six units. These six units are divided as follows: First Tuned R. F. Stage, Second Tuned R. F. Stage, Third Tuned R. F. Stage, Fourth Tuned R. F. Stage, Detector, Four Audio Stages. Each of these six units are completely shielded from each other and the shields do not touch each other. Even the condenser shafts do not touch electrically, being insulated by the universal joints. A separate plate supply is provided for each of the six units. The plate supplies (batteries) are contained within the units and therefore the plate supply batteries of one stage are also shielded from the plate batteries of the adjoining stages. The distance from the Tuned Radio Frequency Transformers to any part of the shield or other internal parts is so great that there is practically no absorption or losses due to shielding. This absolute freedom from shielding losses is a decided contrast to the serious shielding losses in most of the present day receiver designs where shields have been applied with only the single thought of isolating the transformer fields.

The variable condensers are of special design. The stator plates are at an unusually large distance from the condenser end plates, which provides the condenser with a very low minimum capacity. The stator insulators are in the very weakest part of the field, the result being a negligible amount of loss. The rotor plates are of brass, all the plates soldered together. The stator is of similar construction. The shaft is of steel, practically the only piece of steel in the entire receiver design

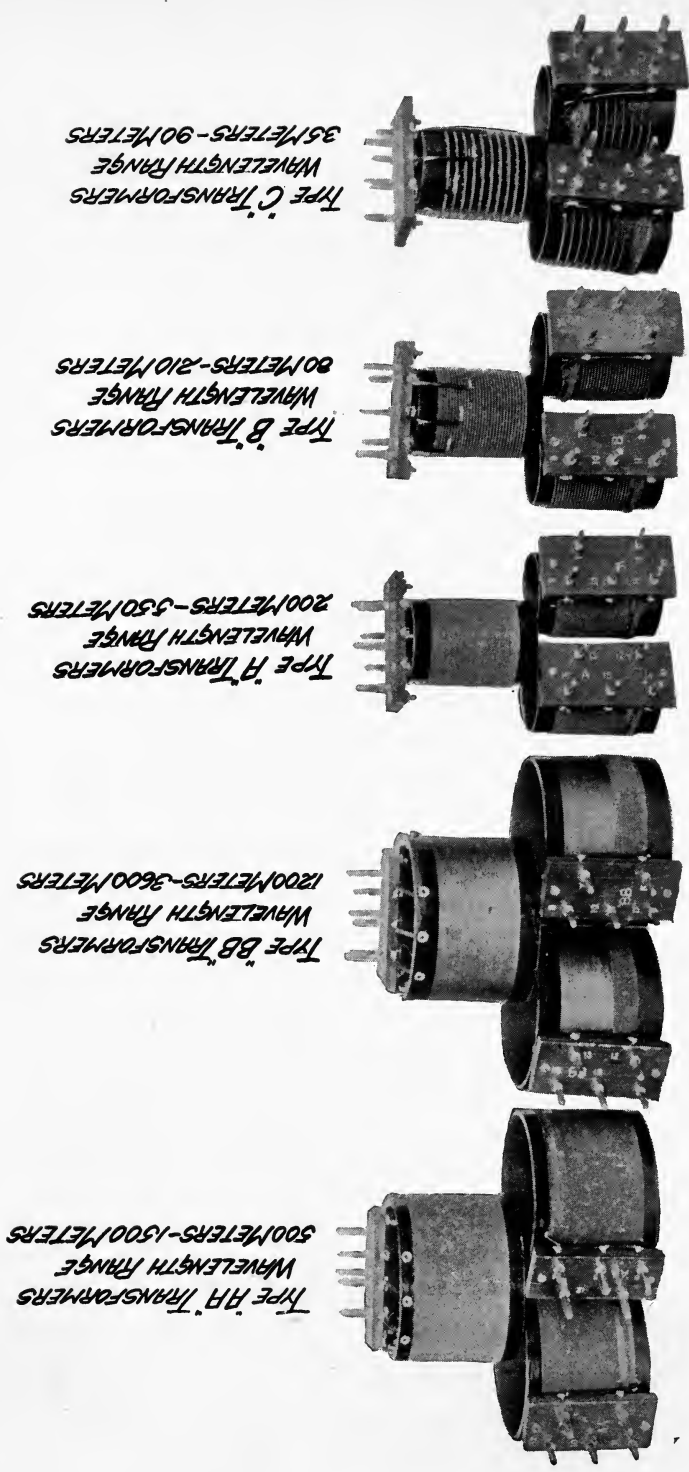

Fig. 129

Interchangeable Tuned Radio Frequency Transformers for the Universal Transoceanic Silver Ghost.

(excepting transformer laminations). At each end of the condenser shaft a flexible universal joint is provided. A short steel shaft connects each two universal joints. This double universal joint between each two condensers allows perfectly free movement of the tuning controls when all controls are connected together for simultaneous control. The universal joints are entirely free from any backlash. Each universal joint is provided with an adjustment, regulated with an ordinary screw driver, so that the universal joints can be brought into play for simultaneous control or disconnected for individual control in a few moments.

The shape of the condenser plates is not straight line frequency or straight line wavelength. It is a very desirable combination of the two which provides the most satisfactory separation of wavelengths on the indicator drums. The condenser end plates, mounting brackets and indicator drum are all made of aluminum.

The Indicator Drum is provided with an Indicator Dial with graduations from 0 to 100 equally divided over half of the circumference. It is impossible to graduate this dial directly in wavelengths or frequencies as the dial has to serve for five or more sets of calibrations. The tuning control and indicating drum are widely separated so that the operator's hand will not interfere with the reading of the calibrations.

Each Unit has binding posts on the upper half of the front panel at each side, allowing one unit to be coupled to the adjoining unit and also allowing the filament supply to be fed through the entire six units. These connections are the only electrical connections between the different units. The binding posts are well insulated on engraved Bakelite plates. The first unit has binding posts to the left for the antenna and ground and if desired also for a loop. The binding posts to the right consist of the radio frequency output posts, Plate and Plate Battery "B" positive, and two filament leads, six volts positive and minus. These posts repeat from one unit to another down to the Four Stage Audio unit.

In the Four Audio Stage Unit there are provided two posts for the six volts battery input, pin jacks for the output or loud speaker, and a cord and plug for the alternating current supply to the audio amplifier B and C eliminator. In the case of the battery operated Silver Ghost the audio plate batteries are placed in the audio case, there being room for 180 volts of heavy duty B batteries for this purpose. The battery operated audio unit is only recommended for installation at points where alternating current is not available.

A single Control Switch controls all operations. This is a special toggle switch having eight contacts and two switch blades which control two circuits on the ON position and one circuit on the OFF position. In the ON position the following circuits function:

1. 110 volts 60 cycles alternating current is fed to the Power Transformer for the rectifier system.
2. The Red Pilot Lamp is lit, indicating the receiver is in operation.
3. The Rectifier tube filament is heated by $7\frac{1}{2}$ volts alternating current.
4. The Power Amplifier Tube filament is heated by $7\frac{1}{2}$ volts a. c.
5. Six volts direct battery current is fed to the other eight tubes.
6. The Power Amplifier Plate is fed 400 volts direct current.
7. The first three audio amplifier tube plates are fed 180 volts d. c.
8. The Power Amplifier Grid is fed a bias of 35 volts direct current.
9. Plate current starts to flow in all the tubes.
10. The Plate current taken by the four audio tubes is indicated by the Millimeter in the four audio stage unit.
11. Any of the direct current A, B or C voltages can be read on the multiple voltmeter except the radio frequency amplifiers B and C.

In the OFF position, all the above conditions are stopped from operating and the incoming alternating current supply of 110 volts 60 cycles is diverted to an outlet in the rear of the audio case. The battery charger is permanently connected in this outlet, and the battery charging leads permanently connected to the six-volt battery. In view of this, as soon as the receiver is turned OFF, the battery is automatically placed on charge.

Returning to the radio frequency end, the radio frequency transformer is provided with an elaborate system of having the antenna coupled to it, this being necessary to secure the proper degree of coupling and consequently selectivity over the wide wavelength range covered. First there is a series antenna condenser which can be cut in or out of circuit by a small short circuiting switch. The capacity of this condenser is .0001 MF., the antenna is really another condenser and practically in every instance much larger in capacity. When two unequal condensers are in series, the resultant capacity is always less than the smallest condenser. Accordingly, when using a large antenna system which may be especially efficient for 300 to 600 meters without a series condenser, this same antenna can be made equally efficient for 100 to 350 meters by simply throwing this series condenser in circuit. Supplementing this condenser is a variable switch having three points, 1, 2, and 3, which provide different degrees of coupling from the antenna to the first radio frequency transformer. Point 1 gives maximum selectivity and minimum signal transfer, point 3 just the opposite and 2 a condition between. The antenna is directly and not inductively connected to the first radio frequency transformer.

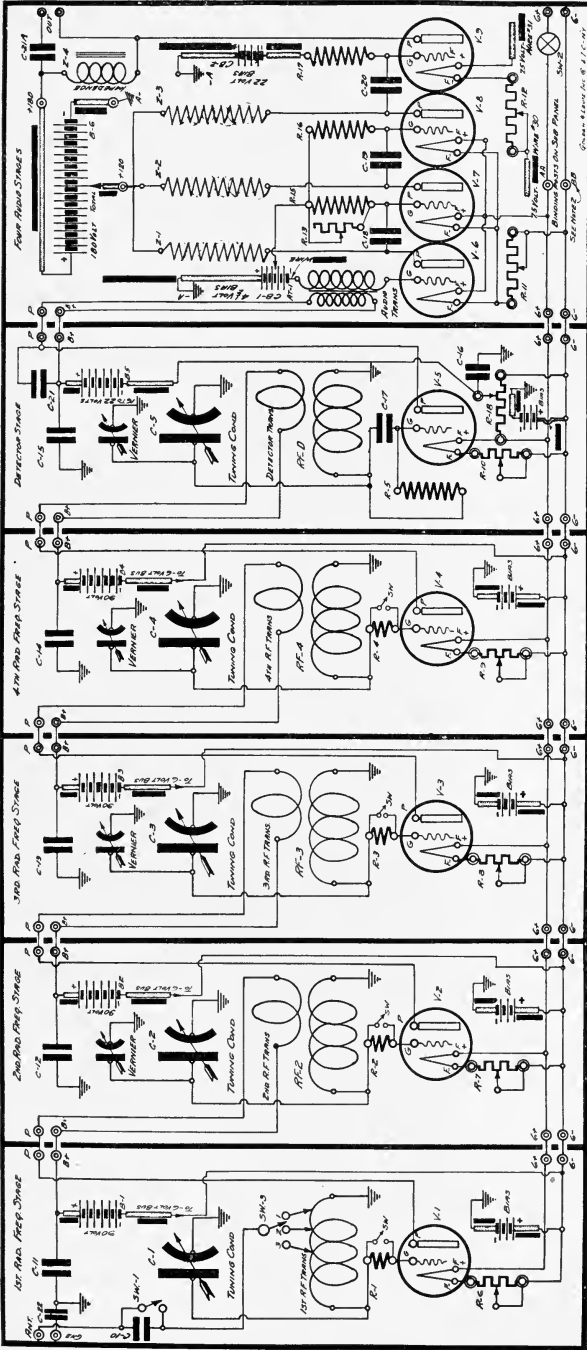

Fig. 130
Schematic Wiring Diagram Transoceanic Silver Ghost.

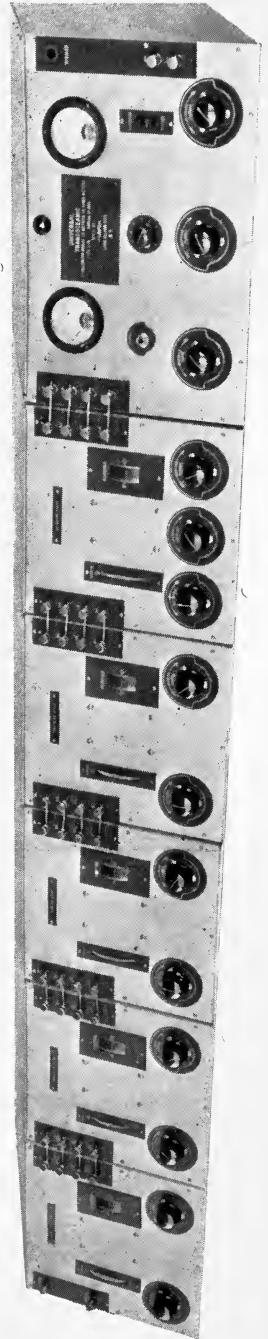

Fig. 130A
Transoceanic Silver Ghost with Built-in Power Audio System.

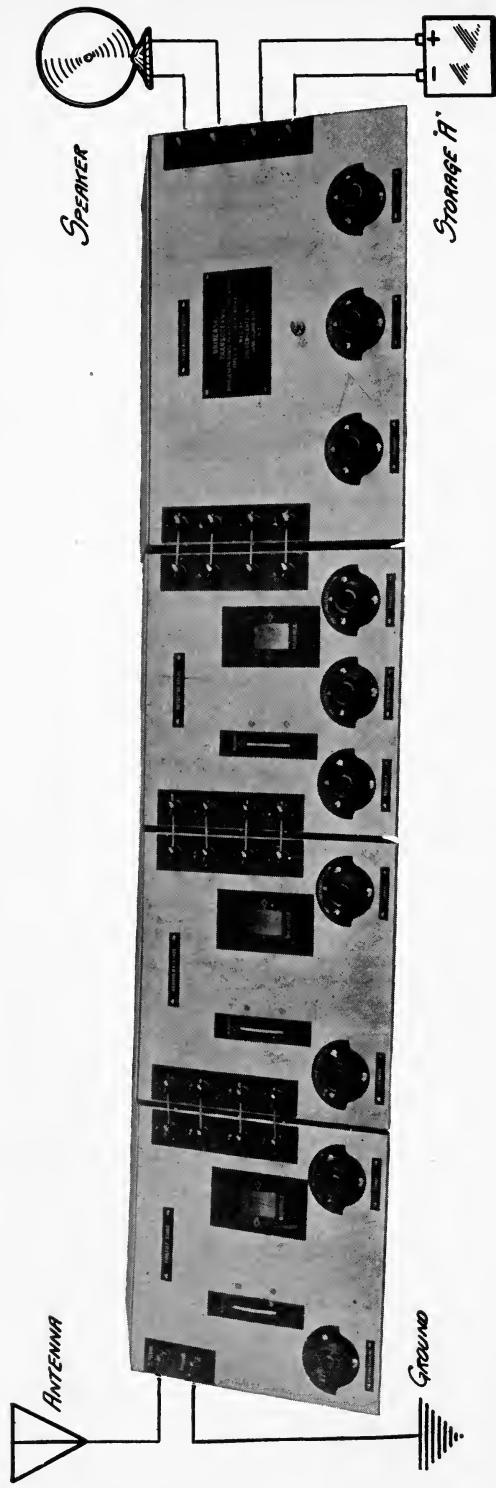

Fig. 131

FOUR UNIT SILVER GHOST.

Consisting of two tuned radio frequency stages, detector unit and four audio stage unit. The third and fourth extra radio frequency stages can be added any time in the future. The audio unit can also be obtained without the B-C power supply. An "A" current supply is also available which supplies 6 volts 3 amperes, the correct amount for the Silver Ghost.

The radio frequency transformers are of a very efficient design. The secondaries are wound, each turn spaced from the other by machine, on a simple bakelite tube. The length of this tube is $1\frac{1}{2}$ times the diameter which is the best proportion for this wavelength range of 200 to 560 meters. Enamel covered wire is never used in a good radio frequency transformer due to the high distributed capacity and losses due to the high dielectric coefficient of the enamel used. They are usually white silk or cotton insulated and treated with a clear varnish which does not introduce losses in the inductances. The coils are never varnished until the moisture has been completely baked out. The primary is only separated from the secondary by a thin piece of insulating paper. The primary turns are usually wound close together and bunched at the filament end of the secondary winding, this construction allowing the maximum possible amplification to be obtained with maximum stability of operation.

Any tendency for the Radio Frequency Amplifier to oscillate is counteracted by a series grid resistor for each tuned radio frequency stage. These resistors have a value of 750 ohms and have some distributed capacity. At 200 to 560 meters the distributed capacity does not enter into consideration. At still lower wavelength than 200 meters these series resistors are not required and may be shorted out of the circuit with a small knife switch provided for each one. The design of the radio frequency transformers also includes features that provide a very stable amplifier, efficient over a very wide wavelength range and free from oscillations, one of these features is that the plate returns are wound with special high pressure resistance wire. The radio frequency transformers, as shown in the cuts, are mounted on interchangeable plug contact bases which fit into suitable plug sockets. This form of construction allows the testing engineer to try several radio frequency transformers in each stage to determine if they compare satisfactorily with a standard, this being impossible in an ordinary receiver. Furthermore each transformer can receive the "individual touch," the engineer can constantly change to the best possible transformer for that particular receiver. Even though every individual part is made to exact specifications there are variations in manufacture which require careful individual attention for maximum results. A suitable comparison is a production of automobile engines, all the parts of each are made to a small fraction of an inch, yet under block test they will vary in maximum horsepower from 5 to 10% or even more. Each engine, if desired, could be adjusted to come up to a standard, but this is not necessary for automobiles of the lower price class. but a severe series of tests and comparisons with standards are carried out by one of the manufacturers of

very high priced cars. The final tests to a Silver Ghost may be well compared with the tests of a very high priced car.

Even before the individual parts of the receiver are assembled, the following tests are made:

1. Transformer (audio) Coils tested for short circuited turns and proper turns. Same tests to Impedance Coils.
2. Assembled audio transformers tested for Amplification Curve and Constants, not "hanging loose" but as actually used in service with direct as well as audio currents flowing.
3. Variable Condensers tested for losses, and for uniform variation in capacity throughout the scale so that four can be used in exact mechanical and electrical synchronism.
4. Power Transformer tested for proper alternating current output without excessive input consumption.
5. Eliminator Filter Condensers tested for breakdowns and for losses and proper capacity.
6. All small fixed condensers tested for capacity, loss and proper breakdown test.
7. All rheostats tested for proper resistance and smooth action without sparking or noise.
8. Resistors tested for proper capacity and current carrying ratings without overdue heating.

After complete assembly the audio unit is tested separately for undistorted musical reproduction with the maximum amplification required. This is tested independently of any radio receiver, the incoming signal being a variable source of audio oscillations from 60 cycles to inaudibility. Changing this variable source of audio oscillations, the frequency range of any musical instrument can be reproduced and the reproduction as given by the loud speaker noted, or if desired, measured.

The amplification of each radio frequency stage is measured individually and the efficiency of the detector unit noted. The entire radio frequency amplifier is then tested, together with the Detector Unit and Audio Amplifier for wavelength range. The wavelength ranges are as follows:

Standard A Transformers.....	200 to 560 meters
" B " 	80 to 210 "
" C " 	35 to 90 "
" AA " 	500 to 1500 "
" BB " 	1200 to 3600 "

It will be noted from the above that there is a liberal overlap between the different sets of transformers. For example it is possible to tune in 550 meters on either the AA or A Transformers. This overlap

is provided as usually a variable condenser is very inefficient at the extreme end of the scale, first five or ten divisions.

With the antenna disconnected it is almost impossible to tune in any signals at all due to the complete shielding. Using an antenna only six inches long, connected to the antenna post, tremendous loud signals can be received from local stations. Using an antenna only ten feet long (indoor) loud speaker signals can be obtained over a distance of 100 miles, which gives a good idea of the extreme sensitivity of the radio frequency amplifier.

When the controls are to be connected together for simultaneous operation it is desirable to leave the antenna control independent on account of changing the antenna series switch or coupling switch which would change this control in relation to the others. The remaining four controls can be connected together if desired for the A, AA or BB transformers. These four dials cannot be set to the same dial graduation due to the variations in tube capacities. The proper method is to tune in a signal around 400 meters which will be near 50 on the dial or about the center of the condenser scale. By tuning the condensers for maximum response, it will be known that the four condensers are in exact resonance for that wavelength. The condensers can then be set at that point, wherever it may be.

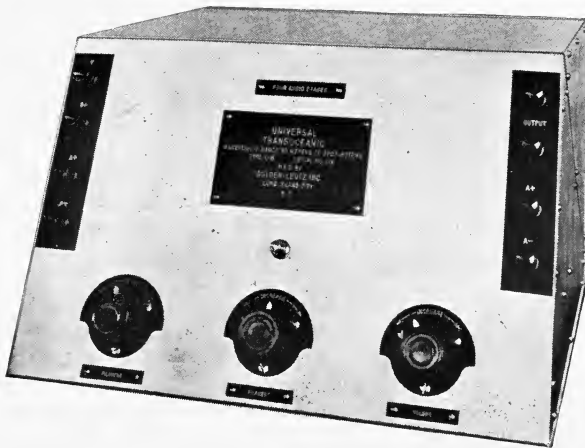

Fig. 132

4 Stage Audio Unit
without Meters or Built-in
"B-C" Current Supply.



Fig. 133

Four Stage Audio Unite with Built-in B-C Current Supply for Silver Ghost.

The operation of the four condensers simultaneously can be checked over the entire wavelength by comparing the calibrations obtained with the earlier calibrations obtained with single control. While the operation of five tuning controls seems a hopeless situation the actual fact is that practically all the owners prefer to use individual dial control, because after the "knack" of individual tuning is obtained, very fine results can be obtained. The whole secret of success in tuning five dials is to keep the five dials each in resonance no matter what wavelength the dials may be tuned to. It is obvious that if the operator can do this he can start at the bottom of the scale and continue right up to the top and during these operations will tune in every station in range. As weak signals will require more amplification than a strong signal for the same response, it is necessary for the operator to keep the amplifier power at a stage where weak signals will not be passed by unheard.

With the five dials in exact resonance, and the amplifier sensitivity at a fairly high point, a soft crackling of static will be heard in the loud speaker. When the one or more dials are out of resonance, the crackling of static ceases. When the operator is able to recognize this condition of resonance, most excellent results will be obtained; on the other hand an inexperienced operator just fumbling with the dials with no system will only receive the strong signals.

With a strong signal properly tuned in with all dials in resonance to the incoming signal, one of the dials may be moved over a fairly wide division of the dial without any noticeable decrease in signal strength. This is not true when receiving a very weak signal. This is not an indication of poor selectivity. To judge selectivity ALL the dials must be changed from one wavelength to another wavelength and still kept in exact resonance.

The adjustment of the detector tube is very important in receiving great distances. For the very best results a UX200 or CX300 detector should be used. This tube, instead of having a hard vacuum, has a quantity of gas left in the tube during the evacuating process. By properly adjusting the tube filament and tube plate voltage this gas is brought into play during the rectification process and unusual sensitivity obtained. This increased sensitivity is particularly noticeable when using such a detector in connection with a three or four stage audio frequency amplifier, the gain being amplified that much more. The UX200 or CX300 detectors do not show any improvements in ordinary receivers that are not specially designed for use with this detector. In the detector unit, a filament rheostat is provided to regulate the filament current and a Potentiometer across the A battery and connected to the detector plate battery return regulates the detector plate voltage by add-

ing or subtracting part of the A voltage to the fixed B voltage. This adjustment is very close and enables the detector tube to be regulated to maximum sensitivity with a minimum of tube noise. If the filament or plate voltage is too high, the signal will be accompanied by a loud objectionable hiss. If the filament or plate voltage is too low, the sensitivity will rapidly drop off. If the filament current is extremely low, this may cause a howl in the audio amplifier.

When two or more radio frequency amplifiers are fed from the same plate battery the resistance of the battery acts as a coupling medium, this coupling between the amplifier stages tending to cause regeneration and oscillations. This means that the amplifier will oscillate long before the maximum possible amplification is obtained. This can be counteracted to some extent by the use of choke coils and by-pass condensers. Such choke coils are only useful over certain wavelength ranges. By using separate plate batteries for each stage and shielding the batteries of one stage from the batteries of the following stages, this plate coupling is eliminated. This system together with the other details of design raise the radio frequency amplification from eight per stage in an ordinary receiver to a figure of 16 per stage. Considering that there are four radio frequency stages, the total amplification gain is from 4096 to 65,536. In actual operation it means that this new efficient radio frequency amplifier will enable the detector to respond to a signal over 100 times weaker than an ordinary four stage radio frequency amplifier will respond. It is well to remember that the fact that each radio frequency stage is shielded means nothing, but the fact that each stage is completely shielded without any detrimental absorption or loss is the difference between an ordinary receiver and the Silver Ghost.

Some multiple condenser receiver designs now on the market have elaborate radio frequency transformer shielding and no condenser shielding. As the condenser stators are connected directly to the grids of the radio frequency amplifiers, it is very important that these stators be properly shielded from each other and from other parts of the circuit.

With reference to the Plate batteries used in the radio frequency amplifiers, two 45-volt batteries are used in each of the first four units and a 22½-volt battery in the Detector Unit. Usually 67½ volts is sufficient for the first four r. f. stages. This amount can be increased or reduced as desired accordingly to the amplification required.

LONG WAVE RECEPTION, 5,000 TO 25,000 METERS (Experimental)

For the reception of these wavelengths iron core transformers (untuned) such as the RCA 1716 can be inserted in the 2nd, 3rd, 4th and Detector units. The antenna unit has to be fitted with a suitable in-

ductance such as a honeycomb coil, this coil tuned by the antenna or first r. f. stage condenser. At these wavelengths the variable condenser will only provide a wavelength ratio of 2 to 1, that is 5,000 to 10,000 meter, 8,000 to 16,000 meters, etc., and more than one honeycomb coil is required. The transformers and honeycomb coils are preferably mounted on bases, so that they are readily interchangeable with the tuned radio frequency transformers.

The radio frequency transformers, being iron core, do not require a tuning condenser and these transformers should be connected to the base so that the stator of the variable condenser is not connected, the transformer only being connected to Grid and Filament and Plate and B plus. On these high wavelengths most of the signals are continuous wave transmitters which require a second source of oscillations to provide an audible signal. A General Radio Type 384 Radio Frequency Oscillator would be suitable for this purpose, as well as providing a source of external oscillations for obtaining continuous wave reception over the short wave lengths down to 35 meters.

SHORT WAVE RECEPTION, 10 TO 200 METERS

(Experimental)

For short wave reception of wavelengths of 10 to 200 meters the experimenter can add a frequency changer and use the Silver Ghost as an intermediate amplifier. The BB Transformers placed in the Silver Ghost set at 3,000 meters make a very satisfactory intermediate amplifier. The Detector and Oscillator of the Frequency Changer are coupled to the 2nd R. F. unit using the Plate Coil of that unit as the coupling coil from the Frequency Changer to the Silver Ghost Intermediate Amplifier. The antenna tuning inductance and oscillator coupler of the Frequency Changer must be suitable for the wavelength to be received. If this is a range of 10 meters to 200 meters a series of antenna inductances and oscillator couplers would have to be supplied on interchangeable bases. A suitable circuit for this experiment is shown in the diagram marked "PALMER LONG WAVE AMPLIFIER." The coupler OC would be omitted, the Plate of tube V would connect to left hand post P on the 2nd Silver Ghost unit and the wire running to the 90-volt B plus post would go to the 90-volt B plus post on the 2nd R. F. unit. In this case the radio frequency transformer in the 2nd R. F. unit would be the input coupler to the intermediate amplifier. In this diagram the oscillator condenser is .0005 mf. and the antenna condenser .00045 mf., these values would be high for tuning such short wavelengths. It would be more desirable to have each of these variable condensers of .00025 mf. maximum capacity.

When experimenting with this type of reception it is not necessary to disturb the regular Silver Ghost set-up if desired. Instead of cutting into the 2nd R. F. unit as just described, the Frequency Changer can be coupled to the antenna coil of the 1st R. F. unit. This is accomplished by connecting a small honeycomb coil of 200 turns to the Frequency Changer in place of the primary of the transformer OC, this coil would be connected at points P and B plus by two flexible leads and the coil inserted inside of the Antenna Inductance (BB) in the 1st R. F. Unit. The distance between this coil and the Antenna Inductance will govern the selectivity of the entire arrangement. As the distance is increased, the selectivity increases and the signal strength decreases.

It should be pointed out that there is not any advantage in using the above Frequency Changer for wavelengths above 200 meters. Above the wavelength range of 200 meters the radio frequency amplifier in the Silver Ghost has repeatedly given results far superior to any Super-Heterodyne system tested in comparison.

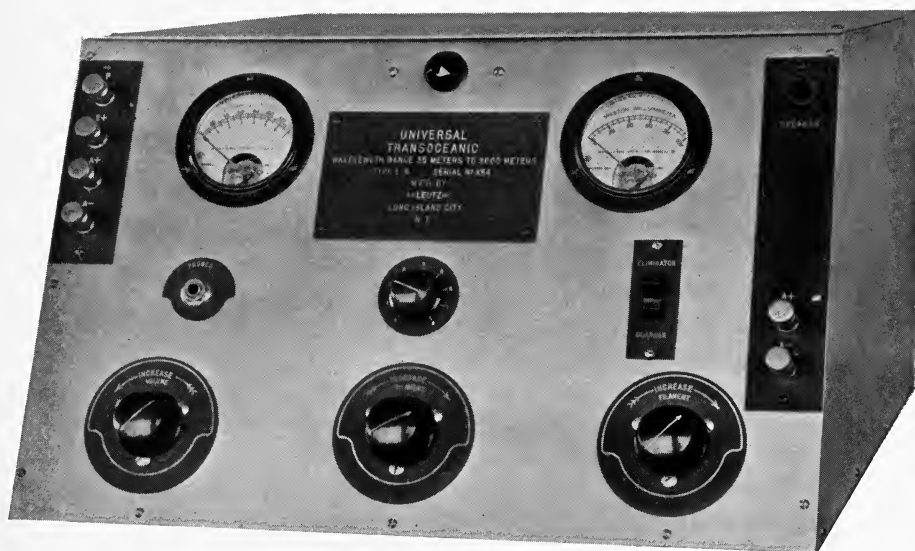

Frontview—Four Stage Audio Unit Silver Ghost.

Fig. 135

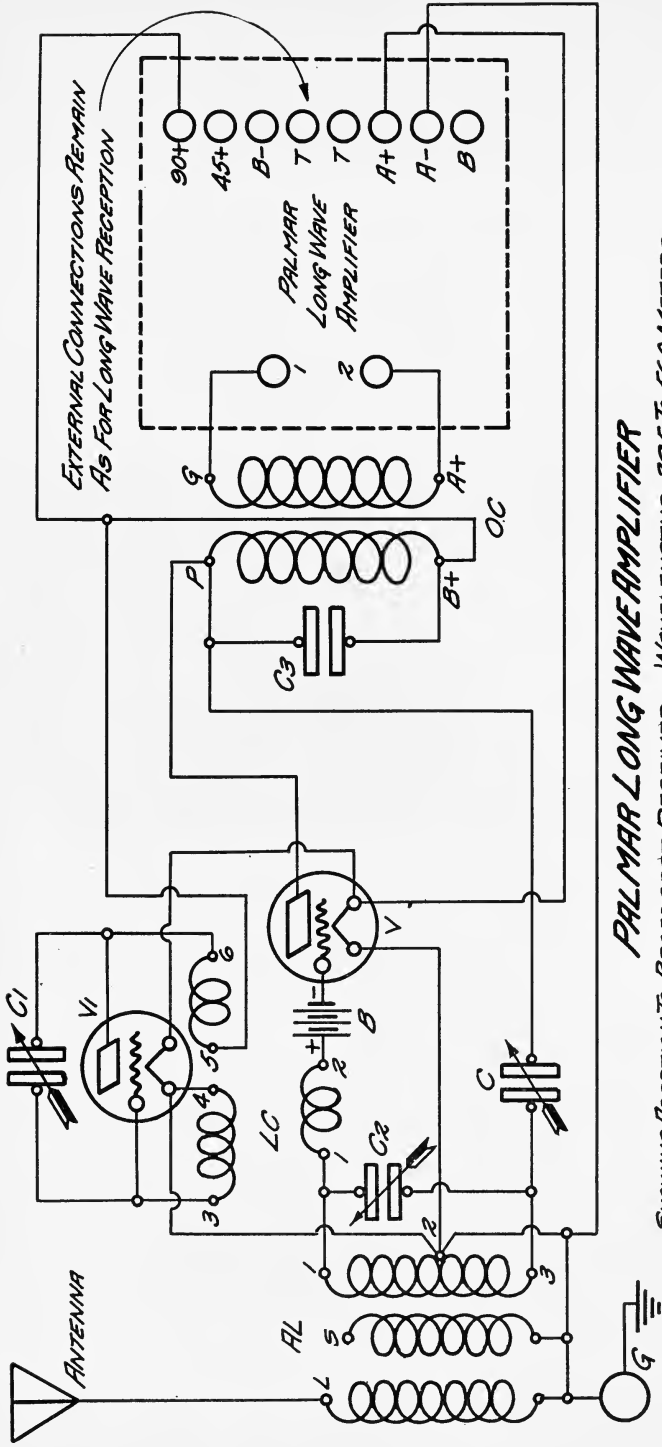

EXTERNAL CONNECTIONS REMAIN AS FOR LONG WAVE RECEPTION

PALMAR LONG WAVE AMPLIFIER

- SHOWING ADAPTION TO BROADCAST RECEIVER — WAVELENGTHS 225 TO 560 METERS
- AL = TYPE C7 ANTENNA INDUCTANCE
- OC = TYPE C7 OUTPUT COUPLER
- C1 = 000.5 MF. G.R. CONDENSER 247
- C2 = 000.25 MF. G.R. CONDENSER 247
- C3 = 01 MF. TYPE 640 DUBILIER COND.
- V1 = RADIO TRON AND SOCKET
- V2 = BIAS OF APPROX. 9 VOLTS - NEG.
- V3 = TYPE C7 COUPLER

Fig. 136

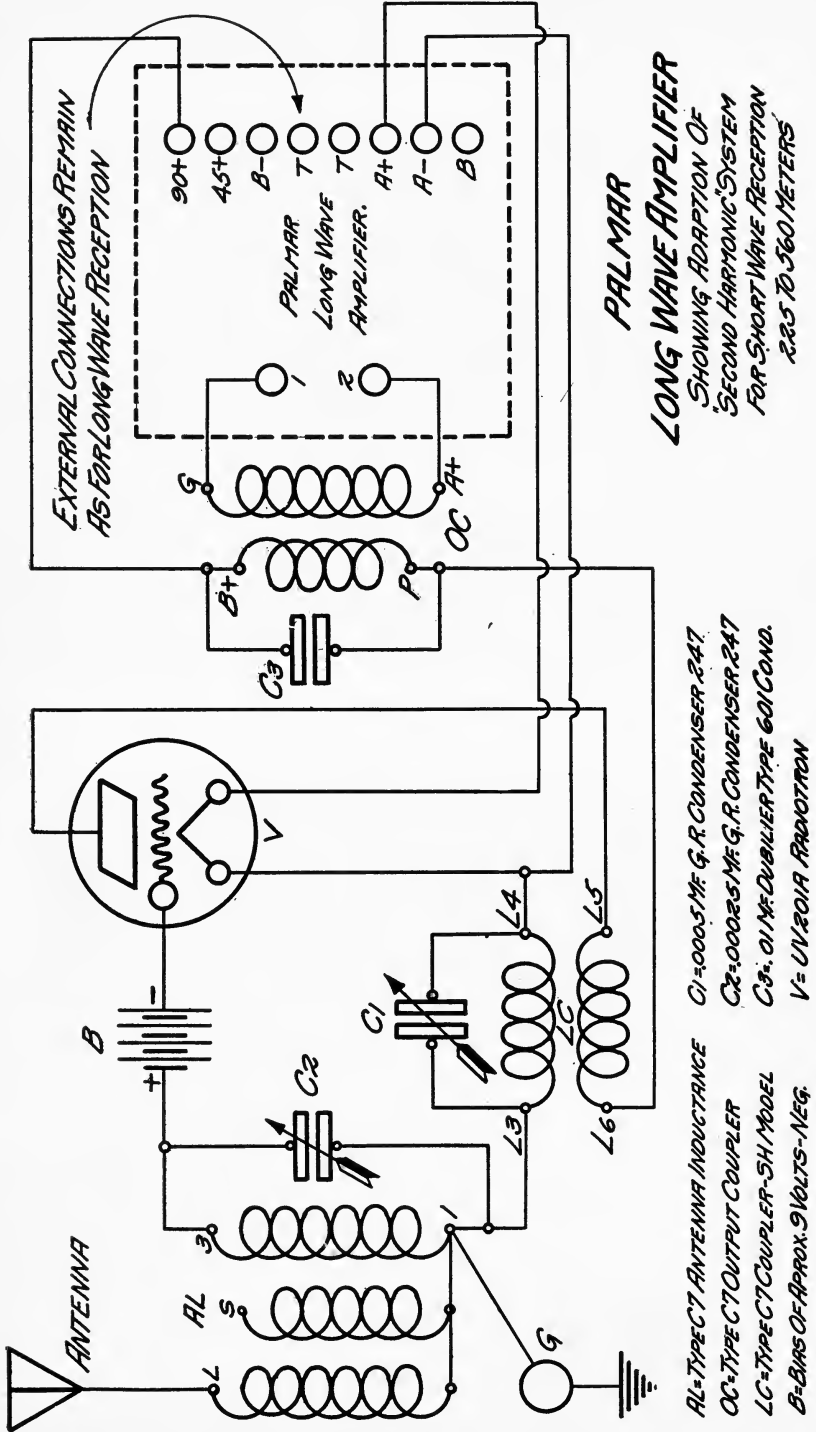

Fig. 137

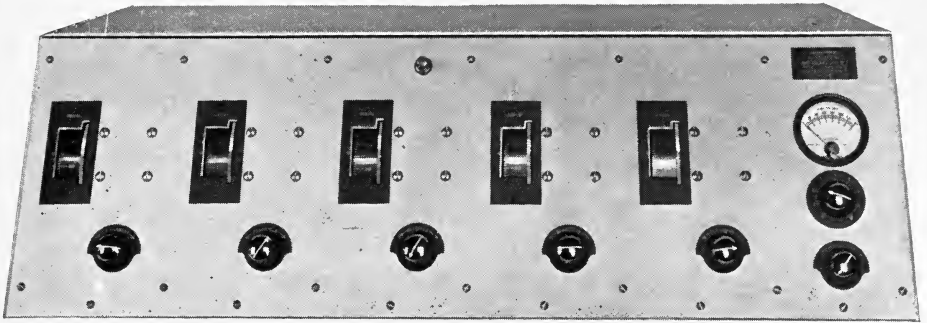

Fig. 138

Front View Universal Transoceanic, showing the panel arrangement. When the five tuning controls are connected together, single dial tuning is possible by moving any one of the five controls. Using single dial control, the small vernier "Resonators" are used for fine adjustments in tuning.

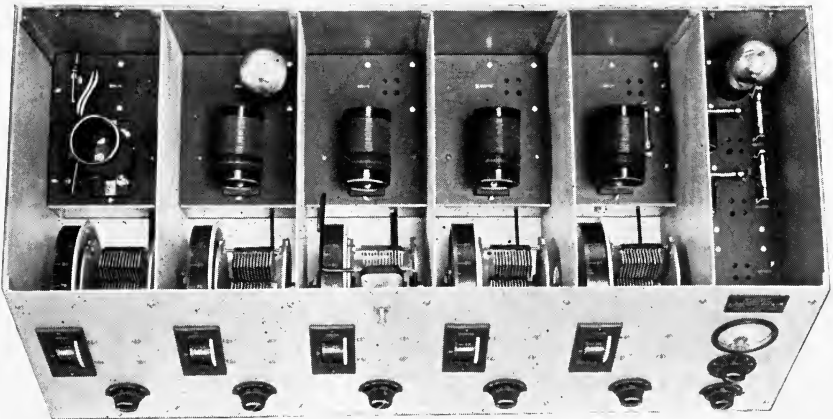

Fig. 139

Plan view of the Universal Transoceanic. Only two of the nine tubes are shown in place. Note the shielding barriers between each radio stage and the one shielded compartment for the four audio stages. The loop adapter and antenna series condensers switch are shown in the first compartment at the left.

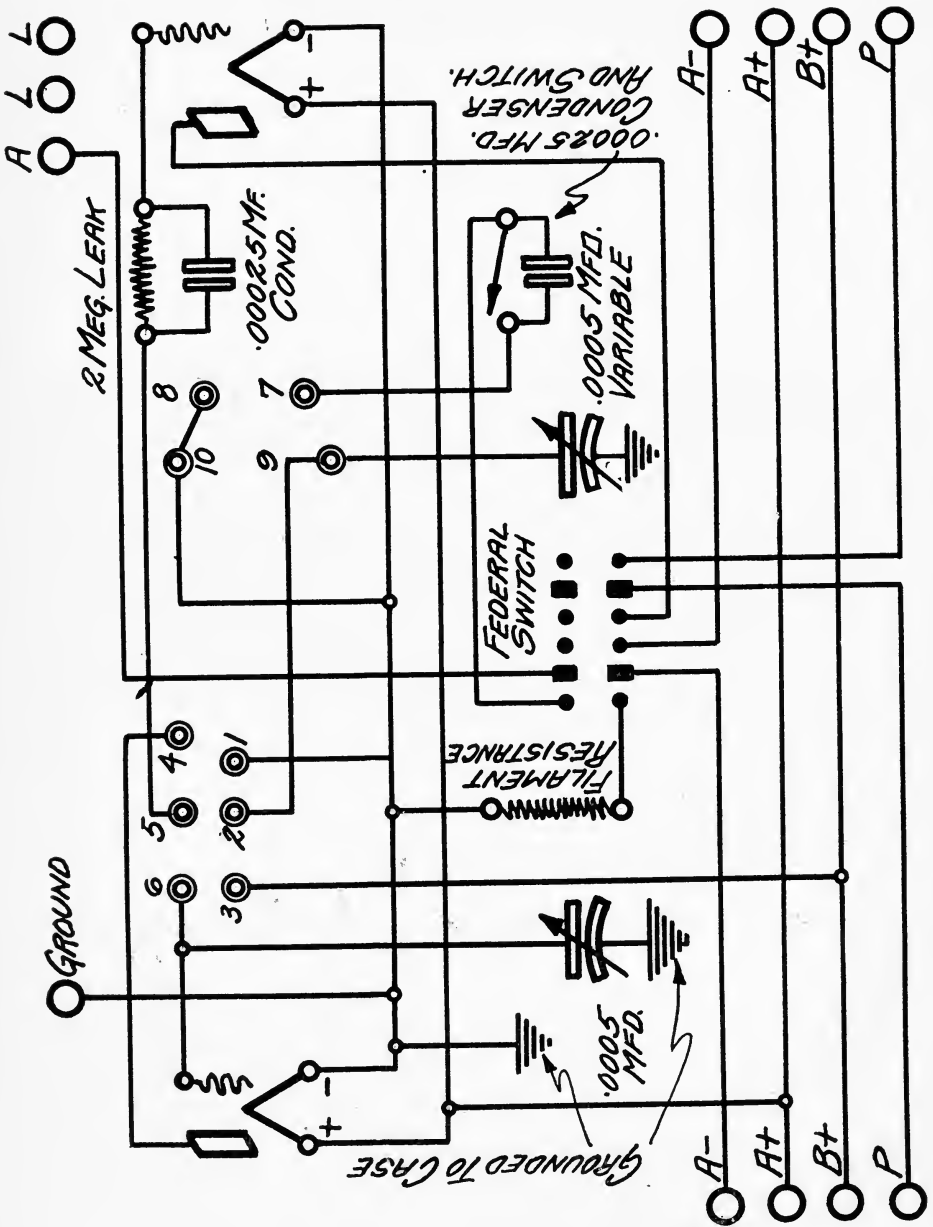

Fig. 140
Frequency Changer Schematic Wiring Diagram

UNIVERSAL TRANSOCEANIC "PHANTOM"

The radio public has become so accustomed to have its receivers inclosed in a mahogany or walnut cabinet that a receiver not thus housed comes as a shock to many. The Universal Transoceanic strikes a new note in external design, in that it is housed in a dull-finished, natural color aluminum case with all the tuning and other controls set in contrasting black.

To many radio enthusiasts this arrangement is attractive. However, to those who prefer the more usual form of housing for the receiver, special cabinets of wood are available. On the other hand, the cabinet instead of being finished in natural dull aluminum, can also be supplied with a Dull Black Finish, Imitation Mahogany Grain (similar to metal furniture) or enameled in practically any color desired to match the surroundings of a certain color scheme.

It has been the manufacturers intention to provide in this receiver extremely high efficiency, and to include nothing that does not make toward this end.

The greatest possible leeway has been provided to permit the owner to adapt this set to his needs. Any type of power tube may be used in the last audio stage. Any sort of "B" power may be used, dry "B" batteries, storage "B" batteries or a "B" power pack. The tuning may be limited to as many as five dials or to one dial as will be explained later. Any sort of antenna may be used, indoor, outdoor or loop. The receiver is equipped with plug-in radio frequency transformers that cover the broadcast wavelength band of 200 to 560 meters and others may be obtained to extend the range down to 35 meters and up to 3600 meters. Transformers for even higher wavelengths than this are made up to special order.

The receiver consists of four stages of tuned radio frequency amplification a detector and four stages of audio frequency amplification, requiring nine tubes in all. Each of the radio frequency stages is shielded separately and the complete audio frequency amplifier is totally shielded from the rest of the receiver. The aluminum case serves as part of this extensive shielding system and also provides practically total shielding for the receiver from external influences.

Each radio frequency stage is provided with a variable tuning condenser, as is the detector circuit. Thus there are five tuning condensers in all, and each is adjustable by a control drum projecting through the front panel. A novel feature of this arrangement however, lies in the fact that the rotors of these five condensers are provided with connecting universal joints and clutches, all assembled in a straight



Fig. 141

Front View Frequency Changer for Silver Ghost. This unit is connected between the first and second units of the Silver Ghost. The unit pictured was built for experimental purposes only. This instrument is not available for sale due to certain patents.

line. By tightening a screw in the clutches, the five condensers can be instantly connected together and all five controls operated simultaneously from a single control. The receiver can then be operated as a single control receiver.

Due to the fact that the antenna tuning control usually has a varying setting due to the influence of the antenna capacity, it is best practice to leave the first or antenna control separate and connect the remaining four controls together. This gives a simple two dial system which is very efficient. In the event the four controls are not accurately set or if there are any capacity differences due to tube changes, these small variations in resonance can be corrected with the vernier adjustments provided. These adjustments are marked "Resonators."

It is not essential, however, that the controls be coupled together, best distance records have been reported with the dials individually operated. Tuning with five controls is not nearly so much of a problem as it would appear at first glance. When a given station is tuned in it will be found that all but the first dial show almost exactly the same setting when using the regular "A" size coils for 200 to 560 meters. That is, if a certain station is tuned in at a given setting on the second control, the third, fourth, and fifth dials will all show within one or two degrees of the same reading.

The tuning dials are calibrated in 100 divisions and not on meters. This is necessary as the dials must do for five different sets of radio frequency transformers. The extra radio frequency transformers cover the following wavelengths, "C" 35 to 90 meters; "B" 80 to 210 meters; "AA" 500 to 1500 meters and "BB" 1200 to 3600 meters.

Due to the unusual strength of received short wave signals it is unnecessary to use four stages of tuned radio frequency amplification for the "B" and "C" transformers. Two stages of tuned radio frequency are necessary for these wavelengths (three tuning transformers and controls) and the extra two stages not required can be instantly cut out of circuit through the use of a "Stage Adapter." This adapter is not supplied with the receiver as regular equipment but as an extra.

A voltmeter and switch is provided at the right hand end of the receiver. This voltmeter is one of the many attractive features of this receiver as it will measure every voltage used in the receiver, A, B, or C. For instance if the switch is set to point one it will read the "A" battery or "A" supply voltage under load. Point two gives the voltage at the Detector tube filament and Point 3 the filament voltage as supplied to the four radio frequency amplifier tubes. Point 4 gives the bias voltage applied to the first three audio stages. All these four readings are taken on the lower scale of the voltmeter which may be 0 to $7\frac{1}{2}$ or 0 to 8 volts

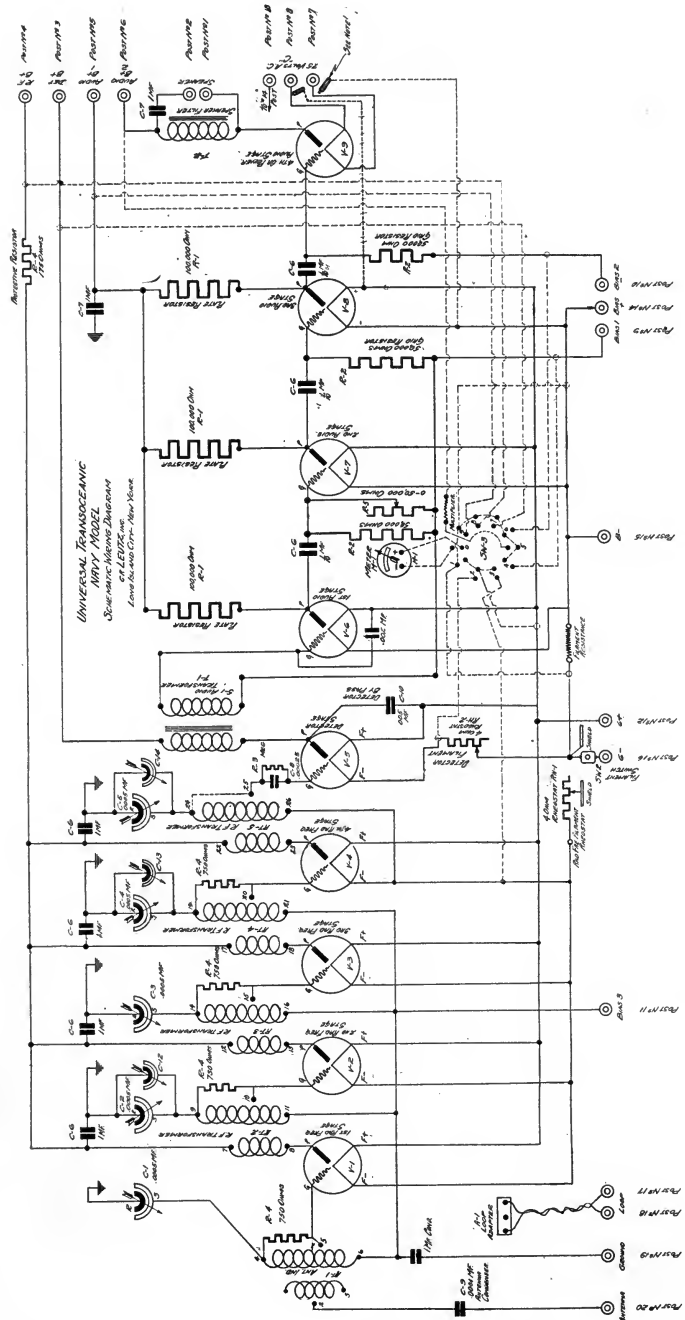

Fig. 142
Schematic Wiring Diagram Universal Transoceanic.

full scale. Point 5 reads the power audio amplifier voltage, this is usually obtained by multiplying the upper scale of the voltmeter as indicated by 5. For example if the reading was 100, the total voltage would be 500 for the power amplifier tube plate. If the multiplication factor is different than 5 it is so stated in the instruction book. This factor varies on account of the voltmeter series resistor or multiplier used. Point 6 measures the negative bias applied to the power amplifier grid. Point 7 reads the Detector plate voltage, 8 the Radio Frequency Amplifier Plate voltage and 9 the audio frequency tubes plate voltage (first three stages only).

The voltmeter therefore not only permits the proper filament voltages to be maintained (by means of the two rheostat controls on the receiver front), but also provides an easy check on the other voltages used. This simplifies the proper voltage adjustments where a power-pack with variable outputs is used to supply the high voltages.

It should be stated here that no fixed set of meter readings will do for all receivers, the proper voltage adjustments are those that provide best results rather than setting for any fixed values. The meter also serves as a quick check on the voltage of the batteries, if batteries are used for operating the receiver. During the testing of these receivers, the voltmeter readings are very useful in locating any troubles which exist during the preliminary tests.

The receiver will provide best all-around results, of course, when an outdoor antenna is used. In congested areas the length of an antenna should be 150 feet. As the receiver is very selective a longer antenna than this can be used if the operator is skillful in operation.

No skill is necessary in order to separate all local stations, but to secure 10 to 15 degree selectivity requires a fair amount of practice. Out in the country a longer antenna can be used and a series condenser is provided with a switch for either connecting it in or out of the circuit. Using a long antenna which is especially efficient for the longer wavelengths this same antenna can be equally efficient for the shorter wavelengths by throwing the antenna series condenser in circuit. This condenser is in the circuit when the shorting switch is open. This switch is located in the first left hand compartment.

For those that prefer a loop it may be readily used. The first radio frequency transformer is removed from its socket and the Loop Adapter (a small base with three plug contacts) is inserted in its place. Two binding posts are provided in the rear of the receiver to connect the loop leads.

The maximum selectivity of this receiver was demonstrated to Mr.

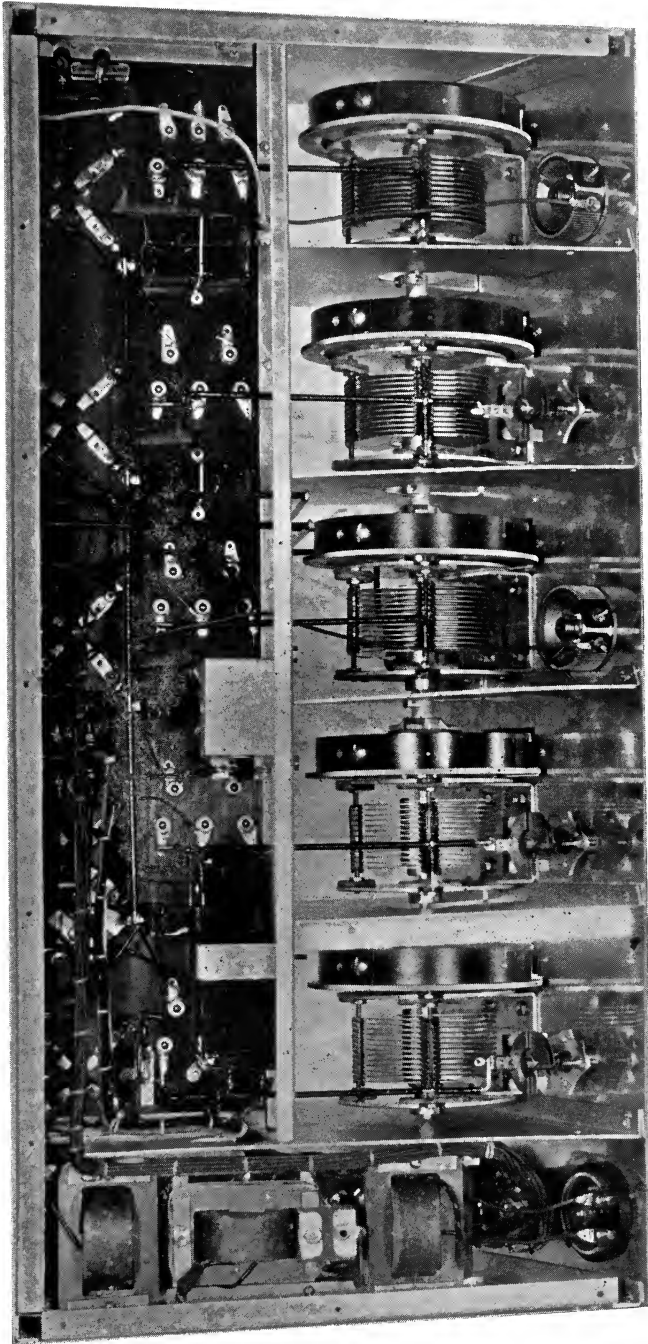

Fig. 143
Inside Bottom View Universal Transoceanic.

Taylor one of the Engineers of "Radio Broadcast" at Long Island City by the manufacturers of this receiver.

Using a 150 foot antenna it was found possible to separate WPG Atlantic City, from WMSG, a New York City station, while operating the receiver approximately three miles from the latter. The wavelength difference between these two stations was only three meters. If the two stations were any closer together they would heterodyne with each other. This is the maximum selectivity permissible in a radio receiver for telephone work as any additional selectivity would detract from the quality of the musical reproduction.

The recommended tube arrangement is as follows: 201A's for the first four tuned radio frequency stages, and for the first audio stage. UX200 or CX300 for the detector (not 200A). Hi-Mu for the second and third audio stages and a power for the last audio stage. The three distinct types of tubes for the audio stages is made necessary for the combined transformer and resistance coupled audio amplifier. The power tube selected for the last audio stage is determined by the voltage available, 201a being used for up to 100 volts, 112 for up to 135 volts, 171 for 180 volts and the 210 for 550 volts.

The plate current for the proper audio tube is filtered from the loud speaker by a special output choke and condenser. This choke is undoubtedly the largest and most substantial output choke used in any broadcast receiver. It weighs about five pounds and wound with heavy wire and well insulated it enables using 550 volts on the power audio tube with complete safety and at the same time provides maximum undistorted power output from the power tube to the loud speaker. The first audio transformer is of similar construction, also weighing about five pounds and wound with heavy wire. The amplification curve over the musical scale is ideal and the mechanical construction so substantial that it is suitable for practically a perpetual life under any climatical conditions.

Using resistance coupling in three of the audio stages it is possible to secure both distortionless amplification with great stability of operation, and fine musical reproductions. The resistance units are made of special material which is practically indestructable and free from any climatic influences. There is a further advantage in that the resistances can be selected for the proper values to agree with the tubes and voltages for the audio amplification.

In the accompanying photographs and drawings the stopping condensers between the audio frequency tubes are shown as large condensers on top of the sub-panel. This has since been changed to small

stopping condensers which are connected and mounted directly underneath the sub-panel. These condensers have a capacity of .01 MF.

The regular range radio frequency transformers are wound on forms $1\frac{1}{2} \times 1\frac{3}{4}$ inches in diameter and $2\frac{5}{8}$ inches long and the turns are equally spaced over the winding distance, that is each turn is separated from the next turn of wire by an air space. This system of winding reduces the distributed capacity of the transformer secondary inductance winding. As the coils are machine wound all the transformer secondaries have practically the same identical inductance. Even if there is a slight variation in the factory run, the coils can be matched up and separated in groups of five which provides a set of transformers of exactly the same tuning range and easily adapted to simultaneous tuning with the tuning controls coupled together.

Each radio frequency amplifier tube and transformer is provided with a 1 MF by-pass condenser which prevents parasitic coupling back through the battery or other leads. This is a total of 4 MF by-pass compared with about $\frac{1}{2}$ MF in ordinary receivers.

The variable condensers in the radio frequency circuits are of low loss construction. In order to prevent any variations in capacity due to mechanical mis-alignment, the five condensers are mounted on a reinforcing sub-channel along the front panel. The mechanical adjustments then remain perfect during shipment. It should be pointed out however that it is not advisable to ship the receiver with the condensers coupled together.

The receiver is supplied to the owner with a calibration sheet showing the exact dial settings for several of the stations tuned in. This includes at least one station 2000 miles distant from the point of testing which is usually Long Island City. In connecting the condensers together for single or double dial control it is not advisable to go by the calibrations. This is due to the fact that the calibrations differ slightly with the tubes used for the radio frequency stages.

To secure best results with single dial control the receiver should first be used with individual control and ten or fifteen stations tuned in carefully and the calibrations taken. These calibrations are later used as a check when using single control. After securing these calibrations a weak station is carefully tuned in around 50 on the dial. The "Resonators" should be set at the vertical or "neutral" position. With the station turned on for maximum response the 4th and 5th dials should be connected together first. Then retune to see that the other dials have not moved and connect the 3rd and 4th dials together. Following the same system and connect the 2nd and 3rd dials as one. Then by moving any one of the last four dials these four dials will move as one. By

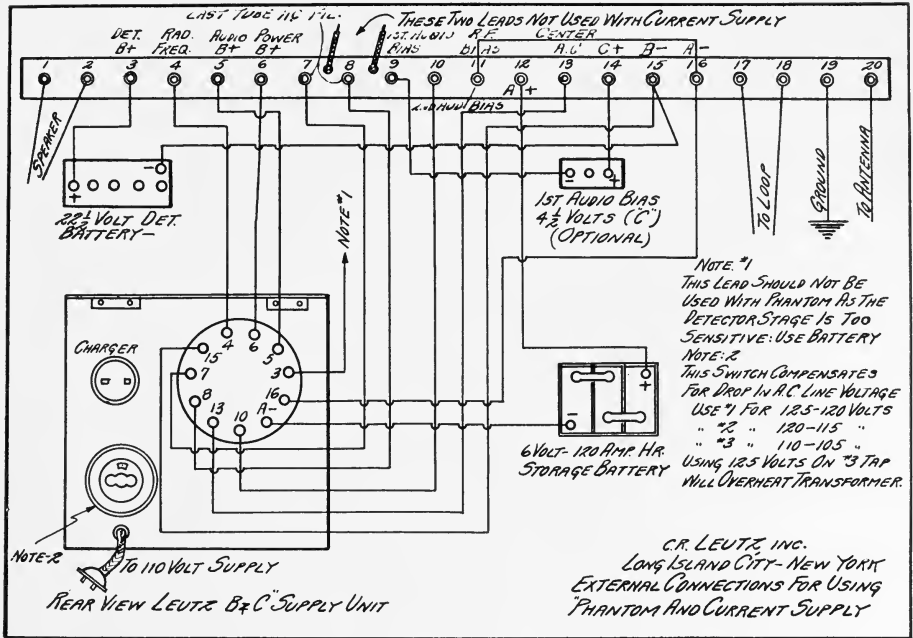

Fig. 144

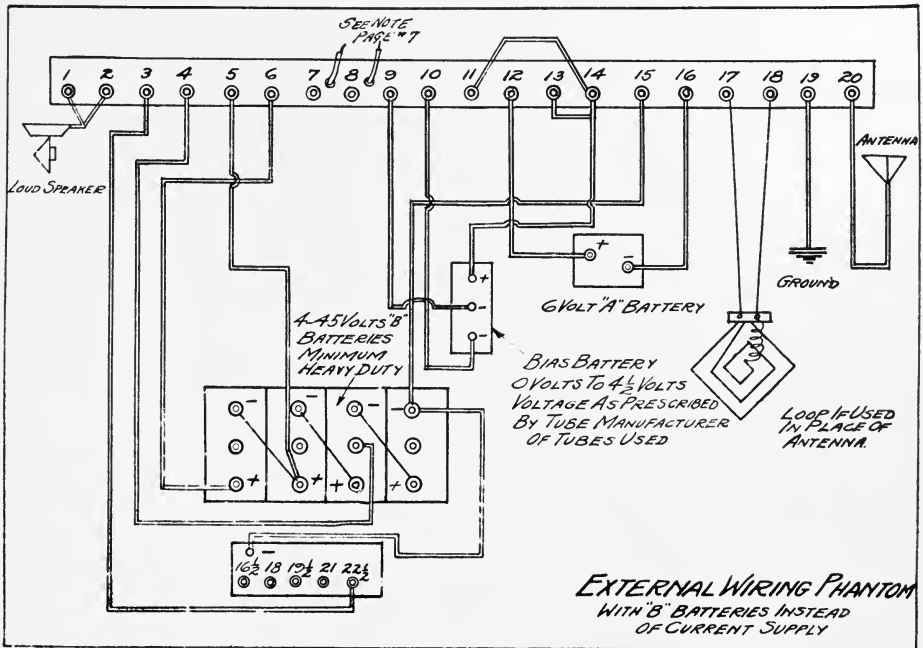

Fig. 146

trying the "Resonators" it will be a check to see if the connections are properly made. If any of the "resonators" have to be moved for the same station it is proof that the dials are not accurately set and a re-adjustment should be made. However with the dials all set perfectly at 50 on the scale, it may be necessary to adjust the "resonators" for weak stations toward the upper or lower ends of the condenser tuning scales, which is to be expected. If the operator has any great difficulty in tuning five dials at first, the Stage Adapter can be used to cut out one or two stages (using 3 or 4 dials) until accustomed to the multiple tuning.

The battery and other connections are made at the rear of the receiver through 20 binding posts provided on a terminal strip. These posts are unnumbered 1 to 20 and have the following purposes:

- 1 and 2—Loud Speaker.
- 3—Detector B Plus— $16\frac{1}{2}$ to $22\frac{1}{2}$ volts for UX200.
- 4—Radio Frequency Plate B Plus $67\frac{1}{2}$ to 90 volts.
- 5—First three audio Plate B Plus 90 to 200 volts.
- 6—Power Audio Bias Negative.
- 7 and 8 Power Audio Filament Terminals.
- 9—First Audio Bias Negative.
- 10—Power Audio Bias Negative.
- 11—Radio Frequency Amplifier Grid Bias Negative.
- 12—A Supply Positive.
- 13—Center return for power tube (negative A)
- 14—Bias Plus return (negative A)
- 15—Common B minus (negative A)
- 16—A supply negative.
- 17 and 18 Loop if used.
- 19—Ground.
- 20—Antenna.

In the event low first audio B voltages are used it is advisable to omit the first audio negative bias and this is accomplished by connecting post No. 9 directly to post No. 14. If it was desired to check up on the B current consumption of all the tubes in the receiver a milliammeter would be connected in series with the wire running to post No. 15 which is the common B minus terminal. With the present tubes available an additional radio frequency bias is not advisable and accordingly post No. 11 is also connected directly to post No. 14. When the new UX222 tubes are available the post No. 11 can be used to good advantage.

As the receiver is now wired the maximum possible radio frequency bias permissible is automatically provided without batteries. This bias of about 1 volt is obtained through the drop in voltage at the

radio frequency filament rheostat. The grid returns are run to the battery side of the rheostat to the negative potential the grid returns are run to the battery side of the rheostat of the radio frequency filaments. For example if the radio frequency filaments were set at 5 volts there would be one volt bias on each of the radio frequency tube grids. This bias adds to the selectivity of the receiver and is a feature generally overlooked in ordinary receiver designs.

The first three audio tubes do not usually require any external bias. These three tubes have their filament voltage automatically regulated to 5 volts by means of a fixed resistor. By connecting the grid returns of these three tubes to the battery side of the fixed resistor and by means of the grid leaks provided, a satisfactory audio bias value is obtained for these tubes when using any "B" voltage up to 200 on the plates. The power audio tube however may require from 9 to 40 volts bias and this is best supplied from an external battery or from the Power Pack.

This receiver has been specially designed for the UX200 or CX300 detector tube. In an ordinary receiver this detector tube will not give any better results than a 201A detector. However if the designer understands the superiority of the UX200 detector the receiver can be so designed that its operation with this detector tube will be infinitely superior to any other detector tube.

One of the requirements is a powerful audio amplifier, not less than three stages and still better four stages. The first audio transformer must have special characteristics. An ordinarily 201A tube used as a detector with a four stage audio amplifier is so microphonic that stable operation is almost impossible. The UX200 has a heavy Tungsten filament, very rigid even when white hot and is practically free from the effect of mechanical vibrations. Another requirement is that provisions must be made for an absolutely constant plate voltage. The exact value is usually between 18 and 22½ volts.

Detector batteries were formerly with taps every 1½ volts from 18 to 22½ but are now only supplied with two taps, one at 18 and one at 22½. Values in between can be obtained by adding or subtracting voltage by using a small 4½ volt C battery which has taps for 1½, 3 or 4½ volts. Another method of accurately adjusting the plate voltage is through the use of a potentiometer. The potentiometer is connected directly across the 6 volt A battery terminals. The Negative terminal of the 22½ volt battery instead of running direct to negative A is connected to the center post of the potentiometer. By regulating the potentiometer, the storage battery potential or voltage may be subtracted from the B battery potential to give a very fine adjustment of the actual B battery potential between the Detector Plate and Detector Negative Filament terminal.

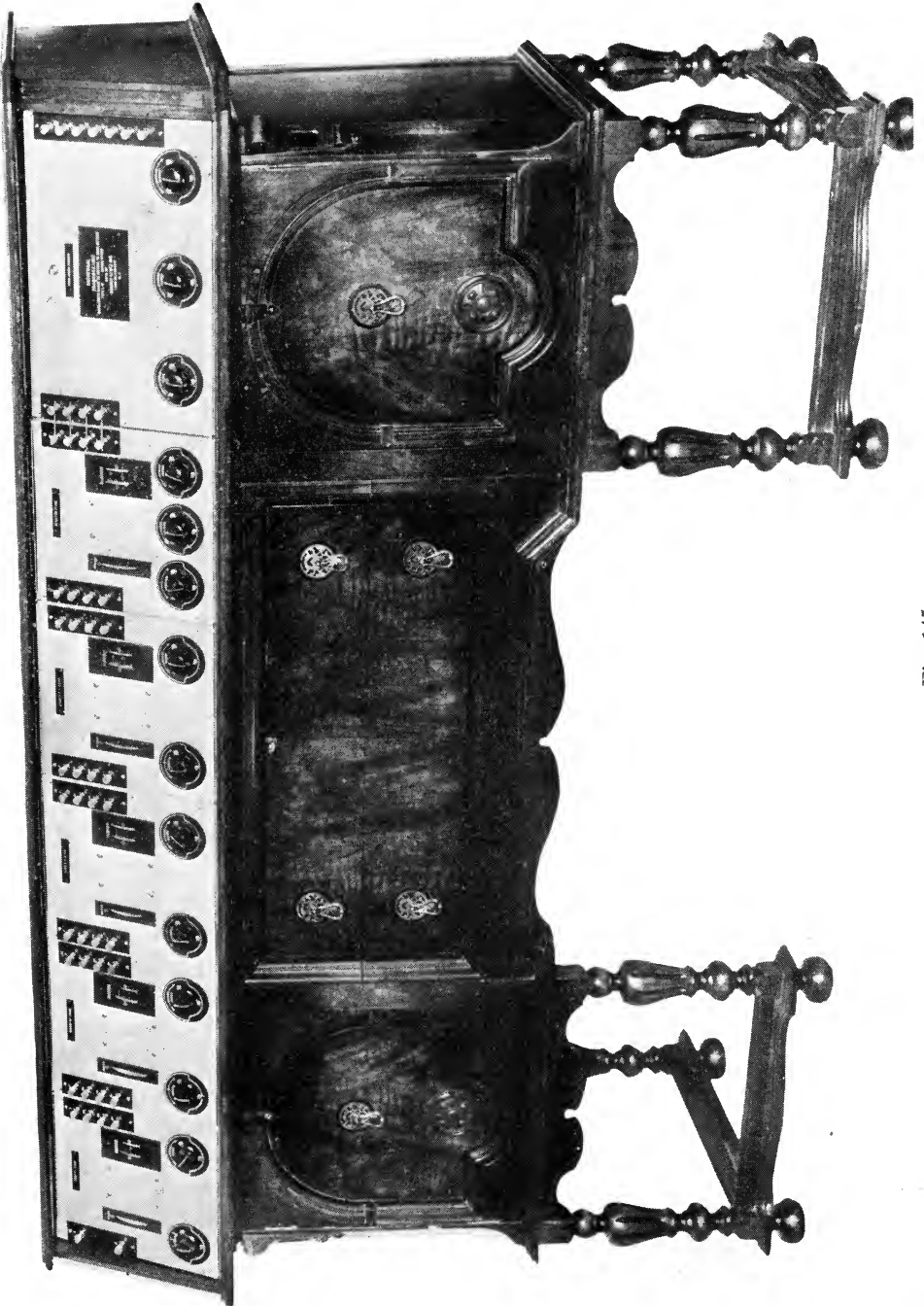

Fig. 145
Transoceanic Silver Ghost Console.

POWER AMPLIFICATION AND THE SPECIAL "B-C" CURRENT SUPPLY

The Type L Special B-C Current Supply is designed to operate continuously without overload when feeding four radio frequency amplifier tubes at a maximum of 100 volts, one detector tube at $67\frac{1}{2}$ volts, three audio frequency amplifier tubes at a maximum of 200 volts and one power amplifier tube at a maximum of 450 volts. In addition supplying the above B voltages, the supply also gives a bias of 30/40 for the power amplifier tube grid, a filament of $7\frac{1}{2}$ volts for the rectifier tube and a filament supply of $7\frac{1}{2}$ volts for the power amplifier tube. The two $7\frac{1}{2}$ volts supplies are raw alternating current leads with accurate center taps on the windings. The total milliamperes supply may be as high as 65 at 400 volts with safety.

The idea in building such an elaborate and substantial B and C battery eliminator was to have an instrument perfectly capable of operating the Universal Transoceanic to its maximum output and efficiency.

For Universal Transoceanics built with two UX210 Power Audio Tubes in a push pull system, the Special Current Supply is available with two Rectifier Sockets for full wave rectification and the output is then doubled, 130 milliamperes at 400 volts. Ordinarily the Current Supply is furnished for Half Wave rectification using one rectifier tube to feed a Universal Transoceanic having only one UX210 Power Audio Tube.

This Current Supply is also suitable to operate any type of receiver having six to 10 tubes, but the receiver unless strictly modern in design would have to have a few alterations to use such high voltages to full advantage and with safety.

As different types of tubes work most efficiently with different plate voltage values, the supply voltages have been provided with regulators. There are three variable supplies, No. 1, for the Detector giving 0 to $67\frac{1}{2}$ volts; No. 2 for the radio frequency amplifiers giving 0 to 100 volts and No. 3 for the first audio stages giving 0 to 200 volts. The power audio voltage is fixed usually at 400 volts. The grid bias voltage of the power audio tube is also fixed at the proper amount in proportion to the power audio plate voltage. The power audio plate voltage and power audio grid bias voltage are so arranged that any change in the plate voltage gives a proportion change in the bias voltage to the correct amount automatically. In some models a power switch is provided on the rear of the cabinet giving three different power taps, low, medium and high. Where a supply current of 125 volts was available the low tap would be sufficient and where a

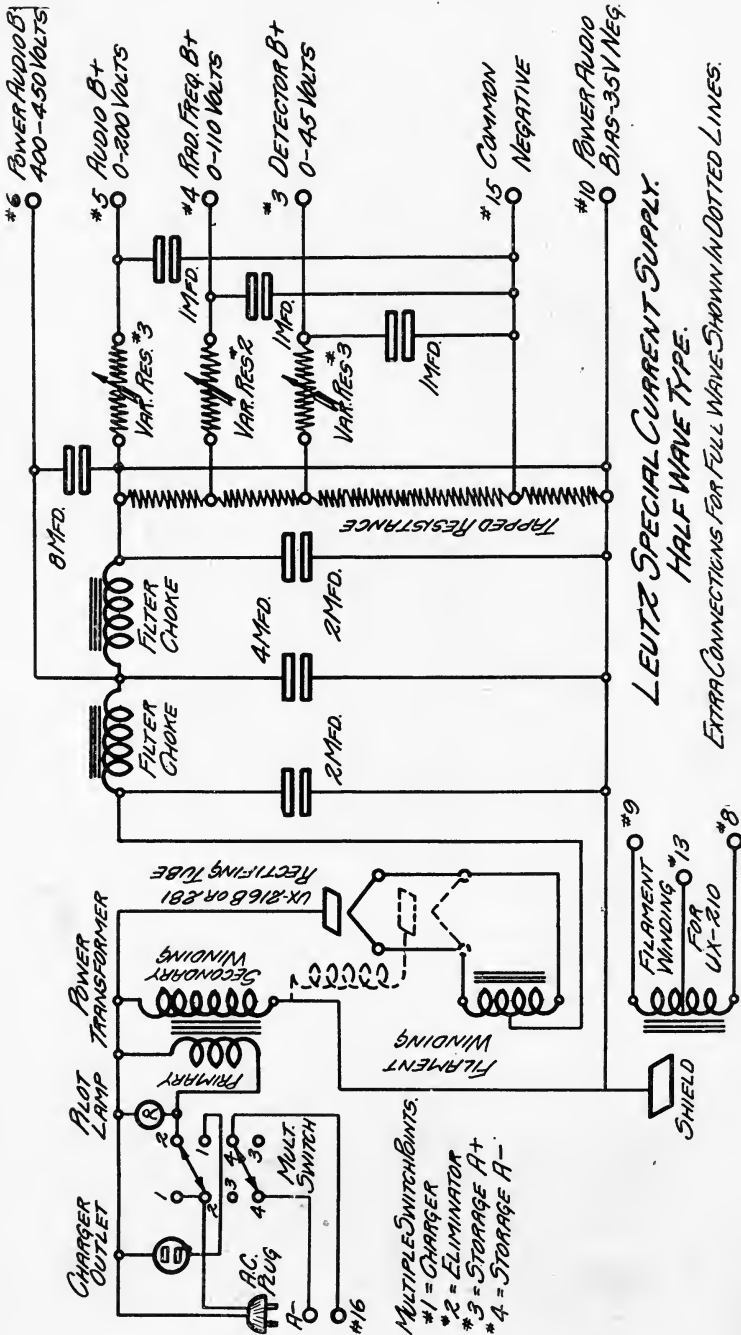

Fig. 147

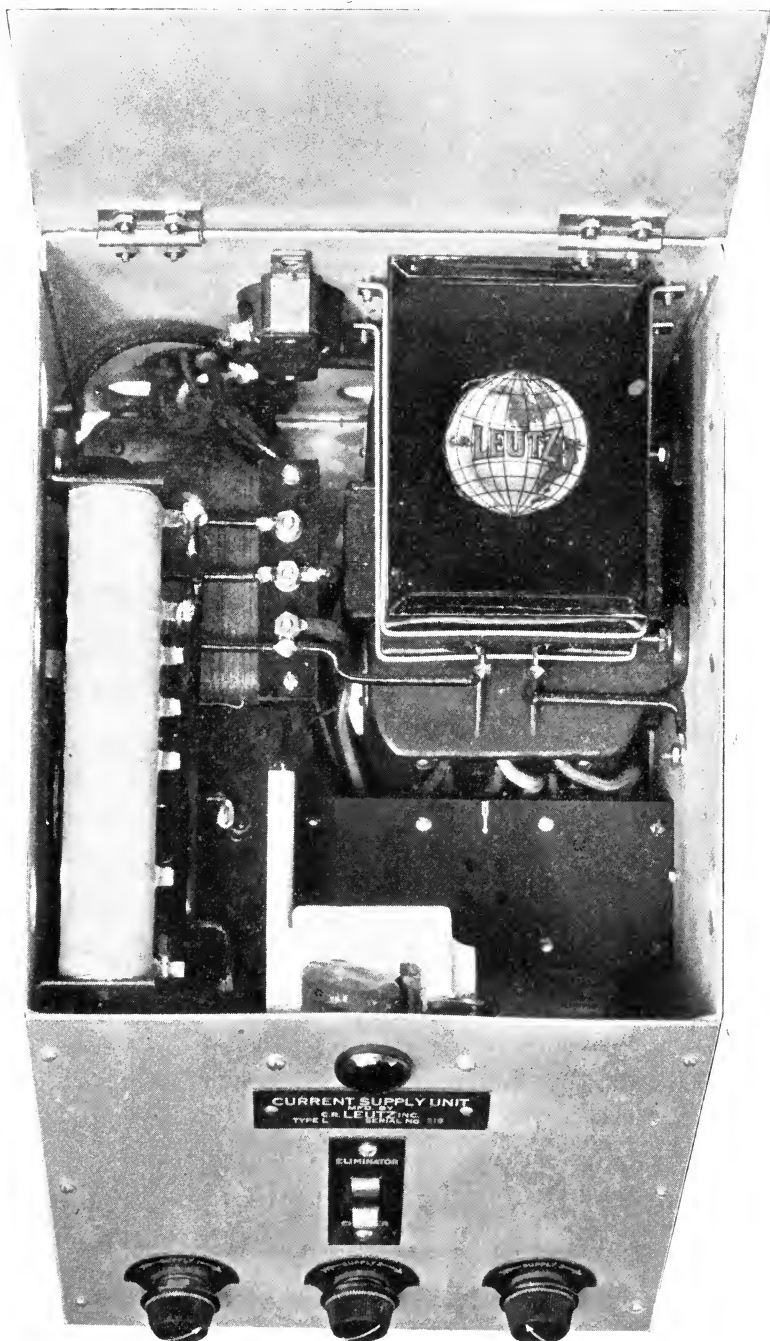

Fig. 148
Internal View—Leutz Special B-C Current Supply.

supply current of 100 volts only was available the high tap would be used. This switch also has an "OFF" position which not ordinarily used as the control switch is located on the front of the panel.

The control switch on the front panel not only controls the "B-C" supply but also controls the filament circuit of the receiver being used and the charging circuit. In the "ON" position, the switch closes the circuit to the receiver filaments, closes the circuit to the B-C supply and also lights up the Red Bulls Eye indicator showing the circuits are in operation. In the "OFF" position the above circuits are opened and the alternating current fed to an outlet at the rear of the case. If a battery charger is connected to the A battery and the charger plug inserted in this outlet, the charger will operate. From the above it will be seen that the charger is always operating when the receiver is not being used and that the charger is automatically shut off immediately when the receiver is turned to the operating position.

When an "A" Battery Eliminator is used, this rear outlet is wired differently so that the A Battery eliminator is also cut into the circuit simulataneously with the receiver filaments and "B-C" supply.

The need of such high voltages and current is best understood by considering the requirements of power amplification. Unlike the grid circuit of a vacuum tube, a loud speaker consumes a considerable amount of power. The action of the last stage of an audio amplifier is therefore different from that of any preceding stage.

In order to understand clearly the difference in the action of the last amplifier stage, it is necessary to consider load impedance in the several stages and the current delivered to them. When amplification per stage is spoken of, voltage amplification is usually meant. It is customary to speak of the vacuum tube amplifier as a purely voltage device. This is not strictly true in any stage and is far from the truth in the power stage. While the grid of the tube operates on voltage alone, the plate must deliver power. The objection to the specification of voltage amplification alone is evident when an amplifier feeding a load of 100,000 ohms is compared with one feeding a load of 2500 ohms. It is proper to refer to voltage amplification alone only when the load impedances are equal; otherwise the load impedances should be specified or a correction applied. When an output transformer is used, the voltage across the primary of the transformer rather than across the speaker should be considered as the output voltage on considering voltage amplification.

The power consumed in the stages of the amplifier prior to the last is not generally appreciable. While the current delivered by the secondary is negligible, exciting current and transformer losses must be supplied by the plate circuit of the preceding tube.

The power requirements of the speaker, however, are large. Some of the power delivered is lost in the speaker windings, but most of it is transformed into sound waves and radiated. Current is required to actuate the speaker, and modern speakers are of comparatively low impedance devices. This requires an impedance adjusting transformer in the Plate circuit of the last tube, which involves a considerable reduction in voltage. The last stage of the amplifier must be capable of delivering an amount of power to the speaker commensurate with the volume of sound desired without overloading the tube if quality is to be preserved. In order to meet this requirement, a power stage should precede the speaker.

It is perhaps necessary to distinguish between a power amplifier and a powerful amplifier. A power amplifier cannot be applied successfully directly after the detector; one or more stages of voltage amplification must precede it. The greater the power rating of the amplifier, the more the voltage amplification required to precede it, as a general rule.

Receiving set power amplifier tubes range all the way from the -20 type with an undistorted output of about 100 milliwatts to the -10 type with an undistorted output of about 1500 milliwatts. As each of these tubes differs as to input requirements, the choice of the power amplifier will depend on the rest of the amplifier. If sufficient signal voltage is not available to operate the power amplifier satisfactorily, nothing is gained by adding it. It is, therefore, necessary to consider the first part of the amplifier in designing the power stage.

Too great voltage amplification in the audio amplifier should not be attempted, as undue noise and unstable amplifier is likely to result. The audio amplifier should not be depended upon for distant reception; that is the function of the radio frequency amplifier.

For satisfactory amplification the detector output should be one-tenth to five-tenths volts (across the primary of the first coupling unit). Signal strengths of less than the lower value should be increased by radio frequency amplification, those greater than one-half volt should be cut down by a volume control device, or otherwise the detector is overloaded.

Assuming a signal of 0.2 volt, and a voltage amplification of 20 (one stage low ratio transformer and tube) there is available for operating the power stage 4 volts. Assuming a 2 to 1 step-up ratio for the input transformer to the power tube, 8 volts are available at the grid of the power tube. The tube data tables show the output under these conditions with various tubes to be as follows:

Power is in milliwatts in each case. As the plate voltage available is generally limited, the plate voltage required is also given. If lower plate voltage are used the input must be reduced to prevent over-



Fig. 149
Front View B-C Current Supply.

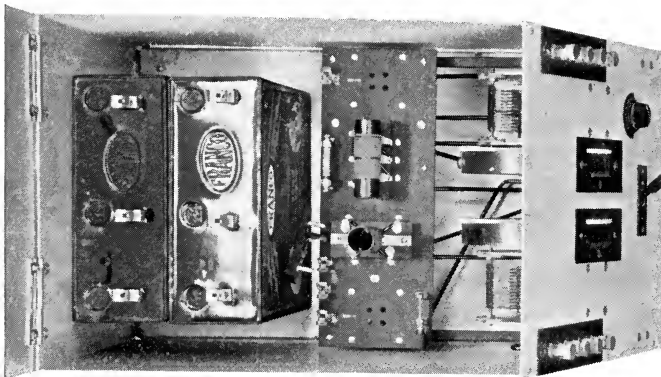

Fig. 150
Internal View
Frequency
Changer

loading, and, as will be observed, this is an important factor in choosing the amplifier tube. This data is calculated from vacuum tube tables and represents average values.

Signal Voltage 8		
Tube	Power Output	Plate Voltage
201A	50	135
120	15	67
112	120	135
171	28	67
210	65	135

Obviously the 112 is the proper tube to use. Suppose, however, the input voltage and amplification ratio had been such as to give 25 volts to the power amplifier tube grid. As neither the 201A nor 112 tube can be used on this voltage the choice reduces to:

Signal Voltage 25		
Tube	Power Output	Plate Voltage
120	110	135
171	350	135
210	950	350

In comparing the 171 and 210 tubes it should be noted that under these conditions the 210 requires a plate voltage of 350 as compared with 135 for the 171 tube. In order to operate with 135 volts on the plate of the 210 tube, the input voltage would have to be cut to 9 volts with the volume control, when the output would become but 65 milliwatts.

Increasing the input still further to 35 volts, only the 171 and 210 tubes may be used, the 171 giving 530 milliwatts output with 170 volts plate, and the 210 giving 1500 milliwatts with 425 volts plate. Again comparing the outputs with equal plate voltages, we find the output of the 210 is only 140 milliwatts at 170 volts plate.

The 171 tube will take a maximum input of 40 volts with 180 volts plate, giving a 700 milliwatt output. So far only single power tubes have been considered. Where considerable power output is required, the push pull connection, using two tubes in a single stage, offers many advantages even where the output desired is no greater than could be obtained with a single tube.

In the push pull stage, two tubes are so connected that their power outputs add. Any type of tube may be used, the choice of the tube depending upon the same consideration outlined as applying to a single tube type. Thus the push-pull connection might be used with the -12 type tubes when the input voltage is too low for operating the 71 type satisfactorily, but when greater power is required than is obtained

with a single -12 type, -71 tubes might be used in order to obtain a greater output than is possible with a single 210 without the high plate voltage need for that type of tube, or 210 tubes might be used where the power output required is several watts.

Fig. 74 shows a typical push-pull circuit for audio amplification. It will be noted that the grid currents flow away from the negative C point and that the plate currents flow toward the B plus point, thus these voltages cancel out and do not appear in the output. This fact is of great importance in the operation of the amplifier as it permits a greatly increased power output. Tube overloading, so long as grid current does not flow, is due to the amplifier working over a curved portion of its characteristic, introducing harmonics of the original frequency. As these harmonics are in phase, they cancel out and do not appear in the output. The working range of a tube is not limited to the straight portion of the characteristic when used in a push-pull amplifier. So greatly is the output increased by this fact, that the maximum undistorted output from the push-pull amplifier is NOT TWICE but IS FIVE TO SEVEN times that of a single tube. This feature is of particular importance when working into the low impedance load presented by most of the modern high quality loud speakers, since the effect of low impedance in the plate circuit is to increase the curvature of the tube characteristic, and lessen its capacity for undistorted power output.

If alternating current supply is used for the filaments of the power tubes a further advantage of the push-pull system appears, because hum voltages in the two tubes are in phase and therefore their fundamentals and odd harmonics cancel in the output. The result is a much quieter amplifier than is possible with a single tube.

The Type L Special B-C Current supply giving 425 volts to one UX210 power amplifier tube allows an output of 1500 milliwatts. Using the Type LL Special B-C Current Supply giving 425 volts to two UX210 push-pull in the Universal Transoceanic specially equipped for push-pull amplification, an undistorted power output of 7 to 9 watts. The Universal Transoceanic is equipped with two volume controls, the radio frequency rheostat control allows an adjustment to prevent overloading the detector and the second volume allows adjustment to prevent overloading the power tube, this arrangement making an ideal combination.

The full wave "B-C" current supply type LL has sufficient output to also supply the necessary 100 volts 40 milliamperes to excite the field of a Dynamic Loud Speaker. In an ordinary cone loud speaker the distance between the armature and the pole pieces is made small in order that the loud speaker will be sensitive to weak signals. How-

**POWER AMPLIFIER LAYOUT FOR USING UX-210 TUBE
WITH ACME BH-1 TRANSFORMER**

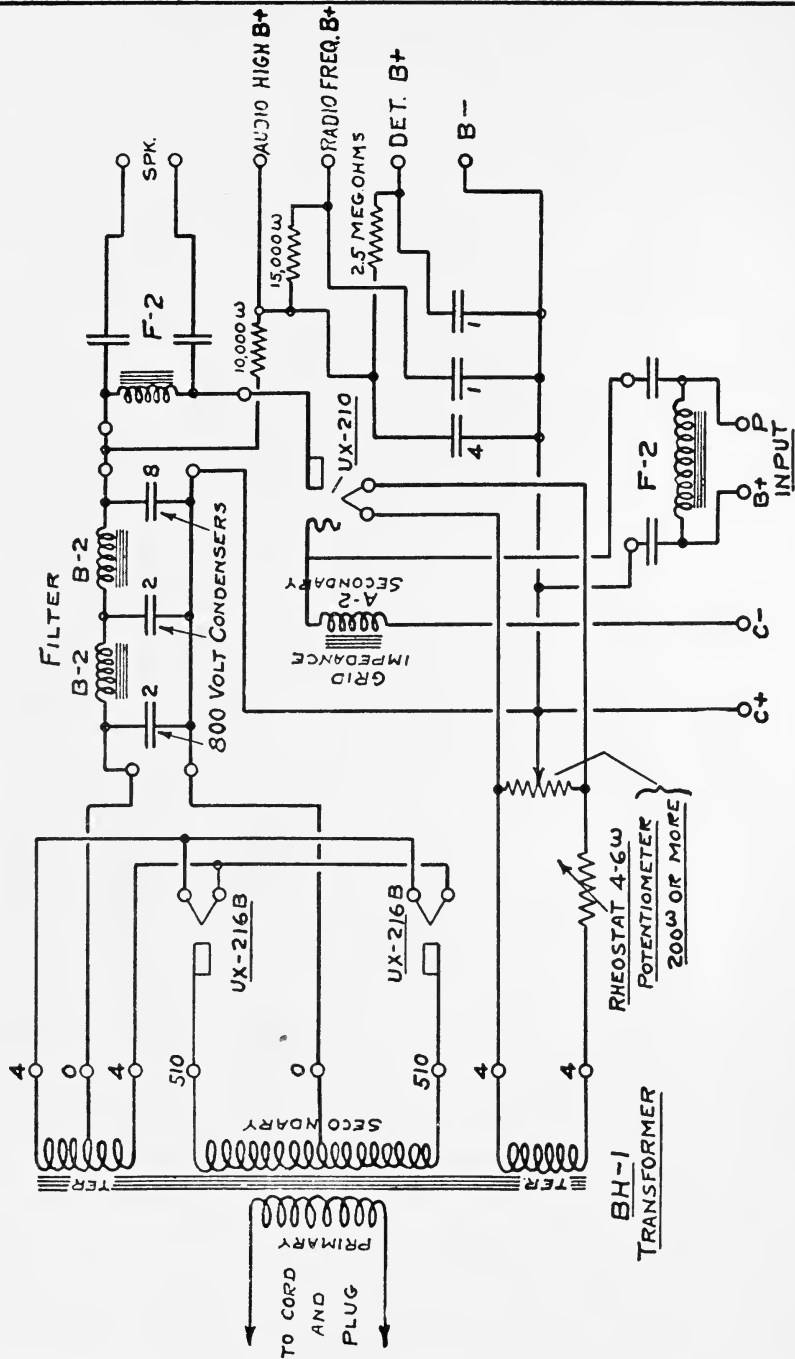

Fig. 151

ever on strong signals there is so great an armature movement that the armature strikes the poles pieces causing distortion. In a Dynamic, the permanent field pole pieces are replaced by an externally excited magnetic field centered around a cylindrical pole. The armature is directly over this pole, concentrically and can move backwards and forwards without striking anything. Accordingly the armature can be subjected to extremely strong signals without distortion. The Dynamic speaker is the coming speaker where maximum volume without any distortion is required. Where a current supply of 100 volts, 40 milli-amperes is not available the Dynamic speaker is available with the magnetic field winding arranged to draw $\frac{1}{2}$ ampere from a six volt direct current supply (filament A Battery or A Eliminator).

The mechanical and electrical construction of the Special B-C Current Supply is very substantial throughout. It may be operated to full capacity continuously without undue overheating. The primary supply current is usually 110-volts, 10-cycles. By using a special transformer it can be supplied for operating from 25, 40 or 50 cycles and any special voltage. The power transformer steps up the supply voltage from 110 to 525 volts. This is rectified and passed through two filter chokes. As the power tube plate current is not amplified, it does not have to be as finely filtered as the other supply voltages and accordingly the high voltage tap is taken off after the first filter choke. This is done to save a drop in voltage across the second choke which would be lost. In addition to the two filter chokes there are three filter condensers totaling 8 microfarads as shown in the diagram. In the latest models there is still another 8 MF reservoir condenser across the high voltage, to keep the output voltages from "fluttering" or "motor-boating" under full load.

A large resistance having a total of approximately 40,000 ohms is used as a voltage divider, the top being the positive terminal of the total d.c. voltage available and the bottom being the negative terminal.

Instead of using the bottom as the B negative common terminal, the B negative common terminal is moved up the resistor 40 volts and the lower end of the 40 volts used as the negative bias terminal for the power tube.

Another method of obtaining the bias voltage is sometimes used and consists of placing a suitable resistance in series with the power tube filament return lead. This system has the advantage of enabling the use of a resistor having a much smaller current carrying capacity, as only the power tube plate current passes through this resistance and not the total B current consumption as in true in the first method.

When a UX200 detector tube is used, the voltage from Supply No. 1 can be regulated to the desired value, approximately $22\frac{1}{2}$ volts.

However, the UX200 or CX300 detector is so critical to plate voltage variations that the least variation in any of the other current values will add or subtract to the detector plate voltage. A voltage regulating device would not hold the voltage steady enough for this tube and a separate B battery of $22\frac{1}{2}$ volts is recommended. This battery only supplies one tube and would have a life of one year and is not in any way an objection. In Universal Transoceanics built especially for a UX200A detector tube, the Current No. 1 Supply can be used for the detector plate voltage if the receiver is not used to extreme sensitivity. Where maximum distance reception is required a separate detector voltage of $67\frac{1}{2}$ volts is recommended. When a UX200A detector is used a heavy piece of felt or soft rubber should be placed between the tube and the shielding compartment to take up mechanical vibrations, this in turn preventing the amplification of disturbances from microphonic tubes.

Trouble with the Current Supply due to lack of voltage output is usually always due to a defective rectifier tube (216B or 281), this type of tube will occasionally fail for various reasons. The indication of tube failure is only low readings on the receiver voltmeter or no readings at all. Occasionally one of the three Supply adjusting resistors will get out of order and this is indicated by a lack of voltage at the circuit the device feeds, No. 1 detector circuits, etc. Trouble with any of the other parts is practically unknown, it is impossible to overload or damage the power transformer unless a wrong connection is made externally, and the connections should be very carefully checked before placing the instrument in operation.

The leads from the Current Supply to the receiver should be as short as possible and they should not be bunched together as a cable. Any unused lengths of connecting wire should be cut off in order to make the leads short and neat.

WHAT GOVERNS THE POWER HANDLING CAPACITY OF AN AMPLIFIER

As the novelty of radio has gradually disappeared, and more interest is taken in it purely as an instrument to reproduce with fidelity both music and speech, the listener and engineer have given more and more thought to the tonal qualities of the broadcast receiver. The vast radio audience today is first of all concerned in how well it can hear. How far is a secondary consideration.

It would seem to the average listener inexperienced in radio experimentation that all that is necessary to increase volume is the addition of a stage or two of audio frequency amplification of his existing equipment. This is true to a certain extent, but as we are interested

only in *QUALITY VOLUME*, the design of the apparatus used in the "stage or two" of audio frequency amplification is of great importance.

A speaker, which does the actual reproducing of sound, is an energy operated device and as the energy is derived from the last audio tube alone, the undistorted volume obtainable from a speaker is wholly dependent upon the energy output of this tube and no other. The energy is measured in milliwatts and the following table gives the power output of the tubes now in common use, with the plate voltage necessary to obtain full output:

Tubes	Undistorted Output	Plate Voltage
UX120	110	135
UX226	160	180
UX112	195	157
UX171	700	180
UX210	1500	425

In order to secure the maximum power output that a tube is capable of delivering, it is necessary that a sufficiently large voltage be placed on the grid of the tube to operate at its maximum output. At the same time certain conditions, however, must be satisfied to prevent distortion in the tube itself. First, the grid must not be allowed to become sufficiently positive to draw any appreciable amount of grid current, and second, the plate current must at no portion of the cycle be allowed to fall so low that distortion be caused by curvature of the plate current curve. The input voltage which may be applied safely to a tube without causing grid distortion is fairly well indicated by the grid bias voltage. Actually the effective grid swing permissible in volts R. M. S. is $\sqrt{2}$ or .707 times the grid bias.

2

The solution of the problem of *QUALITY VOLUME* is threefold, embracing tubes, transformers and speakers wherein distortion of various sorts and causes tends to develop. It may be well to state here that there are two apparent forms of distortion to guard against in any audio amplifier: frequency distortion and waveform distortion. Frequency distortion, which really is not distortion at all, but the relative differences in the amplification of different frequencies is caused by one of two things, either a coupling device that is not capable of even performance over the audio range, or the improper matching of impedances of the different circuits. It is extremely important from a frequency viewpoint that the impedances of the various circuits bear a definite relation to each other. To secure a maximum transfer of

voltage from one circuit to another (and we are interested in this respect only in voltage and not in energy), the impedance of the transformer primary should be at least two or three times that of the tube circuit at the lowest frequency which we wish to amplify. Waveform distortion in the amplifier itself is caused by either an over-loaded tube or saturation of the core of the audio transformers. With the present-day standards of transformers, however, the latter from a practical standpoint may be entirely disregarded. Obviously the remedy for an overloaded tube is the reduction of the input signal or the increase of grid bias and plate voltage, thus permitting the tube to be worked on the straight portion of its grid voltage plate current curve.

Assuming one to have an audio amplifier and tubes of the standards of two or three years ago, the most radical improvement in quality would be brought about by the replacement of the last audio tube by one of the new power tubes, such as the UX171 or UX210. This would increase the power of handling capacity of the amplifier 50 to 100 times and this power handling capacity of an amplifier is something that is not very well understood by the average man, yet it is extremely important if faithful reproduction is to be obtained. In order to produce the same intensity to the ear, say at 60 cycles, many times as much power is required as at 1000 cycles. A somewhat disconnected yet fitting illustration would be the comparison between a Tuba player and a Cornet player in a brass band. The Tuba player expends much more energy, but to the ear the Cornet is louder. In the case of the loud-speaker far greater power is needed to supply the energy than was heretofore thought necessary to reproduce bass notes properly, and it is even very doubtful if the tubes on the market today are capable of supplying to the speaker enough energy to reproduce these low frequencies, with the same intensity as the higher frequencies, unless a 50 or 100 watt power tube is used. This would require a type of plate supply device, which from an economic point of view, would be entirely out of the question.

While it would seem that increasing the energy output of an amplifier would result in extremely loud reproduction, this is not necessarily true. A loud sound may be doubled in intensity—that is, the energy doubled—and the ear may hardly detect the change. This fact will explain in some measure why many people are not able to note the difference in the volume produced by a UX171 and UX210 tube, although the maximum output of the UX210 is double that of the 171. Everything else being equal, the reproduction, when using the UX210, should appear much better on the lower frequencies—actually it is about the same, because the lower plate impedance of the 171

permits a greater transfer of energy from tube to speaker at these frequencies.

The power handing capacity of an amplifier using present day transformers is more or less limited by that of the tubes used, since the largest possible portion of the negative side of the grid voltage plate current curve is available for the actual plate voltage used. While resistance or straight impedance coupled amplifiers are better from a purely frequency standpoint, the power handling capacity is decidedly limited, as there is a certain rectifying action of a strong signal caused by the time action of the grid condenser and leak, and their purpose, even from a frequency standpoint, is often defeated by the improper use of tubes. A man will quite frequently pay from \$10.00 to \$20.00 for an impedance coupled amplifier only to use a 201-A tube in the last stage, and it is very doubtful if the improvement in quality in this case is even noticeable to the ear. This is only another example of insufficient power required to reproduce bass notes, although the frequency characteristic of an impedance or resistance coupled amplifier is essentially a straight line from 30 cycles upward. A very interesting laboratory experiment along these lines proved that where a pure 60 cycle note from a vacuum tube oscillator was fed directly into the grid of a UX210 tube, the full output of this tube did not produce even an audible sound at this frequency. All low frequencies are not entirely lost, however, as their harmonics are reproduced, but with much less intensity, and the fundamental pitch is usually obtained by the beat note of a second and third harmonic.

In reviewing the subject of power handling capacity of an amplifier, there are many other more important phases to consider than the particular method of coupling (transformer resistance, or impedance). It is a well-known fact that no better quality can be expected than is radiated from a broadcasting station or that can be faithfully reproduced by the loudspeaker—regardless of what coupling method or combination of methods may be used.

Bearing in mind that the frequency range of the better broadcasting stations is something like 80 cycles to 5000 cycles, and the better loudspeakers cut off at 80 cycles at the lower end and 7000 cycles at the upper end, also remembering that the better transformers in use today are capable of even amplification between 60 cycles and 6000 cycles the selection of the amplifier tubes and proper operation for maximum efficiency of those tubes should receive more consideration than is generally given to amplifier tubes, particularly the last stage tube from which the loudspeaker is operated.



Fig. 152

UNIVERSAL PLIO-6

The Universal Plio-6 is of particular interest as it was the first tuned radio frequency receiver to have a wavelength range of from 35 meters to 3600 meters. This provided a receiver which was not only suitable for broadcast reception in this country but also suitable for use in any of the foreign countries. On the European continent and several other foreign countries, wavelengths up to 2600 meters are used for broadcasting. Furthermore as the receiver tuned down to 35 meters it was suitable for the reception of short wave programs as broadcasted from the United States to all points of the world. This model is now in use in practically every country in the world.

The accompanying photographs illustrate the 1928 model. The receiver consists of two tuned radio frequency stages, a detector stage and three stages of audio frequency amplification. The tuned radio frequency transformers are mounted on removable bases and sockets so that they can be instantly changed, the process being similar to changing tubes in a socket. The transformers which accompany the receiver are type A and cover from 200 to 560 meters (the regular broadcast band in this country). The extra transformers obtainable for this receiver are as follows:—

Type B	Tuning from	80 meters to	210 meters
Type C	“ “	35 “ “	90 “
Type BB	“ “	1200 “ “	3600 “
Type AA	“ “	500 “ “	1200 “

By utilizing Hogan Patent 1,014,002, two of the tuning variable condensers are combined on a single shaft, this reduced the total tuning adjustments to two. That is to tune from one wavelength to another it is only necessary to tune two dials. To provide for any differences in values of the two condensers moved by one shaft, over the entire dial range, a small vernier condenser is connected across one of the two condensers. Normally this vernier condenser is in a neutral or center position and can be moved either left or right to add or subtract from the large condenser to make the two circuits match. This adjustment is only required for fine tuning on extremely weak signals or for short wave work.

When using the Type A transformers, the two radio frequency stages have series grid resistors in series with the radio frequency amplifying tubes to prevent oscillations or regeneration. However, when the Type C Transformers are used, these series resistors are not required and the transformer bases are so wired that the resistors are automatically cut out of circuit when the C coils are inserted in place of the Type A.

As the receiver is non-regenerative it is not suitable to receive continuous wave signals without an external source of oscillations. A separate oscillator such as the General Radio Co.'s radio frequency oscillator should be used for this purpose.

The receiver is specially designed for use with the UX200 detector tube, but can be supplied on special order for use with UX200A detector or for use with AC tubes. Provision has been made to use a power tube in the last stage, either a UX112 or UX171 or similar power tubes, leads being available to insert the necessary bias battery and to apply the proper plate voltage. Best results are obtained using UX222 tubes for the two radio frequency stages.

The audio system has been made in several different combinations since 1924. The original audio system consisted of three transformer coupled stages. Later this was changed to two transformer stages and one resistance coupled stage. With Hi-Mu tubes now available it is possible that the latest sets will have only one transformer stage and two resistance coupled stages, or even three resistance coupled stages.

Having only two tuned radio frequency stages, the receiver is not selective enough to tune out nearby local stations of great power and tune in distant stations only separated by 10 kilocycles. It is, however, plenty selective enough to separate all local stations clearly. The receiver is very sensitive and a range of 3000 miles from average locations is not unusual. Two rheostats are provided, one on the radio frequency tubes to control the volume and one on the detector tube to control the sensitivity of the detector action.

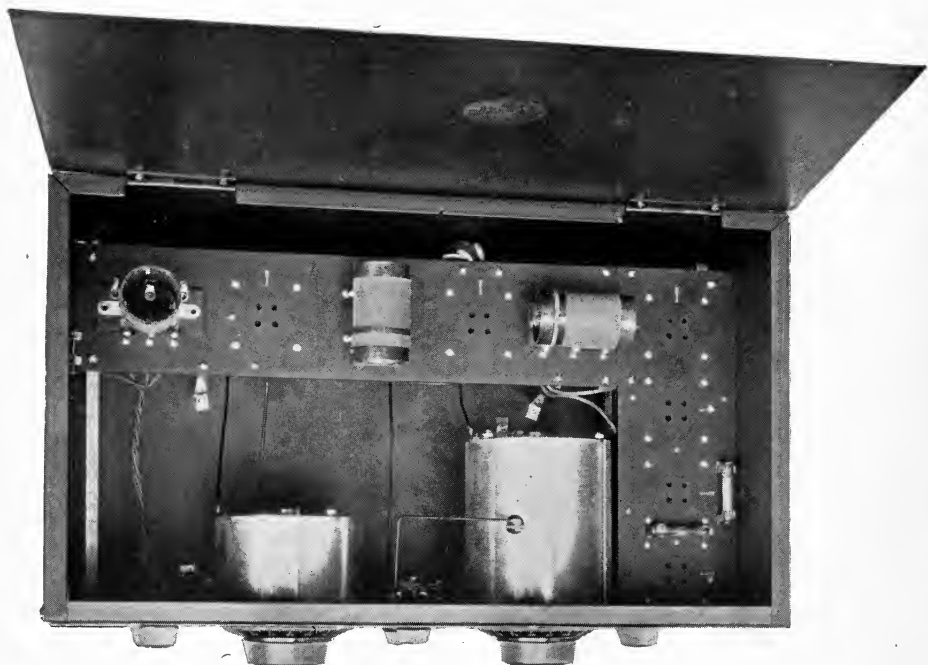

Fig. 153. Universal Plio-6.

IMPERIAL MODEL UNIVERSAL SUPER-8

The Imperial Super-8 is a receiver similar to the Universal Plio-6 but of more elaborate design and having many refinements. There are a total of seven tubes divided as follows: two tuned radio frequency amplifiers, detector and four audio frequency amplifiers. There are two main tuning controls, one single condenser tuning the first transformer and one double condenser tuning two circuits simultaneously. These tuning controls are fitted with pointers indicating on large engraved scales. The adjustments are made through a small knob which operates a pinion and in turn drives a large gear, providing a fine adjustment.

A rheostat is provided for the detector tube, the other tubes have their filament values fixed at the proper values with fixed resistors.

A special antenna coupling circuit is provided to enable the receiver to tune over a wide wavelength range with maximum possible efficiency and with good selectivity. This circuit consists of an antenna series condenser continuously variable from a very small minimum to a maximum capacity of .00025 MF. At the extreme maximum position the condenser automatically short circuits its self out of circuit.

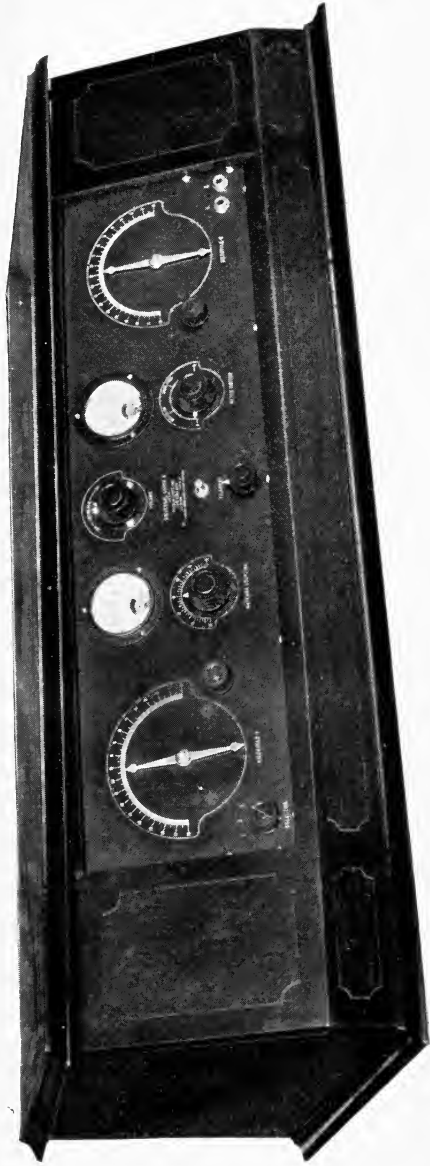

Fig. 154. Imperial Super-8.

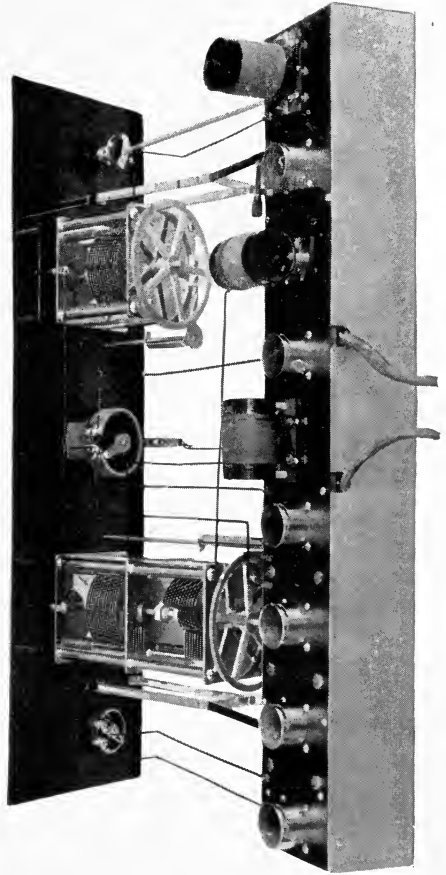

Fig. 155. Internal View Super-8.

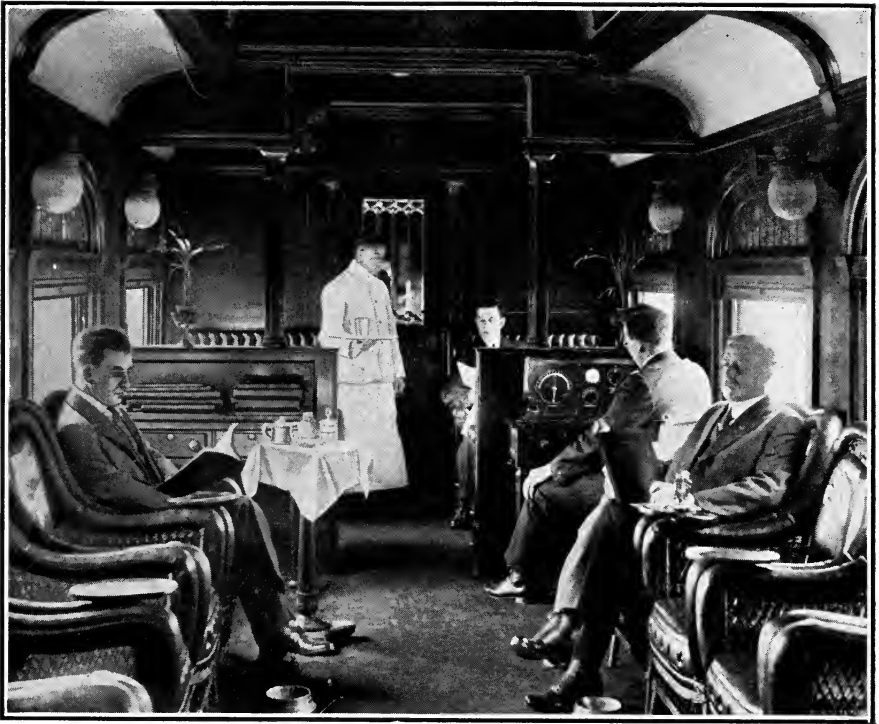

Fig. 156
Universal Super-8 Railway Dining Car Installation.

The condenser is actually right in series with the antenna and using an ordinary antenna, the total capacity of the antenna circuit can be reduced by reducing the capacity of this variable condenser; an increase in selectivity being obtained with decrease in total capacity. This condenser works in connection with the selector switch on the antenna inductance. This selector switch provides three degrees of coupling between the antenna and the antenna inductance, low, medium and high, corresponding to points, 1, 2 and 3. When tuning to wavelength around 450 meters greater coupling between the antenna and antenna inductance is required than when in tuning in the vicinity of 200 meters. However, it must be remembered that an increase in coupling usually results in a decrease in selectivity. From the above it will be noted that with the coupling condenser at zero and Selector switch at position 1 that maximum selectivity is obtained with minimum signal strength. On the other hand with the coupling condenser at 190 degrees and the selector switch at position 3, maximum signal strength is obtained

with minimum selectivity. During operation positions between these two extremes are selected to suit local conditions and the various wavelengths received.

The receiver is usually supplied for UX200 detector but can also be obtained for use with a UX200A. The audio amplifier of four stages has coupling units depending upon the conditions under which the receiver is to operate. For example if the B voltages available were limited to 135 volts, it would be preferable to use two transformer coupled stages and two resistance coupled stages. If 180 volts were available for the B supply and 400 volts for the power tube, it would be best to use all resistance coupled stages, using high- μ tubes.

The speaker windings as plugged into the receiver jack, are protected by an impedance and condenser. It must be remembered that when an impedance and condenser filter are used to protect the speaker windings that this filter only isolates the current and not the voltage. Using this system and high voltage it is possible to get a shock from the speaker frame (if metallic) and other parts of the receiver circuit. Using 400 volts it is well to have the speaker terminals in the rear of the receiver or use a jack plug which is entirely insulated.

When using a receiver which has resistance coupled audio stages on a small B battery eliminator there is usually the difficulty of "motor-boating" or "fluttering," that is the current supply is not steady enough or of sufficient current capacity to give stable operation. This can be corrected in several ways. One method is to use much larger resistances in the plate coupling circuit, instead of having 100,000 ohms in the plate circuit, $\frac{1}{4}$ or $\frac{1}{4}$ megohm could be used. The second method is to place a large reservoir condenser across the B battery eliminator. An extra condenser of 8 MF is usually sufficient and should be connected from negative B to positive B at the eliminator.

All the audio and radio frequency parts directly connected with the tube sockets are mounted underneath a long tube shelf. This shelf is covered below with a shielded case which not only provides some desirable shielding but also protects the delicate parts from moisture and dust.

MODEL C SUPER-HETERODYNE

The model L Super-Heterodyne was the first super-heterodyne receiver developed and marketed for broadcast radio reception, it is the basis circuit of all subsequent super-heterodynes marketed under different names. It was the first receiver of the super-heterodyne type exported to all the principal foreign countries of the world for broadcast reception. It was a very successful design and at the time of intro-



Fig. 157
Improved Model C-7 Super Heterodyne.

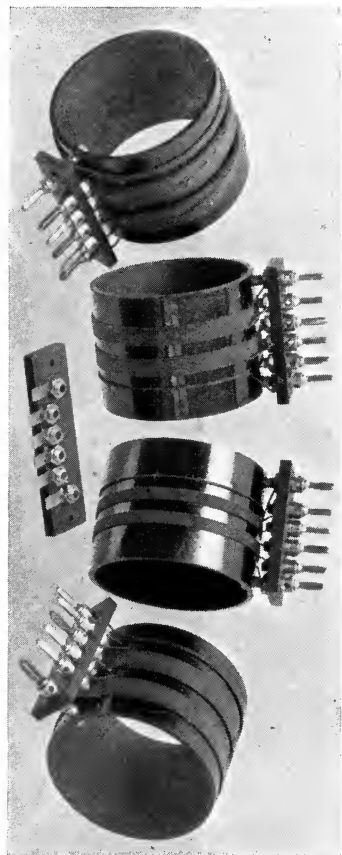

Fig. 158
Interchangeable
Oscillator Couplers for Model
C-7 covering 20 meters to
600 meters.

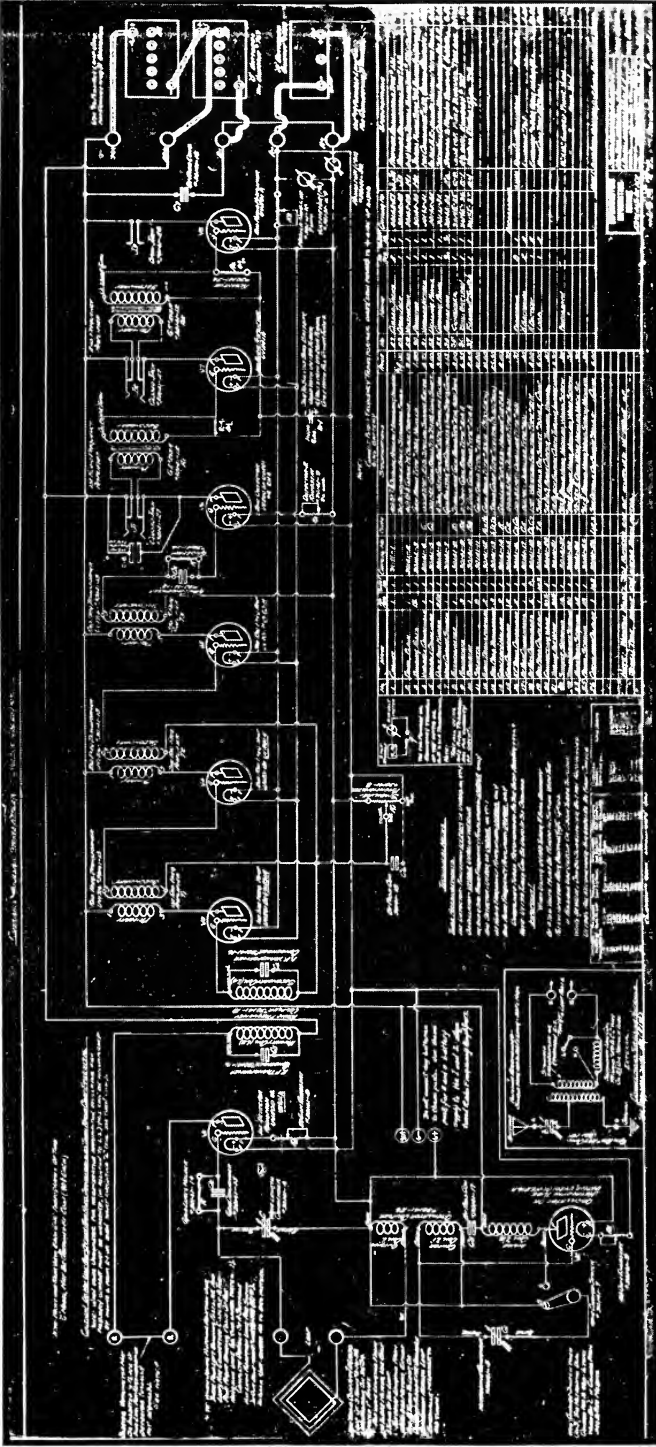

Fig. 159
Schematic Wiring Diagram of the Original Model C,
eight tube Super-Heterodyne.

duction was the most powerful and selective radio receiver made. By referring to the advertising files of magazines (1922-1924) the above facts are confirmed and it will also be noted that the nearest competitive receiver is the regenerative type having only three tubes compared with ten in the model L.

The Super-heterodyne method of reception has many advantages and also has some disadvantages. The advantages by far exceeded the disadvantages in the early days of broadcast reception. The coming demand for super-heterodyne receivers will be for the reception of signals on wavelengths lower than 200 meters as below these wavelengths the efficiency is considerably greater and the system more flexible than straight tuned radio frequency amplification. Allowing a band of 10,000 cycles for each broadcasting station it will be realized that there is room for 600 different transmitting stations, each on a different wavelength, compared with room for 50 stations, between 300 and 600 meters. The short wavelengths have greater carrying ability which has been demonstrated by performance of the short wave transmitters of WGY, KDKA, WLW and others. The musical programs transmitted from these stations are heard regularly in all parts of the world, practically day and night. The short wave transmission is subject to "fading" and "swinging" of signals but undoubtedly this will be overcome in due course.

Using ordinary tubes, it is possible to obtain more radio frequency amplification per stage on the high wavelengths than at the low wavelengths, in an untuned or tuned radio frequency amplifier. Accordingly instead of tuning in a signal at say 150 meters and building up this signal with tuned radio frequency stages, each tuned to 150 meter; the super-heterodyne system tunes the signal in at 150 meters, combines the signal with a local oscillator and changes the wavelength to a higher value of approximately 10,000 meters and carries on the radio frequency amplification at that wavelength. After the desired amount of radio frequency amplification is obtained through successive stages, the signal is rectified by a second detector and amplified at audio frequency by additional tubes to feed a loud speaker. The change in frequency to carry on the amplification at a higher wavelength, through the use of a local oscillator is obtained without any distortion due to the local oscillator.

The complete system is divided into the following sections:

1. Antenna or loop circuit for collecting the signal and means of tuning same to the desired signal wavelength.
2. 1st Detector Circuit and means for tuning same, if directly coupled, this can be obtained with the antenna tuning.

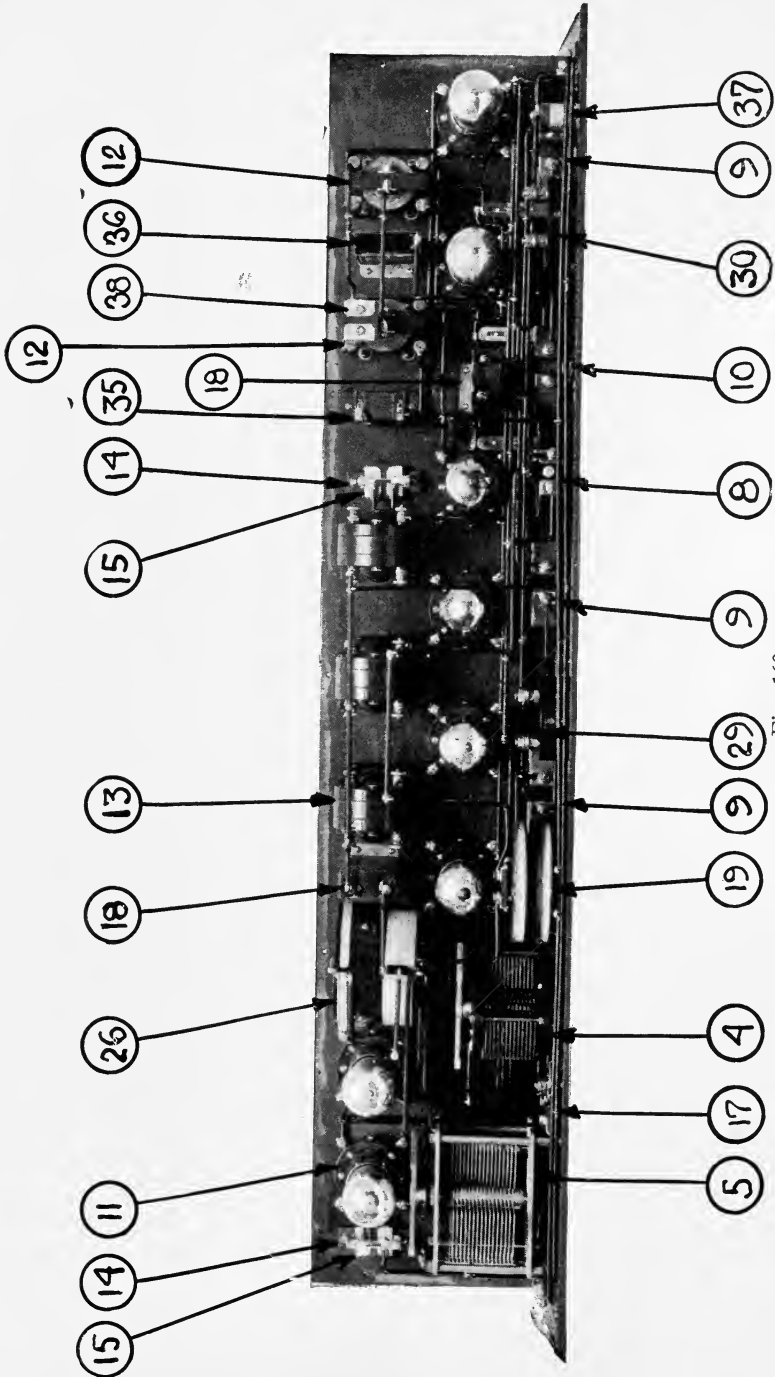

Fig. 160

Interior Plan View Model C Super-Heterodyne

3. Local oscillator and means for varying the frequency or wavelength so that the incoming frequency can be changed from its high value to a lower value more suitable for radio frequency amplification.
4. An efficient radio frequency amplification to carry on the radio frequency amplification at a low frequency.
5. A 2nd Detector to rectify the radio frequency signal into an audible signal.
6. An audio amplifier, which can include a power tube to provide loud speaker signal strength.

The accompanying cuts illustrate the Model C fully constructed and the wiring diagram of the receiver. The change in frequency obtained is due to the plain heterodyne action. For example if two separate oscillators are to be tuned to exactly the same frequency they are in resonance and there is no unusual action. However if the two oscillators have different values a third oscillation will be set up, known as a heterodyne, the value of which will be the difference in frequency of the two original sources of oscillations.

A good example of this action is the present day broadcasting conditions. Two stations are supposed to be each transmitting on 790 kilocycles, however, one station is on 789 kilocycles and the other station on 791 kilocycles. The difference is 2000 cycles and a note or whistle of this frequency is heard when tuning to either of the two stations. One station may be close by and the other at a distance. The program of the nearest station will drown out the program of the distant station on practically the same wavelength, yet the carrier frequency of the distant station will interfere with the local program. Besides the main frequencies heterodyning or beating, the harmonics of one oscillator may be at values which will heterodyne with the main frequency of a second oscillator. For example there are two stations in the vicinity of New York one operating on 710 kilocycles and the other on 1420 kilocycles, one is a little off and there is an interfering heterodyne whistle.

The eight tubes of the model C are divided into the 1st Detector, Local Oscillator, three intermediate radio frequency amplifiers, 2nd detector, two audio amplifiers. During the change in frequencies, a gain in signal strength is obtained, known as the heterodyne amplification which is one advantage of this system. The first detector can also be arranged to oscillate, combining the detector and oscillator as one tube but for best results this is not desirable. Regenerative amplification can be added to the detector circuit and this feature was incorporated in the Model C7 which later superseded the model C. By keeping

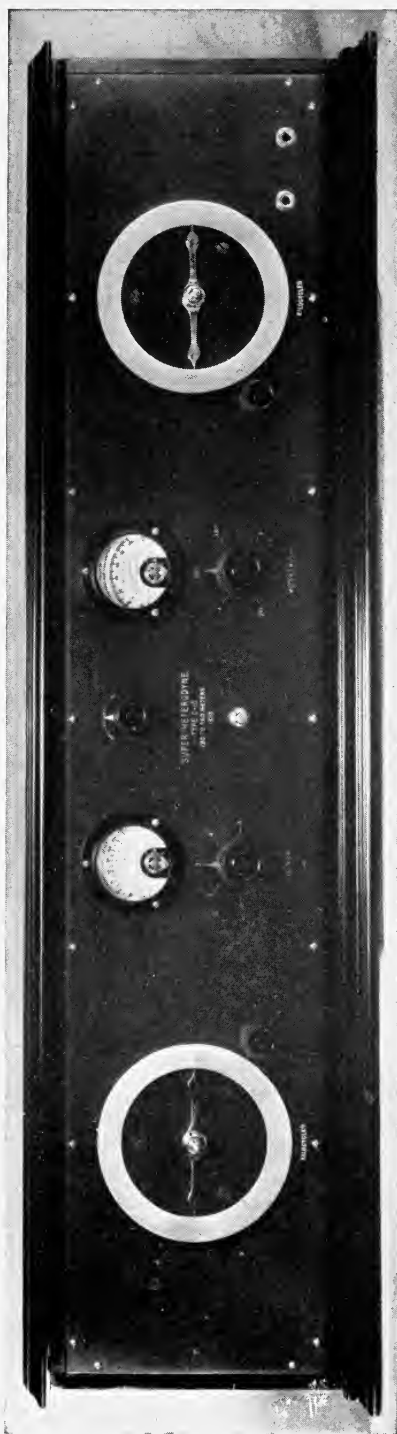

Fig. 161
Model C-10, Front View.

the first detector just below the oscillating point, the signal collected by the antenna or loop was giving a considerable gain before the frequency was changed for the radio frequency amplification.

The intermediate amplifier of the super-heterodyne should not be in an oscillating condition for the reception of spark signals or musical programs. The problem of neutralizing the intermediate amplifier is relatively simple as the amplifier only has to be set for one particular wavelength, in this model 10,000 meters. The system of preventing oscillations in this model consisted of a potentiometer across the A battery, the center arm of which was run to the grid returns of the radio frequency amplifier transformers. Oscillations were prevented by moving the potentiometer arm toward the positive side of the line moving the potentiometer toward the negative increased the amplification until the limit was reached. Other up to date methods may be used if desired. The use of the UX222 would be ideal.

In an ordinary super-heterodyne the oscillator has two tuning points for each wavelength. These two points correspond to adjusting the oscillator to either above or below the difference in frequency desired compared with the signal frequency. For example to change 400 meters (750 kc) to 10,000 meters (30 kc) the oscillator could be set to either 780 kc or 720 kc. This is one of the disadvantages of the super-heterodyne. Harmonics of the oscillator will also heterodyne through a signal which may also be undesired.

Furthermore the antenna or loop collector is full of oscillations of different values originating from nearby oscillating receivers, other super-heterodynes, and carrier waves. Tuning the oscillator dial over its range, the main frequency and harmonics heterodyne with all these undesired oscillations which causes a continuous series of whistles. This undesirable condition in a super-heterodyne is only eliminated by the C-10 model which has three stages of tuned radio frequency amplification preceding the super-heterodyne system. The function of these additional stages is not only to build up an extremely weak signal, but to filter out effectively all undesirable carrier waves and other parasitic oscillations picked up by the antenna. The Model C and C-7 would be suitable in distant countries but only the C-10 would be suitable for present day broadcasting conditions.

A super-heterodyne system has been devised where the frequency is increased instead of decreased. This does not provide any means of great radio frequency amplification but does provide some increase in selectivity and reduces to the oscillator tuning points from two to one. There are really two oscillator tuning points, but they are so close together they cannot be noticed.

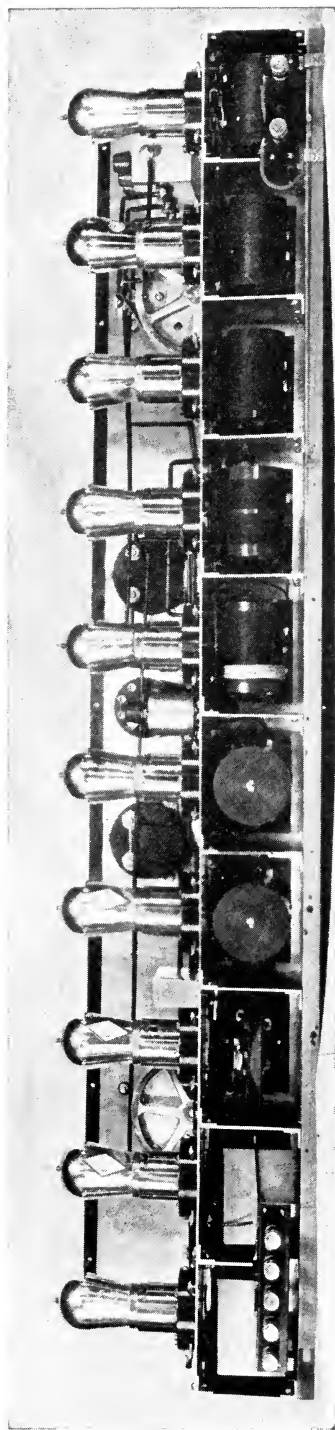

Fig. 162. Model C-10 Rear View, (Cabinet removed).

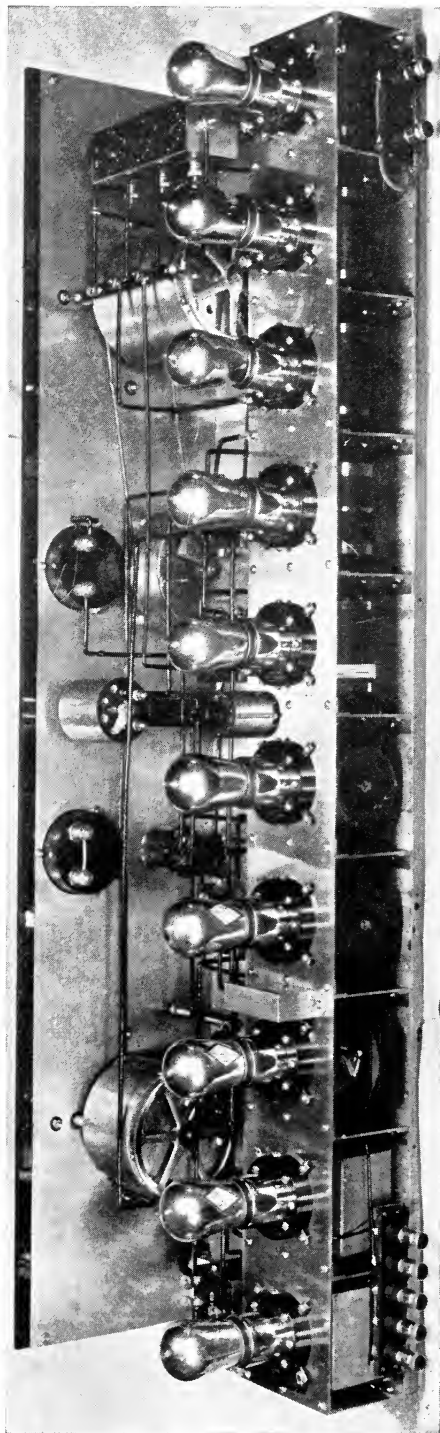

Fig. 163. Rear angle view Model C-10 Super-Heterodyne.

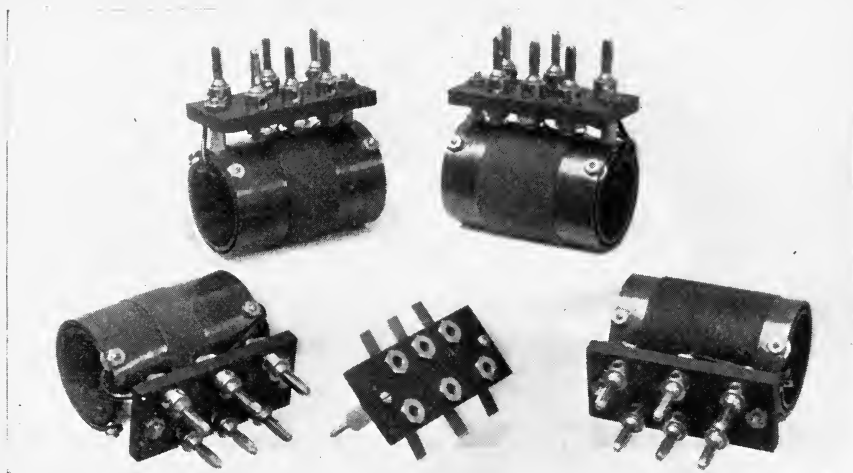

Fig. 165

Interchangeable Tuned Radio Frequency Transformers for C-10 Super-Heterodyne.

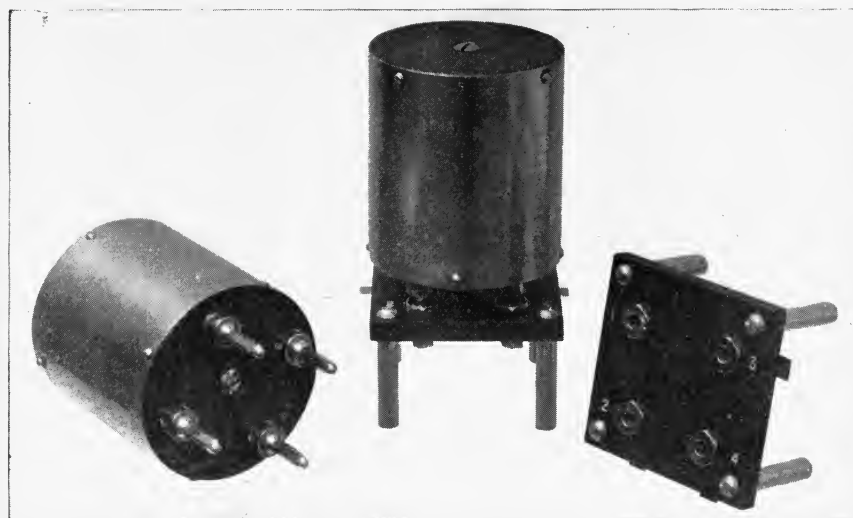

Fig. 166

Intermediate Radio Frequency Transformers for Model C-7 Super-Heterodyne.

In some models where the intermediate amplifier works at 10,000 meters, iron core radio frequency amplifier transformers are used. Great care in the selection of an iron core radio frequency must be taken. Improperly designed transformers of this type amplify at audio frequencies as well as at the radio frequencies adding considerably to the total static received with the signal. It seems that any way the super-heterodyne method of reception is much noisier than straight tuned radio frequency amplification. This may be due to the fact that static is received on two wavelengths as compared with one in the tuned radio frequency set. It is a well known fact that the static disturbances increase with increase in wavelength, generally speaking.

The Model C-10 Super-Heterodyne was developed in early 1924 and at that time was the last word in broadcast receivers and probably is still today the best super-heterodyne receiver for broadcast reception. The C-10 design was the results of the desire to bring the Model C to a point to keep up with the modern changes in broadcast transmitters. The principal requirement was maximum selectivity and the second feature a wider wavelength range, particularly for the short wavelengths.

The ten tubes in the C-10 are divided as follows:

- 1, 2, 3, Direct Tuned Radio Frequency Amplifiers.
- 4, Local Oscillator for Heterodyne Action.
- 5, 1st Detector (Regenerative).
- 6, 7, Intermediate Radio Frequency Amplifiers.
- 8, 2nd Detector.
- 9, 10, Audio Amplifiers (10 would be the power Amplifier.)

The radio frequency amplifier requires four tuned circuits and to simplify tuning, three of the tuning condensers are mounted on a single shaft for simultaneous control. The antenna tuning condenser is left independent for fine adjustment and added selectivity. The oscillator condenser control is of course individual. This means three different controls must be tuned to change from one wavelength to another. The three controls could be reduced to one with mechanical arrangements but there would be a loss in efficiency.

The tuned radio frequency transformers and oscillator coupler are of the removable type, fitted with plug-in bases and sockets. The main set of transformers covered a wavelength range of about 220 meters to 560 meters. Additional sets of transformers were available which enabled tuning down to 50 meters.

The intermediate transformers were also of the plug-in type but not for a change in wavelength. The idea was to facilitate testing,

enabling the engineer to try different transformers to match them up in actual operation for maximum efficiency together with proper selectivity.

A complete system of shielding was employed through out the receiver. In the first place the entire inside surfaces of the cabinet and back in the front panel were covered with sheet copper. The copper was nickel plated to a satin finish for pleasing appearance. This insured that practically everything picked up by the receiver had to come through the antenna circuit and not directly into inductances in the middle of the receiver. The ten tubes were mounted on a brass tube shelf, this tube shelf being divided underneath into ten compartments, one for each of the five tuned transformers, one for each of the two intermediate transformers, one for the output coupler and one for each of the audio transformers.

The accompanying illustration gives the circuit diagram and the other photographs give a fine idea of the advanced construction. One Voltmeter is provided with a multiple point meter switch to read the essential voltage readings. The other meter is a Thermo-galvanometer to read the oscillatory current in the oscillator circuit.

The multiple condenser consisting of three condensers on a common shaft is equipped with an auxiliary fine adjustment device consisting of three small vernier condensers. These small vernier condensers are enclosed in a shielded case. The three condensers of the multiple condenser are shielded from each other by barriers between the stators. The entire condensers are shielded by an enclosing brass cover. All the brass work is nickel plated. The triple condenser and antenna condenser are connected together mechanically by a band and two pulleys of the friction type. Moving the triple condenser moves the antenna in the same relation, however, if the antenna is to be moved individually, this is possible by holding the triple condenser in place while adjusting the antenna condenser knob.

Even the bias batteries are contained in small shielded containers, and the detector grid leak (second detector) will be seen contained in a shielded box.

The variable condensers, triple, and single for oscillator are easily adjusted through the main gear and small pinion provided. The main gear is brass, but the small pinion is fibre, this preventing any noise or scratching during operation. All tubes are provided with fixed resistors setting them to their proper filament values. The volume is controlled by a resistance, variable by steps, connected across the first intermediate radio frequency transformer.

As this receiver was designed nearly four years ago, a few improvements could be improved to bring it up to date. It would be a decided advantage if the last audio tube was rewired for a UX210 power tube, supplying the filament with $7\frac{1}{2}$ volts a.c., the grid with 35 volts bias and the plate with 400 to 450 volts. An output transformer or filter and condenser provided to isolate the power tube plate current from the speaker windings. Two low ratio audio transformers of high quality performance could be added to advantage. This and using UX222 tubes for the radio frequency amplifiers is all that could be done to improve the receiver up to the present time. If the power tube was installed in the last stage a suitable B-C Current Supply should be used.



Fig. 167

Universal Plio-6 with Mahogany Cabinet.

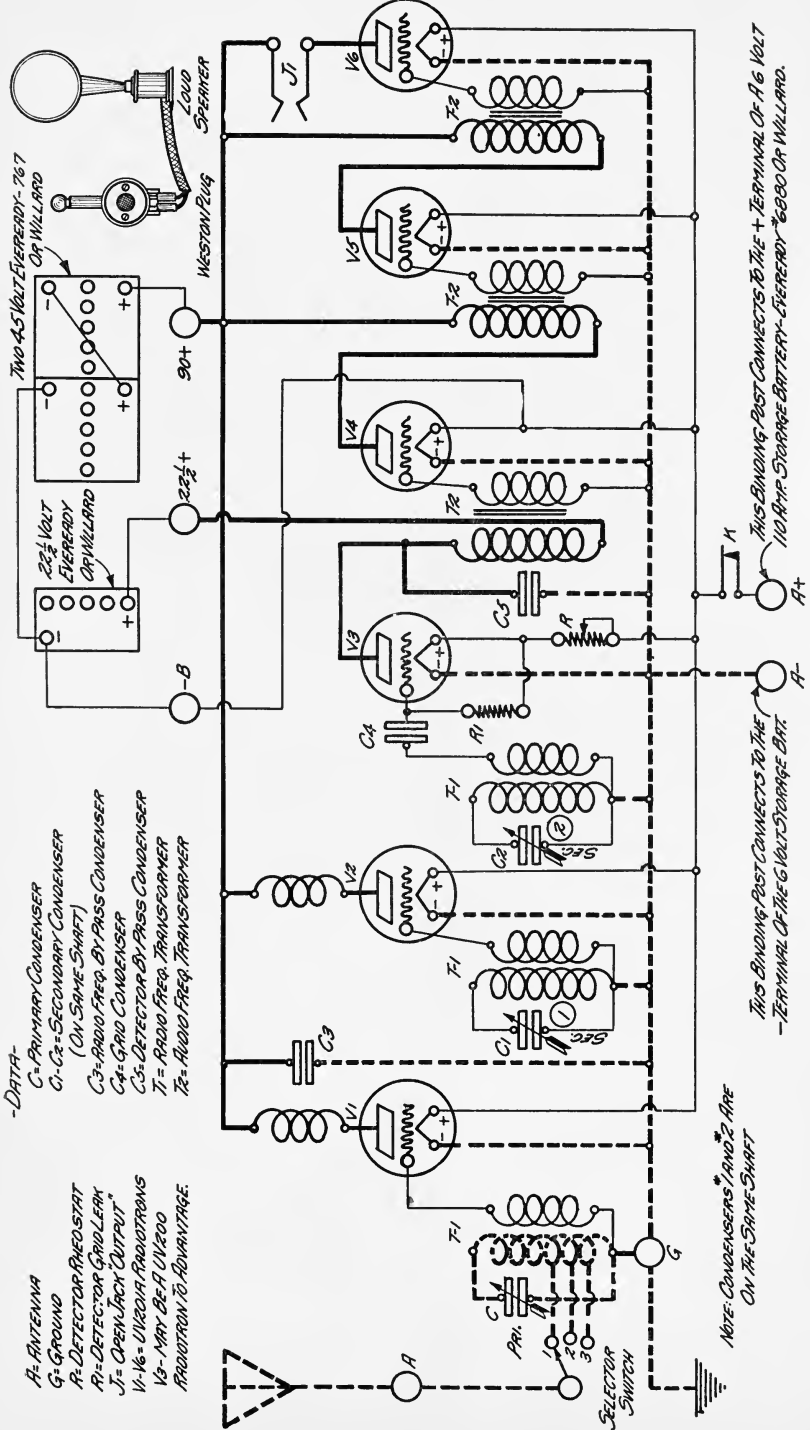
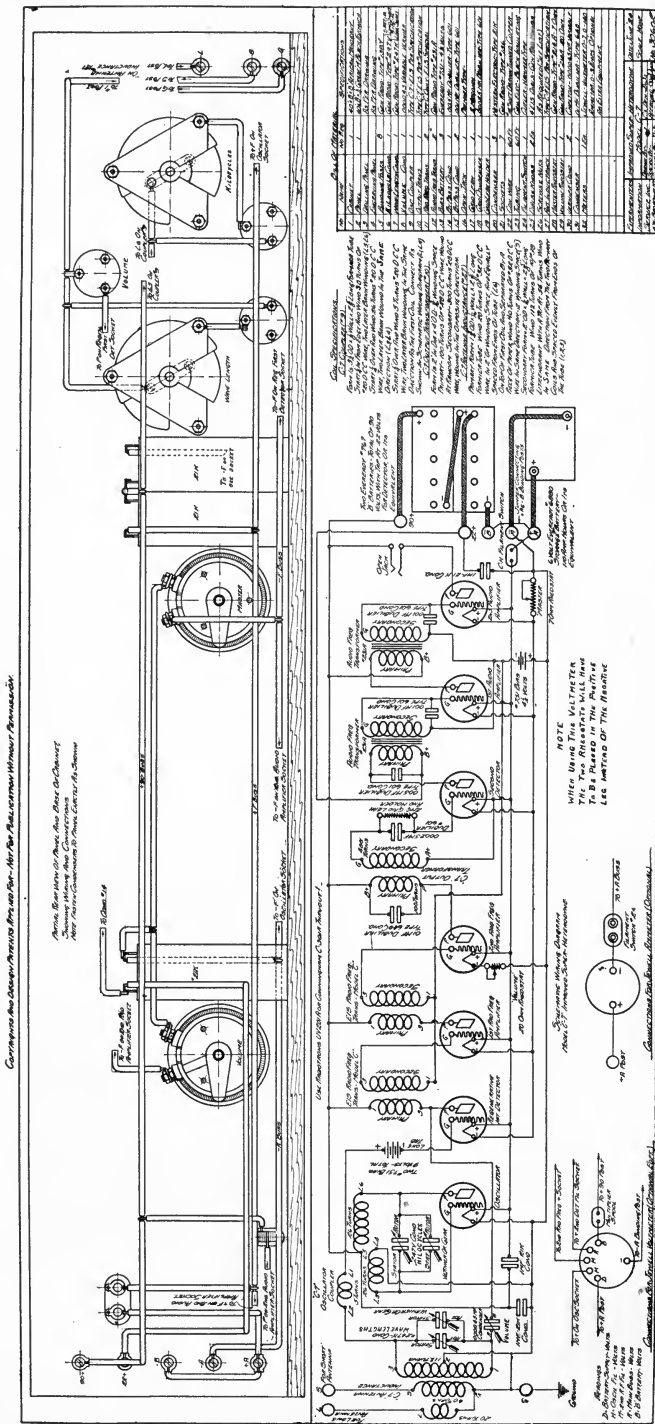

Fig. 168

Schematic Diagram Standard Plio-6.



GREBE CONE SPEAKER

Cone types of Loud Speakers were considered grotesque figures when they first made their appearance on the radio market. Their odd shape earned them the nickname of "Chinese Hats." To this day they are frequently referred to by that name.

As we glance toward the cone speaker, which is by all means the most popular type of loud speaker at the present time, little do we actually realize the months, sometimes years of experimentation required to bring about the perfection of the driving unit employed in these speakers.

The driving unit which is known technically as the motor of the speaker is its heart. It is here that all mechanical and electrical action takes place. The paper cone itself plays a highly important but minor role in reproduction, acting as the diaphragm for the unit, almost the same as the metal disk in the ordinary type of loud speaker. However, this statement must be explained in that the paper cone does not act



Grebe Cone Speaker

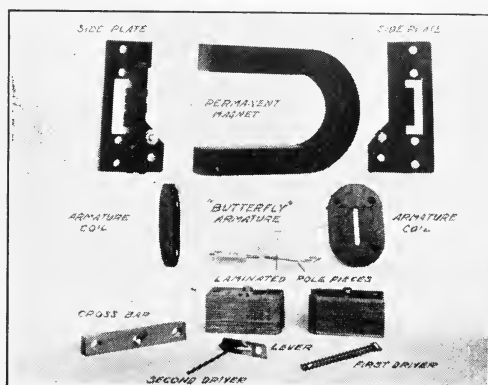

Speaker Parts

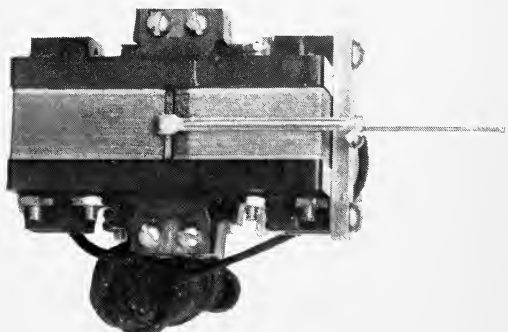

Driving or Motor Unit

magnetically. It is not moved to and fro by the action of the magnets directly; it is however, actuated by means of a driving rod which is connected to the armature which in turn is actually controlled by the magnets. When we say that the cone acts similarly to the ordinary type of speaker, we refer to its action. The paper is actuated by the driving rod and reproduces, through the same process, the vibrations sent to it just as the ordinary diaphragm reproduces the same frequencies through the action of the controlling magnets.

Just how one of the latest cone speakers is made and how it operates can be more readily understood if we select a modern type and explain its action as we are going along.

Let us take the latest cone speaker, the Grebe Type 20-20 unit.

The 20-20 type cone embodies several new and important features in loud speaker design. The type name gives us two right off in that it is twenty inches in diameter and is constructed at an angle of twenty degrees.

On the basis of the latest information available, that experience and research has given us, improvements have been made in both the motor and radiating device.

The design of the latter is simple and can be described in principle as consisting of two cones joined together at their peripheries, one of these cones being frustrated to facilitate mounting. In the choice of the material used in our cones and in their actual size and shape, months of experimentation in conjunction with theoretical calculations on the functioning of radiating members was our only guide. Thus we have selected a material that is stiff enough to carry the energy imparted to it by the driving pin of the motor to the outermost parts of the cone, yet, one which has sufficient internal resistance to wave motion to prevent independent resonances which are heard in many speakers and are known as paper rattles.

A diameter of twenty inches for the cone was selected when experiments had definitely proven that a radiating surface of less area is not capable of reproducing the lower frequencies necessary to good quality reproduction. Any further increase in the diameter of the radiating surface does not result in a perceptible gain in low frequency reproduction, because the effect takes place at frequencies below the lowest heard in the average broadcast reception.

A third feature, in the design of the 20-20 cones is the determination of the optimum angle at the apex of the cone. The final determination of this angle is one of the contributing factors to the high efficiency of this speaker and is based on knowledge of the danger

of undesired resonances that occur with certain angles. In all parts, the mass has been reduced to a minimum, as for example, at the apex of the cone, with the result that the high frequency reproduction is unusually good. Finally the material used to close the opening at the back of the cone provides a slight damping effect to the passage of air in and out of the opening and thus, the unevenness of reproduction in the low frequency range that is noticeable in many speakers is almost entirely absent in this speaker. While a damping effect has been provided, care has been taken to avoid making this effect so marked as to contribute to a reduction in volume of the lower frequencies.

In the design of the motor still more important features are to be found. A discussion of several of these departures from ordinary motor design would be somewhat technical, but the results of these changes can be clearly stated. Among the most important of these may be summed up in five statements which are:

1. A reduction in magnetic saturation with a corresponding decrease in the generation of even harmonics.
2. An unusually high permanent magnetic flux with a corresponding increase in efficiency and a reduction to a minimum of second harmonics introduced in the motor itself.
3. The use of laminated silicon steel in the pole pieces to reduce to a minimum high frequency eddy current losses, the result being an improvement in high frequency reproduction.
4. Moving parts that do not introduce losses by vibrating literally.
5. Large size wire in the coil.

The relative freedom from harmonics, which is one of the features of this speaker, is a big factor contributing to its unusual faithfulness or reproduction. From the point of view of quality, its importance is second only to that of improved reproduction of the very lowest tones which is also a feature of this speaker. The reproduction is, therefore, cleaner, for an electrical impulse of one frequency does not give rise to acoustic vibrations of other frequencies. Comparable in importance with this freedom from harmonics is the relative absence of transients in the paper of the cone and the absence of sustained mechanical vibrations that continue after the electrical impulse has been given.

A photograph reproduced herewith shows the side view of the unit employed in the Grebe speaker, which is the latest in acoustical products.

Another photograph reproduces the likenesses of the various component parts used in the assemblage of a single motor unit.

GREBE SOCKET POWER

A socket power unit, like other radio instruments is no better than its weakest part.

This statement offers a very probable solution to the problem of defective socket power devices. Taking socket power units generally let us summarize the reasons for their failure.

That faulty condenser design and construction has been the outstanding difficulty is an accepted fact.

Further, inferior types of resistance elements and voltage adjusting devices have contributed largely to the dissatisfaction in the operation of various eliminators.

An inadequacy of power and the lack of a corrective device has been the source of complaint in at least fifty per cent. of the eliminator difficulties encountered in connection with average receivers.

The absence of rugged construction and assembly has been conspicuous in most eliminators.

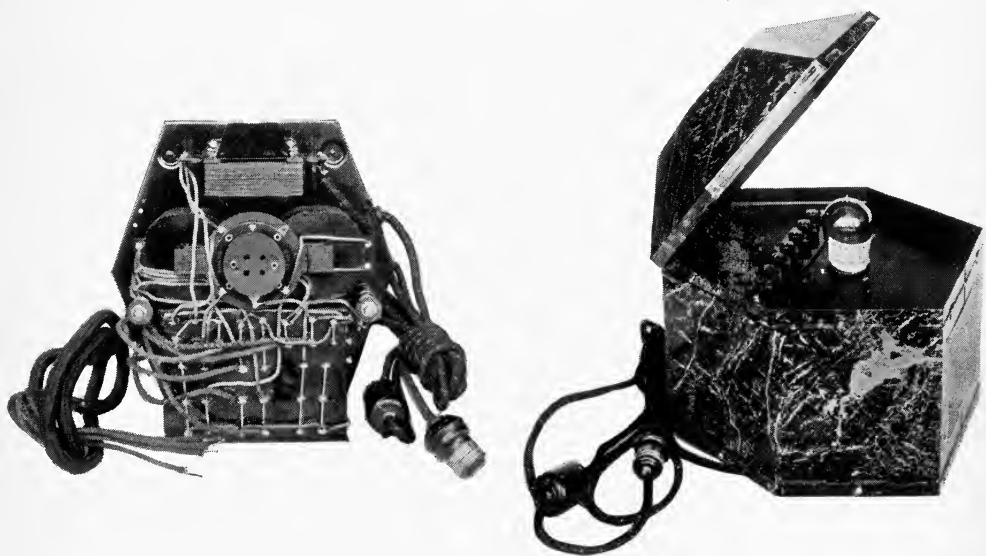

GREBE SOCKET POWER

In the above we have come to the conclusion that undoubtedly the reason for so many failures of condensers in eliminators is that the designers have under-estimated the stresses that such condensers are subjected to in service, and that the designers were rather working up in voltage capacity from what they previously considered a safe

condenser for radio sets operating on "B" batteries of not over 135 volts rather than to view the situation as being more akin to the transmitter rectifier problem.

The main condensers in the Grebe Type 671 socket power are designed to have a large margin of safety factor, and are given individual tests on 1000 volts direct current. Three sheets of the strongest condenser tissue separate the foil plates of the condensers. They are vacuum impregnated in the most approved manner and made moisture proof by an additional dipping process.

Just where these high voltage condensers are employed can readily be seen by glancing at the accompanying schematic circuit diagram where they are indicated by the letter "L."

Secondly, we state that inferior types of resistance elements and voltage adjusting devices have contributed largely to the dissatisfaction in the operation of various eliminators.

Therefore, if we employ full metallic wirewound resistances, wound accurately to resistance as contrasted to the inferior practice of winding so many feet of wire to produce so many ohms resistance, we will satisfactorily eliminate our second problem.

Furthermore, through the use of full metallic wire wound resistors for dividing our voltage we succeed in eliminating erratic voltage variations and noises of various kinds.

The resistances of which we make mention are those indicated at the extreme right hand side of the accompanying schematic circuit diagram.

In the accompanying circuit diagram of the 671 power unit it will be noticed that an unusual circuit appears at the 180 volt positive tap. By the use of the 600 ohm resistance together with the 2 microfarad by-pass condenser which is shunted from the high voltage plus to the negative forty volt "C" terminal, the annoying "motor-boating," or sputtering, noise was entirely eliminated. This latter condition is well-known and so prevalent that almost any radio fan can tell you what it is and no doubt tell you further that he, at some time, has experienced it with an inferior type of socket power device..

The filter circuit of the 671 Socket Power consists of two thirty henry choke coils connected in series with shunting condensers in the positions indicated in the accompanying schematic illustration. These are the high voltage capacities which are given the 1000 volt direct current test.

Designed to operate on alternating current lines of 110 volts at sixty cycles, the step up transformer will operate the eliminator suc-

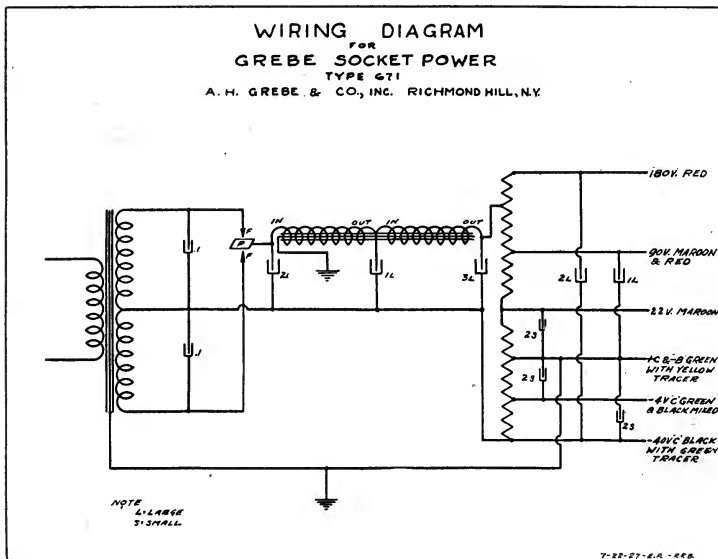

cessfully even if the voltage should drop to 105 volts or soar to 135 volts. On each side of the mid-tap of the secondary winding a voltage of 350 is available. This is fed through the type BH Raytheon full wave rectifying tube, thence through the filter circuit to the voltage dividing resistances, where from 180 volts plus for the power amplifier the voltage is divided into the following potentials: 90 plus for intermediate radio and audio frequency stages; 22 plus for detector; common C plus and B minus; and 40 and 4 negative C voltages.

For the benefit of home constructors we have indicated on the accompanying diagram the capacities of the various condensers.

The resistance used to divide the voltages are as follows, and between the points mentioned:

Between the 180 volt plus tap and the out put lead of the filter circuit, 600 ohms.

Between this lead and the 90 volt plus tap 3600 ohms.

Between the ninety volt tap and the 22 volt tap, 8700 ohms.

From the twenty-two volts tap to the "C" plus, "B" minus a resistance of 4100 ohms.

Between the "C" plus "B" minus and negative "C" four volt tap, 85 ohms.

From negative four volts to negative forty volts, 950 ohms.

Each of the two filter chokes has 9500 turns layer wound. Each layer being sufficiently insulated from the preceding one. These as we mentioned before are of thirty henries apiece.

The construction and circuit of this unit is such that any variation in the line voltage will not effect the balance of the output voltages. (i. e., any rise in B voltage, due to line voltage variation, will result in an equally proportioned rise in the C potential.

The completed Grebe Socket power type 671 is enclosed in an hexagonally shaped container having an attractive marble finish. A small well is provided for the socket, otherwise the interior is completely shielded and protected from accidental contact when inserting the Raytheon tube.



Testing "B" Eliminators in the General Radio Laboratories.

ACOUSTIC CHART

WIND INSTRUMENTS

Piccolo

Flute

Oboe

Clarinet

Trumpet

French Horn

Trombone

Bass Clarinet

Bassoon

Bass Tuba

PERCUSSION INSTRUMENTS

Kettle Drums

STRING INSTRUMENTS

Violin

Viola

Cello

Bass Viol

HUMAN VOICE

Soprano

Alto

Tenor

Baritone

Bass

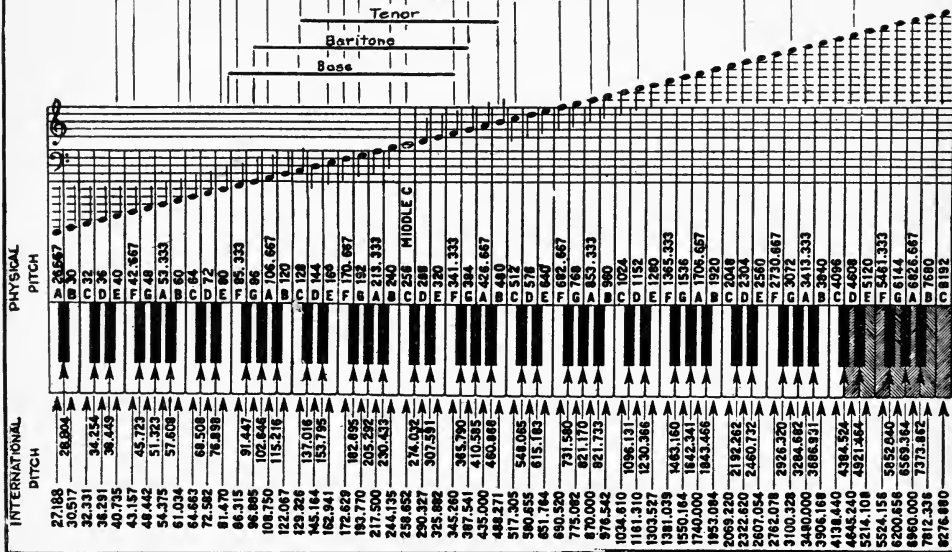

CORRELATED ACOUSTIC CHART

This chart represents the relation between the musical scale and piano keyboard, giving the frequencies of each note in terms of complete vibrations per second according to the two principal scales and pitches used in musical and scientific work, viz: The INTERNATIONAL equally tempered scale based on A=435 complete vibrations per second, which is generally used by musicians—the SCIENTIFIC or PHOLOSOPHICAL scale—generally used by physicists—based on MIDDLE C=256 complete vibrations per second. It also shows the correlated range of the various instruments within the orchestral range and the different voices which constitute the vocal range. The shaded keys are not included on a standard piano keyboard. The extreme organ range not shown on the chart is from 16 cycles to 16,384 cycles, PHYSICAL pitch.

A DISCUSSION OF CONDENSER PLATE SHAPES

Variable air condensers are made with three general types of plate shapes, although there are many modifications of each type.

The first rotary variable condensers were made with "straight line capacity" plates. These plates were semi-circular in shape and are called straight line capacity because the curve of capacity plotted against dial divisions (angle of rotation) is a straight line. The relation between capacity, wavelength, and frequency are such that this plate shape tends to result in crowding of stations at the lower end of the capacity range. That is, there are more transmitting channels for each dial division at the lower end of the scale than the upper. This objectionable feature has led to a widespread of other plate shapes.

The straight line capacity plates have, however, one distinct advantage when used in single-control set-ups. Where it is desired to tune several circuits with one control, some form of capacity adjustment is nearly always necessary to compensate for different zero capacitances in the several circuits. If semi-circular, (straight line capacity) units are used, this adjustment can be made by slightly advancing one or more of the units. If this be done with condensers having other plate shapes, the capacities will become unbalanced as the control dial is advanced. This is due to the fact that if the plate shape is not "straight line capacity," the capacity variation per dial division increases as the condenser is turned toward maximum capacity, and the unit which was advanced gains capacity more rapidly than the others. This feature has caused at least one important manufacturer of uni-control receivers to return to the semi-circular plate shape.

It may be noted that the effect of "straight line wavelength" and "straight line frequency" condensers is strictly a slow motion action, having a variable reduction, gradually lessening as the condenser is advanced. The same result can be and, in fact, has been accomplished by a slow motion dial so constructed as to automatically vary its reduction ratio to give the effect of a "straight line frequency" plate when used with a "straight line capacity" condenser.

The disadvantage of the semi-circular plate shape was first realized in connection with the construction of wavemeters. This was long before there were enough broadcast stations for the problem of station separation to be serious. As the relation between capacity and wavelength is not a direct proportion, a dial calibrated in wavelengths will

not have equal divisions over its scale if a semi-circular plate shape is used. This not only makes the instrument more difficult to read, particularly as to the estimation of readings which fall between divisions, but involves difficulty in calibration, as the space between two points ten meters apart for instance, could not be divided into ten equal one-meter divisions. A plate shape which would give equal divisions for equal wave-length, i.e., "straight line wavelengths," was highly desirable, and a condenser with such a plate shape was first used commercially in the General Radio 124 wavemeter, introduced in 1916. When the multiplication of broadcast stations began, the straight line wavelength plate was introduced for condensers used in receivers, and became very popular, due to the better separation of stations resulting from its use.

Broadcast stations continued to multiply, however, until all channels in the wavelength range allotted to broadcasting were filled. The transmission channels were assigned on the basis of uniform frequency rather than uniform wavelength separation, and, as they all became occupied, the difficulty of crowding a great many more than half the stations into the lower half of the dial again rose. The obvious step was, of course, the "straight line frequency plate" shaped to give equal frequency divisions over the dial. This plate shape not only improves the distribution of stations over the dial, but is the only type of condenser which can be used in a single-control superheterodyne, where there is a constant difference of frequency between the two circuits being tuned.

Certain objections, however, have prevented this type of condenser from achieving the wide popularity which was promised for it. In order to obtain a "straight line frequency" variation, an extremely low minimum capacity is required. The stray or "zero" capacity of most receivers is so large as to defeat this requirement and to prevent the realization of a true straight line frequency variation. Another objection was the large physical dimensions of most of the straight line frequency condensers, due to the fact that this plate shape is very inefficient in its use of space. Then, too, there is the fact that in the conventional type of condenser, there is a rotation of but 180° in which all stations must be included. Spreading out stations on the lower portion of the dial necessarily results in crowding them closer together on the upper. It so happened that the policy of the government in assigning channels was to give the high powered stations channels in the upper portion of the wave band, and the crowding together of these stations, generally having the better programs, proved disadvantageous.

SHORT WAVE RECEPTION

In order to appreciate the work that is being done today with low power, it is necessary to briefly review the history of short wave communication—pioneered by the American Amateur.

In 1912 the Department of Commerce classified and licensed all radio stations, assigning certain wavelengths to each class of station. In order to prevent amateur interference with Naval and commercial traffic, the wavelength of 200 meters (then considered useless) was assigned them, with provision for a few special stations on 275 and 375 meters.

Although limited to low power on 200 meters, it took but a few years for the amateur to perfect apparatus which enabled him to communicate up to two thousand miles. While not consistent these results were encouraging and the amateur saw possibilities not then realized by commercial companies.

Except for the period during the World War, when amateur activities were suspended, continuous progress was made. With the development of tube transmitters for continuous waves (C. W.) and telephone transmission, new interest was aroused, the number of amateurs increased and practical broadcasting was accomplished.

Following these developments commercial companies became interested in broadcasting and it was not long before the number of broadcasting stations became so numerous that new wave bands were necessary. To make room for additional broadcasting stations and to remove the possibility of interference from amateur transmitters a radio conference was called by Secretary Hoover in Washington, D. C. As a result of this conference, the amateurs were assigned a wave band extending from 150 to 200 meters.

After operating on the lower portion of this band for a short period, it was found that greater distances could be covered than was heretofore possible. This led many to believe that the wavelengths below 150 meters held further possibilities.

A few amateurs therefore obtained a special license which permitted them to operate on wavelengths as low as 100 meters and for the first time they succeeded in carrying on communication with France and many other foreign countries. This remarkable work encouraged many experimenters to drop to still lower wavelengths. Tests and experiments on wavelengths as low as 10 meters indicated that extremely short waves offered a fertile field for research and was useful for long distance communication with low power.

For the first time, the United States Army and Navy and commercial companies began to realize the importance of the low wave-

lengths and erected many stations in order to further study the characteristics of these high frequencies. Many foreign countries also began to utilize the shorter wavelengths and the number of these short wave stations increased rapidly.

At the present time the Department of Commerce has allocated wavelengths down to .74 meters, as shown on page 224 and commercial companies are effecting trans-continental, trans-oceanic and relay broadcasting on their respective assignments. Using the present assignments, world-wide communication by amateurs, both day and night, is a common occurrence. Not only has such communication been established using C. W. but amateurs have also succeeded in transmitting the human voice a distance of twelve thousand miles.

The greatest of amateur achievements took place on April 17, 1925, when delegates of twenty-three nations assembled in conference in Paris and formed the International Amateur Radio Union, I.A.R.U., electing H. P. Maxim, U. S. A., president and K. B. Warner, U. S. A., Secretary and Treasurer. The purposes of this union is to encourage international two-way communication on amateur wavelengths.

You have read what the amateurs have already accomplished—what they will do in the future we dare not predict.

THEORY OF SHORT WAVES

It would be beyond the scope of this book to discuss in detail the various theories of short wave propagation, however, we believe it is important to mention the fact that the very short waves do not follow the curvature of the earth as do the longer waves but are reflected by some medium in the upper atmosphere. This reflection results in what is now termed a "skipped distance effect;" in other words, a signal which is very strong a thousand miles away might be inaudible a few hundred miles from the transmitter. The "skipped distance effect" is determined by the season of the year, the time of day, wavelength used, and the power and location of the transmitter.

Further knowledge of short wave characteristics can be obtained only by careful and diligent experimentation. A great deal of this experimental work can be accomplished by any one who will listen in on the short wave lengths and keep an accurate record of the results obtained. Such records maintained over a period of several months would prove invaluable to the advancement of this science.

SHORT WAVE RECEIVER DESIGN

In designing a receiver for short wave reception many problems are encountered which are not met with when dealing with the higher wavelengths.

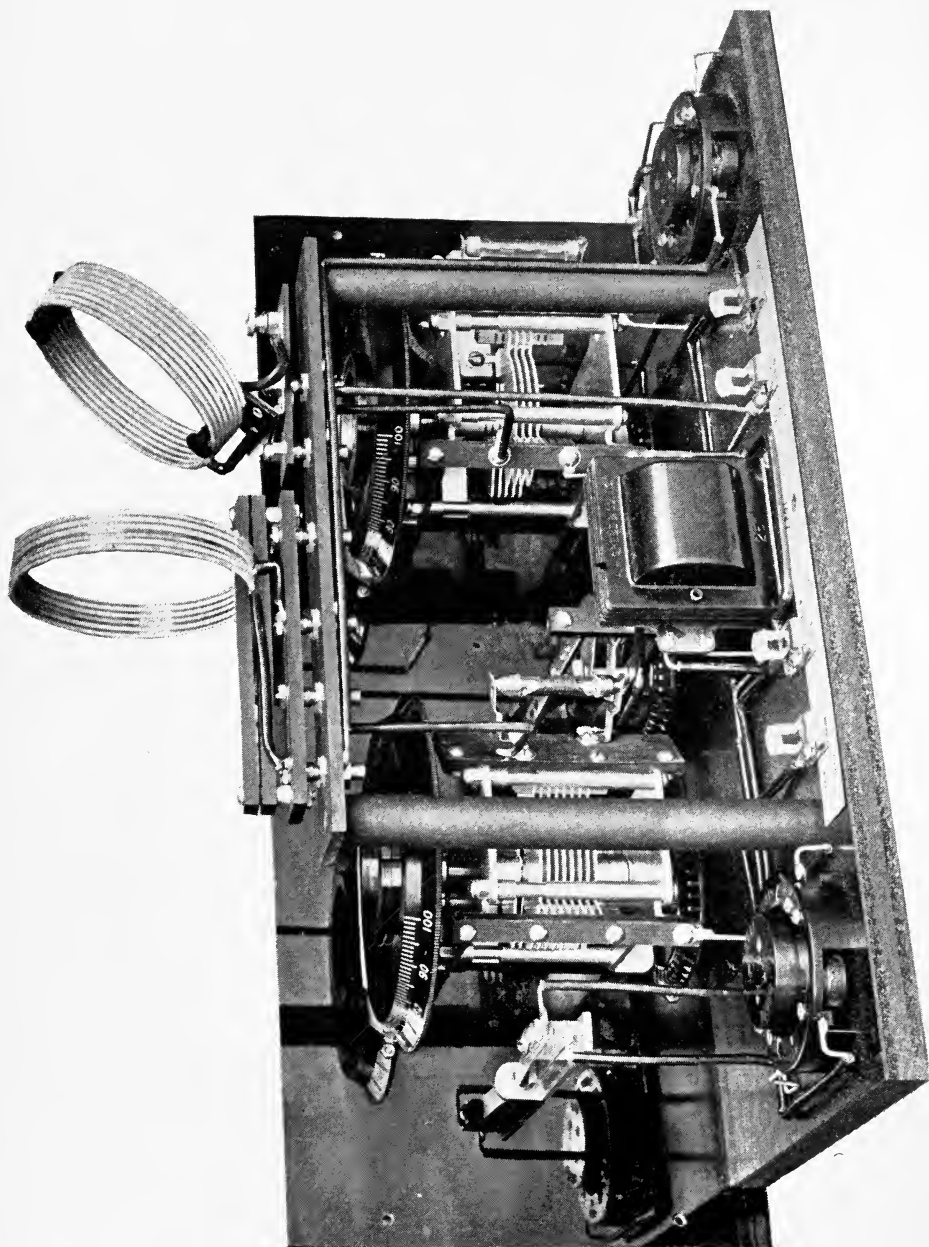

Grebe C-R-18 Short Wave Receiver

The adjustable tickler coil circuit, for example, is inferior at very short wavelengths because a change in regeneration produces so great a change in wavelength that the transmitting station cannot be received with any degree of certainty. On the other hand, the capacity feedback coupling method generally used is such that the stray capacity effect is so great that tuning is destroyed and the receiver becomes difficult to operate. While a few receivers have been designed, using the above mentioned circuits, generally the wavelength range of such sets is small and they can only be used to cover a limited band.

In order to receive continuous wave stations to the best advantage the circuit should be such that the point of oscillation is practically constant over the entire tuning range. For reception of broadcasting on the high frequencies however, the regeneration control should operate in such a manner that the change from oscillating to non-oscillating condition is gradual rather than sudden.

The CR-18 receiver has been designed with all these points in mind, and a study of the circuit will reveal the following features:—variable electro-magnetic coupling between the antenna and secondary circuit is employed contrary to the usual practice of using a small coupling condenser. This coupling coil permits a greater transfer of energy without affecting the wavelength calibration, and affords greater selectivity, reduces interference and induction noise and makes possible the use of harmonic tuning when using a large antenna.

In order that tuning will not be too critical the receiver is provided with five different coils which cover wavelength ranges, as shown on the chart and the various calibration curves. These coils are fitted with plugs and are mounted outside of the cabinet, in order to reduce all losses and permit the coils to be interchanged without delay or difficulty.

Although each coil covers only a small wavelength range the frequency range is very large and for this reason the beat frequency control, consisting of a small variable air condenser, is incorporated in the receiver. This condenser permits one to discriminate between stations separated by only a fraction of a kilocycle and makes it possible to hold a station which is swinging or changing its frequency.

In place of a choke-coil in the plate circuit, the CR-18 employs a resistance. This resistance eliminates non-oscillating points in the tuning range which frequently occur when a choke-coil is used.

Cushion sockets are used to eliminate all vibration and microphonic disturbances, which seriously affect the operation of a short wave receiver.

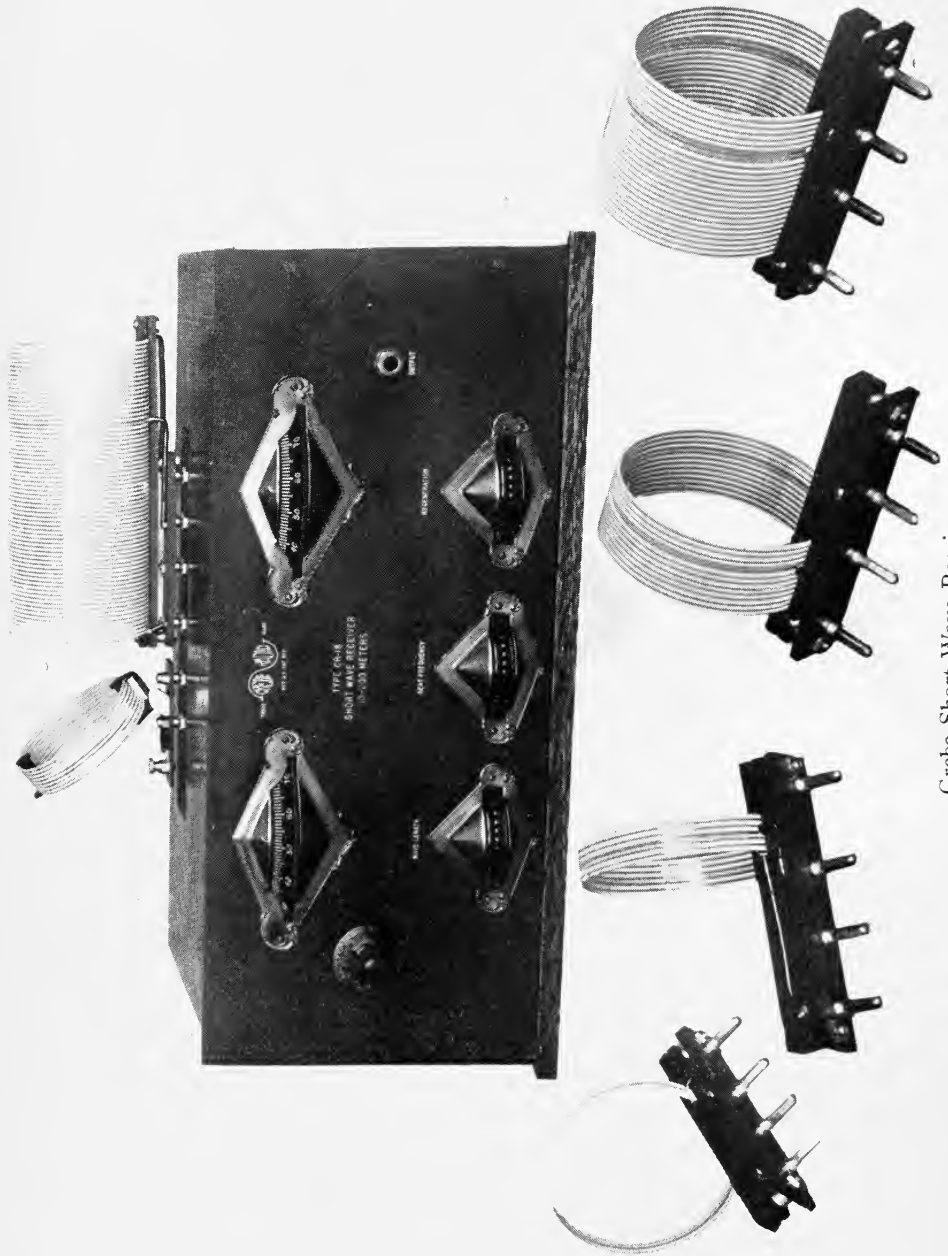

Grebe Short Wave Receiver.

OPERATING INSTRUCTIONS

The CR-18 was designed to operate with 201-A, 5 volt, .25 ampere, X type base vacuum tubes. It is some times advisable to reverse the tubes in order to obtain the most desirable results. A storage battery should be used for filament supply.

At least 90 volts of B battery is necessary. A clip should be provided on the detector lead so that vibration of detector plate voltage may be easily secured, as certain coils require more voltage than others, as shown on the calibration curves.

A grid leak of proper value is furnished with the receiver. If there is an occasion to replace this, a leak of at least 7 megohms resistance should be used. A lower value than this will cause unstable operation and generally produces howling and squealing.

Mounted on the side of the regeneration condenser are two clips which hold the regeneration stabilizer unit. This is a 25,000 ohm grid leak type resistance.

The antenna should consist of a single wire approximately 75 or 100 feet in length including the lead-in and should be well insulated. Good results may be obtained with an antenna as short as 25 feet, or even an indoor antenna may be resorted to. Connection to the ground should be made securely by means of a ground clamp fastened to a water pipe or radiator system. Care should be exercised in making all connections, as loose connections are more detrimental on short waves than on the higher wavelengths.

After connections have been properly made, insert coil No. 3 (the 40 meter coil) in the jack mounting. Do not insert the antenna coil or connect the antenna, but turn the rheostat to 2 and plug the telephone receivers in the jack provided for this purpose.

Set the wavelength dial on 'O' and starting at 'O' on the regeneration dial slowly increase the reading to 35 or as far as necessary to cause indications of oscillation to be heard in the telephones. This point, as noted from the calibration curves, is usually 40 but will be subject to slight variations. When the point on the regeneration dial at which oscillations occur has been determined, move the dial 5 points higher. The receiver should now be in an oscillating condition over the entire wavelength range covered by the wavelength dial. A simple test to determine whether the receiver is oscillating or not is to touch the left hand screw on the secondary coil and if a click is heard in the telephones the receiver is oscillating.

Insert the antenna coupling coil and connect the antenna to the binding post provided. Adjust the antenna coil so that there is a separation of 2 inches between the top of this coil and the top of the secondary.

Note again whether oscillations take place; if they have stopped, increase the regeneration dial 10 degrees and if this is not sufficient to cause oscillations, further separate the antenna coil from the secondary coil. Starting at 'O' move the wavelength dial to 100 and if points are found where the receiver stops oscillating it indicates that the antenna circuit or a harmonic of it is in tune with the secondary circuit. If in later experience it is found that these non-oscillating points fall directly in the most generally used wavelength ranges, the points may be shifted by either lengthening or shortening the aerial. It will be impossible under certain conditions to eliminate all these points, regardless of the treatment of the antenna, but when these points occur moving the antenna coil further away from the secondary coil will again permit oscillation to be maintained. Moving the regeneration dial to a higher point will also accomplish this, but it is preferable to utilize the antenna coupling coil for this purpose.

With further reference to the occurrence of non-oscillating points on the wavelength dial, some may prefer to use a third method of shifting or eliminating such points. It may be accomplished by connecting a small variable condenser with a capacity of .0003 or .0005 between the aerial and the antenna binding post on the receiver. By tuning the external condenser a point will be found where the receiver stops oscillating and by adjusting the condenser, above or below this point, stable operation will again be restored.

It is important for the operator to fully appreciate the advantages that may be gained by harmonic tuning. This can be accomplished by using a small variable condenser connected in series with the antenna and the coupling coil. The effects are most noted on wavelengths in which the fundamental period of the antenna is some multiple of the received wavelength.

For example, if the length of the antenna is such that when it is connected to the antenna coupling coil it has a natural period of 300 meters the following harmonics would occur; second harmonic at 150 meters; third at 100 meters; fourth at 75 meters; fifth at 60 meters, etc. If the antenna coil is close to the secondary coil the receiver will stop oscillating at these wavelengths, however, if oscillations are again restored by any of the previously mentioned methods, stronger signals will be obtained at these points than on other wavelengths in the tuning range. It is therefore possible to adjust any antenna so that some harmonic falls on approximately the wavelengths one desires to receive. The advantage of this method is that a long antenna may be used, which naturally will have better pick-up qualities.

Hawaii	San Francisco P. C. T.	Denver M. S. T.	Chicago C. S. T.-D	Havana Cuba	New York- Washington E. S. T.	Daylight Saving	Halifax Buenos Aires	Rio de Janeiro Brazil	London Paris Madrid	G
1.30P.M.	4.00P.M.	5.00P.M.	6.00P.M.	6.30P.M.	7.00P.M.	8.00P.M.	8.00P.M.	9.00P.M.	Midnight	00
2.30	5.00	6.00	7.00	7.30	8.00	9.00	9.00	10.00	1.00A.M.	01
3.30	6.00	7.00	8.00	8.30	9.00	10.00	10.00	11.00	2.00	02
4.30	7.00	8.00	9.00	9.30	10.00	11.00	11.00	Midnight	3.00	03
5.30	8.00	9.00	10.00	10.30	11.00	12.00	Midnight	1.00A.M.	4.00	04
6.30	9.00	10.00	11.00	11.30	Midnight	1.00A.M.	1.00A.M.	2.00	5.00	05
7.30	10.00	11.00	Midnight	12.30A.M.	1.00A.M.	2.00	2.00	3.00	6.00	06
8.30	11.00	Midnight	1.00A.M.	1.30	2.00	3.00	3.00	4.00	7.00	07
9.30	Midnight	1.00A.M.	2.00	2.30	3.00	4.00	4.00	5.00	8.00	08
10.30	1.00A.M.	2.00	3.00	3.30	4.00	5.00	5.00	6.00	9.00	09
11.30	2.00	3.00	4.00	4.30	5.00	6.00	6.00	7.00	10.00	10
12.30A.M.	3.00	4.00	5.00	5.30	6.00	7.00	7.00	8.00	11.00	11
1.30	4.00	5.00	6.00	6.30	7.00	8.00	8.00	9.00	Noon	12
2.30	5.00	6.00	7.00	7.30	8.00	9.00	9.00	10.00	1.00P.M.	13
3.30	6.00	7.00	8.00	8.30	9.00	10.00	10.00	11.00	2.00	14
4.30	7.00	8.00	9.00	9.30	10.00	11.00	11.00	Noon	3.00	15
5.30	8.00	9.00	10.00	10.30	11.00	12.00	Noon	1.00P.M.	4.00	16
5.30	9.00	10.00	11.00	11.30	Noon	1.00P.M.	1.00P.M.	2.00	5.00	17
7.30	10.00	11.00	Noon	12.30P.M.	1.00P.M.	2.00	2.00	3.00	6.00	18
8.30	11.00	Noon	1.00P.M.	1.30	2.00	3.00	3.00	4.00	7.00	19
9.30	Noon	1.00P.M.	2.00	2.30	3.00	4.00	4.00	5.00	8.00	20
10.30	1.00P.M.	2.00	3.00	3.30	4.00	5.00	5.00	6.00	9.00	21
11.30	2.00	3.00	4.00	4.30	5.00	6.00	6.00	7.00	10.00	22
12.30P.M.	3.00	4.00	5.00	5.30	6.00	7.00	7.00	8.00	11.00	23

Sweden Germany Switzerland Italy	Petrograd Constantinople Capetown Jerusalem	Bagdad Persia	Calcutta Bombay India	Borneo Java Dutch E. I.	Manila P. I. China Western Australia	Tokio Central Australia	Sidney Melbourne Eastern Australia	Auckland New Zealand	Samoa
1.00A.M.	2.00A.M.	3.00A.M.	5.00A.M.	6.00A.M.	8.00A.M.	9.00A.M.	10.00A.M.	11.30A.M.	Noon
2.00	3.00	4.00	6.00	7.00	9.00	10.00	11.00	12.30P.M.	1.00P.M.
3.00	4.00	5.00	7.00	8.00	10.00	11.00	Noon	1.30	2.00
4.00	5.00	6.00	8.00	9.00	11.00	Noon	1.00P.M.	2.30	3.00
5.00	6.00	7.00	9.00	10.00	Noon	1.00P.M.	2.00	3.30	4.00
6.00	7.00	8.00	10.00	11.00	1.00P.M.	2.00	3.00	4.30	5.00
7.00	8.00	9.00	11.00	Noon	2.00	3.00	4.00	5.30	6.00
8.00	9.00	10.00	Noon	1.00P.M.	3.00	4.00	5.00	6.30	7.00
9.00	10.00	11.00	1.00P.M.	2.00	4.00	5.00	6.00	7.30	8.00
10.00	11.00	Noon	2.00	3.00	5.00	6.00	7.00	8.30	9.00
11.00	Noon	1.00P.M.	3.00	4.00	6.00	7.00	8.00	9.30	10.00
Noon	1.00P.M.	2.00	4.00	5.00	7.00	8.00	9.00	10.30	11.00
1.00P.M.	2.00	3.00	5.00	6.00	8.00	9.00	10.00	11.30	Midnight
2.00	3.00	4.00	6.00	7.00	9.00	10.00	11.00	12.30A.M.	1.00A.M.
3.00	4.00	5.00	7.00	8.00	10.00	11.00	Midnight	1.30	2.00
4.00	5.00	6.00	8.00	9.00	11.00	Midnight	1.00A.M.	2.30	3.00
5.00	6.00	7.00	9.00	10.00	Midnight	1.00A.M.	2.00	3.30	4.00
6.00	7.00	8.00	10.00	11.00	1.00A.M.	2.00	3.00	4.30	5.00
7.00	8.00	9.00	11.00	Midnight	2.00	3.00	4.00	5.30	6.00
8.00	9.00	10.00	Midnight	1.00A.M.	3.00	4.00	5.00	6.30	7.00
9.00	10.00	11.00	1.00A.M.	2.00	4.00	5.00	6.00	7.30	8.00
10.00	11.00	Midnight	2.00	3.00	5.00	6.00	7.00	8.30	9.00
11.00	Midnight	1.00A.M.	3.00	4.00	6.00	7.00	8.00	9.30	10.00
Midnight	1.00A.M.	2.00	4.00	5.00	7.00	8.00	9.00	10.30	11.00

It is important for the operator to realize at the outset that the frequency bands included in a single wavelength dial division is sufficient to accommodate as many as 15 stations and while very fine tuning can be secured with the tangent wheel, many of the stations will be passed over unless use is made of the beat frequency control. The tuning values of the main wavelength condenser and the beat frequency control are so proportioned that whereas approximately 15 stations will be found in one degree of the wavelength dial (one notch of the tangent wheel) each station may be separated by approximately one notch on the beat frequency control wheel. With this in mind the operator will soon become familiar with the tuning capabilities of this receiver.

While the foregoing instructions are satisfactory for preliminary operation the following should help one to obtain still more satisfactory results.

When receiving C. W. or I. C. W. code signals the regeneration dial should be reduced to the lowest reading possible where oscillations are just maintained. This will result in weak signals being received with greater intensity. In other words, the weaker the signals the weaker the oscillations in the receiver should be for maximum intensity in the telephones. However, where signals are easily readable stronger oscillations may be used and are helpful in reducing noises and low frequency interference.

In order to receive broadcasting or speech it is necessary to keep the receiver in a non-oscillating condition. Maximum strength of reception will be obtained when the regeneration dial is set just below the oscillating point. A final critical adjustment can be made by using the filament rheostat.

LIST OF INTERNATIONAL INTERMEDIATES

(Standardized by I.A.R.U.)

The letters listed below precede the regular call signals and are used to designate the country where the transmitting station is located.

Example:—4AA-4AA-4AA-ZU-2ZV-2ZV-2ZV. The intermediates ZU mean that a station with the call signals 4AA located in New Zealand is being called by a station with call signals 2ZV located in the United States.

AU —Alaska	K —Germany (unauthorized)
B —Belgium	L —Luxembourg
BE —Bermuda	M —Mexico
BZ —Brazil	N —Netherlands
C —Canada and New England	O —South Africa
CH —Chile	PI —Philippine Islands

- | | |
|------------------------------|--|
| CR—Costa Rica | P —Portugal |
| D —Denmark | PR—Porto Rico |
| E —Spain | Q —Cuba |
| F —France | R —Argentine |
| FI—Indo-China (unauthorized) | S —Scandinavia (Denmark, Finland, Iceland, Norway, Sweden) |
| G —Great Britain | U —United States |
| H —Switzerland (Helvetia) | Y —Uruguay |
| HU—Hawaii | Z —New Zealand |
| I —Italy | |
| J —Japan (provisional) | |

SIGNALS DESIGNATING RELATIVE—

AUDIBILITY

- R-1 Faint signals, just audible.
- R-2 Weak signals, barely audible.
- R-3 Weak signals, but readable.
- R-4 Fair signals, easily readable.
- R-5 Moderately strong signals.
- R-6 Strong signals.
- R-7 Good strong signals, readable through heavy QRN and QRM.
- R-8 Very strong signals, several feet from the phones.
- R-9 Extremely strong signals.

The old QSA—QRZ—QRK arrangement was so unsatisfactory that the “R” system of indicating “Audibility” has been universally adopted.

READIBILITY

1	10%	Readable.
2	20%	“
3	30%	“
4	40%	“
5	50%	“
6	60%	“
7	70%	“
8	80%	“
9	90—100%	“

A signal may be **Audible** (R-8 several feet from phones) but if there is any great amount of QRM or QRN or if the character of the note is poor, the **Readability** may be very low. A second figure as above added to the **Audibility** table indicates the percentage copy or percentage **Readability**.

EXAMPLE

(1) If signals are reported “R 99” it would mean—extremely strong signals with 100% copy.

(2) On the other hand, your signal may be reported “R-91”—it would mean extremely strong signals but due to excessive QRM or QRN—or possibly a poor note only 10% copy could be made.

(3) Again, signals could be reported “R-39” this would mean weak signals but due to perfect note, absence of any QRM or QRN, or other disturbing factor 100% copy was being made.

WINDING DATA FOR INDUCTANCE COILS

USED WITH
GREBE SHORT WAVE RECEIVER TYPE CR-18
 A. H. GREBE & CO., INC. RICHMOND HILL, N. Y.

COIL No.	WAVELENGTH RANGE METERS	L ₁	SPACE	L ₂	FREQUENCY RANGE MEGA-CYCLES
1	8.5-18	1	1	2	16.6-35
2	15.8-31	3	1	2	9.7-19
3	29-62	8	1	4	4.85-10.3
4	56-112	18	2	6	2.68-5.35
5	107-216	49	1	18	1.38-2.8

NOTE - ALL COILS ARE WOUND (3 INCH DIAMETER) WITH #16 S.C.C. COPPER WIRE
 SPACED 10 TURNS PER INCH

INTERNAL WIRING DIAGRAM
FOR
GREBE SHORT WAVE RECEIVER TYPE CR-18
 A.H. GREBE & CO., INC. RICHMOND HILL, N.Y.

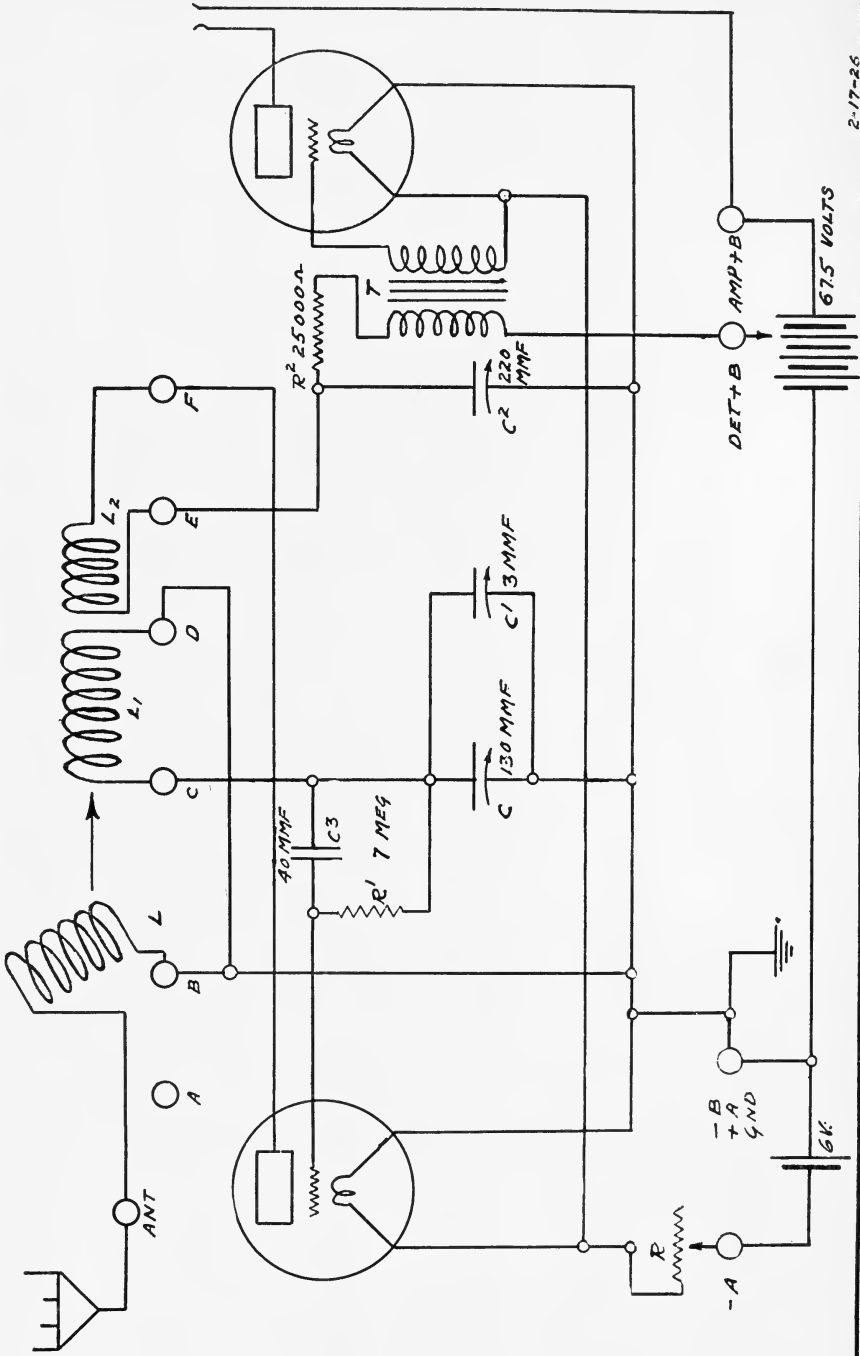

SHORT WAVE STATIONS OF THE WORLD

Call	Location	Frequency	Meters	Coil
POF	Nauen, Germany	22209	13.5	#1
2XS	Rocky Point, New York	20082	14.93	#1
2XAW	Schenectady, New York	19988	15	#1
2BR	Chelmsford, England	19988	15	#1
2XE	A. H. Grebe & Co., Inc., New York	19988	15	#1
POF	Nauen, Germany	18738	16	#2
NKF	Anacostia, District of Columbia	18738	16	#2
2BR	Chelmsford, England	17636	17	#2
POF	Nauen, Germany	16657	18	#2
2XAD	Schenectady, New York	14991	20	#2
KFVM	S. S. Idalia	14991	20	#2
POF	Nauen, Germany	14991	20	#2
NAL	Washington, District of Columbia	14991	20	#2
NEPQ	U. S. S. Relief	14991	20	#2
2ZV	A. H. Grebe & Co., Inc., New York	14991	20	#2
NKF	Anacostia, District of Columbia	14414	20.8	#2
WIK	Rocky Point, New York	13628	22	#2
2YT	Poldhu, England	11993	25	#2
POY	Nauen, Germany	11993	25	#2
FW	Sainte Assise, France	11993	25	#2
NKF	Anacostia, District of Columbia	11758	25	#2
AGA	Nauen, Germany	11532	26	#2
PCMM	Kootwijck, Holland	10903	27.5	#2
POW	Nauen, Germany	10708	28	#2
2XI	Schenectady, New York	9994	30	#2
NAL	Washington, District of Columbia	9798	30.6	#3
2YT	Poldhu, England	9369	32	#3
ANE	Malabar, Java	9369	32	#3
2XE	A. H. Grebe & Co., Inc., New York	9369	32	#3
NAJ	Great Lakes, Illinois	8630	34	#3
WQO	Rocky Point, New York	8560	35.03	#3
PCMM	Kootwijck, Holland	8328	36	#3
PCUU	Kootwijck, Holland	7890	38	#3
KFVM	S. S. Idalia	7496	40	#3
NAS	Pensacola, Florida	7496	40	#3
NAJ	Great Lakes, Illinois	7496	40	#3
NPG	San Francisco, California	7496	40	#3
NRRL	U. S. S. Seattle	7496	40	#3
NQW	U. S. S. New Mexico	7496	40	#3
2XAC	Schenectady, New York	7496	40	#3
2ZV	A. H. Grebe & Co., Inc., New York	7496	40	#3
NKF	Anacostia, District of Columbia	7260	41.3	#3
2XAF	Schenectady, New York	7160	41.88	#3
5XH	New Orleans, Louisiana	7139	42	#3
FW	Sainte Assise, France	7139	42	#3
WIZ	Rocky Point, New York	6970	43.02	#3
WQO	Rocky Point, New York	6841	44	#3
KZA	Los Angeles, California	6841	44	#3
KZB	Los Angeles, California	6841	44	#3
PCLL	Kootwijck, Holland	6518	46	#3
WHD	Sharon, Pennsylvania	6119	49	#3
NPM	Honolulu, Territory of Hawaii	6119	49	#3
2XAD	Schenectady, New York	5996	50	#3
SAJ	Karlsborg, Sweden	5996	50	#3
WON	Rocky Point, New York	5822	51.5	#3
NPU	Tutuila, Samoa	5657	53	#3
NBA	Balboa, Canal Zone	5552	54	#3
NKF	Anacostia, District of Columbia	5811	54.4	#3

WQN.....	Rocky Point, New York.....	5501.....	54. 5.....	43
KFKX.....	Hastings, Nebraska.....	5354.....	56.....	43
ANF.....	Malabar, Java.....	5354.....	56.....	43
IXAO.....	Belfast, Maine.....	5354.....	56.....	43
WQN.....	Rocky Point, New York.....	5260.....	57.....	43
KDKA.....	East Pittsburgh, Pennsylvania.....	5100.....	58. 79.....	44
KDC.....	Casper, Wyoming.....	5082.....	59.....	44
2YT.....	Poldhu, England.....	4997.....	60.....	44
KDKA.....	East Pittsburgh, Pennsylvania.....	4759.....	63.....	44
WRMU.....	A. H. Grebe & Co., Inc., New York, Marine Broadcast Station.....	4579.....	63.....	44
WGMU.....	A. H. Grebe & Co., Inc., New York, Mobile Broadcast Station.....	4759.....	63.....	44
2XE.....	A. H. Grebe & Co., Inc., New York.....	4759.....	63.....	44
8XS.....	East Pittsburgh, Pennsylvania.....	4475.....	67.....	44
NPO.....	Cavite, Philippine Islands.....	4409.....	68.....	44
WRB.....	Miami, Florida.....	4383.....	68. 4.....	44
WRP.....	Miami, Florida.....	4383.....	68. 4.....	44
2XOA.....	Belfast, Maine.....	4283.....	70.....	44
POX.....	Nauen, Germany.....	4283.....	70.....	44
NPO.....	Cavite, Philippine Islands.....	4283.....	70.....	44
NERM.....	U. S. S. Los Angeles.....	{ 4283.....	70 to }.....	44
		} 4283.....	84. 5 }.....	44
NKF.....	San Diego, California.....	4253.....	70. 5.....	44
NOG.....	Anacostia, District of Columbia.....	4205.....	71. 3.....	44
NPL.....	San Diego, California.....	4182.....	71. 7.....	44
WIR.....	Rocky Point, New York.....	4052.....	74.....	44
SFR.....	Paris, France.....	3998.....	75.....	44
NUQB.....	U. S. S. Pope.....	3988.....	75.....	44
NIRX.....	U. S. S. Canopus.....	3998.....	75.....	44
NAJ.....	Great Lakes, Illinois.....	3945.....	76.....	44
NEV.....	Quantico,, Virginia.....	3874.....	77. 4.....	44
JIAA.....	Iwatuski, Japan.....	3795.....	79.....	44
KFVM.....	S. S. Idalia.....	3748.....	80.....	44
NEL.....	Lakehurst, New Jersey.....	3748.....	80.....	44
2XK.....	Schenectady, New York.....	3748.....	80.....	44
NPG.....	Sanfrancisco, California.....	3701.....	81.....	44
2ZV.....	A. H. Grebe & Co., Inc., New York.....	3701.....	81.....	44
NKF.....	Anacostia, District of Columbia.....	3679.....	81. 5.....	44
RDW.....	Moscow, Russia.....	3612.....	83.....	44
NKF.....	Anacostia, District of Columbia.....	3569.....	84.....	44
SFR.....	Paris, France.....	3527.....	85.....	44
NOG.....	San Diago, California.....	3486.....	86.....	44
KIO.....	Kahuku, Territory, Hawaii.....	3331.....	90.....	44
2YT.....	Poldhu, England.....	3190.....	94.....	44
KEL.....	Bolinas, California.....	3156.....	95.....	44
8XS.....	East Pittsburgh, Pennsylvania.....	3123.....	96.....	44
POX.....	Nauen, Germany.....	2998.....	100.....	44
NAM.....	Norfolk, Virginia.....	2998.....	100.....	44
WGH.....	Rocky Point, New York.....	2911.....	103.....	44
WHU.....	S. S. Big Bill.....	2855.....	105.....	45
2XK.....	Schnectady, New York.....	2751.....	109.....	45
KVFT.....	S. S. Eloise.....	2726.....	110.....	45
KFHV.....	S. S. Fcile.....	2726.....	110.....	45
KFWJ.....	S. S. Gallavant.....	2726.....	110.....	45
1XAO.....	Belfast, Main.....	2677.....	115.....	45
FL.....	Paris, France.....	2607.....	115.....	45
KFWK.....	S. S. Nirvana.....	2607.....	115.....	45
KFVB.....	S. S. Brigedt.....	2700.....	115. 3.....	45

WAVE LENGTH ASSIGNMENTS

Wave Length (Meters)	Frequency (Kilocycles)	CR-18 Coil No.	Type of Transmission	Service
200—150.....	1500—2000.....	#5.....	CW, ICW, Phone	Amateur
150—133.....	2000—2250.....	#5.....		Point to point
133—130.....	2260—2300.....	#5.....		Aircraft only
130—109.....	2300—2750.....	#5.....		Mobile and Gov. Mob.
109—105.....	2750—2850.....	#4.....		Relay Broadcasting
105—85.7.....	2850—3500.....	#4.....		Public toll service, Gov- ernment mobile and point to point com- munication by elec- tric power supply utilities, and point-to- point and multiple address message ser- vice by press organi- zations only.
85.7 —75.0.....	3500—4000.....	#4.....		Amateur
85.66—83.29.....	3500—3600.....	#4.....	Phone.....	Amateur
75.0 —66.3.....	4000—4520.....	#4.....		Public toll service
66.3 —60.....	4520—5000.....	#4.....		Relay Broadcasting
60 —54.5.....	5000—5500.....	#4.....		Public toll service
54.5 —52.6.....	5500—5700.....	#3.....		Relay Broadcasting
52.6 —42.8.....	5700—7000.....	#3.....		Point to point
42.8 —37.5.....	7000—8000.....	#3.....		Amateur
37.5 —33.1.....	8000—9050.....	#3.....		Public toll service
33.1 —30.....	9050—10000.....	#3.....		Relay Broadcasting
30 —27.3.....	10000—11000.....	#2.....		Public toll service
27.3 —26.3.....	11000—11400.....	#2.....		Relay Broadcasting
26.3 —21.4.....	11400—14000.....	#2.....		Public service
21.4 —18.7.....	14000—16000.....	#2.....		Amateur
18.7 —16.6.....	16000—18100.....	#2.....		Public toll service
16.6 —5.35.....	18100—56000.....	#1.....		Experimental
5.35 —4.69.....	56000—64000.....	#1.....		Amateur
4.69 —.7496.....	64000—400000.....	#1.....		Experimental
.7596—.7477.....	400000—401000.....	#1.....		Amateur

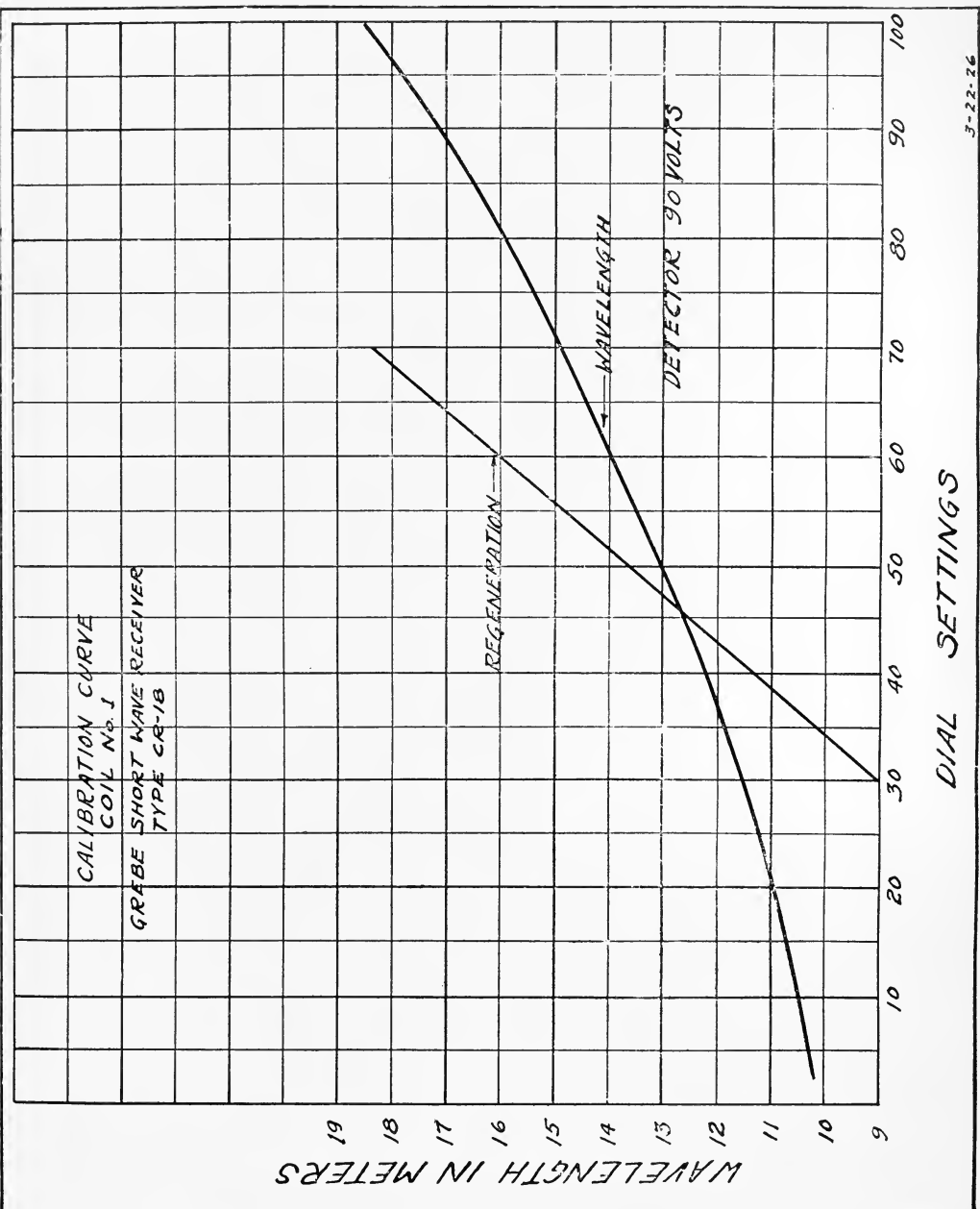

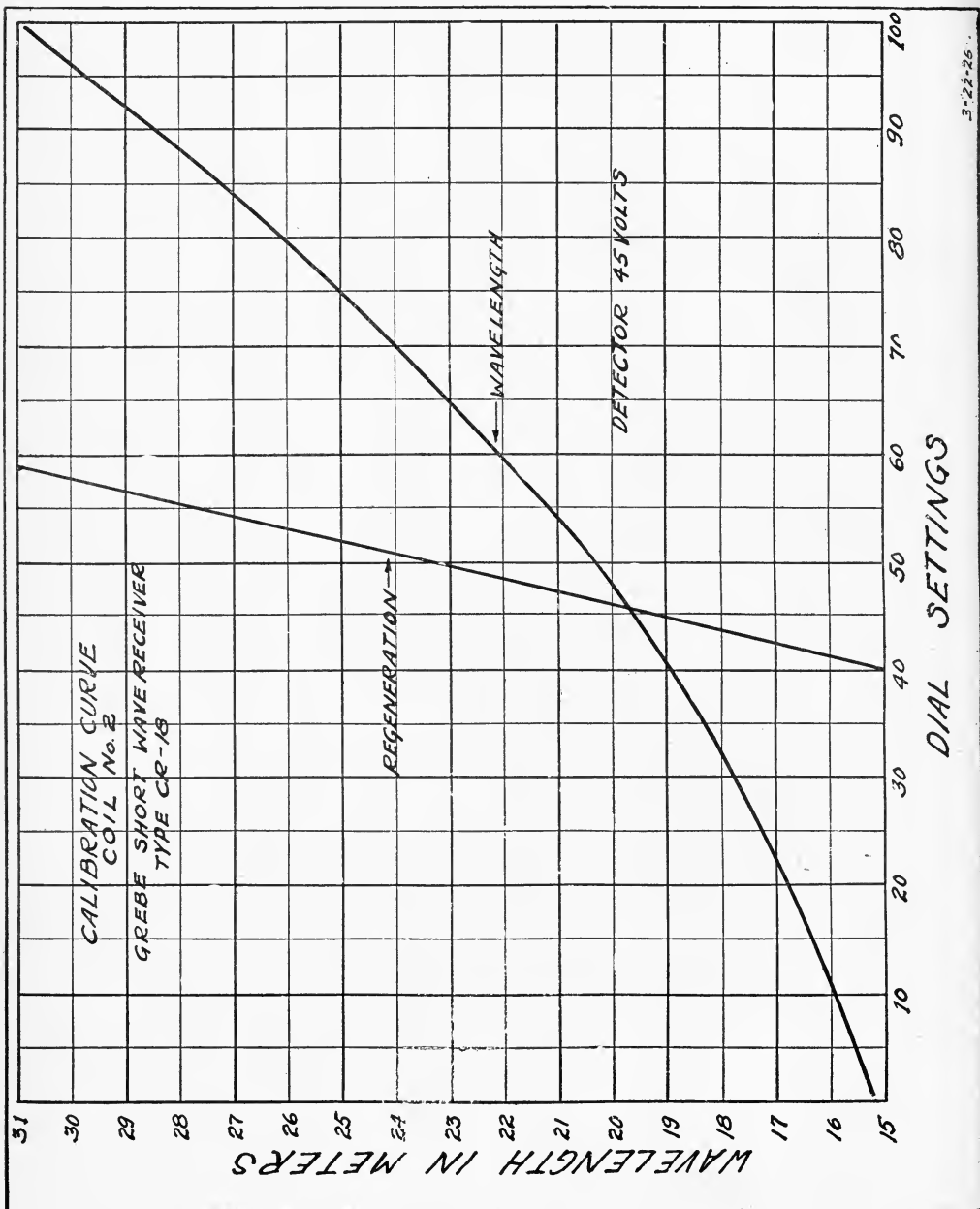

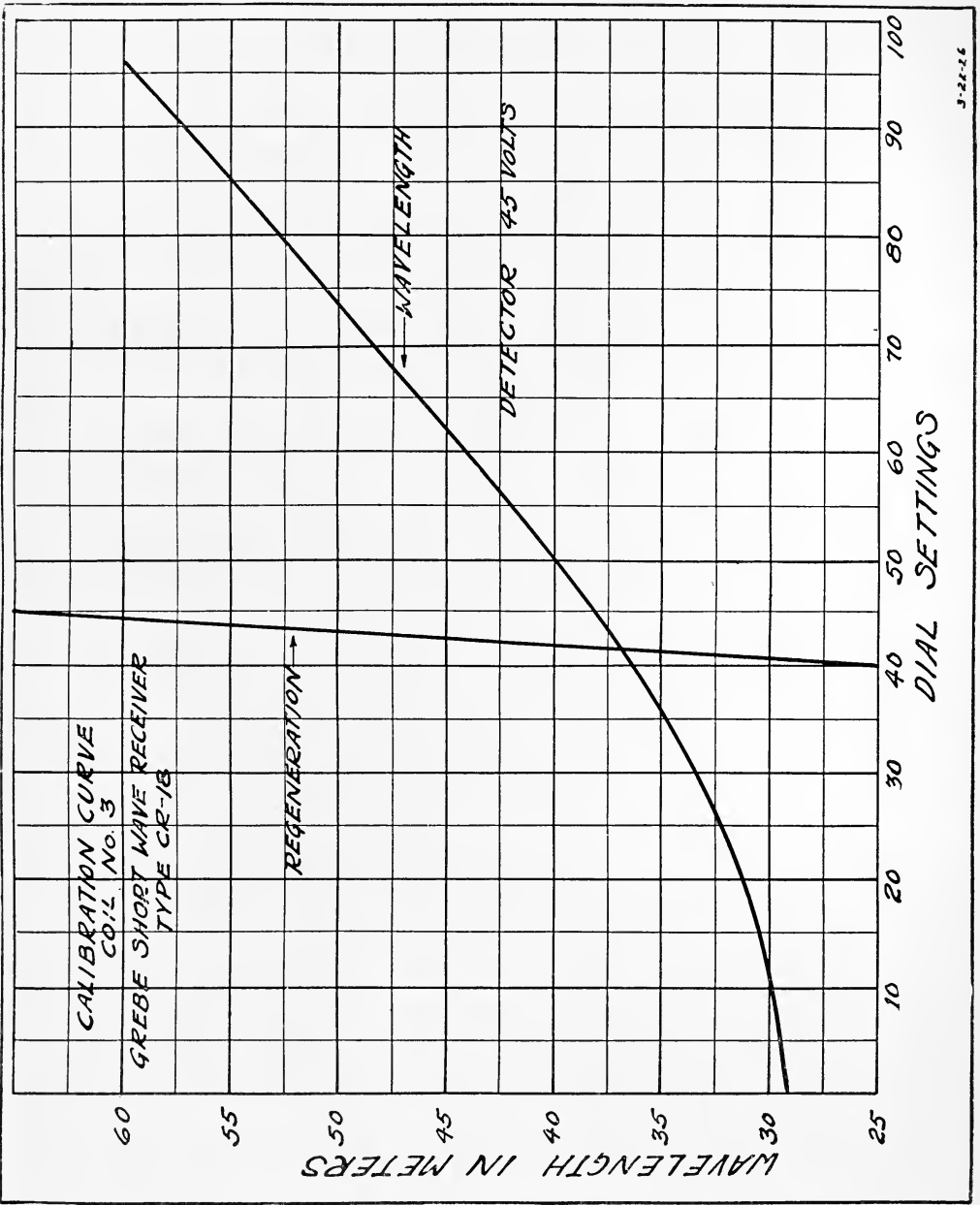

3-24-26

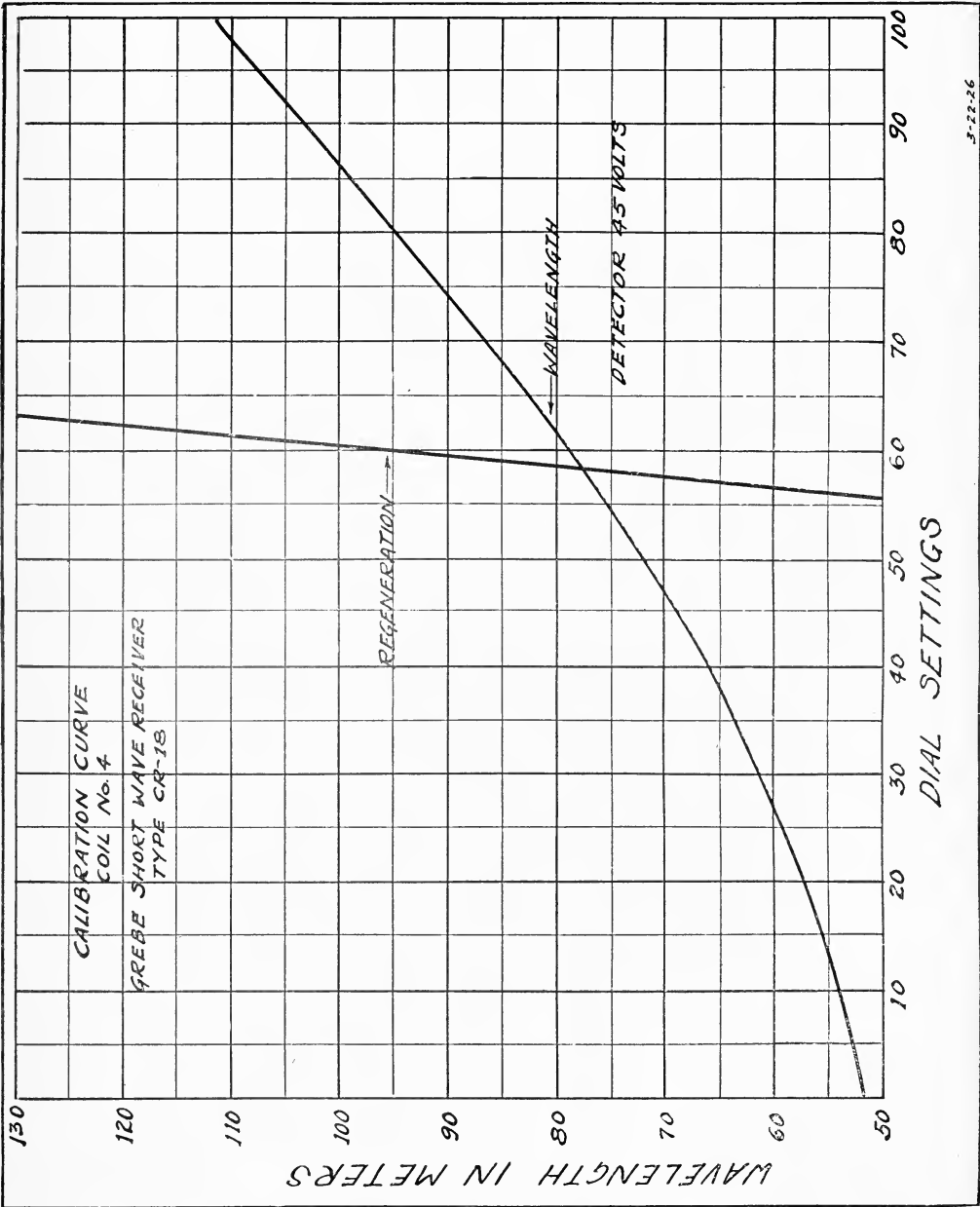

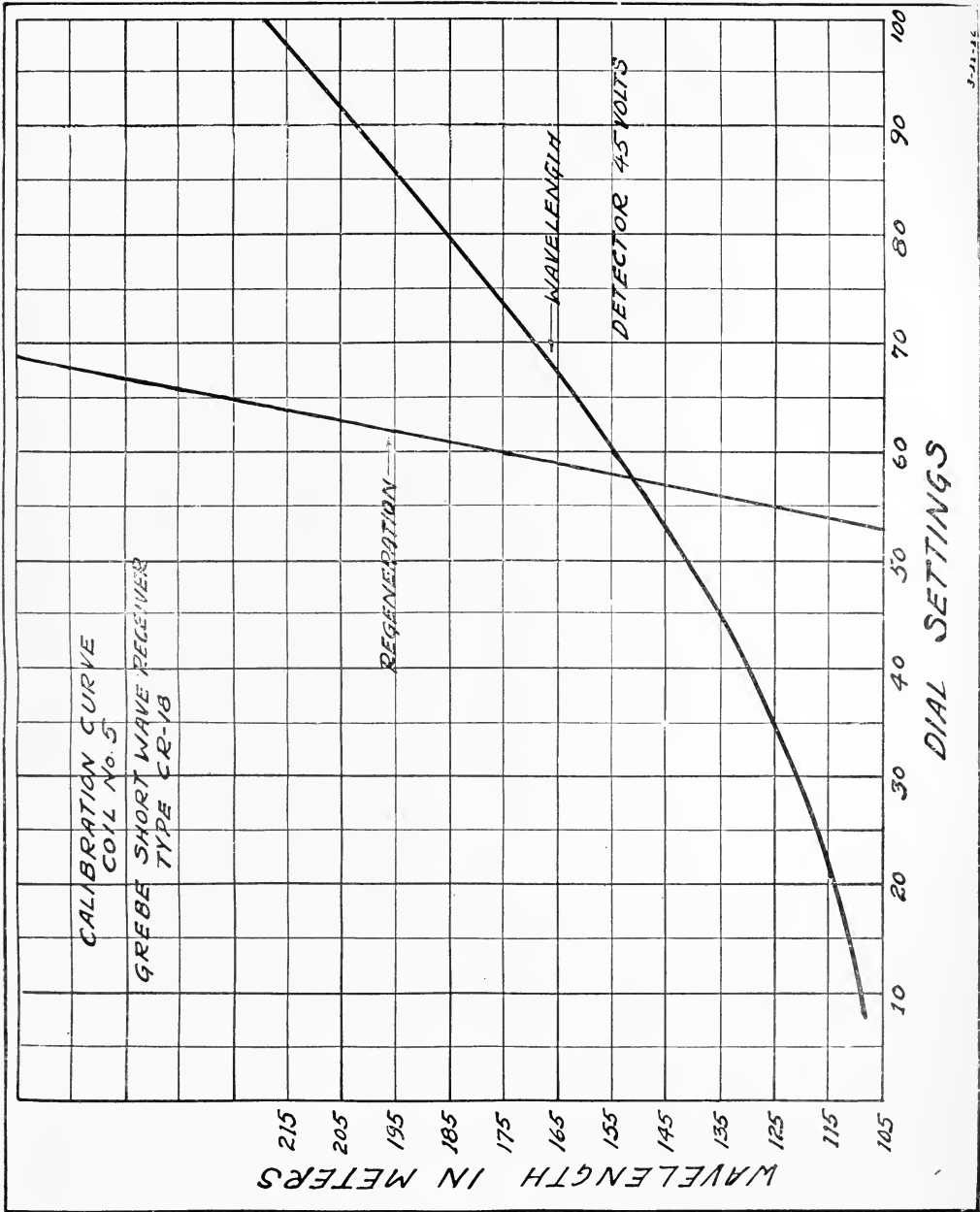

WAVELENGTH-KILOCYCLE

KILOCYCLES TO METERS, OR METERS TO KILOCYCLES

Meters	Kilocycles	Meters	Kilocycles	Meters	Kilocycles	Meters	Kilocycles	Meters	Kilocycles
10.....	29980	520.....	576.6	1030.....	291.1	1540.....	194.7	2050.....	146.3
20.....	14990	530.....	565.7	1040.....	288.3	1550.....	193.4	2060.....	145.5
30.....	9994	540.....	555.2	1050.....	285.5	1560.....	192.2	2070.....	144.8
40.....	7496	550.....	545.1	1060.....	282.8	1570.....	191.0	2080.....	144.1
50.....	5996	560.....	535.4	1070.....	280.2	1580.....	189.9	2090.....	143.5
60.....	4997	570.....	526.0	1080.....	277.6	1590.....	188.6	2100.....	142.3
70.....	4283	580.....	516.9	1090.....	275.1	1600.....	187.4	2110.....	142.1
80.....	3748	590.....	508.2	1100.....	272.6	1610.....	186.2	2120.....	141.4
90.....	3331	600.....	499.7	1110.....	270.1	1620.....	185.1	2130.....	140.8
100.....	2998	610.....	491.5	1120.....	267.7	1630.....	183.9	2140.....	140.1
110.....	2726	620.....	483.6	1130.....	265.3	1640.....	182.8	2150.....	139.5
120.....	2499	630.....	475.9	1140.....	263.0	1650.....	181.7	2160.....	138.8
130.....	2306	640.....	468.5	1150.....	260.7	1660.....	180.6	2170.....	138.1
140.....	2142	650.....	461.3	1160.....	258.5	1670.....	179.5	2180.....	137.5
150.....	1999	660.....	454.3	1170.....	256.3	1680.....	188.5	2190.....	136.9
160.....	1874	670.....	447.5	1180.....	254.1	1690.....	177.4	2200.....	136.3
170.....	1764	680.....	440.9	1190.....	252.0	1700.....	176.4	2210.....	135.7
180.....	1666	690.....	434.5	1200.....	249.9	1710.....	175.3	2220.....	135.1
190.....	1578	700.....	428.3	1210.....	247.8	1720.....	174.3	2230.....	134.4
200.....	1499	710.....	422.3	1220.....	245.8	1730.....	173.3	2240.....	133.8
210.....	1428	720.....	416.4	1230.....	243.8	1740.....	172.3	2250.....	133.3
220.....	1363	730.....	410.7	1240.....	241.8	1750.....	171.3	2260.....	132.7
230.....	1304	740.....	405.2	1250.....	239.9	1760.....	170.4	2270.....	132.1
240.....	1249	750.....	399.8	1260.....	238.0	1770.....	169.4	2280.....	131.5
250.....	1199	760.....	394.5	1270.....	236.1	1780.....	168.4	2290.....	130.9
260.....	1153	770.....	389.4	1280.....	234.2	1790.....	167.5	2300.....	130.4
270.....	1110	780.....	384.4	1290.....	232.4	1800.....	166.6	2310.....	129.8
280.....	1071	790.....	379.5	1300.....	230.6	1810.....	165.6	2320.....	129.2
290.....	1034	800.....	374.8	1310.....	228.9	1820.....	164.7	2330.....	128.7
300.....	999.4	810.....	370.2	1320.....	227.1	1830.....	163.8	2340.....	128.1
310.....	976.2	820.....	365.6	1330.....	225.4	1840.....	162.9	2350.....	127.6
320.....	936.9	830.....	361.2	1340.....	223.7	1850.....	162.1	2360.....	127.0
330.....	908.6	840.....	356.9	1350.....	222.1	1860.....	161.2	2370.....	126.5
340.....	881.8	850.....	362.7	1360.....	220.4	1870.....	160.3	2380.....	126.0
350.....	856.6	860.....	348.6	1370.....	218.8	1880.....	159.5	2390.....	125.4
360.....	832.8	870.....	344.6	1380.....	217.3	1890.....	158.6	2400.....	124.9
370.....	810.3	880.....	340.7	1390.....	215.7	1900.....	157.8	2410.....	124.4
380.....	7879.0	890.....	336.9	1400.....	214.2	1910.....	157.0	2420.....	123.9
390.....	768.8	900.....	333.1	1410.....	212.6	1920.....	156.2	2430.....	123.4
400.....	740.6	910.....	329.5	1420.....	211.1	1930.....	155.3	2440.....	122.9
410.....	731.3	920.....	325.9	1430.....	209.7	1940.....	154.5	2450.....	122.4
420.....	713.9	930.....	322.4	1440.....	208.2	1950.....	153.8	2460.....	121.9
430.....	697.3	940.....	319.0	1450.....	206.8	1960.....	153.0	2470.....	121.4
440.....	681.4	950.....	315.6	1460.....	205.4	1970.....	152.2	2480.....	120.9
450.....	666.3	960.....	312.3	1470.....	204.0	1980.....	151.4	2490.....	120.4
460.....	651.8	970.....	309.1	1480.....	202.6	1990.....	150.7	2500.....	119.9
470.....	637.9	980.....	305.9	1490.....	201.2	2000.....	149.9	2510.....	119.5
480.....	624.6	990.....	302.8	1500.....	199.9	2010.....	149.2	2520.....	119.0
490.....	611.9	1000.....	299.8	1510.....	198.6	2020.....	148.4	2530.....	118.5
500.....	587.9	1010.....	296.9	1520.....	197.2	2030.....	147.7	2540.....	118.0
510.....	587.9	1020.....	293.9	1530.....	196.0	2040.....	147.0	2550.....	117.6

The values given in the table were computed using the factor 299,820,000 meters per second as the speed of the electro-magnetic wave. The formula

Speed

$$\text{from which the values were derived is—Frequency} = \frac{\text{Wavelength}}{\text{Speed}}$$

As the values given in the table are convertible, wherever a value of frequency appears it is interchangeable with the value of wavelength associated with it, and vice versa.

For example what is the wavelength corresponding to 1,500 kilocycles? Under the column headed "Kilocycles," the value of 1,500 is not shown; however, the value of 1,500 may be located under the "Wavelength" column, and it will be seen that a value of 199.9 is given. The wavelength, then corresponding to 1,500 kilocycles is 199.9 meters. Broadcasting stations are assigned frequencies between 1,500 and 550 kilocycles, each station being separated by ten kilocycles. In order to determine the correct wavelength of the broadcasting stations, simply refer to the column headed "Meters" and, starting at 1,500, assume all values of wavelengths to be frequency values in kilocycles and vice versa. Running down the column would give us 550 kilocycles equals 545.1 meters; 560 kilocycles equals 535.4 meters; 570 kilocycles equals 526 meters, etc.

By using the decimal point correctly, the table may be extended to include values not given, remembering that as the wavelength is increased the frequency is lowered.

CONVERSION TABLE

KILOCYCLES TO METERS, OR METERS TO KILOCYCLES

Meters	Kilocycles	Meters	Kilocycles	Meters	Kilocycles	Meters	Kilocycles	Meters	Kilocycles
2560.....	117.1	3080.....	97.34	4060.....	73.85	5100.....	58.79	7350.....	39.71
2570.....	116.7	3100.....	96.72	4080.....	73.49	5120.....	59.22	7600.....	39.45
2580.....	116.2	3120.....	96.10	4100.....	73.13	5200.....	57.66	7650.....	39.19
2590.....	115.8	3140.....	95.48	4120.....	72.77	5250.....	57.11	7700.....	38.94
2600.....	115.3	3160.....	94.88	4140.....	72.42	5300.....	56.57	7750.....	38.69
2610.....	114.9	3180.....	94.28	4160.....	72.07	5350.....	56.03	7800.....	38.44
2610.....	114.9	3200.....	92.69	4180.....	71.73	5400.....	55.52	7850.....	38.19
2620.....	114.4	3220.....	93.11	4200.....	71.39	5450.....	55.01	7900.....	37.95
2630.....	114.4	3240.....	92.54	4220.....	71.05	5500.....	54.51	7950.....	37.71
2640.....	113.6	3260.....	91.97	4240.....	70.71	5550.....	54.02	8000.....	37.48
2650.....	113.1	3280.....	91.41	4260.....	70.38	5600.....	53.54	8050.....	37.25
2660.....	112.7	3300.....	90.86	4280.....	70.05	5650.....	53.07	8100.....	37.02
2670.....	112.3	3320.....	90.31	4300.....	69.73	5700.....	52.60	8150.....	36.79
2680.....	111.9	3340.....	89.77	4320.....	69.40	5750.....	52.14	8200.....	36.56
2690.....	111.5	3360.....	89.23	4340.....	69.08	5800.....	51.69	8250.....	36.34
2700.....	111.0	3380.....	88.70	4360.....	68.77	5850.....	51.25	8300.....	36.12
2710.....	110.6	3400.....	88.18	4380.....	68.45	5900.....	50.82	8350.....	35.91
2720.....	110.2	3420.....	87.67	4400.....	68.14	5950.....	50.39	8400.....	35.69
2730.....	109.8	3440.....	87.16	4420.....	67.83	6000.....	49.97	8450.....	35.48
2740.....	109.4	3460.....	86.65	4440.....	67.53	6050.....	49.56	8500.....	35.27
2750.....	109.0	3480.....	86.16	4460.....	67.22	6100.....	49.15	8550.....	35.07
2760.....	108.6	3500.....	85.66	4488.....	66.91	6150.....	48.75	8600.....	34.86
2770.....	108.2	3520.....	85.18	4500.....	66.63	6200.....	48.36	8650.....	34.66
2780.....	107.8	3540.....	84.70	4520.....	66.33	6250.....	47.97	8700.....	34.46
2790.....	107.5	3560.....	84.22	4540.....	66.04	6300.....	47.59	8750.....	34.27
2800.....	107.1	3580.....	83.75	4560.....	65.75	6350.....	47.22	8800.....	34.07
2810.....	106.7	3600.....	83.28	4580.....	65.46	6400.....	46.85	8850.....	33.88
2820.....	106.3	3620.....	82.82	4600.....	65.18	6450.....	46.48	8900.....	33.69
2830.....	105.9	3640.....	82.37	4620.....	64.90	6500.....	46.13	8950.....	33.50
2840.....	105.6	3660.....	81.92	4640.....	64.62	6550.....	45.77	9000.....	33.31
2850.....	105.2	3680.....	81.47	4660.....	64.34	6600.....	45.43	9050.....	33.13
2860.....	104.8	3700.....	81.03	4680.....	64.06	6650.....	45.09	9100.....	32.95
2870.....	104.5	3720.....	80.60	4700.....	63.79	6700.....	44.75	9150.....	32.77
2880.....	104.1	3740.....	80.17	4720.....	63.52	6750.....	44.42	9200.....	32.59
2890.....	103.7	3760.....	79.74	4740.....	63.25	6800.....	44.09	9250.....	32.41
2900.....	103.4	3780.....	79.32	4760.....	62.99	6850.....	43.77	9300.....	32.24
2910.....	103.0	3800.....	78.90	4780.....	62.72	6900.....	43.45	9350.....	32.07
2920.....	102.7	3820.....	78.49	4800.....	62.46	6950.....	43.14	9400.....	31.90
2930.....	102.3	3840.....	78.08	4820.....	62.20	7000.....	42.83	9450.....	31.73
2940.....	102.0	3860.....	77.67	4840.....	61.95	7050.....	42.53	9500.....	31.56
2950.....	101.6	3880.....	77.27	4860.....	61.69	7100.....	42.23	9550.....	31.39
2960.....	101.3	3900.....	76.88	4880.....	61.44	7150.....	41.93	9600.....	31.23
2970.....	100.9	3920.....	76.49	4900.....	61.19	7200.....	41.64	9650.....	31.07
2980.....	100.6	3940.....	76.10	4920.....	60.94	7250.....	41.35	9700.....	30.91
2990.....	100.3	3960.....	75.71	4940.....	60.69	7300.....	41.07	9750.....	30.75
3000.....	99.44	3980.....	75.33	4960.....	60.45	7350.....	40.79	9800.....	30.59
3020.....	99.28	4000.....	74.96	4980.....	60.20	7400.....	40.52	9850.....	30.44
3040.....	98.62	4020.....	74.58	5000.....	59.96	7450.....	40.24	9900.....	30.28
3060.....	97.98	4040.....	74.21	5050.....	59.37	7500.....	39.98	9950.....	30.13

Example 1.

What is the frequency corresponding to 10,000 meters? The highest wavelengths shown in the table is 9,950 meters. However, by referring to 1,000 meters we find the value of 299.8 kilocycles. As 10,000 meters is higher than 1,000 meters, we simply divide 299.8 by ten, or move the decimal point one place to the left, which gives us 29.98 kilocycles.

Example 2.

What is the frequency corresponding to 346 meters? Under the wavelength column no value is shown for wavelengths between 340 and 350 meters; however, referring to 3,460 meters the value of 86.65 kilocycles is shown. Multiplying this value by ten, or moving the decimal point one place to the right, results in a value of 866.55 kilocycles, which corresponds to 346 meters.

Example 3.

What is the frequency corresponding to 37.48 meters? In the column headed "Meters," no value is found for 37.84 meters. If we refer to 3,784 meters we find that the nearest value is 3,750. However, by looking under the column headed "Kilocycles," we find the value of 374.8, which equals 800 meters. This is equivalent to 374.8 meters equals 800 kilocycles. By multiplying 800 by ten, we obtain 8,000 kilocycles for the equivalent frequency of 37.48 meters.

SUPER - 10

The Norden Hauck Super-10 is a custom built broadcast receiver having a total of 10 tubes arranged as follows: five tuned radio frequency stages, detector and four audio frequency stages. Five of the six tuning variable condensers are mounted as a single unit on a common shaft. This system of construction requires very carefully adjusted condensers and accurately matched radio frequency transformers. An individual tuning condenser is used for the antenna stage, making a total of two controls.

The idea of five tuned radio frequency stages is partly for maximum sensitivity and also for maximum selectivity, the multiple condenser enables an arrangement which is decidedly easy to operate.

As may be guessed, from the individuality of design form, the writer did a large part of the design and development work on this model and the special B-C Current Supply for same. In working out this design the experience obtained from the Super Pliodyne 9 was used to advantage as the tube arrangement was the same with the exception of one additional audio stage.

In the Super-10 a more modern system of tube neutralization is employed, the greater part of the neutralization being due to the radio frequency transformer design. In addition a small series grid damping resistor is used, the receiver is non-regenerative over the entire wavelength scale.

The radio frequency transformers are of the interchangeable type, the size accompanying the receiver tune from 200 to 560 meters. The smaller sizes tune down to 35 meters and the larger type tuning up to 3,600 meters. For experimental work the receiver can be used as an intermediate amplifier in connection with a Frequency Changer for the reception of still shorter wavelengths, down to 20 meters or lower.

An experimental Frequency Changer designed and built for these experiments is shown in the accompanying illustrations. The wiring is practically the same as for the other type Frequency Changer designs shown in this book.

The four stage audio amplifier is arranged to use either a UX171 or UX210 in the power stage. Using a UX210, the Special Power Pack should be used to secure the desired voltages, etc. The Power Pack in addition to supplying the voltages for the radio frequency amplifier,



Front View 10-Tube N-H Super-10 Broadcast Receiver.

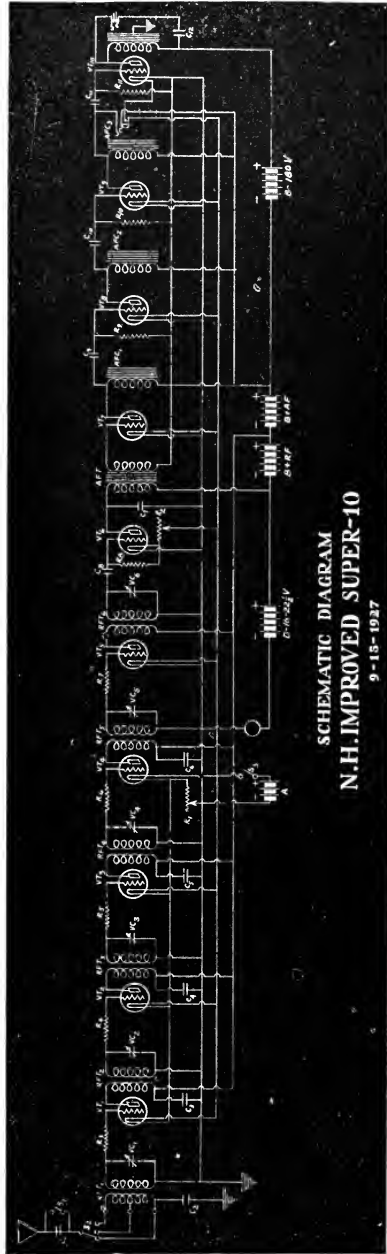

Wiring Diagram N-H Super-10.

detector, and audio amplifier, also supplies $7\frac{1}{2}$ volts "A," 400 volts "B" and 40 volts "C" for the power audio tube. The "A" current supplied is of course alternating current, which is suitable for the power tube filament. The Power Pack has a multiple circuit switch and rear power outlet for the charger so that the battery charging is automatically taken care of when the receiver is turned off. An "A" eliminator may be used if the capacity is 3 amperes at 6 volts.

Referring to the front view illustration, the left Selector tunes the antenna circuit (or loop) and the right Selector tunes the radio frequency amplifier bank, these are the two principal tuning operations. A selector switch is provided at the extreme left hand end of the receiver to control the degree of selectivity, this can be used in connection with an antenna series switch for still further selectivity. Regulating rheostats are provided for the Detector Tube and Radio Frequency Tubes, the latter in a group. A Weston two-scale meter together with a 9 reading meter switch gives all the "A," "B" and "C" readings required. When reading the power tube "B" voltage, the top scale has to be multiplied by a factor, the exact value as stated in the instructions accompanying the receiver.

The Milliammeter gives the total "B" consumption from the "B" batteries or Power Pack, the readings on this meter are useful for checking the operation of the various tubes.

By removing one tube at a time, the exact amount of "B" current taken by each tube will be noted. If no "B" current is being taken by the tube, the tube emission has either stopped or the plate circuit of that tube is open.

This method of testing any receiver can be followed by connecting a 0 to 50 or 0 to 100 milliammeter in series with the common "B" negative lead to the receiver. Care must be taken not to allow a direct potential across the milliammeter or it will be immediately burnt out.

The UX200̄ detector is particularly recommended for this set, due to the desirable features of this tube, viz., non-microphonic, extra sensitivity, controlled volume, etc. The UX200A tube may be used if desired, in which case the "B" voltage should be increased from $22\frac{1}{2}$ to 45 or $67\frac{1}{2}$ volts until best results are secured.

Shielding between the radio frequency transformers is not used. The fields of the different transformers are pointed in different directions so that a minimum of interaction takes place, this is accomplished by

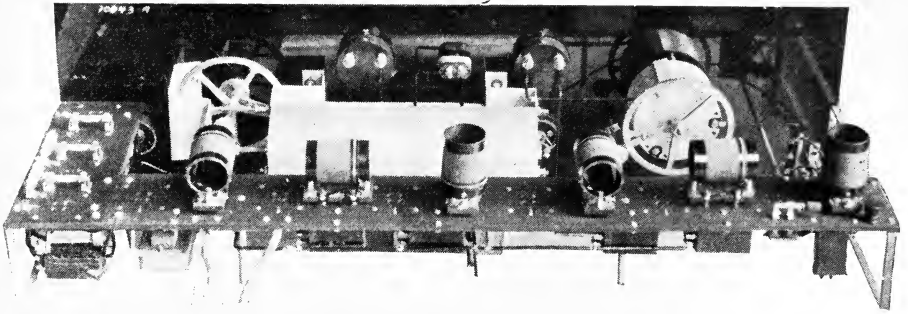

Super-10—Rear View, Cabinet removed.

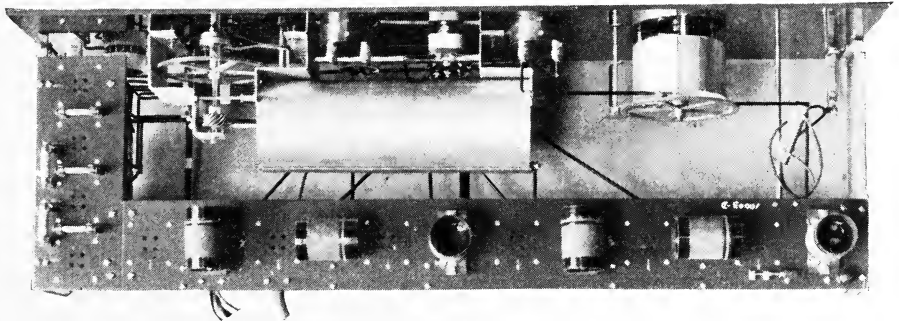

Super-10—Plan View, note Gearing on large condenser.

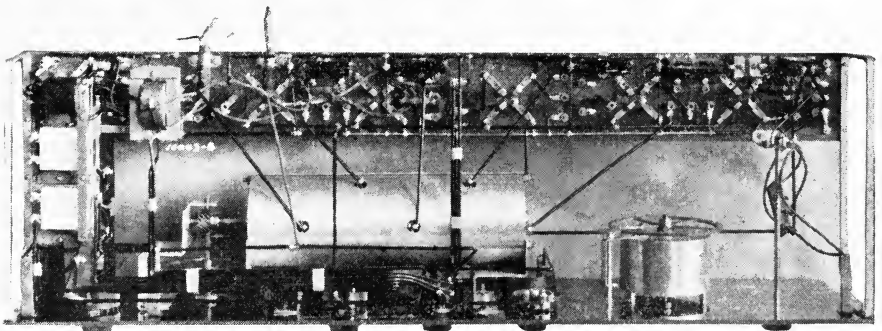

Super-10—View looking at the bottom.

the different positions of the transformers as will be noted in the photos shown.

The variable tuning condensers are elaborately shielded. Each stator is shielded from the adjoining stator, this is also true of each condenser. The entire condenser is shielded. As the condenser is at right angles to the control drive shaft, a 1-1 spiral gear system is used to change the drive direction. There is also a geared reduction of 6 to 1 from the condenser shaft to the Selector tuning control on both condensers, providing a fine tuning adjustment in each case.

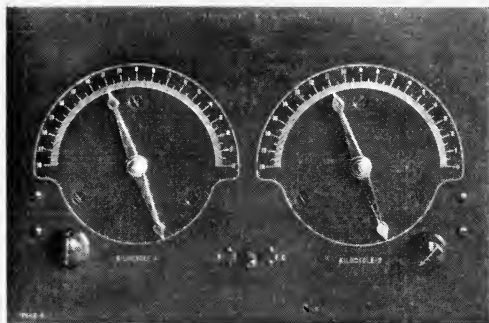

Front View, Frequency Changer for N-H Super-10, the center switch cuts the F-C in or out of circuit as required.

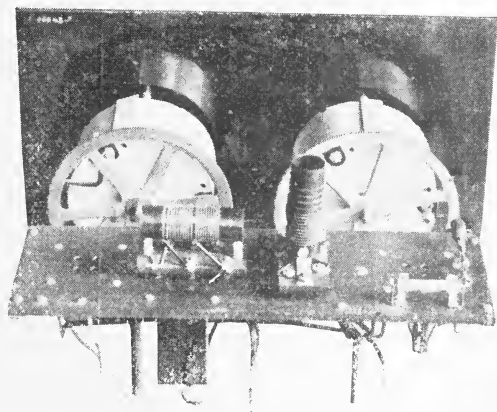

Internal View, Frequency Changer. Note: Inductances are interchangeable to cover all low waves. The two tubes are not shown.



Power Pack, N-H, for the Super-10, output 400 volts 60 M.A.

The audio, radio and detector voltage are variable thru the three adjustments provided.

Either one UX216B or UX281 Rectifier tube may be used.

N-H B-C Current Supply.

PHONOGRAPH PICK-UPS

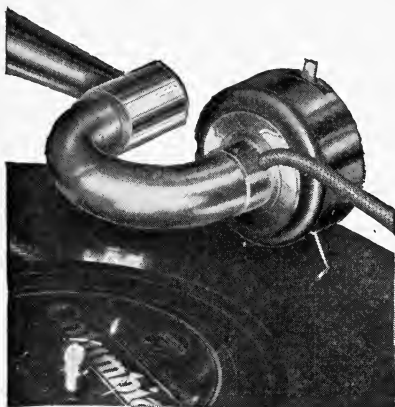

With a simple Phonograph pick-up device, the powerful audio amplifier and modern loud speaker of a good radio receiver may be used to give perfect electrical reproduction of ordinary phonograph records. The illustration shows one of the many types of pick-ups available. There are different types; magnetic, microphonic, condenser type, etc. The type made by Amplion is one of the best and easily adapted to any phonograph and radio as no alterations or switches are required. The pick-up device is mounted

on the phonograph without interfering with the phonograph mechanism at all, from this device a long cord extends to the radio receiver. At the end of this cord is a plug, similar to a tube base, which is inserted in the receiver in place of the detector tube. A volume control is included to regulate the record reproduction to the desired intensity.

When using this device in connection with a receiver which is operated by a power pack, it is well to leave the radio frequency tubes burning dim; to turn the radio frequency tubes completely out may cause the radio frequency plate voltage to raise to an abnormal value which in turn may damage the radio frequency by-pass condensers. Radio signals can be excluded by de-tuning the antenna dial of the receiver. In case the receiver has an exceptionally powerful audio amplifier, the plug of the pick-up can be inserted in the first audio socket instead of the detector socket. This device used in connection with the UX210 push-pull amplifier of a Silver Ghost receiver and good loud speaker gives electrical reproduction of the phonograph records equal to the most expensive electric phonographs.

MODERN RADIO RECEPTION**Dynamotors**

In many cities the house lighting electric lines are 110 volt direct current. A and B eliminators to operate from 110 volts direct current are described in this book but it will be noted that it is impossible to secure a higher voltage from such eliminators than the line voltage. It is impossible to step up direct current through the use of a transformer. It is sometimes possible to secure 220 volts direct current from the 110 volt three wire systems by having the electric company approve installing a special line from the meter switch box to the radio. This allows using a 220 volt d.c. eliminator which will deliver at least 180 volts and operate a UX171 power tube.

However the most efficient A and B eliminators operate from alternating current usually 110 volts 60 cycles. To use these eliminators at a location where the power lines are direct current, it is necessary to change the direct current to alternating current. This can be accomplished by using a dynamotor. A dynamotor is similar to a motor, but has extra collector rings mounted at one end, one end of this device is a motor and the other end a generator, the device runs off the 110 volt direct current lines and delivers 110 volts 60 cycles alternating current. This alternating current can be used to run the regular alternating current A and B eliminators.

It is suggested that the dynamotor be located in the basement of the house and controlled from a remote control switch at the receiver. In the case of an apartment, the dynamotor could be located in a closet where it would be out of the way. These dynamotors come equipped with and without filters; the filter should always be included when the dynamotor is used to operate radio devices. The dynamotor does not require any more care than a small motor, occasional oiling.

MODERN RADIO RECEPTION

Dynamic Loud Speakers



There is a limit to the volume that can be reproduced by any ordinary loud speaker, without causing distortion. In order to have the loud speaker sensitive to weak signals, the speaker unit armature must be placed reasonably close to the pole pieces. Accordingly when receiving unusually strong signals, there is such a wide movement of the armature that it strikes the pole pieces causing distortion. In the dynamic loud speaker, the armature is simply a few turns of wire wound on a diameter of approximately 1 inch and a length of $\frac{1}{4}$ inch. This winding fits over the pole piece. This winding has a wide and free movement concentric with the pole piece and cannot strike anything, accordingly the volume can be increased to the limit that the power tube will handle without distortion, the speaker itself being practically free from distortion due to mechanical limitations. This type of speaker will become more and more popular when its superiorities are recognized.

Chapter IV

RADIO TUBE DATA

The following data relates specifically to Cunningham radio tubes. Radio Corporation tubes of corresponding type numbers have practically the same characteristic

These instructions apply to ordinary every day use. In advanced radio receivers the instructions for tubes may differ, this difference being taken care of in the receiver design.

The Symbols and Abbreviations used with reference to these tubes are as follows:—

- E(f) Filament Voltage
- I(f) Filament Current
- E(p) Effective plate voltage measured with respect to negative filament terminal.
- I(p) Plate Current (Milliamperes)
- E(g) Grid voltage measured with respect to negative filament terminal.
- I(g) Grid Current, usually measured in microamperes.
- I(s) Emission Current (milliamperes)
- Mu Amplification Constant.
- R(p) Plate Impedance ohms (not resistance of tube to D. C. currents)
- G(m) Mutual Conductance (microhms)
- R(l) Load Resistance (ohms)

REACTIVATION OF THORIATED TUNGSTEN FILAMENT

The Thoriated Tungsten Filament—How it Operates

The thoriated tungsten filament is used in the following types of Cunningham Radio Tubes: C and CX-299, CX-220, CX-300A, CX-301A, CX-371, CX-310, CX-313 and CX-316B. This filament is not of the coated type, the thorium content being distributed throughout the body of the tungsten wire. In the final factory process, a uniform layer of atomic thorium is built up on the surface of the filament, this layer being responsible for the high emission efficiency of the thoriated filament. When the tube is in use this surface layer of thorium very gradually evaporates, but just as rapidly fresh thorium is continuously supplied from the interior of the filament. This process continues very smoothly maintaining an active surface condition throughout the life of the tube provided the filament voltage is not increased more than 10% above the rated value. When subjected to a voltage overload, this balance between surface evaporation and restoration is upset, the active thorium surface is destroyed and the filament emission rapidly decreases. In

operation the tendency is to further increase the filament voltage, thus further overloading the tube until no emission is obtained. The tube filament is then said to be "paralyzed" but can be restored by reactivation.

The end of normal life of the thoriated tungsten filament results from the exhaustion of the thorium content and is indicated by a sudden decrease in filament emission instead of actual failure or burnout of the filament as with other types of filament material.

When to Reactivate

The filament condition of a tube may be most readily judged by an emission test using the circuit shown in Fig. 3, Plate 25. The voltages specified should not be exceeded. Higher voltages will permanently damage the vacuum and may even result in a burnout. If the emission is above the minimum value specified below, the tube is in good condition and does not need reactivation. If equipment for reading emission is not available a simple test for the most widely used tube types can be made on the customary tube test set which measures plate current. This circuit is shown in Figure 1, Plate 25.

For C or CX-299 tubes, set the plate voltage at 45 volts with the grid connected to the negative filament, set the negative voltage at 3 volts and read the plate current. **Momentarily** increase the filament voltage to 3.5 and read the plate current. If the plate current increases more than .2 milliamperes, the filament is not fully active and the tube may be improved by the reactivation process.

Type No.	Voltage	Voltage	Emission	Voltage	Voltage
C—CX 299	3.3	50	6 mamp.	4.0	12
CX 220	3.3	50	15	4.0	12
CX 301A	5.0	50	25	7.0	18
CX 300A	5.0	50	12	7.0	18
CX 371	5.0	50	50	7.0	18
CX 310	6.0	100	100	9.0
CX 313	4.0	100	50 per anode	6.0
CX 316B	6.0	125	100	9.0

For C or CX-301-A tubes, the same value of plate voltage (45) is used but the plate current is read with the filament voltage set at 4 and 6. An increase of more than .2 milliamperes in the plate current indicates that the tube may be improved by reactivation.

If the tube will not return to normal after reactivation treatment, it is proof that the tube has either served its normal life or has been so heavily overloaded that the thorium content has been exhausted or the vacuum impaired.

How to Reactivate—Two Methods

The following methods will generally restore the emission, that is, reactivate, tubes which have been overloaded and also, at times, will reactivate, for short additional usage, tubes that have dropped in emission at the end of normal life. The exact process which gives best results depends upon the nature and extent of the overload to which the tube has been subjected.

RADIO TUBE TEST LIMITS*							
	C-CX 11-12	C-CX 299	CX-220	C1CX 301A	CX-112	CX-371	CX-310
I(f) (m.a.)	237-262	57-63	119-131	237-262	475-525	475-525	1190-1310
I(p) m.a.) Min.		1.0	.90	4.5	.95	5.0	12.
Mu Min.		5.0	5.0	2.9	6.5	6.5	2.7
							7
							8000
R(p) (ohms) Max.		20,000	25,000	8500	20,000	8000	4000
Gm Min.		300	300	400	450	1200	1200
							1000
Use following voltages in reading I(f), I(p), Mu, R(p), Gm:							
I(s) (m.a) Min.		6.0	6.0	16.0	20.0	50.0	50
E(f)		1.1	3.3	3.3	5.0	5.0	5.0
E(g)		0.0	0.0	22.5	0.0	9.0	27
E(p)		40.0	40.0	135.0	40.0	135.0	135
							425.0
Use following voltages in deaing Emission I(s):							
Use the following voltages in reading Emission I(s):							
E(f)		1.1	3.3	3.3	5.0	5.0	5.0
E(p+g)		50.0	50.0	50.0	50.0	50.0	50.0
							100.0

NOTE:—E(p+g) indicates that the specified voltage is applied to the grid and plate connected together as an anode. The emission current is the total current flowing to both electrodes read by milliammeter in the common lead.

*All values subject to revision without notice.

Tubes which have been subjected to only a slight overload may be reactivated by a very simple process. This consists of burning the filament, with the plate voltage disconnected, at the voltage listed above under the heading "Reactivation Voltage." This process speeds up the "boiling out" of the thorium from the body of the wire, while at the same time the surface evaporation is very slow when plate voltage is not applied. The length of time required to reactivate a tube by this treatment is one-half to one and one-half hours, depending largely upon the length of time and the extent to which the tube has been subjected to excessive voltage. At the end of thirty minutes burning, test the tube as explained above. If the emission shows improvement continue the treatment until test shows the tube to be above minimum passing limit.

Tubes which have been badly overloaded may not improve under this process, and a "flashing" voltage must be used, as outlined below:

First burn the filament for 10 to 20 seconds at the voltage shown in the table under the heading "Flashing Voltage." Then burn the Filament Grid and Plate Minimum filament under the process described above, using the voltage listed as "Reactivation Voltage." Read the

emission at the end of thirty minutes and if not restored, continue to burn the filament up to 2 hours, taking readings every thirty minutes. If two hours' treatment does not restore the emission, or greatly improve it, it is proof the tube cannot be reactivated.

No plate voltage is ever applied during the reactivation.

The applied voltages should always be controlled by a suitable voltmeter.

A small percentage of tubes reactivated by the use of flashing voltages may be expected to burn out during treatment.

Rapid reactivation, sometimes within ten minutes, can be accomplished by the use of voltages higher than those recommended above. This process very materially shortens the life and such reactivation is generally not permanent. Furthermore, the use of higher voltages greatly increases the percentage of tubes that burn out. Reactivation by the "while you wait" process cannot be recommended.

Reactivation Equipment:

Alternating current from the lighting supply is most convenient and can be stepped down to the proper voltages by a toy or bell ringing transformer, such as, G.E. Type No. 236093 which is provided with two volt taps from 4 to 22 volts. The circuit diagram is shown in Plate 26 & 2'. As A.C. voltmeters require considerable current they should be left permanently in circuit in parallel with the tubes.

If alternating current is not available D.C. supplied by storage batteries may be used. The flashing voltage may be obtained from a storage B battery of the larger sizes. Only one tube should be flashed at a time on a B storage battery and the battery must be left fully charged. The circuit for battery operation is shown in Plates 26 & 2'.

FREQUENT REACTIVATION PROOF OF IMPROPER OPERATION

Cunningham Radio Tubes are designed to deliver at full efficiency throughout normal life provided operation is at rated voltages. No reactivation is necessary. This is well illustrated by the curve in Plate 26, showing the mutual conductance of a standard CX-301-A tube on life test at rated voltages. This curve is representative of the life performance of Cunningham Radio Tubes and shows practically no change in performance up to 1500 hours. The test was discontinued at this time since 1500 hours is equal to approximately two years of service under average conditions. Such life is only obtained from tubes which are not overloaded or abused. The increased life and satisfaction obtainable when rated voltages are used, together with the saving in battery current, justifies the use of a filament voltmeter. This is es-

pecially desirable with multiple tube sets using Types C-299, CX-299 and CX-220.

If it is necessary to reactivate tubes each month or at frequent intervals, it is proof that the tubes are being overloaded, and in such cases users can be assisted to obtain satisfactory service by having their attention called to the following:

1. Do not burn the filament at voltages in excess of the rated filament terminal voltage. Keep the filament rheostat set as low as possible, or use a reliable voltmeter.

2. Do not use high plate voltages unless "C" batteries are provided. With types C-299, CX-299 and CX-301A better life is obtained, and B battery current drain lessened, when a voltage of $67\frac{1}{2}$ volts or less is used in the plate circuit in case no C battery is provided.

3. Be careful when changing battery connections to see that battery polarities are not reversed. If the leads connecting filament heating (A) or grid biasing (C) battery are reversed, signals and music may still be heard, but they will be faint or distorted. Such a reversed condition often causes the operator to turn the filament to a high setting, thus injuring the tubes without appreciably improving results. Always check battery connections after making any changes.

4. If an insensitive tube and a tube in perfect condition are operated from the same rheostat, there will be a tendency to overload the good tube in order to obtain operation from the poorer one. The poor tube should be reactivated or replaced. Here again, the use of a reliable filament voltmeter will save overloading the tubes.

5. If a set without filament voltmeter is equipped with a rheostat volume control which operates by reducing the filament temperature of one or more tubes, this control should always be set to the "Full" or "On" position when adjusting the filament rheostat. If not set on the "Full" position an increase in the filament voltage will increase the audibility of the set at the same time overloading the tubes not controlled by the volume rheostat.

6. When using C-299, CX-299 or CX220 and a filament voltmeter is not available, the operation of the set may be checked as follows: Connect **only two** fresh dry cells in series for use as the filament heating (A) battery. The rheostats may now be turned full on, and if the set and tubes are operating correctly, satisfactory reception will be obtained. If results are not satisfactory, check over batteries, battery connections, antenna connections and tubes. When the trouble is located, satisfactory reception will be obtained with the two fresh cells.

General Comment

Many of the standard types of tube rejuvenators use excessive voltage with the frequent result that the tube is permanently damaged or has its useful life shortened. This is especially true with the C-299, CX-299 and CX-220 tubes. With these tubes, the second burning voltage should not exceed 4.0 volts.

The voltages specified in the table are the maximum which should be used. The use of a voltmeter to set the applied voltages to the proper values is essential to obtain proper results.

Tubes which have internal shorts between elements cannot be reactivated and it may be convenient to check for such conditions with a pair of phones and a dry cell. When the tube is not lighted there should be an open circuit between the grid and all other elements, between the plate and all other elements and a closed circuit through the filament.

Tubes in which the vacuum is impaired cannot be reactivated. This is usually indicated by a filament current reading above rated value. If considerable air is present in the tube, the filament will not light up at all unless the filament voltage is raised well above normal, in which case the filament may burn out.

Cunningham Radio Tubes Type C-11, CX-12, CX-112 and CX-300 do not use the thoriated tungsten filament and cannot be reactivated.

TYPES C-11 AND CX-12

Cunningham Radio Tubes Types C-11 and C-12 are identical in internal construction but mounted on different bases. They are designed for detection and audio frequency amplification, primarily in dry battery operated receivers with limited outputs. The filament voltages of 1.1 volts permits the filament circuit to be energized by a single No. 6 dry battery, a particular advantage in one to three tube portable sets.

C-11 has a special push type designed to prevent insertion of the tube into a standard socket which may be connected to a 6 volt source of supply. The CX-12 tube is interchangeable in the "CX" type socket and care must be taken to provide the proper battery voltages before inserting the tube in the receiving set.

The filament is oxide coated and is rated at 0.25 ampere at 1.1 volts or 0.275 watt. Ample emission is obtained from this filament at this rating. The filament should not be heated brightly but instead should be burned at a cherry red heat. An excessive temperature tends to drive the oxide coating from the filament. The tube should be used in a vertical position.

The filament used in this tube cannot be reactivated and any attempt to use the process recommended for other types will only result in immediate burn out of the filament.

Operation as a Detector

The standard detector circuit with grid leak and condenser should be used. The grid is connected to the positive side of the filament when used as a detector. The values of the grid leak resistance and grid condenser capacity are not critical, but a grid leak of 2 megohms and a condenser of .00025 MF is recommended. The normal plate voltage, when used as a detector, is 22.5 volts but 45 volts may be used with slightly increased signal strength. When used in regenerative sets, it will be found that the tube goes into and out of oscillation smoothly so that maximum regeneration may be obtained.

Operation as an Audio Frequency Amplifier

The plate impedance of the C-11 and CX-12 tubes is such that the tube is well suited for audio frequency amplification with standard transformers. When operating telephone head sets or sensitive loud speakers requiring but small amounts of power, the use of a negative grid potential is not absolutely necessary. When greater power output is required, the following negative grid voltage should be used:

Plate	Negative Grid
40-45 V.	0.5 to 1.5 V.
80-90 V.	4.5 V.

The plate voltage should be limited to 100 volts or less and voltages in excess of 67.5 volts should not be used unless the recommended grid bias is added. Without grid bias to limit the flow of plate current, the plate current requirements may be in excess of the available filament emission, resulting in increased plate impedance, distortion and limitation of power output.

The maximum undistorted power output obtainable from C-11 and CX-12 tubes at 90 volts plate and 4.5 volts grid bias is .007 watts.

Operation as Radio Frequency Amplifier

These tubes have been successfully used as radio frequency amplifiers in such receivers as the Radiola Regenoflex, in which the grid to plate capacity is balanced by a special neutralizing circuit. The inter-electrode capacity is moderately high and is, therefore, not especially adapted for radio frequency service. The approximate capacity between electrodes is:

Grid	—	Filament	6 MMF
Grid	—	Plate	5.5 MMF
Plate	—	Filament	7.5 MMF

	Filament Rheostat	Supply Voltage	Rheostat Resistance
1	C-11 or CX-12	1.5	4-10 ohms
2	C-11 or CX-12	1.5	4-10 ohms
3 or 4	C-11 or CX-12	1.5	2- 6 ohms

Types C-299 and CX-299

Cunningham Radio Tubes Types C-299 and CX-299 are general purpose high vacuum tubes especially designed for extreme economy of operation from dry cells. The tubes are identically except for the bases, the C-299 having a special type small bayonet lock base while the CX-299 is mounted on the small standard base. The former type is manufactured principally for replacement purposes since new sets are designed for the standard push type base.

The filament is the thoriated tungsten type requiring 60 milliamperes at 3.3 volts and can be operated from three No. 6 dry cells in series. In portable sets, where weight and space are factors, smaller dry cells may be used with a resulting higher operating cost. Two lead storage cells or three Edison cells may be used for filament supply with multi-tube sets.

The filament should be operated at constant voltages as any overload causes a rapid loss in emission and shortened life. The use of a filament voltmeter is strongly recommended and will repay its cost many times in increased satisfaction, especially in multitube sets, where one tube, low in emission, may result in the use of excessive filament voltage. High resistance voltmeters of good accuracy and small size are now available, a convenient model being Weston Model 506. When such equipment is provided, it will be found that the life obtained from the tube is greatly increased.

The life of the tube is usually ended by a decrease in electron emission rather than by burn out of the filament. This is indicated by the necessity of increased filament voltage to obtain satisfactory operation. It is never advisable to turn the filament above maximum of 3.3 volts, the necessity for so doing indicating usually that one or more tubes are low in emission. These tubes should be immediately replaced to avoid overloading and damage to the remaining tubes in the set. The decrease in emission is not gradual during the life of the tube but occurs very quickly at the end of the life of the filament. Even when this has occurred, a short additional life from such tubes may often be obtained by following the reactivation procedure outlined.

If, by accident, excessive filament or plate voltage is applied to the tube, the filament may lose its emission. If the overload has not

been severe or too long sustained, normal emission may be restored by reactivation.

Operation as Detector

For operation of the tube as a detector, the usual circuits may be employed and the return lead from the grid circuit should be connected to the positive side of the filament. Critical adjustments of grid leak and condenser are not required, although 3 megohms and .00025 MF are recommended. Higher grid leak resistance may be used on weak signals with an increase in sensitivity but the tube may then block on strong local signals. Plate voltage of not more than 45 volts is recommended for detector operation.

It is advisable to provide a cushioned socket for the detector tube and when microphonic action is encountered, maintain the filament voltage at the rated value of 3.3 volts or slightly above, as the tendency of the filament to vibrate often becomes pronounced at reduced filament temperatures.

Operation as an Amplifier

When used as an audio frequency amplifier, very satisfactory results are obtained, the plate impedance being low enough to insure satisfactory quality with any of the standard audio transformers. It may also be used with good results in impedance or resistance coupled amplifiers, a voltage amplification of approximately 5.5 per stage being obtained from resistance coupling and 6.5 from impedance coupling. In portable receivers, it may be advisable to operate the audio amplifiers on 45 volts plate to economize on "B" battery consumption and, in this case, if the rheostat is placed in the negative lead, sufficient grid bias can be obtained by using the drop across this rheostat.

The tube is capable of furnishing sufficient power output to operate small loud speakers, the CX-220 power amplifier tube being designed to supplement the C and CX-299 types when larger volume of undistorted power output is required. The CX-220 tube operates on a plate voltage in excess of 90 volts but voltages higher than 90 should not be applied to the C and CX-299 tubes.

The operating conditions outlined on pages 5 and 6 should be carefully followed in using the C or CX-299 tube since the small filament used in this type has not a high overload factor. The tubes should not be operated above 67.5 volts plate without providing the "C" battery voltage recommended, as without proper grid bias even a small decrease in electron emission impairs the operating efficiency. Satisfactory operation will be obtained with a plate voltage of 67.5 volts when a "C" battery is not included, the curves Fig. 3, plate 4,

showing that very little increase in mutual conductance is obtained when the plate voltage is increased above 67.5 volts (at zero grid bias).

Operation as Radio Frequency Amplifier

The low interelectrode capacity of the C and CX-299 tubes, together with high mutual conductance, result in very satisfactory operation in radio frequency amplifier. The approximate interelectrode capacity is as follows:

Grid	—	Filament	3.6 MMF
Grid	—	Plate	3.5 MMF
Plate	—	Filament	4.5 MMF

The low interelectrode capacity found in this type is responsible for the satisfactory results obtained when used in the intermediate stages of a Super-Heterodyne receiver. Very high over-all voltage amplification may be obtained before instability, due to feed back through the tubes or stray coupling, becomes serious. The precautions mentioned above, namely, the use of not more than 67.5 volts on the plate, except when a grid bias is provided, is also important in obtaining satisfactory results and long life from the tube when used as a radio frequency amplifier. It is quite frequently found that a tube near the end of normal life will show a lower value of mutual conductance at 80 volts plate and zero grid than at 40 volts plate and zero grid. This results from insufficient emission limiting the plate current at higher voltages.

General Comments

It is preferable to mount the tube in a vertical position and a cushion or spring mounting should be provided to prevent microphonic noise when the set is struck or jarred. In most cases, it is sufficient to cushion the detector tube alone, a soft rubber mounting being the preferred type. Frequently the advantages obtained from a cushioned socket are lost by the use of stiff wire connections to the sockets. Very flexible wire should be used.

Great care should be taken to prevent the plate voltage from being applied accidentally to filaments. This precaution is particularly important on account of the extremely low filament current used in the 299 tubes. Tubes should be removed from sockets when connections are being changed. For additional protection while changes or adjustments are being made, the protective tube, C-377, may be placed in series with the plate battery. This will limit the current from the battery in case of accident, without affecting the normal operation of the tube.

Filament Rheostat

Number of Tubes	Supply Voltage	Rheostat Resistance
1 C or CX-299	4.5	30
2 C or CX-299	4.5	20
3 or 4 C or CX-299	4.5	10

So called automatic non-adjustable filament controls have not proved satisfactory with this type of tube because of the very low filament current consumption, and result in the tube being subject to overload voltage with fresh dry cells and in the necessity of discarding the cells before they are completely exhausted.

It is advisable to use the rheostat as a switch to open the filament circuit. The maximum resistance is then in circuit for retarding. This is important with dry cell operation since near the end of their normal life the initial voltage of dry cells, after a period of rest, is considerably above the normal voltage during the discharge period.

TYPE CX-301A

CX-301A, the most popular and widely used type in the Cunningham Radio Tube Line, is a high vacuum receiving tube of the general purpose type. The high mutual conductance and low plate impedance of this model are responsible for the very excellent results obtained when used either as radio frequency amplifier, detector or audio frequency amplifier. It is widely used as a loud speaker supply tube of moderate output.

CX1301A is electrically the same as C-301-A, but is mounted on the large CX standard base instead of the old type base. No change whatever in tube characteristics was made when the new base was adopted. Compared to C-301A production of 1923, CX-301A has higher efficiency resulting in improved performance. The improved efficiency results from a twenty percent increase in mutual conductance.

The CX-301A filament is of the thoriated tungsten type, rated at 5 volts, .25 ampere. The emission at rated voltage is well above that ordinarily required in normal operation and when the tube is used for moderate plate voltages, the filament voltage can be lowered to 4.5 or 4.0 volts without impairing the efficiency and the resulting increase in the life of the tube. A 6 volt storage battery of the lead cell type or a 4.8 or 6 volt Edison battery affords the most convenient source of filament current, except with one or two tube sets where dry cells may be used.

The low filament current required by the CX-301A tubes makes it possible to operate five tubes or more from a single rheostat of 2 ohms resistance. This rheostat may be used as a master control to reduce the filament terminal voltage of all tubes in the set to 5 volts and separate

rheostats can then be used to further reduce the filament voltage on any individual tube, as is often customary for volume control purposes. A circuit diagram using this arrangement is shown in Fig. 4, Plate 25. When a single tube is operated from a separate rheostat, the 10 ohm size is most convenient although for some purposes a rheostat resistance up to 25 ohms may be desirable. In operating a larger number of tubes from the same rheostat, proportionately lower values should be chosen.

With the thoriated tungsten filament, the life of the tube is usually ended by a rapid decrease in electron emission, rather than by actual burnout of the filament.

The exceptional operating efficiency of CX-301A is attained by taking precautions to attain and insure an unusually high vacuum, as even a slight trace of gas impairs the filament emission. Several chemicals which ordinarily give the bulb a uniform "silver" color are introduced in our patented manufacturing processes to obtain this nearly perfect vacuum. This appearance of the bulb is not an indication of the merits of the tube and cannot be taken as a guide in selecting tubes. The presence of a "rainbow" marking, which sometimes has the appearance of a burned spot, is characteristic of many CX-301A tubes. This spot is produced in the factory processes and is not an indication that the tube has been used, reactivated, overloaded or has any special features.

While the materials used in the bulb insure the maintenance of a high vacuum throughout the life of the tube at rated voltages, under some conditions of overload or abuse, slight impairment of the vacuum may result and cause a decrease in electron emission. This is often the case when the tube is used as a rectifier on heavy load currents or at plate voltages in excess of 135 volts. For rectifier service, CX-313 or 316-B rectifier tube should always be used.

In taking emission readings, it is common practice to connect the grid and plate together applying 50 volts anode voltage. When such readings are taken, this voltage should be applied only for a few seconds and the applied voltage should never exceed 50 volts. The use of higher voltages in at least one commercial test set damages the tube and frequently causes the emission current to drop to a value below passing, even though it is applied for only a few seconds.

Use as a Detector

CX-301A as a detector is quiet in operation and does not require critical adjustment of plate or filament voltage. Any plate voltage between 22.5 and 67.5 volts may be used and, while the filament temperature need not be carefully adjusted, it is usually advisable to turn the detector tube up to rated voltage in order to avoid microphonic action which sometimes occurs when the filament is heated to less than

normal operating temperature. The use of a cushioned socket for the detector is always good practice and especially so at present in view of the tendency to use power amplifier tubes in the output stage. The greater intensity of the sound vibrations from the speaker, with power tubes, subjects the detector to increased vibration and, at times, results in "singing" or "howling." The most satisfactory cushioning material is very soft sponge rubber.

A grid condenser of .00025 MF capacity with a grid leak having resistance of 2 megohms is recommended. Higher grid leak give better signal strength on weak signals but may cause blocking or distortion on strong stations.

Use as Audio Frequency Amplifier

The low output impedance of the CX-301A results in excellent performance in the audio stages especially when using the improved types of audio transformers. It is general practice to use 90 volts plate with a grid voltage of -4.5 volts. However, in all except the last audio stage, lower voltages may be used without noticeably affecting the quality and with a resultant marked saving in "B" battery current. The extent of this saving in "B" battery consumption is shown in the following table:

"B" BATTERY CURRENT AND POWER CONSUMPTION

"B" Battery Voltage Volts	"C" Battery Voltage Volts	Plate Current Milliamperes	"B" Power Consumption Milliwatts
45	-1.5	.9	4
67.5	-3.0	1.5	10
90	-4.5	2.0	18
135	-9.0	2.5	34

The use of the lowest voltage indicated in the above table does not result in decrease in voltage amplification and should be taken advantage of in the construction of portable receivers where the very small "B" batteries used are expensive because of their limited capacity.

The CX-301A tube is satisfactory for use in resistance coupled amplifiers, being relatively free from blocking or "stuttering" trouble sometimes encountered in this type of circuit. The low output impedance is also advantageous since the condensers and coupling resistors need not be as large for reproduction of low pitched audio tones as with high impedance tubes.

USE AS A POWER AMPLIFIER

In using the CX-301A tube as a loud speaker supply tube, best results are obtained with a plate voltage of 135 volts, but this voltage should not be used unless the recommended grid bias of 9 volts is

added. If desired, two CX-301A tubes may be used in parallel on 135 volts, the power equalling that obtained from CX-112 at 135 volts plate. When using a single CX-301A tube at 135 volts plate some improvement in tone quality, with slight sacrifice in power output, may be obtained by decreasing the grid biasing voltage to -7.5 volts.

It should be remembered that as "B" battery terminal voltages drop during the life of the batteries, the power output decreases since the "C" battery voltage remains constant. The remedy is to decrease the bias voltage 1.5 volts for every 12 volts drop in plate battery voltage. If this is done, the "B" batteries may be used until their terminal voltage has dropped to between 30 and 35 volts per 45 volt block, when the poorer ones should be discarded.

It is recommended that either Types CX-112 or CX-371 be used as the power amplifier to feed the loud speaker where increased volume with undistorted tone quality is desired.

USE AS RADIO FREQUENCY AMPLIFIER

CX-301A finds its widest use in radio frequency amplification, and is especially desirable because of its high mutual conductance and high input impedance. Its performance is noticeably superior to many of the competitive so-called "A" tubes. Relative measurements made in our laboratory in a typical one stage neutrodyne or tuned radio frequency receiver gave the following average comparative results:

Cunningham CX-301A	1	2.00	20.0	100%
Competitive Types, Lowest.....	1	.64	6.4	32%
Competitive Types, Highest.....	1	1.30	13.0	65%

Difference in tube performance of the order shown in the above tabulation is evident when listening to distant stations, but will not be noticed in tuning local stations.

Many factors enter into tube quality and performance. Plate current and emission readings indicate merely that a tube is in operable condition and give no indication of the quality of performance. A tube may have entirely satisfactory values of mutual conductance, plate current, plate impedance and amplification constant, and yet have a low input impedance. Tests in our laboratory of such tubes have shown that the low input impedance reduces the voltage amplification in the average radio frequency amplifier to 30% of the normal gain and at the same time the selectivity of the tuned circuit is noticeably impaired. A given signal coming in over a range of 20 kilocycles with a CX-301A could be heard over a range of 50 kilocycles with a tube of low input impedance. The volume must be turned up

equal to that obtained with CX-301A to demonstrate this decrease in selectivity. High tube input impedance can only be obtained by using extreme care, not only in the selection of materials used in the tube, but also, in certain of the delicate manufacturing processes.

In radio frequency amplification it has been common practice to use a "B" voltage of 90 volts without a biasing battery, and while this results in maximum amplification, it is somewhat wasteful of current. A decrease in this voltage to 67.5 or 45 volts or the addition of a "C" battery will result in a large saving of "B" battery current, together with improved tone quality on local programs. Two CX-301A tubes as radio frequency amplifiers require 12 milliamperes plate current with 90 volts "B" voltage, 7.0 milliamperes with 67.5 volts and only 3.4 milliamperes when the voltage is reduced to 45 volts. The use of lower plate voltages will often more than double in service obtained from dry cell "B" batteries, and will also aid in securing quiet, hum free service from "B" eliminators, especially those having limited current output.

The decrease in radio frequency amplification obtained from the tube when the "B" battery voltage is dropped from 90 volts to 67.5 is only moderate, since plate impedance rises only about 1,5000 ohms or from 8,000 to 9,500 ohms. An equivalent saving in "B" battery current may be obtained by using the proper "C" battery voltage. When the full "C" voltage of 4.5 volts is provided, as normally recommended with 90 volts plate, the "B" battery current drops from 6 milliamperes per tube to 2 milliamperes, a saving of 67%. The use of a "C" battery voltage less than the rated value may be preferred. A convenient method, and one which does not introduce coupling between stages, is to obtain the grid bias from the 1 volt drop in the filament circuit. A fixed resistance of 4 ohms may be added in the negative filament lead to each radio amplifier and the grid return lead connected to the battery side of this resistance. When the rated current of .25 ampere is flowing, a negative grid voltage of 1 volt will be obtained from this resistor. The saving in plate current is only 1 milliampere but the input impedance will be greatly increased, resulting in decreased damping of the input circuit. This will increase the receiver selectivity and senestivity, by offsetting the effect of increased plate impedance.

When tuned circuits are used as the coupling between successive radio frequency stages, the tube characteristics play an important part in determining not only the voltage amplification but also the degree of selectivity. Each tuned stage feeds directly into the input of a radio frequency amplifier tube, and a low tube input impedance is equivalent to adding a resistance in parallel with the tuning condenser,

with resultant broadening of the tuning and a decrease in the voltage built up across the condenser by a given induced signal voltage. This effect may be reduced to a minimum by means of the method just explained,—the use of at least a small grid bias. The tube output resistance is coupled into the succeeding tuned stage to an extent determined by the amount of coupling between stages. This has the effect of increasing the resistance or damping of the tuned circuit and accounts, in a large measure, for the general practice of using a fewer number of turns in a coupling coil than the proper number for maximum energy transfer. The output impedance of the CX-301A is maintained at a consistently low value while the input impedance is uniformly high. These two factors account for the uniform success and popularity of CX-301A as a radio frequency amplifier.

SPECIAL ALKALI VAPOR DETECTOR TYPE CX-300A

Cunningham Special Alkali Vapor Detector, Type CX-300A, is specially designed only for service as a detector tube. In sensitivity it fully equals the best obtainable from a CX-200 when critically adjusted, and, through the use of a new principal in tube design, CX-300A attains this sensitivity without critical adjustment either of filament or plate voltage. The filament rating is identical to the CX-301A, 5 volts, .25 ampere.

Special precautions have been taken in the design of the tube to eliminate all microphonics and the tube is superior to the CX-301A in this respect. It is interchangeable with C or CX-300 and C or CX-301A in the detector socket, no change in wiring or circuit design being necessary, although some slight improvement will be noticed if the grid return is changed and connected to the negative filament, as shown in the diagram Fig. 3, Plate 10.

When receiving a powerful local station, no appreciable improvement in volume will be noticed when Type CX-300A is substituted for either CX-300 or CX-301A. The same set, however, on distance reception will show a marked improvement in signal intensity and in the clarity of reproduction due to the greater response obtained from the CX-300A on weak signals. A signal which is inaudible on the CX-301A may be brought in with good volume on the CX-300A, the increased audibility closely approximating that obtainable from an extra stage of radio frequency amplification.

The use of the CX-300A will not directly improve the selectivity of a receiving set in which it is used but makes possible slight modifications in design resulting in an improvement in this respect. For instance, without sacrifice in volume, the antenna may be more loosely

coupled to the receiving set when a CX-300A is used as the detector. This will, to a large extent, diminish the amount of interference being picked up from local stations. Also a shorter antenna may be used without loss in audibility and some gain in selectivity.

The supersensitive detector action has been obtained without excessive tube noise which has always been a limiting factor in such tube types. A slight hiss is noticed when the tube is first lighted. This slight hiss is not objectionable and will continue only for a few minutes or until the tube has warmed up.

The usual detector plate voltage of 45 volts is recommended for this type but any voltage down to 22.5 volts may be used. The plate impedance becomes rather high at low plate voltage and, as a result, best quality of reproduction will be obtained when the recommended voltage of 45 is used. The tube has been designed with an amplification constant of about 20, while the plate impedance averages only 30,000 ohms.

Used in Regenerative Receivers

The CX-300A is unusually well adapted for service in regenerative receivers. The usual values of tickler or other feed-backs are satisfactory. The tubes goes into and comes out of oscillation very smoothly. These operating characteristics allow maximum regeneration to be obtained without the tendency to spill over sometimes noticed in connection with the use of the CX-301A as a detector.

The combination of high detector sensitivity and smooth regenerative action makes this tube ideal for service in short wave receivers where radio frequency amplification is less effective. Amateurs will find that the substitution of this tube will greatly increase their receiving range and the reliability of operation. In this service the plate impedance may be raised by dropping the plate voltage to 22.5 when the tube is being used in connection with sharply peaked audio transformers. This resultant increase in plate impedance helps to cut off the lower frequencies, a desirable characteristic in this particular service.

Grid Condenser and Grid Leak

The usual sizes of grid condenser and grid leak are satisfactory, average values being .00025 MF condenser and 2 megohm grid leak. The preferred connection for the grid return is to the negative filament.

Rheostat Control .

A filament rheostat having resistance of at least 10 ohms is best suited for the control of this tube when it is operated from a separate rheostat. It may be operated in parallel with other CX-301A tubes in the set without change in the rheostat size.

TYPE CX-300

The CX-300 is a special gas content detector designed only for detector service. It is real sensitive when plate and filament voltages are carefully adjusted to the best operating point, generally found between 16.5 and 22.5 volts plate and 4.25 to 5.0 volts filament.

The filament rating is 5.0 volts, 1.0 ampere, and a separate control rheostat should be provided having a resistance of from 2 to 6 ohms. The bulb is clear, and the tungsten filament burns at a white heat, showing up much more brightly than does the CX-301A tube. The heavy filament and rugged construction insure freedom from microphonic noise or "howling," and a cushioned socket is less necessary with this type than with others.

A potentiometer across the filament terminals should be provided to secure fine adjustment of the plate voltage, the —"B" return being connected to the slider. This connection, together with a tapped 22.5 volt "B" battery, allows adjustment of the "B" battery voltage between 16.5 volts and 28.5 volts in very small steps.

The CX-300 operates to best advantage when the grid return is connected to the negative filament terminal, the ionized gas in the tube causing sufficient grid current to flow to obtain detection with the conventional size of grid condenser and grid leak. Values of grid leak resistance between 1.0 and 2.0 megohms and a grid condenser of .00025 MF are recommended.

It is expected that the CX-300A will rapidly supercede the CX-300, the former tube having equal or superior sensitivity without the necessity for careful voltage adjustments.

Author's Note:—

In connection with audio amplifiers having three or four audio frequency stages the CX-200 detector has been found considerably superior. The main advantage is entire freedom from microphonic noises. The increased sensitivity of the CX-200 over all other detectors is considerably magnified in a four stage amplifier and the superiority instantly recognized. Maximum results are not obtainable with the CX-200 unless the operator carefully adjusts the plate and filament voltages to the best value, suited for each particular tube used and this can only be found by experiment, noting best reception on weak signals.

POWER AMPLIFIER—TYPE CX-220

Cunningham Radio Tube Type CX-220 is a high vacuum tube designed for dry battery operation as a power amplifier to supplement the C and CX-299 tubes. It must be used only in the last audio stage to supply the loud speaker and its output has been determined as the maximum consistent with dry battery operation. The undistorted output is greater than that of 2—CX-299 in parallel or in push-pull combination and about double the undistorted output of CX-301A. When substituted for C or CX-299 in the last stage the quality of reproduction is very

noticeably improved, the improvement being especially marked when operating any of the low impedance types of speakers.

As explained below, the characteristics of this tube require a high voltage input and, without distortion, CX-220 will handle approximately four times the voltage input which can be supplied to the C or CX-299 tubes. For very low values of input voltage slightly less volume will be obtained from the CX-220 than is given by the C or CX-299.

A low value of amplification constant has been chosen in the design of this tube. As a rheostat of high negative grid biasing (or C) battery voltage is required. This results in the marked advantage under ordinary operating conditions, that the grid will not become positive, and, distortion due to the flow of grid current is therefore avoided. A low output impedance, together with the high grid bias, results in musical reproduction of unusual tone range and volume.

The filament, of the thoriated tungsten type, designed to operate in parallel with the CX-299, requires 125 milliamperes at 3.3 volts.

Maximum power output is obtained from the CX-220 tube when a plate voltage of 135 volts is provided. This may be supplied by any combination of dry cell "B" batteries such as six 22.5 volt batteries or three 45 volt batteries connected in series, or from any of the "B" battery eliminators provided with a 135 volt tap. The operating design permits the plate voltage to drop to 120 volts, or slightly below, before the output is materially decreased.

As noted, an unusually high value of grid biasing voltage is required and satisfactory results cannot be obtained from the tube unless this voltage is supplied. As there is no current drain on the battery, the small size "B" battery which is made in 22½ volt blocks, will be found convenient. The only requirement is that the battery must have a satisfactory shelf life, that is it must not run down too rapidly under open circuit conditions. A convenient type is the Eveready 766, or equivalent. If the tube is used for any considerable period of time without grid bias, life will be shortened due to the flow of excessive plate current. The grid return should be connected to the negative terminal of the 22.5 volt bias battery, the positive terminal of this battery being connected to the negative filament terminal. If a tapped battery of the type described above is used, the terminal marked "+18 volts" may be used to provide the 4.5 volt bias required by the remaining tubes in the set. The +18 volt terminal when measured from the positive 22.5 volt end of the battery is, of course, the -4.5 volt tap. The grid biasing batteries should be replaced when on test the terminal voltage has fallen to 17 volts, or when noisy operation or distorted music is noticed.

An adapter is required for use in C-299 type sockets and several convenient types are available which also allow the additional grid and plate batteries to be added without change in the wiring of the set.

POWER AMPLIFIER—CX-112

CX-112 is a special loud speaker supply tube or power amplifier for use in last audio stage only. The filament is rated 5.0 volts terminal, 0.5 amperes, and is of the oxide coated type and glows at a dull temperature scarcely visible in daylight. It is important not to exceed 5.0 volts at the tube terminals as the life will be shortened if the tube is overloaded. The filament cannot be reactivated and an attempt to use the process recommended for CX-301A tubes will result in an immediate burn-out. The tube may be operated in parallel from the same rheostat provided for the CX-301A tubes in the set.

This tube may be operated at plate voltages between 90 and 135 volts with proper grid bias. At 90 volts it may be used to replace CX-301A in the last stage if the set is provided with 4.5 volt grid bias. This substitution will result in slightly improved audibility and greatly improve tone quality.

Best results from CX-112 are obtained at the maximum plate voltage of 135 and in sets not designed for this tube the necessary grid and plate potentials can be supplied through the use of a socket adapter or by relatively simple wiring changes in most sets.

POWER AMPLIFIER TYPE CX-371

Cunningham Radio Tube Type CX-371 is a power amplifier tube designed to supply a large volume of undistorted power for loud speaker operation. The design is such as to permit these results to be attained with moderate plate potentials, 90 to 180 volts. The use of this tube practically eliminates the possibility of tube distortion, and pure, natural reproduction—as perfect reproduction as the speaker design and transformer characteristics permit—is the result.

The CX-371 will be most widely used in conjunction with CX-301-A tubes, since it is suited for use in the last audio stage only. At least one audio stage must be used ahead of the CX-371, as the tube requires a high input signal voltage, and if an attempt is made to operate directly from the detector tube into the CX-371, overloading of the detector will occur long before the CX-371 is producing full volume. The CX-371 will not operate satisfactorily as a detector or voltage amplifier.

SPECIAL REQUIREMENTS

Before the CX-371 can be used in receiving sets not designed for it, the proper grid biasing voltage must be provided. Considerable power output, ample for ordinary home use, is obtained on "B" battery voltages of 90 volts. When this voltage is used the "B" battery voltage must be

kept up close to 90 volts or the power output will be greatly limited. As the "B" battery voltage drops, one or more Eveready 771, or equivalent, may be added in series to obtain additional service from the "B" battery. For dancing or when insensitive reproducers are used, higher voltages are needed.

When used on plate voltages in excess of 90 volts, an output transformer having a 1:1 ratio, and of low primary resistance should be provided. The General Radio Type 367 is well suited for this service, or a combination of low resistance choke and by pass condenser may be used (page 292). The reason for providing the transformer or choke is that the heavy D. C. plate current must be kept out of the speaker windings, as it is in excess of the value which can be safely carried by the coils, and also to avoid the very appreciable drop in "B" battery voltage which is caused by the fairly high resistance of the average speaker windings. A speaker having a resistance of 1500 ohms will cause a drop of 15 volts on 10 M. A. plate current, or 30 volts with 20 M. A. This value of resistance is about the average with present speaker design. In view of the relatively high cost of "B" battery current, precautions to prevent this loss in voltage are quite worth while.

FILAMENT

The same rugged thoriated tungsten filament used in the CX-301A is provided in the CX-371, except that the current required is .5 ampere, or double that taken by the CX-301A. The terminal voltage is the same, 5.0 volts, and the tube may be operated in parallel with CX-301A tubes from the same rheostat. When operated on a separate rheostat, a resistance of 3 to 6 ohms is necessary, or a fixed resistance of 2 ohms will be found satisfactory when a 6-volt storage battery is the source of filament current. The filament may be reactivated by following the same treatment used with the CX-301A tubes.

OPERATING VOLTAGES

The recommended grid voltages for operation at various plate voltages is indicated in the tabulation below. A variation of several volts is permissible in the higher grid bias voltages and, if convenient, longer life may be obtained from dry cell "B" batteries if the grid bias is decreased as the batteries become old and their terminal voltage drops.

Plate Voltage	Negative Grid Voltage	Maximum A. C. Input Voltage (RMS)	Approximate Plate Current Milliampères	Resultant Undistorted Power Output (Max.) Watts
90	16.5	11.6	11	.13
135*	27.0	19	16	.35
157.5*	33	23	18	.50
180*	40.5	38	20	.65

*At these plate voltages use the output circuit shown in plate 19.

RATING

Filament Voltage.....	5.0 volts
Filament Current.....	.5 amperes
Amplification Constant.....	3
Plate Impedance (180,-40).....	2000 ohms

The C-X371 has been designed especially to meet the requirements of the best possible design for power amplification. See section on power output. The amplification constant has been kept low, with resultant low plate impedance.

As explained in that section, the plate impedance is such that a load resistance (or impedance) of 2500 ohms or above is the only requirement for ample undistorted power output. This means that any of the speakers now available may be operated without any "impedance adjusting" transformer or means other than that provided to keep the D. C. component of the plate current out of the speaker windings.

RECOMMENDATIONS BETWEEN CX-112 AND CX-371

The CX-371 is to be preferred to the CX-112 in installations where the grid and plate voltages desired can be conveniently added. The CX-371 cannot be used in sets where the tubes in the first and second audio stages must be operated from the same grid and plate voltages, since the high grid bias required for the CX-371 will block a tube having characteristics similar to the CX-301A. It should be remembered that the CX-371 gives less voltage amplification than CX-112 tubes and a higher input voltage must be supplied. This difference may best be shown by the following comparison: If several transformers having equally satisfactory characteristics but with different ratios are available, the CX-371, with a 6:1 ratio, will give the same output voltage as is furnished by the CX-112 with a 2:1 transformer. In such cases, however, the actual reproduction from the CX-371 will be louder because of the lower plate impedance.

**POWER AMPLIFIER—OSCILLATOR
TYPE CX-310**

Superseding the C-302 power tube, the CX-310 tube incorporates many important improvements including increased mutual conductance due to the use of the thoriated tungsten filament, larger plate area with a corresponding increase in maximum safe plate dissipation and in power output, increased filament emission and decreased inter-electrode capacity. The plate is now very rigidly supported from a stem collar and the plate lead brought out through a separate seal, this construction also allowing the grid and filament leads to be more widely separated in the stem seal.

For broadcast reception, the CX-310 is of especial interest where maximum undistorted power output is required for the operation of large loud speakers. Because of the low output impedance, the quality of reproduction obtainable is exceptionally fine. The high plate voltage required is conveniently supplied from a rectifier using one or two CX-316B rectifiers, or a single CX-313 when full output is not required. In either case, freedom from tube distortion is assured on all outputs from a mere whisper up to the full volume which can be carried by the largest cone type speakers. Operation on plate voltages below 180 volts is not recommended, the CX-371 being preferable in such cases.

The CX-310 is a very efficient transmitter because of its high mutual conductance, and its popularity as an amateur transmitting tube is rapidly increasing. In short wave work the very low inter-electrode is of importance and it is of interest to note that with the special construction adopted for the CX-310 tube, it has been possible to obtain a grid to plate capacity which is actually lower than that found in the CX-301A, averaging 8 MMF. The plate to filament capacity is also correspondingly low resulting in an improvement in power output obtainable on wave lengths below 20 meters.

When voltages on the order of 350 to 425 volts are used on the plate of the CX-310, great care should be taken in providing ample insulation and in preventing the high voltage leads from being exposed. All parts of the circuit should be handled and adjusted with care as a dangerous shock to the operator may otherwise result. Care should be taken to turn off the current at the source before making adjustments to the circuit.

	Amplifier in Receiving Circuits	Oscillator	Modulator or Power Amplifier
Filament volts*.....	7.5	7.5	7.5
Filament amperes.....	1.25	1.25	1.25
Plate volts.....	180-425	350	350
Plate current (Aver.).....	7-24 M. A. 60 M. A. (oscillating)		
Maximum Safe Plate			
Power Dissipation....	12 watts	15 watts	15 watts
Grid Bias.....	10-35 volts		25 volts

*Operation from A. C. filament source is preferable.

CX-310 is designed for use as the power amplifier in Radiola Loud Speaker Model 104 and similar devices.

OUTPUT VOLTAGE REGULATOR OR GLOWTUBE TYPE CX-374

Cunningham Radio Tube Type CX-374 is a splendid "glow" type voltage regulator tube designed for service in "B" battery eliminators

where great flexibility in output current is required or where the A. C. line voltage varies over rather wide limits. It is particularly valuable in eliminators where various voltage taps are required. When CX-112 or CX-371 is used in conjunction with CX-301-A, the eliminator must supply from 120 to 180 volts with a maximum current drain of 20 milliamperes, together with a 90-volt tap supplying a maximum of 20 milliamperes and a detector tap for 45 volts with a maximum requirement of approximately 3 milliamperes. The use of variable high resistance units to obtain these voltages is not entirely satisfactory. The resistance units often become noisy or burn out and are not effective until current is established in them, with the result that as the receiving set is turned on the voltage across the "B" terminals may rise to very high values.

The CX-374 tube accomplishes voltage regulation from its characteristic that on any current flow from 10 to 50 milliamperes the tube develops a voltage of 90 volts, plus or minus 10%. This tube cannot be used without a ballasting resistance to limit the maximum current to 50 milliamperes, this flow normally occurring when the receiving set is turned off and the "B" eliminator left running. The application of the tube to the ordinary type of "B" eliminator can be understood by reference to the diagram, Fig. 1, Plate 23, where the glow tube, Type CX-374, is shown as it would be used to regulate the voltage supplied to the 90-volt "B" tap on the receiving set. The exact current and voltage which may be taken from the high voltage tap provided for the power amplifier tube may be easily varied to suit any particular condition by the proper choice of the resistance R. For ordinary work, 135 volts and 10 milliamperes will be found satisfactory for this service. 20 milliamperes at 180 volts can be obtained by proper choice of the resistance R.

In operation the tube glows with a beautiful pink color which surrounds the cathode. If the tube connections are reversed a pronounced blue glow will occur at the anode terminal, and the connections should be corrected. Proper results will not be obtained unless connections are made as indicated in the diagram. The terminals which would normally be + "F" and plate are connected together in the base of the tube and this short circuited connection may be used as a line switch in the transformer primary. With this connection, the eliminator cannot be turned on until the CX-374 tube is inserted in the socket nor can the tubes be interchanged in such a way as to damage either the equipment or tubes themselves. If a rectifier or power tube is inserted in the socket intended for the CX-374, the transformer primary will remain open and no power will flow to the equipment.

LINE VOLTAGE OR BALLAST TUBE TYPE C-375

C-376 is a "ballast" tube designed to regulate the input voltage across the primary of the transformers used in "B" battery eliminators. The tube will pass 1.7 amperes at any applied voltage between 40 and 60 volts and the load on the transformer secondary must be so adjusted as to bring the voltage on the tube to 50 volts at the normal line voltage. If the line voltage averages 115 volts, the transformer, under load, should be designed to take 1.7 amperes at 65 volts, the remaining 50 volts being dropped in the ballast tube. If the line voltage, for any reason, drops or rises 10 volts, the voltage across the ballast tube will change accordingly and the transformer primary voltage will remain constant at 65 volts. The tube requires several minutes to heat up, the voltage drop increasing rapidly for the first three minutes and then slowly up to about ten minutes by which time the tube has reached its final temperature. Thereafter it will maintain the voltage practically constant as long as the device is in operation.

C-376 will regulate the primary transformer voltage on frequencies from 25 cycles to 60 cycles provided the transformer has been designed for the operating frequency and under load fulfills the above conditions.

C-376 should be protected by a metal housing properly ventilated. Its use is limited to equipments designed for definite operating conditions.

C-376 is designed in Radiola Loud Speaker Model 104 and similar devices.

POWER OUTPUT AND CHARACTERISTICS OF LOUD SPEAKER SUPPLY TUBES

One of the most interesting phases of vacuum tube operation is the study of the conditions under which maximum undistorted power output can be obtained. By assuming special operating conditions, it is possible to so simplify the problem as to eliminate all but the most simple mathematical computations. We are indebted to the Research Laboratory of the General Electric Company for an outline of the method here presented, the data and curves having been compiled in our own laboratory.

The ordinary output circuit is shown in Fig. 1, Plate 18. To simplify the method, it is convenient to replace the speaker load with a non-inductive resistance as shown in Fig. 2, Plate 18, and assume a source of constant input voltage. The power output obtained from a tube under these conditions can be very readily measured and the results of actual measurement compared with the results obtained by computing the output.

CALCULATION OF POWER OUTPUT, OPTIMUM LOAD RESISTANCE AND DISTORTION

In the operation of tubes as first stage audio amplifiers on low input voltages, operation is confined to a small section of the characteristic curve which is relatively straight and, for that reason, the amount of distortion introduced is negligible. If the tube is operated as an oscillator, the question of distortion is not important and the tube may be allowed to operate over the full range of the plate current-grid voltage characteristic curve. When operating as a power amplifier, the problem is to obtain maximum power output without distortion and this means confining the operation to that portion of the characteristic which is practically straight. This definitely limits the power output, for example the CX-310 tube, which is capable of giving perhaps 20 watts as an oscillator, will supply only 1.5 watts of undistorted power output as an amplifier when operating at 425 volts.

The CX-371 tube has been chosen to illustrate the simplest method of computing the power output, the operating voltage chosen being the highest plate voltage recommended for this type, 180 volts. The first step is to measure the plate current at various values of plate voltage up to 120 volts, with zero grid bias (grid returned to negative filament terminal). This is plotted in Plate 17. Since the amplification constant of this tube is 3, the equivalent curve for a grid voltage of -10 volts is a similar parallel curve 30 volts along the axis and running parallel to curve just taken. Therefore, readings for the first curve only need be taken and additional curves can be plotted by extending them parallel to Curve 1, at a distance corresponding to the product of the amplification constant and the applied grid bias voltage. These curves should be plotted to a value of grid bias at least twice that chosen as the operating bias,—in this case, twice 40.5, or 81 volts. Next determine the minimum value of plate current which can be allowed to flow. The exact minimum will depend on the curvature of the tube characteristic, and for the various types of power amplifier tubes used for loud speaker supply work, 1.0 milliampere is a convenient value. If lower values are chosen, distortion will be introduced. A horizontal line is drawn thru the value of plate current chosen as the minimum.

The plate voltage which is to be used has already been fixed at 180 volts and the grid bias at the recommended value of 40.5 volts. Next determine the tube impedance at the operating point, this point being the intersection of the -40.5 volt line with the 180 volt plate ordinate, Point A in the figure. The slope of a tangent to the -40.5 volt line is a measure of the tube impedance and this value may be determined as follows: (The line actually used, GH, has been drawn, merely for con-

venience, as a tangent to the -40.5 volt line, the points G and H being chosen at any point along this line). The co-ordinates of these points are:

Point G; $E(1)$ equals 216.5 volts; $I(1)$ equals .038 ampere.

Point H; $E(2)$ equals 158.5 volts; $I(2)$ equals .008 ampere.

From these readings, the plate impedance $R(p)$ is computed.

$R(p)$ equals $E(1)$ minus $E(2)$ divided by $I(1)$ minus $I(2)$ equals 1950 ohms. A simple rule for selecting the best load impedance has been given by Mr. W. J. Brown, (Proc. Lon. Phy. Soc. Vol. 36, Pt. 3, Apr. 1924), this being that maximum power is delivered by a tube when the load impedance is made equal to twice the tube impedance. As different computations are worked out in connection with the various tube types, it will be found that this rule holds true, but the detailed proof will not be given here. This is an important consideration and is at variance with the general idea that the impedance of the load in the output circuit of the tube should equal the tube plate impedance, the latter conclusion being reached by regarding the tube merely as an electrical generator and disregarding consideration of the distortion introduced by the tube. With the CX-371 chosen for the illustration, the load impedance for maximum power output is, therefore, 2×1950 or 3900 ohms. To determine the actual amount of power which will be delivered into this load it is necessary to draw thru the Point A a line having a slope equal to the reciprocal of this load resistance. This line has been plotted as the line BC. The proper slope for this line may be readily determined as follows: The Point A is at the 1801-volt line; dropping to 140 volts involves a 40-volt change (Point Y). 40 volts applied to a load resistance of 3900 ohms will cause a current change I equal to E divided by R equals 40 divided by 3900 equals .0102 amp. The point A is at 18.5 milliamperes or .0185 amp. Therefore, to plot the reciprocal of the load resistance line, the line should pass thru the point on the 140-volt line equal to the sum of these two currents, the Point X at 28.7 m. a.

The line BC intersects the $I(\text{min.})$ voltage line at a grid bias of -80 volts and is, therefore, extended an equal distance above the Point A or to the -1.0 volt line. The length of this line is proportionate to the power output of the tube and may be scaled off as follows: Determine the co-ordinates of the Points B and C in terms of volts and amperes. These values represent the peak swing of the output current and voltage. Assuming that the input voltage is a sine wave, the effective values of current and voltage are .7 of the maximum values or are equal to the maximum values divided by the square root of two. The power output is equal to the product of the effective values of current and voltage and, since the values scaled off the chart represent the sum of

the positive and negative peak values, both the voltage and current must be divided by 2 to obtain the peak value of the swing in one direction and again by the square root of 2 to reduce to the effective values. These considerations are represented by the following equation:

$$(1) P \text{ equals } \frac{1}{2} \text{ times } E \text{ (max) minus } E \text{ (min) divided by square root of } 2 \text{ times } \frac{1}{2} \text{ times } I \text{ (max) minus } I \text{ (min) divided by square root of } 2 \text{ equals } \frac{1}{2} \text{ times } \frac{1}{2} \text{ times one over square root of two times one over square root of two times } E \text{ (max) minus } E \text{ (min) times } I \text{ (max) minus } I \text{ (min) equals one-eighth times } E \text{ (max) minus } E \text{ (min) times } I \text{ (max) minus } I \text{ (min)}.$$

Referring again to the figure the co-ordinates of Points B and C are:

Point B, E (max) 250 volts; I (min) 1.0 m. a. or .001 amp.

Point C, E (min) 96 volts; I (max) 40 m. a. or .040 amp.

Substituting these values in equation (1) we determine the power output:

$$P \text{ equals one-eighth times } 250 \text{ minus } 96 \text{ times } .04 \text{ minus } .001 \text{ equals } .75 \text{ watts.}$$

This value is higher than that shown as the rated maximum power output obtainable from the CX-371, only because the particular tube used in plotting the curves had a plate impedance lower than the average value for the CX-371 type.

Several interesting conclusions may be derived immediately from a study of Plate 17. The first is the question of the amount of distortion introduced by the tube under the given conditions. This may be quickly determined by scaling off the peak voltage values in each direction along the load line from the Point A. The line AB represents an upward swing of 250 minus 80 or 70 volts, while AC is 180 minus 96 or 84 volts. The average peak value of the voltage output by the tube is one-half 70 plus 84 or 77 volts, and the difference in peaks is due almost entirely to a second harmonic component which has been introduced by the curvature of the grid voltage-plate current characteristic. The peak value of the second harmonic voltage is 84 minus 77 or 7 volts, and the distortion therefore 7 divided by 77 times 100 or 9.1%. Reducing these values to effective sine wave values (R. M. S. values), we have:

Output Voltage (Fundamental) E equals 77 divided by square root of 2 or 54.5 volts.

Output Voltage (Harmonic) E equals 7 divided by square root of 2 or 4.95 volts.

This distortion, 9% seems rather large, but it is scarcely discernible to the ear on a listening test. It is important to remember that this distortion occurs only when maximum power output is being obtained,

which in practice is only momentarily when a loud passage in the music or speech from a broadcasting station is reached. It may be reduced to any desired value in any one of several ways, any one of which involves a small sacrifice in output power:

(1) By reducing the input signal voltage.

(2) By using a higher load impedance.

(3) By reducing slightly the grid bias voltage, at the same time reducing the input voltage.

In general, a distribution of 5% is entirely negligible, and up to 10% scarcely noticeable.

It will be noticed that in Plate 17 the input voltage is not quite sufficient to drive the grid to zero voltage on the positive swing, the value reached being -1.0 volt. This is due to the fact that two fixed conditions were assumed at the start, the plate voltage and the grid bias. As a matter of fact, the grid bias for maximum power output for this particular tube should have been slightly lower than the average value used, 40.5 volts. With this correction, the power output would be slightly larger.

By plotting in various load lines corresponding to loads from 1,000 to 20,000 ohms on this same figure, the amount of power which the tube can deliver to various loads can be determined. This has been done, and the results plotted in the form of a curve, Fig. 3, Plate 18. These results have been plotted to a logarithmic scale in order to more closely approximate the actual effect on the ear of a listener under operating conditions. It will be seen that maximum power is delivered to a load of 3,850 ohms, this slight change from the assumed value of 3900 ohms being due entirely to the fact mentioned above, namely, that the grid bias was not readjusted to a slightly lower value. The amount of power delivered to loads having lower resistance decreases rapidly as the load drops, but only slowly when the load is increased above the best value.

Since the impedance of speakers used in reproduction of broadcasting varies with the frequency, being in general low at low frequencies and increasing with frequencies up to moderately high frequencies, it is important to consider the speaker impedance at the lowest frequency which it is desired to reproduce. From Fig. 3, Plate 18, it is evident that if the load resistance drops much below the tube impedance of 1950 ohms, the amount of power available is very much decreased, and, furthermore, unless the input voltage is reduced, the amount of distortion is greatly increased. Thus power output on all frequencies must be sacrificed unless the load impedance is maintained at a suitable value. As the limitations are much less marked at high load values, a good rule to follow is to keep the load impedance above a

value equal to the tube impedance at the lowest frequency which is to be reproduced.

MEASUREMENT OF POWER OUTPUT

The computations of power output may be checked very readily by setting up the equivalent circuit, Fig. 2, Plate 18. This was done to check the calculations obtained from Plate 17.

Load Resistance, R(1)..... 3900 ohms

Plate Voltage..... 180 volts

Plate Current..... 18.3 m. a.

"B" Voltage*..... 180 plus $3900 \times .0183$ or 251.3 volts

*(Raised to compensate for drop in Load Resistance).

Applied A. C. Voltage—39.5 volts (peak). 28.0 volts R. M. S.

Load Current (A. C.) I—.0136 m. a.

Power Output equals I squared times R(1) equals .72 watts.

This is in close agreement with the computed value, .75 watts.

It is interesting to note in connection with the computation of power output from the curves that with low impedance loads, e. g. low frequency tones, the grid voltage negative swing is limited by I (min). The positive grid swing is not limited, however. The result is that the mean D. C. plate current is increased (Point A raised) when excessive signal voltage is applied to the grid. This type of distortion can be checked with a milliammeter in the plate circuit of the power output tube. Increasing the plate voltage would help to eliminate this distortion.

TYPE CX-299

Fig. 1, Plate 5, shows the curves for computing the power output from the C and CX-299 tubes. With a high impedance load, somewhat greater undistorted output can be obtained from these tubes at 90 volts plate by increasing the bias to 7.15 volts. In the curves shown, the power output, with 90 volts on the plate and a bias of -4.5 volts and a load impedance of 15,000 ohms, is .0075 watts. Increasing the bias to -7.15 volts and the load impedance to 36,000 ohms resulted in an output of .0175 watts. Note that this only gives greater undistorted power output when the input voltage to the grid is correspondingly increased.

Watts output plotted against load resistance is shown in Fig. 2, Plate 5, for a plate voltage of 90 and a bias of 4.5 volts.

TYPE CX-220

The curves for computation of power output from the CX-220 are shown in Fig. 1., Plate 8. With a load impedance equal to twice the tube impedance (2 times 6500 or 13,000 ohms), the power output is considerably increased. In the curves shown, the bias was adjusted to an optimum resulting in a slight increase in output, and decreasing distortion.

The curve Fig. 2, Plate 8, shows how the plate circuit load resistance flattens out the grid voltage-plate current characteristic and thus decreases the tendency for distortion due to curvature of the characteristic.

Plate 9 shows the A. C. characteristics of the CX-220 plotted against the A. C. voltage to the grid.

TYPE CX-112

The curves for computing power output are shown in Plate 14, and load lines are shown for loads of 4900 ohms and 9800 ohms. The slight increase in bias at the higher impedance results in slightly greater power output and decreases distortion. The curve Fig. 2, Plate 14, shows that for a plate voltage of 135 volts and a grid bias of 9 volts, the power output for the CX-112 tube is an optimum at approximately 9000 ohms or about twice the tube impedance.

TYPE CX-301A

Curves for undistorted power output of the Typt CX-301-A are shown in Fig. 3, Plate 12. Load lines for maximum undistorted power output at plate voltages of 90 and 135 are shown.

TYPE CX-371

The computation of the output characteristics of the CX-371 are shown in the preceding discussion. Load lines for maximum output at plate voltages of 90 volts and 135 volts are shown on Plate No. 16, Fig. 3. With the high value of grid bias required on this tube, possibility of distortion due to excessive signal input voltage is greatly lessened.

Sufficient undistorted power output for satisfactory loud speaker operation may be readily obtained from this tube with 90 volts "B" battery voltage.

SUMMARY

From the preceding discussion it will be seen that the load impedance (generally the load consists of a loud speaker) may have quite an appreciable effect upon the quality of reproduction obtained. Careful design and selection of the loud speaker is necessary if good quality reproduction is to be obtained.

FULL WAVE RECTIFIER TYPE CX-313

HALF TYPE RECTIFIER TYPE CX-316B

Type CX-313 is a Full Wave Rectifier, its internal construction consisting of two plates or anodes. It may be used as a single wave rectifier by connecting the two plates in parallel, in which case the filament voltage must be reduced in amount sufficient to hold the load

current to less than 65 milliamperes. The maximum D. C. load current is 65 milliamperes, and the maximum A. C. voltage is 220 volts (R. N. S.) per anode.

Type CX-316B is a single anode tube for half wave rectification, but two may be used to accomplish full wave rectification. The maximum D. C. load current is 65 milliamperes with a maximum A. C. voltage of 550 volts (R. N. S.). When two CX-316B tubes are used in a full wave circuit the maximum D. C. load current is 130 milliamperes.

There are four general methods of accomplishing rectification of alternating currents, namely, by means of a thermocouple, chemical rectification, ironized gas or the unilateral conductivity of a heated filament in vacuum. Cunningham types CX-313 and CX-316B are the filament type, and this construction possesses the maximum in desirable features and none of the disadvantages naturally inherent in the other methods of rectification.

A satisfactory battery eliminator must deliver constant and uniform voltage under varying load condition. The most important factor in obtaining satisfactory load regulation is low internal resistance in the rectifying device, and the filament type rectifier excels in this respect. High internal resistance causes the output voltage to vary rapidly with even small changes in load current. Low internal resistance lowers the requisite transformer secondary voltage, resulting in increased safety and ready compliance with Underwriters' specification. CX-313 has internal resistance of less than 2000 ohms under full load current of 65 milliamperes. A transformer supplying a secondary terminal voltage of 200 volts R.M.S. will furnish a DC output of approximately 50 milliamperes at 135 volts, and higher output voltages are available with a lower load current. From the standpoint of load regulation the filament type rectifier is unexcelled.

In order to obtain a smooth DC output circuits are required, and the requirements of these circuits are minimized by the use of filament type rectifiers. There is no arcing or sparking when using type CX-313 or type CX-316B, and hence no tendency to set up radio frequency surges or impulses which may be difficult to filter.

It is impossible for reversed current to flow in the filament type rectifying device and also reduces the output and increases the ripple voltage.

The filament used in Cunningham rectifier tubes is of thoriated tungsten, and ample latitude for line voltage variation has been allowed in the design. CX-313 is rated at 5-volts filament terminal voltage, with an allowable variation of plus or minus 10%. This is adequate to take care of the normal voltage variation met with in practice,

since the line voltage commonly encountered varies only between 105 and 124 volts, and the nominal value is 115 volts.

Circuit Design: A rectifier circuit suited to the CX-313 tube is shown in Fig. 1, Plate 23. The constants of the inductances and condensers used in the filament circuit are "optional" as they will vary with several factors, the most important being the amount of ripple voltage which can be tolerated. Other factors are the maximum load current for which "B" battery eliminator is designed, the smoothness of the rectification obtained from the rectifier elements and the frequency of the AC line voltage. The filter shown is of the kind which has been the "brute force" type, this being the best suited for general service. Frequency traps tuned to the frequency of the supply voltage may be useful where it is known that the line frequency will not change but are not efficient when used on any other than the frequency for which they are designed.

The amount of ripple voltage present is one of the largest factors in determining whether or not the rectifier will be satisfactory under any given conditions. Some receiving sets are very sensitive to small ripple voltages, others are not at all sensitive. In the case of a set using radio frequency amplification, the stability of the radio frequency stages plays an important part. If a tube is on the verge of oscillation, the radio frequency impulses coming thru may be modulated by the ripple voltage, and in such case it will be detached and amplified to the same extent as would a similar disturbance occurring at the transmitting station.

With a properly designed filter circuit no difficulty will be experienced in operating regenerative receivers up to the point of maximum regeneration unless the line voltage is fluctuating badly, in which case the use of type CX-374 Glow Tube as a voltage stabilizer is advisable.

If a separate filter section is provided for the detector voltage, a much greater ripple is permissible as far as the audio stages are concerned. This additional section is not difficult to provide since the detector plate current does not ordinarily exceed 2 milliamperes. In this connection it should be noted that the CX-300A tube will undoubtedly be very popular because of its sensitive detector action and that this same sensitivity causes the requirements for the detector supply voltage to be more critical. Any ripple which may be present will be reproduced with greater intensity. The use of a separate filter for the detector also avoids any coupling between the last audio stage and the detector stage which sometimes causes the distortion or an audio howl, especially if the audio transformers have a resonant point.

Ripple voltage does not change with load current when the CX-374 tube is used because the current thru the filter itself remains constant.

The CX-371 tube requires a fairly heavy plate current, especially if it is operated at high plate voltages. Operation of this tube on 135 volts plate with a corresponding recommended grid bias of -27 volts furnishes ample power for nearly every condition met in ordinary services. The average plate current at 135 volts is 16 M.A., and at 180 volts with 40.5 volts bias is 20 M.A. and requirements should be taken into consideration in estimating the maximum current output which may be required from "B" battery eliminators. The excellent voltage regulation and high current output obtained from the CX-313 is of advantage in making provision for the CX-371 tube.

A filament rheostat may be used to quietly and efficiently control the output voltage but should not be used where the full load current of 65 milliamperes is required as it will result in overheating the tube. With output current of 50 milliamperes or less, filament voltage variation to control the output will prove more satisfactory than the use of high resistances which often become noisy or burn out in service. The filament rheostat knob should be insulated from the body of the rheostat as the filament itself is at positive "B" potential.

Where complete AC operation is desired, one of the quietest systems yet devised is that of using CX-299 tubes with the filaments connected in series, the filament current of 60 milliamperes being supplied from the rectifier. The output tube may be of any convenient type, either CX-112 or CX-371, but it is very important that the plate current taken by this tube be returned thru the series filament connection of the CX-299 tubes in order to reduce the amount of DC current required from the rectifier. The current required by this combination lies between 65 and 70 M.A., which can be supplied by either the CX-313 or CX-316B tube. The filter must be carefully designed because the grid bias required by the CX-299 tubes is most conveniently provided by utilizing the drop across some other tube or a resistance in the circuit, and, with this connection, if there is any variation in current a corresponding voltage is immediately produced on the grid of each tube which, when amplified by that and succeeding tubes, may cause an annoying hum in the speaker.

In connecting "B" eliminators to the ordinary type of receiving sets it will usually be found necessary to ground the filament circuit, or

"B" connection, to the permanent ground provided for the radio set. This connection is already provided in many of the factory built receivers but may not be present in home built or experimental models. When omitted, a pronounced AC hum is often produced.

Measurement of Ripple Voltage: The circuit shown in Fig. 2, Plate 23 has been found very satisfactory for measurement of ripple voltages. The exact amount of ripple voltage present is determined by comparison with a known AC voltage furnished by a step-down transformer. With this type of circuit it is easy to determine whether or not the rectifier is introducing disturbances as the comparison tones will differ in pitch from the ripple tone in such cases.

PROTECTION TUBE TYPE C-377

Comparatively few radio receiving sets are protected against the damage that may be done by connecting the "B" battery to the "A" battery terminals on the set, by accidentally short circuiting the "B" battery thru the wiring of the receiver, or through the use of a damaged tube. Both tungsten lamps and fuses have been used as protective devices but the size of the lamps make an inconspicuous installation difficult and fuses not only have to be replaced but may be burned out again if the source of trouble is not located on the first attempt, and furthermore are not always uniform or reliable. The C-377 Protective Tube fulfills these four functions:

1. **LIMITING "B" BATTERY CURRENT.** Protects tubes batteries, audio and radio transformers and other parts of the receiver against the damaging effects of accidental "B" battery shorts. This protection is especially valuable when storage "B" batteries are used.
2. **GIVES WARNING OF THE OCCURRENCE OF A SHORT CIRCUIT.** The protective lamp lights as a warning if a short circuit occurs while changing tubes or battery connections.
3. **SERVES AS EMERGENCY SWITCH.** When the lamp lights it may be quickly removed from the socket until the socket until the trouble is located and remedied. When the lamp is removed, the "B" battery circuit is automatically opened.
4. **GIVES PERMANENT PORTECTION.** Since the tube does not burn out it is always on duty and there is, therefore, no temptation to short out the protective device as there is when a fuse is blown.

USE OF THE PROTECTIVE TUBE

The C-377 Protective Tube is a reliable and inexpensive protective device which can be readily mounted near the batteries or inside the cabinet so that half may be used to protect the 45 volt "B" battery line to the detector, the entire filament to protect the 90 volt or 90 and 135 volt lines, thus functioning as would two separate fuses. A metal shell automobile type double contact socket, such as the Presto Model 18P, 68P and 128P is suitable, the metal shell being the contact to the center tap of the filament. When used on sets supplied from "B" eliminators, the C-377 provides protection for both the set and the "B" eliminator. It protects the set in case some part of the "B" eliminator fails and also protects the "B" eliminator which may otherwise be damaged by a continued short circuit.

OPERATION OF PROTECTIVE TUBE

When properly connected between batteries and set, the C-377 tube will allow only 85 milliamperes to pass thru it if 90 volts of "B" battery are used. This amount of current is not sufficient to damage the set or the tubes. On short circuit, the C-377 will light and remain lighted as long as the short circuit exists. It may be used to find the source of trouble by removing tubes and checking the wiring since it will cease to light when the cause of short circuit is located. The tube will not burn out on the usual "B" battery voltages of 45 and 90 volts, even when shorted directly across the battery. It may be used with voltages up to 135 volts as there is practically always sufficient resistance in the circuit (such as the speaker or audio frequency transformer windings) to lower the voltage across the lamp to a safe value: thus both the lamp and the receiving equipment are protected. On higher plate voltages the tube should be removed from the socket as soon as the short circuit occurs.

Almost no power is consumed by the protective tube when the radio set is operating normally, provided the "B" battery requirements of the set is operating normally, provided the "B" battery requirements of the set do not exceed 25 milliamperes. With a receiver requiring 20 milliamperes the drop in "B" battery voltage is less than 5 volts. As the "B" batteries deteriorate and the "B" battery current drops, the voltage consumed by the protective lamp becomes negligible. When the filament is cold, the resistance is only 125 ohms, while, at full brilliancy, it rises above 1000 ohms. Very few receivers draw in excess of 25 milliamperes except tuned radio frequency and neutrodyne receivers having six or more tubes when the radio frequency amplifiers operate on 90 volts "B" battery without a "C" battery. In such receivers two C-377 tubes may be connected in parallel.

Since the filament does not glow visibly when properly operated it will always be evident to the user when the current drain is too high for a single C-377 tube as the filament glows dimly when the battery current thru it exceeds 30 milliamperes.

COMPARATIVE MAXIMUM UNDISTORTED OUTPUT

Type	Voltage Plate	Voltage Grid.	Factor Amp.	Plate M. A. Current	Input (RMS) Voltage	Max. A. C. Optimum Resistance Load	Max. Undistorted Power in Watts Output	
C-CX	299	90	-4.5	6.0	2.5	3.1	15000	.0075
C-CX	299	90	-7.5	6.0	1.3	5.3	38000	.015
CX	301A	90	-4.5	8.5	2.0	3.1	12000	.015
CX	301A	135	-9.0	8.5	2.6	6.3	22000	.05
CX	220	135	-22.5	3.3	7.0	16.	7000	.110
CX	112	90	-6.0	7.9	4.0	4.2	11000	.04
CX	112	135	-9	8.0	6.0	6.3	6000	.12
CX	371	90	-16	3.0	11.	11.	3000	.12
CX	371	135	-27	3.0	16,	19.	4000	.35
CX	371	157.5	-33	3.0	18.	28.	4000	.50
CX	371	180	-40.5	3.0	20.	28.	4000	.65
CX	310	180	-12.	7.5	7.0	8.4	8000	.145
CX	310	250	-18.	7.5	12.	13.	12000	.40
CX	310	350	-27.	7.6	18.	19.	11000	.95
CX	310	425	-35	7.7	24.	25.	10000	1.54

The power output given is the MAXIMUM UNDISTORTED OUTPUT for an average tube. In calculating this output, three assumptions were made—(1) that the grid is not allowed to draw current —(2) that the load impedance is adjusted to an optimum value, and (3) that the second harmonic distortion must not exceed 5%.

CUNNINGHAM RADIO TUBES-AVERAGE CHARACTERISTICS

TYPE	USE	"A" BATTERY SUPPLY VOLTS	FILAMENT TERMINAL VOLTS	"A" BATTERY CURRENT AMPS.	"B" BATTERY VOLTS DETECTOR	"B" BATTERY VOLTS AMPLIFIER	NEGATIVE "C" BATTERY VOLTS	PLATE CURRENT MILLIAMPERES	PLATE IMPEDANCE OHMS	MUTUAL CON- DUCTANCE MICROMHOS	VOLTAGE AMPLI- FICATION FACTOR	OVERALL DIMENSIONS CX-TYPE	
												MAX. DIA.	MAX. HEIGHT
CUNNINGHAM C-11 OR CX-12	DETECTOR	1.5	1.1	.25	22 $\frac{1}{2}$	45	0-1.5	1.1	18,000	340	6.2	1 $\frac{7}{16}$ "	4 $\frac{7}{16}$ "
	AMPLIFIER					67 $\frac{1}{2}$ 90	0-3.0 4.5	1.8 2.6	17,000 16,000	360 380			
CUNNINGHAM C- OR CX-299	DETECTOR	3.0	3.3	.06	22 $\frac{1}{2}$ TO 45	45	5-1.5	1.0	19,500	320	6.25	1 $\frac{1}{16}$ "	4 $\frac{5}{8}$ "
	AMPLIFIER	4.5				67 $\frac{1}{2}$ 90	1.5-3.0 4.5	1.7 2.5	16,500 15,000	380 415			
CUNNINGHAM CX-220	POWER AMPLIFIER	4.5	3.3	.125		90 135	16.5 22.5	3.2 7.0	7,700 6,600	428 500	3.3	1 $\frac{3}{16}$ "	4 $\frac{1}{8}$ "
CUNNINGHAM CX-300A	SPECIAL DETECTOR	6.0	5.0	.25	45			1.5	30000	670	20		
CUNNINGHAM CX-301A	DETECTOR AMPLIFIER	6.0	5.0	.25	45	45	5-1.5	0.9	18,500	460	8.0	1 $\frac{13}{16}$ "	4 $\frac{7}{16}$ "
						67 $\frac{1}{2}$	1.5-3.0	1.7	14,000	600			
						90	4.5	2.0	12,000	710			
						135	9.0	5.8	5,500	1435			
						157	10.5	7.9	4,800	1670			
						180	40.0	20.0	2,100	1430			
CUNNINGHAM CX-112	POWER AMPLIFIER	6.0	5.0	.50		90	6.0	2.4	8800	890	8.5	1 $\frac{13}{16}$ "	4 $\frac{11}{16}$ "
CUNNINGHAM CX-371	POWER AMPLIFIER	6.0	5.0	.50		90	16.0	11.0	2500	1200	3.0	1 $\frac{13}{16}$ "	4 $\frac{11}{16}$ "
						135	27.0	16.0	2200	1360			
						157	33.0	18.0	2150	1400			
						180	40.0	20.0	2,100	1430			
CUNNINGHAM CX-310	POWER AMPLIFIER OSCILLATOR	8.0	7.5	1.25		180	12.0	7.0	7,000	1100	7.8	2 $\frac{3}{16}$ "	5 $\frac{5}{8}$ "
						250	18.0	12.0	5,600	1330			
						350	27.0	18.0	5,100	1500			
						425	35.0	24.0	5,000	1550			
CUNNINGHAM CX-300	SPECIAL DETECTOR	6.0	5.0	1.00	16 TO 22 $\frac{1}{2}$						1 $\frac{13}{16}$ "	4 $\frac{7}{16}$ "	
CUNNINGHAM CX-313	FULL-WAVE RECTIFIER		5.0	2.0	MAX. A. C. VOLTAGE PLATE TO FILAMENT 220* PER ANODE			MAX. D. C. LOAD CURRENT (MILLIAMPERES) 65			2 $\frac{3}{16}$ "	5 $\frac{5}{8}$ "	
						7.5	1.25	550*			65		
CUNNINGHAM CX-316 B	HALF-WAVE RECTIFIER		7.5	1.25	550*			65			2 $\frac{3}{16}$ "	5 $\frac{5}{8}$ "	
CUNNINGHAM CX-374	VOLTAGE REGULATOR TUBE		RATED VOLTAGE		STARTING VOLTAGE			MAX. D. C. CURRENT			2 $\frac{3}{16}$ "	5 $\frac{5}{8}$ "	
			90 VOLTS D. C.		125 VOLTS D. C.			50 MILLIAMPERES					
CUNNINGHAM C-376	BALLAST TUBE		CURRENT 1.7 AMPERES		VOLTAGE RANGE 40 TO 60 VOLTS			STD MOGULTYPE SCREW BASE			2 $\frac{1}{16}$ "	8"	
CUNNINGHAM C-377	PROTECTIVE TUBE		CURRENT		VOLTAGE DROP ACROSS HALF FIL. ENTIRE FIL.			BASE DOUBLE CONTACT BAYONET AUTOMOBILE TYPE			1 $\frac{7}{16}$ "	2 $\frac{1}{2}$ "	
			20 MILLI. 90 MILLI.		2.5 5.0 4.5 90								

*NOTE: R.M.S. AS INDICATED ON A.C. VOLTMETER.

At the present time so much interest is centered around the new A.C. tubes that we believe further information concerning them will be of interest to our readers. We are indebted for much of the following data to an Engineering Bulletin recently issued by the E. T. Cunningham Laboratories.

We will discuss the general principles of operation of two distinct types of A.C. tubes, namely: the—26 A.C. Filament Type (UX-226 or CX-326) and the—27 Separate Heater Type (UY-227 or C-327).

The—26 type of tube is designed for use as a radio or an audio amplifier and has the same characteristic as the UX-201A or CX-301A, except that the mutual conductance is somewhat higher. It is equipped with the standard UX four prong base and has an oxide-coated ribbon type of filament which is heated with "raw A.C." consuming, however, a larger current at a lower voltage than the D.C. tubes, i.e., 1.05 amperes at 1.5 volts A.C.

It has been found possible, by a careful choice of filament current and voltage ratings, to obtain a close balance between the electromagnetic and electrostatic fields set up within the tubes by the alternating current, thereby minimizing the so-called "grid effect" of the filament and other undesirable conditions. This balance is made to occur under the condition at which the tube operates most successfully as an amplifier.

Figure 1 shows the plate impedance R_p and mutual conductance G_m of this tube plotted against the effective plate voltage E_p . It

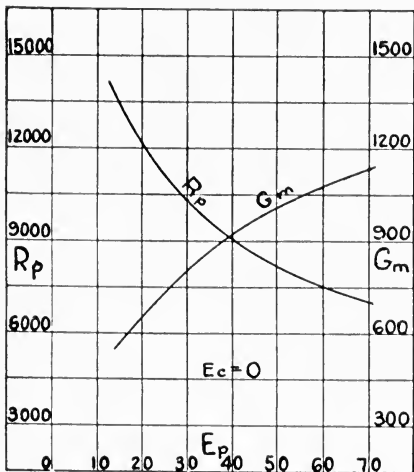

Fig. 1

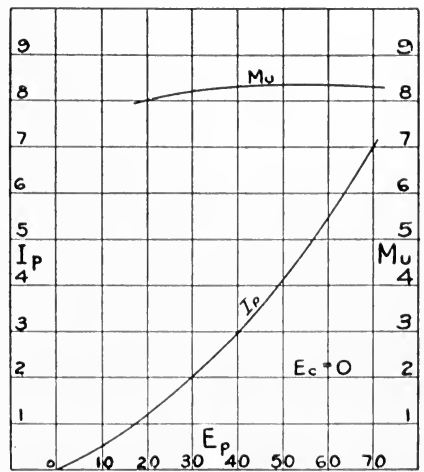

Fig. 2

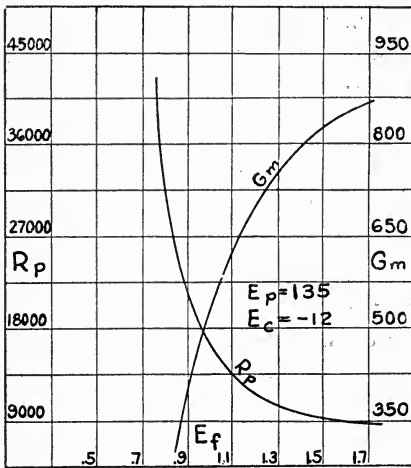

Fig. 3

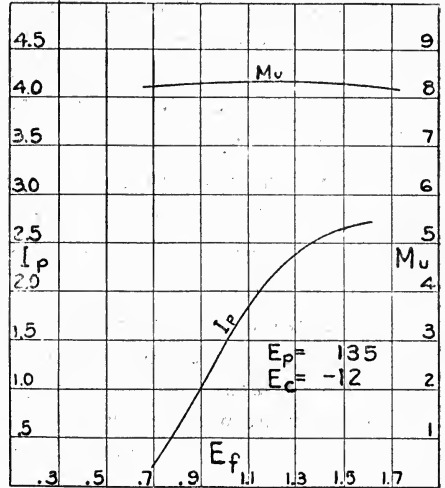

Fig. 4

should be noted that the curve is drawn for the case of zero grid voltage which, of course, is not the normal operating condition. The curve may be used, however, to obtain the ordinate values, corresponding to any magnitude of grid bias, by determining the "effect plate voltage" in each case, that is, by subtracting from the actual plate voltage the product obtained by multiplying the grid bias voltage by the amplification constant M_u of the tube. For example, if the tube is being used with 135 volts on the plate and with -12 volts grid bias, the effective plate voltage is $[135 - 12 \times 8.2]$ or 36.6 volts. Thereby we see from the curves that the plate resistance and mutual conductance are 9600 ohms and 870 micromhos respectively.

Figure 2 shows the plate current I_p and amplification constant M_u plotted against the effective plate voltage.

Figures 3 and 4 show the variation of R_p , G_m , I_p and M_u as the filament voltage E_f is varied. The flatness of the R_p curve from 1.3 to 1.7 volts on the filament indicates that the tube is relatively insensitive to voltage fluctuations over this range and hence is not bothered by variations in the supply line.

Figure 5 gives the circuit arrangement whereby the amount of "ripple voltage" in the plate circuit of a tube, heated with A. C., may be measured by comparison with a known voltage from the source. With the switch in the "A" position the amount of ripple in the plate circuit may be read on the vacuum tube voltmeter. The switch is then thrown to the "B" position and the same reading on the meter obtained by adjusting the calibrated potentiometer P. This comparison method

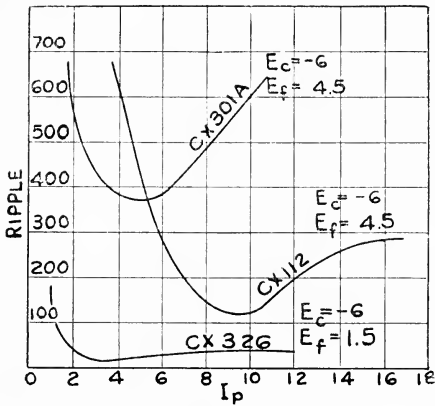

Fig. 5

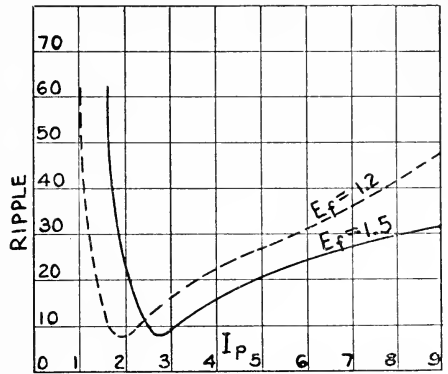

Fig. 6

obviates the necessity of a direct calibration of the vacuum tube voltmeter and associated amplifier. Such a scheme gives, of course, merely the total hum voltage with no indication of the relative amounts of fundamental and harmonic frequencies.

By the use of this apparatus the data given in Figure 6 were obtained. Here the ripple (millivolts) existing in the plate circuit of the -26 tube at various values of plate current is shown. The values of plate current were chosen as abscissae instead of plate voltage in order to bring out the fact that minimum hum occurs at a plate current of about three milliamperes, the exact position varying only slightly with changes in grid voltage, but to a larger extent with changes in filament voltage as indicated in the dotted curve which shows the readings obtained when the filament voltage is reduced to 1.2. It will be noted that the grid bias recommended for the -26 is such that a plate current between three and four milliamperes is produced. This value is recommended because of the fact the increase in ripple voltage at low values of plate current is very sharp so that it is better to operate slightly above the minimum point of the average tube rather than below the minimum.

It is evident that the -26 tube does not offer good possibilities for use as a detector using grid bias detection (plate rectification) since the ripple voltage is very high at low values of plate current. The very low minimum of hum obtained when the proper value of plate current is maintained results in an excellent performance of the tube when used as a radio frequency or audio frequency or audio frequency amplifier.

In Figure 7 the —26 tube is compared with Types CX-112 and CX-301A, the latter tubes being adjusted to their best operating point. A large reduction in ripple voltage, accomplished by the special filament design chosen for the —26, is clearly indicated in this figure.

It is essential for the correct operation of the —26 tube that the grid and plate returns (C+ and B—) be connected to the exact center or neutral point of the A.C. supply system, particularly when the tube is used as an audio frequency amplifier. The rapid rise in ripple voltage with departure from the correct balance point is shown in Figure 8.

To satisfy this condition the grid return may be attached to the center point of a resistance unit connected directly across the filament terminals. Under certain conditions it may be desirable to employ a low resistance potentiometer, affording thereby an adjustable center tap which will allow for the eccentricities of individual tubes or variation in the supply line balances.

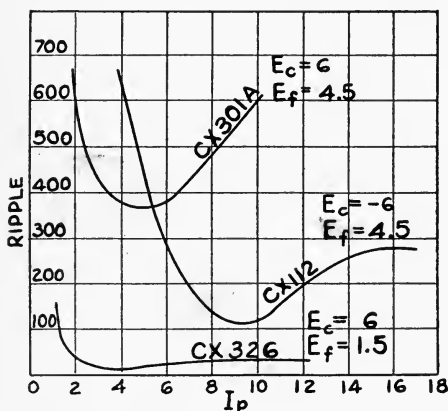

Fig. 7

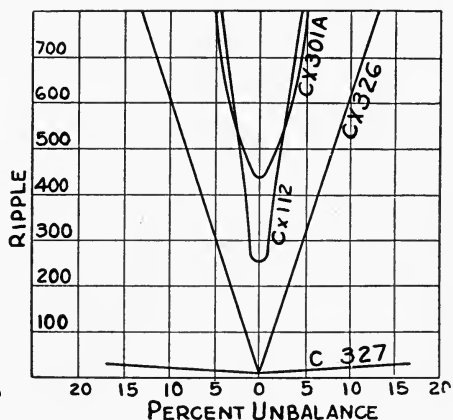

Fig. 8

A comparison of the ripple voltage from four types of tubes is shown in Figure 8, the minimum for the CX-301A and CX-112 being slightly higher than in the previous figure since they were operated at five volts on the filament when taking these data. This curve shows the much lower minimum given by the —26 and also indicates that the grid return adjustment is less critical. We see that the grid return on the —27 type of tube is not at all critical because of the use of a separate heater element.

The —26 tube gives essentially the same performance as the UX-201A or CX-301A when used as a radio frequency amplifier since the inter-electrode capacity and other characteristics are practically identi-

cal. It is necessary in this case, however, to use a grid bias because, unlike storage battery tubes, operation without grid bias causes an uneven flow of grid current, resulting in a modulation and distortion of the incoming radio frequency signals, together with a marked decrease in amplification. When operated at the recommended grid bias, however, the ripple voltage is so low that any modulation of the carrier is not appreciable unless the radio frequency stages are unstable and tend to oscillate. The radio frequency grid returns may be connected to the center tap of a resistance across the filaments as they do not require a critical adjustment. R. F. bypass condensers across this resistance are sometimes advisable.

The—27 is a tube of the indirectly heated type, having a cathode, or electron-emitting member, consisting of an oxide-coated metal cylinder in place of the usual filament. Inside of this cylinder, and insulated from it, is placed the heater filament which requires 1.75 amperes and 2.5 volts A.C. For this reason the tube cannot be operated in parallel from the transformer winding supplying the —26 tubes. Other considerations of circuit design likewise make it desirable to have a separate winding for this tube. The —27 is also similar in characteristics to the UX-201A or CX-301A, although it is slightly higher in mutual conductance and considerably lower in inter-electrode capacity. This tube is intended primarily as a detector used in conjunction with the —26 and is mounted on a special five-prong base. The —27 is particularly adapted to detector service because of its freedom from ripple voltage at low plate currents, which permits the use of either grid leak or grid bias detection. When detector sensitivity is not an important factor grid bias detection (plate rectification) may be used. A greater amount of audio amplification may be employed when using the —27 tube as a detector rather than any of the "raw A.C." types. Figures 9 and 10 show the variation of R_p , G_m , I_p μ , with respect to effective plate voltage in the case of the —27 type, while Figure 8 indicates its extreme freedom from ripple.

Since the —27 tube uses an indirectly heated cathode it takes longer for it to reach an operating temperature than is the case with tubes in which the cathode is heated directly. The curve in Figure 11 shows that an average tube starts to operate at about twenty seconds and comes to normal operation at the end of thirty to forty seconds after the heating current turned on.

To compete with battery receivers it is essential that sets employing A. C. filament tubes compare favorably with them in respect to all important operating characteristics, including tone quality, volume, sensitivity, selectivity, and freedom from hum, power line dis-

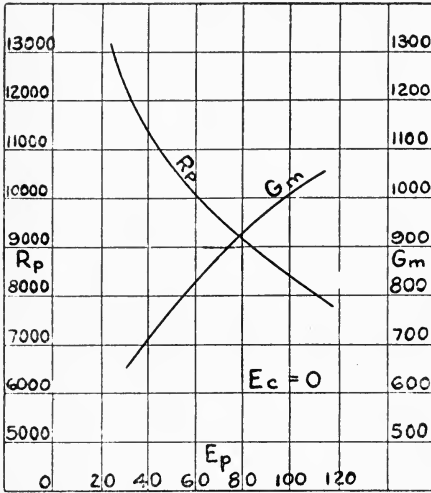

Fig. 9.

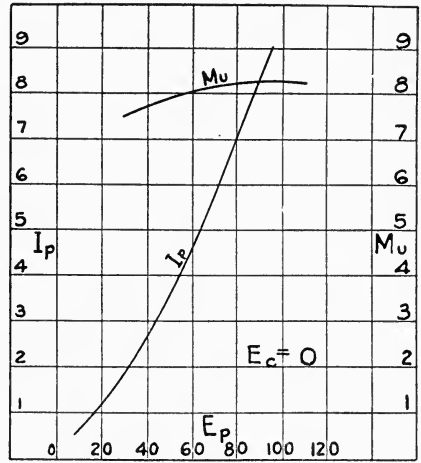

Fig. 10.

turbances, and service troubles. The cost and weight of component parts is also an important consideration.

One of the most important requisites for obtaining true tone quality is the use of a tube in the last stage of the audio amplifier that is designed to handle the necessary power output without distortion. In this respect the Type UX-171 or CX-371 is strongly recommended. Used only in the last stage, the filament of this tube may be heated directly with "raw A.C." at the proper voltage and, with a center tap resistance for grid return and the proper bias and plate voltages, the operation will be about as satisfactory as if the filament were heated by a storage battery.

The sensitivity and selectivity of the radio frequency stages is essentially the same with the—26 tubes as with the —01A. The high mutual conductance of the—26 is partly offset by the necessity of using a grid bias, which is contrary to common practice in the use of the D.C. tubes. The sensitivity of the detector plays an important part in determining the overall sensitivity of the receiver. When the —27 type is used grid leak detection sensitivity, as compared with battery operated receivers, is obtained.

With respect to freedom from hum, the —26 and —27 combination affords very satisfactory results if the proper precautions with respect to circuit design are followed. The ripple voltage given by each type, shown on the attached curves, is actually a combination of 60 cycle and 120 cycle components with a small amount of higher harmonics. A direct comparison under operating conditions shows that the amount

of ripple voltage introduced by the A.C. filament supply is of the same order of intensity as that given by the better types of plate supply devices and is not audible more than a few inches from the loudspeaker.

To obtain freedom from line disturbances care must be taken to prevent the direct pick-up of such disturbances by the tubes an associated equipment. Power transformers should be shielded if placed in the same cabinet with the receiver and, under certain conditions, an electrostatic shield between the primary and secondary windings of the transformer is desirable.

The rugged design of both types of A.C. tubes insures freedom from service troubles as far as the tubes themselves are concerned. By the elimination of all devices requiring corrosive liquids, the possibility of corroded connections disappears and it is evident that, with the proper care in circuit design and the use of high grade material in parts, a greater measure of freedom from service troubles can be secured than has been possible with previous designs of radio receivers. Furthermore, the annoyance of storage battery attention or the trouble and expense of dry cell renewals is removed by the use of a removed by all of its electrical house-lighting socket.

With respect to the socket and bulk of component parts, this A.C. tube combination is particularly satisfactory since the use of a heavy and expensive A filter system or A supply unit is avoided, for the necessary A voltages may be obtained merely by adding a few turns of wire to the power transformer supplying the plate supply unit or by the use of a small separate transformer designed for this purpose.

The combination of the —26 tubes as radio and audio amplifiers with the —27 as a detector, makes possible the same overall performance, tube for tube, as is obtainable with battery operated receivers.

For the past several seasons the trend has been toward complete battery elimination. Many satisfactory plate supply units operating from A.C. have been developed, but filament operation from an A.C. source has presented more of a problem, due to the larger currents required and increased expense in the rectifier and filter circuit.

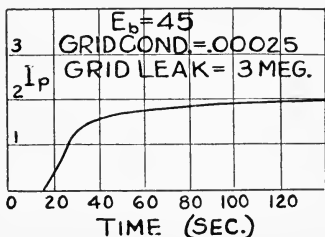
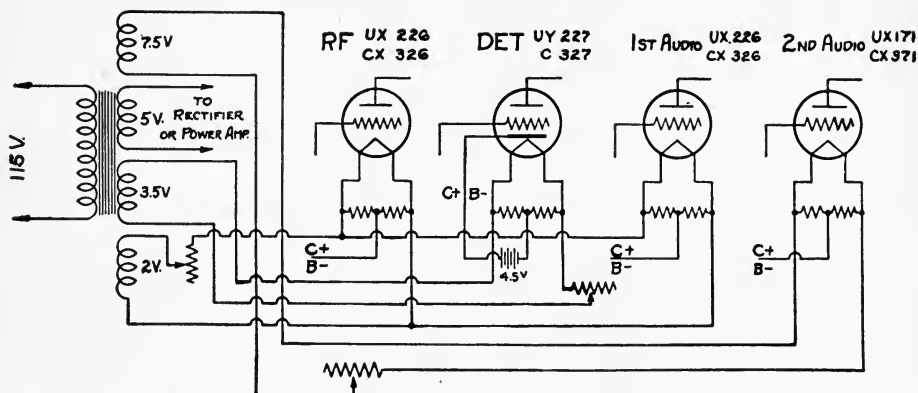

Fig. 11.



The newly announced A.C. tubes offer an excellent solution to this problem.

The above diagram shows how to adapt the filament wiring of the popular type of receiver to A.C. operation.

RADIOTRON UX 222

For over a year the Transoceanic Silver Ghost and Transoceanic Phantom model receivers have had provision to add negative bias to the radio frequency amplifier tubes. However the instruction books call for this bias to be omitted which immediately raises the question why is this bias to be omitted; which immediately raises the question why is this bias binding post provided if it cannot be used. This binding post for applying negative bias to the tuned radio frequency amplifiers was supplied anticipating the introduction of a special purpose radio frequency amplifier vacuum tube which would be considerably superior to any available tubes suitable for radio frequency amplifiers.

This special radio frequency amplifier tube has just been announced, the Radiotron UX-222 and the Transoceanic Silver Ghost and Transoceanic Phantom are the only two receivers on the market today that can immediately use these new tubes to decided advantage without any changes in the receiver. The Radiotron UX-222 is known as a four element tube as it has two grids, as well as the usual filament and plate. The standard tube base is used (four prong) the fifth connection being taken at the top of the tube.

The standard tube has but one grid, the new tube has two grids one placed concentrically within the other and with the filament element. This is entirely different from ordinary tube construction. The "con-

trol grid" element which corresponds to the regular grid in an ordinary three element tube is brought out to a terminal at the top of the glass portion. The other grid element is brought out to the old grid position of the UX socket and is known as the "screen grid."

This new development is not supposed to render old radio frequency amplifier tubes or receivers obsolete, but is presented as an improvement applicable to radio frequency amplifiers. The tube has two distinct advantages: 1st. when the "regular grid is connected to the tuning coil and the proper B and C voltages applied, the tube is automatically neutralized, preventing any feed back, or unstabilized operation. Neutralizing devices are not required to neutralize the capacity of the tube as it is neutralized within itself. Therefore in an otherwise unbalanced circuit the system becomes very stable and is free from self oscillations or howls.

2nd—the application can be a "space-charge-grid" tube by reversing the grid connections. This enables a very high voltage amplification and consequent signal gain, the actual amount depending upon the design of the radio frequency transformers principally. It is understood that in each case the tube must be surrounded by a metal shield, the top grid connection being brought out through this shield. The control grid and plate wires must be kept well separated. The metal shield of the tube must be connected to either the positive or negative A battery terminal, at the tube socket.

In the first application of the UX-222, where automatic neutralization is obtained, the control grid is supplied with a bias of 1 to $1\frac{1}{2}$ volts negative. In addition the screen grid is provided with a positive bias of 45 volts, this can be obtained by connecting to 45 volts of the plate supply battery. With the above bias voltages the plate voltage recommended is 135 volts.

In the second application to radio circuits, the outer or screen grid becomes the control grid and is biased with from 0 to $1\frac{1}{2}$ volts negative. The space charge grid then performs in another capacity and is biased with $22\frac{1}{2}$ volts positive by connecting to the plate battery. The suggested plate voltage is then 135 to 180 volts. The 180 volts would be particularly suited in an audio amplifier where resistance coupling was used and in this case a suitable plate resistor would be $\frac{1}{10}$ and $\frac{1}{4}$ megohm.

This tube will raise the amplification obtained from thirty to forty times over that secured with the conventional tube, using the self neutralizing system first mentioned above. Used as a space-charge-grid tube the received signal voltage may be increased by more than 150 times per stage.

This new tube requires but .0132 ampere filament current at a filament voltage of 3.3 and therefore can be operated on three dry cells or from a six volt storage battery through a suitable rheostat. Using such a rheostat the drop of potential across the rheostat may be used to obtain the low bias required for one of the grids.

As the interelectrode capacity is eliminated the selectivity of a receiver using such tubes should be at a maximum. Furthermore the greatest gain will be due to their use in radio frequency amplifiers as the efficiency of a detector tube increase very rapidly with any increase in signal voltage applied to the detector grid.

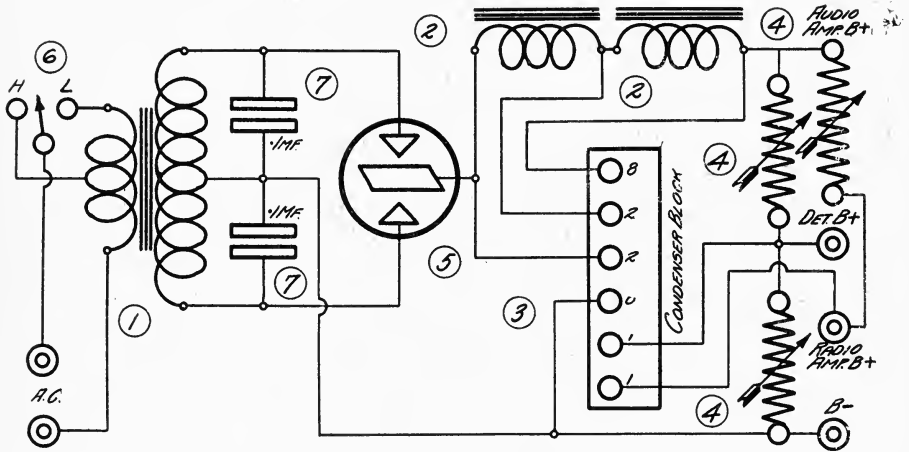

"B" Current Supply using the Raytheon BH tube to give a maximum plate voltage of 180 and lower plate voltages (adjustable) for the detector and radio frequency amplifier tubes.

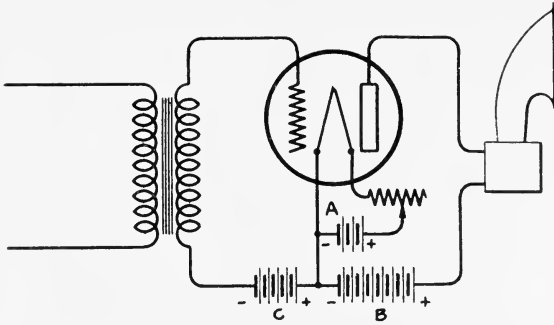

FIG. N^o 1

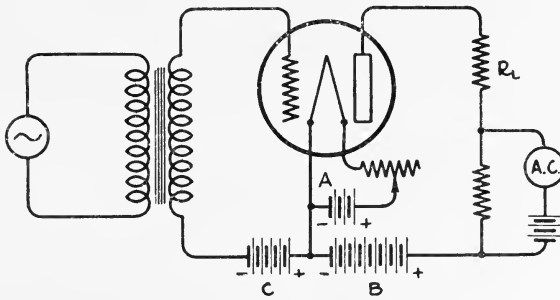

FIG. N^o 2

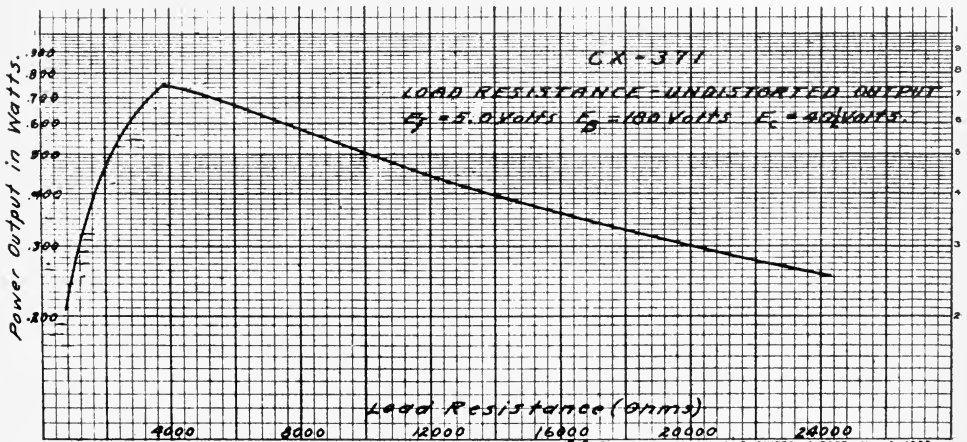

FIG. N^o 3

E. T. CUNNINGHAM, Inc., N. Y. ENGINEERING DEPT., MAY 1, 1928

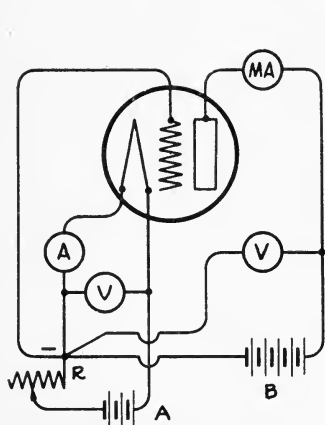
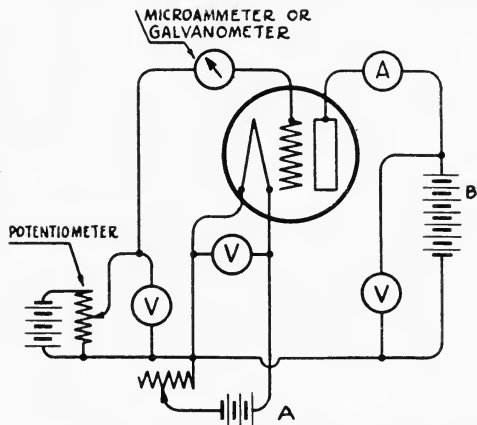

PLATE CURRENT TEST CIRCUIT
(ZERO GRID VOLTAGE)

FIG. N^o 1



GRID VOLTAGE PLATE CURRENT TEST CIRCUIT.

FIG. N^o 2

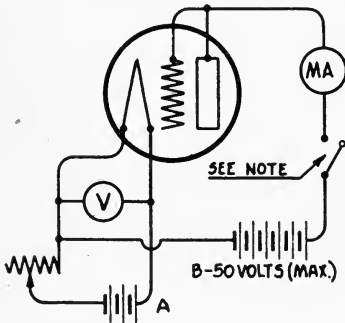

EMISSION TEST CIRCUIT.

FIG. N^o 3

NOTE
CLOSE SWITCH JUST LONG ENOUGH TO GET
READING ON MILLIAMETER AFTER TUBE HAS
BEEN INSERTED IN SOCKET AND FILAMENT
VOLTAGE ADJUSTED TO RATED VALUE.
(DISREGARD CHANGE IN FILAMENT VOLT-
METER READING WHICH WILL OCCUR
WHEN EMISSION CURRENT FLOWS)
TEST FOR SHORTED ELEMENTS BEFORE
TAKING EMISSION READINGS OR USE PROTECTIVE
DEVICE

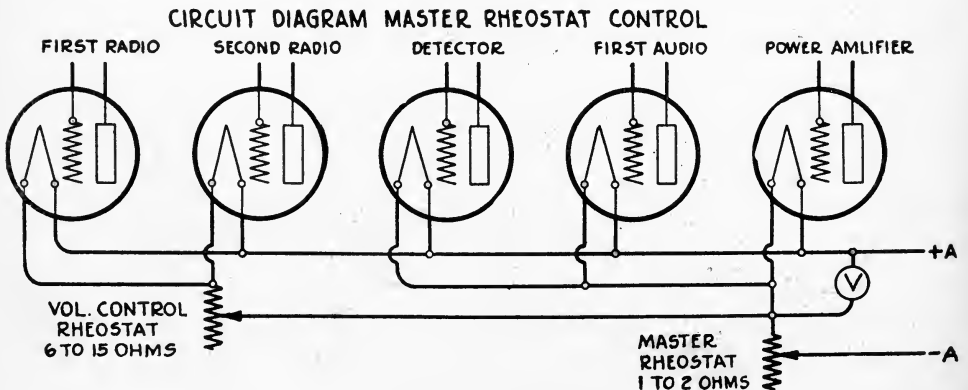

THORIATED TUNGSTEN FILAMENT REACTIVATION
A.C. APPARATUS AND CIRCUIT ARRANGEMENT.

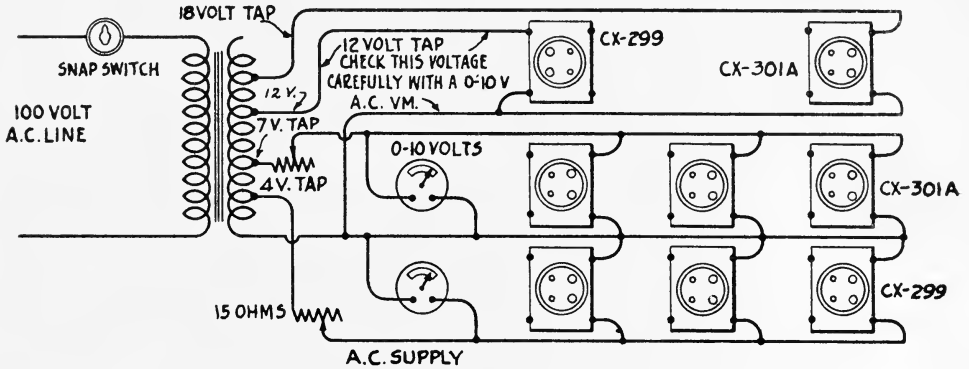

When D.C. is used, the following equipment will give excellent results:

- 1 6 volt storage battery
- 1 24 " " "B" battery (at least 4500 m.a. hrs. capacity)
- 1 Weston Model 301 Voltmeter or equivalent (0-8 volts range)
- 1 " " 301 " (0-25 volts range) or a two scale instrument
- 2 25 ohm rheostat
- Sockets as required

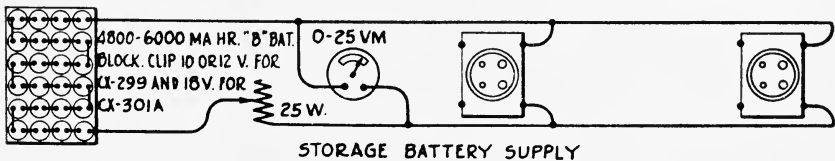
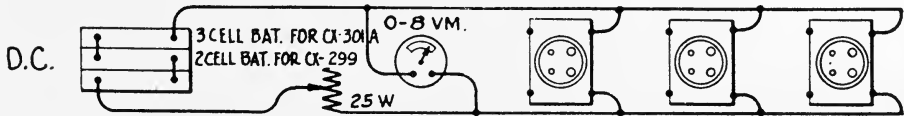

D.C. FILAMENT SUPPLY

CX 371

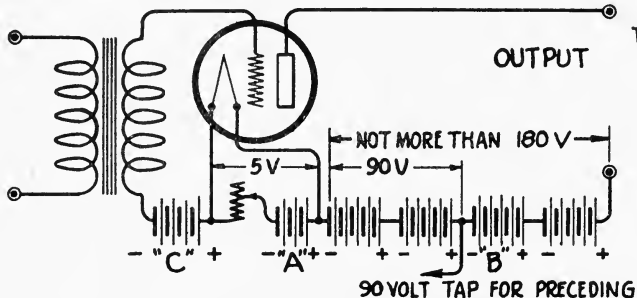

TYPICAL OUTPUT CIRCUIT NO. 1.

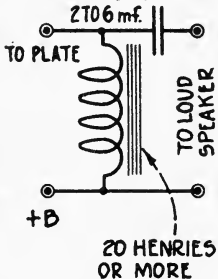

A.C. FILAMENT SUPPLY

CX 371

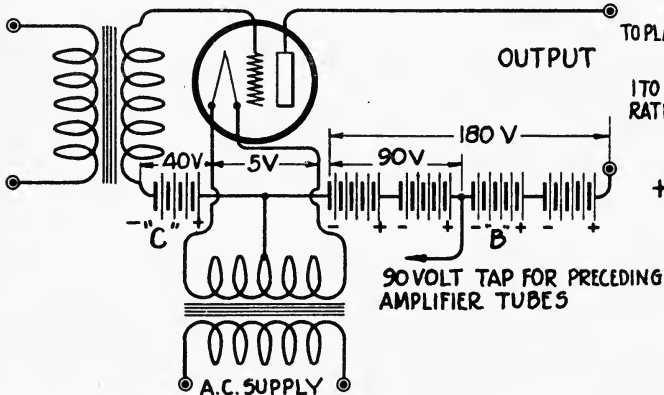

TYPICAL OUTPUT CIRCUIT NO. 2.

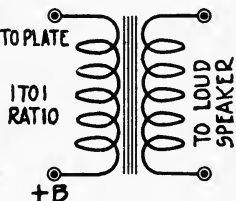

OUTPUT CIRCUITS NO. 1. AND NO. 2. MAY BE USED INTERCHANGEABLY TO KEEP D.C. OUT OF LOUD SPEAKER WINDING.

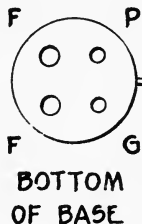
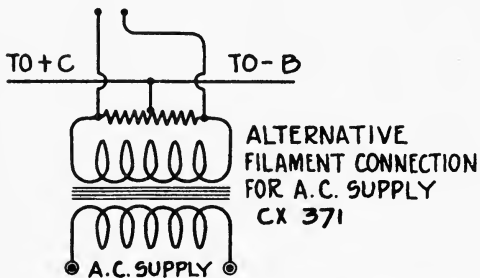

METHODS OF SECURING VARIOUS NEGATIVE GRID BIAS VOLTAGES

40½ VOLTS GRID BIAS

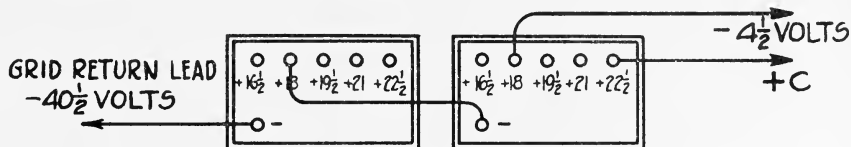

TWO 22½ VOLT (TAPPED) "B" BATTERIES
USED AS "C" BATTERIES

31 VOLTS GRID BIAS

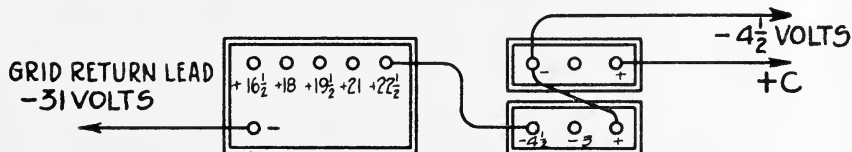

ONE 22½ VOLT (TAPPED) "B" BATTERY
AND TWO 4½ VOLT "C" BATTERIES

27 VOLTS GRID BIAS

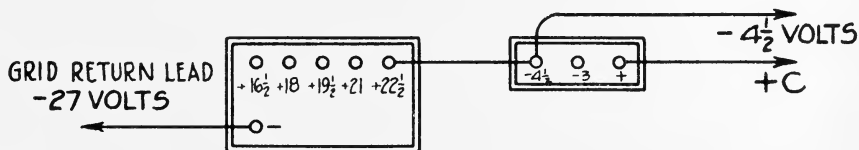

ONE 22½ VOLT "B" BATTERY (TAPPED OR WITHOUT
TAPS) AND ONE 4½ VOLT "C" BATTERY

16½ VOLTS GRID BIAS (FOR 90 VOLTS "B")

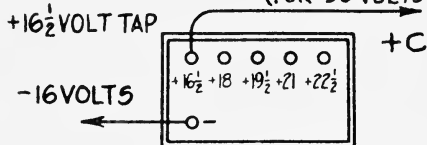

ONE 22½ VOLT (TAPPED) "B" BATTERY
USED AS "C" BATTERY

15 VOLTS GRID BIAS

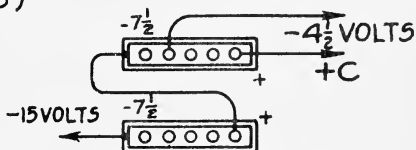

TWO 7½ VOLT "C" BATTERIES
IN SERIES

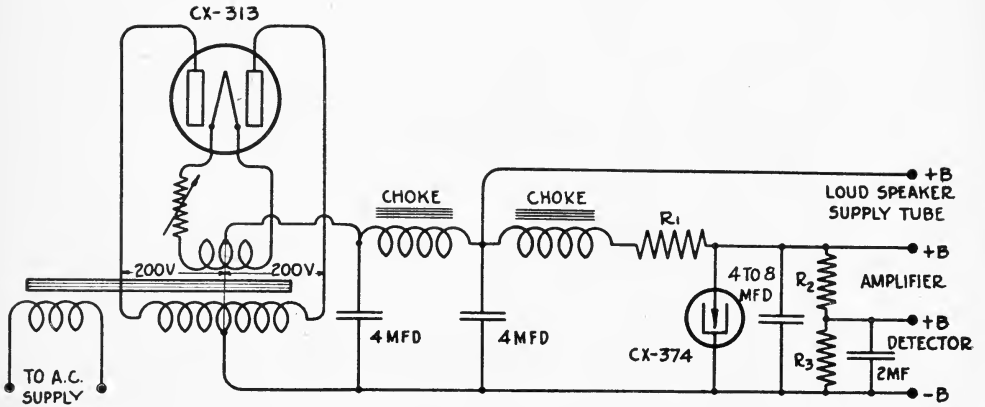

FIG. N^o 1

- $R_1 = 2500$ Ohms
- $R_2 = 5000$ Ohms
- $R_3 = 7500$ Ohms

RIPLLE TEST FOR "B" ELIMINATORS

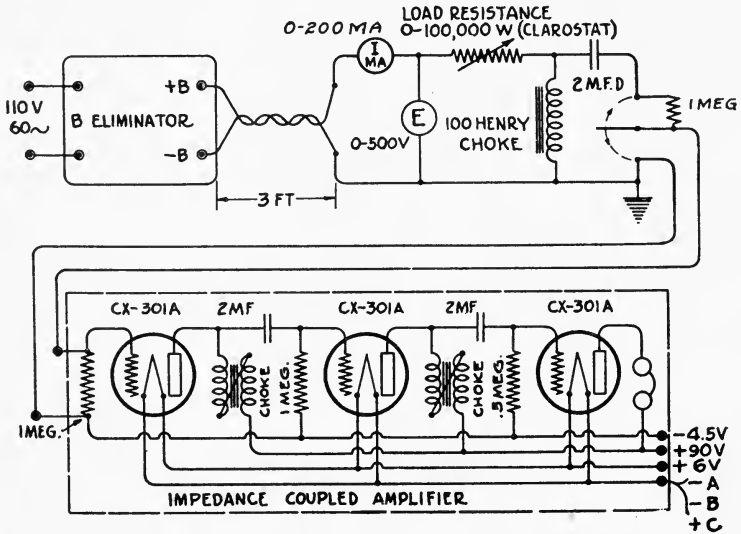
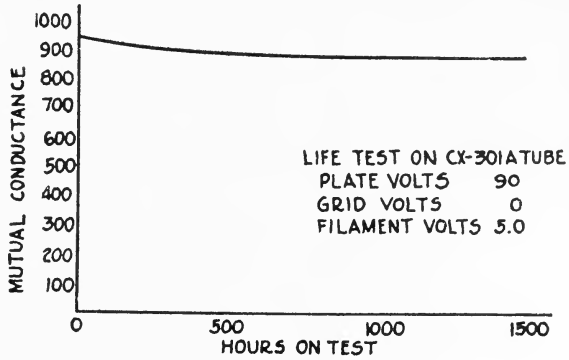

Plate No. XXIII

THORIATED TUNGSTEN FILAMENT REACTIVATION



CIRCUIT DIAGRAM TUBE REACTIVATION

FLASHING VOLTAGE

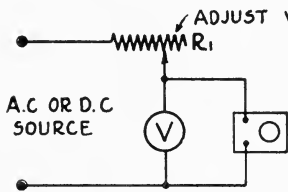

BURNING VOLTAGE

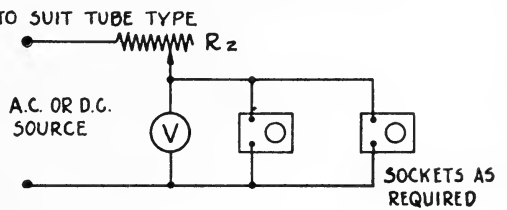

REACTIVATION OF CX 299 AT VARIOUS VOLTAGES

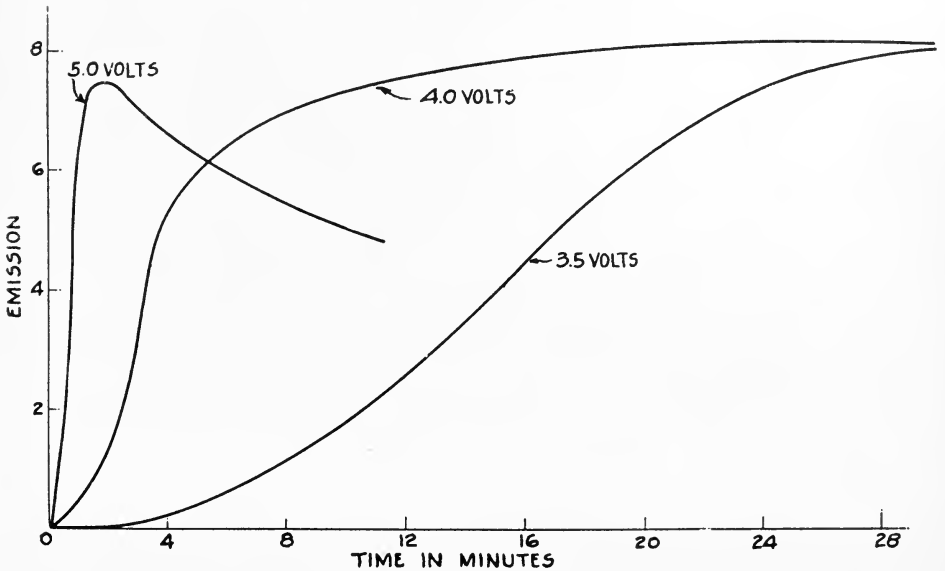

CUNNINGHAM RADIO TUBE CX-300A

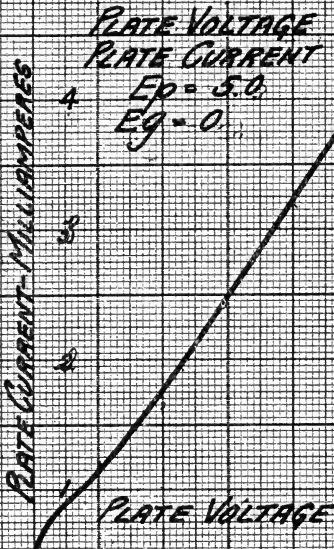

20 40 60 80 100

FIG. 1

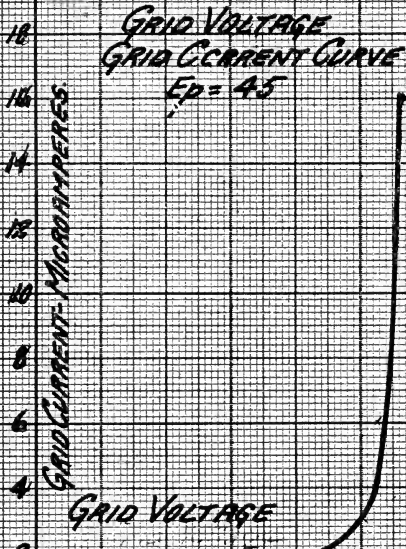

-4.0 -3.0 -2.0 -1.0

FIG. 2

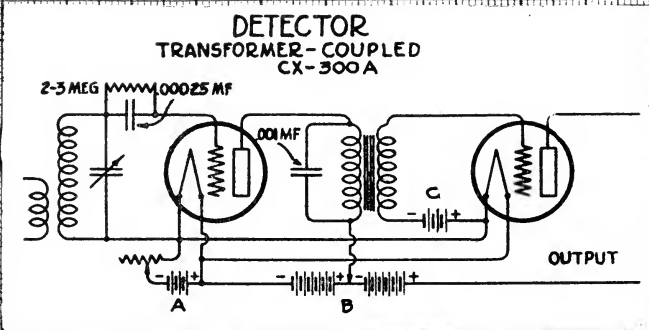
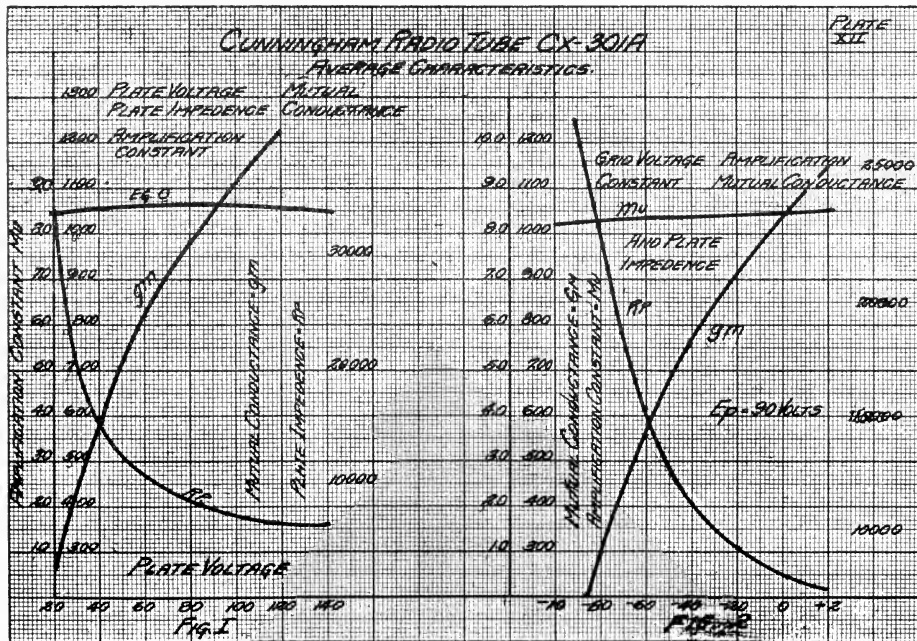
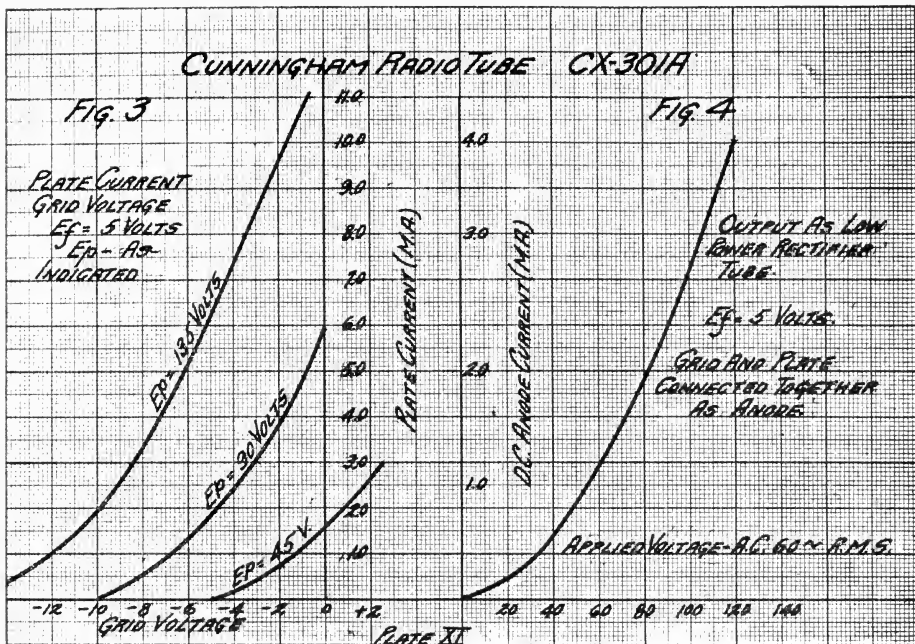
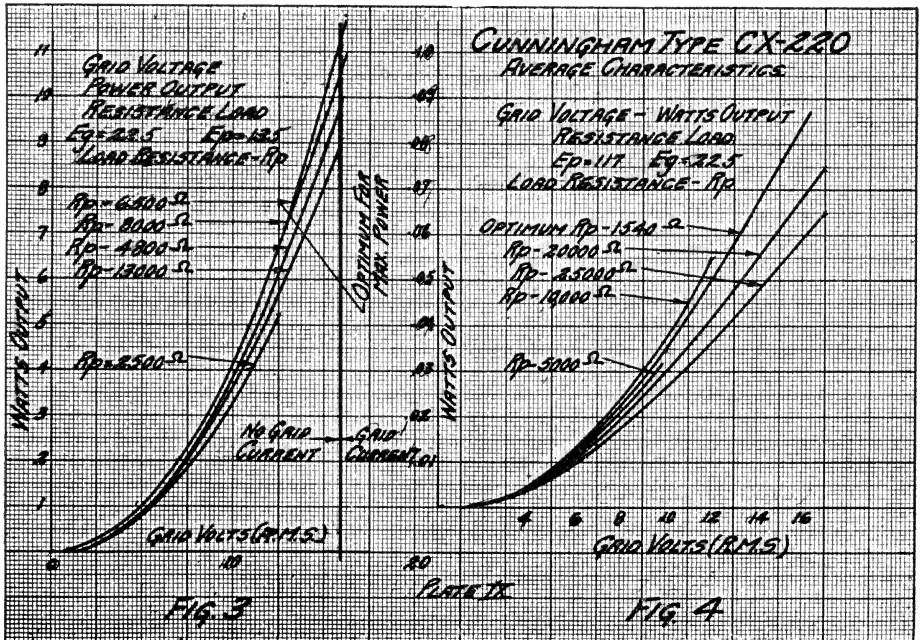
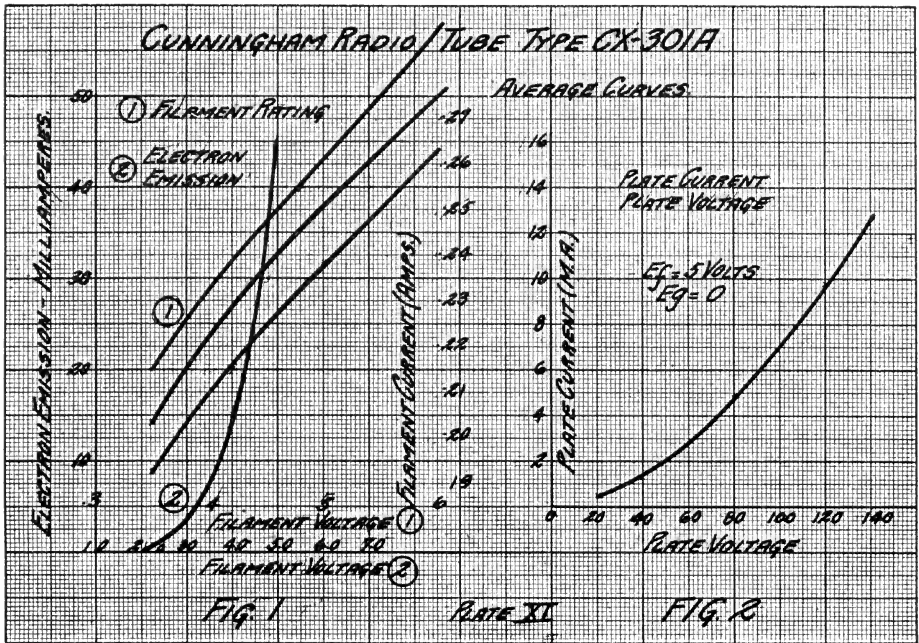
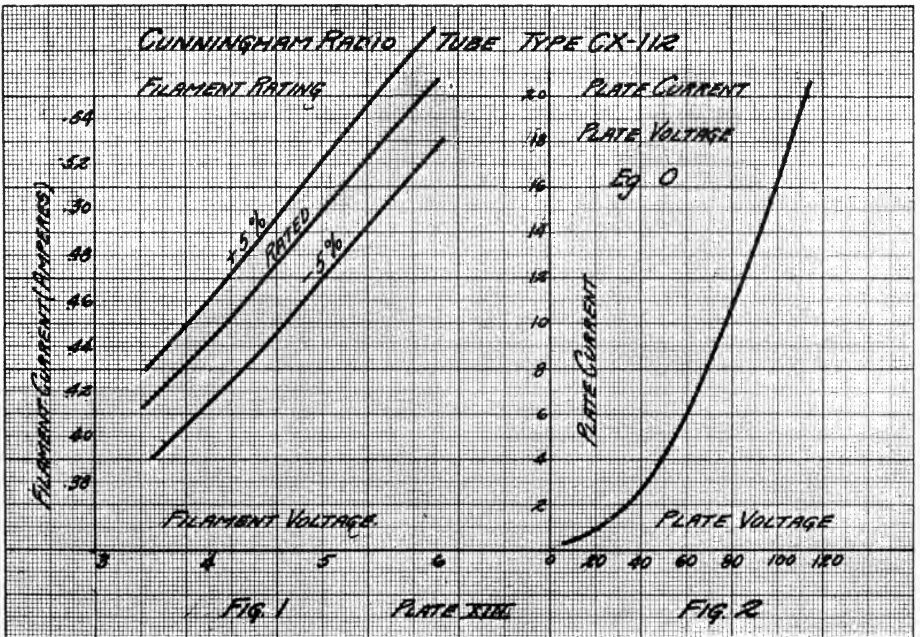
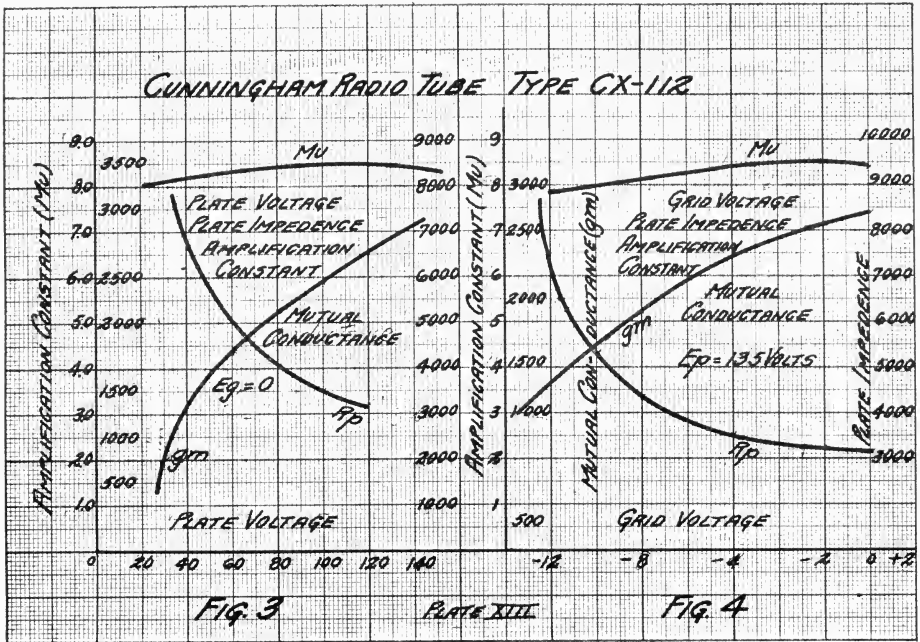
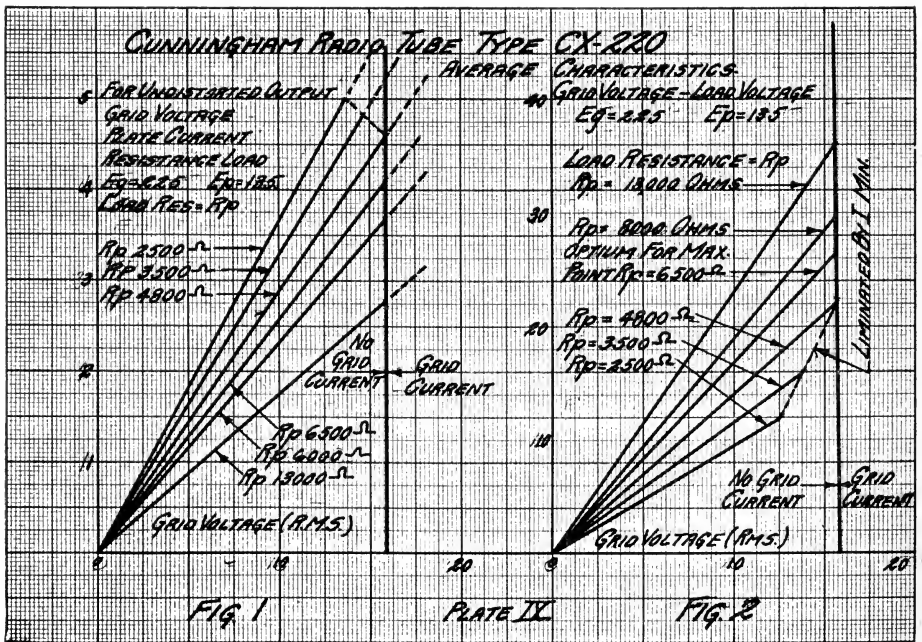
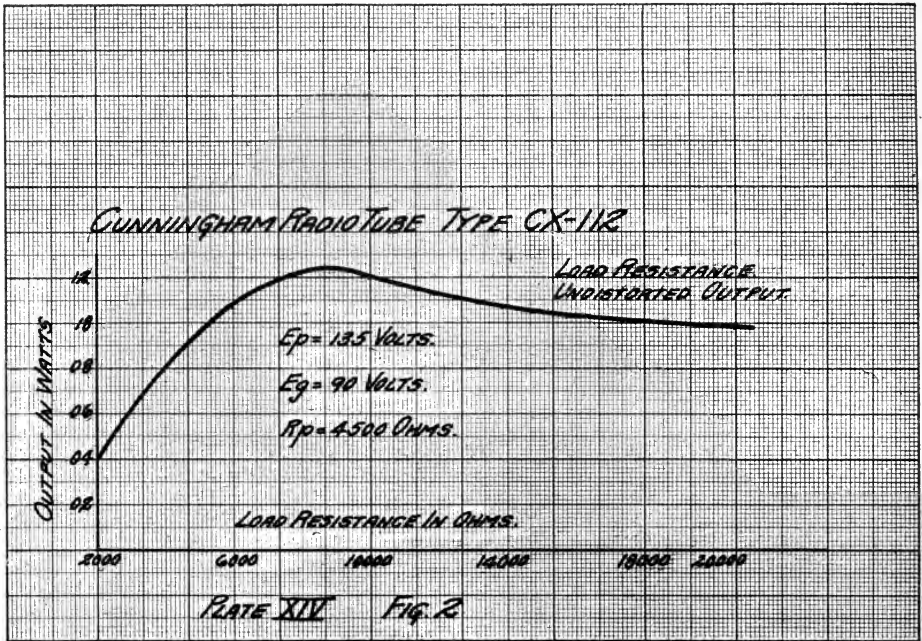

PLATE E_p









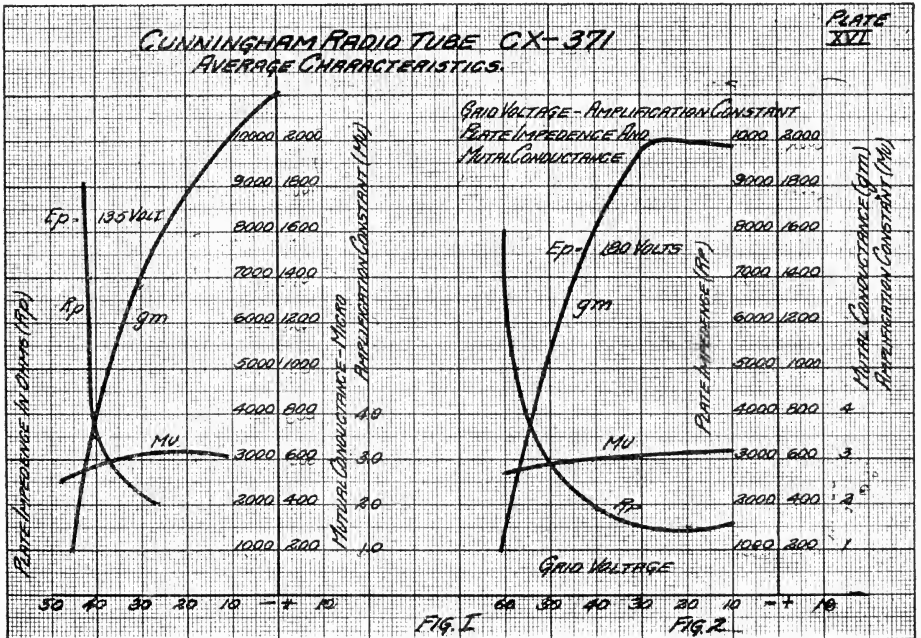
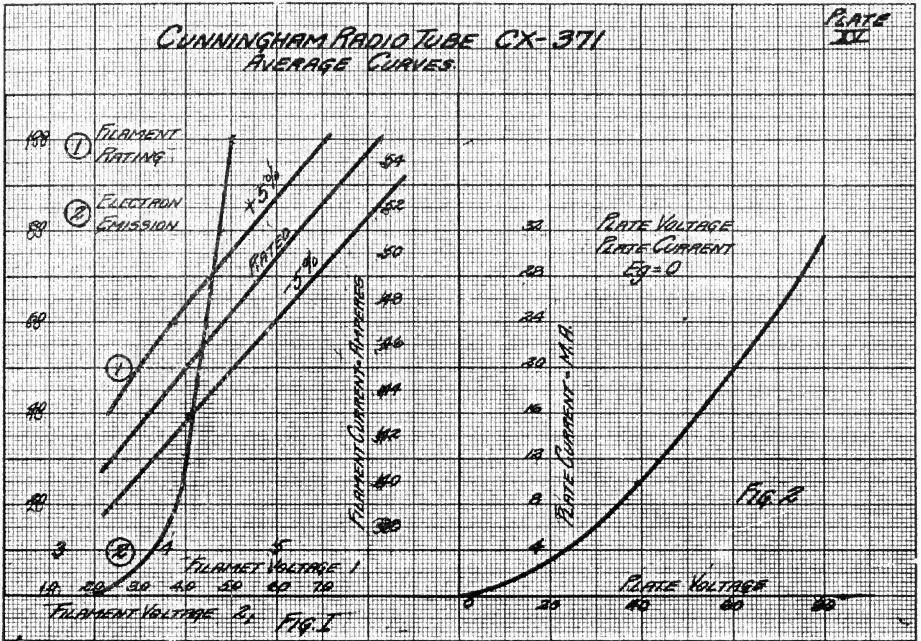

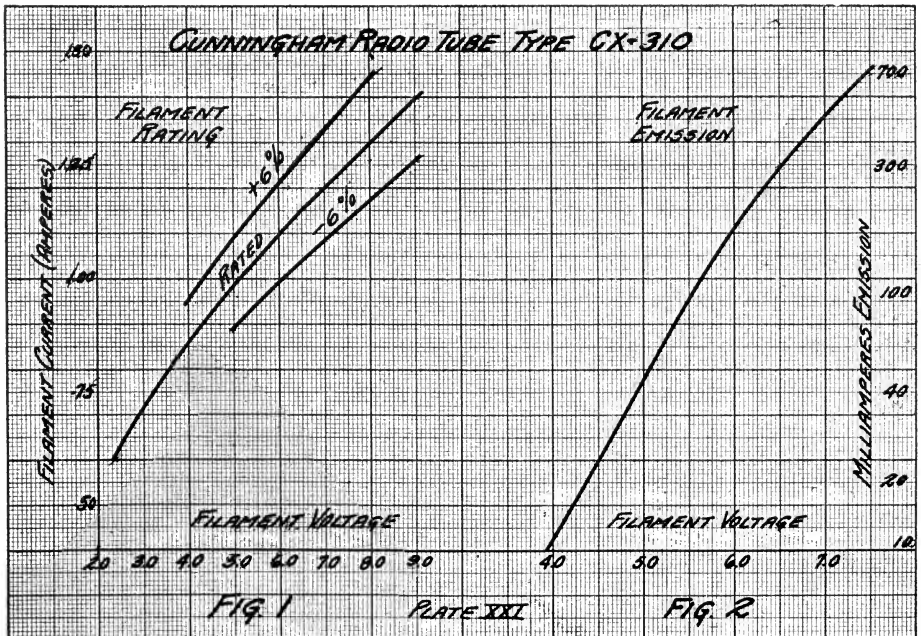
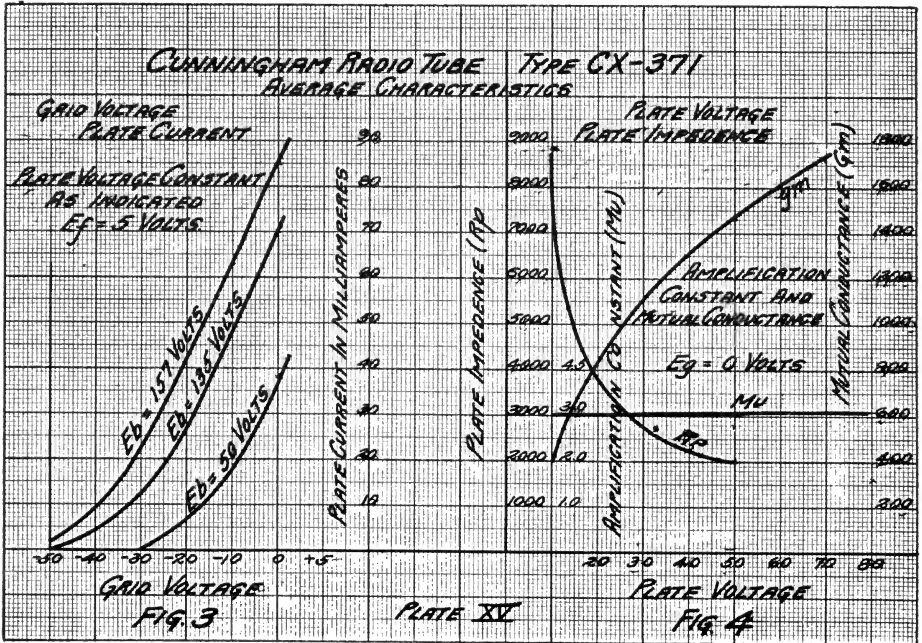

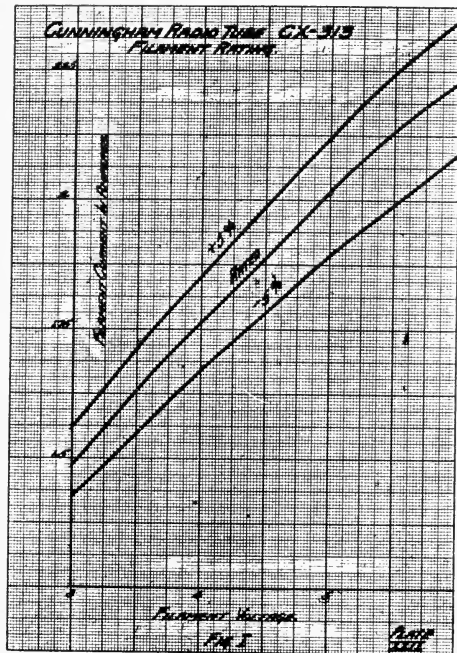
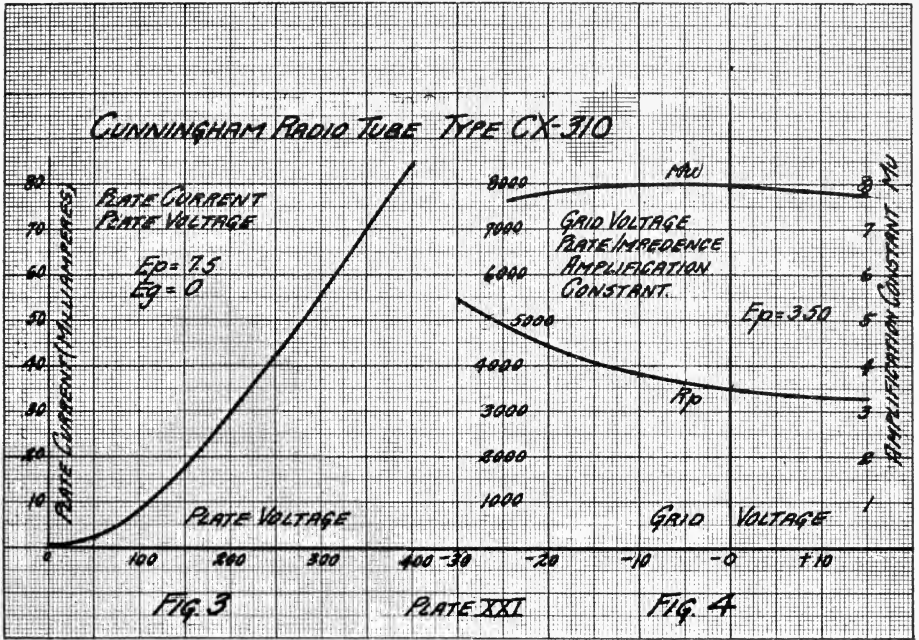

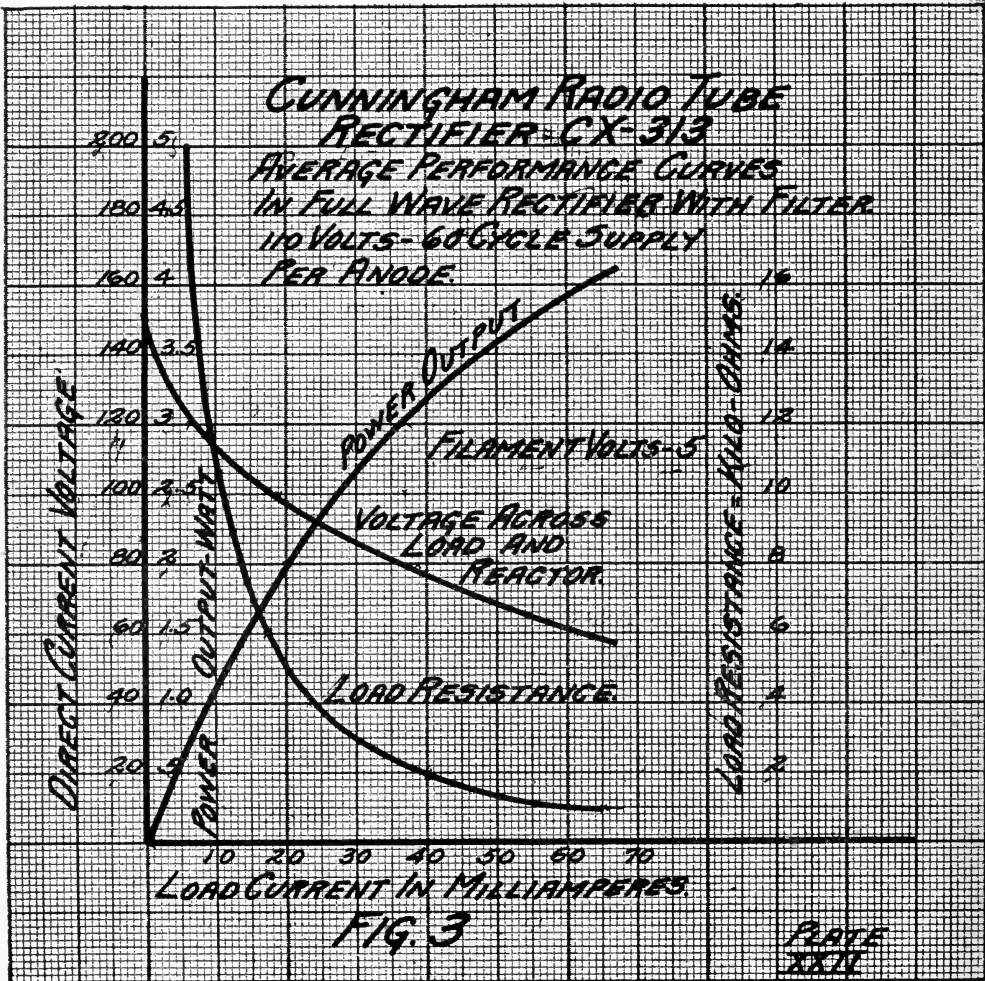

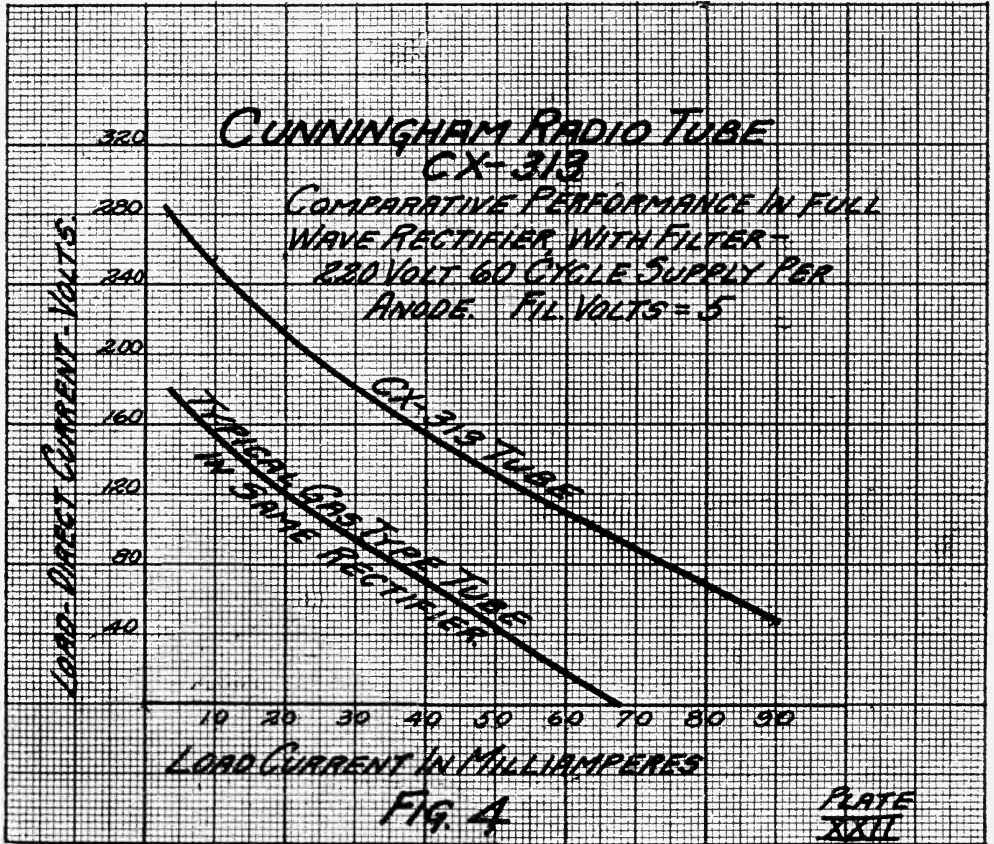

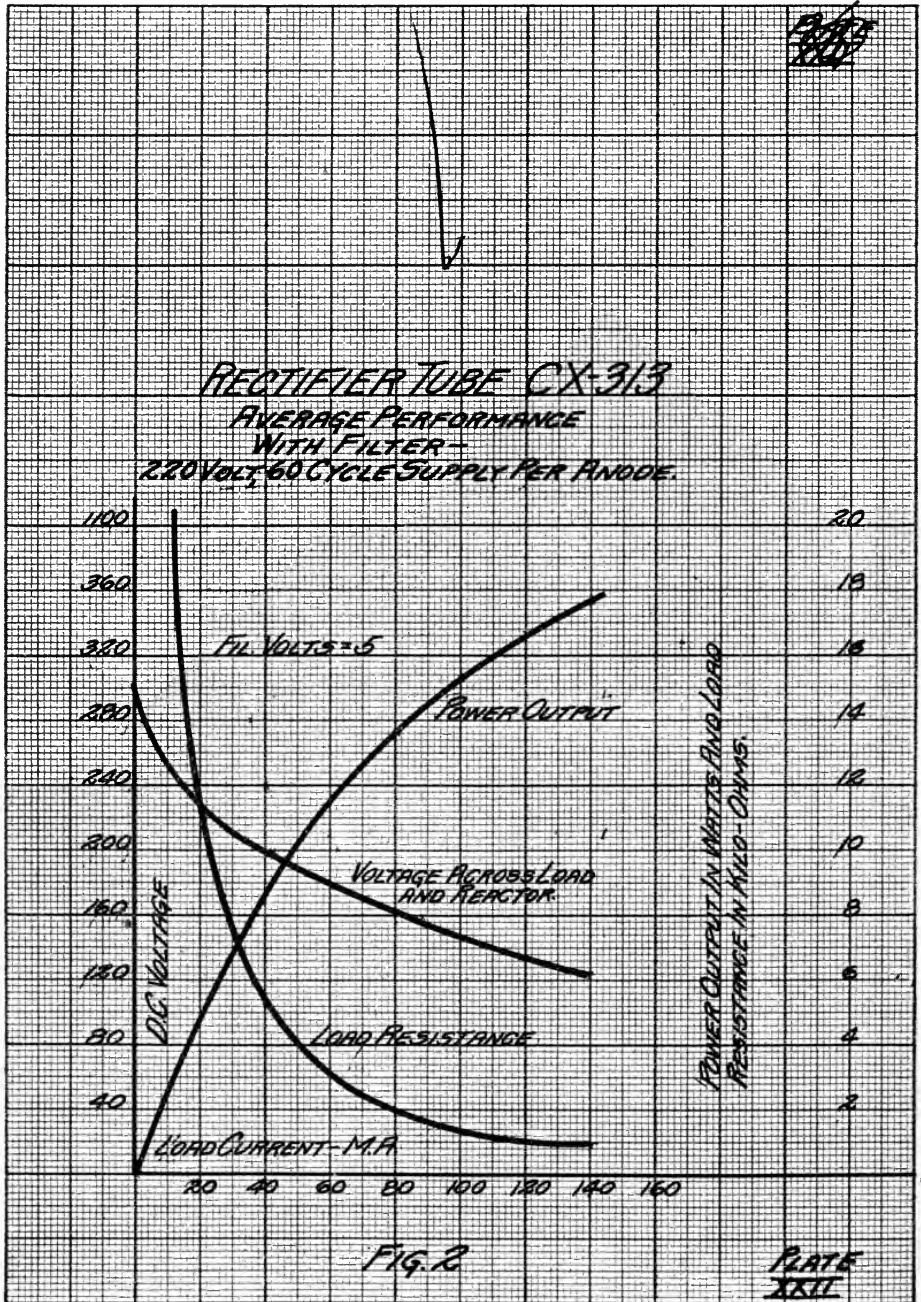

CUNNINGHAM RADIO TUBE-TYPE CX316B

FULL WAVE RECTIFIER
 USING TWO CX-216B
 TUBES. ONE TUBE
 MAY BE OMITTED FOR
 HALF WAVE OPERATION

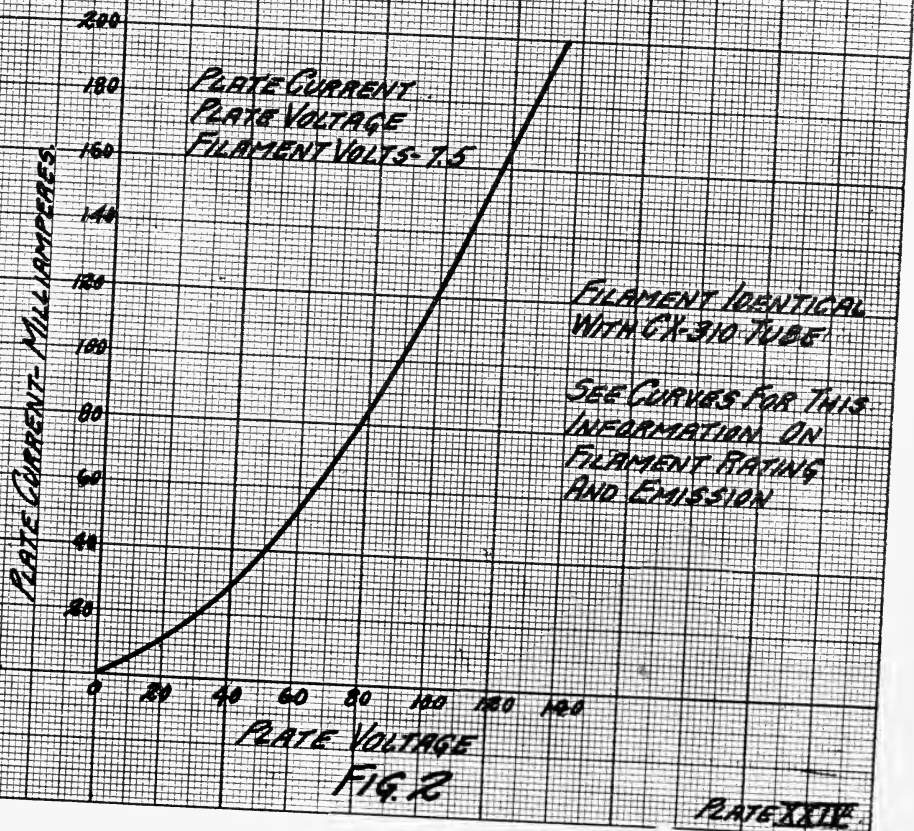
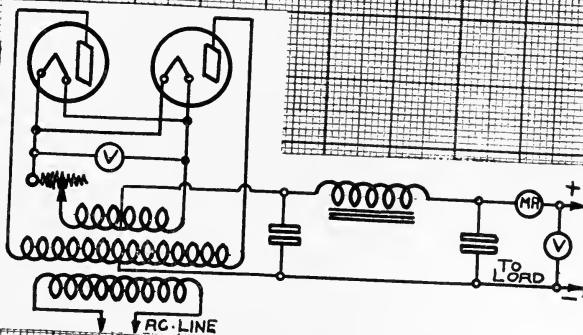

CUNNINGHAM RADIO TUBE

TYPE CX-316B in FULL
WAVE RECTIFIER WITH
FILTER: 550 VOLT-60"
SUPPLY FOR TUBE
FILAMENT VOLTS = 7.5

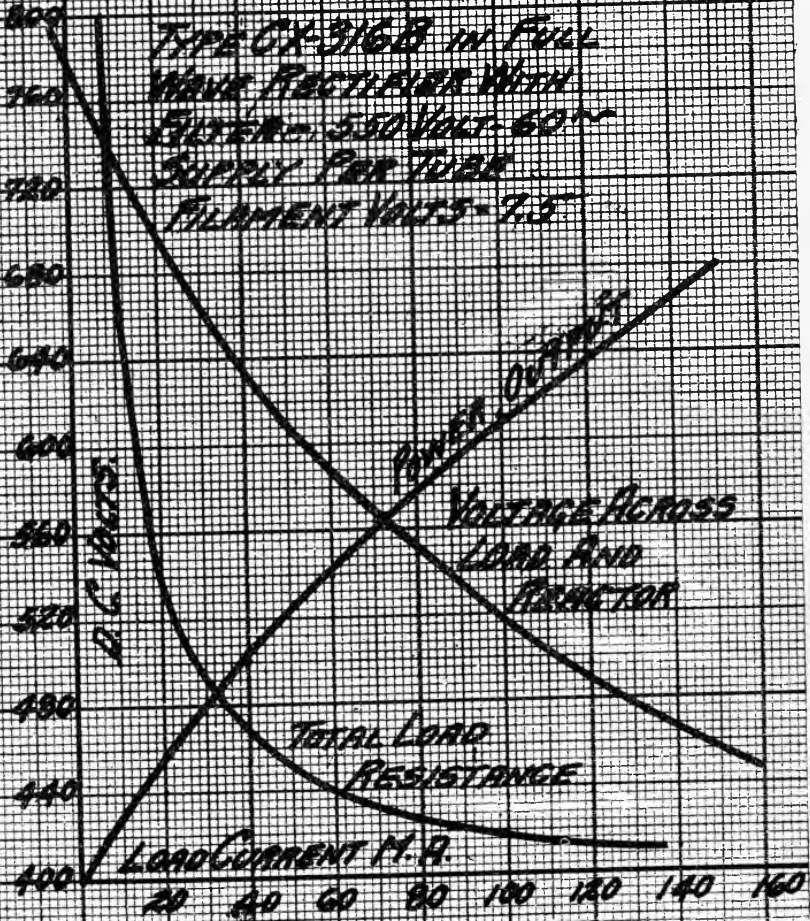

PLATE
XXIV
OR 16473

FIG. 3

**CUNNINGHAM RADIO TUBE
TYPE CX-371**

CURVES FOR COMPUTATION
OF POWER OUTPUT.

$E_p = 180$
 $E_g = 5.0$

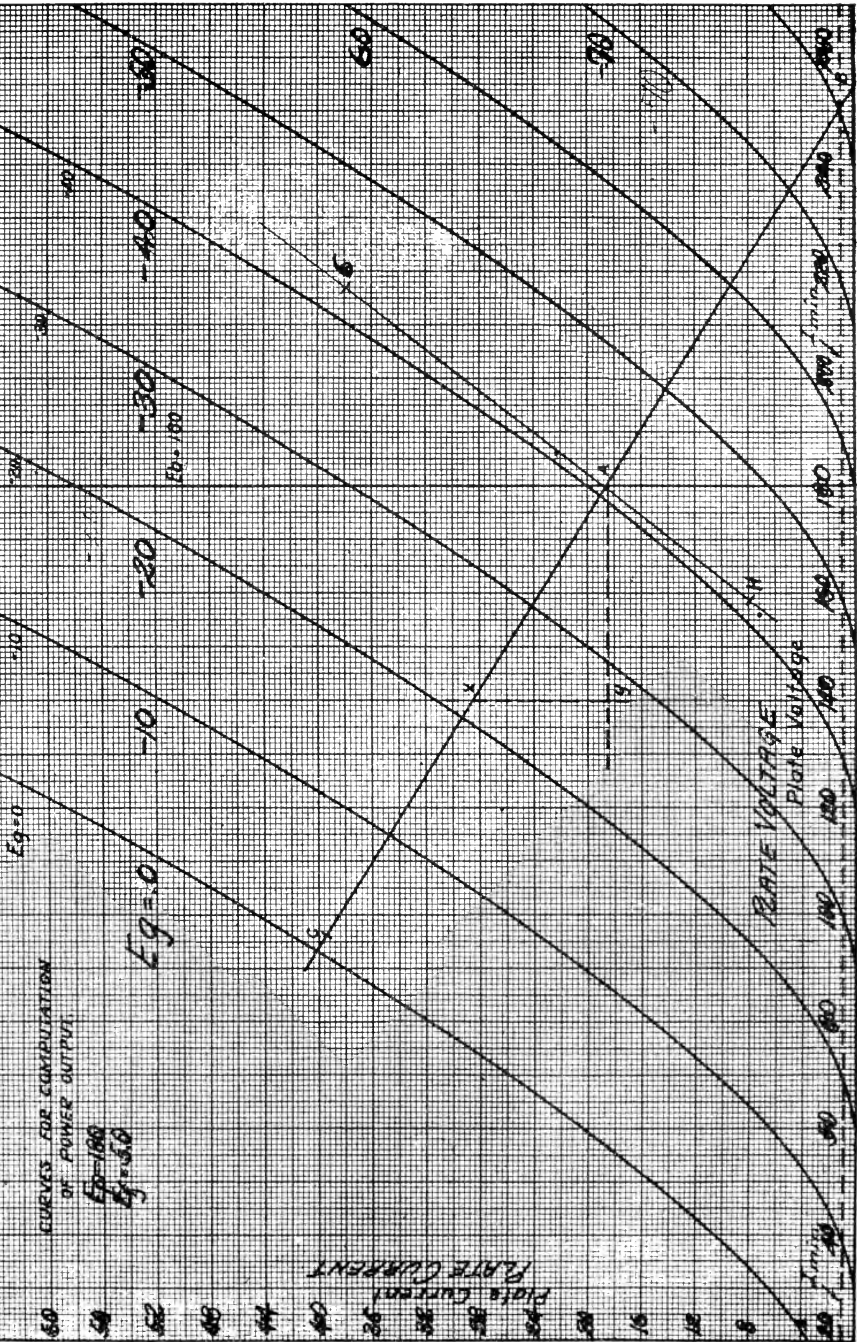

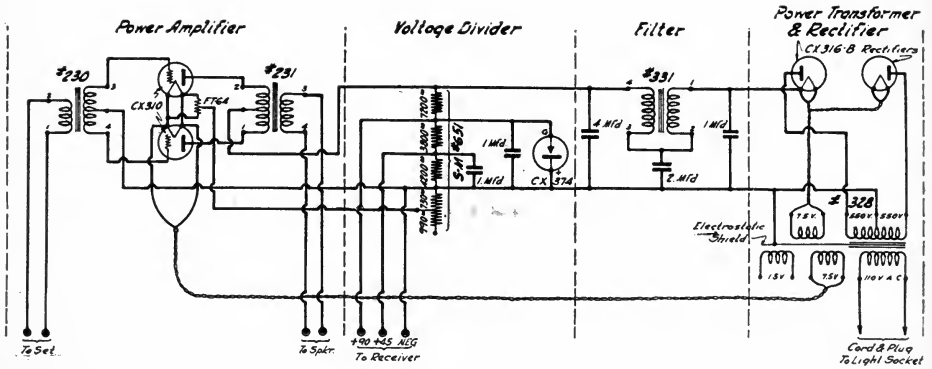

Schematic Diagram Full Wave B-C Current Supply for two UX210 Power Tubes in a Push-Pull Amplifier.

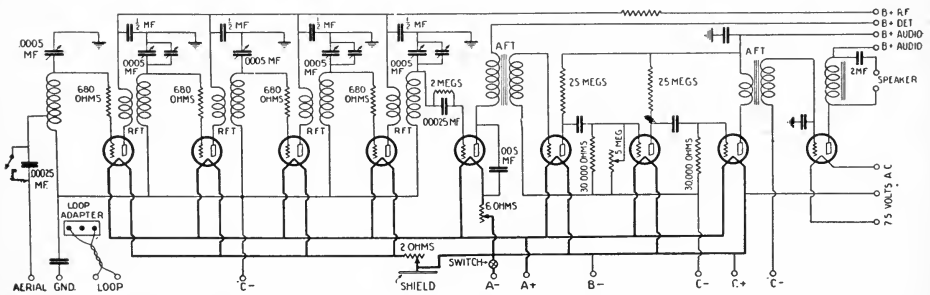

Fundamental Diagram Universal Transoceanic with special audio system used in the early models.

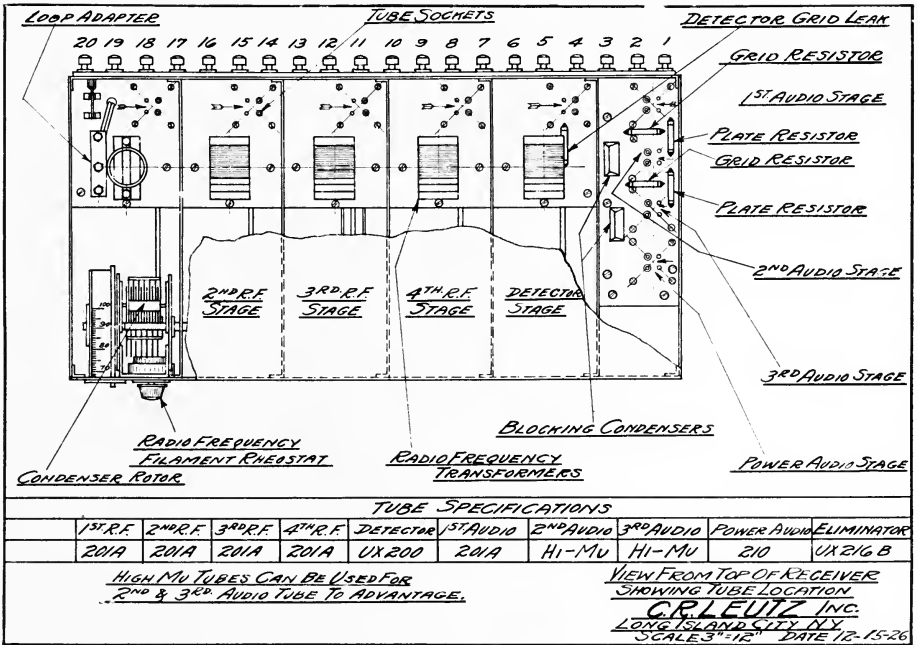

Universal Transoceanic Tube Arrangement.

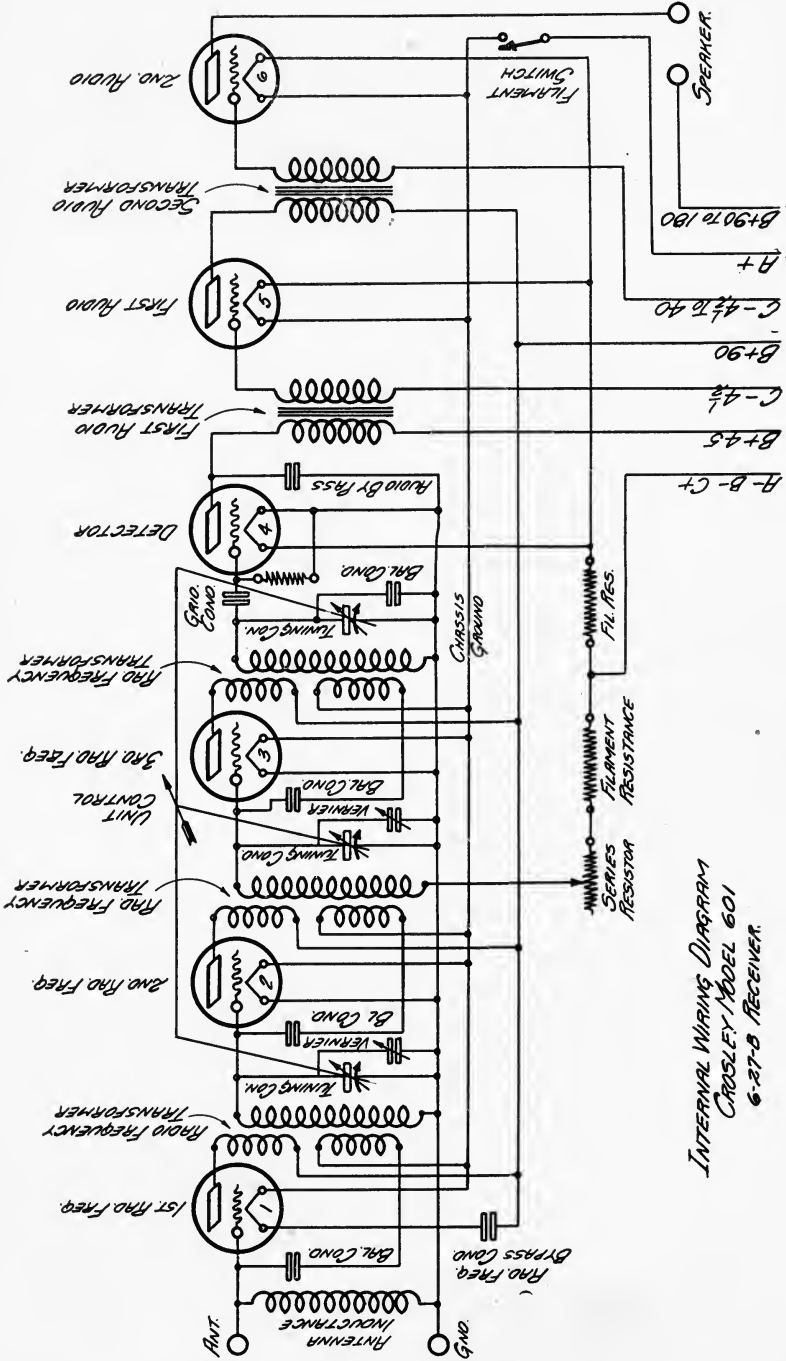

INTERNAL WIRING DIAGRAM
CROSLLEY MODEL 601
6-27-B RECEIVER

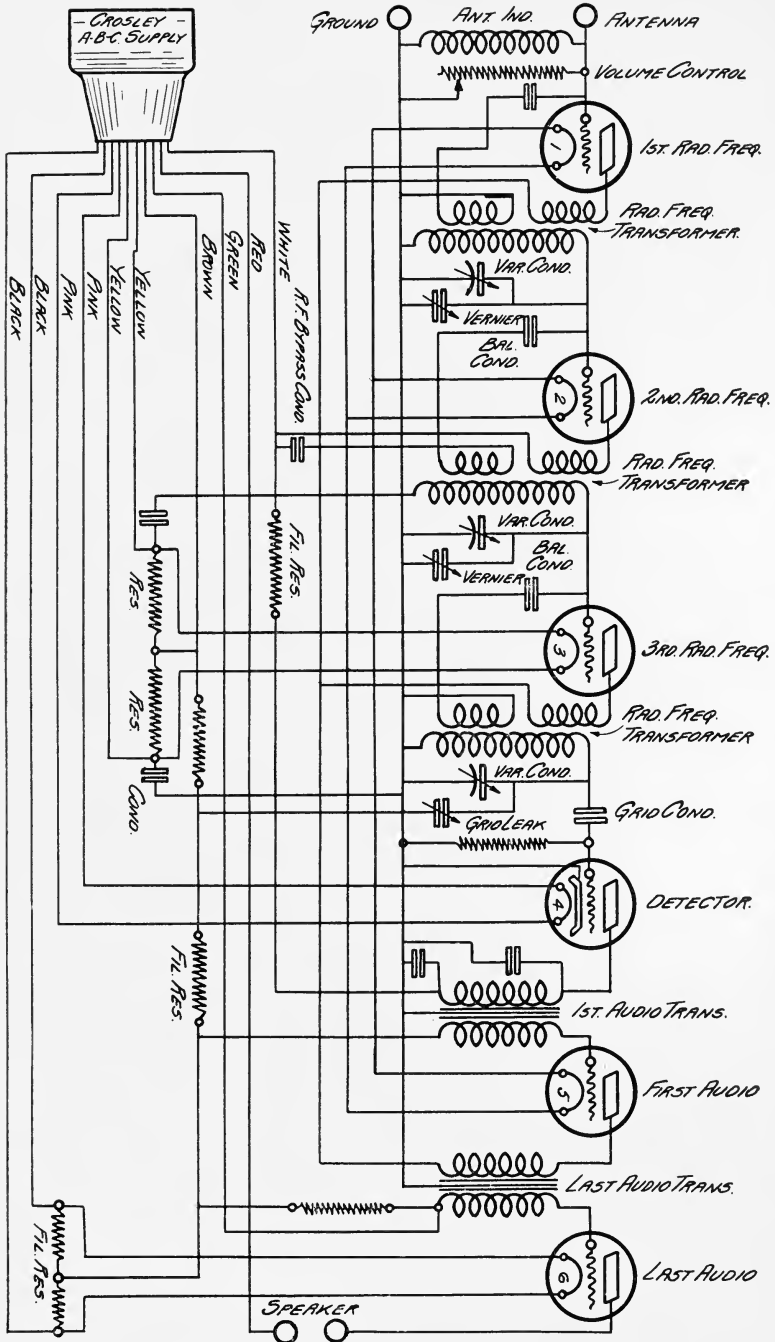

CROSLLEY A. C. RECEIVER

THE DESIGN AND USE OF THE RADIO FREQUENCY CHOKE

The amount of radio frequency amplification which can be employed successfully in the design of a broadcast receiver is very largely limited by the regenerative or "feed-back" tendency of such an amplifier. If the arrangement of the circuits is such that there exists even a small amount of inductive, capacitive, or resistance coupling between the first and succeeding stages a certain portion of the energy from the last tube may be fed back onto the grids of the previous tubes, giving rise to the phenomenon of regeneration. A limited amount of regeneration is beneficial as it effectively reduces the resistance losses of the inter-tube coupling elements. It is well known, however, that an excess of regeneration will cause the whole amplifier system to go into a state of sustained oscillation, which is fatal to its proper operation.

This tendency towards self-oscillation may be combated in a number of ways, one of the most important being the so-called process of "neutralization," whereby a certain amount of energy is fed backward through the amplifier but with a reversal of phase so that it tends to oppose the natural regeneration of the circuits. This is the principle employed in the popular neutrodyne receivers.

TYPE 379—Radio Frequency Choke

Excessive regeneration may also be prevented to a certain extent by shielding the individual stages, by controlling the grid of the amplifier tubes, or by the deliberate insertion of resistance into the individual tube circuits.

Another method of accomplishing the same result consists of more effectively separating the radio frequency circuits of the tubes from each other. The plate circuits of these tubes are almost invariably fed from the same B battery. This battery has necessarily a certain amount of resistance, depending upon its form and condition, which, being common to the plate circuits of the tubes, affords a source of resistance coupling between them if the radio frequency currents are allowed to pass through this battery. When, however, the individual plate circuits are supplied with radio frequency chokes, which prohibit the radio frequency currents from traversing the common B battery, this resistance coupling with its regenerative coupling with its regenerative tendencies can be reduced considerably.

Some of the methods for accomplishing these results are shown on the following pages. The radio frequency choke marked "379" consists merely of a small inductance coil which has a very large impedance at radio frequencies so that it effectively blocks the passage of radio frequency currents. At the same time, its resistance to the

steady emission current of the tube is low, so that but little B battery voltage is wasted across it, while its impedance at audio frequencies is sufficiently small to offer no appreciable hindrance to voice frequency currents.

Figure A shows the use of such a choke in the plate circuit of a radio frequency amplifier tube. On account of the choke the high frequency currents in the plate circuit are forced to pass through the primary of the transformer and thence through the condenser directly back to the filament of the tube, while the emission current of the tube passes through the choke to the B battery. The condenser, which offers no great impedance to the radio frequency is, of course necessary to prevent the B battery from short circuiting to the filament. Figure B shows essentially the same circuit except that here the emission current passes through the primary of the transformer.

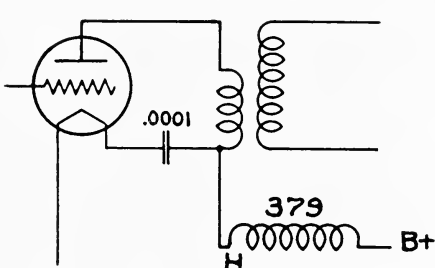

Fig. A

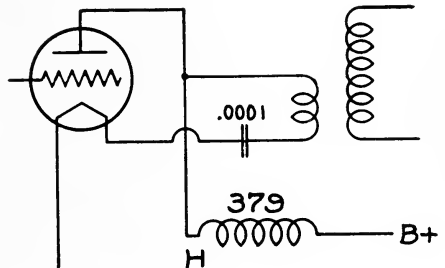

Fig. B

Figure C illustrates how the choke may be placed in the circuit of a regenerative detector to keep the radio frequency current out of the audio amplifier and the B battery. The emission current of the tube, together with the rectified audio frequency currents, pass readily through the choke to the primary of the audio frequency transformer. Regeneration of the detector is, in this case, controlled by the variable by-pass condenser in the plate circuit.

Figure D, likewise, shows the use of the choke in the plate circuit of a detector of the familiar tickler coil type.

Many other uses of a radio frequency chokes will suggest themselves to the experimenter.

The construction of a successful radio frequency choke consists of more than merely winding a coil to a sufficient inductance so that it will offer an effective barrier to radio frequency currents. The coil must also be wound in such a manner that its distributed capacity will be very low, else the capacity between the two end portions of the windings may be sufficient to pass the radio frequency currents around

the inductive impedance and defeat the whole purpose of the choke.

A radio frequency choke which, in order to reduce this capacity to a negligible amount, is wound in three-sections on a small wooden bobbin shown in the illustration below which is approximately natural size. This bobbin is then sealed into a moulded bakelite case and the coil extremities brought out to two terminal posts as shown in the illustration on the front page. The winding sections are respectively $\frac{5}{16}$, $\frac{1}{8}$ and $\frac{1}{16}$ inches in width. The end of the winding in the smallest section is brought to the terminal H, and this terminal should be connected to the "high potential" or radio frequency side of the circuits as indicated on the diagrams.

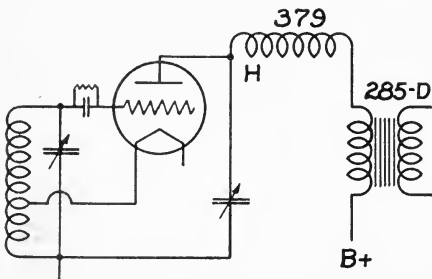

Fig. C

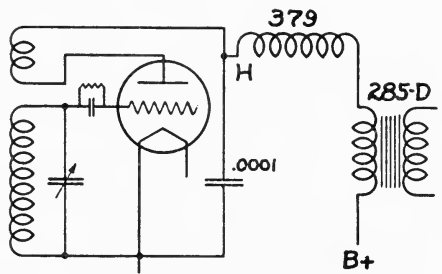

Fig. D

In order to find the best relation between inductance and distributed capacity a number of identical bobbins were wound with different sizes of wire and tested for distributed capacity in the following manner: An oscillator circuit of the Hartley type was set up as shown in Figure E. A small calibrated micro-condenser C2 of 8 MMF capacity was connected between the grid and the filament. This had a slight effect upon the tuning of the oscillator circuit. The oscillator was first accurately tuned to a given wavelength with the condenser C1 by adjusting for zero heterodyne beats against a separate crystal-controlled oscillator not shown. The choke under test was then connected between the grid and filament in parallel with C2. If now the choke coil had an effective positive capacity at the frequency in question it would, of course, raise the wavelength of the oscillator slightly. The oscillator would then be retuned to the original wavelength by reducing the variable condenser C2 by an amount equal to the effective capacity of the radio frequency choke. From the calibration of C2 the capacity of the choke could thus be measured directly. On certain occasions it was found that circuit could be retuned only by increasing the value of C2 after the choke was added, indicating that the choke had a negative capacity effect.

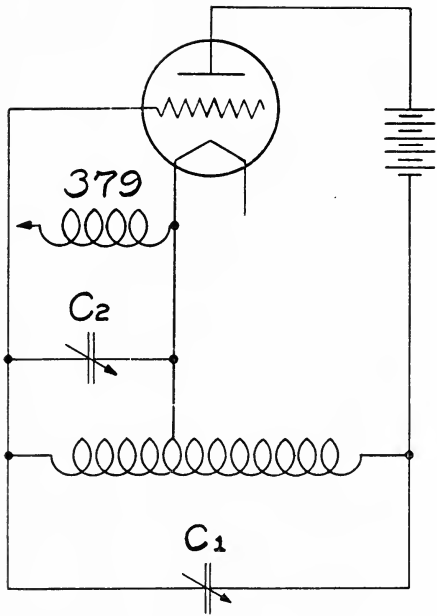
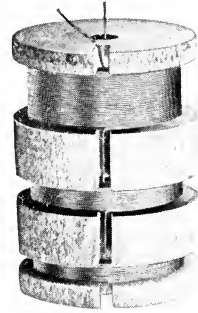

Fig. E



Radio Frequency Choke Coil

The results of these tests at various wavelengths are shown in the following table which lists the effective capacity in micro-microfarads of several samples at different wavelengths.

RADIO FREQUENCY CHOKES

Wave-length	No. 1	No. 2	No. 3	No. 4	No. 5	No. 6	No. 7	No. 8	No. 9
20	NG	3.5	NG	N.G	3.2	1.9	2.4	NG	NG
40	3.1	3.4	1.7	1.8	3.1	2.3	2.5	4.2	2.5
90	.6	2.9	3.0	3.0	3.2	-2.9	3.0	4.3	3.6
160	1.9	3.9	-6.0	-6.0	4.0	1.0	1.6	4.2	3.7
320	8.4	.6	2.9	3.1	1.0	8.8	3.7	4.0	3.6
640	-2.3	2.4	-10.8	12.0	3.5	-2.2	2.9	3.2	3.2
L=M.H	-14.5	152	7.8	7.9	153	15.3	64	92	243
	1500T	4800T	1075T	1075T	4800T	1500T	3000T		
	No.	No.	No.	No.	No.	No.	No.		
Winding	36SCC	36 En	34SCC	34SCC	36 En	36SCC	34 En		

A winding identical with No. 7 has been chosen as the General Radio R. F. choke Type 379. This has an approximate inductance of sixty millihenrys and, as seen from the table, is an effective choke for all wavelengths from twenty meters to considerably above the upper limit of the broadcast band. It may, therefore, be used to advantage in short wave receivers as well as broadcast receivers. The resistance of this instrument is about 140 ohms and its current rating 90 milli-

amperes, corresponding to a DC power rating of $1\frac{1}{8}$ watts. This current rating is for continuous use. For intermittent use, however, as for instance in a transmitter which is being keyed, the rating may be doubled with safety. The choke may, therefore, be used with success in the construction of low power amateur transmitting sets where the above ratings are not exceeded.

Realizing the demand for a radio frequency choke of higher current rating for use in amateur short wave transmitters, a lower resistance coil has been developed, wound on the same bobbin and incased in the same moulded form. The experimental data, obtained in a manner identical to that described above, are given in the following table:

Wavelength	No. 10	No. 11	No. 12
20	3	2.1	2
40	1	2.9	2.2
80	0.5	0.8	3.0
100	NG	3	0.9
160	3.4	-1.1	NG
Inductance	2.15	8.2	4.27
MH	950 T	1830 T	1340 T
Winding	No. 28 SCC	No. 32 SCC	No. 30 SCC

The winding No. 11, which further careful study showed to have no "dead spots" between 15 and 200 meters, was chosen as the standard Type 379-T choke. This type has an inductance of 8 millihenrys, a resistance of 34 ohms, a continuous current rating of 200 milliamperes, corresponding to a power rating of 1.4 watts.

DEFINITION OF THE TRANSMISSION UNIT

The use of the Transmission Unit (TU) as the proverbial “yardstick” for measuring the gain or degree of amplification in amplifiers, the loss in type of transmission circuit, or for comparing the strength of two signals, is becoming so universal that we believe a definition of this unit will be of interest to our readers.

Let us consider, for the sake of a concrete example, the case of the push-pull amplifier. In order for this instrument to function, a certain amount of alternating current power, P1, measured, if you will, in milliwatts, must be supplied to the input terminals of the amplifier. There will be, in this case, a greater amount of power P2, likewise measured in milliwatts, delivered to the loudspeaker from the output terminals of the amplifier.

The quantity $\frac{P_2}{P_1}$ is called the “Power Ratio” of the amplifier. To

express this power ratio in transmission units we make use of the relation:

$$\frac{P_2}{P_1} = 10^{\frac{n}{10}} \quad \text{or} \quad N = 10 \log \frac{P_2}{P_1}$$

That is, the number of transmission units, N, is equal to ten times the logarithm (to the base 10) of the power ratio.

A conversion table is printed below giving the relation between transmission units and the power ratio gain or loss. From this we see, for example, that an amplifier has a gain of 7.0 TU when its power ratio is 5.01, or that there is a loss of 2.6 TU in a telephone line when the power ratio of the same is 0.550, etc.

For power ratios greater than 10 or less than 0.1, we may use the same table by following the proper one of the four procedures described below:

1—Divide the power ratio gain by ten and add ten to the corresponding number of TU.

2—Multiply the power ratio loss by ten and add ten to the corresponding number of TU.

3—Subtract ten from the number of TU gain and multiply the corresponding power ratio gain by ten.

4—Subtract ten from the number of TU loss and divide the power ratio loss by ten.

TRANSMISSION UNIT CHART

NO. OF T. U.	POWER RATIO		NO. OF T. U.	POWER RATIO		NO. OF T. U.	POWER RATIO	
	GAIN	LOSS		GAIN	LOSS		GAIN	LOSS
0.1	1.023	.977	3.6	2.29	.437	7.1	5.13	.195
0.2	1.047	.955	3.7	2.34	.427	7.2	5.25	.191
0.3	1.072	.933	3.8	2.40	.417	7.3	5.37	.186
0.4	1.096	.912	3.9	2.45	.407	7.4	5.50	.182
0.5	1.122	.891	4.0	2.51	.398	7.5	5.62	.178
0.6	1.148	.871	4.1	2.57	.389	7.6	5.75	.174
0.7	1.175	.851	4.2	2.63	.380	7.7	5.89	.170
0.8	1.202	.832	4.3	2.69	.372	7.8	6.03	.166
0.9	1.230	.813	4.4	2.75	.363	7.9	6.17	.162
1.0	1.259	.794	4.5	2.82	.355	8.0	6.31	.158
1.1	1.288	.776	4.6	2.88	.347	8.1	6.45	.155
1.2	1.318	.759	4.7	2.95	.339	8.2	6.61	.151
1.3	1.349	.741	4.8	3.02	.331	8.3	6.76	.148
1.4	1.380	.724	4.9	3.09	.324	8.4	6.92	.144
1.5	1.413	.708	5.0	3.16	.316	8.5	7.08	.141
1.6	1.445	.692	5.1	3.24	.309	8.6	7.24	.138
1.7	1.479	.676	5.2	3.31	.302	8.7	7.41	.135
1.8	1.514	.661	5.3	3.39	.295	8.8	7.59	.132
1.9	1.549	.645	5.4	3.47	.288	8.9	7.76	.129
2.0	1.585	.631	5.5	3.55	.282	9.0	7.94	.126
2.1	1.622	.617	5.6	3.63	.275	9.1	8.13	.123
2.2	1.660	.603	5.7	3.72	.269	9.2	8.32	.120
2.3	1.698	.589	5.8	3.80	.263	9.3	8.51	.118
2.4	1.738	.575	5.9	3.89	.257	9.4	8.71	.115
2.5	1.778	.562	6.0	3.98	.251	9.5	8.91	.112
2.6	1.820	.550	6.1	4.07	.245	9.6	9.12	.110
2.7	1.862	.537	6.2	4.17	.240	9.7	9.33	.107
2.8	1.906	.525	6.3	4.27	.234	9.8	9.55	.105
2.9	1.950	.513	6.4	4.37	.229	9.9	9.77	.102
3.0	1.995	.501	6.5	4.47	.224	10.0	10.00	.100
3.1	2.04	.490	6.6	4.57	.219	20.0	100	.01
3.2	2.09	.479	6.7	4.68	.214	30.0	1,000	.001
3.3	2.14	.468	6.8	4.79	.209	40.0	10,000	.0001
3.4	2.19	.457	6.9	4.90	.204	50.0	100,000	.00001
3.5	2.24	.447	7.0	5.01	.200	60.0	1,000,000	.000001

Chapter V

RADIO STANDARDS AND DEFINITIONS

Standard Term—Resistor. It shall be standard that the term Resistor be used to designate devices which are used in radio apparatus circuits to introduce the element of resistance.

Standard Term—Inductor. It shall be standard that the term Inductor be used to designate devices which are used in radio apparatus circuits to introduce the element of inductance.

NOTE—This term shall be used instead of choke coil, impedance coil, inductance coil, reactance coil or retard coil.

Standard Term—Capacitor. It shall be that the term Capacitor be used to designate devices which are used in radio apparatus circuits to introduce the elements of capacitance.

Conducting Parts. Conducting parts of apparatus are those parts designed to carry current or which are conductively connected therewith.

Grounded Parts. Grounded parts of apparatus are those parts connected to ground or which may be considered to have the same potential as the earth.

Leads. Leads are insulated conductors, flexible or solid, furnished connected to a device or piece of apparatus.

Insulation. Insulation is non-conducting material used to separate parts of the same or different potentials.

Bushing (Insulating). A bushing is an insulation which insulates a through conductor from the material through which the conductor passes.

EXCEPTIONS—This term may embrace the complete unit, including conductor, support and other parts when these parts are built into such a unit.

Barrier. A barrier is a partition for the insulation or isolation of electric circuits or electric arcs.

Dielectric Tests. Dielectric tests are tests which consist of the application of a voltage higher than the rated voltage for a specified time and designed to determine the adequacy of insulating material and spacing.

Contact. A contact is a surface common to two conducting parts, united by pressure for the purpose of carrying current.

Break. The break of a circuit opening device is the minimum distance between the stationary and movable contacts when these contacts are in the open position.

(a) The length of a single break is as defined above.

(b) The length of a double break (breaks in series) is the sum of two breaks.

(c) The length of a quadruple break (breaks in series) is the sum of the four breaks.

Switch. A switch is a device for making, breaking or changing the connections in an electric circuit.

Relay. A relay is a device which is operative by a variation in the characteristics of one electric circuit to effect the operation of other devices in the same or another electric circuit.

Connection Diagram. A connection diagram is a diagram showing the relations and connections of devices and apparatus of a circuit or group of circuits.

Radio Communication. The transmission of signals by means of radiated electromagnetic waves originating in a constructed circuit.

Broadcasting. The transmission of music, news, entertainment or intelligence intended for general reception.

Signal. The intelligence, message, or effect conveyed in communication.

Radio Field Intensity. The root-mean-square value of the electric or magnetic field intensity at a point due to the passage of radio waves. It is often expressed in micro-volts per meter.

Radio Noise Field Intensity. A measure of the field intensity, at a point (as a radio receiving station), of electro-magnetic waves of an interfering character. In practice the quantity measured is not the field intensity of the interfering waves, but some quantity which is proportional to or bears a known relation to the field intensity.

Signal-Noise Ratio. The ratio at a point of the field intensity of the radio wave to the radio noise field intensity.

Strays. Electromagnetic disturbances in radio reception other than those produced by radio transmitting systems.

Static. Conduction or charging current in an antenna resulting from physical contact between the antenna and charged bodies or masses of gas.

NOTE—In the United States this term has come to be used quite generally as a synonym for atmospheric.

Atmospherics. Strays produced by atmospheric conditions.

WAVES

Wave. (a) A propagated disturbance, usually periodic; as, an electric wave or a sound wave.

(b) A single cycle of such a disturbance.

(c) A periodic variation as represented by a graph.

Wavelength. The distance traveled in one period or cycle by a periodic disturbance. The distance between corresponding phases of two consecutive waves of a wave train. The quotient of velocity by frequency.

Continuous Waves. Alternating electric waves in space, of constant amplitude and frequency. (Abbreviation—cw.)

Modulated Continuous Waves. Continuous waves of which the amplitude or frequency is repeatedly varied in accordance with a signal wave.

Key-Modulated Continuous Waves. Continuous waves of which the amplitude or frequency is varied by the operation of a transmitting key in accordance with the characters of a communicating code.

Interrupted Continuous Waves. Waves obtained by the interruption at audio frequency in a periodic manner of an otherwise continuous wave (Abbreviation—i.c.w.)

Damped Waves. Electromagnetic waves proceeding in wave trains in each of which the amplitude progressively diminishes in successive cycles.

Signal Wave. A wave, the form of which conveys a signal.

Carrier Wave. The component of a modulated wave which has the same frequency as the original unmodulated wave.

ELECTRIC CURRENTS

Alternating Current. A current, the direction of which reverses at regularly recurring intervals, the algebraic average value being below zero.

Damped Alternating Current. A current passing through successive cycles with progressively diminishing amplitude.

Free Alternating Current. The damped alternating current which flows in a circuit following the cessation of an impressed voltage.

Forced Alternating Current. The alternating current which flows in a circuit as the result of an impressed alternating voltage and which has the same frequency.

Pulsating Current. A periodic current (that is, current passing through successive cycle), the algebraic average value of which is not zero. A pulsating current and a constant amplitude direct current.

Direct Current. A unidirectional current. As ordinarily used, the term designates a practically non-pulsating current.

Periodic Current. Periodically reversing current the frequency of which is determined by the electrical constants of the circuits in which it flows. It may either damped or continuous.

Oscillatory Circuit. A relatively low resistance circuit containing both inductance and capacity, such that a voltage impulse will produce a current which periodically reverses.

FREQUENCY

Cycle. One complete set of positive and negative values of an alternating current.

Frequency. The number of cycles per second.

Kilocycle. (Strictly kilocycle per second or cycle per millisecond).
—A thousand cycles per second.

Megacycle. (Strictly megacycle per second or cycle per microsecond.)—A million cycles per second.

Audio Frequencies. The frequencies corresponding to normally audible sound waves. The upper limit ordinarily lies between 10,000 and 20,000 cycles.

Radio Frequencies. The frequencies higher than those corresponding to normally audible sound waves.

NOTE—It is not implied that radiation cannot be secured at lower frequencies, nor that radio frequencies are necessarily above the limit of audibility.

Group Frequency. The number of trains damped waves or current per second.

NOTE—The terms “group frequency” has replaced the term “spark frequency.”

Resonance Frequency (of a Circuit). The frequency at which the supply current and supply voltage of the circuit are in phase.

Fundamental Frequency. That frequency of which all component frequencies are integral multiples.

Fundamental Wavelength. The wavelength corresponding to fundamental frequency.

Harmonic. A component of a periodic quantity having a frequency which is an integral multiple of the fundamental wave frequency. For example, a component, the frequency of which is twice the fundamental frequency, is called the second harmonic.

Beating. A phenomenon in which two or more periodic quantities of not greatly different frequencies react with each other to produce a resultant having pulsations of amplitude.

Beat. A complete cycle of such pulsations.

Beat Frequency. The number of beats per unit of time. This frequency is equal to the difference between the frequencies of the combining waves.

COUPLING

Coupling. The association of two circuits in such a way that energy may be transferred from one to the other.

Coupling Coefficient. The ratio of the mutual or common impedance component of two circuits to the square root of the product of the total impedance components of the same kind in the two circuits. (Impedance components may consist of inductance, capacity or resistance.)

Direct Coupling. Association of two radio circuits by having an inductor, a capacitor, or a resistor, common to both circuits.

Inductive Coupling. The association of one circuit with another by means of inductance common or mutual to both. (This term when used without modifying words is commonly used for coupling by means of self-inductance common to both circuits is called "direct inductive coupling.")

Capacity Coupling. The association of one circuit with another by means of capacity common or mutual to both.

Resistance Coupling. The association of one circuit with another by means of resistance common to both.

Coupler. An apparatus which is used to transfer radio-frequency power from one circuit to another by associating together portions of these circuits. Couplers are of the same types as the types of coupling—inductive, capacity, and resistance.

Coupling Inductor. An inductor used as a coupler.

Coupling Capacitor. A capacitor used to produce coupling two circuits.

FILTERS

Filter. A selective circuit network designed to transmit alternating-currents within a continuous band or bands of frequencies and attenuate currents of all frequencies outside the transmission band or bands.

Low-Pass Filter. A filter designed to transmit currents of all frequencies below a critical or cut-off frequency and attenuate currents of all frequencies above this critical frequency.

High-Pass Filter. A filter designed to transmit currents of all frequencies above a critical or cut-off frequency and attenuate currents of all frequencies below this critical frequency.

Band-Pass Filter. A filter designed to transmit currents of frequencies within a continuous band limited by an upper and a lower critical or cut-off frequency and attenuate currents of all frequencies outside of that band.

Acceptor. A circuit having inductance and capacity so arranged and tuned as to offer low impedance to currents of a given frequency, and high impedance to currents of any other frequency.

Rejector. A circuit having inductance and capacity so arranged and tuned as to offer high impedance to the flow of currents of a given frequency and low impedance to currents of all other frequencies.

Amplifier. A device for increasing the amplitude of electric current or voltage, through the control by the input power of a larger amount of power supplied by a local source to the output circuit.

Power amplifier. An amplifier which is capable of producing relatively large power in an output circuit.

Voltage Amplification. The ratio of the alternating voltage produced at the output terminals of an amplifier to the alternating voltage impressed at the input terminals. (This term should not be used to describe a process).

Current Amplification (of an Amplifier). The ratio of the alternating current produced in the output circuit to the alternating current supplied to the input circuit.

Power Amplification (of an amplifier). The ratio of the alternating-current produced in the output circuit to the alternating-current power supplied to the input circuit.

Series Resonance. A condition which exists in a circuits having inductance and capacity connected in series, when the supply current and supply voltage are in phase.

Parallel Resonance. A condition which exists in a circuit having inductance and capacity connected in parallel, when the supply current and supply voltage are in phase.

Rectifier. A device whose resistance for currents in one direction differs from its resistance for currents in the othen direction and which is used to convert an alternating-current wave into a unidirectional wave.

NOTE—In dealing with rectification in the reception of radio signals the term “detector” or “converter” is preferred to “rectifier.”

Half-Wave Rectifier. A rectifier which changes alternating current into pulsating, unidirectional current, utilizing only one-half of each cycle.

Full-Wave Rectifier. A double rectifier arranged so that current is allowed to pass in the same direction to the load circuit during each half cycle of the alternating-current supply, one element functioning during one-half cycle and the other during the next half cycle, and so on.

Vacuum Tube Rectifier. A device for rectifying an alternating-current by utilizing the electron flow between two electrodes in a vacuum or in a gas.

Attenuation Equalizer. A device for altering the attenuation of a circuit for various frequencies in order to make substantially equal the total attenuation for all frequencies within a certain range.

Transmission Level. The radio field intensity or the signaling power amplitude at any point in a communication system, expressed either in some absolute unit or with reference to an arbitrary base value.

Transmission Unit (Abbreviation TU). A unit of power ratio used for expressing transmission loss or transmission gain (amplification.) Two amounts of power differ by one transmission unit when they are

in ratio of $10^{0.1}$. Two amounts of power differ by N transmission units when they are in the ratio of $10^{(0.1) N}$. The number of transmission units is ten times the common logarithm of the power ratio to be expressed: i.e.,

$$10 \log \frac{P_1}{P_2}$$

Power Ratio	TU
1 (=10 ⁰)	0 (=10 log ₁₀ 1)
1.259 (=10 ^{0.1})	1 (=10 log ₁₀ 1.259)
10 (=10 ¹)	10 (=10 log ₁₀ 10)
100 (=10 ²)	20 (=10 log ₁₀ 100)
1000 (=10 ³)	30 (=10 log ₁₀ 1000)

For current ratios, the number of transmission units is equal to 20 times the common logarithm of the current ratio (with constant im-

pedance) to be expressed; i.e., $20 \log \frac{I_1}{I_2}$

Current Ratio	TU
0.001	-60.00
0.005	-46.02
0.01	-40.00
0.05	-26.02
0.1	-20.00
0.2	-13.98
0.5	-6.02
1.0	0.00
1.5	3.52
2	6.02
5	13.98
10	20.00
20	26.02
50	33.98
100	40.00
500	53.98
1000	60.00

Transmission-Frequency Characteristic. The variation with frequency of the transmission efficiency of a circuit or transmission path.

Distortion. A change in wave form as in passing through a circuit or transmission medium. A wave form may be distorted by:

- (a) The presence in the output of components having frequencies not present in the original wave due to circuit elements having non-linear characteristics.

- (b) A change in the relative amplitude of the component frequencies due to variation in the transmission efficiency over the frequency range involved.
- (c) A change in the relative phase of the component frequencies. (Not a cause of distortion when present in audio-frequency waves.) Two or more of these forms of distortion may exist simultaneously.

Transmission Loss. The loss of power suffered by a transmission wave in passing along a transmission path or through a circuit device.

TRANSFORMERS

Radio Frequency Transformer. A transformer for use with radio-frequency currents.

Audio-Frequency Transformer. A transformer for use with audio-frequency currents.

Resonance Transformer. A transformer with capacitor load, whose circuits are adjusted as a whole to have the same frequency as that of the alternating current supplied to the primary, thereby causing the secondary voltage to build up to higher values than would otherwise be attained.

METERS

Frequency Meter. An instrument for measuring frequency. (Frequency meters used in radio work are sometimes called wavemeters.)

Hot-Wire Ammeter (Expansion Type). An ammeter depending for its indications on a change in dimensions of an element which is heated by a current through it.

Thermocoupler Ammeter. An ammeter depending for its indications on the change in thermo-electromotive force set up in a thermo-electric couple which is heated by the current to be measured.

Vacuum Tube Voltmeter. A device for measuring small voltages consisting of a vacuum tube having an ammeter in its output circuit. These scale deflections are calibrated in terms of the voltage applied to the grid circuit.

MISCELLANEOUS

"A" Battery. A battery which provides heating current for the filament of a vacuum tube.

"B" Battery. A battery connected in the plate circuit of a vacuum tube, for the purpose of supplying power to the plate circuit.

"C" Battery. A battery connected in the circuit between the filament and grid of a vacuum tube so as to apply a potential to the grid.

Rheostat. A resistor which is provided with means for readily varying its resistance.

Potentiometer. A device consisting of a resistor provided with a

movable or sliding contact in addition to its terminal contacts. It is used as a voltage divider. The current is passed between the terminal contacts and the desired difference of potential is obtained between one terminal contact and the movable contact. ("Voltage divider" is a preferred term.)

Protective Device. A device for keeping currents or voltages of undesirably large magnitude out of a given part of an electrical circuit. For example, fuse, lightning arrestor.

By-Pass Capacitor. A capacitor used to provide a path of comparatively low impedance around some circuit element.

Stopping Capacitor. A capacitor used to insert a comparatively high impedance in some branch of a circuit for the purpose of limiting the flow of low frequency alternating current or direct current without materially affecting the flow of high frequency alternating current.

Loading Inductor. An inductor, usually not inductively coupled to any other circuit, for connection in a tuned circuit to decrease its resonant frequency.

Banked Winding. A form of coil winding in which single turns are wound successively in each of two or more layers, the winding proceeding from one end of the coil to the other, without return.

Regeneration. The process by which a part of the output power of an amplifying device acts upon the input circuit in such a manner as to reinforce the initial power, thereby increasing the amplification. (Sometimes called "feed back.")

Radio Channel. A band of frequencies or wave lengths of a width sufficient to permit of its use for radio communication. The width of a channel depends upon the type of transmission.

Radiate. To emit electromagnetic waves into space.

Radiation. The process of emitting electro magnetic waves into space.

Carrier Current. An alternating current which is modulated by a signal. Ordinarily refers to wire transmission of high-frequency currents.

Carrier Frequency. Frequency of a carrier wave or a carrier current.

Carrier Suppression. That method of operation in which the carrier wave or carrier current is not transmitted.

Band of Frequencies. A continuous range of frequencies extending between two definite frequencies.

Side Bands. The bands of frequencies, one on either side of the carrier frequency, produced by the process of modulation.

Side Frequencies. The frequency on either side of the carrier frequency produced by the process of single frequency modulation.

Single-Side-Band Transmission. That method of operation in which one side band is transmitted, and the other side band is suppressed.

The carrier wave may be either transmitted or suppressed.

Atmospheric Absorption. A loss of power in transmission of radio waves due to a dissipation in the atmosphere.

Radio Transmitting Set (Transmitter). A device for producing radio-frequency power and modifying it in accordance with a signal.

Vacuum Tube Transmitter. A radio transmitter in which vacuum tubes are utilized to convert the applied electric power into radio-frequency power.

Alternator Transmitter. A radio transmitter which utilizes radio-frequency currents generated by a radio-frequency alternator.

Radio-Frequency Alternator. A rotating-type alternating-current generator which generates radio frequency currents.

Spark Transmitter. A radio transmitter which utilizes the oscillatory discharge of a capacitor through an inductor and a spark gap as the source of its radio-frequency power.

Plain Antenna Transmitter. A spark transmitter in which the spark gap is connected directly in the antenna circuit.

Oscillator. A non-rotating device for producing alternating current, the output frequency of which is determined by the characteristics of the device.

Master Oscillator. An oscillator of comparatively low power so arranged as to control the frequency of the output of an amplifier.

Spark Gap. An arrangement of electrodes, used for closing a circuit (usually oscillatory) at a predetermined voltage. The several types of spark gaps are:

- (a) Plain Gap—A spark gap between two fixed metal electrodes.
- (b) Rotary Gap—Spark gap in which one of the electrodes is a rotating element which causes a regular change in gap length thereby timing the beginning of the discharge and modifying its duration.
- (c) Synchronous Rotary Gap—A rotary gap in which the speed of rotation is such that the discharge is synchronous with the alternating voltage applied.
- (d) Quenched Gap—A spark gap in which the strongly damped discharge current is quickly stopped by the quenching or extinction of the spark.

Arc Converter. A form of oscillator comprising an electric arc used for the conversion of direct to alternating or pulsating current.

Load Compensator. Part of a radio-frequency alternator speed regulator consisting of a device to vary the torque of the motor driving a radio-frequency alternator approximately in accordance with variations of the load on the motor.

Impulse Excitation. A method of producing damped oscillatory current in a circuit in which the duration of the impressed voltage is short compared with the duration of the current produced.

Frequency Changer. A device delivering alternating current at a frequency which differs from the frequency of the supply current.

Frequency Multiplier. A frequency changer used to multiply by an integer the frequency of an alternating current.

Modulation. The process whereby the frequency or amplitude of a wave is varied in accordance with a signal wave.

Double Modulation. The process of modulation in which a carrier wave of one frequency is first modulated by the signal wave and is then made to modulate a second carrier wave of another frequency.

Percentage Modulation. The variation in amplitude of a modulated wave from its mean value expressed in per cent. of the mean value.

Modulator. A device to effect the process of modulation. It may be operated by virtue of some non-linear characteristic or by a controlled variation of some circuit quantity.

Magnetic Modulator (Ferromagnetic Modulator). A magnetic device employed as a modulator and functioning by virtue of its non-linear magnetization characteristic.

Vacuum Tube Modulator. A modulator employing a vacuum tube as a modulator element.

Monitoring Receiver. A receiver arranged to enable an operator to check the operation of a transmitting set.

Logarithmic Decrement. The Napierian logarithm of the ratio of the first to the second of two successive amplitudes in the same direction, for an exponentially damped alternating current. The logarithmic decrement can also be considered as a constant of a simple radio circuit, being x times the product of the resistance by the square root of the ratio of the capacity to the inductance of the circuit.

Decremeter. An instrument for measuring the logarithmic decrement of a train of waves.

Damping Constant. The Napierian logarithm of the ratio of two values of an exponentially decreasing quantity separated by unit time. (This is referred to the term "damping factor.")

The coefficient " a " appearing in the exponent of the damping factor, which occurs in expressions of the following forms for damped currents.

In an oscillatory circuit containing resistance, inductance, and capacity in series, $a = R/2L$.

Tank Circuit. An intermediate oscillatory circuit associated with the output circuit of a vacuum tube transmitter which absorbs the output

of the vacuum tube transmitter in the form of energy impulses of high value and short duration and power to the load in substantially sinusoidal form.

Duplex Operation. The operation of associated radio transmitting and radio receiving channels in which transmission and reception are simultaneous.

Direction Finder (Radio Compass or Goniometer). A radio receiving device which permits determination of the line of travel of waves as received from transmitting station.

Direction Finder Calibration. The determination of the direction and amount of local wave front distortion to the end that the true bearing may be determined from the apparent bearing given by the direction finder.

Radio Wave Front Distortion. A change in the direction of advance of radio waves.

Unidirectional Radio direction Finder (Sense Radio Direction Finder. A radio receiving device which permits determination of the direction (without 180° ambiguity) of waves as received from a transmitting station.

Radio Beacon. A radio transmitting station in a fixed geographic location which emits a distinctive or characteristic signal for enabling mobile receiving stations to determine bearings.

Equisignal Radio Beacon. A radio beacon which transmits two distinctive signals which may be received with equal intensity only in certain directions.

Equisignal Zone. The region in which the two distinctive signals from an equisignal radio beacon are received with equal intensity.

Observed Radio Bearing. The angular deviation from an arbitrary fixed line, such as the earth's geographical meridian of the incoming wave as determined by a radio direction finder (without calibration correction).

Correct Radio Bearing. An observed radio bearing to which the calibration correction has been applied.

True Radio Bearing. The angular deviation from true North, at the point of observation, of the chord of the great circle passing from the observer, to a given transmitting station.

Fix. The intersection of the lines of direction of two or more bearings.

Balancing Capacitor. A capacitor used for equalizing the potentials at the terminals of a direction finder coil when set in the position of minimum signal.

Antenna. A device for radiating or absorbing radio waves.

Aerial. The elevated conductor portion of a condenser antenna.

Beam Antenna. A unilateral directive antenna such that its radiation is substantially confined to a narrow beam.

Unilateral Antenna. An antenna having the property of radiating or receiving radio waves in larger proportion in some one angular regions 180 degrees apart than in all other directions.

Cage Antenna. An antenna having conductors which consist of groups of parallel wires arranged as the elements of a cylinder.

Coil Antenna. An antenna consisting of one or more complete turns of wire.

Capacity Antenna. An antenna consisting of two capacity areas.

Directive Antenna. An antenna having the property of radiating radio waves in larger proportion along some directions than others.

Directional Antenna. An antenna having the property of radiating or receiving radio waves in larger proportion along some directions than others.

Flat Top Antenna. An antenna having approximately horizontal conductors at the top.

Harp Antenna. An antenna composed of vertical, or approximately vertical conductors, all in one plane.

Inverted "L" Antenna. A flat top antenna in which the lead-in is taken from one end of the horizontal portion.

Multiple Tuned Antenna. An antenna with connections to ground through inductances at more than one point, the inductances being so determined that their reactances in parallel present a total reactance equal to that necessary to give the antenna the desired natural frequency.

Feed Ratio (of a multiple tuned antenna). The value obtained by dividing the sum of the currents at all the antinodes by the current in the line feeding the antenna.

Series or Feed Resistances (of multiple tuned antenna). The quotient of the power delivered to the antenna by the square of the current in the line feeding the antenna.

"T" Antenna. A flat top antenna in which the lead-in is taken from the center of the horizontal portion.

Umbrella Antenna. An antenna, the conductors of which form elements of a cone with the apex at the top to which the lead-in is connected.

Wave Antenna. A horizontal aerial the physical length of which is of the same order of magnitude as that of the signaling waves to be received, and which is so used as to be strongly directional.

Antenna Resistance. An effective resistance which is numerically equal to the quotient of the average power in the entire antenna circuit

by the square of the effective current at the point of maximum current.

NOTE—Antenna resistance includes: Radiation resistance, ground resistance, radio-frequency resistance of conductors in antenna circuit, equivalent resistance due to corona, eddy currents, insulator leakage, dielectric loss, and so on.

Effective Height of an Antenna. The height of an equivalent ideal antenna producing the same radiated field. As ordinarily defined, this ideal antenna is a vertical conductor carrying a uniform current equal to the maximum current existing at any point in the actual antenna.

Meter Amperes. The product of the antenna current in amperes at the point of maximum current and of the antenna effective height in meters for any radio transmitting station. It constitutes a factor for indicating the radiating strength of radio transmitting stations.

Ground Systems (of an antenna). The portion of the antenna system below the antenna loading devices or generating apparatus most closely associated with the ground and including the ground itself.

Ground Wire. A conductive connection to the earth.

Ground Equalizer Inductors. Coils of relatively low inductance placed in the circuit connected to one or more of the grounding points on an antenna ground system, to divide the current between the various points in any desired way.

Antenna Form Factor. The ratio of the effective height of an antenna to its actual physical height.

Radiation Resistance. The quotient of the total power radiated by an antenna by the square of the effective current at the point of maximum current.

Radiation Efficiency. The radiation efficiency of an antenna is the ratio of power radiated to the total power delivered to the antenna, at a given frequency.

Fundamental or Natural Frequency (of an Antenna). The lowest resonant frequency of an unloaded antenna. (Unloaded, i.e., without added inductance or capacity.)

Lead-In. That portion of an antenna system which completes the electrical connection between the elevated outdoor portion and the instruments or disconnecting switches inside the building.

Antenna Loading Inductor. An inductor, inserted to increase the inductance of the antenna circuit.

Counterpoise. A system of wires or other conductors, forming the lower capacity area of an antenna elevated above and insulated from the ground and substantially as extensive as the aerial.

Receiving Set Receiver. A device for converting radio waves into perceptible signals.

Heterodyne Reception. The process of receiving radio waves by combining the received current with locally generated alternating current. The locally generated frequency is commonly different from the frequency of the received current, thus producing beats. This is called beat reception.

Self-Heterodyne Reception (Autodyne Reception). A system of heterodyne reception through the use of a device which is both an oscillator and a detector.

Homodyne Reception. The process of detecting a wave by the aid of a locally generated wave of carrier frequency. (Sometimes called zero-beat reception.)

Super-Heterodyne Reception. A method of reception in which the received current is combined with the current from a local oscillator and converted into current of an intermediate frequency which is then amplified and detected to reproduce the original signal wave.

Intermediate Frequency. A frequency of a magnitude between that of the carrier employed in radio transmission and the frequency of modulation, and to which the carrier is converted in the super-heterodyne process of reception.

Reflex Circuit. An arrangement in which one or more amplifiers are used, each to amplify the signal both before and after detection.

Tuning. Primarily, the adjustment of a circuit or circuits to resonance. Used also to mean the adjustment of a circuit or system to secure maximum transmission of a desired signal.

Sensitivity. The degree to which a radio receiving set responds to signals of the frequency to which it is tuned.

Selectivity. The degree to which a radio receiving set is capable of differentiating between signals of different frequencies.

Detector. That portion of the receiving apparatus which, connected to a circuit carrying currents of radio frequency, and in conjunction with a self-contained or separate indicator, translates the radio-frequency power into a form suitable for operation of the indicator. This translation may be effected either by the conversion of the radio-frequency power, or by means of the control of local power. The indicator may be a telephone receiver, relaying device, tape recorder, and so on.

The most common type of detector is a vacuum tube operated on a non-linear portion of its characteristic curve, thereby converting a modulated direct current.

A tube which operates similarly to a detector tube, but the output of which does not operate an indicator, may properly be called a frequency converting tube.

Detection Coefficient. The quotient of the direct current in a radio detector with no external resistance, due to an impressed alternating voltage, divided by the square of the r. m. s. alternating voltage. As most precisely used, the term refers to a voltage so small that its value is independent of the magnitude of the voltage, in which case it is expressed by the equation.

$$\text{Detection Coefficient} = \frac{1}{2} \frac{d^2}{d} \frac{i}{e^2}$$

where e and i are respectively the voltage and current as taken from the characteristic curve of the detector with no external resistance. See Grid Detection Coefficient and Mutual Detection Coefficient.

Interference. Confusion of reception due to strays, undesired signals or other causes; also that which produces the confusion.

Attenuation. The reduction in power of a wave or a current with increasing distance from the source of transmission.

Fading. The variation of the signal intensity received at a given location from a radio transmitting station as a result of changes in the transmission path.

Swinging. The variation in intensity of a received radio signal resulting from changes in the frequency of the transmitted waves.

Nomenclature—Antenna Parts. The standard nomenclature to apply to radio antenna parts shall be as follows:

- (a) Antenna wire.
- (b) Lead-in wire.
- (c) Ground wire.
 - (1.) Receiver ground wire.
 - (2.) Protective ground wire.
- (d) Insulation.
 - (1.) Antenna insulator.
 - (2.) Lead-in insulator.
 - (3.) Wall insulator.

- (e) Ground clamp.
- (f) Lead-in connector.

This is the device which is used to fasten or connect the lead-in wire to the antenna wire.

- (g) Protective device.

This refers to the lightning arrester, regardless of type.

- (h) Supporter of antenna.

This refers to any mast or other rigging to which the antenna wire is attached.

SPECIFICATIONS

Antenna Unit Package. The standard antenna package, containing material for the installation of an outdoor antenna for a radio receiving set, shall be as follows:

- (a) **Antenna Wire—**
At least 100 feet of No. 14 American Standard Gauge Wire bare or enameled hard drawn copper or equivalent of the same cross-sectional area and tensile strength.
- (b) **Insulators—**
Not less than two insulators of glazed porcelain or glass or equivalent material preferably ribbed.
- (c) **Lead-in Insulators—**
One lead-in insulator of unglazed porcelain at least 8 in. long, $\frac{5}{16}$ in. in inside diameter; $\frac{9}{16}$ in. outside diameter or other equivalent insulator with or without rain drip.
- (d) **Lead-in and Arrester Ground Wire—**
Fifty feet of No. 14 American Standard Gauge weather-proof wire, solid or stranded.
- (e) **Wall Insulators—**
Not less than three wall insulators equivalent in insulation to a No. 6 porcelain knob.
- (f) **Interior Wire—**
Not less than twenty-five ft. of No. 18 American Standard Gauge rubber covered and braided copper wire, solid or stranded.
- (g) **Insulated Staples—**
No less than twelve insulated staples to fasten interior wire.
- (h) **Ground Clamp—**
One ground clamp.
- (i) **Protective Device—**
One lightning arrester for either outside or inside installation.
- (j) **Instruction—**
A suitable leaflet or card containing excerpts from the National Electric Code giving rules for proper erection of antenna shall be included.

If at any future time the National Board of Fire Underwriters approve as to fire risk the flat type of insulated flexible lead-in conductor, then the standard antenna package may have items in paragraphs (c), (h) and (i) modified to read as follows:

- (c) **Lead-in Insulators—**
One or two flat flexible insulated conducting strips or equivalent design.

- (h) Ground Clamp.
One or two ground clamps.
- (i) Protective Device—
One outdoor type of lightning arrester.

Antenna Installation Instructions. It shall be standard for manufacturers of receiving sets requiring outside antenna and for manufacturers and for manufacturers of outside antenna material sold in NEMA standard unit packages to include in the instruction book or instruction card accompanying the radio receiving set or antenna unit package reasonably complete instructions for erecting the antenna and a statement cautioning the user that the installation should be made in accordance with these instructions and in accordance with the National Electrical Code and the National Electrical Safety Code, as approved under the procedure of the American Engineering Standards Committee, and that the Fire Company should be requested to supply as rider on the fire insurance policy of the building in which the installation is made, to cover the complete radio installation.

Vacuum Tube Socket—Markings. The Standard Vacuum Tube Socket for the four pin vacuum tube base shall be so designed as to accommodate the Standard Vacuum Tube Base and have designation markings as follows:

- (G) to designate the Grid terminal.
- (P) to designate the Plate terminal.
- (F—) to designate the Left Hand Filament terminal, looking down on the tube socket, with the two large size tube terminal holes nearest the observer.
- (F+) To designate the Right Hand Filament terminal, looking down on the tube socket, with the two large size tube terminal holes nearest the observer.

Vacuum Tube Sockets—Color Designation. The colors for vacuum tube sockets in receiving sets shall be as follows:

- For General Purpose Tubes Dark Red
- For Special Detector Tubes Green
- For Audio Power Tubes Orange
- Suggested Standard for Future Design.

Variable Capacitors—Package Markings. It shall be standard to mark individual boxes or cartons the minimum and maximum capacitance of variable capacitors, designed for use in radio circuits, in microfarads. It is not standard to indicate the size of capacitors by marking on the carton the number of plates.

Resistors—Marking Designation. It shall be standard to designate resistors having resistance of 100,000 ohms and above in megohms and

decimal fractions thereof. Resistors having resistance below 100,000 ohms shall be designated in ohms.

Resistors—Markings Tolerance. The standard commercial tolerance for resistor markings shall be plus or minus 10%. This resistance shall be measured at or corrected for a temperature of 20 degrees Centigrade (68 degrees Fahrenheit.)

Resistors, Grid—Dimensions. The standard overall length for grid resistors shall be $1\frac{3}{8}$ inches with a tolerance of plus $\frac{1}{32}$ inch.

The maximum diameter of a standard grid resistor shall not exceed $\frac{7}{8}$ inch.

Inductors—Rating. It shall be recommended practice to rate a filter inductor with its inductance in henries at a specified frequency, alternating voltage, and direct current. The d. c. resistance should also be stated.

AUDIO APPARATUS

Audio Apparatus—Insulation Resistance. The insulation resistance of audio apparatus, such as jacks, plugs, cords and operating windings, shall be not less than 15 megohms measured between adjacent insulated conductors or between an insulated part of the metal framework. The test for insulation resistance shall be taken after 25 hours in a humidity tank at an average humidity of 90 per cent. relative and a temperature of 100 deg. F.

Radio and Audio Transformers—Instructions. It is recommended that the printed instructions furnished with all radio and audio transformers specify the use of pure resin flux only in soldering connections to the transformer terminals.

Radio and Audio Transformers—Terminal Marking. The standard arrangement and markings of radio and audio transformer terminals shall be as follows:

G—Denotes to **grid** circuit of vacuum tube.

F—Denotes to **filament** circuit of vacuum tube.

P—Denotes to **plate** circuit of vacuum tube.

+B—Denotes to **positive (+)** terminal of "**B**" battery.

PRI—Denotes winding between terminals "P" and "+B."

SEC—Denotes winding between terminals "G" and "F."

Insulation and Electrolysis Test—Audio Transformers. This test is to determine the detrimental effects of moisture on the windings of audio transformers that are usually left connected into a direct current circuit, when a radio receiver is installed for operation. The recommended test is as follows:

(a) The complete transformer should be enclosed in a humidity tank at a relative humidity of 90 per cent. and a temperature of 120 deg.

to 130 deg. F., the "+B," terminal of the primary winding being connected to the positive (+) terminal of a 200 volt direct current source, the negative (—) terminal of the source being connected to the core iron of the transformer, as well as to the plate terminal (P) of the primary winding of the transformer. A connection to the plate terminal (P) of the primary winding should be brought out for marking continuity tests of the primary so as to ascertain when the primary winding opens.

(b) The following readings should be taken at the end of each hour period:

- (1) Insulation resistance, taken between primary winding and core iron, to be expressed in megohms.
- (2) Continuity of primary winding, the result being expressed as the number of hours of operation without failure.

Audio Output Transformers and Inductors—Resistance of. It shall be standard that the ohmic resistance of audio output transformers and inductors shall be such that the d. c. resistance drop shall not exceed 10% of the applied "B" voltage.

External Output Devices. When an external output device is used, it shall be standard that the primary terminals shall not be exposed and the input leads of the device shall be permanently connected to the device where voltages of over 200 volts are used. The connecting leads shall be so insulated as to withstand the application of an alternating current test potential between conductor and between conductors and ground, of a value equal to four times the maximum direct current plate voltage used on the output tube, but shall in no case be less than 800 volts.

TESTS

Temperature Tests—Audio Apparatus. Standard audio apparatus shall withstand a continuous temperature of 125 deg. F. for a period of 12 hours without showing any physical distortion.

Loud speaker horns shall be tested for temperature in a humidity tank at a relative humidity of 90 per cent. and a temperature of 120 degrees to 130 degrees F., the horns to withstand this test for 125 hours without distortion or drooping.

Test Method—Audio Coupling Devices. The following standard test method for interstage coupling devices used in broadcasting receivers is intended primarily to produce uniformity in published characteristics, and may or may not be the best method for development purposes, and for use in the purchase of this class of apparatus. The method is such that it may be set up by any manufacturer, with the assurance that if the instructions are followed, there will be no large errors. The

method does not require expensive special equipment beyond that which is available in any well equipped radio laboratory. This standard test method is adaptable to impedance and resistance coupling, as well as to transformer coupling, and includes the range to be covered in the standard test, and to be shown in the published curves.

(a) **Principal of the Standard Method.**—A known voltage determined by a known current flowing through a known resistance is applied to the coupling device through a non-inductive resistance is applied to the coupling device through a non-inductive resistance equal to internal plate impedance of the tube, with which this coupling device is supposed to operate. Direct current equal to the corresponding plate current in that tube is flowing through this coupling device. Voltage output from the coupling device is measured at various audio frequencies by means of a tube voltmeter. Ratio of voltage output to voltage input gives "overall ratio" and is the figure, which when multiplied by amplification constant of the tube gives "amplification per stage."

(1) Flatness and height of the curve of overall ratio when plotted against frequency is a measure of quality of transformer. Schematic diagram of the Standard Testing Set is shown in accompanying cut. Its essential parts are described below.

- (b) **Oscillator**—The percentage of harmonics present in the output of the oscillator shall be not more than 5 per cent. The frequency range of the oscillator shall be from 30 to 7,000 cycles. The output circuit of the oscillator is so arranged to deliver at least .3 watts to the input potentiometer in series with 10 mfd. capacity. Type UX-210 tube or equivalent operating at, at least, 350 volts plate potential shall be the output tube of the oscillator. The output transformer of the oscillator should deliver a voltage suitable for the potentiometer used.
- (c) **Potentiometer**—The potentiometer consists of a fixed non-inductive arm "B" of X ohms in series with a non-inductive arm "AC" of $10X$ ohms (or any multiple of $10X$ ohms) so that any potential gradient "A" may be tapped off. A calibrated potentiometer or two decade resistance boxes can be used as arm "AC."
- (d) **Resistors**— R_1 is a variable non-inductive resistance having available values of 5,000, 10,000, 15,000, 20,000 and 25,000 ohms to carry 5 M. A.

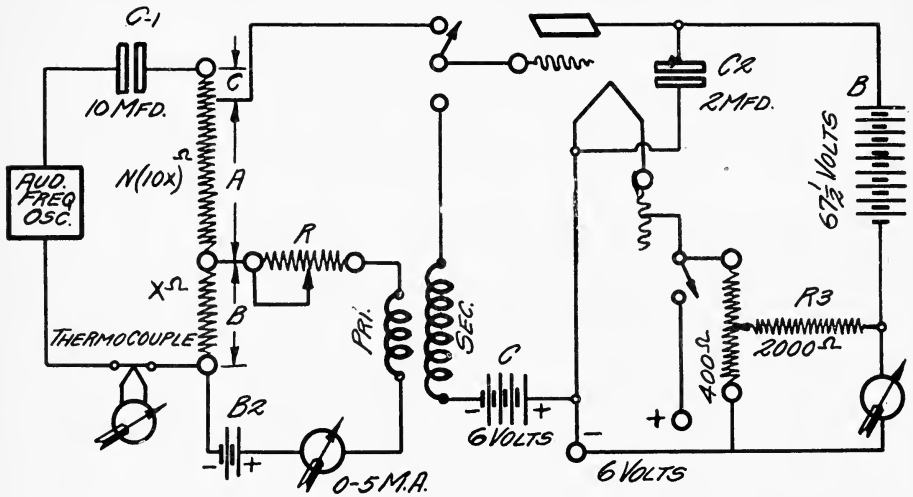

TEST METHOD AUDIO COUPLING DEVICES.

- (e) **Capacitors**— C_1 is a 10 mfd. capacitor used to isolate the oscillator from the direct current in the primary of the transformer under test.
- (f) **Meters**—The milliammeter and thermocouple 1 reads from 5 to 25 M. A. alternating current. If the current I_1 through the potentiometer can be read by some other method, as the voltage drop across a known part of arm AC, this meter can be omitted. Direct current milliammeter 2 reads from 0 to 5M.A., and need not be kept continuously in circuit.
- (g) **Batteries**— B_2 is the battery which supplies direct current through the transformer primary, thereby simulating such saturation conditions as may exist under operating conditions. Its voltage is governed by the resistance R_1 , the direct current resistance of the primary and the desired current I_2 .
- (h) **Switch**—Switch S is of the quick throw low capacity type, with the throw of the arm not over $1/16$ in. The switch must be well insulated and as free as possible from capacity effects, from the observer as well as other equipment, because it is used to transfer high impedances.
- (i) **Vacuum Tube Voltmeters**—Vacuum Tube Voltmeter as shown consists of a UX-201A tube, battery B, by-pass capacitor C_1 2 mfd., milliammeter 3, potentiometer R_2 of 400 ohms. Resistance R_2 of 2000 ohms to limit the flow of B battery current

through R_2 , switch V , and the conventional filament rheostat R_1 and battery A , for a 201-A tube. Battery C prevents the grid of voltmeter tube from becoming positive at any time. Any other type of vacuum tube voltmeter that is reliable can be used instead of the one shown.

- (j) **Connections of Coupling Device**—Coupling device is connected to the terminals of the set marked P , B , G , F . Practically every coupling device sold on the open market has its terminals marked the same way.
- (k) **Method of Operation**—Input voltage B across fixed arm, current I_2 through $M. A. 2$, and value of resistance R_1 , are given in table below. The oscillator output is regulated to give the required voltage B ; measured by current I_2 , or voltage drop across a known part of arm AC . I_2 is regulated by the voltage of battery B_2 . Switch S is placed in position U , and the Vacuum Tube Voltmeter adjusted to give a convenient deflection. S is then thrown to position T and potentiometer AC adjusted until the same deflection of voltmeter is obtained.
- (1) The voltage amplification of the coupling system is equivalent to resistance A divided by resistance B , and can be read directly from the scale of AC when AC has a value of some multiple of $10X$ ohms.
- (l) **Notes**—The probable degree of accuracy of the method is 5 per cent. at low and 10 per cent. at high frequencies. Various degrees of core saturation may be simulated by varying the current through meter 2. The values given will cover average operating conditions and will be used in all operating cases that do not require special treatment.
- (m) **Readings**—Readings are to be taken at the following frequencies: 30, 45, 60, 100, 200, 500, 1000, 2000, 3500, 5000, and 7000 cycles and at points where peaks or irregularities occur.
- (n) **Curves**—Semi-log paper, having 3 logarithmic scales, is to be used for plotting curves (form 3138 of the Codex Book Company, New York, is satisfactory). Frequency is plotted logarithmically on the horizontal axis and the standard scale is from 30 to 7000 cycles. Any portion of the curve may be shown but the complete scale shall be indicated. Amplification, or per cent. of nominal turn ratio, shall be plotted on the vertical axis and this case will be labeled as may be convenient. The horizontal scale will be marked "Frequency." The vertical scale indicates the amplification produced by the coupling device only, excluding tubes, and will be numbered and marked

accordingly. Curves made in accordance with this method, when published, may be labeled "NEMA Standard Tests."

(o) **Table of Constants—**

Transformer to be used	Voltage B	Load Res. R_1 R1	Winding Current I_2 I_2
1st	.1 V	20,000 ohms	1 ma.
2nd	.2 V	10,000 ohms	2 ma.

Voltage Breakdown Test for Loud Speakers. The Standard voltage breakdown test for all radio loud speakers, designed for use with radiocast receivers, shall be the application of 500 volt, 60 cycle, alternating current for a minimum time of 2 seconds and for a period not to exceed 10 seconds, application being made as follows:

- (a) Between the magnet core and each terminal of the winding in turn.
- (b) In no case shall this test be made directly across the two terminals of the loud speaker, as this would tend to demagnetize the permanent magnet, if the loud speaker is so equipped.

CONNECTION CORDS

Cord—Radio Head Set. The standard cord for connecting head set to a radio plug or to the terminals on a radio receiver shall conform to the dimensions given in the following table and the plug or radio receiver end shall be provided with NEMA standard pin type cord tips. Each of the three branches of this cord shall be provided with "stay" or strain cords as shown in the diagram. The color of the outer braid shall be "telephone brown" and the three conductors shall have the following color designation to indicate polarity:

- (a) Solid brown for the conductor that connects the positive (+) terminal (sleeve) of the plug or the positive (+) terminal of the radio receiver to the positive (+) terminal of the first telephone ear piece.
- (b) Black with brown thread tracer for the conductor that connects the negative (—) terminal (tip) of the plug or the negative (—) terminal of the radio receiver to the negative (—) terminal of the second telephone ear piece.
- (c) Brown with white thread tracer for the conductor that connects the negative (—) terminal of the first telephone ear piece to the positive (+) terminal of the second telephone ear piece

A	60	72	Optional
B	42	48	Optional

C	14	18	16
D	2	3	
E	2	3	
F	4		

Cord Connection—Radio Head Set. When standard head set ear pieces are connected to a NEMA standard radio head set cord, one of the ear pieces shall have the “solid brown” conductor connected to the “+” terminal and the “brown with white tracer” conductor connected to the “—” terminal, and the other ear piece shall have the “brown, with white tracer” conductor connect to the “+” terminal and “black with brown tracer” conductor to the “—” terminal.

Short Cord—Radio Loud Speakers. The standard cord for connecting a radio loud speaker or a radio phonograph attachment to a radio plug or to the terminals on a radio receiver shall have a total length, from terminals to terminals, of 6 feet, and shall be provided on the plug or radio receiver end with NEMA standard pin type cord tips. Both ends of this cord shall be provided with “stay” or strain cords not less than 4 in. long. The color of the outer braiding shall be “telephone brown” as specified for the standard radio head set cord, and the conductors shall have polarity designation as follows:

- (a) Solid brown for the conductor that connects the positive (+) terminal of the loud speaker to the positive (+) terminal (sleeve) of the radio plug or to the positive (+) terminal of the radio receiver.
- (b) Black with brown thread tracer for the conductor that connects the negative (—) terminal of the loud speaker to the negative (—) terminal (tip) of the radio plug or to the negative (—) terminal of the radio receiver.

Long Cord—Radio Loud Speakers. The standard long cord for super power or for large size cone or diaphragm radio loud speakers shall have the conductors arranged as a twisted pair and conform in construction to NEMA Standard. (Short Cord for Radio Loud Speakers) and shall be made in standard lengths of 10 ft., 20 ft., 40 ft., or 100 ft.

Potentials on Loud Speaker Cords. It shall be standard that where standard loud speaker cords are used, the maximum potential between conductors and ground shall not be in excess of 200 volts.

Extension Cords—Loud Speakers. The standard extension cord for radio loud speakers shall be of two conductors arranged as a twisted pair, shall have lengths of 10 ft., 40 ft., or 100 ft. and shall terminate

at one end in a NEMA Standard Radio Plug and at the other end in a NEMA Standard Radio Jack. Both ends of this cord shall be provided with "stay" or strain cords securely fastened to the jack and to the plug, so as to remove all strain or pull from the individual conductors.

The color of the outer braiding shall be "telephone brown" as specified for the standard radio head set cord and the conductors shall have polarity designation as follows: Solid brown for the conductor that connects the sleeve of the radio plug to the sleeve spring of the radio jack and black with brown thread tracer for the conductor that connects the tip of the radio plug to the tip spring of the radio jack.

Radio Head Set—Impedance. The impedance of standard radio head sets shall come within the limits of 9,000 ohms minimum and 25,000 ohms maximum when measured with an alternating current of 800 cycles per second.

Radio Head Set—Polarity Marking. The terminals of each telephone ear piece of a standard radio head set shall be marked with a plus sign (+) to denote the terminal to which the "positive" connection shall be made and with a minus sign (—) to denote the terminal to which the "negative connection shall be made.

NOMENCLATURE

Selector (Station Selector). The manual adjustment means by which the user of a broadcast receiver is enabled to bring one or more of its circuits into resonance with any desired signal within the range of the receiver. There are three general methods of manual station selection. In these the mechanical means used in any of the three methods may consist of direct connected drives, with or without auxiliary close adjustment means, or may consist of close adjustment means only.

Note—The use of the word "control" as applying specifically to manual tuning adjustments is not approved.

Multiple Selector. That method of manual tuning adjustment in which mechanical means are provided for setting independently each of two or more tuned circuits or groups of tuned circuits to resonance at any frequency within the range of the device.

Master Selector. That method of manual tuning adjustment in which one mechanical means is used to bring all the tuned circuits simultaneously into approximate resonance with any desired frequency within the range of the device, and additional auxiliary means are provided to bring one or more of the tuned circuits into exact resonance.

Uni-Selector. That method of manual tuning adjustments in which one and only one mechanical means is provided to the user for bringing

all tuned circuits into practical resonance at any desired frequency within the range of the receiver, there being no additional separate means for resonance adjustment and no other controls which appreciably affect the calibration of the uni-selector.

Direct Selectors. Direct selectors are those in which the motion ratio between the knob, dial, or other actuating means and the driven device is unity.

Close Selectors. Close selectors are those in which the motion ratio between the knob, dial, or other actuating means and the driven device is greater than unity.

NOTE—The auxiliary tuning adjustments in master selector arrangements will ordinarily be "close" in their effect and may be so referred to regardless of the actual mechanical motion ratio which they employ.

Volume Control. The manual adjustment means by which the user of a broadcast receiver is enabled to adjust the sound volume delivered by the sound reproducing device on any signal input, within limits depending on the strength and the sensitivity of the receiver and the sound reproducing device.

On-Off Switch. The manual means of connecting and disconnecting a source or sources of power which are supplied to the receiver.

Selectivity Control. The manual adjusting means by which the user of a broadcast receiver may produce changes in circuit to produce two or more degrees of selectivity or by which he may produce a gradual change in this respect between limits.

Broadcast Receivers—Frequency Range. The frequency range of standard broadcast receivers shall be the broadcast frequency band from 550 kilocycles (545.1 meters) to 1500 kilocycles (199.9 meters).

Terminal Markings—Receiving Set. The standard markings for binding posts or terminals shall be as follows:

- (a) The binding post for connecting the antenna wire shall be marked with the word ANTENNA or the abbreviation ANT, and the binding post for connecting the ground wire shall be marked with the word GROUND or the abbreviation GND.
- (b) Binding posts for connecting the conductors extending to a loop shall be marked LOOP 1, LOOP 2, etc., to correspond to similar markings on the loop.
- (c) The binding posts for making connections to "output" apparatus or circuits shall be marked OUTPUT.

Terminal Markings—Power Cable. It shall be standard to mark cable terminations of Radio Receivers as follows:

B + PWR
B + AMP

B + DET
 B —
 A +
 A —
 C +
 C —AMP
 C —PWR

Where additional markings are required as in additional B and C voltages, any one of the standard markings may be subdivided by using a suffix numeral, as in B+, the highest number representing the most positive terminal, and in the case of C— markings, the highest number marking the most negative terminal, for example:

B + PWR 3 (Most Positive)
 B + PWR 2
 B + PWR 1
 (A — Taken as basis of reference)
 C — PWR 1
 C — PWR 2
 C — PWR 3 (Most Negative)

The A— shall be taken as the zero point of reference as to positive and negative potential.

Color Designation for External Wiring of Radio Receivers. This color designation scheme uses solid colored outer braiding to indicate the high or positive side of the circuits and colored tracer threads to indicate the low or negative side of the circuits. Intermediates consist of two colors in a half and half diagonal weave. When one conductor is common to two or more circuits, the colors corresponding to the particular circuits are combined by using color tracer threads and a color background to indicate the circuits involved. Wires with Tracer threads shall be referred to as follows: Black-Red Tracer, Black-Green Tracer, etc. Wires with two colors in half and half diagonal weave shall be referred to as follows: Maroon-Red, Black-Red, etc. (The standard color designations, as shown on the standard color card of America, Seventh Edition, issued by the Textile Color Card Association of the United States, Inc., 50 West 42nd Street, New York, are as follows: GREEN-Emerald S-5005, RED-Geranium S-2035, YELLOW-Orange S-3005, BROWN-Gold, Brown S-3285, BLUE-Bluebird S-6065, Maroon-Magenta S-7285.) The standard color designation for cord and cable conductor used for outside connections on radio receiving sets shall be:

(a) For conductors that are individual to one circuit only:

CIRCUIT	COLOR CODE
“A” Battery	
Positive	Yellow
Negative	Black-Yellow Tracer
“B” Battery	
Highest Positive	Red
Intermediate Positive	Maroon-Red
Low Positive (Detector)	Maroon
Negative	Black-Red Tracer
“C” Battery	
Positive	Green
Intermediate Negative	Black-Green
Negative	Black-Green Tracer
Loud Speaker	
High Side (+)	Brown
Low Side (—)	Black-Brown Tracer
Antenna or Loop High Side	Blue
Loop Mid Tap	Blue-Black
Ground or Loop Low Side	Blue-Black
Battery Jumpers	Black-Blue Tracer

(b) For conductors that are common to two or more circuits:

CIRCUITS	COLOR CODE
“B” Battery Positive	
Loud Speaker Low Side	Red-Brown Tracer
“A” Battery Positive	
“B” Battery Negative	Yellow-Red Tracer
“C” Battery Positive	
“A” Battery Negative	Green-Yellow Tracer

The color designation for Cord and Cable Conductors where solid color insulation is used shall be as follows:

- (a) In case where the design of the insulating covering of the cable conductors is such as to permit of manufacturing solid colors only, with no tracer-thread as specified in NEMA Standard these solid colors should be used as the positive potential or “high side” conductors as designated in NEMA Standard.
- (b) The negative potential or “low side” conductors should be designated by a solid black covered conductor with a “tracer” color of a small patch of paint, a colored thread binding, or a colored tag, applied near the terminal of the negative lead. the color designations corresponding to the “Tracer-Thread” colors given in NEMA Standard.

- (c) In cases where a conductor is common to more than one circuit, the solid color of the conductor may indicate that it is the positive potential or "high side" of one circuit and the small patch of tracer color (provided by paint, binding or tag) may indicate that it is the negative or "low side" of a second circuit, etc.

Power Cable—Termination. It shall be standard for the power cable of the radio receiver to have separate bare ends or terminals for all A, B and C connections, so that it shall be unnecessary to make more than one connection to each terminal or wire end. This does not apply to receivers having built-in power equipment.

Output Terminals of Receiving Set, Protection of. In a receiver, where provisions are made for separate B and C voltages on the last tube, it shall be standard to protect the output terminals of the receiver, and the insulation of the B+PWR lead shall be adequate for 500 volts D. C.

WIRING AND CONNECTIONS

Jacks and Plugs—Polarity. The standard polarity indication on the radio plugs shall be a "+" marking on or adjacent to the terminal that connects to the sleeve of the plug. All jacks used in radio receivers for the connection of head sets and loud speakers shall be so wired to the receiver circuits that positive (+) polarity of "B" battery shall be connected to the "sleeve" or body of the plug, when the plug is inserted in the jack.

Removing Potentials from Exposed Sleeves of Radio Jacks. It shall be standard to arrange radio spring jacks mounted in radio receivers so that all electrical potentials will be removed from all exposed metal parts of the sleeve connection.

Wiring Diagrams—Receiving Set. It shall be standard to supply with each receiving set a picture type wiring diagram showing in perspective the terminals, batteries, etc., with the external electrical connections.

Power Cable Connection to Receiver. It shall be standard to permanently attach the battery or power supply cable to the radio receiver and this point of attachment shall not be readily accessible.

It shall be standard to make wholly inaccessible all conductors in a receiving set to which a potential of over 200 volts may be applied under any practical operating condition. If the compartment containing such terminals or attachment is ventilated openings shall be either not larger than $\frac{1}{4}$ in. in greatest dimension or so designed, located or protected that the average small tool or operator's hand cannot be inserted

and come in contact with current carrying parts of potentials of over 200 volts.

MARKINGS

Control Markings—Receiving Set. The standard marking for the knob, dial or pointer controls on radio receivers shall be as follows:

(a) For tuning controls—

Either STATION SELECTOR 1, STATION SELECTOR 2, STATION SELECTOR 3, etc., or SELECTOR 1, SELECTOR 2, SELECTOR 3, etc., at the option of the manufacturer.

(b) For regeneration adjustment controls INTENSITY

(c) For signal volume adjustment controls VOLUME

Controls—Receiving Set. It shall be standard practice to arrange the controls on radio receiving sets so that clockwise rotation shall give an increase in voltage on tubes or an increase in signal volume on the volume control.

It shall be standard practice to arrange the station selecting controls on a radio receiving set so that the reading shall increase in numeral value with clockwise rotation of the dial, or pointer and so that the actuating knob shall turn in the same direction as the index.

When the station selectors are calibrated, frequency markings shall preferably be used. In this case, the rotation of the station selector control in a clockwise direction shall increase the frequency setting of the circuit and the marking on the dial or panel shall be governed accordingly.

Testing Instructions—Dry Cell "A" Batteries. This standard covers tests to determine the operating characteristics of the type of dry cell used for vacuum tube filament current supply in radio receivers. Standard dry cell "A" batteries shall be:

(a) Heavy Radio Test—

Not less than 3 dry cells of each kind shall be connected in and shall be discharged at a constant current of 0.25 ampere for a continuous period of 4 hours on each of 6 days per week with intervals of not less than 16 hours intervening between the discharge periods. The following readings shall be taken:

(1) Initial open-circuit voltage.

(2) Initial closed-circuit, or working, voltage.

(3) Closed circuit voltage readings at the end of each discharge period.

The test shall be considered completed, when the closed circuit voltage at the end of a period of discharge falls below 0.9 volts per cell. The test shall be reported in terms of hours of actual discharge during the test period.

(b) Light Radio Test—

Not less than 3 cells of each kind shall be connected in series and shall be discharged at constant current of 0.125 ampere for a continuous period of 2 hours on 6 days per week with intervals of not less than 16 hours intervening between the discharge periods.

- (1) Initial open-circuit voltage of the battery.
- (2) Initial closed circuit, or working, voltage.
- (3) The closed-circuit voltage at the end of the third and sixth discharge period of each week.

The test shall be considered completed when the closed circuit voltage at the end of a period of discharge falls below 0.9 volt per cell. The test shall be reported in terms of hours of actual discharge during the test period.

NOTE—When this test is used for cells smaller than the $2\frac{1}{2}$ by 6 in. size, closed-circuit readings shall be taken at the end of each period.

(c) Voltage and Temperature Readings—

(1) Voltage—

The voltage of individual cells for the "A" battery shall be measured with a voltmeter having a resistance of not less than 100 ohms per volt, and having not less than 50 divisions per volt on its scale.

(2) Temperature—

The standard temperature for making tests shall be 20 deg. Deviations from this temperature shall be stated.

Testing Instructions—Dry Cell "B" Batteries. This standard covers tests to determine the operating characteristics of the type of dry cell battery used for vacuum tube plate current supply in radio receivers. These tests are specified for batteries containing 15 cells (nominal voltage of the battery 22.5 volts). Standard tests for standard dry cell "B" batteries shall be:

(a) 5000 Ohm Continus Test—

The "B" batteries shall be discharged continuously through 5000 ohms per battery until the closed-circuit voltage of the of the battery has fallen below 17 volts. The following readings shall be taken and the results of this test shall be reported in terms of hours of discharge during the test period:

- (1) Initial open-circuit voltage.
- (2) Initial closed-circuit voltage.
- (3) Closed-circuit voltages twice daily for the smallest size and similar readings daily for intermediate and large sizes.

(b) 5000 Ohm Intermittent Test—

Applicable only to Dry Cell "B" batteries made from A, B, C and D size cells. The "B" batteries shall be discharged through 5000 ohms for a continuous period of 4 hours on of 6 days per week with intervals of not less than 16 hours intervening between the discharge between the discharge period. The following readings will be taken and this test shall be considered completed when the closed-circuit voltage at the end of a period of discharge falls below 17 volts; the result of this test being reported in terms of hours of actual discharge during the test period:

- (1) Initial open-circuit voltage.
- (2) Initial closed-circuit, or working voltage.
- (3) Closed-circuit voltage readings at the end of the third and sixth discharge period of each week, except for readings of the smallest size of battery which shall be made daily.

(c) 1250 Ohm Intermittent Test—

Applicable only to dry cell "B" batteries made from "D" and "F" size cells. This test shall be as specified for the 5000 ohm Intermittent Test with the exception that 1250 ohms shall be used in place of 5000 ohms.

(d) Voltage and Temperature Readings—

(1) Voltage—

The voltage of "B" type batteries shall be measured with a voltmeter having not less than 50,000 ohms resistance, and a scale of not less than 5 divisions per volt. Readings shall be estimated to the nearest 1/10 volt.

NOTE—If a voltmeter conforming to the above quantity is not available, voltmeters of lower resistance may be used to obtain approximate values. The error introduced will depend upon the resistance of the voltmeter and the condition and size of the battery. A voltmeter having 5,000 ohms resistance, for example, may give indications by as much as 10 per cent below the true value when used to measure a battery containing cells $1\frac{1}{4}$ by $2\frac{1}{4}$ in. This error may be increased on cells of smaller size.

(2) Temperature—

The standard temperature for making tests shall be 20 deg. C. Deviations from this temperature shall be stated.

“A” BATTERIES

Dry Cell “A” Battery—Type of Terminals. It is recommended that all radio “A” battery dry cells be equipped with only the standard screw kunrled nut type terminal.

This standard covers the class of dry cell which is made and sold primarily for use with dry cell tubes, and which has a somewhat greater capacity on radio loads than the general purpose cell.

Dry Cell “A” Battery—Location of Terminals. It shall be standard to locate one of the terminals of the dry cell “A” battery in the center of the top and the other near one side or at the edge of the top.

This standard covers the class of dry cell which is made and sold primarily for use with dry cell tubes, and which has a somewhat greater capacity on radio loads than the general purpose cell.

Dry Cell “A” Battery—Terminal Markings. It is recommended that “A” battery dry cells when sold in individuals cartons shall bear the following notations near the top of the cartons:

Positive (+) Terminal in Center.

Negative (—) Terminal on Outside.

This standard covers the class of dry cell which is made and sold primarily for use with dry cell tubes, and which has a somewhat greater capacity on radio loads than the general purpose cell.

Dry Cell “A” Batteries—Shape of Cartons. It is recommended that dry cell “A” batteries be made with round cartons.

Dry Cell “A” Batteries—Dimensions. It shall be standard to define the dimensions of a dry radio “A” cell as follows:

Diameter (without jacket).....2½ inches

Height6 inches

A deviation of 1/16 inch shall be allowable in diameter and a deviation of 1/8 inch in height including terminals.

Height6¾ inches

Diameter2⅝ inches

Dry Cell “B” Batteries—Designation of Types. The standard system of designation of types of dry cell “B” batteries shall be as shown in the following examples:

- H-15-D
- H-30-D
- V-15-B
- V-30-F

in which “H” represents the horizontal form of radio batteries, of which all of the cells are arranged vertically in single horizontal layer. “V” represents the vertical construction of radio battery in which the cells are arranged in layers or groups, one above the other. The

numerals represent the number of cells per battery. The last letter represents the size of cell as follows:

"A" represents cell measuring $\frac{5}{8} \times 1\frac{7}{8}$ in.

"B" represents cell measuring $\frac{3}{4} \times 2\frac{1}{8}$ in.

"C" represents cell measuring $1\frac{1}{8} \times 1\frac{11}{16}$ in.

"D" represents cell measuring $1\frac{1}{4} \times 2\frac{1}{4}$ in.

"E" represents cell measuring $1\frac{1}{4} \times 2\frac{7}{8}$ in.

"F" represents cell measuring $1\frac{1}{4} \times 3\frac{1}{16}$ in.

NOTE—The foregoing system of designation of types of dry cell "B" batteries was arrived at by the Committee of Battery Manufacturers, which was appointed by the Bureau of Standards and which met at New York City on June 12th, 1924. This system of designation was subsequently approved and adopted by the Battery Committee of the Radio Apparatus Section. A. M. E. S.

Dry Cell "B" Batteries—Terminals. This standard covers the location and marking of terminals on the type of dry cell battery used for vacuum tube plate current supply in radio receivers.

(a) Types of Terminals—

It shall be standard to have the terminals on dry cell "B" batteries of the knurled nut type or spring clip type.

(b) Marking of Terminals—

The standard designation of polarity shall be the signs + and

The use of voltage figures in conjunction with the polarity sign shall be standard only at the positive terminal or terminals thus, $+22\frac{1}{2}$ or +45.

(c) Location of Terminals on $22\frac{1}{2}$ Volt (15-Cell Batteries—

It shall be standard to locate battery terminals as follows:

(1) On batteries of either the horizontal or vertical form the negative terminal shall be in the left front corner.

(2) In the horizontal form the last positive (+) terminal shall be in the right rear corner.

(3) In the vertical form (which will presumably have only one positive terminal) the last positive (+) terminal shall be in the right front corner.

NOTE—The standard position of the label shall be on the wider of the two vertical surfaces.

All of the above terminal locations are with respect to the label.

(d) Location of Terminals on 45-Volt (30-cell Batteries)—

The standard terminal arrangement on three-terminal 45-volt "B" batteries (—, $+22\frac{1}{2}$, +45) of the vertical form shall be as follows:

(1) The negative terminal shall be in the left front corner.

- (2) The +45 terminal shall be at the right front corner.
- (3) The +22½ terminal shall be approximately midway between the negative terminal and the +45 terminal.

NOTE—The front face of the battery shall be that vertical surface of greatest area. This terminal arrangement, as respects the negative and the last positive terminal will then be uniform with the standard for 22½ volt "B" batteries of the vertical form.

Dry Cell "C" Batteries—Terminals. This standard covers the type and marking of terminals on the type of dry cell battery used for the negative grid potential of radio receiving set vacuum tubes.

(a) Type of Terminals—

It shall be standard to have the terminals on dry cell "C" batteries of the knurled nut type or spring clip type to take the Nema Standard spade type cable terminal.

(b) Marking of Terminals—

The standard designation of polarity shall be the signs plus (+) and minus (—). The use of voltage figures in connection with the polarity sign shall be standard only at the negative terminal or terminals, thus (—3) or (—4½).

(c) In the case of a battery which is suitable for use either as a "B" Battery or "C" Battery, the marking shall be that of the Nema Standard for "B" Batteries.

MAXIMUM-MAXIMUM DRY CELL "B" AND "C" BATTERY DIMENSIONS

The standard for maximum-maximum dry cell "B" and "C" battery dimensions shall be as follows:

STANDARD "B" AND "C" BATTERIES

22½(*)	Horizontal	Portable	4¼	2⅝	3⅜
22½	Horizontal	Large	6⅓	4⅜	3⅓
45	Vertical	Large	8¼	3⅝	7⅓
45	Vertical	Heavy Duty	8⅜	4⅞	8
4½	Horizontal	Standard "C"	4⅓	1½	3⅞

SPECIAL "B" BATTERIES

22½	Horizontal	Portable	3½	2⅜	3⅞
22½	Vertical	Portable	3⅝	2⅓	6⅞
22½	Vertical	Large	4⅓	3⅜	7¾
45	Horizontal	Large	8⅞	6⅓	3⅓

(*) This is also standard "C" battery for power tubes which require 22½ volts negative grid bias.

The dimensions are the maximum-maximum factory tolerance occurring among eleven brands of dry cell "B" and "C" batteries.

In designing battery compartments, ⅛ in. between each battery and ¼ in. at top, bottom and four sides around the group of batteries should be added to the above dimensions so as to allow for the expansion of the battery and to provide space for placing and connecting battery cables.

Class I	Class II	Class III
16-S		H-3-B
H-15-B	H-15-A	H-5-B
V-30-D	V-15-D	
V-30-F*		
H-3-D		

Standard High Voltage "C" Battery. The standard battery for high voltage grid bias purposes shall be the H-15-B size with taps (+) ($-4\frac{1}{2}$) ($-16\frac{1}{2}$) and ($-22\frac{1}{2}$ V) and if possible this battery shall be marked so that it can be used as a "B" or "C" battery.

H-3-D Battery Terminals. It shall be standard to provide either two or four terminals on the H-3-D battery. The two terminals shall be marked + and $-4\frac{1}{2}$ V, the four terminals shall be marked +, $-1\frac{1}{2}$ V, -3 V and $4\frac{1}{2}$ V.

H-15-B Battery—Terminals. It shall be standard to provide the the H-15-B Battery with five terminals to be marked as follows: +, -3 V, $-4\frac{1}{2}$ V, $-16\frac{1}{2}$ V and $-22\frac{1}{2}$ V.

Storage "A" Batteries—Capacity Rating. It shall be standard to rate filament heating storage "A" batteries in ampere-hours based upon a continuous discharge at the 100-hour rate, at 80 deg. F. cell temperature, to a cut-off voltage of 1.75 volts per cell. The ampere discharge rate, for testing purposes, shall be determined by dividing the manufacturer's ampere-hour capacity rating of the battery by 100.

A battery which fails to deliver its rated capacity on the third repeated cycle of charge and discharge, under the conditions specified, shall be considered to be improperly rated.

"B" BATTERIES

Storage "B" Batteries Capacity Rating. It shall be standard to rate plate-current storage "B" batteries in milliamperere hours, based upon a continuous discharge at the 200-hour rate, at 80° F. cell temperature, to a cut-off voltage of 1.75 volts per cell. The milli-ampere discharge rate, for testing purposes, shall be determined by dividing the manufacturer's milli-ampere-hour capacity rating of the battery by 200.

A battery which fails to deliver its rated capacity on the third repeated cycle of charge and discharge, under the condition specified, shall be considered to be improperly rated.

Storage "B" Batteries—Number of Cells. It shall be recommended practice to build "B" storage batteries in units of 20 cells and in multiples thereof as the equivalent of 30 and 32 cell, so-called 45-volt dry battery units.

TERMINALS

Storage Battery Terminals. Storage batteries for filament or plate supply shall be provided with either lead-covered spring clips or other suitable means adapted to receive the NEMA Standard Spade Type Cable terminal, so arranged as to minimize possible corrosion of the terminal and the connecting lead, and plainly marked for polarity with (+) and minus (—) signs.

MISCELLANEOUS

Storage Battery Circuits—Fusing. For the purpose of this standard, any radio installation in which the energy for the filament, or plate circuits, or both, is supplied from storage batteries, shall be considered as consisting of three essential components, namely, the receiver, the storage battery, or batteries, and the charging means.

It shall be standard for any manufacturer who supplies any two, or all three, of these components to include in the assembly a fuse, or fuses, as required by Article 37 of the National Electric Code.

It shall be standard for manufacturers of radio receivers and charging devices, sold as separate units, for assembly into a complete equipment by the customer, to include in the accompanying instruction card or book, a statement to the effect that the complete installation, if it include storage A or B batteries, or both, must also include Fuses."

Socket-Power Unit. A socket-power unit is any device suitable for supplying "A," "B" and/or "C" battery voltages to a radio receiving set from the house lighting supply circuit by the throw of a switch. and the letters "A," "B" and/or "C" prefixed to indicate the class of

The name "Socket-Power" shall be written as a compound word service provided by the unit.

Standard Term—Socket-Powered. It shall be standard to use the term "socket-powered" to describe any radio receiver so equipped by the manufacturer that it receives its filament or heater and/or plate supply directly or through storage devices from the lighting circuit by the throw of a switch.

TERMINALS AND SWITCHES

Terminals—Socket-Power Unit. All standard power-units shall be provided with output binding posts or spring clips, adapted to receive NEMA standard spade type terminal.

Socket-Power Deviecs—Terminal Marking. It shall be standard that the terminals of the socket power unit shall bear the same markings as the radio receiver terminals insofar as they are needed for the particular type of socket-power unit. Where additional markings are required, as for additional B+ and C— voltages, any one of the above standard markings may be subdivided by using a suffix numeral. For example, where three B+ taps for different power tube voltages are

used with the corresponding C— potential taps, the complete set of terminal markings would be as follows:

B + PWR 3 (Most Positive)
B + PWR 2
B + PWR 1
B + AMP
B + DET
B —
A +
A —
C +
C — AMP
C — PWR 1
C — PWR 2
C — PWR 3 (Most Negative)

In any case, the numerals used shall proceed each way from the A— terminal which latter shall, in all cases, be taken as the basis of reference as to positive and negative potential.

Socket-Power Unit Disconnect Switch. Whenever a house supply voltage is not continuously necessary in a socket-power unit, there shall be a master control switch for the purpose of disconnecting the socket-power unit from the supply line.

RATINGS

Input Voltages—Socket-Power Devices. It shall be standard to rate socket-power devices at 115 volts and to design socket-power devices to function over the range of input voltages of 110—6 per cent. to 120+6 per cent.

DESIGN AND CONSTRUCTION

Socket Power—Design and Construction. The enclosing case or cabinet of a socket power device shall enclose all current carrying parts of the device except primary leads and secondary terminals.

Current carrying parts of the secondary in a socket power device, the voltage of which does not exceed 25 volts, may be exposed, provided the power input to the device does not exceed 150 watts when such parts become short circuited.

The current carrying parts of the tube sockets in a socket power device shall be enclosed although the device may be so designed that tubes may be replaced without opening the case.

In a socket power device, transformers, inductors, capacitors, and other such units which are conductively connected to a light or power circuit shall be enclosed in cases of non-combustible material.

Metal enclosures used in socket power devices shall be enameled or otherwise suitably protected against corrosion.

When the cabinet or enclosing case of a socket power device is ventilated, openings shall be either not larger than $\frac{1}{4}$ inch in greatest dimension or so designed, located, or protected that the average small tool or the operator's hand cannot be inserted and come in contact with current carrying parts of the primary circuit or of a secondary circuit involving potentials exceeding 200 volts.

Where a flexible cord of the primary circuit passes into the enclosing case of a socket power device it shall be protected by an insulating bushing with smoothly rounded edges. Suitable strain relief shall be provided in the flexible cord.

In a transformer used in a socket power device, which is connected to the lighting or power circuit, it shall be standard to insulate the primary from the core, case, and secondary winding.

It shall be standard to insulate all wires in a socket power device which are accessible when alive and the insulation shall be suitable for the voltages involved and the temperatures attained under any conditions of actual use.

It shall be standard in a socket power device to maintain a spacing of not less than $\frac{1}{2}$ in. over surface or through air between exposed live metal parts of the primary or supply circuit and the case, except where location and relative arrangement of the parts is such that permanent separation is assured.

It shall be standard to provide exposed socket power secondary terminals with insulated nuts where potentials in excess of 25 volts are involved.

It shall be standard to mark socket power devices plainly with the name of the manufacturer, and the rating of the primary supply or input in volts, frequency, and amperes or watts. The secondary output rating shall be stated in the accompanying instructions or on the device.

It shall be standard to provide an installation or instructions with socket power devices.

Standard Term—Fixed Paper Capacitors. It shall be standard that the term Capacitor be used to designate the device commonly known as the electrostatic condenser of fixed capacitance.

TESTS

Voltage Tests—Fixed Paper Capacitors. The standard voltage test for paper capacitors shall be a single application of three times the rated voltage given in standards 334-214 and 334-215 for five seconds, immediately discharging the capacitor through a resistance of 50 ohms or more.

Capacitance Tolerance—Fixed Paper Capacitors. The standard allowable tolerance in capacitance for standard paper capacitors shall be minus 5 per cent. or plus 15 per cent. of the rated value capacitance or individual capacity when a number of capacitors are grouped together in a single container.

Working Voltages—Fixed Paper Capacitors. The standard smooth (uniform) direct working voltages for capacitors for continuous duty when operating at a temperature not in excess of 110° Fahrenheit shall be 175 volts, 350 volts, 750 volts and 1000 volts.

The standard root means square (r.m.s.) alternating working voltages for capacitors for continuous duty at a frequency not exceeding 500 cycles sine wave and an operating temperature not exceeding 110° Fahrenheit shall be 85 volts, 175 volts, 275 volts, 375 volts and 500 volts.

Insulation Resistance—Fixed Paper Capacitors. The standard insulation resistance shall not be less than 500 megohm-microfarads as determined by the product of the measured insulation resistance and the measured capacitance of the capacitor when the reading is taken on a sensitive microammeter not less than three minutes after applying a direct voltage of 250 at a temperature 68° F. (20° C.).

NOTE—A suggested method of measuring capacitor insulation is a circuit consisting of a 250-volt battery in a series with a fairly dead beat sensitive microammeter and the capacitor.

Power Factor—Fixed Paper Capacitors. It shall be recommended practice for manufacturers of fixed paper capacitors to state the Power Factor of the capacitor when operating at alternating voltages.

Inductance—Fixed Paper Capacitors. It shall be recommended practice for manufacturers of fixed paper capacitors to minimize the inductance of their capacitors when they are to be employed to by-pass high frequency currents.

CONTAINERS AND MOUNTINGS

Containers—Fixed Paper Capacitors. The standard metal container for fixed paper capacitors shall be made of a substantial gauge metal having moisture proof seams and a securely fastened cover with a rectangular opening in it centrally located for bringing out the terminals. The corners of the container may be either right angled or slightly rounded. Mounting lugs may be provided. Standard containers shall have the following dimensions:

Height	Width	Breadth
5 inches	2 $\frac{9}{16}$ inches	2 inches
5 inches	2 $\frac{1}{16}$ inches	3 $\frac{5}{8}$ inches
5 inches	2 $\frac{9}{16}$ inches	4 $\frac{1}{2}$ inches
5 inches	5 $\frac{1}{16}$ inches	3 inches
5 inches	5 $\frac{7}{16}$ inches	5 inches

Allowable tolerance is plus or minus 1/16 inch.

Suggested Standard for Future Design.

Mounting—Fixed Paper Capacitors. It shall be standard to install capacitors so that the cover or terminal side of the capacitor will be the top side bounded by the width and breadth.

Suggested Standard for Future Design.

Terminals—Fixed Paper Capacitors. It shall be standard to use rigid hot tinned metal terminals projecting through the opening in the cover of the container at least 5/16 inch and not more than 3/8 inch from the outside of the cover.

Suggested Standard for Future Design.

Vacuum Tube. A device consisting of a number of electrodes contained within an enclosure evacuated to a low pressure. This term is also commonly used less broadly in referring to the type of vacuum tube having grid, plate and filament (triode).

Diode. A type of vacuum tube containing two electrodes which passes current wholly or predominantly in one direction.

NOTE—A vacuum tube having a single cathode and two anodes which operate alternately may properly be called a **double diode**.

Triode. A type of vacuum containing an anode, a cathode and a third electrode, in which the current flowing between the anode and the cathode is controlled by the relative potential of the third or control electrode.

Cathode. The electrode to which the current flows through the vacuous space. The cathode is usually the source of the electron emission which constitutes this current.

Filament. The cathode in the common type of vacuum tube (triode).

Filament Voltage. The voltage between the terminals of the filament.

Filament Current. The current supplied to the filament to heat it.

NOTE—When the filament is heated by direct current which is not large in comparison with the plate current, the filament current is ordinarily measured at that filament terminal where it is the larger.

Control Electrode. The electrode, the relative potential of which controls the current flowing between the anode and the cathode.

Grid. The common name for the control electrode in a vacuum tube.

Grid Potential. The electric potential of the grid relative to the cathode.

Grid Current. The conduction current passing from the grid through the vacuous space.

Reserved Grid Current. The conduction current passing to the grid through the vacuous space.

Grid Conductance. The quotient of the change in grid current divided by the change in grid potential producing it, under the condition of constant plate potential. As most precisely used, the term refers to infinitesimal changes, as indicated in the defining equation

$$\text{Grid conductance, } g_g = \frac{d i_g}{d e_g}, \quad e_p = \text{const.}$$

NOTE—The grid conductance is the resistance component of the input admittance of the vacuum tube.

Grid Characteristic Curve. The curve plotted between grid potential as abscissa and grid current as ordinate.

Grid Detection Coefficient. The quotient of the change in the direct grid current produced in a vacuum tube with no external grid or plate resistance, due to an impressed alternating grid voltage, divided by the square of the r.m.s. alternating voltage. As most precisely used, the term refers to a grid voltage so small that its value is dependent of the magnitude of the voltage, in which case it is expressed by the equation.

Grid Capacitor. A capacitor connected in series in the grid or control circuit of a vacuum tube.

Grid Leak. A resistor usually of very high resistance, used in association with a capacitor and connected directly or indirectly between the cathode and the grid of a vacuum tube.

Anode. The electrode from which the current flows through the vacuous space.

Plate. The common name for the anode in a vacuum tube.

Plate Potential. The electric potential of the plate relative to the cathode.

NOTE—If the cathode is a filament heated by direct current, its negative terminal is ordinarily taken as the datum of potential; if heated by alternating current, its mid-point is taken as the datum.

Plate Current. The conduction current passing from the plate through the vacuou space.

Amplification Factor. A measure of the effectiveness of the grid potential relative to that of the plate potential in affecting the plate current; it is the quotient of the change in plate potential divided by the negative change in grid potential, under the condition that the plate current remains unchanged. As most precisely used, the term refers to infinitesimal changes in the potentials as indicated in the defining equation.

Mutual Conductance. The quotient of the change in plate current divided by the change in grid potential producing it, under the condition of constant plate potential. As most precisely used, the term refers to infinitesimal changes, as indicated in the defining equation. The unit ordinarily used is the micromho.

NOTE I—In rare cases, when the dependence of the grid current on the plate potential is to be considered the following terms and symbols may be employed:

Inverse amplification factor

Inverse mutual conductance,

Plate Conductance. The quotient of the change in plate current divided by the change in plate potential producing it, under the condition of constant grid potential. As most precisely used, the term refers to infinitesimal changes, as indicated in the defining equation.

NOTE I—The plate conductance is the resistive component of the internal output admittance of a vacuum tube.

Plate Resistance. The reciprocal of the plate conductance.

Plate Characteristic Curve. The curve plotted between plate potential as abscissa and plate current as ordinate.

Plate Inductor. A coil of relatively high inductance inserted in the anode supply circuit of a vacuum tube amplifier, modulator, or oscillator to maintain substantially constant current in this circuit throughout the cycle of the amplified or generated current.

Filament Capacity. (Cf)—The sum of the direct capacities between the filament and all other conductors of a vacuum tube.

Grid Capacity. (Cg)—The sum of the direct capacities between the grid and all other conductors of a vacuum tube.

Plate Capacity (Cp)—The sum of the direct capacities between the plate and all other conductors of a vacuum tube.

Direct Capacity (C)—between two conductors—The quotient of the charge produced on one conductor by the voltage between it and the other conductor divided by this voltage, all other conductors in the neighborhood being at the potential of the first conductor.

Grid Plate Capacity. (Cgp)—The direct capacity between the grid and the plate.

Grid-Filament Capacity. (Cfg.)—The direct capacity between the grid and the filament.

Plate-Filament Capacity. (Cpf)—The direct capacity between the plate and the filament.

NOTE I—All capacities are ordinarily understood to be taken with the vacuum tube in its completed form but not in its socket or other holder.

NOTE II—The capacities **C_{pf}**, **C_{gf}** and **C_{gp}** are not those ordinarily directly measured, but are computed from the direct capacities which can be directly measured, in accordance with the following equations:

Internal Output Impedance. (of any device having output terminals)—The quotient of the alternating voltage impressed on the output terminals divided by the alternating current thereby produced at these terminals, in the absence of impressed alternating voltages at other points.

NOTE I—This is sometimes called simply “output impedance,” but the prefix “internal” is preferred in order more surely to distinguish it from the impedance of the external output circuit.

Internal Output Admittance. The reciprocal of internal output impedance.

Input Impedance. (of any electrical device)—The quotient of the alternating voltage impressed on the device divided by the alternating current thereby produced at these terminals, in the absence of impressed alternating voltages at other points.

Plate Characteristic Curves of Audio Output Tubes

Explanatory Note

In the past it has been customary to represent tube performance in terms of mutual characteristics—plate current vs. grid voltage at constant plate voltage. Where the performance of the tube with some finite load is of interest the plate characteristics—plate current vs. plate voltage at constant grid voltage—are likely to be more useful.

The accompanying cut on the UX 120 shows the plate characteristic curves for a series of grid potentials varying from 0 to 62.5 volts negative, and thus relates the three variables definitely. For example if we wish to know the bias required to produce a plate current of 7.5 ma at 120 volts we see from the print that the curve marked -17.5 runs almost exactly through this point and hence the bias is approximately -17.5 volts.

If the tube is working into some finite load circuit a change in plate current will cause a corresponding change in plate voltage. An example will illustrate the method of introducing this additional relation. If the UX 120 is operating at 135 volts on the plate -22.5 volts on the grid and the plate load is a 6500 ohm resistance, then the variation in plate voltage when the plate current changes may be read directly from the 6500 ohm line on the print. This line is drawn with a slope of $1/6500$ amp. per volt, or 0.145 M. A. per volt, through whatever point is chosen

as the operating point (in this case +135 V. Eb. —22.5 V. Ec). From this line we see that if the plate current rises from its normal value of 7 M. A. to, say 13.2 M. A., the plate potential will fall to 95.5 volts. The grid voltage which corresponds to 13.2 ma and 95.5 volts is 0. as the curve marked $E_c=0$ passes through the point. Then a signal which changes the grid potential from —22.5 volts to 0 will increase the plate current from 7 to 13.2 M. A. and decrease the plate potential from 135 volts to 95.5 volts. If the signal is assumed to be sinusoidal and of peak value 22.5 volts, during the succeeding half cycle the grid will reach instantaneously a potential of —45 volts. Our 6500 ohm line meets this (dotted) —45 curve at 1.5 M. A., 170 volts. We have assumed a signal which swings the grid through a range of 45 volts. The plate swings from 170 to 95.5 or 74.5 volts. The corresponding voltage amplification

$$74.5$$

is the ratio $\frac{74.5}{45}$ or 1.65. The plate current swing is from 13.2 to 1.5 or

$$45$$

11.7 M. A., corresponding to .26 M. A. per volt. The product of these two factors is .429 milliwatts per volt squared. The power output is equal to the RMS signal voltage squared, multiplied by two factors is .429 milliwatts per volt squared. The power output is

$$2$$

.429: — + .429 = 107 milliwatts. It should be noted that these calculations are of little value if the operating conditions are so chosen that the plate current falls to values in the region where the plate characteristics are curved.

$$15.9$$

calculations are of little value if the operating conditions are so chosen that the plate current falls to values in the region where the plate characteristics are curved.

RECTIFIER TUBES

Hot Cathode Rectifier Tubes Base Connection. It shall be standard to connect the filament terminals to full wave hot cathode rectifier tubes to the large pins, and the anodes separately to the plate and grid pins of the vacuum tube base.

It shall be standard to connect the filament terminals of a half wave hot cathode rectifier tube to the large pins and the anode to the plate pin of the vacuum tube base.

Cold Cathode Rectifier Tubes Base Connection. It shall be standard to connect the anodes of a full wave cold cathode rectifier tube to the large pins and the cathode to the plate pin of the vacuum tube base. Standard 340-412.

It shall be standard to connect the cathode of a half wave cold cathode rectifier tube to the plate pin and the anode to the diagonally opposite pin of the vacuum tube base.

Input Admittance. The reciprocal of input impedance.

Mutual Detection Coefficient. (Of a vacuum tube) The quotient of the change in the direct plate current produced in a triode with no external grid or plate resistance, due to an impressed alternating grid voltage, by the square of the r.m.s. alternating voltage. As most precisely used, the term refers to a grid voltage so small that its value is independent of the magnitude of the voltage, in which case it is expressed by the equation

Mutual Characteristic Curve (Grid-Plate Characteristic Curve). The curve plotted between the grid voltage as abscissa and the plate current as ordinate.

Electron Emission. The phenomenon of the liberation of electrons for the surface of a body into the surrounding space, usually under the influence of heat, ultra-violet rays, x-rays, impact excitation, or chemical disintegration.

Emission Current. The value of the current carried by electrons emitted from a cathode under the influence of a voltage such as will draw away all the electrons emitted.

Emission Characteristic Curve. The curve fitted between a factor controlling electron emission (such as the temperature, voltage or current of the cathode or filament) as abscissa and the emission current from the cathode or filament as ordinate.

Thermionic. Relating to electron emission under the influence of heat.

TUBE CHARACTERISTICS









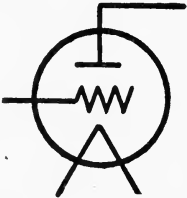

General Purpose Tubes.

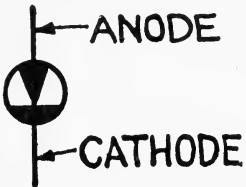
General Purpose Vacuum Tubes.

Audio Output Tubes

Audio Output Vacuum Tubes.

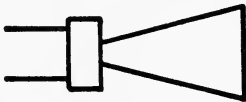
Tube	Type Base	Overall Length Diam.		in. Type	Amp.	Volts	Tested at Plate Grid		Average Characteristics			
		in.	in.				volts	volts	factor	Amp. Mutual	Plate Imped.	Plate Current
WX-12	Large Std.	4 $\frac{1}{8}$	1 $\frac{3}{8}$	Oxide	0.250	1.1	45	0	6.7	380	17,500	1.5
							67 $\frac{1}{2}$	0	6.7	475	14,000	3.0
							90	0	Not recommended.		
							90	-4 $\frac{1}{2}$	6.5	450	14,500	2.5
UX199	Small Std.	4 $\frac{1}{8}$	1 $\frac{3}{8}$	Thor. Tungs.	0.060	3	45	0	6.6	370	18,000	1.5
							67 $\frac{1}{2}$	0	6.6	450	14,500	3.0
							90	0	Not recommended.		
							90	-4 $\frac{1}{2}$	6.6	425	15,500	2.5
UX201A	Large Std.	4 $\frac{1}{8}$	1 $\frac{3}{8}$	Thor. Tungs.	0.250	5	45	0	8	640	12,500	1.75
							67 $\frac{1}{2}$	0	8	890	9,000	3.5
							90	0	8	1070	7,500	6.0
							90	-4 $\frac{1}{2}$	8	725	11,000	2.5
UX-112	Large Std.	4 $\frac{1}{8}$	1 $\frac{3}{8}$	Oxide	0.500	5	90	6	8	1,140	7,000	3.0
							135	9	8	1,600	5,000	7.0
UX-171	Large Std.	4 $\frac{1}{8}$	1 $\frac{3}{8}$	Thor.	0.500	5	90	16 $\frac{1}{2}$	3	1,250	2,400	10
UX-120	Small Std.	4 $\frac{1}{8}$	1 $\frac{3}{8}$	Thor.	0.125	3	180	40 $\frac{1}{2}$	3	1,500	2,000	20
UX-210	Large Std.	5 $\frac{1}{8}$	2 $\frac{1}{8}$	Thor Tungs.	1.250	7.5	425	35	8	1,600	5,000	18

SYMBOLS PECULIAR TO RADIO USAGE		
<p>CRYSTAL DETECTOR</p> 	<p>ELECTRON TUBE THREE ELEMENT (TRIODE)</p> 	<p>SPARK GAP QUENCHED</p> 
<p>ELECTROLYTIC RECTIFIER</p> 	<p>ELECTRON TUBE TWO ELEMENT (DIODE)</p> 	<p>ELECTROLYTIC DETECTOR</p> 
<p>SPARK GAP ROTARY, NON-SYNCHRONOUS</p> 	<p>SPARK GAP PLAIN, OPEN TYPE</p> 	<p>SPARK GAP ROTARY, SYNCHRONOUS</p> 
HEADPHONE, SPEAKER AND MICROPHONE SYMBOLS		
<p>HEADPHONES HIGH RESISTANCE SUCH AS USED IN RADIO</p> 	<p>LOUD SPEAKER</p> 	<p>TELEPHONE RECEIVER SINGLE, LOW RESISTANCE UNIT</p> 
	<p>MICROPHONE</p> 	

As the three fundamental characteristics of electrical circuits are inductance, capacitance, and resistance, the symbols for these electrical quantities are called "Unit Symbols," and all others are called "Composite Symbols."

The fundamental symbols for inductance, capacity and resistance are as follows:

INDUCTANCE



CAPACITANCE



RESISTANCE



INDUCTANCE SYMBOLS

INDUCTOR OR
INDUCTANCE
FIXED
AIR CORE



INDUCTOR OR
INDUCTANCE
VARIABLE

AIR CORE
Continuously variable by
"variometer" principle

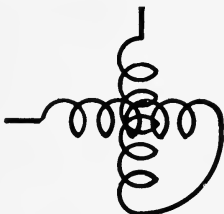

INDUCTOR
SHIELDED



INDUCTOR,
MUTUAL
FIXED MUTUAL
INDUCTANCE

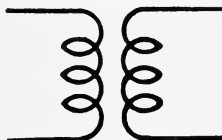

INDUCTOR OR
INDUCTANCE
VARIABLE

AIR CORE
Continuously variable



INDUCTOR OR
INDUCTANCE
VARIABLE.

AIR CORE
Adjustable by taps or steps



INDUCTOR,
MUTUAL,
VARIABLE
VARIABLE MUTUAL
INDUCTANCE

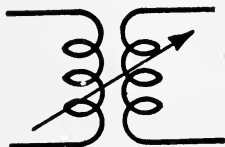

INDUCTOR,
MUTUAL
VARIABLE MUTUAL
INDUCTANCE MOVING
COIL INDICATED

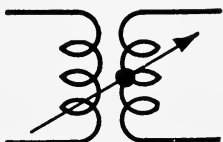

INDUCTOR OR
INDUCTANCE

IRON CORE
Commonly called a "choke coil." (Note: The representation for iron core is the same for all inductance symbols, i. e., for fixed or adjustable inductance.)



CAPACITANCE SYMBOLS

CAPACITOR OR CAPACITANCE
FIXED



CAPACITOR OR CAPACITANCE

VARIABLE, MOVING PLATE INDICATED



CAPACITOR OR CAPACITANCE
SHIELDED

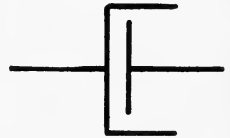

CAPACITOR OR CAPACITANCE
VARIABLE



RESISTANCE SYMBOLS

RESISTOR OR RESISTANCE
FIXED



RESISTOR OR RESISTANCE
ADJUSTABLE BY TAPS OR STEPS



RESISTOR OR RESISTANCE
CONTINUOUSLY VARIABLE

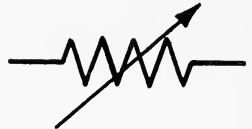

AERIAL AND GROUND SYMBOLS

AERIAL OR ANTENNA

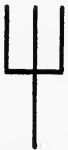

COUNTERFOISE



GROUND



COIL ANTENNA



WIRING SYMBOLS

WIRES
ELECTRICALLY
CONNECTED



WIRES NOT
ELECTRICALLY
CONNECTED
CROSS OVER



MEASURING INSTRUMENT SYMBOLS

AMMETER

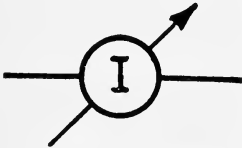

GALVANOMETER

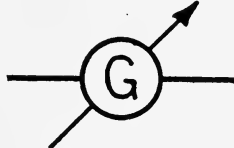

FREQUENCY
METER

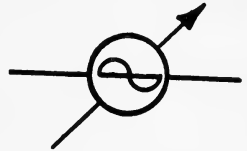

VOLTMETER

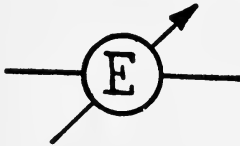

WATTMETER

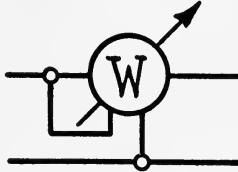

WAVE METER

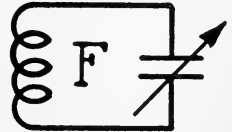

SYMBOLS FOR SWITCHES, FUSES, ETC.

SELECTOR OR
TAP SWITCH



REVERSING
SWITCH

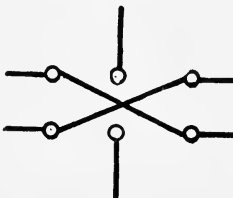

KNIFE SWITCH
SINGLE POLE, DOUBLE
THROW



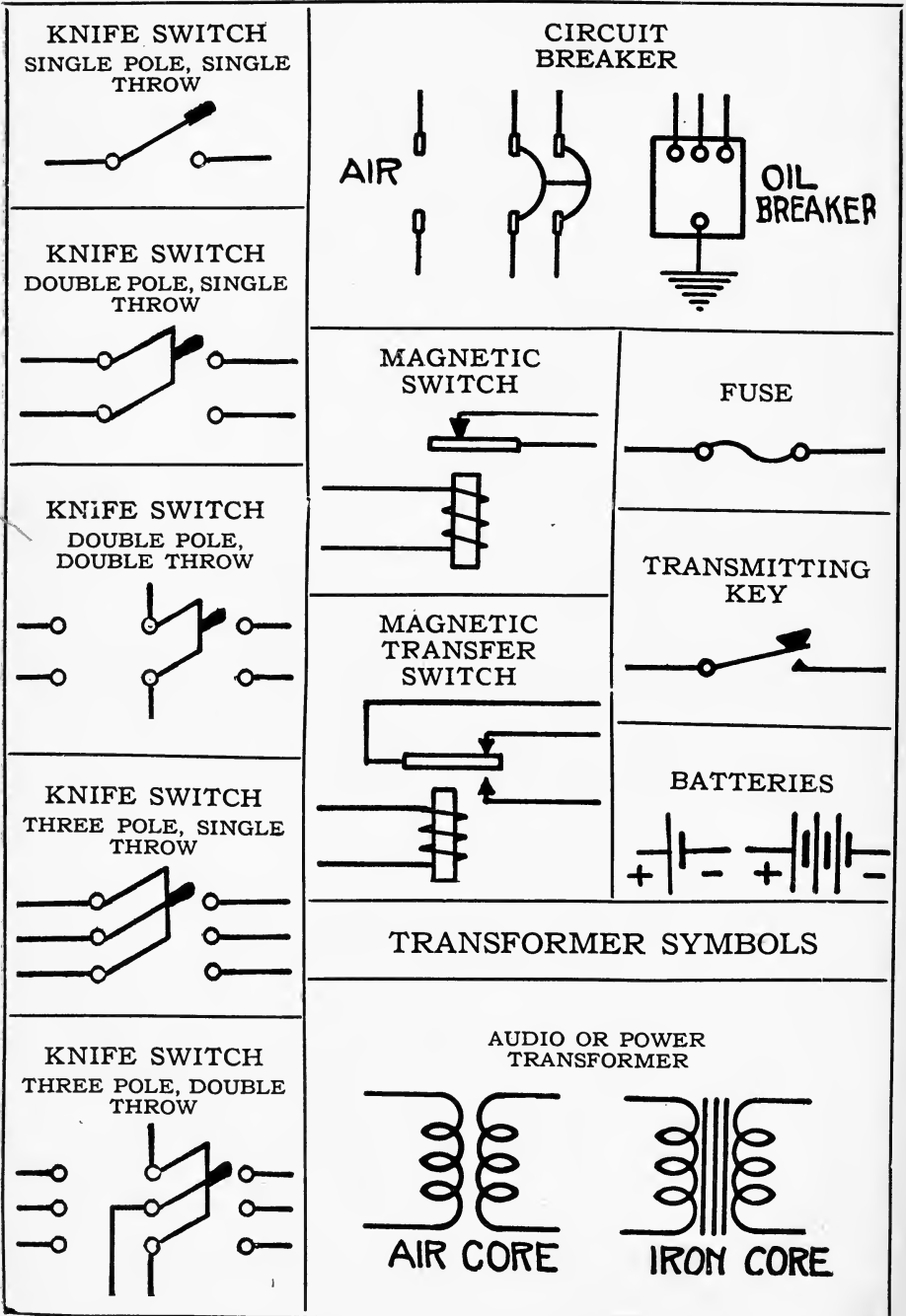

MISCELLANEOUS SYMBOLS

THERMO-ELEMENT

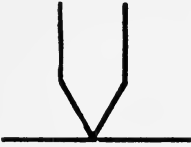

ELECTRIC BELL



INCANDESCENT LAMPS

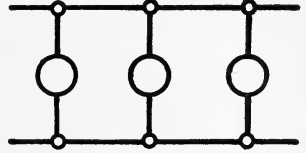

ARC

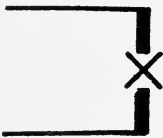

PIEZO-ELECTRIC CRYSTAL

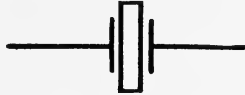

TELEPHONE (or Radio) PLUG



BUZZER

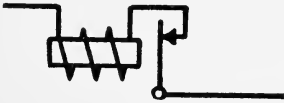

JACK

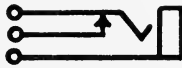

AMMETER SHUNT

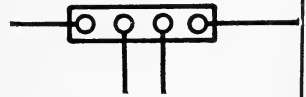

LIGHTNING ARRESTER



SERVICING BROADCAST RECEIVERS

Just the same as any other mechanical or electrical device, Broadcast Receivers do fail at times. These failures, some trivial and some more serious, all center around the same fundamentals for all types of receivers. When a receiver refuses to work properly, the first inclination of the amateur owner is to take the receiver apart. The proper procedure is to find the exact location of the trouble and then repair that particular part, not disturbing any other part of the receiver.

The following simple tests apply to most receivers. Suppose the connections are all made, the current turned on, etc., ready for operation.

1. Removing the Speaker Plug or Plug tips from the receiver should produce a click in the speaker; if not, the audio B Battery circuit is open.

2. Tapping the Detector tube lightly should produce a microphonic noise in the loud speaker, this indicates that the audio amplifier is functioning; if not the trouble must be due to one or more of the audio amplifier stages.

3. When the audio amplifier has three or four stages, the loud speaker can be connected between the plate of any of the audio tubes and audio battery B plus point to disconnect one or more of the stages. By the process of elimination the defective stage can be located.

4. A jumper wire can be connected from one socket to the next to cut out an audio stage tube to see if it is causing trouble or not, connecting the wire plate to plate (both plates must be fed from the same B battery voltage value).

5. A pair of telephones can be connected across the primary of the first audio transformer, this gives a direct test on the radio frequency amplifier and detector, without any audio amplification.

6. A phonograph pickup connected across the primary of the first audio transformer would be suitable to use to test the audio amplifier.

7. By connecting the antenna directly to the plate post of the last radio frequency stage transformer, all the radio frequency stages are cut out and the detector transformer stage is working alone. By securing a signal with tuning, the antenna can then be moved to the next radio frequency tube plate contact, bring one stage of radio frequency amplification into play. Then retuning, the same signal is obtained again. This process is carried out until all the radio frequency stages are tested. Failure of any one stage to pass a signal

through would indicate the trouble was located in that stage. Following the above system it would be possible for a service man with little knowledge of radio to exactly locate any possible trouble immediately, and without any measuring devices.

Failure of a receiver to operate may be due to one of the following reasons:

- Lack of operating experiences on the part of the user.
- Location
- Defective Accessories
- Open Circuit
- Short Circuit
- High Resistance Connection

Lack of operating experience may be the result of not following the instructions or the instructions may not be clear to the user. It should be remembered that a receiver shipped by a reputable manufacturer is carefully tested before shipment. Aside from damage in transit, which is unusual, the receiver should give good operation if the instructions are carefully followed and the proper accessories used. It is very often the case that unsatisfactory operation is due to using poor accessories or defective tubes. The fact that certain tubes work in one set does not mean that they are suitable for another set, which is designed for other certain tubes.

A new owner of a powerful receiver very often has the idea that extreme distance should be obtained immediately after the receiver is set up in operation. One must become familiar with the receiver and learn how to make the adjustments to secure maximum results and this requires skill and practice. A good radio operator could not tell a new owner how to tune to secure maximum results any more than Fritz Kriesler could tell him how to play a violin in three lessons. The owners of broadcast receivers who obtain the best results and most enjoyment out of their sets, are the ones who acquire tuning skill and this takes long practice.

Some people are more adapted to acquiring this skill than others. There have been cases where the son of the family, fourteen years old has been able to tune in dozens of real distant stations, while the father cannot duplicate the results on the same set, probably due to a lack of patience.

Location has considerable bearing on the results obtained. The writer has used the same portable Phantom in many locations in the United States and Canada, always with the same tubes. In New

York City, it is unusual to receive Pittsburgh in the daytime, yet in Pittsburgh, New York City stations are received almost like locals. From New York City it is very unusual to receive any of the Canadian stations in the daytime, yet 450 miles north of New York, located in the northern part of Quebec, the New York stations are received with great volume in the daytime. Along the same lines, leaving New York City and moving out to Long Island toward Southampton or Montauk Point, a daylight range as far as Chicago is obtained with fair regularity. Down in Florida, excellent results were obtained using the Phantom on a loop, the receiver being located in the rear compartment of an automobile, night reception being obtained from all over the states. In New York City at some locations WJZ is the stronger while at other points in the city a few miles away WEAJ is by far the stronger station. In most of the locations in New York City, distant reception can be obtained while the locals are operating, yet there are other locations where it is almost impossible to secure distant reception even with the locals off the air.

Under defective accessories are included tubes, batteries, loud speakers, antenna and ground installations as well as improper battery connections. Tubes tested and shipped with a receiver may fail due to the fragility of their construction, or the tube may have been perfect when tested and fail after a short period of use. The tubes may not be suited for the particular socket in which they are inserted. A UX200 detector inserted in any socket but the detector socket, or if in the detector socket and having more than 25 volts applied to the plate, would block the entire receiver. The loud speaker may not have the proper electrical characteristics to match the receiver. The old type speakers having speaker units and horns are entirely unsuitable for receivers that produce great volume. A good many Cone speakers will not handle the volume of a powerful receiver, the movement of the speaker unit armature is so great that the armature strikes the magnet pole pieces, causing decided distortion.

Open circuits are generally found in the movable connections of the receiver, such as pig-tail connectors, loop leads, loud speaker leads, cable connectors, or any other lead that is subject to movement or vibration. Connections soldered with acid will eventually corrode until they are open circuited. Other open circuits may occur due to a tube making poor contact in the socket contacts, or a removable transformer base making poor contact in the socket. In removable type transformers, the leads are sometimes broken from the transformer to the base due to improper handling.

Short circuits in a receiver may be due to several causes. For example if the filament of a tube breaks and falls, it may cause a circuit from the plate to filament or plate to grid, which would apply the plate voltage through the grid circuits, burning out transformers. A tube that is roughly jarred, may have the grid touching the plate, which would cause damage to the receiver when inserted, also running down the B batteries very quickly. When a B eliminator is used, the filaments should not be turned off until the eliminator is first shut off otherwise the B eliminator voltage may raise to a high value which would puncture and short circuit the by-pass condensers. Small condensers are best tested to see if any current will pass through them, if they pass current they have broken down and are useless. When testing condensers the leads should be removed, as the condenser may have an inductance in parallel to it which would show a short circuit in test.

Large by-pass condenser 1/10 MF or larger are best tested by charging. That is a potential of 90 volts or more is applied to the terminals of the condenser for a moment, then by removing the leads and shorting the condenser terminals with a piece of wire, a short fat spark should be noted, this is the charge in the condenser being discharged, and indicates that the condenser is satisfactory.

High resistance connections may be due to corrosion of contacts. This type of defect is the most difficult to locate. Such connections may also be due to poor grid leaks that have changed in value with use, not only the grid leaks for detector, but the grid leaks used in resistance coupled audio amplifiers.

A set which has been in operation only a short period and fails usually has one of the following defects: ,

- A defective tube
- Defective Battery or battery connection
- Loud Speaker connection loose in plug
- Burnt out transformer

If the set has been in operation a month or six weeks, and trouble is reported, it is usually due to weakened batteries or weakened tubes. If the set has been in operation nearly a year and trouble is reported it might be due to a great variety of reasons. In order to determine the reason, as much information as possible should be supplied. On the Transoceanic Phantom a 9 point meter switch is provided, which reads the A, B and C voltages, if the customer gives these, his trouble

can usually be located immediately. Likewise if the receiver is not equipped with a voltmeter the different battery voltages can be recorded with an external meter and the values sent to the manufacturer.

A set that develops noise and scratching noises when tuning usually has a worn moving part such as a variable condenser bearing, rheostat contact, etc. A loose antenna or ground connection would give the same result. Any unusual noise heard may be within the set or collected by the antenna, the test is to remove the antenna connection, if the noise stops, it is being collected by the antenna and not due to the receiver. If the noise is serious it should be traced down and found. It may be due to an Oil Burner, Delco Light System, Electrical devices of all types, Vibrating Battery Chargers, X-Rays, Moving Picture Machines, etc., devices are available to attach to these to prevent such disturbances. Leaky Transformers and Insulators on High Tension lines and Electric Railway power lines are some of the worst offenders, their disturbances are more noticeable during damp weather.

Complaints are made that a great deal of noise is obtained with distant reception. Holding this distant station until it signs off it will be noted that 90% of the noise will disappear when the station signs off. It seems that the background disturbances connected with a broadcast program have not yet been eliminated. It may be that the carrier wave is further modulated after leaving the transmitter antenna, this seems possible because some telegraph signals seem to follow certain broadcast carrier waves when they are in operation. For example, it was noticed that the Key West telegraph station could be heard on a broadcast receiver while the Miami broadcaster was working, but not otherwise.

If the volume of a signal gradually increases and decreases it is usually due to fading. If the signal stops and starts with no change in volume, it is due to a loose connection, either to the batteries or possibly the antenna lead-in being loose.

Lack of volume may be due to any of the following causes:

- Inexperience, lack of tuning knowledge
- Defective tubes or batteries
- Reversed A battery connection
- Poor antenna location or installation
- Defective ground connection
- Defective loud speaker

Broad tuning is usually due to an excessively long antenna or an antenna having extremely high capacity, the latter would be true when the antenna was close to the roof or side of a steel frame building.

The tuning can be sharpened up considerably by using an antenna series condenser. A variable condenser having a maximum capacity of .0005 MF can be inserted in series with the antenna and varied to a value where the desired selectivity is obtained.

If the antenna is located near power lines, it should be preferably at right angles to the power lines to pick up a minimum of disturbance. Some receivers seem to work best during damp weather, this would indicate that the dampness increased the value of the ground connection. On the other hand if the receiver worked best in dry weather it would indicate that the antenna insulators were at fault and were ineffective during rainy weather.

A loud speaker connected with the wrong polarity to a receiver (without a filter circuit) will in due course become demagnetized and give poor volume and quality.

A howl set up in the loud speaker, starting at a low volume and ending in a continuous howl, is due to the microphonic action of the detector or audio amplifier tubes. This can be eliminated by moving the speaker a considerable distance from the receiver, or padding the detector and audio amplifier tubes with felt to deaden the vibrations. This condition is most evident when the receiver is operated to maximum amplification.

Distortion is usually due to improper plate or bias battery voltages. In a resistance coupled amplifier it may be due to the wrong value of grid leak or plate resistors, different values should be tried. Distortion will occur if the audio tubes are overloaded, there is, of course, a limit to the volume that the power audio tube will handle without distortion. Loud speakers can be damaged by excessive volume and have to be repaired before the distortion is entirely eliminated. The performance of the loud speaker is best checked by substituting another speaker temporarily.

Excessive oscillations or regeneration will cause distortion. This may be due to the neutralizing system becoming unbalanced. Reducing the radio frequency plate voltage should cure excessive oscillations if none of the receiver parts have become unbalanced. On the other hand if the sensitivity of the radio frequency amplifier is low, it may be increased by increasing the radio frequency plate voltage. The total

sensitivity of the radio frequency amplifier depends a whole lot upon the radio frequency tubes used. These tubes should be selected in the receiver while receiving a weak signal and not selected in a tube tester. Where a single control receiver is used, the capacity of the tube may have as much bearing as the amplification factor or performance of the tube as a radio frequency amplifier.

A ringing sound when touching the set or table on which the set is mounted, is due to the microphonic action of the detector or audio tubes. This can be eliminated by using tubes which are as non-microphonic as possible or padding the tubes with felt. A continual frying noise may most likely be due to a worn out or defective battery. Placing a pair of telephones across a good battery, only one click is heard when making or breaking the circuit, if the battery is low or defective a frying noise will be heard in the phones.

“Motor Boating” or Putt, Putt noise is caused by an open grid circuit in the case of battery operated sets. In sets using an eliminator for the B voltage it may be due to an insufficient current capacity for the set operated. This can be cured by providing an additional reservoir condenser of 8 MF across the extreme B plus and minus terminals. If an eliminator is used in connection with a resistance coupled audio amplifier the plate resistors may have to be higher in value and the grid resistors lower in value than when operating the set on batteries.

When jarring the receiver the signal starts and stops it must be due to a loose connection, either in the wiring, tube contacts, pig-tail connectors, etc. Filament voltage varying up and down may be due to a defective filament switch where the contact is not complete, this can be checked by short circuiting the filament switch and noting if the current is steady.

Variable carbon resistors used in eliminators fail when subject to overloads or when used to obtain too high a reduction in voltage. A defective resistor of this type will cause frying noise and fluctuating supply voltage. It can be checked by short circuiting it out of circuit or by shunting it with another similar resistor.

In B eliminators, no B voltage may be due to a defective rectifier tube. The fact that the rectifier tube lights does not indicate that it is functioning. No B voltage may also be due to a shorted filter condenser, open filter choke or open output resistor.

Abnormally low B voltage may also be due to the rectifier tube being defective, or to Speaker filter condenser shorted, speaker filter

impedance grounded, amplifier grid circuit open, biasing resistor shorted, no amplifier grid bias, defective eliminator power transformer. Abnormally high B voltage is usually due to a shorted filter choke or amplifier plate circuit open.

Incorrect voltages at the output taps may be due to a shorted filter choke, broken down By Pass condensers in the receiver, output resistance open or shorted or regulating resistors burnt out.

If the power amplifier transformer overheats it may be due to an excessive load at the output, defective tube, shorted filter condenser, or shorted turns in the power transformer.

Excessive hum from the eliminator would be due to a shorted filter choke, open filter condenser, amplifier filament return tap incorrect or defective ground connection on filter condensers.

The lack of audio output may be due to a defective audio transformer, filter condenser shorted, amplifier grid or plate circuit open or a defective amplifier tube.

Low distorted audio output may be due to a filter condenser shorted, speaker filter condenser shorted, grid circuit open on bias side of audio transformer, biasing resistor shorted.

Lack of distance reception may be due to too short an antenna. Nothing helps distance reception as much as a good high antenna. Of course a long and high antenna will tune broad on an ordinary receiver. To secure best results it is possible to have an average antenna of say 150 feet for ordinary work and an antenna 350 to 450 feet long for long range work.

For the reception of wavelengths from 500 to 3600 meters the antenna must be much larger than that used for 200 to 500 meters. To receive the European stations operating on 1000 to 2600 meters from this country the receiving antenna to be ideal should be 1000 to 2000 feet long. Such an antenna is impossible in most city locations, but in the country the experimenter that can erect this type of antenna will be well rewarded with his experiments. Such an antenna is also suitable for long range reception of signals on all the lower wavelengths, using the antenna as a wave antenna.

In conclusion, in cases of trouble, do not blame the set until you investigate the

Aerial—(a) Grounded; (b) touching foreign objects; (c) connections corroded; (d) lead in broken inside insulation.

Lightning Arrester—(a) Leaky or (b) short-circuited.

Ground Connection—(a) Wire broken inside insulation; (b) corroded at connection to pipe or other ground; (c) inefficient source of ground (too dry earth, &c.).

"A" Battery—(a) Discharged or "run down." (Test with hydrometer.) This is indicated by gradual dying out of signal strength during reception. Turning the set off for a time will permit the battery to recuperate slightly so that reception may be prolonged, but the battery should be recharged as soon as possible, as it is injurious to the plates to attempt to draw current from the battery when run down. (b) Corroded connections at terminals of "A" battery cause various peculiar effects in reception. It may result in weak reception, noisy reception, or irregular reception, that is weak for a time, then suddenly strong, followed by a period of weak reception. Terminals should be scraped bright and then coated with vaseline to prevent further corrosion. (c) If an "A" battery eliminator is used, the trouble may be either in the charging device or the small battery, which is the current source of the eliminator.

"B" Battery—(a) Dry B batteries when run down cause reception to be weak and noisy, usually a sort of bubbling or hissing noise. If the B unit supplying current to the detector is run down the noise may be a steady whistle. It is advisable to replace a 45-volt unit when it has dropped to 34 volts. (b) A frequent cause of poor reception is improper connection of the cable wires of set to the various B battery terminals. (c) Storage B batteries also have their own peculiarities. Sometimes the voltmeter test may show them O. K., but a hydrometer test will indicate one or more run down cells, which will greatly interfere with reception. High resistance connections between cells and corroded terminals also occasionally cause trouble.

Tubes—Defective tubes are one of the most common causes of trouble in reception. A tube may light perfectly and yet be "dead," so far as reception is concerned. Tubes also become weak or lose sensitivity after a period of use. Occasionally, due to poor interior construction, the internal elements of a tube will touch one another, causing a short circuit. If the grid and plate of a tube in a set come

in contact while the set is connected up for use, the plate current will pass through the grid circuit, usually damaging or burning out the "grid resistance unit." If this occurs the filament of the tube is involved, resulting in it "burning out" and rendering the tube unfit for further use. If the other tubes are in the set, they too will sometimes burn out.

There are also cases where this short circuit of the internal elements is only momentary, due to a slight shock or jar to the tube. In this case the damage may be only partial or complete burning out of a grid resistance unit or choke coil. The tube will then function properly but may again cause similar trouble at any time without warning. It is therefore very important that any tube which is suspected of having this defect be located and replaced before further damage is done.

For best results use standard tubes of established national reputation. Where some tubes in a set are found by test to be less sensitive than others, these should be placed in the audio frequency sockets.

Remember: It should be borne in mind that the noise in the loudspeaker does not necessarily imply a plot on the part of the power supply. Radio instruments are made to deal with minute energies and consequently are of delicate construction.

Many an investigating fist thrust inside a receiver cabinet has bent the plates of a variable condenser, and a variable condenser with vanes that touch and spark is quite as potent a source of trouble as any spark that ever wandered off a trolley line.

Batteries produce noises of their own. Corroded terminals in jacks and battery clips, corroded socket contacts and tube prongs are likely to become vocal if neglected. An open circuit in the audio end will produce a fine imitation of a 60 cycle hum.

A defective grid leak will fry energetically. Loose connections in the auxiliary equipment of a receiving set may prove quite as obnoxious as loose connections in the house wiring.

The best radio receiver ever produced is not proof against rough handling or neglect. Therefore, in the search for the cause of interference, one might as well start off by making sure that the noise is not a home made one.

Quality Reproduction

These two words sum up the aim of any radio receiving engineer, for radio has now passed out of its experimental stage and is now regarded by the average listener as an instrument that will faithfully reproduce both speech and music. To promote the present day efficiency of broadcast reception the General Radio Company has done much in scientific research and development work.

The General Radio Company was also the first concern to supply closed core audio frequency amplifying transformers and has been foremost in the development of audio frequency transformers to accompany the great improvements in broadcasting station quality of transmission and improved loudspeaker reproduction.

In a search for an amplifier combination which would give the maximum quality and volume, the push-pull method has proved particularly satisfactory. The Type 441 Push-Pull amplifier illustrated is a completely wired unit and consists of two high quality push-pull transformers with the necessary sockets and resistances mounted on a brass base-board.

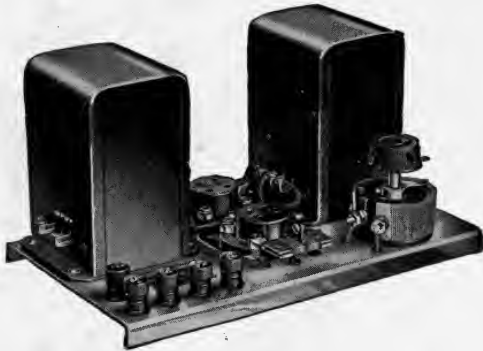

Type 441 Push-Pull Amplifier

PRICE - - - \$20.00

Licensed by the Radio Corporation of America for radio amateur, experimental, and broadcast reception only, and under the terms of the R. C. A. license, the unit may be sold only with tubes.

GENERAL RADIO CO. ∴ Cambridge, Mass.

GENERAL RADIO
LABORATORY INSTRUMENTS
PARTS *and* ACCESSORIES





