

GIFT OF
Dean Frank H. Probert

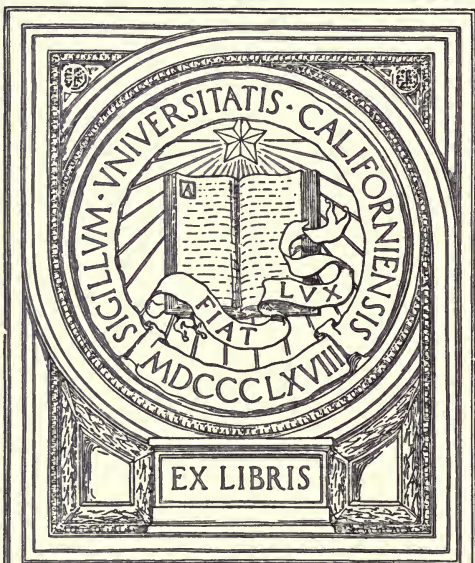

Mining Dept.

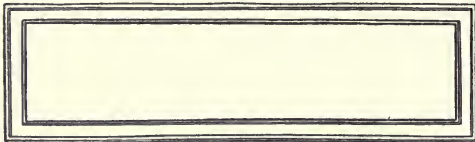

Frank Holman Robert

MORE RECENT CYANIDE PRACTICE

EDITED
BY
H. FOSTER BAIN

SECOND EDITION

PUBLISHED BY THE
MINING AND SCIENTIFIC PRESS
SAN FRANCISCO
1910

TN 767
B3
1910
cop. 3
MINING
DEPT.

GIFT OF
DEAN FRANK H PROBERT

MINING DEPT.

COPYRIGHT, 1910,
BY
MINING AND SCIENTIFIC PRESS.

TO THE
LIBRARY OF THE
MINING DEPARTMENT

PREFACE

The success which attended the publication of 'Recent Cyanide Practice,' edited by Mr. T. A. Rickard, and printed in 1907, together with repeated calls for a volume covering in the same manner still later developments in cyanidation, has led to the compilation of this book. In it the development of cyanidation from October 1907 to July 1910 is reflected in articles contributed originally to the *Mining and Scientific Press*. The individual articles cover a wide range and illustrate the development both of theory and practice in the period covered. They have come from all parts of the world and the contributors include the leaders in the application of cyanide to metallurgy. No attempt has been made to harmonize conflicting views, and as little change as possible has been made in the original wording of the authors. The necessary limit to the size of the volume has precluded reprinting of many other worthy and interesting papers, for which readers must refer to the files of the *Mining and Scientific Press*. In making the selection of material I have had the valued assistance of Mr. Bertram Hunt.

H. FOSTER BAIN.
Editor.

San Francisco, August 15, 1910.



TABLE OF CONTENTS

	Page.
The Desert Mill.....	<i>A. R. Parsons</i> 9
Economy of Power in Crushing Ore.....	<i>Ernest A. Hersham</i> 20
The Mechanics of Ore-Crushing.....	<i>Courtenay De Kalb</i> 35
Sliming Ore for Cyanidation.....	<i>Mark R. Lamb</i> 37
Cyanidation in Nevada.....	<i>R. Stuart Browne, Edgar A. Collins, Lochiel M. King, Bertram Hunt, A. G. Kirby</i> 39
Cyanidation with the Brown Vat.....	<i>Francisco Narvaez</i> 60
Cyanidation of Ore Containing Both Coarse and Fine Gold.....	<i>Viator, Philip Argall, C. W. Van Law, Edward H. Nutter, Walter L. Reid, E. P. Kennedy, E. A. H. Tays, Edwin C. Holden, Geo. A. Packard, Jas. S. C. Wells, W. A. Caldecott, E. M. Hamilton</i> 63
The Burt Rapid Cyanide Filter.....	<i>E. Burt</i> 76
Slime Treatment at Kalgoorlie.....	<i>M. W. von Bernewitz</i> 82
The Roasting of Telluride Ores....	<i>T. T. Read, R. L. Mack, G. H. Scibird</i> 84
A Conical Tube-Mill.....	<i>H. W. Hardinge</i> 105
Tube-Mill Lining.....	<i>H. W. Hardinge, C. E. Rhodes, Blaisdell Company</i> 108
Tube-Mill Lining, Slime-Filters, and Patents.....	<i>Arthur De Wint Foote</i> 111
Progress in the Treatment of Gold Ore.....	<i>Alfred James</i> 114
The Dos Estrellas Mill.....	<i>An Occasional Contributor</i> 118
The El Oro Tube-Mill Lining.....	<i>Joseph Rodney Brown</i> 120
Crushing Ore.....	<i>M. P. Boss</i> 122
Mill-Tests	<i>Mark R. Lamb</i> 136
Tube-Mill Lining.....	<i>H. E. West, H. W. Hardinge</i> 137
Sodium Cyanide.....	<i>E. A. Holbrook</i> 142
Cyaniding Mill-Pulp After Amalgamation.....	<i>Cyril E. Parsons</i> 142
Recent Cyanide Mill in Mexico.....	143
The Ridgway Filter.....	<i>Mark R. Lamb</i> 145
Submerged Facts and Filters.....	<i>G. A. Duncan</i> 146
Cyanide Costs....	<i>W. A. Moulton, A. R. Parsons, A. Del Mar, C. E. Rhodes</i> 148
Goldfield, Nevada.....	<i>T. A. Rickard</i> 151
Milling and Cyanide Practice, San Prospero Mill Guanajuato.....	<i>J. S. Butler, Bernard MacDonald</i> 158
Yellow Jacket Mill, Comstock Lode.....	<i>Whitman Symmes</i> 165
Cyanidation in Mexico.....	<i>Francis J. Hobson, Bertram Hunt</i> 167
Cyanidation of Silver Ores.....	<i>W. J. Sharwood, W. A. Caldecott, Theo. P. Holt</i> 178
Treatment of a Concentrate-Slime.....	<i>A. E. Drucker</i> 190
Continuous Slime Filter.....	<i>Robert Schorr, E. N. Walker</i> 194
Milling Practice in Nevada Goldfield Reduction Works.....	<i>E. S. Leaver</i> 198
Milling Plant of the Montana Tonopah Mining Company.....	<i>G. H. Rotherham</i> 201
Homestake Slime-Plant Costs.....	<i>C. W. Merrill</i> 209
Agitation by Compressed Air.....	<i>F. C. Brown</i> 210
Continuous Vacuum-Filter Machine.....	<i>Bertram Hunt</i> 216
Recent Cyanide Practice in Korea.....	<i>A. E. Drucker</i> 220
Bromo-Cyaniding of Gold Ores.....	<i>E. W. Nardin</i> 226

TABLE OF CONTENTS

	Page.
Home-Made Cyanide Plant.....	W. F. Boericke, B. L. Eastman 231
Progress in Cyanidation.....	Alfred James, Francisco Narvaez 233
Lead Acetate in Cyanidation.....	C. M. Eye 246
Loss of Cyanide.....	Dana G. Putnam 247
Treatment of the Gold and Silver Precipitate at Dos Estrellas.....	Walter Neal 248
Chemistry of the Bromo-Cyanogen Process.....	S. H. Worrell 250
Cyaniding Silver Ore in Honduras.....	George E. Driscoll 253
Cyanidation at Mercur, Utah.....	Leroy A. Palmer 256
Mines and Plants of the Pittsburg Silver Peak.....	Henry Hanson 263
Short-Zinc.....	F. L. Bosqui, H. T. Willis, Bertram Hunt, R. Stuart Browne 273
Agitator for Cyanide Tests.....	G. H. Clevenger 278
Vacuum Slime-Filters at Goldfield.....	Alfred Merritt Smith 279
Cyanidation of Silver Ores.....	Theo. P. Holt 282
Brown Type of Laboratory Agitator.....	T. S. Lawlor 290
All-Sliming.....	E. M. Hamilton, P. R. Whitman, Edgar A. Collins, Huxley St. J. Brooks 293
Boston-Sunshine Mill.....	G. W. Wood 303
Simmer Deep and Jupiter Reduction Works.....	J. E. Thomas 305
Researches Upon Cripple Creek Telluride Ores.....	312
Researches Upon Cripple Creek Telluride Ores.....	Bertram Hunt 316
Cyanide Notes.....	M. W. von Bernewitz 316
Cyaniding Concentrate at Taracol, Korea.....	J. D. Hubbard 318
Slime.....	Edward Parrish 323
Assay of Cyanide Precipitate.....	Frank A. Bird 326
Continuous Collection of Sand for Cyaniding.....	W. A. Caldecott 329
Oliver Continuous Filter.....	A. H. Martin 333
Graphite—An Obstacle to Good Cyaniding.....	M. W. von Bernewitz, Donald F. Foster 336
Tests on Acid Regeneration of Cyanide Solutions.....	R. P. Wheelock 341
Regenerating Copper Cyanide Solution.....	Isaac Anderson, R. P. Wheelock 352
Pressure Filtration.....	Ernest J. Sweetland 356
James' Annual Cyanide Letter.....	Alfred James, E. M. Hamilton, John M. Nicol, Ralph Nichols, M. W. von Bernewitz 362
Silver on Filter Leaves.....	Donald F. Irvin 378
Recent Milling Practice.....	A. E. Drucker 378
Cyanidation of Silver Ores.....	Lloyd M. Kniffin 382
Cyanidation of Concentrate.....	A. E. Drucker 384
Diaphragm Cones and Tube-Milling.....	Walter Neal 389
Improvements in the Cyanide Process.....	Bernard MacDonald 396
Methods of Pulp-Agitation.....	Lloyd M. Kniffin 401
Assay of Gold-Silver Cyanide Solutions.....	Theo. P. Holt 403

THE DESERT MILL.

By A. R. PARSONS

(October 19, 1907)

The 100-stamp mill and power-plant of the Desert Power & Mill Co., operated by the Tonopah Mining Co. of Nevada for the purpose of milling the ore produced from its Tonopah mines, is situated at Millers, Nevada, a station on the Tonopah & Goldfield railroad 13 miles west of Tonopah.

The entire installation, both mill and power-plant, was made by Chas. C. Moore & Co., of San Francisco, to whom a contract for the work was given. A little over one year was required to complete the mill. Mr. John H. Hopps of San Francisco acted as consulting engineer.

The power-plant contains four Babcock & Wilcox water-tube boilers of the vertical header type, provided with superheaters, set in batteries of two each. Each boiler contains 2036 sq. ft. of heating surface. The boilers are arranged for firing with either coal or oil; the Moore oil-burning apparatus is used. Natural draft is obtained by means of a 66-in. steel stack 150 ft. high. A Green fuel-economizer utilizes the flue-gases. The minor boiler-room equipment consists of two Snow duplex boiler-feed pumps, Goubert feed-water heater, automatic relief-valves, stop and check-valves, damper-regulator, hot well, steam-traps, feed-water meter, thermometer, etc., all of which is ample and well arranged.

There are three 14 by 28 by 30-in. horizontal cross-compound side-crank McIntosh & Seymour gridiron-valve engines, each condensing, arranged for direct connection to 250 kw., 25 cycle, 2200 volt, 150 r.p.m. alternators. There is also one 15 by 32 by 30-in. McIntosh & Seymour engine as above, directly connected to a 300-kw. alternator. All electrical equipment was furnished by the Westinghouse Electric & Manufacturing Co. The exciting current is supplied by 125-volt direct-current exciters, belted from the band-wheel of the generators.

Condensation of steam from the engines takes place in Edwards condensers, equipped with power-driven air-pumps. The circulating water for condensing is pumped, by means of 8-in. double-suction Wheeler centrifugal pumps directly connected to 40-hp. motors, to a fan-driven steel water-cooling tower. Suitable switchboards with generator panels and distributing boards for mine and mill are conveniently placed in the engine-room. Step-up transformers raise the voltage from 2200 to 22,000 for transmission over the 12-mile line to the hoists at the shafts in Tonopah. Step-down transformers lower the voltage at the mill from 2200 to 440, all the mill-motors being 25 cycle, 440 volt Type C.

Water for the mill and power-plant is pumped by a two-stage

vertical centrifugal pump from a well 60 ft. deep, situated 1700 ft. north of the plant.

The main mill-building, 525 by 230 ft. in extreme dimensions, is erected on ground having only a 3% slope. The crude ore from the mines is taken up an incline trestle in steel hopper-bottom 50-ton railroad-cars, in lots of seven cars, to the crusher ore-bin.

The orebodies of Tonopah are largely replacements of andesite by quartz, forming parallel or branching veins and veinlets of quite solid quartz, separated by mineralized andesite, which frequently assays well. The ore as stoped, is therefore a mixture of quartz and 'porphyry.' Some of the early barren porphyry is sorted out before the ore is sent to the mill.

The primary ore of Tonopah consists of a gangue of quartz with some sericite and adularia, with a small percentage of the carbonates of lime, magnesia, iron, and manganese; the silver is present mostly as sulphide and sulphantimonide; gold is never visible, and occurs in some form not yet determined; small amounts of pyrite and chalcoppyrite occur, with traces of lead, zinc, arsenic, selenium, and other metals.

All of the ore now being treated at the Desert mill is partly oxidized. This oxidation, however, is never complete and most of the silver is still present in the form of argentite, which is probably mixed with stephanite, but in the more oxidized phases cerargyrite (hornsilver), frequently containing iodine and bromine, is common. The carbonates of the primary ore are represented by oxides of iron and manganese, and gypsum. In the process of oxidation, a large proportion of the iron, manganese, antimony, arsenic, copper, lead, zinc, and selenium originally present, has been removed. In none of the ore, however, are the base metals present in sufficient quantity to be valuable.

A sample of rich ore from the Valley View vein analyzed by Hillebrand of the U. S. Geological Survey gave the following results:

Ag 62.54%	{	38.10 as sulphides.	Au	0.62
		24.44 as chloride, selenide,	Fe, Mn	1.46
		and alloy.	Cu, Pb, Mn	0.51
			Se, Sb, As	0.96

The ratio of silver to gold by weight in the ore treated at the mill is about 90 to 1.

The coarse-crushing and sampling department is in a separate building. The crushing plant has a capacity of 400 tons in 8 hours. Power for driving the machinery is supplied by a 125-hp. motor, and the 18-in. Robins belt-conveyor for carrying ore from the crusher-house to battery storage-bins is driven by a 15-hp. motor.

The mine-run from the bin is fed through a finger-gate to a 7½ Gates crusher, Style K. This reduces it to a maximum size of about two inches, in which condition it is elevated by means of a 26-in. steel bucket-elevator to a 48 in. by 16-ft. revolving manganese steel screen with 1¼-in holes. The oversize from the screen passes to two 4 D Gates crushers for further reduction. The product from the

smaller crushers unites with the screened product and passes through a 60-in. Snyder sampler. The reject from the sampler falls directly

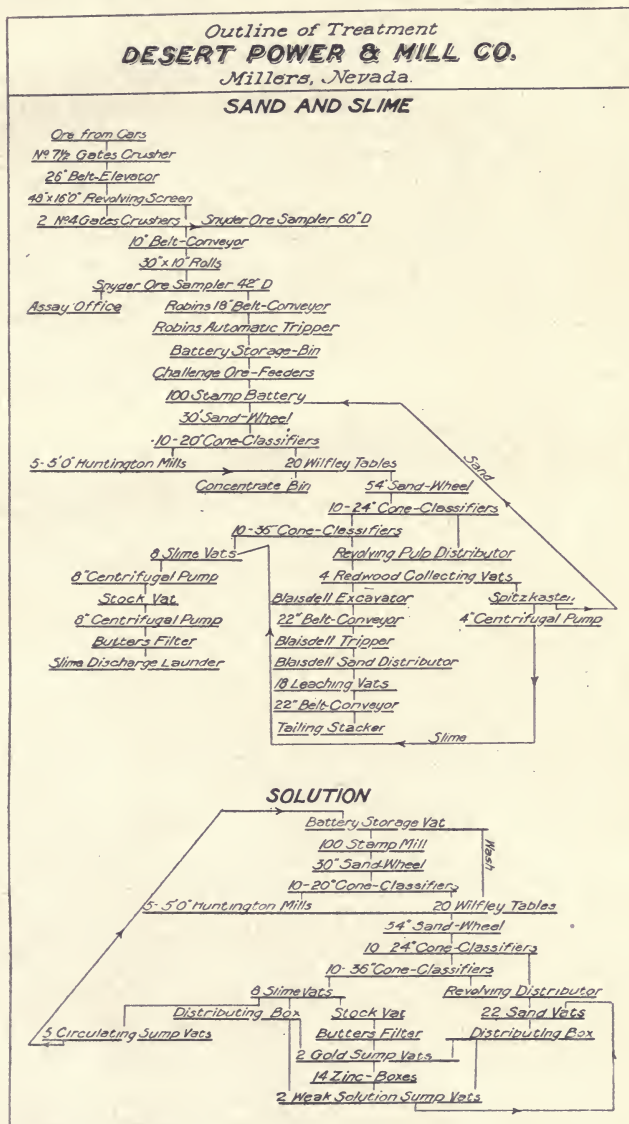

FIG. 1

upon the 18-in. conveyor. The cut-out from the sampler is elevated by a 10-in. steel bucket-elevator to a set of 30 by 10-in. rolls for fine grinding. The product from the rolls is passed through a 42-in.

Snyder sampler, the reject from which falls upon the conveyor and the 'cut-out' is taken to the assay office for further sampling and pulping. The 18-in. conveyor with troughing idlers takes the ore up a 22° incline and distributes it by an automatic tripper over the battery storage-bin, having a capacity of 1500 tons.

Rack and pinion gates regulate the ore going to the 20 Challenge feeders, supplying the 100 stamps. The mortars of the stamp-batteries are the narrow pattern, single discharge, manufactured by the Union Iron Works. They are set on substantial concrete foundations down to hardpan, rubber sheeting $\frac{1}{4}$ in. thick, being placed between the mortars and the top of the concrete. End and side-liners of malleable cast steel are used in the mortars.

Each battery of 20 stamps is driven by a 50-hp. motor, the order of dropping stamps being 1-3-5-2-4. The weight of each stamp is made up as follows: Stem, 427 lb.; tappet, 140; boss, 320; and shoe, 180 pounds.

The stamps drop 104 times per minute through a height of 6½ in. and have a duty of 4.34 tons crushing through a 12-mesh wire screen, the height of discharge being three inches.

Chrome-steel shoes and dies have been in use and cast-iron dies containing a percentage of steel are being tried with satisfactory results, a more even wear of both shoes and dies being obtained by the combination. Both shoes and dies are worn down to a thickness of less than two inches, compensation for loss of depth being made up by cast-iron false dies of varying thickness. The chrome-steel dies average 1736 stamp-hours, crushing 315 tons of ore each. The shoes average 1011 stamp-hours, crushing 285 tons each. The steel consumption of dies and shoes is respectively 6.70 and 7.60 oz. per ton of ore crushed.

The battery-crushing takes place in a solution carrying 0.15% potassium cyanide, supplied from a 188,000 gal. storage-vat that is filled by 8-in. Butters centrifugal pumps, taking their suction from sumps at the lower end of the mill. The pulp from the battery (7 of solution to 1 of ore) flows to an inside bucket-elevator wheel, 30 ft. diam., driven by a 7½-hp. motor. The wheel elevates the pulp to ten 20-in. double cone-classifiers with hydraulic upward current of cyanide solution. Sizing tests:

Screen mesh.	Battery product.	Overflow	Spigot
		from classifiers.	discharge.
	%	%	%
On 20.....	6.82	0.20	4.40
" 30.....	17.58	3.71	23.27
" 40.....	8.85	3.42	11.37
" 50.....	10.32	7.04	20.46
" 60.....	2.83	5.10	8.30
" 80.....	10.62	13.85	13.39
" 100.....	10.82	15.90	6.67
Pass 100.....	31.77	50.30	11.65

The overflow from the classifiers passes directly to ten No. 5 Wilfley concentrators. The bottom-discharge through ½-in. spigots, containing the coarse product for re-grinding, flows to five 5-ft.

Huntington mills, equipped with 30-mesh screens. Three mills ordinarily re-grind the oversize product from 80 stamps. A 50-hp. motor drives the mills and a bucket-elevator for raising the product from the mills for distribution over the ten concentrators.

The 20 Wilfley concentrators are securely anchored to a concrete floor with sufficient slope to allow drainage of any leaks or drips to the tailing-laundry beneath the level of the floor, the laundry also being made of concrete. The tables make 240 strokes ($\frac{3}{8}$ to $\frac{3}{4}$ in.) per minute, the length of stroke varying with the class of material passing over each table.

Classification and dewatering of the product to the Wilfley concentrators is obtained by a series of V-boxes receiving the pulp from the launders carrying the overflow from the 10 double-cone classifiers and re-ground product from the Huntington mills. It is intended to install additional concentrators to take the middling from the present equipment, as experiments have demonstrated that an additional saving of about 10% can be made in concentrating, at the same time removing sulphides difficult to treat in the cyanide department. At present, 90 tons of ore produce 1 ton of concentrate, averaging 4.5 oz. gold and 815 oz. silver per ton. These are partly dried to about 12% moisture by draining and vacuum applied to a small vat receiving each day's output. The concentrate is sacked each day in canvas bags and shipped to the smelter in carload lots. The recovery by concentration from March to August, this year, was 15.63% of the gold and 30.32% of the silver contents of the ore milled.

A 30-hp. motor operates the 20 Wilfley concentrators, one 4-in. Butters centrifugal pump used for pumping from wheel-pits, a Johnston vanner (used in experiments), and a small bucket elevator.

The tailing from the concentrators is elevated by means of a 54-ft. wheel to two sets of ten double-cone classifiers with hydraulic upward current of weak solution. The overflow from the upper set of 24-in. classifiers goes to the lower set 36-in. diam. The overflow slime and solution from the lower set of classifiers flows to the slime plant through a series of spitzkasten for removing the very fine sand.

The sand and solution from the $\frac{3}{8}$ -in. spigot-discharge of both sets of classifiers and spitzkasten flow through a wooden launder to a revolving wet distributor of the Butters & Mein type. This distributor is hung from a circular overhead trolley so that it can be swung to any one of four sand-collecting vats. These, as well as the 18 leaching-vats, are 33 ft. diam. by 8 ft. deep, provided with cocoa-matting and 10-oz. canvas filters laid on wooden strips, the filters being raised three inches above the bottom of the vat. The collecting-vats are provided with roller blind-overthrow gates for a further separation of sand and slime. Some sand, that overflows with the slime from these gates, is removed by a large pointed box receiving the entire overflow from collectors. The slime and solution from the pointed box are returned to the launder, going to the slime-plant by means of a 4-in. Butters centrifugal pump.

For treating the sand, a collector is filled to a depth of five feet;

this amount of packed sand, after transfer, fills a treatment vat. After a collector is filled, the distributor is swung to one of the other collectors, and the drain-valves opened for 24 hours; then a vacuum is applied to dry sufficiently to permit of excavating by means of a Blaisdell class A disc-excavator. This machine is mounted on a track and can be moved by electric motor and trolley to any sand-vat. A wrought-iron conical plug 22-in. diam. seated on a rubber gasket in a cast-iron flange in the vat is removed by means of a chain-block attached to the excavator. This leaves a clear opening from the top of the sand to the 20-in. Robins troughing-belt conveyor running below each row of vats, through which the excavator discharges the sand. It requires from two to three hours to excavate 250 tons of sand, the time depending upon the moisture in the material. The excavated sand is conveyed to a cross-conveyor at the east end of the sand-vats. The cross-conveyor, running up an incline, discharges to a conveyor of the same type running between the two rows of vats and above them, over a Blaisdell class A tripper. From the tripper, the sand falls upon the cross-belt of a Blaisdell class Z sand distributor, then on to a rapidly revolving disc with speed-regulating device by means of which the sand is distributed about the vat in a fine shower, and at the same time, thoroughly aerated.

While transferring the sand from collectors to leaching-vats, lead acetate, previously dissolved in water ($\frac{1}{2}$ lb. per ton) is allowed to drip upon the sand on the conveyor-belt and slacked lime (4 lb. per ton) is thrown into the collector in which the excavator is working, thus thoroughly mixing the lime with the sand. After transferring, a little shoveling is done to level the sand. The first leaching solution, amounting to 30 tons, is brought up to 0.25% strength by the addition of a sufficient amount of potassium cyanide solution of known strength to the vat underground treatment. This amount of strong solution is allowed to drain slowly through the partly opened drain-valves and is followed by repeated washings of weak solution from 0.15 to 0.20%, after which the charge is drained for transfer. This first treatment occupies five days, including time of the latter.

SIZING TEST ON SAND RESIDUE.

	Screen mesh.	Percentage.
Remaining on	20	0.15
“ “	30	11.64
“ “	40	13.98
“ “	50	12.31
“ “	60	10.48
“ “	80	17.54
“ “	100	12.77
Passing	100	21.05

The second treatment averages five days and consists of repeated washings of strong and weak solutions, that are drained off, and the sand transferred to another vat for the final treatment, which consists of as many washes of wash solution as there is time to apply, followed by two or three of water to displace all the solu-

tion. Then the vat is finally drained by vacuum for discharging from the plant. All charges of solution are allowed to disappear

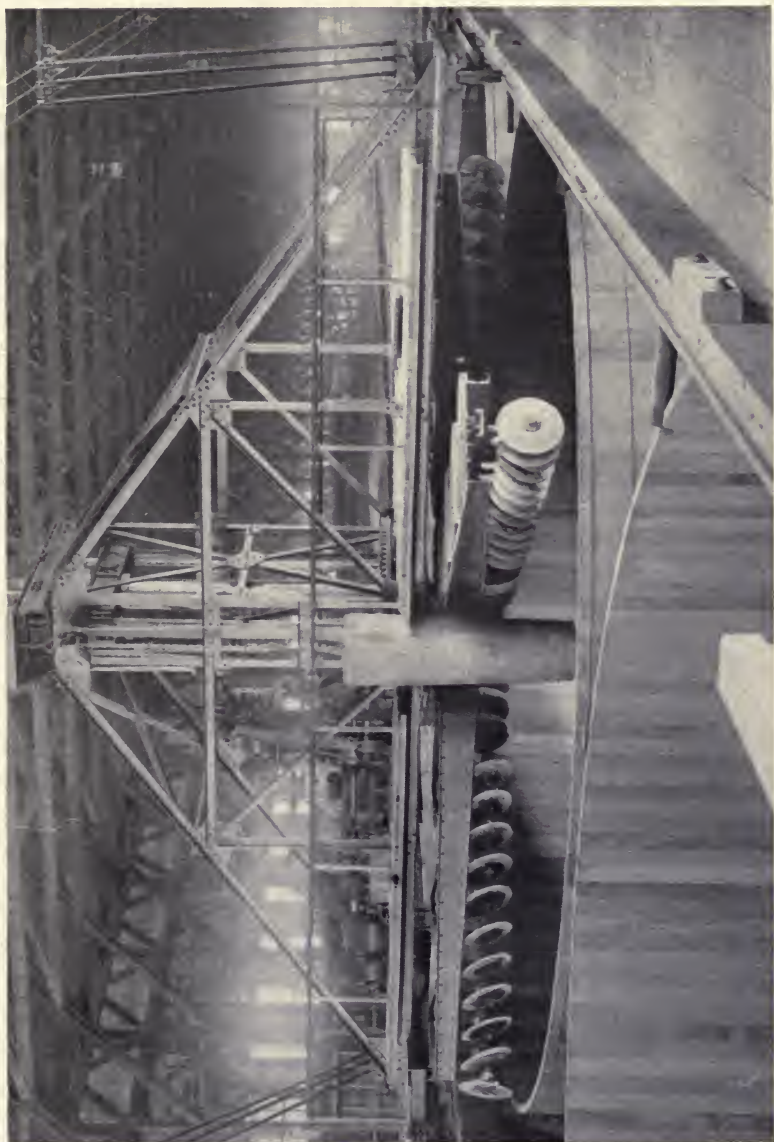

FIG. 2. BLAISDELL EXCAVATOR IN THE DESERT MILL

below the surface of the sand before the succeeding one is applied. Sand undergoes treatment for 12 to 15 days. Moisture in sand dis-

charged averages 15%. Sand residues at present average 0.03 oz. gold and 3.10 oz. silver per ton.

The treated sand is discharged by the excavator upon the sand-conveying system, so arranged as to run in the direction opposite to that when transferring. The sand as it is discharged falls upon a cross-conveyor running up an incline of 25° . As the tailing-pile builds up to the stacker, an extension of 18 ft. is added at the end. Arrangements are being made for a cross-conveyor in connection with the stacker.

All leachings from the sand-vats, as well as the plant solutions, are sampled, assayed, and titrated for cyanide and alkalinity daily. Attenuated leaching solutions are sent direct to weak sumps. Centrifugal pumps, when not pumping to treatment-vats, are in service circulating solution in sumps through cones for the purpose of aerating.

All potassium cyanide used in the treatment of sand, is dissolved in a small vat from which a 2-in. pipe-line is connected to the suction of a 4-in. centrifugal pump used to pump solutions on sand. By means of a table and float arranged on the vat, the desired strength of solution can be obtained by opening the 2-in. line and allowing the requisite amount of standard solution to be drawn through the pump with the weak solution from the weak sumps.

The slime plant has eleven 3-in. redwood vats 36 ft. diam. by 20 ft. deep for collecting and agitating slime; one vat of the same dimensions used in connection with the Butters filters for stock pulp, two Butters filter-vats containing 96 filter-frames each, and two tanks 24 ft. diam. and 12 ft. deep used for weak solution and water for washing slime on filters.

All of the 11 vats mentioned above are provided with rim overflow launders for receiving the clear overflow when collecting slime. The overflow goes to any of the three sump-tanks, 40 ft. diam. by 8 ft. deep, from which it is returned to the battery storage-tank by means of an 8-in. centrifugal pump. Eight of the eleven vats are provided with mechanical arm-agitators driven by a 30-hp. motor with gearing and friction-clutches over each vat. Agitators make 5 rev. per min. There are two sets of four-arm agitators quartering. The lower set, to which drags are hung for keeping the heavier fine sand in suspension, is 2 ft., and the upper set 8 ft., from the bottom. Any of the eight vats can be used for agitation, although at present but four are in use at the same time, leaving four of the agitation-vats and the three regular collectors for service in receiving and collecting the slime in the slime-bearing solutions. A charge of slime is drawn from the bottom of the collecting-vats by means of an 8-in. centrifugal pump without interrupting the collecting.

Previous to receiving a charge of thick pulp from the collectors, about 150 tons of barren solution is pumped into the agitator. To this is added 1000 lb. slacked lime and 600 lb. dissolved cyanide; the whole is agitated for one hour by the mechanical agitators and pumps. The charge of thick pulp is then pumped in. When thoroughly mixed, it has an average specific gravity of 1.144, that is,

21 parts of slime to 79 of solution. The mass is agitated for 30 hours, the mechanical agitation being assisted by compressed air, admitted

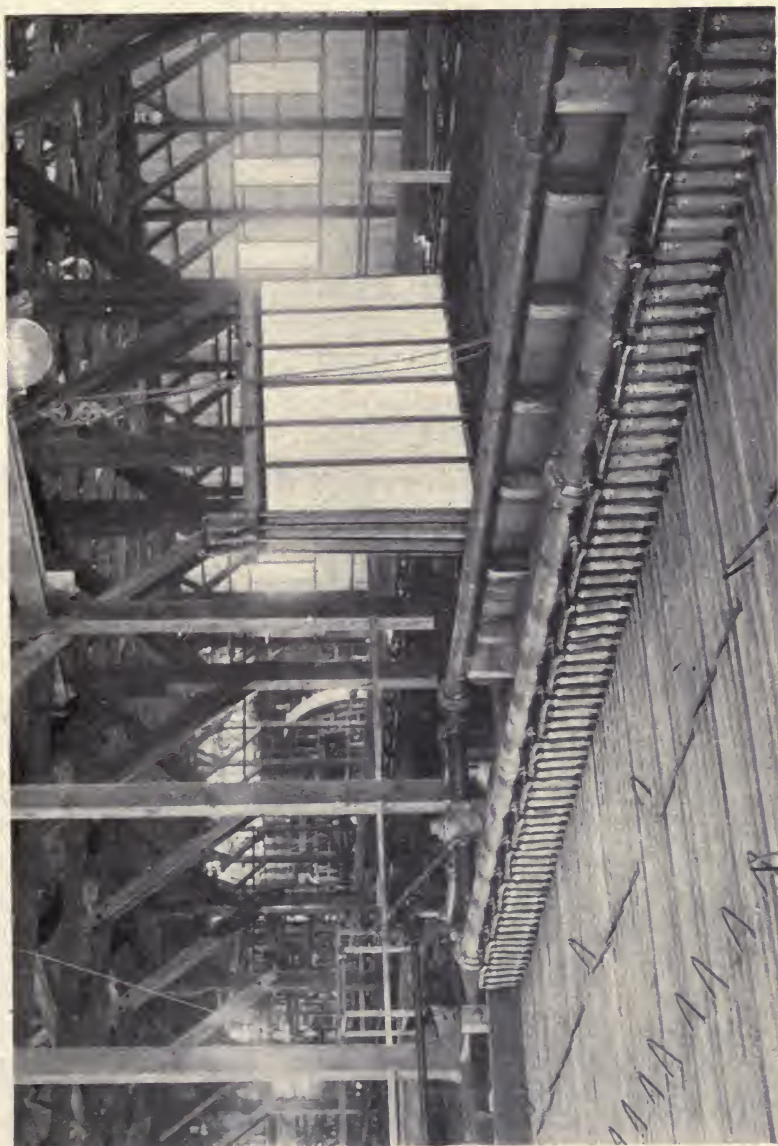

FIG. 3. THE BUTTERS FILTER IN THE DESERT MILL

through a perforated pipe running half across the bottom of the vat and by an 8-in. centrifugal pump, taking pulp from the bottom and discharging at the top of the vat. This is used when not in

service for other pumping. At the end of 30 hours, the agitation is stopped and the pulp allowed to settle for six hours, when about five feet of clear solution is decanted and run to the storage-vats for precipitation. The settled slime is then pumped to a second agitation-vat into which solution equivalent to that decanted has been pumped; agitation is continued for 24 hours, when the contents are delivered to the Butters filter stock-vat.

The following table gives the average time of each operation in the Butters filter, from filling the vat to discharging the cake:

	Minutes.
Filling with slime.....	22
Collecting cake, 23-in. vacuum.....	45
Pumping back slime.....	20
Filling with barren solution for wash.....	20
Washing cake, 23-in. vacuum.....	30
Discharging cake	3
Settling wash	5
Running back wash to vats.....	30
Pumping discharged slime	10
Total	185

Pumping in connection with the Butters filters is done by an 8-in. centrifugal pump, driven by a 20-hp. motor. Vacuum for the filters is supplied by a 10 by 10-in. duplex vacuum-pump, driven by a 15-hp. motor. All valves in connection with filtering operations are operated from a platform by a system of rods and levers. The first solution coming through the vacuum-pump, upon beginning a new cycle of operations, is turbid and goes to the circulation sumps. When the solution becomes clear, usually in five minutes, it is turned to the storage-vats for precipitation.

The thick slime-cake, having been discharged, is broken up for pumping by means of 1-in. jets of water under a 70-ft. head directed downward into the hopper of the filter-vats. A duplicate pumping system is being installed to make it possible to either diminish the time of a cycle of operations or allow more time for washing. A large launder for running back wash-solution will also change the time when completed.

A mixture of air and water was tried for discharging cake, but it was found that without careful attention and manipulation too much pressure would be used by the operator, thereby breaking the stitching in the filter-leaves. Accordingly, the cake is now discharged in the wash solution by admitting water under a 12-ft. head. The wash-solution is allowed to settle for about five minutes before running back, and then is drawn off to within about six inches of the thick slime in the hopper. By this means and the small amount of water from the jets, the slime can be easily pumped out with a moisture content of 60%. At the present time, an average of 125 tons of dry slime is being filtered and discharged per 24 hours.

All solutions for precipitation are collected in two tanks, 24 ft. diam., 8 ft. deep. From these the solution is pumped through a 4-in. Worthington meter to the zinc-boxes by means of two 3-in. Byron

Jackson centrifugal pumps, directly connected to 2-hp. motors. The precipitation room has a concrete floor sloping to a sump for drainage and collection of any drips or leaks.

There are fourteen zinc-boxes made of 3-in. redwood. Each box has seven compartments, each holding 15 cu. ft. zinc shaving above the screen-trays, making the total capacity of the box 105 cu. ft., or about 1600 lb. zinc shaving. The compartments of the boxes are arranged for an upward flow of solution.

The average amount of solution precipitated in 24 hours is 1200 tons; the tailing from the zinc-boxes assays from a trace to 11 cents per ton, increasing in value from the time immediately after one clean-up to the time of the next. Four clean-ups are made each month; five men working over-time with two men from the melting-room make the clean-up of fourteen boxes in two days. During the first one the shaving in the two-head compartments of the zinc-boxes is washed and the remainder moved up. The washing is done over the head compartment, and all precipitate is screened through a 30-mesh wire screen. The precipitate is allowed to settle and the solution is pumped by a 5 by 6-in. Knowles triplex pump through two Johnson filter-presses provided with 24 by 24-in. frames and leaves covered with 10-oz. duck. The settled precipitate in the zinc-box is bailed into tubs and dried in pans, without acid treatment, in a three-muffle drying furnace fired by coal. This precipitate, as well as that collected in the filter-presses, is thoroughly roasted, then pulverized and fluxed with 20 lb. borax, and 16 lb. bicarbonate of soda per 100 lb. precipitate. Formerly it was the custom to treat all the zinc-box product with sulphuric acid before filter-pressing; this practice required extra labor, expense, and time, and has been discontinued, as there was no appreciable increase in the fineness of the bullion produced.

The melting is done in six Faber du Faur tilting furnaces, equipped with graphite retorts, with a capacity of 80 lb. fluxed precipitate. Coke is used as fuel and the first pour is made six hours after starting fires. At the present time, 2800 lb. dried precipitate is melted into bullion in 24 hr. from the time of firing the furnaces. After a charge has melted down, sufficient precipitate is added to make a bullion bar weighing about 1200 oz. Troy. From 70,756 lb. roasted precipitate, 47,442 lb. bullion were produced; that is, without acid treatment, 67.05% of the precipitate went into bullion. This bullion had an average fineness of gold 13.5, silver 965, total 978.5 per thousand.

Pours are made directly into bullion-molds placed upon slag-pots. The molds have a slotted overflow for slag. This procedure does away with re-melting buttons into bars, made necessary when pours are made into slag-pots. The graphite retort in the furnaces will last for about 18 fusions, when they are discarded and new ones inserted.

Owing to the fact that the crushing takes place in cyanide solution and that the sand and slime are in contact with the solution from the time they enter the batteries, it is impossible to secure

trustworthy samples of sand and slime separately and keep a record of extraction by cyanide on each product. Accordingly, the difference between the gross content of the ore and the gold and silver in the concentrate shipped, is taken as the gold and silver content going to the cyanide plant. The extraction by cyanide is estimated from this by comparing with the total ounces of gold and silver shipped as bullion and refinery by-products, with the total contents in sand and slime residues as a check. The extraction by cyanidation from March 1 to August 1, 1907, figured in this manner, is 86.06% of the gold and 80.14% of the silver content. Combining this with the extraction by concentration, as above, 15.63% of the gold and 30.32% of the silver, gives a total extraction by concentration and cyanidation of 88.24% of the gold and 86.20% of the silver in the ore.

The average consumption of chemicals per ton of ore, for the last five months, has been: Potassium cyanide, 3.24 lb.; lime, 7.20 lb.; lead acetate, 0.38 lb., zinc shaving, 1.10 lb.; zinc shaving consumed per ton of solution precipitated, 0.32 pounds.

Changes and improvements in the plant now under way, such as increasing the concentration equipment by better classification, increasing the Butters filter capacity, and improving the present slime agitation equipment, will increase the percentage of extraction and decrease the cost of operations.

ECONOMY OF POWER IN CRUSHING ORE

By ERNEST A. HERSAM

(November 16, 1907)

This article is intended to direct a more general attention to some of the principles that underlie economy in ore-crushing and pulverization. It is not so much intended to present anything radically new; the purpose is rather to indicate, in a plain sort of way, the direction that progress is taking, and to throw emphasis upon some of the principles that seem to lead most directly to the greater economy of the future. As industry grows, so the pulverization of rock becomes more important. The extent of such work must be dictated by the markets, but in producing the result if is well to be sure that we have advanced the standard as far as it will go to the frontier of the unknown. We cannot judge our present practice entirely by the profit won.

It is important to distinguish between that part of the work that is necessary, and that part in which power is lost as friction and in other ways.

The energy consumed in crushing, though apparently an unavoidable constant, is variable. This is not due entirely to a difference in hardness of the rock. Hardness, it is true, represents the resistant quality against which the forces must be directed, but

there are other qualities of the ore and conditions of doing the work that so influence the results as to make hardness a subordinate feature. Lamination, crystallization, and many other physical characteristics may have so pronounced an influence as to render misleading a comparison based on hardness alone. Identical minerals show variable properties as they occur under different conditions; and a given ore of a certain place may be entirely unlike an ore of the same name known elsewhere. When a soft mineral occurs closely associated with a hard one, the soft mineral, even though present in but small amount, offers a line of less resistance to crushing, and the fracture, passing through the soft mineral, leaves uncrushed the hard constituents until the size is made so small as to require also the reduction of the hard particles. Thus coarse crushing may be done easily, sometimes, whereas positive and uniform fine crushing may require much more than a proportionate expenditure of energy.

The size of the fragments before they are crushed, compared with the size of the particles produced by the process, is, of course, in crushing, the measure of the useful work accomplished. The type of machine used, however, and the way of using it, has much to do with the power actually consumed. The energy required is in no case easy to predict definitely, nor is it at once learned by ordinary means of measurement. Some of the power is wasted. Only a part can be positively accounted for; and the part that has produced some telling effect can be learned only by paying attention to the variety of sizes in the particles of the product, and going into matters of measurement in a way that practical needs and immediate purposes rarely permit.

The total power required to crush and pulverize ore increases rapidly as the size is made smaller. Sizes often are expressed in maximum diametrical measurement, as determined by sifting; and to crush a ton of quarter-inch ore, for example, to an eighth-inch size requires much more power than to crush the same ore, if of half-inch size, to a quarter-inch size—the diameter, however, in either case, being reduced one-half. Power thus becomes a heavy item of cost when a process requires an extreme pulverization of the ore, and this becomes prohibitory with a low-grade ore where power is costly. A small amount of fine dust is found present in any crushed product. This is more serious than is realized. Not only is the fine ore found unsatisfactory for some subsequent process, but in producing it power has been wasted.

Some of the energy is lost in doing useless work, in crushing and pulverizing, despite every precaution. Friction between the particles of ore, and in the bearings of the machine, and a general loss of power in transmission all along, claim a share of the power. The ore deforms under stress, and this consumes power. Though the simple work of breaking the fragments apart is the only purpose sought, this work of deformation cannot be avoided and must be done before the rupture of the fragments begins.

The force resistant to crushing is simply the cohesion of the

mineral; but to overcome this force effectually, sufficient energy must be expended to do, not only this one thing, but additional work as well. The forces are badly directed for a purpose so definite. Instead of pulling the fragments asunder, our machinery squeezes them the harder to break them; and we are obliged to trust the forces, somehow, to find their way around to break whatever rock they can. Machinery is not capable of handling the pieces separately. No frictionless device can cut each piece in two and give to each the measured touch to fracture it. Shearing becomes confused with compression; compression in part becomes tension; and crushing becomes an indefinite action in which only certain resultant forces prevail.

In the jaws of an ordinary type of rock-breaker, the small fragments of ore that result from the first of the thrust, becoming packed and compressed, are not at once disengaged. These are not in condition to receive further pressure until released and rearranged. The ore so enclosed—pulverized, but retained—under the increasing pressure of the approaching surfaces, instead of being crushed, is partly rubbed and displaced along lines of less resistance. Many pieces of the ore, moderately fine, are in contact; and rubbing upon one another, they become merely abraded; and in doing so they consume energy by producing dust and heat from the friction.

In order to see more clearly the manner in which the power becomes distributed and finally consumed, it is best to consider separately the different directions in which it may go. All the real losses sooner or later appear in the calorific form of heat, unwanted and perhaps unrecognized. The power utilized, on the other hand, expended in overcoming the cohesion of the ore in breaking particles apart, is used in another way. This part is measurable as work done, not as heat lost, or some wasted form of energy, and this part of the power can be accounted for in the reduced size of the ore particles.

First among the general losses is the power lost as pure friction. Friction can be either in the machine, in the ore, or even, when regarded in a certain way, within the body of the single pieces of the ore itself, as a kind of plastic deformation. All these true frictional losses are encountered throughout. They extend from the shafting and belting, which convey power from the prime mover, to the ore itself at the moment of breaking. Thus, friction must be considered as unavoidable as any part of the work done, but it is a part that produces no desired effect, and first indicates a lack of economy, due to improper construction or imperfect conditions.

The second cause of loss arises from power given out in vibration in the foundation and elsewhere around the machinery, in supports and hangers, and disappearing in many ways. This energy is scattered in every direction. Foundations themselves, in some cases, consume much power; and the constant vibration everywhere, from the ground up to the dust-covered cobwebs on distant rafters, all are taking power to maintain the motion. Vibrations

of other kinds than this, through the air as well as through the foundation and supports, take away a small part of the energy constantly. Were other more trifling losses to receive separate attention, there could be included sound waves, heat waves, air pulsations, and even light, electricity, and other forms of energy, resulting from an unstable position of the pieces of ore in the machine, or caused elsewhere, as by the jarring of supports and foundations. Such wasted forms of energy being in part the result of friction, and in part of impact, are found everywhere, where there is motion, from the shafting, bearings, and belting, to the mass of ore itself. For the most part, however, the losses occur within the ore that is undergoing crushing.

Third among the general losses, is that due to the unavoidable deformation of the ore. This is not precisely a part of the general friction. It is work done in the interior of the unbroken fragments, and is over and above that work which should be necessary to overcome mere cohesion of the molecules in producing an actual rupture of the particles. It is the way in which much power generally goes; and although in many cases it is a loss that can be much reduced by taking advantage of the natural conditions, there is no hope of avoiding it entirely.

Fourth among the general losses could be named that which results from producing dust or fine below the size sought. The extent to which this becomes serious depends upon the subsequent process of treatment. To a certain degree, the production of dust signifies actual work done, however fine the dust may be. It is often to be regarded as work done improperly, however, if not an entire waste of the power expended upon it.

The friction of the machinery depends in general upon the construction of the machine and the condition in which it is kept. On the whole it is relatively a small part of the entire loss. Crushing machinery is not different from other kinds in principle; the same loss of power could occur in conveying motion for any purpose. The loss, however, would be increased two or three times by bad management or neglect, or correspondingly reduced by care and careful construction. Matters that should not escape attention, but that are neglected sometimes in regions remote from supplies and inspection, are: Protection of bearings from dust, the use of suitable lubricants and of proper belting, the alignment of shafting, the wear of gearing, and the care of bearing parts. Correct construction in the beginning often saves much cost in the end, but no construction can withstand ill use or neglect.

It is clear that power suffers loss in many ways. Although the purpose is to produce the single effect of crushing, by overcoming the cohesion of the solid ore, removing the fractured pieces from the field of intense attraction, the actual thing done is something quite different, and the resistance encountered is greater than should be necessary for doing that one thing alone. The energy so distributed can be considered as follows:

ENERGY EXPENDED IN CRUSHING.

IN THE MACHINERY.

In transmission to the machine:

- Friction in the bearings.
- Friction in the flexible belts, drives, etc.
- Circulation and friction of air at all moving parts.
- Forms of energy other than heat, of minor importance (electricity, etc.).

In the machine and foundation:

- Friction in the bearings.
- Air-friction and circulation.
- Tremor and vibration through foundations.
- Forms of energy other than heat, of minor importance (sound, etc.)

UPON THE ORE.

Between the fragments.

- Friction, resulting in heat.
- Numerous minor losses (sound, light, etc.).

Within the fragments.

- Plastic deformation.
- Unrecovered elastic deformation.
- Breaking.
- Excessive breaking, producing dust.

There have been cases where a change of lubricants has reduced the loss of power 30%, although conditions had been supposed correct before. The change of temperature between winter and summer has its influence, and though the power lost in this way is too variable to state definitely, it is important if lubricants are not suited to the climate and the season. Whenever a bearing is running hot, it represents power wasted. To run bearings even perceptibly warm, and particularly in cold places, is too costly to go unnoticed. When machinery is first started it does not run easily. This is influenced by the nature of the lubricants, the load, the condition of the belting, the dust, the duration of a previous period of idleness, and other factors. In the mill at the University of California, a good idea of the requirements of the different parts of the shafting and the varied work of different machines was obtained by taking periodic readings of a Thomson recording wattmeter, measuring the electric power used.

With good construction and management the power lost through friction in the machinery may be made less than 10% of that expended in other ways. It is a visible loss many times, and is one evident to the mechanic.

The loss of power among the ore-particles is much greater. The actual loss is mostly in some form of friction; and this is multiplied by an improper use of a machine. It will be found in any case to vary greatly with different rates of speed and with different methods of feeding and operating. It appears in two forms, namely, pure friction, and molecular friction or deformation.

When the disturbances that give rise to pure friction are examined, they are found to be more than surface deep. Surface friction is accompanied by strain and deformation beneath the surface. This consumes power in the molecular re-arrangement which, if permanent, often manifests itself as heat that appears to come

only from the surface action. The ore is constantly undergoing some kind of frictional loss, and some of this takes place in the interior of each piece before it actually breaks, while some is among pieces after rupture has occurred.

All such friction is lessened by a free discharge of the crushed ore as it becomes reduced to the size wanted. This condition is difficult to obtain. To crush ore, the masses must be retained between the approaching surfaces that administer the force; but while too great an amplitude in the motion of the pressure surfaces tends uselessly to compress the fragments, grinding these upon one another, and distributing the force in many directions, too little amplitude, on the other hand, fails to do more than deform some of the particles, and failing to break these, it wastes whatever energy is so expended. In a reciprocating jaw-crusher, at each revolution, whatever the amplitude, the jaws are certain to come to rest against the elastic strain of ore. The power must suffer loss each time the pressure is applied and released. Thus the loss in working would be most reduced by having exactly the right amplitude for the quantity of ore retained between the jaws at any one time, and by having sufficient voids between the pieces to provide a place for the crushed particles to occupy as soon as produced. This can be done by making the size of the original pieces uniform and comes from sizing before crushing.

Deformation is in part the cause of surface effects. It is the adaptation of the ore, under stress, without breaking, to new positions, forced by the pressure. It is a great consumer of power, varying with different kinds of ore, different rates of speed, and according to other conditions. In the amount of power consumed by deformation, the time element plays an important part. Give the ore time and it will bend or yield appreciably in any direction, tending to remain in the shape that suits the pressure upon it. Strike it a smart blow, allowing it no time to do this, and it will break always, when the blow is sufficiently forcible to correspond with the size of the fragment.

Ore cannot be worked under pressure like a plastic mass, of course, but there is a tendency for it to do this, and it is this quality that consumes the power. When no longer able to endure compression the ore breaks, but before it does so, it takes up energy in the slight alteration of shape, and the power consumed is the greater for the very difficulty with which it yields. With plenty of time many kinds of rock would bend under stress, and even to a greater extent than brief tests would show them capable of doing. It would be illustrated in a much exaggerated way by warmed glass, or a stick of plastic wax, which gradually would yield without breaking, changing its shape, or bending double if necessary, to occupy a position of least strain. Strain the substance suddenly, however, and it breaks.

There is, to be sure, a limit to the possible shortness of duration, or practical rapidity of motion, for any material to adapt its molecular condition to new needs; and along with the time must be con-

sidered other important and obvious factors (the temperature and the pressure applied) but the deformation is in a great measure a question of time, and the elastic limit and breaking strength are in many ways dependent. The study of explosives and of blasting, a knowledge of projectiles and of the results produced by their impact, and even a study of the rapid impact pulverizers, all bring into the consideration a time factor.

Experiments to show the definite effect of speed in crushing have not been numerous. The advantage of high speed, however, has been shown in many cases. Much has been learned already by experiment regarding the viscosity of solids, but this is not so well correlated with what is known of the energy required to crush them. The possible practicable variation in velocity is small. The work can not be instantaneous and neither must it be prolonged. The economy in certain impact pulverizers, and the advantages of high speed in numerous other machines would make it desirable to know more definitely about the power that is consumed by viscosity, and to learn the difference between this and the loss through elasticity, and to know exactly the part consumed by the fracture of the ore. All that can be said now is that much additional total power is required in running slowly upon certain kinds of tough rock; but, on the other hand, brittle or highly elastic rocks show little compensation for the mechanical loss there is in high speed.

The importance of a correct velocity can be learned even by working with a hand-hammer. Selecting a hammer that is a little too heavy for use upon rock that is tough, a man finds it difficult to obtain a satisfactory return for his labor. The same rock with the sharp quick blow of a lighter hammer, in the hands of a man properly skilled, shows a different result. The difference is not so much in the energy expended. It is in the speed of the blow. There must be a suitably high velocity to accord with the size of the fragment and the distance through which the rupture is made.

Tests of consumed power, measured by the effects, are difficult to make with precision. The measurement must be made upon irregular fragments of rock, and upon a crushed material in a form difficult to sort and measure. The product, like the original material, consists of particles of many different shapes and degrees of hardness. It is not easy even to learn what part of the power has been used in producing dust, distinguishing it from that lost as mere friction, because dust is difficult to collect, to size, and to measure. Each different size of particles represents the consumption of a definite proportion of the total power applied, but since each size must be calculated separately, it must be screened, collected, and considered by itself.

For some purposes all power that goes into the production of dust is lost. In other processes dust is of no injury, as long as all of it is recovered; and in some cases the production of dust may even be sought; but in any case, to learn of the hardness of the ore and the consumption of power upon it, the dust must be collected, and this must be sized, weighed, and calculated for the power it

has consumed. Sometimes in rough crushing this dust may comprise two or three per cent by weight of the crushed product, and the power it has consumed is shown to be large when calculated according to its size and the surface it represents.

Besides the plastic deformation there is still another important form of deformation sometimes called elastic deformation, in which the ore alters and then again regains its shape. Ore does not retain or consume power in this respect that it does not again give back when the pressure is released. The return of the power, however, may come at such a retarded time or be in such a direction as to produce less effect than if the elastic deformation had not occurred, and this dispersion of force, rather than the resistance to the original pressure, is seen to be the real cause of loss of power. There is always the possibility of utilizing an important part of the power that expends itself upon elasticity. The energy is stored and exists as an elastic strain. It is unlike that which overcame plasticity, for this consumed power and produced heat in making a permanent change of shape, while elasticity produced but little heat, reserving the energy to be given out again in a kinetic form.

Simple inspection of working machines shows how this elasticity of the ore yields energy in an ineffective way. Consider the jaw-crusher, for example, or one of the gyratory types. In these machines the motion is relatively slow. Under this action, an elastic fragment such as a piece of quartz, is compressed more and more by the jaws of the machine until finally, unable longer to withstand the stress, it breaks. As it does so, the balanced forces in the elastic strain of the particle are upset suddenly, and the whole fragment flies into many pieces by the release of the first rupture, and work is done by the energy that was reserved in the elasticity of the rock.

The loss of power through elasticity will be seen to be different in the different types of machines and under the different velocities of operating. Some crushers minimize this loss. Others recover power from elastic strain, but are wasteful of the plastic deformation by their slowness of motion. All rapidly acting machines, as a rule, are economical as far as plastic deformation is concerned. With elastic deformation this may or may not hold true, as will be seen. Also in a comparison of grinding machines with crushing machines, the difference between elasticity and plasticity of the ore must be carefully observed. True crushing devices are well suited to contend with elastic deformation, whereas they are not always best when the deformation is of the plastic kind. Thus impact pulverizers have their place, and rapid stamps, deriving their required impact from high velocity rather than through ponderous weight, are effective as crushers for certain kinds of ore. Higher speed in rolls and in all classes of crushers is desirable, up to the point where greater wear and heavier loss comes from the mechanical difficulties due to high speed. The tendency of improved construction has been to increase the speed. Better mechanism, improvements in bearings and means of lubrication, are making a speed possible now that once would have been considered impracticable.

In the stamp-battery it is seen how the work done upon elastic deformation is not well recovered. Whatever the depth of the ore upon the dies, or whatever the weight of the stamps, they are certain at each drop to come to rest against the elastic pressure of the ore. The rebound of the gravity stamps, with an interval of rest necessary for irregularities and contingencies is not recovered again. In rebounding the stamp does not acquire sufficient kinetic energy to be effective when dropping, nor does the rebound occur at a time favorable to aid in elevating the stamp, allowing the interval of rest necessary in a gravity stamp for the cam, with a slight variability in the power. Direct-acting steam-stamps make use of these forces by their rapid action, but in mills where battery amalgamation must be practised these rapidly reciprocating appliances cannot be used to advantage.

Jaw-crushers gain somewhat by the elasticity, as against the plasticity, of ore; rolls and gyratory crushers also recover much of this elastic force. Tube-mills, arrastres, and grinding machines, on the other hand, are not well devised to distinguish between the quality of elastic and of plastic deformation except in so far as the elastic deformation is accomplished by a quality of brittleness, or a narrow range within the elastic limit.

The Huntington and other centrifugal roller-mills are economical in this regard. By reason of their construction it is seen that the elastic reaction occurs at a time and in a direction to be effective in propagating a motion in a direction that aids the forward movement of the rollers, and in a manner to replace some of the power that would be necessary were plasticity, instead of elasticity, the restraining quality.

Friction within the ore is variable in different machines. All pulverizers in which the crushing surfaces, the jaws, liners, mullers, or moving parts slide over one another in place of approaching in a direction normal or perpendicular to their surfaces, fail to escape a heavy loss of power through friction and wear. It is necessary to distinguish between crushing action and grinding action by exactly this difference. A grinder is a machine which compresses the ore between surfaces moving tangentially or sliding over one another. A crusher compresses the ore between surfaces approaching normally or nearly so. Both effects, crushing and grinding, occur side by side to some extent, in all reducing machines, for it is not possible to direct a force into a mass of ore to produce motion without scattering the energy into a great variety of tangential displacements. In certain types of machines, however, the crushing feature is brought out as much as possible, and in others grinding predominates. In grinding machines the rupture of particles does not penetrate so much into the centres of the ore-pieces. In place of this, the tangential direction of motion, rubbing along the surface, or causing rotation of the particle, tends only to abrade the exterior, and in so doing tends to produce dust and waste power as friction.

Extremely fine pulverization requires these tangential devices in practical machines. With fine sizes the tangential motion is not

so serious. Unevenness in the texture of a wearing surface furnishes innumerable places of lodgment opposed to the direction of motion. Such places are large in size compared with the size of the small particles, and their great number results in countless applications (in a small way) of local normal forces, which hold and break the small particles so as to simulate crushing. It may be said in favor of grinding action for fine sizes, that any attempt to pulverize ore finely in true crushing machines requires thicker layers of the pulverized masses to produce a satisfactory output at a reasonable speed, while within such masses a grinding effect is produced which the very principle seeks to avoid. True crushing practised upon fine sizes brings out more seriously the elasticity of the liners, since these crushing surfaces are exposed to a pressure that is intermittently applied. In principle, however, the effect of crushing and not of grinding is to be sought, and always this is desirable for the coarse sizes.

Tube-mills and ball-pulverizers, by their action, become for the most part types of grinding machines. When the construction or operation provides for a drop-action of the balls, pebbles, or unattached parts, so that in rotating, these fall upon one another, or upon the lining, then the crushing effect begins to appear. However, the elasticity of the pebbles, or the balls, or the elasticity of any substance used in the liners, limits the economy of the crushing principle applied to extremely fine sizes. When the size of the particles of ore is thus very small, then the force to overcome the elasticity of the pebbles or balls becomes relatively great and this elasticity consumes much power compared with the crushing work actually done upon the ore. The hardest and most resistant material that can be obtained, for this reason, is desirable in the construction of machines where ore must be reduced to fine sizes, and especially is this true where slight crushing action accompanies mere grinding.

The final, useful, and necessary part of the work of crushing is that of totally outstripping the force of cohesion of the molecules along the needed lines of fracture; overcoming by distance the attraction that exists in the uncrushed ore. This is the real work to be done. It is against the single quality of hardness that the energy is necessarily directed. The mineralogist's scale of hardness should show this relative factor; it is this quality that would exist if elasticity and viscosity could be disregarded.

While the energy that appears to be exhausted upon the hardness of the rock is varied, in practice, by deformation, which is nearly inseparable from hardness in its effects, there is a final and unavoidable residual cohesion, to overcome which causes rupture, and which is not subject to deformation within the short time-limits of breaking. The energy expended on hardness does not so much depend upon the principle of the machine nor the manner in which the work is done. It is dependent upon the fineness of crushing which represents the effect produced. It can be judged by comparing the size of the particles after crushing with the size before. The energy actually expended in producing this effect can be measured

only by taking into account the friction and the deformation that accompanied the breaking under definite conditions.

The real work accomplished in crushing is thus measured by the extent of new surface made. It is desirable, many times, to measure this surface, and to learn by so doing how efficient any process of crushing has been. To measure the exact extent of such surface is not a simple operation. Nothing can be done more than to approximate it in various ways. Rittinger, Von Reytt, and others have found values in certain cases, but these, while difficult to obtain, have in the end been approximations depending upon certain estimates.

To judge the extent of the surface in a practical way, size the crushed product, and estimate the surface as a whole from the sizes of the screens and the average diameters of the particles. A certain relation exists between the average diameter of the particles, in a closely sized product, and the surface-area represented by such diameters. This relation can be taken as a constant under given conditions. The work in producing the surface represented by these diameters may not always be identical for different rocks. It will vary according to the kind of machine used, but the work of producing new surface under like conditions in uniform material is necessarily proportionate to this surface and to average diameters.

The unit of work is some certain area of the new surface made, or, more properly, it bears a direct relation to the area of fracture, one square inch of which signifies the production of two square inches of surface which did not exist before the fracture. Such a unit of work, or unit of fracture, can be regarded, if necessary, as though it were united into a certain single large fracture through solid rock, or again, as though a definite volume of ore were reduced from one definite size to another definite size. Practically, rock cannot be cut evenly by fracture. In practice, too, there are found crystals comprising a large part if not all of the rock substance; and there are many irregular qualities, cleavage and seams, that bring out various planes of weakness not encountered until some definite degree of fineness is reached. These planes lead to different shapes of particles, and, in a great measure, are the cause of the different degrees of hardness shown at different sizes. Their effect, moreover, is shown upon the average hardness of the rock.

In dealing thus with irregular shapes and sizes, it is necessary to classify the particles, whatever their shape, by the screens that separate them. In so doing, the theoretical cube would be taken as the basis of the surface measurement. Particles that actually pass rectangular openings differ from the theoretical cube in one way or another. Natural crystals are generally so misshapen and fractured as to give no clue to averages by which surfaces might be estimated. Where, however, a prevailing shape of the particles is so well known and so constant as to make it safe to allow for this quality, a constant factor may be used. Thus the factor k , as will later appear, may be taken to represent the ratio between the surface of a mass of ore, when consisting of particles that would pass a given rectangular screen-opening, and of the same mass existing in such theoretical

cubes as should exactly be capable of passing the same screen. Such a relation gives k a value between 1.2 and 1.7.

If a piece of rock, one cubic inch in size, be broken in two with a clean cut parallel with one of the faces, there are made two square inches of new rock surface, and there has been made a cut through the fragment of one square inch in area. This square inch of fracture through uniform substance may be taken as a unit of work, or more properly, a unit of result accomplished. To crush a cubic inch of ore into half-inch cubes would signify producing a fracture in three directions each of one square inch in area, through the one-inch cube. Such a reduction of size represents three square inches of new fracture made, and if a be understood to be the work of producing one square inch of fracture, then breaking a cube into half-inch cubes represents the work of $3a$. If k be taken as a factor expressing the relation between the surface of solids of known average shape to cubes of the corresponding screen diameter, then $3ka$ is the work of breaking each cubic inch of irregular ore from a size that would pass a one-inch screen to a size that would pass a screen half that diameter. Thus ka , wherever k is constant and known, can be used in place of a , throughout the work.

Without careful sizing it would be difficult to learn how efficiently the work is done. It is too crude an approximation for any but the roughest purposes to learn only the power to crush a given weight of ore down to a certain size. The initial size is important; moreover, an important part of the crushed product could pass a screen much finer than the one stated. When seeking to obtain a product composed, for example, of one-inch pieces, often half or more of the product will pass a three-quarter-inch screen, a third, or more, will often pass a half-inch screen, and much might be even finer than this. Careful examination often shows two or three per cent of extremely fine dust, representing much more power than its amount would first suggest. However difficult it may be to collect and measure the dust produced, it should not be overlooked in estimating the actual work done.

Different kinds of rock act differently in this way. Different crushers produce different results in the uniformity of product and dust that is made. Tough rock, deforming under pressure, will tend toward a large proportion of the maximum sized particles. Brittle ore causes more than a corresponding quantity of fine. The work done, in every case, consists in producing this new surface, however fine the size of the crushed particles. Thus in measuring the hardness of a rock, or the efficiency of a machine, the undersizes cannot be neglected.

Since $3a$, in which a is expressed in foot-pounds, represents the work of crushing a one-inch piece of ore to half-inch pieces, it is necessary to extend the expression to represent the work of crushing a larger body of ore consisting of particles of any definite size. This merely is a relation between diameter, surface, and mass; and the expression may be extended in the following way: A cube of ore, one inch in size, broken into any number of smaller but uniform

cubes, necessarily will be cut by planes. There are three directions in which these planes will extend, in order to make cubes, making angles of 90° between planes; and in each one of these three directions there will be, not always one plane, but a system of parallel planes, the distance apart and the number of which depends upon the fineness of crushing. The number of parallel planes in any one of the three directions will be $n-1$ if n be taken as the number of pieces produced out of the linear dimension of the original piece. Thus cutting one-inch cubes into eighth-inch cubes makes $n=8$.

The total number of planes made by fracturing the one-inch cube into small cubes thus is $3(n-1)$ and each of these is one square inch in area. So when a represents the work of cutting through one square inch of rock, the work of fracturing a one-inch cube into smaller cubes is: $3a(n-1)$.

Applied to any cube, of any size, the value n , becomes $\frac{D}{d}$ where D and d , respectively, are the diameters before and after the crushing. The fracture-planes now are of different area, since the single piece of ore is no longer of unit size. The area of the newly considered fracture-planes naturally will be D^2 , since D is the diameter of the piece in linear units. Thus making one cut through this different-size piece represents aD^2 , of work, instead of a , as in the unit piece, where D had a value of 1. The formula applying to a cube of any size (a being the work represented by a square inch of fracture) thus is seen to be:

$$3aD^2\left(\frac{D}{d}-1\right).$$

The number of such original pieces (whether more than one or less) that could be made from the mass of a cubic inch of solid rock, or in other words, the number of cubical pieces per cubic inch is, $\frac{1}{D^3}$. Here, 1 is the unit of volume, and D^3 is the volume of any of the single particles produced from it. Thus the work per cubic inch becomes:

$$\frac{1}{D^3} \cdot 3aD^2 \cdot \left(\frac{D}{d}-1\right); \text{ or } 3a \left(\frac{1}{d}-\frac{1}{D}\right).$$

In such a problem, for example, as where a 20-hp. engine is crushing a certain output of ore, reducing it from a 2-in. size to a $\frac{1}{8}$ -in. size, and where it is required to estimate from this what power would be necessary to crush the same 2-in. to $\frac{1}{32}$ -in. size, instead of to the $\frac{1}{8}$ -in. size, the value $3a$ may be taken as a constant where the ore is uniform and the crushing appliance so adapted to its requirements as to be equally efficient. The problem then expressed by proportion is as follows:

$$20 : x :: 3a \left(\frac{1}{8}-\frac{1}{2}\right) : 3a \left(\frac{1}{32}-\frac{1}{2}\right).$$

In this case $x=84$.

When it is desired to show the power necessary to crush a given weight of ore, as a ton, or a certain number of tons, it then becomes

necessary to take account of the specific gravity, S , of the ore, or the number of cubic inches of solid rock contained in a ton of ore, allowing a to stand for the work, in foot pounds, of producing a square inch of fracture. As there are 55,320 cubic inches in a ton of a substance (water) having a specific gravity of 1, there will be $\frac{55,320}{S}$ cu. in. of solid rock represented in a ton of ore. Thus the work of crushing a ton of ore, shown in work units, giving comparative values for a , would be:

$$\frac{55,320}{S} \cdot 3a \left(\frac{1}{d} - \frac{1}{D} \right) \text{ ft. lb. per ton.}$$

OR:

$$\frac{\frac{55,320}{S} 3a \left(\frac{1}{d} - \frac{1}{D} \right)}{33,000 \times 60} \text{ hp. hr. per ton.}$$

Or simplifying:

$$a \left(\frac{0.08382}{S} \left(\frac{1}{d} - \frac{1}{D} \right) \right) \text{ hp. hr. per ton.}$$

The values of a that will be learned by a careful sizing test will be significant constants, showing the characteristics of the rock. The motion and principle of the machine influence the value of a . The size of the ore pieces giving greater or less opportunity for deformation shows variable effects. The crystalline character of certain rocks brings out different qualities which affect the value of a at different sizes. The speed of running has much effect and should be in accord with the size and quality of the ore. The value found for a , in any given case, makes a standard of comparison, for crushing the same ore to any other size, or in any other machine, and gives a figure that should be equalled or improved in further work upon the same ore, or the reason learned why this cannot be done.

Thus while a stands for a definite amount of work (1 sq. in. of fracture, in foot-pounds) with a given ore, it can not be taken as a constant without regard for the speed, the conditions of temperature and moisture, and many circumstances that influence the hardness or modify the efficiency. The friction and other losses properly should not be included in the stated value of a . In practically representing it as a result of any test, the friction cannot be entirely eliminated nor the result accurately corrected to allow for it. Running a machine with no load is not an exact measure of the losses sustained in running the same machine while doing its work, and there are numerous other conditions, aside from friction, that have no proper units to express their values. The friction in the ore is dependent upon the mass of material. This is modified by the direction of forces, the amplitude of motion, and the brittleness or the toughness of the rock upsetting the relation that existed at the start. The lowest value for a , however, under the most favorable conditions that can be found, should be an approach to the absolute requirements of the crushing work.

Tests have been made in which ores of various kinds were used, in which the ore was crushed under a dropping stamp, of a known weight, falling through a measured distance, upon a definite quantity of a given ore, prepared and selected of a uniform size and placed in a specially made mortar to receive the single blow of the stamp, and then sized, weighed, and calculated; these tests, or some of them, show a gratifying constancy and give values of a which, for those ores, would seem an ideal to be sought in practice.

It is of interest to observe what values a may have for general ores. These vary so widely between soft rock and hard, and between different varieties of the same mineral, as it occurs in different lodes, that no one mineral can be taken as a standard of comparison. Each ore shows its own minimum value when the conditions for crushing it are made to accord with its needs. Values of a between 2 and 5 are not uncommon. To take some of the common practical estimates, if power is required at the rate of 1 hp. hr. per ton of ore, to crush from 6-in. size to the size of $2\frac{1}{2}$ in., assuming a specific gravity of 3, and regarding k as 1, a value of a is found to be 153. If 30% of the ore exactly passes a 1-in. opening, the remainder passing the $2\frac{1}{2}$ -in. opening as before, a has a value of 120; and if 10% of the whole passes a $\frac{1}{8}$ -in. opening, while 20% is of the 1-in. size, a has a value of 116. Similarly, if it require $6\frac{1}{4}$ hp. to crush a ton per hour of $2\frac{1}{2}$ -in. ore to $\frac{1}{16}$ -in. size, producing no undersizes, a takes a value of 14.31. The undersizes depend upon the brittleness of the ore and the way in which the work is done. They are variable in amount in different ores, and they should not be approximated by estimates. The work done is often two or more times as great as would be indicated if the largest size were taken as a criterion of the size of the product, and the value of a correspondingly is much smaller than would be indicated if it were so considered. Thus in this latter case such a value as 7 for a might be expected when calculated upon sizes.

The attainment of fullest economy in crushing will be found in a speed that is sufficiently high for tough ore, an amplitude that is adequate for elastic ore, and from a moderation of both speed and amplitude for brittle ore. Whenever the reduction in size is intended to be great, the fine must be protected from further crushing either by water suspension, repeated sizing, or abundant opportunity for rearrangement of the compressed ore by the provision of interstitial space that accompanies uniform sizing. It depends upon producing the effect of crushing rather than of grinding, particularly upon coarse sizes; and of employing hard and non-elastic surfaces in contact with the ore. It demands solid foundations for machinery, care, cleanliness, and protection of bearings, tested lubricants, and the avoidance of all unnecessary irregularity of shape in high-speed running parts designed for the construction.

THE MECHANICS OF ORE-CRUSHING

(February 1, 1908)

The Editor:

Sir—Ernest A. Hersam, in his paper on 'Economy of Power in Crushing Ore,' in your issue of November 16, has passed in review a large number of the conditions present in ore-breaking and comminution, and his paper in consequence is full of valuable suggestions. It may be taken as a starting point for a more exhaustive examination of the subject. This, however, necessitates the accumulation of experimental data, and only by such investigation can true and useful conclusions be drawn, capable of convenient expression in the form of working formulae. In the absence of such data the mathematical deductions presented in the paper can only be considered as applying to a very special set of conditions, and it is to be hoped that Mr. Hersam, with the laboratory facilities at his command, will extend his researches, and lead the way to a clearer comprehension of the phenomena of crushing, and of the economical application of power to produce desired results.

Although we have to deal with mixtures of irregular masses of many sizes in the practical crushing of rocks and ores, it is obvious that the initial step toward an understanding of the mathematical effects produced under complicated conditions can best be reached by an examination of the phenomena of crushing single masses of symmetrical shape. The average shapes of rock-fragments are approximately either spheroids or ellipsoids. The behavior of ore particles settling in water confirms this. Such being the case, we may properly begin our study by subjecting spheres to strains similar to those induced in ore-particles in practical crushing.

It has been my privilege to conduct a few experiments of this character, which were unfortunately interrupted before sufficient data for safe generalizations had been obtained. The results, however, were so uniform under similar conditions, and so different from those anticipated from theoretical considerations, as to emphasize the need of a thorough experimental investigation of the subject. As an example, it was found in the crushing of glass spheres 1 in. diam. in rolls set $\frac{1}{3}$ in. apart, that with only a few exceptions in several hundred experiments the sphere ruptured into six principal pieces, five being relatively large fragments with irregular fracture-planes or surfaces, and one being an elongated fragment the length of which almost equaled the entire distance between the points of contact of the opposing roll-faces with the original sphere. The large fragments could be refitted in the great majority of cases so as to re-establish the sphere, which was then found to contain a hollow space having the form of an elongated ellipsoid terminating in small round openings at the points of contact with the roll-faces. The elongated fragment had come from this hollow space, which, however, it did not completely re-fill. A considerable quantity of small fragments and finely pulverized material had been produced in the interior of the sphere between the elongated fragment and

the larger pieces. The volume of this interior ellipsoidal cavity, as determined by displacement of water, averaged about 10% of the whole, and the volume of the elongated fragment was about 4.5% of the entire sphere, leaving about 5.5% of relatively fine comminution as the result of a single passage of the sphere through the rolls.

In effect the tendency of the sphere under compression had been to behave as a beam between the points of application of the force, and to shear off all that portion not acting as such beam. Moreover the shape of the elongated fragment was approximately

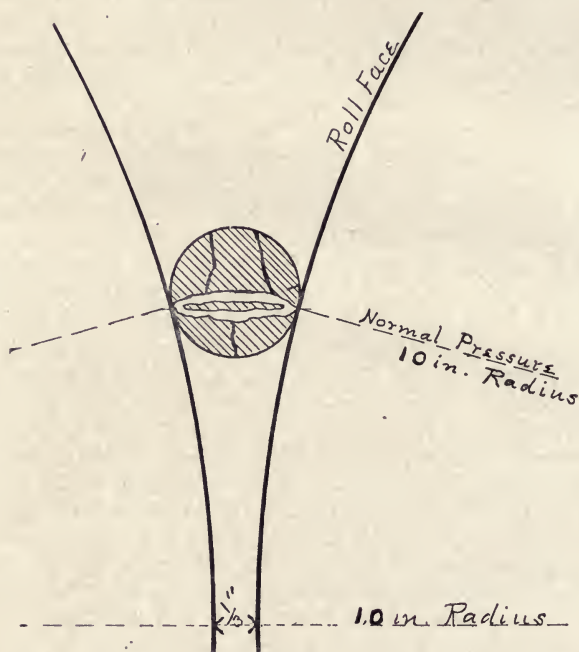

FIG. 4

that of the figure produced by the lines of distribution of strain within a beam, as experimentally determined when compression is applied to the two ends thereof through simple points of contact.

It was also noted that the larger fragments commonly showed incipient concentric fracture-surfaces indicating the transmission of spherical waves of compression, starting from the points of contact with the rolls, and widening out therefrom. Exactly similar results in all details were obtained by crushing such spheres in rolls and in jaw-crushers. Subsequently, selected Baltic pebbles were crushed under like conditions, yielding similar results, sometimes as perfect as in the case of the glass spheres, but original planes of weakness in the pebbles usually modified the forms of the fragments materially. Selected pebbles of granitoid rocks from glacial moraines gave results more nearly approximating those with the glass

balls, except that the elongated fragment was more irregular in outline.

Very different results were obtained in crushing by stamps. In these experiments steel bars, $\frac{3}{4}$ in. high, were placed in the die upon either side of the spheres, which were 1 in. diam. The stamp accordingly came to rest upon the steel bars; the crushing effect thus being due solely to impact of the falling stamp upon the sphere. The weight of the stamp was 850 lb., and height of drop to the steel bars, $7\frac{1}{4}$ in. In all cases the upper portion of the sphere was irregularly fractured, the lower portion was reduced to small particles, and in the centre, in contact with the die, was found a quantity of finely comminuted material. Manifestly the comminution had been due to rupture produced by strains set up by reflected waves of compression meeting oncoming compressive waves.

Further experiments on the crushing of granite, syenite, and many varieties of ores, with and without disseminated sulphides of iron, copper, and lead, brought out a few surprising facts. It was found that materials that had been kiln-dried until they contained less than 2% moisture, yielded sizing-curves which were practically coincident when similar crushing conditions had been maintained, irrespective of the mineral composition of the material. It was also found that, when reducing ores in the normal way in rolls, intermediate screening out of material finer than No. 28 mesh (0.6096 mm.) between successive crushings did not affect the sizing-curves of the total resultant product. It was further observed that the quantity of fine product rapidly increased with the quantity of water of imbibition in the ore up to about 7%. No measurement of power consumed was attempted, but sufficient has been stated to indicate how far we probably are from accurate knowledge of how mineral aggregates behave under the conditions of crushing, adequate for generalization and reduction to mathematical expressions. Systematic experimental investigation of these phenomena would undoubtedly lead to results of immense practical value.

COURTENAY DE KALB.

Los Angeles, December 21.

SLIMING ORE FOR CYANIDATION

By MARK R. LAMB

(November 23, 1908)

The numerous recent attempts to treat any and all ores as 'all slime' have resulted in much valuable information. It is not so certain from the present outlook that the sliming of all the ore is generally advisable or even possible. It will be remembered that E. M. Hamilton brought this out plainly in his report on El Oro ores. However, the recent great improvement in slime-filtration seems to be responsible for the prevailing opinion that it is possible, even easier, to treat and wash sand by agitation and

vacuum-filtration than by leaching. As is usually the case in metallurgy, there is a happy medium method and the recent partial failures seem to have pointed this out. It is necessary to premise such a note as this with the clear statement that no two ores are mechanically alike—that in all cases individual experiments must be made. With this understood, it is safe to say that sand cannot always be filtered successfully on vacuum-filters.

One plant was designed and erected along these lines after careful and repeated tests (not mechanical) and it now transpires that although extraction from the finely ground ore is rapid and all that can be desired, it is practically impossible to agitate with geared stirrers if the pulp is once allowed to settle. Further, it is practically impossible to keep the pulp in suspension during filtration. The ore is largely hematite and while a part grinds almost to a solution, being very difficult to filter, another part remains as a very heavy sand, settling like shot and packing like cement. This problem is to be solved by air-lift agitation and subsequent classification. The separated sand will be washed in a comparatively small leaching plant. This classification will be simple and allows of a leaching rate of about three inches per hour.

Set off against this part and its results, the recent experiments made on a large scale by a company in Mexico which expects to re-treat sand residue. The sand, already clean of slime, was re-ground to practically 200 mesh and has been found to leach nicely even at this fineness. Moreover, the pulp, containing little slime even after the re-grinding, stays in suspension in the filter-box without any special means of agitation and forms a 2-in. cake on a Butters filter-leaf in 20 minutes. At this rate the capacity of the filter is three times what it is under ordinary conditions and it may figure out cheaper to filter this 'all-sand' pulp; or it may be cheaper to give the final water-wash (after air-agitation with wash solutions) in sand-vats.

Another plant treats an exceedingly fine slime, which requires a low vacuum at the beginning of filtration to prevent drawing dirty solutions through the filters, and what is worse, drawing slime into the interior of the filter-leaves. This trouble was experienced at first, but the simple expedient of starting gently removed the source of trouble. This filter was too small for the work, being supplied with pulp containing a large proportion of sand. After this coarse sand was removed and it was not necessary to hurry filtration, the solution passed clear enough to be sent to the precipitation-boxes without previous clarification.

Another plant of stamps, with sand and slime-vats, expected to place two tube-mills for re-grinding and therefore obtained a filter large enough to wash the (supposed) increased tonnage of slime. This increase did not come with fine grinding, although the filter is now supplied with its full capacity of slime by an increase in the number of stamps. The slime, as it comes from the mill, will settle only to about 1.1 sp.gr. (7 to 1), showing its extremely fine state, yet the effluent solution from the filter is entirely clear—much better

than the decanted solutions, and even these latter are sent direct to the zinc-dust precipitation-vats. The classification is made with cones and considerable slime goes to the leaching-vats and the slime contains little or no sand. For this reason the slime forms a cake uniform in thickness from the top of the filter-leaf to the bottom, and, in spite of the fact that sand is absent, the slime washes evenly and quickly. This is a slime that will not decant much below 78% moisture in 15 hr., which in the design of the plant meant either an excessively large slime-plant of vats for settling or a large loss of dissolved precious metal.

It seems to be proved that no one can tell by looking at an ore or slime, or by testing it merely by concentration and cyanidation, how it will agitate and filter, and that tests to determine its probable mechanical behavior may entirely change proposed practice. Air-lift agitation has solved the problem of cheap and effective agitation of either sand or slime, but from the fact that fine grinding will increase extraction it does not follow that the entire mill product should be treated as slime. When it can be so treated such a plant is, of course, ideally small, self-contained, inexpensive, and easily operated.

CYANIDATION IN NEVADA

(November 30, 1907)

The Editor:

Sir—Although a great deal has been written regarding the mines of Goldfield and the surrounding districts, comparatively little has appeared in print regarding the treatment of the ores produced by these mines. The article by A. R. Parsons (in your issue of October 19) is a notable exception.

In looking over the list of mills operating in these districts, it is interesting to note that the predominating scheme of treatment is wet crushing and cyaniding; amalgamation, concentration, and re-grinding forming details of the general plan of treatment. The idea seems to prevail that this is the only process suitable for these ores. Engineers know how difficult it is to introduce a new process into a district where certain methods have come to be recognized as standard, even though the proposed process has been highly successful elsewhere. Having this in mind, and desiring to overcome these objections, I propose a discussion on the subject of the best method of treating the sulphide and sulpho-telluride ores of Goldfield. The ores of Tonopah differ from those of Goldfield in one important particular—the presence of silver—and it would probably be best not to consider these, at least for the present.

By 'best' method is meant that one which yields the greatest ultimate profit. The following is a provisional description of the Goldfield ore: The ore is a hard white quartz averaging about 85% silica, 7% pyrite, and about 8% lime, magnesia, and alumina, the latter being derived from the wall-rocks. The ore carries about 3

oz. gold and no silver. The gold is in a fine state of division and does not readily plate. The sulphides are very fine and uniformly disseminated through the rock. The assay-value of the sulphides runs from \$400 up. Tellurides of gold are frequently present.

For this ore I propose the following scheme of treatment: Preliminary crushing in breakers and roughing rolls and fine crushing to 25 or 30 mesh in ball-mills after drying. Oxidizing roasting in Edwards furnaces and final leaching with cyanide solution. The details might have to be changed so as to include re-grinding and amalgamation after roasting, in which case separate treatment must be provided for the sand and slime. I have not attempted to go into the details of the above plan as they can be best brought out later on.

I would suggest that the process now in operation be designated as the Nevada Wet Process and the proposed one as the Nevada Roasting Process. There is nothing so original in either as to warrant such distinctive names, but it is convenient for the purposes of discussion.

R. STUART BROWNE.

San Francisco, November 18.

(January 11, 1908)

The Editor:

Sir—In your issue of November 30, under the heading 'Cyanidation in Nevada,' R. Stuart Browne makes several statements in regard to the Goldfield ores, in which I think he is mistaken. In the first place Mr. Browne remarks that the ore is "a hard white quartz averaging about 85% silica, 7% pyrite, and about 8% lime, magnesia, etc." As a matter of fact, the ore is usually an altered and silicified dacite, with very little white quartz present. In the oxidized zone the silicification is especially strong, and the ore gradates from rock showing its original porphyritic structure to a dark brecciated quartz. In the sulphide zone the silicification is hardly so marked, but the ore is still essentially an altered dacite, in places changed to a dark flinty quartz, while in others the original structure of the rock is still plainly visible. Taking it as a whole, it forms a fairly hard tough rock, not easily reduced to a fine sand.

Mr. Browne also remarks that "tellurides of gold are frequently present." This is true only to a very limited extent. At the Mohawk, Great Bend, and several other mines, a little tellurium is present in the very high-grade ore, but in a great many cases the so-called telluride of gold is a form of tetrahedrite. Bismuthinite (bismuth sulphide) has also been mistaken for one of the telluride minerals in two or three cases. As a matter of fact, it is extremely doubtful whether any noticeable quantity of tellurium could be found in the ordinary low-grade ore of the camp of the grade mentioned by Mr. Browne (3 oz. gold). At the Combination mine during the three years that I was in charge of operations, a special look-out was kept for specimens of telluride minerals, but we were unable to find

a single specimen in which the presence of tellurium was conclusively proved. I am, therefore, of the opinion that as far as the treatment of the milling grade of ore is concerned, with the possible exception of one or two of the mines in the Diamondfield area, the presence of tellurides need not be considered.

With such an ore as I have described, in which the gold is so finely disseminated, it seems to me very doubtful whether a good extraction could be obtained without comparatively fine grinding in addition to roasting. I am not sufficiently familiar with good roasting practice to form any idea of the probable cost of roasting Goldfield ores, but with coal at from \$16 to \$20 per ton, and crude oil at \$2.70 per bbl. or thereabout, I am of the opinion that the cost of roasting the ore would exceed the additional cost of re-grinding to a finer state of division. During the seven months, from July 1, 1906, to February 1, 1907, the cost of re-grinding sand with a 4 by 16-ft. tube-mill of trunnion type, fitted with silex lining, was approximately 70 cents per ton of sand re-ground. This, I take it, is considerably less than the cost of roasting, with the best possible arrangement.

EDGAR A. COLLINS.

Tonopah, December 8.

(January 25, 1908)

The Editor:

Sir—The article by R. S. Browne in your issue of November 30 brings up a subject of extreme interest at this time when smelter rates have been raised so high and settlements deferred so long as practically to prohibit the shipment of ore, and it is to be hoped that those metallurgists who have studied the Goldfield ores will publish such data as they may have, that methods of treatment will be brought forward and compared, to the end that properly designed mills may be erected and independence from the smelters established.

In furtherance of this idea I am pleased to give some data on tests recently concluded on ores furnished me by the Goldfield Con. Mines Co. and to outline the method of treatment that appeals to me as most economical.

The ore was the characteristic sulphide ore of the Mohawk vein, being very silicious and carrying about 8% sulphides finely disseminated throughout the matrix. These sulphides, besides the iron pyrite, contained tellurium in appreciable quantity, arsenic, and traces of copper. [Since writing the above I see that E. A. Collins questions the presence of tellurium. I can state for his information that in these samples the tellurium was determined positively by chemical analysis. Also that on a notable shipment of Bonanza ore the analysis showed 2.42% tellurium and 2.00% gold indicating the mineral calaverite, and I have reason to believe that the greater part of the gold in the low-grade sulphide ore is present as a telluride.]

Former tests upon the oxidized ores had given 94% extraction by simple fine grinding and agitation (as shown in a former article in your issue of August 25, 1906), and with this idea in view a portion of the ore was ground to 150 mesh, properly neutralized and agitated with 0.25% KCN solution. The extraction, however, was so poor that further efforts in this direction were abandoned.

A series of tests was then made using what Mr. Browne has seen fit to term the Nevada wet method, that is, the ore was ground to 40 mesh, amalgamated and then concentrated, the tailing was re-ground to 150 mesh, again concentrated, and passed to agitators with 0.25% KCN solution.

The results of these tests varied considerably and depended upon most careful and perfect concentration. The best results obtained by this method showed a final extraction of 92% on ore assaying 2.5 oz. gold, worth \$51.67 per ton, distributed as follows:

	Per ton of ore		Per-centage.
	Oz.	Value.	
By Amalgamation	0.108	\$2.16	4.20
By first concentration on 40 mesh obtained 6.43% worth \$398.07 per ton of concentrate, equal to.		25.60	49.54
By second concentration on 150 mesh obtained 2.5% concentrate worth \$188.07 per ton of concentrate, equal to.....		4.70	9.09
By cyanidation		15.08	29.18
Cyanide consumption 2.6 lb. per ton. Residue assay, 4.13.			

The difficulty of getting regularly the perfect concentration so necessary to the success of this process, led to tests by roasting. A number of tests were made crushing to 10 mesh, roasting, and leaching. These showed extractions as high as 87.5% with a cyanide consumption of 1.6 lb. per ton. The ore in roasting lost 13% by weight.

The next tests were to re-grind to 30 mesh after roasting at 10 mesh and then amalgamating, concentrating any heavy oxides, and leaching the tailing with cyanide solution. Some of these tests gave good results, the best extractions being as follows:

Roasted heading assayed 2.82 oz. gold, worth \$58.29.

	10 mesh.		30 mesh.	
	Extracted.	%	Extracted.	%
By amalgamation	\$18.40	31.56	\$26.04	44.67
By concentration	3.24	5.56	9.35	16.04
By cyanidation	32.50	56.80	21.25	36.46
Total extraction		93.92		97.17
Residues assay \$4.13 on the 10 mesh, and \$1.65 on the 30 mesh.				

These were given four days' leaching.

Another test without amalgamation and concentration, but re-grinding the roasted 10 mesh to 30 mesh, gave equally good results by direct cyanidation, the extraction being 97.2 per cent.

While these tests as regards extraction were all that could be desired, considerable trouble in leaching was encountered. The slime formed in re-grinding caused extremely slow percolation and

a tendency to channel, and many of the tests showed great irregularity from this cause. It was evident that in practice it would be necessary to separate slime from sand and as this would complicate the plant, further tests were made by re-grinding the roasted 10-mesh ore to slime or to pass 80, 100, and 150-mesh screen, agitating in 0.25% KCN solution for 12 hours and obtaining the following extractions:

Ground to 80 mesh.....	95.8
Ground to 100 mesh.....	97.6
Ground to 150 mesh.....	96.4
KCN consumption being 2.0 lb. per ton of ore.	

These last results were so regular and so satisfactory that unless mechanical difficulties, high costs, or other objections were found, I should consider it by all odds the best method of treatment.

Let us then consider the mechanical arrangement necessary for such a method of treatment and see if there are any well founded objections too serious to overcome. Such a scheme of treatment involves:

1. Coarse crushing in breakers.
2. Drying the ore. (This may not be necessary when grinding to 10 mesh.)
3. Dry crushing to 10 mesh.
4. Roasting.
5. Re-grinding to 100 mesh.
6. Agitating.
7. Filtering solutions.

The bugaboo of dry crushing and the prejudices against it are readily excusable if one considers the many attempts with the old jarring rolls and the endless trouble with screens and elevators, not to speak of the dust nuisance. But improvement in dry-grinding machinery has kept pace with other metallurgical improvements, and as we have taken from the cement works the tube-mill, so may we find there our intermediate grinder. I refer to a new class of ball-mill called the kominuter manufactured by F. L. Smidth & Co. This mill has been successfully used in many of our new cement plants. Their large capacity per horse-power consumed cannot be equalled by the best of our stamp-mills crushing wet to the same mesh, and, being self-contained, the dust is almost negligible and easily controlled. In one large cement plant in which these mills have been used for three years the costs for the year 1906 were \$0.0107 per bbl. of 380 lb. taking a feed of hard clinker passing 1½-in. ring and grinding to pass a 20-mesh screen.

In a personal communication from John Tait Milliken, superintendent of the Golden Cycle mill, at Colorado Springs, where four of these machines were installed, he informs me that during the time they ran prior to the fire they obtained a "capacity of 17,000 lb. per hour for each mill when fed with a product that had been reduced by rolls to pass through an opening 1½ in. diam." (revolving screen ¼-in. steel plate). These were No. 66 kominu-

ters and "were equipped with a diagonal slotted screen, size of opening $\frac{5}{32}$ by $\frac{1}{2}$ in. No. 8 steel plate. This opening gave a product varying in size from $\frac{1}{8}$ -in. cubes to the finest slime and when discharging this product at the above-mentioned tonnage, the consumption of power was 50 hp. at a speed of 22 r.p.m., the ball consumption being fourteen 5-in. forged steel balls weighing about 19.5 lb. each per day of 24 hours." Mr. Milliken estimates that "one man per shift can operate and carefully watch six or more of these komnuters," and that the liners will last about two years. R. N. Diggles, metallurgist, who visited the Golden Cycle mill just prior to its destruction, tells me that they gave no difficulty from dust.

With these facts before us, may we not stop and consider before rejecting dry crushing?

The next step in our scheme is roasting. In the past, roasting has had two main objections, high costs due to expense for fuel and labor, and unreliability as regards the product, for cyanidation, above all other processes, requires a perfect roast. The prejudice against roasting is probably due more to imperfect roasting furnaces and the many resultant failures in the past than to any other cause. Many of the furnaces that gave most satisfactory results for smelting failed utterly when tried at the cyanide plant. But there are one or two furnaces that have been perfected in Australia and which are now rapidly finding favor in this country and Mexico. I refer to the Edwards and Merton furnaces.

On samples of roasted concentrate taken from the Edwards furnace at the Eagle-Shawmut mine, in California, the roasts were so perfect that less than a pound of lime was required to neutralize the acidity. This concentrate before roasting carried 35% sulphur and after roasting the calcines contained less than 0.25% sulphur. This was accomplished in a 57 by 6 ft. tilting furnace roasting 9 tons per 24 hours and using $13\frac{1}{3}$ gal. fuel-oil per ton of concentrate.

At the Golden Cycle mill four of these furnaces of the Duplex style were operating most satisfactorily and four additional ones, I understand, are to be added to replace other types formerly used. Mr. Milliken favors me with the following data: "Each furnace has an effective hearth-area of 111 by 13 ft. The average sulphur content of ore fed to furnace is 1.8%. Each of these furnaces had an average capacity for the month of July of 107 tons per day of 24 hours, and required 280 lb. lignite coal per ton of ore roasting down to 0.11% insoluble sulphur, and 0.45% soluble sulphur. For the four furnaces the consumption of power was 15 hp. and required the services of one man per shift of eight hours for firing. So far as we can see from our period of operations the repair should not exceed, under ordinary conditions, five cents per ton."

The Merton furnace has also been quite successful in Australia, but I have no data in regard to it. However, I imagine that the dust lost in a Merton would greatly exceed that of an Edwards, in which it is almost negligible. Certainly the Edwards shows up well and answers all our requirements.

We have still to consider the cost of fuel. I take it that Cali-

fornia oil is the cheapest fuel delivered at Goldfield, and though I have heard it stated that oil could not be obtained at any price, I have secured quotations on a two-year contract basis, delivered in carload lots f.o.b. Goldfield, and guaranteeing deliveries at the rate of 150 bbl. per day at \$2.75 per barrel. Taking the heat values of lignite coal as used at the Golden Cycle mill, this would mean one-third of a barrel of oil per ton of ore. This is slightly in excess of the amount used at the Eagle-Shawmut on heavy concentrate with the small furnace. Assuming this to be correct, the fuel cost would be about 90c. per ton of ore; 35c. additional should easily cover power, labor, and repairs, or a cost of \$1.25 per ton for roasting—which can hardly be considered prohibitive.

From the roasters, after cooling, it will be necessary to re-grind to 100 mesh. For this the choice of machines probably lies between the tube-mill and grinding pans of the Wheeler type. Metallurgists are divided as to which is the most suitable for re-grinding roasted ore. Australian practice seems to favor the pan, but this is probably due to the desire to amalgamate while grinding in order to eliminate the coarse gold. This brings up the question of Viator* : "How to treat ores carrying some coarse gold as well as fine gold."

In the discussion on the 'Treatment of Desert Ores,' *Mining and Scientific Press*. August 25, 1906, I then advocated the elimination of amalgamation from the scheme of treatment whenever it was found necessary to fine-grind the ore to obtain the maximum profitable extraction and, to prove my contention, I gave the results of some tests conducted at that time. Since then I have had occasion to test the same thing on many ores and have as yet found no instance where I could not obtain just as high an extraction by fine-grinding to 100 or 150 mesh and direct cyanidation, as the total extraction obtained by both amalgamating and cyaniding. To give a particular example: Last summer I was working on a very rebellious ore containing coarse gold as well as fine gold. The ore consisted of a gangue of quartz containing about 5% arseno-pyrite and considerable arsenious oxide. It resisted all attempts at treatment raw, including amalgamation, concentration, and cyaniding. Roasting was therefore decided upon. After roasting at 10 mesh it was leached for four days, washed, then re-ground to 60 mesh, amalgamated, and concentrated to save any heavy oxides containing value. In this ore some of the gold particles were so coarse that they could be picked up with pincers, but they resisted amalgamation (due to a coating on the gold) and it was found to give a higher extraction when amalgamation followed rather than preceded cyanidation.

By this method the ore assaying 3.67 oz. gold per ton gave a final extraction of 96.1%, the residue assaying 0.15 oz. worth \$3.10 with a cyanide consumption of $\frac{3}{10}$ lb. per ton of ore.

Another test without amalgamation and concentration, but re-grinding the roasted 10-mesh ore to 100 mesh and agitating for 12 hours with 0.25% cyanide solution gave an extraction of 98.8%, the

*See p. 63.

residue assaying 0.045 oz. gold worth \$0.92, with a cyanide consumption of 0.4 pounds.

It would seem to me, from these and many other tests, that amalgamation is only an added expense if fine-grinding is to be resorted to, and this being so the tube-mill offers more advantages than the pan, especially for large installations. I should take my cooled ore, feed direct to my tube-mill with full strength cyanide solution, and in the great majority of cases it would be unnecessary to grind finer than 100 mesh to obtain a maximum extraction.

This brings us to the agitators. Of the many means and appliances for agitating slime nothing appeals to me, for cheapness and simplicity, so much as the air-lift pump set in a conical-bottom vat. Under these conditions the air-lift is working at its maximum efficiency, that is, the down-take is practically equal to the up-take. This system is too well known to require description and has been successfully installed to agitate not only slime but heavy concentrate finely ground. It presents the advantages of having no moving parts and requiring a minimum of power.

From the agitators we come to the subject of filters. At present the vacuum-filters seem to find favor in America and Mexico, though C. W. Merrill has accomplished wonders with filter-presses at the Homestake.

There are several good vacuum-filters on the market, such as the Moore, Butters, Kelly, and Ridgway, all of which do excellent work and would answer our requirements. But these filters have one serious drawback. As cloth is the filtering material used by them, at the commencement of each charge the filtrate is turbid and in many instances this turbidity persists all through the operations owing to the presence of a small hole in one or more of the filter-cloths. Also an incrustation of carbonate of lime accumulates on these filter-cloths and this progressively impairs their permeability. For efficient working, therefore, a subsidiary filter has to be used to clarify the solution, and the cloths have to be periodically pickled in acid to remove the lime incrustation.

A machine to which these objections do not apply, and which appeals to me strongly on account of its simple effectiveness and low first cost is the invention of Bertram Hunt. In its simplest form this consists of an annular chamber, which can be made of concrete, the top of which constitutes the filter surface. This filter surface is Hunt's well known triangular-slat-sand filter, carefully screened coarse sand being used. The inner and outer peripheral walls of the filter are continued three inches above the surface of the filter and constitute tracks on which a carriage revolves. This carriage has a scraper in front which removes the residue and is followed by a distributor for clean sand and one for the slime. Pipes distributing wash solutions and wash-water follow the carriage round the circle at proper distances. In operation, the pulp is preferably first roughly classified so that a portion of the sand in it is separated in a clean condition and this clean fine sand is fed onto the filter surface by the first distributor immediately behind

the scraper and the slimy balance of the pulp follows from the second distributor. In this manner the slime is always distributed over a filter surface of fine clean sand which is continuously renewed and removed. This, being a continuous machine, requires little or no attention after it has once been adjusted as to feed of pulp and speed of carriage, and a small part of the time of one man is all that would be required. A machine 16 ft. in diameter has a rated capacity of 50 tons in 24 hours and requires less than 1 hp. to drive and 4 hp. to maintain the vacuum. The machine complete can be installed for a small fraction of the cost of a machine of intermittent type of equal capacity and has the advantage that sand and slime can be treated together on the same machine and at a less cost for repairs, labor, and power.

This completes our process except the precipitation and refining of the bullion, and in this I would follow the usual custom of zinc-box precipitation.

Let us now make a rough comparison of the dry and wet methods. From the data given, I believe it will be admitted that dry-crushing in kominuters to 10 mesh will be as cheap, if not cheaper, than wet-crushing with stamps, and when it is considered that one of these mills complete, with feeders, liners, and balls, costs less than \$4500 f.o.b. factory, the comparison with the stamp-mill and its high cost of erection is still more in its favor. As against the cost of roasting we have the cost of concentration and the additional cost of marketing the concentrate. According to my tests 58% of the assay-value could be saved by a series of reductions and concentrations (and this, owing to the careful adjustments necessary and the close attention required, is not always obtainable in the every-day working of the mill). Of the 58% the smelters will pay but \$19.50 per ounce of the gold contained as against \$20.67 per ounce if shipped as bullion. This is equivalent to 95% of the value, that is, 5% of the 58% must be deducted from the total recovery of 92%, which reduces it to 89.1%, a total difference in the extraction as compared with the method I propose of 8.5%, which on \$50 ore amounts to \$4.25 per ton. To this must be added a freight and treatment charge of at least \$35 per ton on 8.9% of concentrate, amounting to \$3.10 per ton of ore, or a total charge against the wet method of about \$7.35 above the actual cost of treating the ore. As against this the principal additional cost by the dry method is the cost of \$1.25 for roasting. There is also to be considered the greater capacity of tube-mills grinding 13% less weight (loss in roasting) on material made softer by roasting.

In advocating a process against which such strong prejudices have been entertained, I have felt it incumbent upon me to go quite fully into details.

LOCHIEL M. KING.

San Francisco, December 16.

(February 22, 1908)

The Editor:

Sir—The discussion started by Mr. Browne has borne good fruit in that it has elicited the able and comprehensive article by Mr. King appearing in your issue of January 25. The method of treatment of Goldfield ore advocated by Mr. King is not in any sense experimental and has proved to be best in Western Australia, where the conditions as to high cost of power, water, and fuel were similar to what they now are at Goldfield. The same method is in use at the Golden Cycle mill, where they treat Cripple Creek ores. This mill is a custom plant depending on the extraction and economy of treatment for its profits, and works ores for a freight and treatment charge of \$4, of which \$1 is freight. At Mercur they mine and mill their ore for a few cents over \$3 per ton. The tests made by Mr. King, the results of which are given in his article, prove that Goldfield ores are perfectly suited to this method of treatment and it is difficult to understand what objections can be held against it.

It is reasonable to state that the best method is that which extracts the gold in one treatment and with the simplest machinery. The mills in Nevada, however, seem to be designed to extract the gold and silver in as many forms as possible and each one may be said to be an epitome of the history of ore treatment. Amalgamation followed by concentration and then by cyanidation represents the order in which these processes came into use and is the order in which they are used in the mills.

Regarding amalgamation, Mr. King's results show an extraction of only 4.2% by amalgamation on the raw sulphide ore. On the roasted ore the extraction by amalgamation was 44.67% and subsequent concentration and cyanidation brought up the total extraction to 91.17% at 30 mesh. Direct cyanide treatment at the same mesh yielded the same extraction. His further results at 100 to 150 mesh show that the gold in the roasted ore is quickly and completely dissolved by cyanide. These results tend to prove that, contrary to the general belief, roasting does not cause the gold to become coarse or run into beads when the telluride is decomposed. Gold telluride melts at a low temperature, below a red heat, and when a rich specimen of telluride ore is roasted, the melted telluride runs out on the surface and the tellurium is oxidized, metallic gold being left. This gold looks exactly as if it had been melted, but on examination it is found to be porous or spongy. I once took a piece of this porous gold resulting from the roasting of a rich specimen of Cripple Creek ore and placed it in an ordinary 1% cyanide solution and found that 70% of it was dissolved in a couple of days. However, as Mr. King has shown, in the case of a rebellious ore that actually did contain coarse gold, grinding the roasted ore to 100 mesh resulted in a practically complete extraction of the gold by cyanide; the presence of some coarse gold is a matter of no importance when fine-grinding is done. My answer to the question of 'Viator' regarding the treatment of ore carrying coarse gold as well as fine gold is, therefore, that, when fine-grinding is

done, the coarse gold will be ground fine along with the gangue and dissolved in the cyanide without any difficulty. Owing to the great cheapening of the cost of fine-grinding by the use of tube-mills and the improvement in the filtering and washing of the fine pulp by modern filter-machines, fine-grinding will be used in the majority of mills. Amalgamation will be unnecessary and only a needless expense. In the few instances in which it may be better to extract the coarse gold by amalgamation, amalgamation should follow cyanidation and the processes should be kept separate.

As regards the roasting of ore in localities where fuel is expensive, some means should be adopted to reduce the cost of fuel. When it is remembered that the roasted ore is discharged from the furnace at a temperature approaching 800° C., it is obvious that if a fair proportion of that heat could be returned to the furnace, an economy in fuel would be effected. In all cases the hot roasted ore passes through some cooling device, but it is generally some water-jacketed arrangement, and the heat abstracted from the ore is lost. It would seem to me that a simple heat-exchange device could be used by means of which the ingoing air could take up a portion of the heat from the outgoing roasted ore and so return it to the furnace. By extending the hearth a sufficient distance beyond the finishing hearth and by keeping the arch as low as possible, the air entering the furnace at the discharge can be made to abstract heat from the hot roasted ore. The economy effected by the return of this heat to the furnace will amount to about 25%, but there is the additional advantage of using pre-heated air for the combustion of the fuel. In a modern lime-kiln where the air is pre-heated by means similar to the above, an economy of 30 to 35% has been attained.

It has been the practice in chlorination works for a number of years to crush only to 10 or 12 mesh before roasting and to grind as fine as required after. This is, for many reasons, the best practice and I think the principle should be further extended. Preliminary tests should be made to determine how coarse the ore could be left compatible with getting a 'sweet' roast in a reasonable time. In the majority of instances this will be found to be much coarser than is generally supposed and possibly a quarter-inch size will be found fine enough. Drying of the ore would only be necessary in exceptional cases and the crushing could be done cheaply by jaw-crushers. As roasted ore is much more friable than raw ore, this would mean a big reduction in the total cost of crushing and grinding. The decrease in the tonnage to be ground for the same output of bullion (owing to the loss of weight in roasting), the greater friability of the roasted ore, and the advantage in filtering of having a pulp free from hydrated silicates should be credited to roasting and the saving effected deducted from the cost of roasting as compared with the treatment of the raw ore.

With the greatly increased use of fine grinding during the last few years the filtration of the pulp has become a question of increased importance and has brought forth a large number of filter-machines, all of them using canvas as the filtering substance. As

referred to by Mr. King, the incrustation of carbonate of lime on the canvas is a great drawback, and I am reliably informed that at the plant of Charles Butters at Virginia City, two men are employed all the time to take out the filter-leaves, treat them with acid, and return them. To the majority of people a sand-filter consists of, first, a layer of coarse gravel, then one of fine gravel, then one of finer gravel, and then one of sand, in all about a foot or so thick. The impression is also general that fine slime will pass through a layer of sand. The fact is that a layer of clean sand an inch thick will, if properly supported, form an efficient filter for the finest slime. I first used the triangular-slat-sand filter in 1888 for the drainage of sewage sludge. In 1894 these filters were put in the plant treating tailing from the Vulture mill at Wickenburg, Arizona. They remained in constant use for about two years and were not cleaned once during that time. One advantage of a sand-filter is that the filtering material is always on hand at the mill. When canvas is used a large stock has to be kept on hand and much inconvenience may result from the delay of an expected shipment.

Mr. King's article is especially valuable in that it gives the results of original work carefully and systematically performed, and it is to be hoped that others will publish results that they have obtained to the improvement of this branch of metallurgy.

BERTRAM HUNT.

San Francisco, February 5.

The Editor:

Sir—Referring to Loehiel M. King's article on this subject in your issue of January 25, I do not doubt the presence of tellurium in small quantity in the high-grade ore from the Mohawk mine of the Goldfield Con. Mines Co. In fact, I stated as much in my communication (issue of January 11). I still maintain, however, that there is not enough tellurium present in the milling ore now exposed in Goldfield (in the properties of the Goldfield Con. Mines Co.) to interfere with milling treatment by wet methods; and that the tellurium found in the higher-grade ore from the Mohawk mine is not in sufficient quantity to justify roasting in a large mill designed to treat milling ores from all of the Consolidated properties.

EDGAR A. COLLINS.

Tonopah, Nevada, February 6.

(June 20, 1908.)

The Editor:

Sir—Since the appearance of Mr. Loehiel King's article in your issue of January 25, I have had an opportunity of making actual mill-runs on about 700 tons of the sulphide ores taken from the lower levels of the Combination and Mohawk mines, at Goldfield. This was selected as representative of the lower-level sulphide ores, and represented an average of what the new mill of the Goldfield Consolidated would have to treat for a long time. It consisted of a mixture

of hard and soft talcose ore, the hard portions showing the sulphides very finely and evenly disseminated throughout the matrix.

This material was treated by our usual methods at the Combination mill, which was originally designed to treat oxidized ore. The results are summarized thus:

	Tons.	Gold, oz.	Per- centage.
Wet ore	506.57
Moisture	5.8
Dry ore	477.19
Crushed per stamp-hour.....	0.26
Average assay	1.77
Total gold contained	844.62
Total recovery by amalgamation.....	226.54
Extraction by amalgamation.....	26.82
Sand concentrated	117.10
Concentrate produced	10.01
Assay of concentrate per ton.....	14.01
Slime concentrated	360.75
Concentrate produced	8.37
Assay of concentrate	16.54
Total gold recovered by concentration.....	279.00
Extraction by concentration	33.04
Sand leached by cyanide	107.29
Assay of sand heading	0.794
Assay of sand tailing.....	0.104
Extraction from sand by leaching.....	86.90
Slime treated by agitation.....	351.70
Assay of slime heading.....	0.72
Assay of slime tailing.....	0.13
Extraction from slime	80.93
Total extraction by cyanidation.....	32.91
Total extraction by amalgamation, concentra- tion, and cyanidation.....	92.77

The stamps weigh 1200 lb. apiece, they drop 5½ in. at the rate of 108 drops per minute, and the discharge is through Tyler double-crimped 16-mesh 22-gauge wire-screen. I give a battery-discharge screen-test, so that some idea may be gained of the physical nature of the ore.

Mesh.	%
Held on 40	9.9
Held on 60	14.0
Held on 80	5.6
Held on 100	7.9
Held on 150	3.6
Held on 200	1.2
Passed 200 (sand)	2.7*
Passed 200 (slime)	54.9*

*Determined by a rising current of water.

The average time of leaching with weak solution was 9 days; with strong solution, 5 days; so that the total time was 14 days. The weak solution contained 0.8 lb. KCy per ton and the strong 3 lb. per ton. The consumption of KCy was 1.08 lb. per ton of ore treated.

The average time of agitation was 14 hours and the strength of cyanide solution 1.5 lb. per ton; the consumption of cyanide being 1.2 lb. per ton of ore. All samples were taken at 15-ft. intervals

throughout the test, at the head and tail of each step in the process, and careful screen-tests were made of all the samples and each size assayed, showing where the gold lay, before and after treatment by each process.

This test showed plainly what could be done with the inadequate facilities at the Combination mill, and also indicated what could be expected from a properly equipped plant, to treat the ore by the method outlined in the test. It is apparent that, physically, the ore lends itself readily to wet-crushing. When carrying 5.8% moisture, 57.6% passes 200 mesh when stamped through a 16-mesh screen at the battery. This shows the soft nature of the ore. Both of the conditions are inimical to dry-crushing in ball-mills, the moisture and soft material making it necessary to dry the ore, and the amount of soft material present-retarding the grinding effect of the mills on the harder material. The stamp-duty is shown to be large, and the mechanical results justify the stamps. By amalgamation, a recovery of 26.82% was made, as against 4.2% shown by Mr. King, and this could have been materially improved had our plate-area been larger. A saving of 33.04% was made by concentration, this being represented by 18.4 tons of concentrate, or 3.85% of the total ore treated. It was shown that practically no extraction had occurred on the material held on a 40-mesh screen, by either amalgamation or concentration, and but 45% extraction on such material as remains on 80-mesh. It was demonstrated that all material should be ground sufficiently fine to pass 100, or 150, mesh to obtain the best results. By such fine-grinding a large increase in the gold saved by amalgamation is obtained, by reason of which the concentrate will have a much lower value, and a larger portion of the sulphide will be liberated, allowing better concentration, with a residue more free from sulphide for cyanidation. This calls for large plate-area and proper concentrating facilities, neither of which were available during the test.

In the treatment by cyanide, the same conditions affected the extraction, that is, sand coarser than 100-mesh, and fine sulphide slime, due to poor concentration. The sand finer than 80-mesh and coarser than 200-mesh represented 47.7% of the product leached, and on this production the extraction was 97.36% of the original gold content of the ore. This product between -80 and +200 mesh was such that the proper comminution for the best extraction had been reached and the free gold and sulphide liberated, allowing of the best amalgamation and concentration, and there is no reason why as good results should not be obtained on the product coarser than 80-mesh if ground sufficiently fine.

The following is a screen-test on the sand-tailing after leaching:

Mesh.	%	Gold, oz.
Held on 40.....	0.1	0.19
Held on 60.....	8.8	0.14
Held on 80.....	10.5	0.11
Held on 100.....	20.5	0.04
Held on 150.....	24.0	0.05
Held on 200.....	3.2	0.05
Passed 200.....	32.5	0.114

Screen-test on slime treated by agitation:

Mesh.	%	Gold, oz.
Held on 100.....	1.4	0.06
Held on 150.....	3.3	0.08
Held on 200.....	1.1	0.08
Passed 200 (sand).....	3.9	0.16
Passed 200 (slime).....	90.1	0.18

On the material coarser than 200 mesh in this agitated product, an extraction of 95.77% was made from the original content of the ore, at the end of 14 hours' agitation and filter treatment. Several agitator-charges were sampled each hour during agitation, to determine the rate of solubility of the gold and the time necessary for agitation; the following is an average of results of such sampling:

Time of agitation. Hours.	Assay of pulp. Oz. gold per ton.
1	0.73
3	0.43
6	0.34
9	0.30
12	0.26
14	0.30
Extraction during agitation	58.9%

These special charges were sent to the storage-vats; the filter-charges made and treated separately. After the cake was formed the gold-bearing solution was displaced with a waste solution, carrying 0.4 lb. KCy and 6 cents gold per ton. The washing was continued with this solution for 45 minutes, with the following results:

	Oz. gold per ton.
Charge going to filter-box.....	0.30
After 45 minutes washing.....	0.132

Extraction in the filter-box was 23%, bringing total cyanide extraction on slime to 81.9%. While the results of the screen-tests showed what can be done with the material coarser than 200 mesh, it still leaves us with 76.78% of the total material stamped on which only 90.8% extraction has been made, but by careful concentration the same can be brought up 3.7%, making 94.5% extraction on this product with proper equipment. The deductions to be made, after considering the treatment of the ore by this method, to get the best results, are:

1. The ore to be stamped through as coarse a screen as possible to allow such material as readily forms slime, when crushed with water, to discharge as quickly as possible, and avoid sliming the harder particles. The battery-pulp to flow to classifiers for the separation of such slime and sand finer than 100 or 150 mesh; the coarser product going to the tube-mills. The total plate-area for amalgamation should be double the area ordinarily used, so as to allow of decreasing the velocity of the flow of the pulp over the plates to such a degree that the now fine sulphides will not unduly lag and retard amalgamation. Such area will also allow of some dilution (if the water applied in classification is not sufficient) to decrease the density, for, while the water may be ample for good

amalgamation, as ordinarily discharged with the pulp through a 20-mesh screen, such is not the case after all the pulp has been ground to pass 150 mesh. It will then carry a large amount of fine gold in suspension unless very dilute.

2. Ample concentrating facilities should be provided, which in this case also means area, and not an intricate system of classification, for we are dealing with fine sand and slime and the concentration does not have to cover a wide range of material. With our ores the slimed sulphide does not rapidly oxidize and become suspended on the surface of the water, as is often the case with the sulphides of silver, lead, and copper.

3. Large settling area should be provided, to allow of settling the slime and de-watering to the fullest extent, so that all reducing action by the water, in which the ore has been treated up to this point, may be removed. The agitator capacity to be such that after three or four hours' agitation the pulp may be allowed to settle and the supernatant liquor decanted for precipitation and the agitation again commenced with a precipitated solution. These decantations and changes of solution to be made as many times as may be found necessary.

Such a method of procedure is made necessary by the rapid reducing-action of the ore, as shown by the figures given in the agitation test mentioned (and many others that I have made). The gold goes rapidly into solution during the first hour of treatment, and then more slowly until finally it ceases entirely at the sixth hour of agitation, negative results being obtained for the remaining eight hours of agitation. It was also shown that upon removing the solution in which the slime was agitated and washing with a precipitated solution carrying 0.4 lb. KCy per ton, the gold was dissolved almost as rapidly as during the first hour of agitation.

From the large number of experiments made along the lines of the mill-run mentioned, I have no doubt but 95 to 97% extraction can be made on these ores of a \$50 value. Hence (but for the approximated 6% of concentrate, that we have on hand, still to be treated) our extractions are such that if commercially equaled, the roasting of the crude ore need not be considered. And the fact being that roasting gives good results by cyanide on the roasted crude ore, the same will also hold good in the case of the concentrate that can be roasted and treated at the mill at a cost not to exceed that of treating the crude ore. The fuel consumption should be less when considering the amount of sulphur contained, as shown by analysis.

ANALYSIS OF CONCENTRATE.

	%		%
Sulphur	41.5	Lime	Trace
Iron	35.9	Magnesium	Trace
Copper	0.64	Alumina	2.68
Lead	Trace	Gold	0.04
Tellurium and selenium.....	0.25	Silver	0.01
Bismuth	0.12	Arsenic	Trace
Zinc	0.19	Antimony	0.10
Manganese	0.04	Insoluble	18.30

In the matter of cost of operation of the two methods, for comparison, I give the following data in cents per ton of ore, on a basis of 600 tons per day by the wet method of stamping, amalgamating, and concentrating, as against drying, crushing, and roasting.

Cost of stamping.—Power	\$0.12
Supplies and repairs.....	0.10
Labor	0.0616
Total	\$0.2816
Amalgamation.—Supplies	\$0.03
Refining	0.011
Labor	0.10
Total	\$0.141
Concentration.—Power	\$0.022
Supplies	0.0165
Labor	0.0388
Total	\$0.0773
Tube-milling.—(5 mills, each 5 by 22 ft.) 248 tons of sand.	
Power	\$0.10 (2.1 lb. pebbles per ton)
Supplies and repairs 0.062 (4 in. silix lining once per year)	
Labor	0.026
Total	\$0.188
Equaling	0.0777 per ton stamped.
Roasting.—36 tons of concentrate at \$1.25 per ton equals 7.5 cents per ton stamped.	

These labor items include the services of a repair crew of four men, aside from the regular attendants.

Total cost (not including primary breaking) of preparing the ore for cyanidation is 65.26 cents per ton.

On the other hand, the cost of crushing crude ore in 'Kominuters' and roasting 600 tons per day is:

Operating 3 Kominuters.—Power	\$0.0666
Steel balls	0.0682
Labor	0.0200
Total	\$0.1548
No data on screen and weight of liners.	
Drying the ore.—(Six 100-ton drying furnaces)	
Power	\$0.0533
Repairs	0.03
Fuel	0.055
Labor	0.02
Total	\$0.1583

Roasting.—\$1.25.

Tube-milling.—(480 tons) \$0.1504.

Total cost (not including primary breaking) of preparing the ore for cyanidation is \$1.7135 per ton. No account is taken here of operation and maintenance of conveying and cooling apparatus, dust-chambers, feeders, and storage. No labor is added to the repair items.

The operating cost for drying, comminuting, roasting, and tube-milling is seen to be \$1.7135. For stamping, amalgamating, concen-

trating, and tube-milling, \$0.6526. A balance in favor of the latter method of \$1.0609.

When considering construction costs, there is no doubt but 100 stamps will greatly exceed the cost of three Kominuters; at the factory they only represent a small portion of the costs of the total necessary equipment in place, to complete the part of the process covered. For we have drying furnaces, Kominuters, roasting furnaces, coolers, storage-bins for feed to roasters and also tube-mills, conveyors, motor equipment of 700 hp., besides dust-chamber and stack. From the fact that the ore has been dried, twice the quantity will have to be tube-milled, making that item of installation double.

At the Golden Cycle mill, in Colorado, the dust-chamber, as nearly as I can remember, is 16 by 16 by 300 ft., with a 125-ft. concrete stack for eight Edwards furnaces. If this is necessary with the \$8 to \$10 Cripple Creek ores, it certainly would be with Goldfield ores assaying \$50 per ton.

Against this we have 100 stamps of 1050 lb. apiece, 40 sets of amalgamating plates, 80 concentrators, five 5 by 22 ft. tube-mills, one 36-ton roasting-furnace, with dust-chamber, stack, and cooler, and finally a motor equipment of 625 horse-power.

I have confined myself to a comparison of the apparatus; not having the cost and shipping weights of the roasting machinery, hence I cannot compare the two systems by actual cost, but think that it will be found in favor of the wet-crushing method. I fully agree with Mr. King, that the gold saved by amalgamation, when fine-grinding is resorted to, could also be recovered by the subsequent cyanide treatment, without the added expense, but I am a firm believer in the millman's motto: "Get your gold as soon as you can," and there are good reasons for doing so. By estimating our ore at \$50, and by making 28% extraction by amalgamation on 600 tons per day, we have \$8400 daily, already in the form of bullion. The chances of a material loss are greater the longer the gold stays in the plant, and the farther it is carried, especially when it is being carried by solution. There is some small loss each time it is handled, ether in the form of solution or precipitate. If simple amalgamation will decrease the value of your solutions by three or four dollars per ton, in addition to the other advantages mentioned, I think the additional expense is warranted.

As to concentration, I do not see any difficulty when contrating after tube-milling, as one treatment serves the purpose, without the series of concentrations and reductions mentioned by Mr. King. When crushing to 40 mesh such a series of concentrations and reductions would be necessary, as we have shown that practically 150 mesh is the liberation point of the free gold and sulphide. The 8% of concentrate mentioned by Mr. King probably contained a large amount of free gold, and sulphides in particles of gangue, which made the percentage of concentrate and values so high. The re-grinding of the 40-mesh sand again liberated an appreciable amount of fine sulphide, which made the series of concentrations seem necessary. Such series of reductions undoubtedly seem entirely proper to anyone

treating concentrating ores, where in most cases (the value of the ore permitting) comminution and concentration by stages is the only proper treatment to avoid heavy losses by sliming. Looked at from a concentration standpoint, my suggestion, of amalgamation and concentration after tube-milling, may seem the height of folly. But to illustrate to what degree these fine sulphides can be concentrated, even with the inadequate facilities during the test, I attach the following screen-test on the concentrate produced during the mill-test mentioned:

FROM SAND.			FROM SLIME.		
	%	Oz. gold.		%	Oz. gold.
Held on 40.....	0.95			
Held on 60.....	0.57	15.06			
Held on 80.....	1.05			
Held on 100.....	3.90	17.90	Held on 100.....	0.43	43.62
Held on 150.....	14.25	13.18	Held on 150.....	1.77	11.60
Held on 200.....	13.70	12.20	Held on 200.....	3.96	10.76
Passed 200	65.57	13.36	Passed 200	93.84	15.64

By fine-grinding and proper amalgamation, a large amount of fine gold is obtained that would otherwise be carried into the concentrate, largely increasing its value, which does not improve conditions even if it is expected to be treated on the ground, for reasons already explained, that is, the gold has to go through two or three more stages of treatment with a possibility of further loss. And as Mr. King has already explained, in the event of their being shipped to the smelter, only \$19.50 is obtained for considerable gold that should have been recovered by amalgamation, sent to the Mint, and settled for at \$20.67 per ounce.

The grinding to 150 mesh is also sufficient to insure the maximum liberation of the sulphides; with these ores, a better concentration can be made than would be the case if contending with a wider range of sizes of material. Treating these sulphides on the ground also removes the charge of \$4.25 against \$50 ore, and I think that by removing them by concentration and treating them separately, a much better extraction can be made than if they were roasted and treated with the ore. For changes in treatment can be made to suit the conditions for 36 tons of rich material that would be prohibitive when treating the whole 600 tons of crude ore, and I do not think that there can be any question that the roasted sulphides assaying \$398 per ton (as per Mr. King's test) would demand some different treatment to suit the conditions and obtain the best results, other than that given the roasted gangue. By assuming an extraction of 97.6% on such material, it will still leave \$11.70 per ton in the tailing, which does not appear to be much when expressed as 2.4% loss, but appears very different when expressed as \$11.70 per ton for 36 tons per day.

Before dismissing the comparison of cost and extraction, I think it well to call attention to the fact that we have been dealing with a quantity of 600 tons per day (the estimated capacity of the Consolidated new mill) at a value of \$50 per ton. It is reasonably well known that a mine that produces \$50 ore also produces a larger

quantity of \$5 ore, especially where the lode-channel is as wide and broken up as that of the Goldfield district. I might add as an indicator of what is expected to be done in the way of treatment, that the division line between 'waste dump' and 'suspense dump' of the Goldfield Consolidated Co. is about \$4. The item that fixes the value of the ore to be treated is cost of mining + cost of milling + the amount of profit demanded. So we shall "come down to earth" and make a comparison on a conservative average between high-grade and low-grade, and say \$15 per ton; then a difference of 8.5% extraction is equal to \$1.27 per ton.

Should the cost of roasting be the only addition, I think we are very close to the margin of economy, allowing that the roasting method will give the better extraction by 8.7%—something that it cannot do. The actual difference in the best results obtained by roasting and the mill-test given is 4.8%, which equals 72c. per ton on \$15, and the difference in cost between stamping, amalgamating, and concentrating on the one hand and the comminuting and roasting on the other, as I see it, is \$1.19 per ton, equaling 47c. per ton in favor of the former method, without considering that much better results can be obtained, with a mill properly equipped for this method of treatment, or that the extraction obtained by roasting was on ore assaying \$58.29 per ton, while those obtained in the mill-test was on ore assaying \$36.50.

If, as Mr. King has reason to believe, the greater part of the gold in the low-grade sulphide ore is present as a telluride, I must say that it is remarkably docile to treatment by amalgamation and cyanidation. Thus, 220 tons of the sulphide ore, of an assay value of \$24.80, were treated by amalgamation and cyanidation, without concentration, and gave extraction by amalgamation of 26.27 and 47.33% by cyanidation, making a total of 73.6%. This does not bear out such a supposition. And judging from the analyses of the concentrates and various tests that have been made, I should say that a very small proportion of the gold is present in the ore as a telluride. Referring to the agitation tests in Mr. King's article, where "the results were so poor that further efforts along that line were abandoned," I can say that while I do not think economical results would have been obtained without concentration, I do think that with two or three changes of solution during agitation, the results would have called for further investigation before abandonment, as the amount of H_2S evolved during agitation rapidly consumes all the free oxygen in solution, and any further extraction ceases.

Looking upon the extraction of gold from ore by cyanidation as an electrolytic process, it will be understood that the lack of oxygen to combine with the hydrogen soon causes a polarization of the solutions; in other words, giving a weak current in the wrong direction, either suspending any further extraction of the gold from the ore, or as the polarization becomes greater, precipitating gold from the solution. This reducing condition is very pronounced with the sulphide ores of this district, and mechanical means of applying oxygen is either only slightly effected, or not at all. After the first

supply of oxygen (carried in by the first solution) has been exhausted, the gold goes into solution very slowly, or only as fast as the solutions absorb oxygen to combine with the hydrogen in the solutions and keep the electro-motive force in the right direction. And where long periods of time are necessary for good extraction with these ores, the time is simply the measurement of the combining rate of oxygen with the solutions and has nothing to do with the solubility of the gold. Such gold as is soluble in the cyanide solutions in the ore will go into solution at a uniform rate until exhausted, the solution being maintained in the proper condition, and the fact that the rate of extraction gets slower and slower and covers a long period of time, does not mean that the gold is less soluble, but that the current is becoming more feeble, due to polarization. I find that the quickest way to remedy this condition is to remove such inert solution, and pass the same through the zinc-boxes. This has the same effect in the short space of time it takes the solution to go through the zinc-boxes, as a great many hours of agitation with all the aeration that can be given. In short, it is easier and simpler to remove the H_2S from the solution by precipitation than to furnish oxygen for the charge to neutralize it. Hence my reason for saying that the agitation-capacity should be such as to allow of this procedure with the Goldfield ores.

Were the ores of a hard quartzose nature, making a larger proportion of sand than slime, which would allow of easy access to the solutions throughout the cake in filter-pressing, the proper treatment would be to use the Merrill system and avoid agitation entirely. By it the water or solution (in which the ore has been crushed and which has been subjected to all the reducing actions of the ore) can be removed, and the highest efficiency of the oxygen can be obtained by blowing air under pressure through the charge, facilitating the combination of it with the hydrogen. A regulation of the flow of solution through the charge at the best rate of flow, commensurate with the best results must be made and as much solution as required can be passed through the charge.

To summarize: It is my opinion that there is no Goldfield ore, so far developed, that cannot be reduced more economically by the wet method, treating and roasting the concentrate on the ground, than by roasting and cyaniding the crude ore.

A. G. KIRBY.

Goldfield, Nevada, June 2.

CYANIDATION WITH THE BROWN VAT

By FRANCISCO NARVAEZ

(November 30, 1907)

The San Francisco mill is situated on a hill adjoining the El Sotol mine; it was designed for pan amalgamation and was transformed into a cyanide plant recently.

The ore is delivered to the bin of the mill from the Sotol mine by means of a portable track and little cars of 500 to 600 kg. capacity. Before dumping, the cars are weighed on a scale and samples are taken. The ore is broken to pass through a 1½ to 2-in. ring by means of two breakers of the Dodge type, and then it falls to the ore-bins behind the stamps. The mill consists of 30 stamps of 1050 lb. each, dropping 90 times per minute, through a height of 7 in., using Tyler double-crimped 16-mesh wire-cloth, and grinding at the rate of 2.8 tons per head per 24 hours.

The pulp from each battery is directly discharged, through a 2-in. pipe, onto a Wilfley table, making 250 strokes per minute. This separates about 15% of the gold and silver in a concentrate. The tailing falls into a launder leading to a conical hydraulic classifier. The overflow is sent directly through a 6-in. iron pipe to the Pachuca 'agitating tanks,' the underflow being elevated by means of a Frenier sand-pump to a battery of Boss pans for re-grinding. These pans have been discarded lately on account of bad results, and are likely to be replaced by two Krupp tube-mills. In the meantime the wire-cloth of the batteries have been reduced (so as to obtain a finer grinding) to 25-mesh of cloth of the same make.

The Pachuca agitating tanks, as they are called locally, were introduced in this district by Albert Grothe, who is the patentee, although the invention is credited to Mr. Brown of Western Australia. They are of steel, cylindrical in shape, and terminating in a conical bottom. (See Fig. 5.) The cylindrical part is 30 ft. high and the conical 15 ft., the diameter being also 15 ft., although those ordered for the San Rafael mill will be 20 ft. in diameter. On the inside and in the axis is situated a pipe which runs from top to bottom, 15 in. diam., within the interior of which and in its lower part a 1½-in. pipe ends, which is connected to the receiver of a compressor.

The vats are filled with pulp, the consistence of which has varied, but just now it has been found convenient to keep the ratio of water equal to that of ore, the excess water being decanted by overflowing through a 4-in. pipe, which runs on the top of the vats and connects them.

In starting a vat that has been filled, compressed air is applied through a pipe the valve being opened and closed immediately so as to give a blow that disturbs the whole mass of the pulp, which at the beginning of the operation is settled. Each blow of the piston admits a little compressed air, which, in expanding, forces the pulp up and disintegrates it. Repeated blows of air follow, until finally (the whole mass of the pulp having been disturbed) circulation takes

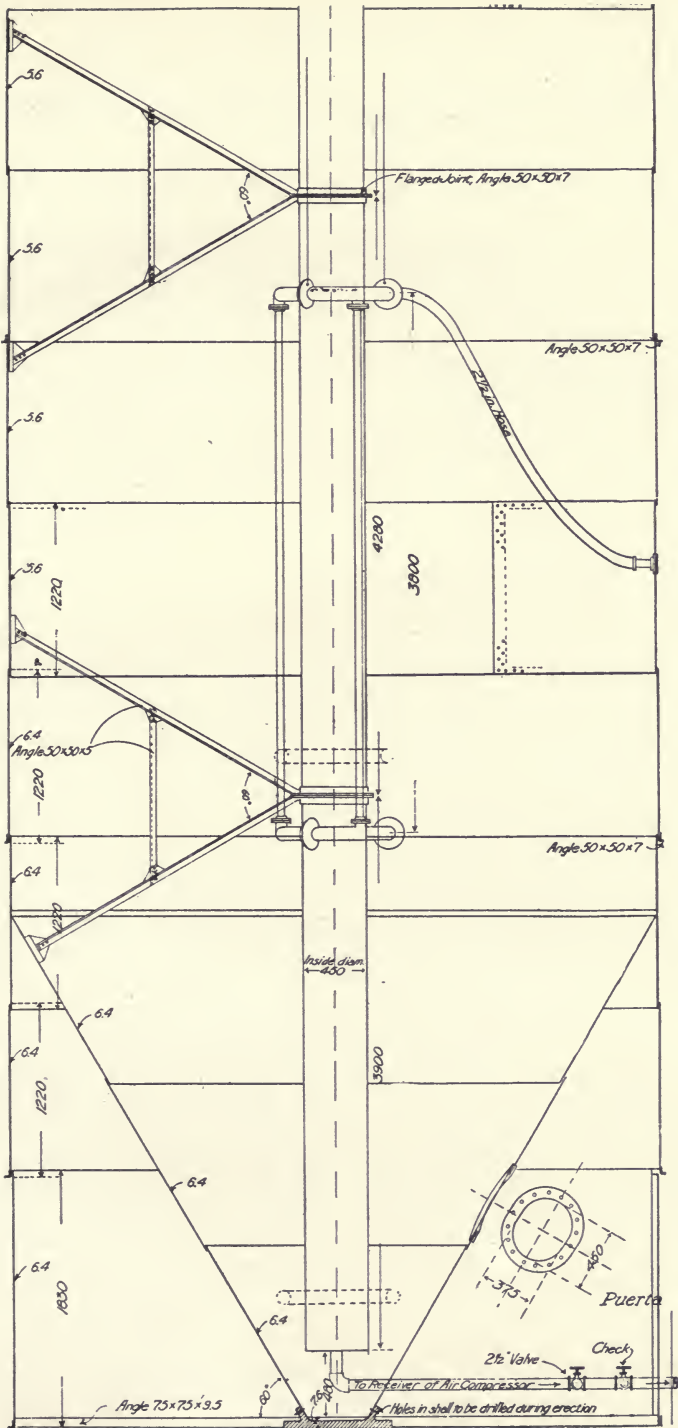

FIG. 5. LOWER PART OF BROWN AGITATING VAT

place; then the valve of the pipe needs but a little opening for keeping the mass in agitation, which at first sight looks like boiling water, so effective is the agitation.

The vat is really an air-lift, working under ideal conditions. This system of pumping requires a good submergence. As the mill has not been running continuously, mainly on account of the difficulties with the re-grinding plant, no available data are at hand indicative of the final results to be obtained by this system; but the following are the results of a test which was made on this mill for the San Rafael mine:

Weight of the ore treated, 96 tons of 1000 kilograms.

Assay in silver, 541 grams.

Assay in gold, 2.22 grams.

SIZING ANALYSIS OF THE PULP.

Mesh.	%
Plus 60	0.6
Less 60 plus 80.....	3.4
Less 80 plus 100.....	43.4
Less 100 plus 150.....	1.2
Less 150 plus 200.....	1.6
Less 200	49.4
	<hr/>
	96.6

Extraction in concentrate: 14.2% silver; 15.4% gold. The concentrate assayed 11.466 kg. silver and 44 gm. gold per ton. Grinding was done with cyanide solution 0.13 to 0.17% KCy, the strength of which was taken up to 0.3% during agitation, 130 grams of acetate of lead being added at that time per ton of pulp. Agitation took place during 48 hours, the proportion of pulp to solution being 1 to 1.47.

The pulp before going to the vats assayed 0.333 gm. silver and 1.6 gm. gold per ton. Samples were taken during agitation every two hours, the residues after 48 hours' agitation assaying 60 gm. silver and 0.2 gm. gold; this corresponds to an extraction by concentration and cyanidation of 88.9% of the silver and 91% of the gold.

The filtration of the slime took place in a Butters vacuum-filter, with 28 leaves. The general results have been satisfactory, although for a good running of the plant the filter wants to be at least doubled, because 28 leaves are not sufficient for the capacity of the plant.

A series of tests have been made personally by the writer on a little vat, which permits the treatment of samples weighing 50 kg., the results of which led to the immediate transformation of our present barrel-amalgamation plant into a cyanide mill.

CYANIDATION OF ORE CONTAINING BOTH COARSE AND FINE GOLD

(December 7, 1907)

The Editor:

Sir—The columns of your well known journal record the pioneer work done in the early 'nineties on the Pacific Coast by Almarin B. Paul, more especially the crushing in stamp-mills of gold ore with weak cyanide solution in place of water. It is somewhat surprising, therefore, that more attention has not been paid since then to the recovery by amalgamation or otherwise of the coarser gold particles in such pulp. While crushing with cyanide solution materially assists in dissolving the gold by means of the agitation, aeration, and thorough contact, yet gold particles of appreciable size do not completely dissolve within the practicable time limit of ordinary cyanide treatment, and are hence liable to be discharged with the residue unless some auxiliary method of recovery be employed. When the gold particles are fine enough to dissolve in a reasonable time, the necessity for amalgamation, of course, does not exist.

Among the published recommendations of a famous California millman—C. H. Aaron—prior to the discovery of the cyanide process, was the steady dripping into the mortar-box of cyanide solution to brighten the plates and gold particles in the ore being crushed. This feature alone would indicate a greater facility for gold amalgamation in a cyanide solution pulp than in a water pulp. The use of ordinary amalgamated copper plates for the above purpose is, however, subject to the disadvantage that both mercury and copper gradually dissolve in the solution and are re-deposited in the zinc-boxes, thus affecting clean-up and refining operations. Concentration of the pulp would no doubt serve to recover most of the coarser gold, but such an equipment seems cumbrous and expensive to install and operate, if solely for the purpose of recovering that fraction of the gold whose chemical and physical condition is such as to most readily insure contact and retention by a mercury surface. At present crushing with cyanide solution appears best adapted for the tube-milling of an ore which has been dry-crushed with rolls and which carries only fine gold. In this case amalgamation is not needed, the difficulty is minimized of accurately determining the value of the ore before treatment, and the small volume of solution in circulation reduces the danger of loss of soluble gold by leakages or overflows. It is to be hoped that the researches of the many skilled and progressive metallurgists of the Western mining States will develop a method of as satisfactorily dealing with a cyanide solution pulp carrying a portion of its values in coarse gold.

VIATOR.

City of Mexico, October 6.

[Prompted by this communication, we wrote to several cyanide specialists, stating the problem as follows:

“Given an ore containing some coarse gold, as well as gold

finely divided, what steps would you take to save the coarse gold, which otherwise will escape solution in cyanide?"

To this question we have received several replies, published below.—Editor.]

The Editor:

Sir—Replying to your question:

1. Should the coarse gold occur in some quantity and the ore is otherwise suitable for crushing in dilute solution, I would proceed as a first step to amalgamate it in the mills or batteries, and on copper plates. The small amount of mercury soluble in say 0.02% KCN solution will, as cyanide of mercury, greatly accelerate the solution of the fine gold as well as improve the precipitation of the precious metals in the zinc-boxes.

2. When the ore is crushed in water, plate amalgamation will usually take care of the coarse gold, while the separated slime and sand can be cyanided in the usual manner.

3. A satisfactory modification of 1 and 2 is to pass the ore, crushed either in cyanide solution or in water—but preferably the former—through a spitzkasten, so as to draw off the coarse gold with a small amount of concentrate. This product should then be ground and amalgamated in pans, and where the crushing is conducted in cyanide solutions the overflow from the pans can, after passing a precautionary settler, join the main mill-stream and pass direct to the extraction plant. In this way (No. 3) the amalgamation of the coarse gold, even in a large mill, can often be quite satisfactorily and economically conducted in, say, two pans. Further advantages might be pointed out, such as the benefit to be derived from the finer grinding of the concentrate, and where cyanide solution is the medium, much stronger solution than 0.02% may be used, without excessive mercury loss. Crushing in cyanide solution has come to stay, and with the additional feature of amalgamation, will take care of both the coarse and fine gold in the direct treatment of perhaps the majority of gold ores. I advocate strongly the removal by amalgamation of all the coarse gold instead of fine-grinding to render it readily soluble in cyanide. Plate amalgamation is quite feasible, but the solutions should not exceed 0.02% cyanide, otherwise both mercury and copper are too freely dissolved. Where crushing and amalgamation in cyanide solutions is practised, ordinary precautions must be taken against loss of solution. The mill-floors should be constructed of cement saturated with tar on the surfaces, or better still, of asphaltum, with, in either case, gutters to conduct all drainage to a central sump.

4. In dry-crushing mills, the coarse gold can be recovered from the leached sand.

(a) By sluicing them over riffles.

(b) By placing a spitzkasten in the tail-sluiice.

The concentrate from either (a) or (b) should be ground and amalgamated in pans or Chilean mills, as it will contain all the coarse gold.

I used the (a) method quite successfully for several years in a large dry-crushing and roasting plant. In that case the sluice was 300 ft. long, 20 in. wide, and set at an inclination of 1 in 16; the bottom was filled with iron riffles; 60 tons of sand and 100 tons of water per hour passed through the sluice. The riffles were cleaned up once a week, when the first 50 ft. usually gave 90% of the coarse gold in a concentrate carrying from 5 to 10 oz. gold per ton. The last 50 ft. of the flume did not show a trace of coarse gold but gave a concentrate of partly roasted ore, assaying about 0.15 oz. per ton. The total product from the riffles amounted to about 2% of the weight of tailing passing through the flume.

The final tailing discharged on the dump averaged 0.065 oz. gold per ton, but nothing further could be profitably removed by concentration, without finer grinding, as was amply demonstrated to certain parties who later erected a large plant of Wilfley tables, etc., at a cost exceeding \$50,000; this plant, however, being an unqualified failure, was dismantled and removed after a few months' trial of these dumps. I believe then, that the sluice and riffle must be admitted to be an effective means for the removal of coarse gold from sand, and under proper conditions I prefer it to spitzkasten. Blankets, sheep-skins, and such like are time-honored though antiquated means for catching gold and concentrate in flumes, streams, and on tables, so that a minimum quantity of material containing practically all the coarse gold can be submitted to a grinding and amalgamation process. Amalgamating all the crushed ore, when low-grade gold ores are crushed in cyanide solutions, is seldom either necessary or expedient. A riffle or spitzkasten concentrate will usually contain all the coarse gold not amenable to cyanide, and the cost and trouble of amalgamating 90 to 95% of the ore is eliminated. Along these lines I look for the next great advance in the metallurgy of gold ores. My ideas may be summarized as follows:

(c) The substitution of weak cyanide solutions for water in the crushing apparatus, circulating the mill solutions in a closed system.

(d) The removal of the coarse gold in a concentrate by riffle or spitzkasten.

(e) Amalgamating the coarse gold in pans and similar apparatus.

By 'coarse' gold in this article I mean metallic gold that by reason of its size or for other causes escapes solution in ordinary cyanide treatment. I further assume that it can be collected in a small amount of concentrate, and my experience shows this assumption is well founded.

PHILIP ARGALL.

Denver, October 14.

(December 14, 1907)

The Editor:

Sir—Referring to your query, I had the precise condition at the Smuggler-Union of an ore containing much amalgamable fine

gold but a larger amount of coarse gold, which was not amalgamable. After long and unsatisfactory experiments with various types of traps, we took pieces of 2 by 4, the length of the mortar lips, cut rectangular groove $2\frac{1}{2}$ in. wide by one inch deep the length of the 2 by 4, and closed the end, making a narrow trough. This was set at the head of each amalgamating plate where the pulp dropped directly into the trough from the mortar lip, thence overflowing onto the plate.

Once an hour the battery man went through the mill, picked up each of these troughs, inverted it, and struck it on the floor, knocking the contents out and replacing the trough. From this there resulted each 24 hours two half-barrels of highly concentrated pulp, which was then worked over a mechanical batea bought from the Allis-Chalmers Co. The bottom of this batea was always covered after such treatment with coarse gold, which was then fluxed and melted down into bullion.

Coarse and unamalgamable gold that gets into a concentrate is, of course, practically lost in the adjustments with the buyer, and the above is only offered as one method which got rid of a good deal of the difficulty.

C. W. VAN LAW.

Guanajuato, October 9.

The Editor:

Sir—The query is somewhat analogous to asking a doctor to prescribe for a person on the bare statement that he is sick. As the prescription would under such circumstances, if given at all, most likely be a physic, I am inclined to say: Amalgamate the coarse gold, this being the least apt to be wrong.

If the ore is stamped, and in water, plate amalgamation, with or without inside amalgamation, depending on the ore, the stamp-duty, and the shape of the mortars, would seem a reasonable thing to try, as it is so universally used for this exact purpose. If the ore is stamped in cyanide solution, copper plate amalgamation might still be the best way to get the coarse gold. We found it so at Bodie, and find it so at the Liberty Bell, though we have to renew our plates twice a year. Muntz metal I do not think much of. It will not catch the gold that copper will, and scours too easily, though it is not attacked by the cyanide solution to the same extent that copper is.

With large roomy mortars and granular heavy gold, enough might be caught in the mortars themselves, so as to render subsequent plate amalgamation uneconomic, particularly if the pulp were run through large pan-settlers of the Washoe type, after leaving the batteries. Were this done, a few flasks of quicksilver in the bottoms of the pans would help out wonderfully.

Pretty much the only remaining thing to do would be to try the merit of the idea advocated by the Denny brothers, namely, that of re-grinding the coarse gold in tube-mills along with the coarse sand, until it *will* go into solution. Tube-mills are certainly good

amalgam traps, and it would seem likely that the gold would be finely divided before leaving them. However, to answer the query categorically, I will say that I would try out the various ways of catching the particular coarse gold in question, and adopt the method showing the greatest economy from the combined standpoint of recovery and cost.

EDWARD H. NUTTER.

Telluride, Colorado, October 10.

(January 11, 1908)

The Editor:

Sir—Regarding your question:

Assuming that this ore does not contain any of the base metals in an amount to cause a high cyanide consumption, I would proceed to mill the ore in a weak cyanide solution (0.05 to 0.1%); passing over amalgamating plates; then classify by screening at practically 100 mesh; re-grind the oversize in tube-mills; again passing over amalgamating plates. After agitation, filter the slime, and precipitate the resulting solutions with a zinc method; zinc dust preferred.

WALTER L. REID.

Telluride, Colorado, December 28.

The Editor:

Sir—Answering your inquiry, I would amalgamate first and cyanide the tailing, which is probably the obvious answer to be given, not knowing the peculiarities of the ore, or other conditions which might influence the treatment. For example, I know of an instance of a mine equipped with a mill and an extensive cyanide plant in operation which preferred to grind up some of the ore that contained coarse gold to pass a 40-mesh screen and ship to the smelter in preference to amalgamating and cyaniding. The determining factor was the richness of this ore, which contained between 20 and 30 oz. gold per ton.

E. P. KENNEDY.

Treadwell, Alaska, January 2.

The Editor:

Sir—In reply to your question:

There are several ways that suggest themselves to me, among which are the following four, given in their order of preference:

1. Crush to 40 mesh, amalgamate in battery and upon apron plates, slime the whole product in Lane mills, and agitate with cyanide solution.

2. Crush to 20 mesh, amalgamate in battery and upon apron plate, size, leach the sand with cyanide solution, and agitate the slime.

3. Crush to 40 mesh, amalgamate in battery and over plates, size, leach the sand, and agitate the slime, both with cyanide solutions, of course.

4. Crush to 20 mesh, size, leach the sand with cyanide solutions,

and save the coarse gold on riffles placed in the discharge launders; agitate the slime with cyanide solution.

The matter of evolving the procedure under any one of these headings with the design of the necessary plant, can be perfected by any mining engineer or metallurgist, and need not be gone into at this time. In regard to the Lane mill, which I mention under heading No. 1, I can say that the foundry at Rapid City, S. D., manufactures what is called an improved Lane mill, in two sizes, and I can recommend it as an efficient fine grinder.

E. A. H. TAYS.

Denver, December 21.

The Editor:

Sir—The conditions described in your question probably obtain in the majority of gold mines, and certainly in all districts classed as free-milling; so that it would seem that the answer ought to be found in actual practice. With the same character of ore, approved practice will vary with local conditions, but roughly we may say that to save coarse gold we turn to amalgamation, for fine gold to cyaniding, for combined, alloyed, included, or otherwise rebellious gold, which even in a so-called free-milling ore, may amount to over 40% of the total value, to a variety of methods.

But the question is about the coarse gold. Are we confined to amalgamation, and if so, how shall we amalgamate?

Much of the coarse gold can be recovered by concentration, but the difficulty of sampling the concentrate makes this method objectionable unless the mine is doing its own smelting. Gold mines, however, are not apt to have their own smelters. Chlorination is apparently barred. We must amalgamate.

If the mine be in a district where there is an abundance of water, especially if there is no tailing disposal problem, the answer comes from many a stamp-mill, from Gilpin county to the Mother Lode, from Ontario to Alaska, each with its own local inflection. Varying in equipment and practice; in stamps, mortars, screens, and plates; in drop, speed, feed-water, and plate-grade, as determined by local experience, yet essentially they are the same, and their deep chorus is retaining from 30 to 70% of the assay-value, including practically all of the coarse gold, in the mortars or on the apron plates.

I say practically "all of the coarse gold," for I do not believe that an appreciable portion of it can escape in a rusty condition from the mortars of a properly designed and operated battery. Such coarse gold as goes beyond the apron plates will almost inevitably be caught in the amalgam traps, on the vanners, or on other concentrators. If not, we are forced to the rather Celtic conclusion that it is not coarse gold.

Where water must be conserved, and, to some extent, even where the only difficulty is that the disposal of the tailing is restricted, the advice coming from the Black Hills, from the arid Southwest, and

an ever increasing number of new districts is still to amalgamate for the coarse gold, but so long as the water must be separated, or recovered and pumped back, why not do the crushing in cyanide solution, for the cyanide is more efficient in the mortar than anywhere else.

Why does not South Africa join this chorus? That is another story. There the amalgamation recovery is so important that its efficiency must be the first consideration, and we must admit that a continuous feed of cyanide solution does not improve the character of amalgam or save mercury. Australia? Still another story, for here we have rebellious ore, much of it destined to roasting and grinding before final treatment. Really, when I started to answer the question it looked surprisingly elementary, but I find to cover it fully would really require a dissertation on the whole world's milling practice, so I shall have to let this suffice.

EDWIN C. HOLDEN.

New York, December 24.

(February 8, 1908)

The Editor:

Sir—In the issue of December 21, E. M. Hamilton suggests (See p. 73) re-grinding, with the idea that the gold would be either disintegrated or flattened into very thin plates. Undoubtedly there is a difference in the physical condition of gold occurring in different places, and it is possible that all gold might not yield readily to this treatment. This idea is suggested by an experience at Cooke City, Montana, where in one part of the mine we found free gold that failed to dissolve after four days' exposure to a 0.25% cyanide solution. The ore was crushed dry by rolls through 20 mesh, but an examination of the tailing showed that all of this gold would pass 60 mesh, and nearly all would go through 100 mesh. After the sudden rise in the value of the tailing due to the unexpected appearance of this free gold in a mine which had rarely shown a color, amalgamated plates were introduced into the sluice-boxes through which the tailing was discharged. Practically none of the gold was saved, and then different types of riffles, with quicksilver, were tried and proved unsatisfactory. Following this, blanket tables were used, a concentrate running up toward \$1000 per ton was obtained, and the tailing dropped back to an approximately reasonable figure. Possibly if this gold could have been put through a tube-mill and ground to 250 mesh it would have dissolved satisfactorily, but with our conditions, though it passed the finest screen we had, it would not dissolve.

GEO. A. PACKARD.

Boston, January 15.

The Editor:

Sir—If further discussion of your question regarding the treat-

ment of ore containing coarse gold is in order, I would like to offer the following suggestions:

I infer from Viator's communication that the crushing must be done in cyanide solution, otherwise amalgamation followed by cyanidation would be the natural course. Even when using cyanide in the batteries I believe the same plan is the best for the purpose, provided the solvent action of the cyanide on the plates can be avoided. This I think can be done in a simple way by making the plate the negative electrode of a galvanic couple, for it is well known that the cathode is not attacked by the electrolyte while the current is flowing. By making use of this fact we ought to be able to protect the plates from all action of the cyanide, and perhaps make them a little more active as amalgamators. The couple $Zn \rightarrow CuHg$ (amalgamated plate) gives a potential difference of 0.35 volt in a 0.1% solution, the current going in the solution in the direction indicated by the arrow, thus making the plate the negative element, or cathode.

Should anyone care to try the experiment I would suggest placing a few narrow strips of zinc along the edge of the plate, and insulated from it by a thin strip of insulating material. The strip of zinc and the insulator might be fastened to the plate with a couple of copper rivets, which would serve to short-circuit the couple and make the amalgamated plate the cathode, and thus protect it from the solvent action of the cyanide. The solution carrying the pulp over the plate would be the electrolyte, and the current would go from the zinc through the solution to the plate and back through the rivets, thus completing the circuit. The zinc should be bright and clean, as cyanide seems to have but little action upon ordinary rolled zinc.

I believe a few such couples around the plate would be sufficient to protect it from the action of the cyanide, and the amount of zinc going into solution from the anode would be so small as to be of no importance.

Should this method not give sufficient protection, another plan would be to use a carbon anode placed in some convenient position and just touching the pulp, and then pass a very weak current from it through the pulp to the plate and then back to the generator. Probably one ampere, or even less, of current would be sufficient for the purpose. By protecting the plate in this way any desired strength of cyanide could be used, which might prove particularly advantageous in the case of silver ores when a strong solution is necessary.

JAS. S. C. WELLS.

New York, January 18.

(May 30, 1908)

The Editor:

Sir—The numerous responses from well known authorities on ore treatment to my letter published on December 7 last over the signature of 'Viator,' encourages me to seek the hospitality of your

columns in order to offer a few comments upon the divergent suggestions made, and at the same time to express my thanks for the light which has been thrown upon the subject.

The broad form of query, to which you invited replies, has elicited a good deal of support for the method of crushing in water when the ore contains a considerable proportion of amalgamable gold, with subsequent treatment of the tailing only by cyanide. As pointed out by one contributor, the importance and efficiency of our amalgamation recovery has caused this system to remain common practice in South Africa. Those who advocate crushing ores of the class referred to, in cyanide solution, recommend the following methods for recovering the coarser gold:

(a) Use of amalgamated copper plates; their gradual dissolving to be regarded as an inevitable item of maintenance. No one, however, has dealt with the question of the copper from this source deposited in the zinc-boxes and its effect upon the clean-up.

(b) Use of spitzkasten for reducing the volume of pulp, to be subsequently ground and amalgamated in pans or similar apparatus. This method, of concentration before amalgamation, is hardly likely to afford as high an amalgamation recovery as when the whole pulp is amalgamated, since a very exact and constant regulation of the spitzkasten must obtain in order to prevent amalgamable gold, which cannot dissolve in a practicable time in cyanide solution, passing into the overflow. This difficulty also affects the recommendation of all-sliming the ore, and also presumably the gold, apart from the needless expenditure the latter course would necessitate in many cases, where sliming is not needed to expose the values thoroughly.

(c) Use of riffles for recovering the coarser gold. This method seems even less efficient than (b), and the re-working of placer sites, as at Oroville, shows how liable metallic gold of appreciable size is to escape this imitation of Nature's concentration methods. As in the previous suggestion, the high specific gravity of gold is alone relied on for its separation from a relatively deep stream of pulp, as compared with the combined effect of specific gravity and chemical affinity when the pulp flows in a broad shallow stream over an amalgamated plate. In applying both methods (b) and (c) to crushed ore after cyanide treatment there may be loss of particles of gold, whose original size was sufficient to ensure their recovery, but which by partial dissolution have been sufficiently reduced to be carried over in suspension in the pulp.

(d) Use of blanketings. No doubt, in the absence of more perfect and expensive concentrators, this device has very real merit in recovering tarnished or rusty gold, such as, even though fairly coarse, is not readily amalgamable either in a water or cyanide pulp.

(e) Only one reply deals with an expected suggestion of converting the amalgamated plate into a cathode, thus obviating solution of copper and mercury, while retaining the advantages of contact between brightened amalgamated surfaces and gold particles. Molloy's hydrogen amalgamator is based on this principle, but an even earlier suggestion, before the use of the cyanide process, is con-

tained in a series of articles on gold milling by C. H. Aaron, appearing originally in the *Mining and Scientific Press*, re-published later in the *Gold Fields News*, Barberton, Transvaal, in October, 1890. This author says: "I recommend that millmen who have trouble with their plates should make some experiments, each separately, as follows:

"1. Place some bars of iron on the apron, say one across the upper end, and one on each side edge, also one in the middle.

"2. Use zinc amalgam on the apron.

"3. Dissolve a little cadmium in the quicksilver for use on the apron and in the mortar.

"4. Fix a tank so as to deliver a small stream of water, containing potassium cyanide, into the mortar constantly while crushing. (This has been done in some mills with good effect.)

"Those who have occasion to work auriferous material in pans would do well to try a solution of potassium cyanide in which a little red oxide of mercury is dissolved; the effect of this solution is to coat every particle of gold with quicksilver, which greatly aids the amalgamation. Not too much of the solution must be used, as it dissolves gold; however, it is believed that the dissolved gold can be recovered by using zinc amalgam in the pan, toward the end of the operation. Before adding the solution, the pulp should be made slightly alkaline by the addition of a little potash or soda. It is believed by many that zinc amalgam is very effective in catching gold, and still greater efficiency is claimed for cadmium amalgam. The presence of zincblende in the ore has probably a favorable effect on amalgamation by tending to prevent oxidation of the plates, with which it forms a galvanic couple in the same way as does a piece of zinc."

W. A. CALDECOTT.

Johannesburg, Transvaal, March 23.

(July 11, 1908)

The Editor:

Sir—W. A. Caldecott, in his letter on 'Cyanidation of Ore Containing Both Coarse and Fine Gold,' published in your issue of May 30, quotes from an old article by C. H. Aaron (which, by the way, I have never seen) in which the latter advises millmen having trouble with their plates to place bars of iron on them, with the idea probably of forming a galvanic couple, thus making the plate more active as an amalgamator. On trying this combination, and using ordinary water as the electrolyte, I find that there is a feeble current of about 0.04 volt flowing in the solution from the iron to the amalgamated plate. Should the water contain any free acid, or soluble acid sulphate, a stronger current would, of course, be produced.

Later on he advises the use of a dilute solution of KCN in the mortar, apparently forgetting that this will reverse the direction of the current in his couple, and give a comparatively strong one (0.4 volt) from the plate to the iron, thus dissolving the plate instead of

protecting it. It may be that it was not intended to use the iron bars in this case, but even so there would, of course, be some solvent action on the plate. His suggestion of using zinc or cadmium amalgam is simply a substitution of these metals for the sodium in sodium amalgam, the use of the latter in amalgamation being, I believe, first proposed by Sir W. Crookes. The zinc or cadmium would be less costly than the sodium, but would probably be less effective. The method proposed in my letter of January 18, using zinc strips, would result in forming a certain amount of zinc amalgam, and perhaps would help the amalgamation to some extent.

JAS. S. C. WELLS.

New York, June 25.

(December 21, 1907)

The Editor:

Sir—Yours of October 2 is at hand. The question you put is difficult to reply to. To begin with, the form of the question is indefinite; the expression "coarse gold" is a relative one, and gold that would be coarse from a cyanide man's point of view might be classed as fine gold by the alluvial miner. Of course your inquiry refers to ore and not alluvium, but it is quite conceivable that there may be ore carrying gold which even the alluvial miner would call coarse. The real point, however, would seem to be, not the condition of the gold as it is in the ore, but as it is in the pulp after having been comminuted for purposes of extraction; this again would necessitate the assumption of some stated degree of comminution. Before trying to reply to your question I should prefer, with your permission, to re-state it more definitely, if I can, while still preserving what I take to be the fundamental point at issue. If in so doing I have failed to grasp the exact point at which you were aiming I hope you will put me straight.

"Given an ore which, after having been ground or crushed or otherwise reduced to a pulp sufficiently fine to pass a 26-mesh screen, still contains, as well as gold finely divided, particles of gold that are too coarse to be dissolved by cyanide solution within a reasonable time and by the methods in commercial use at the present day, what steps would you take to save the coarse gold, which otherwise will escape solution in cyanide?"

The principal difficulty I find in reply to this question lies in the danger, which I have often had occasion to note, of trying to generalize in regard to the metallurgical treatment of gold and silver ores. It seems to me that before one could make a pronouncement as to how best to deal with "coarse gold" it would be necessary to study the particular conditions of an individual case, and even then the conclusions arrived at would not necessarily be applicable to any other mine or ore whatever.

I suppose that the competing methods in such a case would be, on the one hand, plate amalgamation, with or without subsequent cyanidation of the tailing, and on the other, re-grinding or otherwise

finely subdividing the whole of the ore, or that part of it that accompanies the coarse gold, and cyaniding the whole without previous amalgamation. If you are disposed to doubt whether the latter is a legitimate and effective alternative to the former, I may state that I have personally had experience of instances where it has shown itself so to be. It is possible that there may be cases where the gold is too soft and pure to be readily disintegrated, but, if so, it would no doubt become flattened out into thin plates, which would be acted on by cyanide as rapidly as if it were mechanically subdivided.

To return to the first of my alternatives; I think that its adoption would rather depend on whether the gold, both coarse and fine, is easily detachable from the quartz, or in other words, it would depend on whether any considerable quantity of the gold was mechanically locked up in the quartz grains and therefore needed especially fine grinding to render it accessible. If, after plate-amalgamation and cyanidation of the tailing, the coarse sand did not contain sufficient insoluble gold to pay for fine grinding, then I should be inclined to declare in favor of my first alternative. If, on the other hand, the coarse sand showed sufficient residual inaccessible gold to indicate a profit on fine grinding, I should be content to recover all my gold by cyanidation alone.

It may be asked, why should these alternatives be considered mutually exclusive? Why should one not get all the gold possible by preliminary amalgamation, whether it be fine or coarse gold, and then re-grind, if necessary, prior to cyanidation of the tailing? The principal reason seems to me to lie in the difficulty of plate-amalgamation when crushing in cyanide solution. I am aware that some metallurgists have combined these two principles, but I think that the practice has not been widely adopted, and my own experience of it has not been encouraging. Moreover, if fine grinding be indicated at all, it is as easy to re-grind at one stage of the proceedings as at another, and if such re-grinding permits the cyanidation of all the gold that could otherwise be caught on the plates, why go to the extra trouble and expense of using plates?

Again, it may be asked, why crush in cyanide solution? Well, that is rather a vexed question, but I may state the fact, for whatever it is worth, that Charles Butters, after a plentiful experience of water-crushing, has deliberately adopted the practice of milling in cyanide solution in all the plants controlled by him, whether crushing ore from a mine or treating old tailing, and that this has been his invariable custom for at least seven years past. If I were asked what I considered to be the special advantages of this method I should say: First, the increased rapidity in the solution of the precious metals, which materially shortens the subsequent treatment and therefore reduces the size of the cyanide plant necessary for a given tonnage. This is especially marked in the slime portion of the pulp, where it is no uncommon thing to see from 70 to 80% of the gold contents passing into solution before treatment in the slime-vats begins.

The second great advantage I should ascribe to the method

would be the fact that the introduction of large quantities of water into the solution stock is thus avoided. It is obvious that, considering any cyanide plant as a whole, no more water can be taken into the system daily than is withdrawn from that system in the same period; consequently, if, with every ton of slime, we take into our plant a ton of water, then for every ton of slime residue discharged we must get rid of a ton of solution in some way or other. Some do this in the form of moisture in the slime residue; and others, who prefer to displace part of this moisture (which, be it remembered, is solution) by water, run to waste an equivalent quantity of solution from the tailing of their precipitation-boxes, so as to preserve the balance in the system. This difficulty is much accentuated where the slime residue is treated in filter-presses or vacuum-filters; it is to some extent mitigated where double filtering is practised, that is, where the excess water is extracted from the slime before cyanide solution is added, though even here, when the cake contains 25% of moisture, for every three tons of slime a ton of water is introduced into the system and a corresponding ton of solution has to be eliminated at some point, rendering it difficult or impossible to give a displacing water-wash to the residue cake without running to waste weak solution. It is bad enough to have to throw away solution carrying cyanide even when its gold content is nil or a 'trace,' but I fear that in too many instances that so-called 'waste' solution is the vehicle of serious gold-losses in addition to the loss of the contained cyanide.

In the foregoing remarks anent the use of cyanide solution in the mill I have allowed myself to wander rather outside the limits of the matter under discussion, but I must ask you to excuse this on the ground that it seemed necessary to explain the position I took up in regard to the point at issue. To return to the subject of your question, I am inclined to think that there is a tendency to exaggerate the difficulties in cyaniding caused by coarse gold. At the mine where I am at present engaged the ore contains a considerable quantity of visible nuggetty gold, but we do not seem to have any trouble on that account. We clean up some coarse gold periodically from our Huntington mills that has failed to pass an average mesh of about 25 holes per linear inch (several different sized screens are in use on different mills, and the coarsest of the sand issuing therefrom is re-ground in pans), but that is the only place where coarse gold makes its presence evident. The following is a representative screen-analysis of the sand portion of the pulp going to the cyanide plant:

Mesh.	%
+ 40	1.0
— 40 + 60	32.1
— 60 + 80	16.3
— 80 + 100	11.3
— 100 + 150	21.7
— 150 + 200	8.9
— 200	5.7
Slime	2.9

Concentration of this pulp has now been discontinued, but formerly it used to be passed over Frue vanners before going to the sand-plant. In the course of one of my experiments I took a sample of the resulting concentrate, which assayed \$348 per ton in gold (beside the silver, with which we are not now concerned). If there were any coarse gold liable to give trouble in the sand-vats it would surely be well represented in this concentrate, and yet three days' agitation in a bottle with cyanide solution sufficed to dissolve 95% of it without further grinding or sub-division of any kind. (The same concentrate when treated with the sand in the ordinary course without separation, yields about 97.5% of its gold content.) Now, even if the remaining 5% in the above experiment be considered to be all 'coarse gold' in the sense of our definition, and if in our actual treatment we did not succeed in dissolving more than was shown in this three-day bottle test, it would still only disturb the total extraction on our ore to the extent of 26c. per ton. It is more than probable, however, that this residual 5% of the gold in the concentrate was not all 'coarse gold,' but largely gold intimately associated with the sulphides.

With a battery head of \$8 or \$10 gold per ton the residue from the sand-vats will assay in gold as follows:

Mesh.	Cents.
+ 60	80
— 60 + 80	70
— 80 + 100	50
— 100 + 150	40
— 150 + 200	40
— 200	60
Slime	40

These assays would tend to show that 'coarse gold' is not the most serious of the problems we have to solve at this time.

E. M. HAMILTON.

Torres, Sonora, October 8.

THE BURT RAPID CYANIDE FILTER

By E. BURT

(December 7, 1907)

At the plant of the El Oro Mining & Ry. Co., after the erection of the second 100 stamps known as Mill No. 2, it was decided to treat all the sand and slime in the new cyanide plant, where they could be handled more advantageously with the larger units.

When this change was made, and with the aid of tube-mills for fine grinding, there were produced 550 to 600 tons of slime to be handled daily. This slime is handled entirely by the decantation process, and owing to crushing with cyanide solution in the batteries, a large amount of solution per ton of slime treated has to be precipitated daily. This amount is 9 tons of solution to 1 ton of slime. Of the five washes given to the slime, the first is mill-

solution collected with the slime, which with the next three washes are run to the precipitation boxes, while the fifth wash is run to the mill-solution vats. With all of this washing, and the slime being discharged with only 40% moisture, there was still a difference of 10 to 15 cents gold and one to two-tenths of an ounce silver between the sample of washed and unwashed slime-discharge. Aside from the loss in dissolved metal there was a small loss in cyanide.

With the idea in view of cutting down these losses, and also of treating the slime with a smaller proportion of solution per ton of slime, experiments were started to see what could be done by filter-pressing. After trying two different systems on a small scale it was decided to work out a system where gravity pressure could be utilized, and after a great amount of work and experimenting, a cylinder type of press was evolved.

This press, Fig. 6 and 7, consists of a cylinder pivotally mounted or set in a fixed position at an angle of about 45° , with a large door at its lower end. It carries a series of filter-mats, swingingly suspended in its interior, each mat having a connection which passes through the shell to a main solution-pipe fixed on its exterior. These mats consist of two sheets of heavy canvas enclosing a core of cocoamattin or burlap. The edges of the canvas are lapped over and sewed so as to enclose a perforated pipe bent in the shape of an ellipse. The ends of this pipe almost meet in a special T, which is held rigid against the interior of the shell, and the perforated pipe turning in the T allows the mat to swing. The door at the lower half of the end of the cylinder is of such dimensions that the opening is equal to one-half the area of the end. It is made large to allow easy exit of the slime without the use of much water. An 18-in. valve was used on a 3-ft. cylinder, and it was found that the hard cake of slime would bank up against the shoulders and not discharge. A door of liberal dimensions allows the changing of cloths without taking off the cylinder-head. The door is opened and closed by an arrangement of toggles operated by a hydraulic or air-cylinder. These work against a cross-head, which in turn is held in place by side-rods bolted to the head of the cylinder. On the bottom side of the cylinder near the door is placed the one connection for admitting slime, wash-solution, or wash-water, and for displacing any surplus slime or washes. There is a valve on the main solution-pipe on top of the press, and an air-connection to the pipe. To the top of the cylinder is fastened an air-connection. For operating the press the valves are so arranged with different connections for slime-feed by gravity from the surplus vat, or for wash-solution or water, that they can be operated by one man. To operate the press (referring to the accompanying illustration) the slime is forced in under a pressure of from 40 to 60 lb., until a cake of the desired thickness is formed on the mats. Then the slime-valve is closed and the air-valve and the discharge valve are opened. Air at a low pressure is admitted to the shell and forces out all of the soft slime, and at the same time this pressure keeps the cakes in place. All this material flows back to the slime-supply vat. The

discharge-valve is then closed and wash-water is admitted. After a sufficient length of time the wash-water is shut off and air is ad-

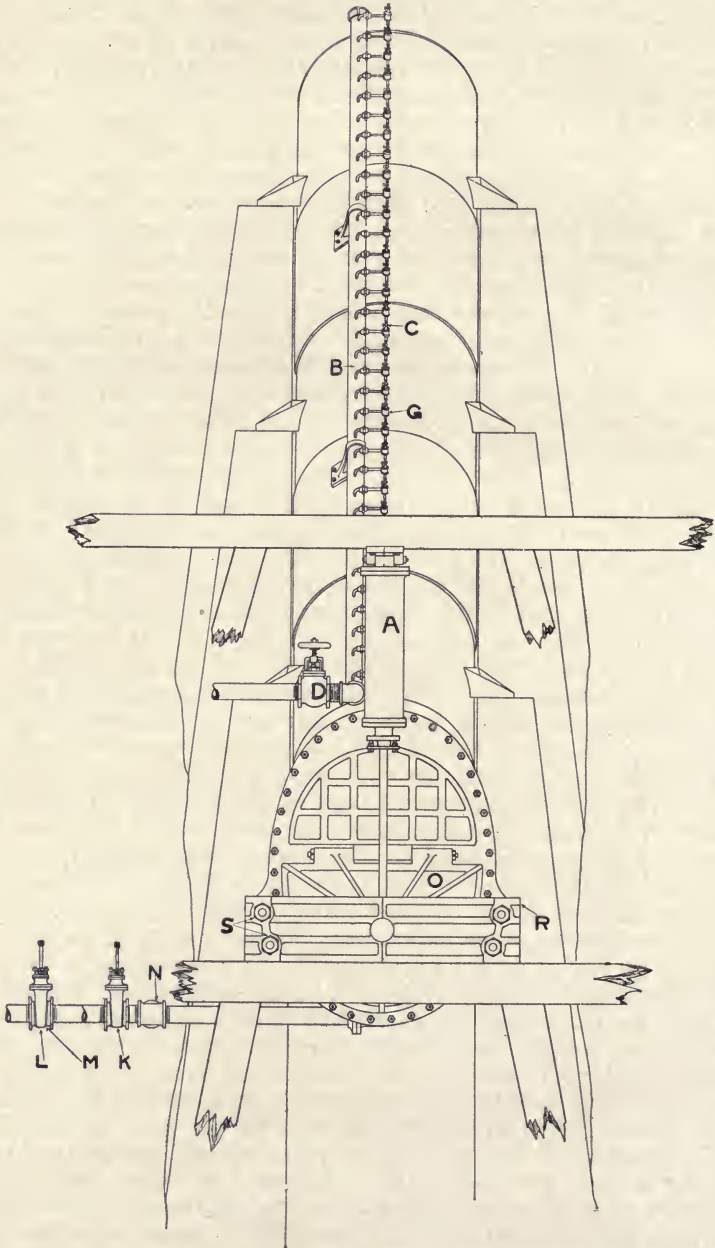

FIG. 6

mitted to the shell again, until all of the excess liquid is displaced, and a large part of the moisture in the cakes is driven off. The solution-valve is then closed and air at a low pressure is ad-

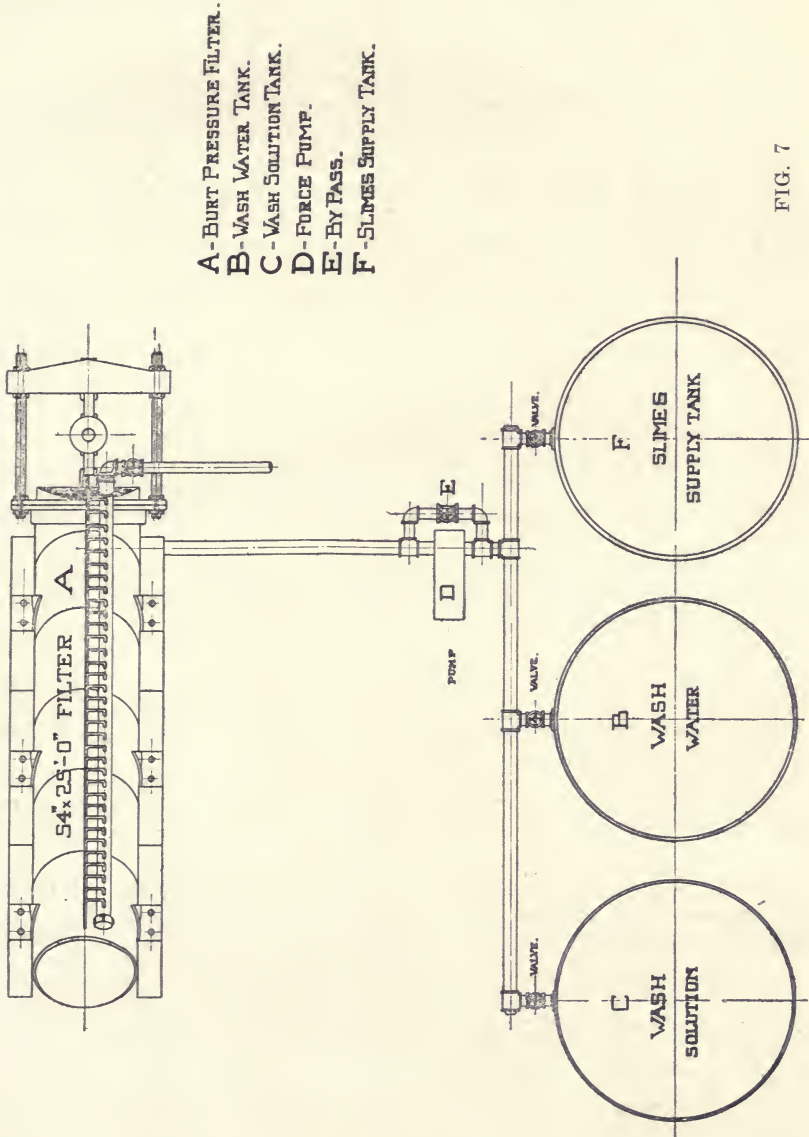

FIG. 7

mitted into the system of pipes connected with the filter-mats, thus causing the cakes to drop off and slide out of the shell. Before kicking the cakes off the mats the door is opened by means

of the hydraulic cylinder. The first and upward motion of the piston-rod draws the toggles out of position, and a continuation of this motion draws the door open sufficiently to allow the material to slide out of the shell. If the press is being operated by gravity pressure there is a small amount of surplus slime run to the vat. For the next operation this surplus slime is first pumped into the press, partly filling it, then the pump is stopped and the gravity slime-feed valve is opened and the operation carried on as before. Another method of operating is to fill the shell with slime and then shut the slime-feed valve and let in wash-solution, when all of the slime will form cakes; then the washing or treatment can be continued as long as desired. This wash-solution may be displaced with air, which gives an 'air leaching' to the slime, and then the washing may be continued again, if desired.

If a low air-pressure is maintained against the cake of slime it will not crack, but if the pressure is raised to 10 or 20 lb., or a 15-in. vacuum be maintained on a cake, it will crack. It has been found that an air-pressure of 10 lb. can be kept on a 1½-in. cake for 10 minutes, and then by introducing a slimy wash-water the slime will immediately fill the cracks, and then the washing proceeds as usual. Using a pressure of 50 lb. it requires about ½ minute to fill the crack in the cake, and to complete the total washing 15 to 20 min. The time occupied in filling the cracks is about ½ minute when using 50-lb. pressure.

The following data give the time of the different operations and value of wash-solutions coming from the cake, also washed and unwashed sample of residue:

Operation.	No. 1.	Minutes.
Forming cake		5
Displacing slime and entering wash-water.....		22
		<hr style="width: 10%; margin-left: auto; margin-right: 0;"/>
Total time		27

Cake 1½ in. thick, made at 75-lb. pressure; wash-water used per min., 60 gal. at 90-lb. pressure.

SOLUTION ASSAYS.

	Gold.	Silver.
Solution from making cake.....	\$1.66	0.4 oz.
Wash-water after 2 minutes.....	0.54	Trace
" " 4 " 	0.34	" "
" " 6 " 	0.28	" "
" " 8 " 	0.20	" "
" " 10 " 	0.10	" "
" " 14 " 	0.16	" "
" " 16 " 	0.10	" "
" " 18 " 	0.06	" "
" " 20 " 	0.04	" "
" " 22 " 	Trace	" "
Moisture out of cake.....	" "	" "
Heading	7.50	2.50
Tailing	0.52	1.95
Tailing washed	0.57	2.00

Moisture in cake 28 to 30%. Amount in one charge 1.75 tons.

No. 2.

Operation.	Minutes.
Forming cake	7
Displacing slime	4
Washing	20
Displacing wash-water and emptying.....	4
<hr/>	
Total time	35
Cake 1½ in. thick, made at 75-lb. pressure; wash-water used at 90-lb. pressure.	

SOLUTION ASSAYS.

	Gold.	Silver.
Solution from making cake.....	\$1.66	0.4 oz.
Wash-water after 3 minutes.....	0.64	0.2
“ “ 7 “	0.18	Trace
“ “ 10 “	0.12	“
“ “ 15 “	0.06	“
“ “ 20 “	0.02	“
Moisture in cake	Trace	“
Heading	7.50	2.50
Tailing	0.47	1.95
Tailing washed	0.57	1.90
Moisture in cake 28%. Amount treated in one charge 1.75 tons.		

No. 3.

Operation.	Minutes.
Forming cake	8
Displacing slime	3
Washing	15
Displacing wash-water	4
<hr/>	
Total	30
Cake 1½ in. thick, made at 75-lb. pressure; wash-water per minute 69 gal. at 90-lb. pressure.	

SOLUTION ASSAYS.

	Gold.	Silver.
Solution from making cake.....	\$1.66	0.4 oz.
Wash-water after 5 minutes.....	0.30	Trace
“ “ 10 “	0.16	“
“ “ 15 “	0.08	“
Moisture out of cake.....	0.10	“
Heading	7.50	2.50
Tailing	0.52	2.00
Tailing washed	0.52	1.90
Moisture in cake 29%. Amount treated in one charge 1.75 tons.		

The condition of the filter-mats can be readily told by closing the cock in the branch pipe, connecting to the solution-pipe, and opening the little pet-cock on top of the T. A battery of these presses can be operated as a single unit or separately; any one of them may be cut out to change cloths. The cloths last about six months and require acid treatment once a month. The life of the cloth may seem short, but when the following figures are examined it will be seen that each cloth has a large capacity from using a pressure of 40 to 60 lb., thus:

Size	42 in. by 20 ft.
Weight, in pounds.....	12,800
Capacity, in tons of dry slime per 24 hr.....	120
Number of mats.....	28
Area one side of mat, in sq. ft.....	8
Total volume of shell, in cu. ft.....	208.8

Total volume of mats, in cu. ft.....	6.3
Total volume of cake 2 in. thick, in cu. ft., moisture 28%, 110 lb. per cu. ft.	74.6
Total amount slime to fill shell, in cu. ft., moisture 60%, 82.2 lb. per cu. ft.	202.5
Volume of excess slime, in cu. ft.....	127.9
Volume to pump to make cake, in cu. ft., moisture 60%.....	134.0
Total volume to pump, in cu. ft.....	336.5

Operating expenses per ton of dry slime, 4 cents gold when using gravity-pressure, and 8 cents using pump.

The amount of surplus slime to be handled at each operation is 39% of the total slime run into the press.

The time of making a cake is so short that there is no settlement of the sandy portion, if there be any. After one or two operations, and measuring the cake, a definite number of minutes can be used as a criterion, so as to make the same thickness of cake. If the slime is very thick the cake will form quicker, but it will not be so compact as when made with a more dilute slime. The solution-filter is built on the same plan, except that there is no discharge-door, and the cloths are placed as close together as the connections will allow. The entire space inside the cylinder is occupied with cloths, except a few inches under the cloths to allow for sluicing out the thin cake that drops.

One of these presses, 54 in. by 17 ft., with 70 cloths, recently installed in the mill of the Mexico Mines of El Oro, has been filtering 2400 tons of solution per day for 30 days and has only been cleaned once, and that was when a decanting pipe was dropped, allowing slime to get into the filter.

SLIME TREATMENT AT KALGOORLIE

By M. W. VON BERNEWITZ

(December 14, 1907)

At the Associated Northern mine the ore is of a schistose nature, with quartz and calcite; the valuable ore carries tellurides and iron pyrite, there being very little free gold.

The treatment consists of breaking the ore with a No. 5 Gates crusher, grinding through a 27-mesh screen in three No. 5 Krupp ball-mills, roasting in six Merton furnaces, mixing with weak cyanide solution, grinding to slime, and amalgamating the coarse gold in eight Forwood-Down (improved Wheeler) 5-ft. pans, settling the slime in V-shaped boxes, agitation of pulp in five vats 22 by 6 ft., filter-press treatment in three Dehne presses, and disposal of residue by belt-conveyor.

The slime from the settlers is run into the agitators with a consistence of about 1 to 1, it taking between 7 and 8 hours to fill one vat holding, say, 36 tons of dry slime. The cyanide solution is made up to 0.07%, and the consumption averages 1 lb. per ton treated. Agitation is continued as long as possible, but after 16 hours the pulp may be taken for filter-press treatment. For filling

the press a Pearn pump having three plungers, 12 by 10 in., running at 20 rev. per min., is used. This is a powerful pump, and with good thick pulp it will fill a press in 10 minutes, lifting in this time about 10 tons of pulp, and charging against a final pressure of 60 lb. per sq. in. The time taken in filling may be divided as follows:

Pressure	Minutes
Up to 25 lb.	4
“ 50 “	3
“ 60 “	1
Finishing with safety-valve blowing off at 60 lb.....	2
	10

The following is the treatment in detail of the pan product. Average screen tests of this are as follows:

Mesh	Percentage
On 30.....	Nil
40.....	Nil
60.....	0.5
80.....	2.5
100.....	4.3
150.....	4.9
Through 150.....	87.5

The presses are of the well-known Dehne make with fifty 3-in. frames for the slime, the usual cloth-covered high and low-pressure plates for filtering and hand-screwing gear. They hold about 4.5 tons of dry slime each. After a press is filled, the slime is washed for 25 minutes with weak cyanide solution, and a water-wash of 5 minutes at 100-lb. pressure, during which time each ton of slime is washed by 2 tons of solution. The washing is done by a similar pump to that used in filling, only that it runs at 13 rev. per min. A mercury gauge is used on this pump. It sometimes happens that there is plenty of mill-water on hand, so the final water-wash is dispensed with, the press then getting 30 minutes with solution. The decrease in the assay-values of the solution during washing is:

Period	Assay
At start of wash	\$12.50
After 5 minutes	6.60
“ 10 “	1.50
“ 15 “	1.50
“ 20 “	1.00
“ 25 “	1.00
“ 30 “	0.80

After washing, the content of the press is dried for 10 minutes with air at 80-lb. pressure. The press is then opened ready for discharging. Two men empty 11 presses per shift of 8 hours, say 50 tons, onto a traveling horizontal belt-conveyor 18 in. wide, which feeds an elevator-belt inclined at 27°, in turn discharging onto a motor-driven swinging-boom distributor.

The rich gold solutions from the filter-press, after being clarified in a small press, pass through three zinc-boxes, and the gold (running about 890 fine) is recovered in the usual manner. Most of the solution, used in washing the presses, passes into the mill

again to be used in the pans, etc. An average of three months' costs of slime treatment are as follows:

	Cost per ton.
Agitation and cyaniding	\$0.34
Filter-pressing	0.41
Precipitation, etc.	0.12
Disposal of residues	0.04
Total	\$0.91

The time taken in the different press operations is as follows:

	Minutes
Filling press	10
Washing	30
Drying	10
Discharging	30
Screwing-up, etc.	10

The mill has a capacity of about 3,700 tons of raw ore per month (say 3,200 of roasted ore), and with another 1,300 tons (previously roasted) from the re-treatment of old residue; altogether some 4,500 tons pass through the three presses monthly.

Monthly returns average about:

Ore milled, tons	3,700
Re-treatment, tons	1,300
Total value recovered	\$70,500
Profit	\$48,500

THE ROASTING OF TELLURIDE ORES

By R. L. MACK and G. H. SCIBIRD*
With an introduction by T. T. READ

(December 14, 1907)

INTRODUCTION

Telluride gold ores, now widely known, were first discovered in 1872, near Nagyag, in the historic goldfield of Transylvania, by a Hungarian peasant. From the first specimens Klaproth, sixteen years later, separated a new element which he named tellurium. Similar ores were shortly afterward discovered near Offenbanya, also in Transylvania. Tellurides of various metals were discovered from time to time in different parts of the world, but the next discovery of importance from a mining standpoint was in 1871, when tellurides of gold and silver were found in Boulder county, Colorado. These were extensively exploited, and until the deposits at Cripple Creek in Teller county were uncovered in 1891, Boulder remained the chief locality for such ores in the United States. Soon afterward (in 1893) rich deposits of telluride gold ore were discovered at Kalgoorlie in Western Australia. Cripple Creek and Kalgoorlie¹ entirely overshadow all the other telluride districts and are among

*Submitted in partial fulfilment of the requirements for the degree of Bachelor of Science in Mining Engineering, under the Faculty of Engineering of Colorado College.

¹ 'The Telluride Ores of Cripple Creek and Kalgoorlie.' T. A. Rickard. *Trans. A. I. M. E.*, Vol. XXX, pp. 708-718.

the chief producers of gold, Cripple Creek furnishing \$15,500,000 of the \$88,000,000 of gold produced in the United States during 1905, while the production of Kalgoorlie was approximately one-quarter of the total production of \$86,000,000 credited to Australasia.

There are some twenty-six minerals that contain tellurium, but of these not all are recognized as well established species. Five are tellurides of gold and silver, namely, calaverite, $(\text{AuAg})\text{Te}_2$ (Au 40%); sylvanite, $(\text{AuAg})\text{Te}_2$ (Au 25%); krennerite, $(\text{AuAg})\text{Te}_2$ (Au 36%); petzite, $(\text{AuAg})_2\text{Te}$ (Au 26%); hessite, Ag_2Te (Ag 63%); and one, nagyagite, is a sulpho-telluride of lead and gold (Au 7.5%). Recently Lenher has questioned whether the tellurides of gold and silver in nature are true compounds, since they will precipitate gold from its chloride solution.² So many compounds (galena, for example) have the power to reduce gold from its solutions that this argument does not seem entirely convincing. But the wide variation in composition of sylvanite and calaverite, which have the same chemical formula, lends color to the hypothesis that these minerals are essentially alloys of gold, silver, and tellurium, which by some unknown factor in the deposition of the ores, have been formed in approximately atomic proportions.

The difficulties presented in the metallurgical treatment of telluride ores were early recognized and have remained a subject of study to the present. The essential features of the problem are easily grasped. The telluride ores are all extremely brittle as well as extremely valuable; for this reason any ore-dressing method is entirely out of the question, as the losses in slime would be prohibitive. Direct smelting alone is also out of the question, as the ores do not contain lead or copper to serve as collectors of the precious metals, and, in the case of the Cripple Creek product, they carry so much alumina that they can only be slagged by mixing with other ore. In the case of the high-grade ores, which can bear the freight and treatment charges, it is possible to recover the precious metals in the dry way, by mixing them with leady ores in suitable proportions. In this way, there has grown up the custom of screening the ore at the mines; the lump ore is washed, sorted, and sent to the chlorination or cyanide mills for treatment, the fine screening, which is much richer, ranging in value from forty to several hundred dollars per ton (due to the brittleness of the valuable mineral, and the tendency of the ore to break finer where it is most rich), is shipped to the smelters. Naturally the handling of large quantities of fine in the blast-furnace presents much difficulty and makes briquetting necessary. More recently it has been found by experiment that in the Huntington-Heberlein process for the desulphurization of lead ore, the Cripple Creek fine can be used instead of lime to keep the charge from fusing too easily, and with equal success. In this way a large percentage of fine is handled cheaply and conveniently.

But the cost of smelting makes some other method of treatment

² Lenher 'Naturally Occurring Telluride of Gold.' *Jour. Amer. Chem. Soc.* Vol. 24, p. 355.

necessary for the ores of lower grade. It would be unprofitable to attempt to rehearse all the processes that have been tried and abandoned. Naturally, amalgamation was early tried on the oxidized ore of the upper portion of the veins, for although the tellurides themselves are not wetted by mercury and, consequently, are not amalgamable, yet in the oxidized portion of the veins the mineral has generally lost its tellurium, leaving the gold in a spongy brownish form, known as 'mustard' gold. But this gold is not in a state suitable for amalgamation, partly because of its spongy nature, and partly because its surface is not clean and bright, allowing ready wetting by the mercury. Leibius decided that the 'rustiness' was due to a coating of iron oxide on the gold; and other writers have ascribed it to a coating of the tellurite of iron (a mineral described by Knight³ which has no mineralogical name, and is doubtful as a mineralogical species). It seems most probable that it is chiefly due to the physical state of the gold, as gold precipitated from solution in a spongy form is not readily wetted by mercury, a fact which Henry Louis has ascribed to the existence of gold in a dimorphous form.

Of the various wet methods, only two, chlorination and cyanidation, have met with any degree of success. Cyanidation was early tried on the oxidized ore, but because the process had not then reached as advanced a state of development as at present, the results were not usually successful. Many difficulties were encountered, of which probably the chief were the mechanical ones of leaching the finely ground ore and filtering the solutions. The unoxidized ore is not amenable to cyanidation, as the telluride is not readily attacked by cyanide solution. The treatment of the ores by chlorination involves a preliminary 'dead' or 'sweet' roast to eliminate all reducing substances, which would otherwise consume chlorine. The advantages and disadvantages of the chlorination process for Cripple Creek ore have been discussed at length by Greenawalt and Argall in a series of papers published in Vol. 78 of *The Engineering and Mining Journal*. Until recently the chlorination process has been regarded with more favor than the cyanide process. But since the chlorination process costs for extraction approximately \$3.50 per ton on average ores, and only gives a yield of 95% of the gold and none of the silver contained (which gives a tailing richer than \$1 per ton on average ores), there has naturally arisen a demand for a cheaper process which shall give a greater extraction. Temporarily the chlorination process is supplemented by concentrating the tailing from the chlorination barrels on Wilfley tables, the concentrate being shipped to the smelters, while the tailing from the tables is cyanided by decantation.

The application of the cyanide process to the unoxidized ores has been chiefly worked out by Australian metallurgists. Development has progressed along three principal lines, namely, (1) fine grinding, roasting in Merton or Edwards furnaces, and cyanidation

³ *Proc. Colo. Sci. Soc.* Vol. V, p. 66 (1894).

by leaching, decantation, filter-pressing, or combinations of these; (2) rather coarse grinding, roasting, amalgamation in pans or on plates, and cyaniding the tailing; (3) concentration on table to extract the sulphides (which are roasted and cyanided), followed by extraction of the gold from the unroasted tailing by means of cyanogen bromide. The difficulty in roasting and cyaniding direct is that the telluride mineral exists in the ore in rather coarse particles, which melt at the beginning of the roast into globules that afterward become, by the loss of their tellurium, pellets of gold, which are not entirely dissolved during any reasonable length of exposure to the action of the cyanide solution. The Western Australian ore also contains some free gold, which adds to this difficulty. This has been taken advantage of in the process of Sutherland and Mariner, who advocate crushing rather coarsely, conducting the roast in such a manner as to yield a maximum of the gold pellets, and then amalgamating these in pans and on plates. The chief objection to this method is the difficulty of preventing the escape of mercury into the tailing from the plates. The third method, known as the Sulman-Teed process, in which the gold is extracted directly from the unroasted ore by the use of cyanogen bromide, is entirely successful, but on Western Australian ores shows no advantage in cheapened cost or greater extraction. It seems highly probable, however, that if properly modified to meet the slightly different features of Cripple Creek ores, it could be applied to them at a less cost and with more satisfactory results than either of the other processes.

The roasting of telluride ores preparatory to cyanidation presents several unusual features. The roast is ordinarily controlled by determining the elimination of the sulphur. But the sulphur is essentially not concerned in the roasting, as the amount of sulphides present in these ores would not ordinarily affect their cyanidation, the real problem being to free the gold from tellurium in order that it may become soluble in the cyanide solution. Once begun, however, the combustion of the sulphur must be carried to completion to break up the sulphates at first formed. It is arbitrarily assumed that a roast which is satisfactory from the standpoint of the sulphur, has also satisfactorily eliminated the tellurium, but direct proof of this is entirely lacking. It is not even known whether the tellurium is driven out in the roasting of these ores. Richard Pearce⁴ has shown from experiments that the tellurium may be almost entirely changed to TeO_2 and retained in the ore, probably as a tellurite, but that the presence of pyrite causes it to be driven off to a much greater extent. He also found that tellurium may be sublimed directly in the roasting furnace, as crystals of it have been found to occur there. There remains, therefore, considerable doubt as to the behavior of the tellurium beyond that the gold is freed of it in a properly conducted roast.

In freeing the gold of tellurium, certain losses are known to

⁴ *Proc. Colo. Sci. Soc.* Vol. V, p. 144 (1895).

occur. These may be due to (1) a mechanical loss in dusting from the driving out of the moisture and gases of the ore, (2) a mechanical loss from the driving off of tellurium from the gold, (3) a loss by actual volatilization of the gold. F. C. Smith⁵ found an average loss of 11.45% of their gold content on roasting various samples of the Potsdam ores of the Black Hills for one hour. The method of conducting the roast is not described. It is well known that no such losses as these ordinarily occur in roasting Cripple Creek ores. It seemed wise, therefore, to undertake to investigate what the losses in roasting actually are, and how they are affected by various physical conditions.

EXPERIMENTS IN THE ROASTING OF TELLURIDE ORES

Methods of Procedure.—The object of this investigation was to find:

1. The effect of the size to which the ore is crushed before roasting, upon the degree of desulphurization attainable and upon the loss of gold.
2. The effect of the temperature at which the roast is conducted upon the desulphurization and loss of gold.
3. The amount of gold lost during roasting.
4. The relative distribution of the gold in the various sizes of crushed ore.

The ore upon which the tests were made was a lot of about 300 lb. obtained from the Portland mine, which is situated on Battle mountain, in the Cripple Creek district, Colorado. It is representative of the ore of that mine, as described on page 442 of Professional Paper No. 54, issued by the U. S. Geological Survey on the 'Geology and Gold Deposits of the Cripple Creek District.'

"All the unoxidized ores are alike in owing their value to the presence of a telluride of gold which seems to be almost invariably calaverite, although the occurrence of sylvanite has been reported by Rickard. This telluride is rarely found in well formed crystals and is frequently present in particles so minute as to be invisible to the naked eye. The ore most typical of this mine is that occurring in breccia, which is fine grained and gray, made up of barely recognizable fragments of phonolite and andesite and locally blocks of granite sometimes as much as from one to six feet in diameter. Finely disseminated through it are much finely divided pyrite and considerable scattered carbonate. The calaverite occurs in very narrow fissures or joints in this breccia, associated with crystalline films of dolomite, with sometimes a little silica and fluorite. In most cases the ore shows very little calaverite to the naked eye. The value of the ore appears to lie wholly within these narrow joints. The fine pyrite impregnating the breccia is not known to be auriferous."

The following table shows a comparison between analyses made by the U. S. Geological Survey on Portland ore and that made by us. The Survey analysis was made on "Normal ore from the Portland mine, largely from breccia, country rock, and slightly oxi-

⁵ *Trans. A. I. M. E.* Vol. XXXI, p. 1 (1896).

dized.”⁶ The object in making this analysis was to find out if any great variation existed between our lot of ore and that experimented on by the Survey :

	U. S. G. S.	C. C.
SiO ₂	54.91	54.68
Al ₂ O ₃	17.80	17.87
FeO	4.80	5.30
MgO	0.36	0.20
CaO	2.04	2.65
Alk	12.00	12.00
MnO ₂	0.66	0.94
S	2.49	2.25
		3.08

The ore upon which our tests were made was taken from a hopper just before going to the roasters at the Portland mill. It had been broken by Blake crushers, followed by rolls, and all had passed through a 14-mesh screen. The following table shows the results of a screening test and the percentage of gold in the various sizes. A comparison is also shown between the screens used for this test and those recommended by the Institution of Mining and Metallurgy. The dimensions of the wires and apertures of the screens were obtained by means of a microscope having a micrometer eye-piece, the results being the average of a large number of readings. The nest of screens used, of the meshes shown, were of the usual 8-in. heavy tin-plate, brass gauze, as obtained from the Denver Fire Clay Company :

Mesh.....	C. C. screens		Committee.		Wire, diam. Inch	Gold, Oz. per ton.....	Size of gold, %.	Ore retained on screen, %	Size, %
	Aperture, Inch.....	Diameter, Inch.....	Screen ap- erture, %	Aperture, Inch.....					
20	0.036	0.015	49.0	0.027	0.023	1.40	7.56	7.07	2.61
40	0.0162	0.0092	41.0	0.0132	0.0118	0.96	23.75	32.39	2.47
60	0.0096	0.0074	32.5	0.0082	0.0085	1.37	17.17	16.41	2.62
80	0.0075	0.0051	35.4	0.0065	0.006	1.55	8.72	8.01	} 3.04
100	0.0055	0.0047	29.6	0.0056	0.0044	1.22	4.54	4.87	
120	0.0043	0.0042	25.6	1.56	8.08	6.78	
150	0.0038	0.0029	31.7	0.9039	0.0028	1.57	4.05	3.38	
Through 150	1.58	25.38	21.03	3.93

The screening test was performed by placing 100 grams of the crushed ore upon the coarsest of the nested screens and replacing the cover. The nest of screens was then inclined at an angle of 30° and the ore made to pass across the screens by jarring them with a heavy spatula. When it had all been brought to the lower side, the screens were again tilted to bring this side uppermost, and the ore made to pass back again. This process was continued until it was judged that no more material was passing through. The top screen was then removed, the material retained on it weighed, and the jarring process continued some time longer on the next screen. In

⁶ 'Geology and Gold Deposits of the Cripple Creek District,' p. 172.

this way the finest screens received, as is necessary, more jarring, and the comparative uniformity of the results thus obtained indicate the accuracy of this method of performing the screening assay. Five trials are recorded:

WEIGHT RETAINED.

MESH.	1 %	2 %	3 %	4 %	5 %	Aver- age. %
On 20.....	7.2	7.27	6.9	6.6*	7.4	7.07
“ 40.....	30.87	32.18	32.4	31.8	34.2	32.39
“ 60.....	17.32	16.05	16.4	16.1	16.2	16.41
“ 80.....	7.12	8.53	8.2	8.4	7.8	8.01
“ 100.....	4.76	4.28	5.3	5.2	4.8	4.87
“ 120.....	6.49	5.92	8.1	7.1	6.3	6.78
“ 150.....	3.56	3.66	3.0	3.6	3.1	3.38
Through 150.....	22.41	22.17	19.1	21.7	19.8	21.03
Total.....	99.83	100.06	99.4	100.5	99.6	99.64

The amounts retained on the various screens were then sampled, crushed on a bucking board to pass 100 mesh, and assayed, the following charge being used:

One-half assay-ton of ore; 1 of lead flux; $\frac{1}{2}$ of Na_2CO_3 ; and 1 assay-ton of PbO . Then a borax cover.

The lead flux was composed of 16 parts, K_2CO_3 ; 16 of Na_2CO_3 ; 8 of flour; and 4 of borax.

Sulphur in each size was also determined, the following being used: Treat one gram of ore with $\frac{1}{2}$ gm. KClO_3 and 7 c.c. HNO_3 conc., adding 3 c.c. of the acid first and letting this boil to fumes of NO_2 and then adding 1 c.c. at a time, the final volume of the acid present being about 2 c.c. Then the flask was removed from the heat, diluted with 50 c.c. H_2O and an excess of Na_2CO_3 added to precipitate Fe, etc. The solution was then boiled 30 to 60 min., the bulk being kept constant. It was then filtered and the precipitate washed until it was free from all traces of H_2SO_4 . The filtrate thus obtained was acidified with HCl and boiled until all the CO_2 was expelled, when the SO_3 was precipitated with BaCl_2 and weighed as BaSO_4 after ignition. As is seen from the above table, a slight increase of gold is found in the fine. This is due to the fact that the gold minerals occur in the cleavage planes of the ore. When broken, it yields along the cleavage, since this affords lines of weakness, thus exposing the tellurides, which are scraped off and become concentrated in the fine. This difference is more marked between the lump ore and the fine screening than is the case with such fine ore as was used in the above tests, because this ore already consists of fine material and hence the opportunity for concentration is not so great. The increase of sulphur in the fine as shown by the above table is due to the fact that the pyrite disseminated in the ore being brittle is easily broken and worn away, and hence concentrates in the fine material.

Roasting.—The necessity for the roasting of tellurides preparatory to cyaniding is due to the insolubility of tellurides in cyanide solutions. Crooks says⁷: “Tellurium not only refuses to form a telluro-cyanide when fused with potassium cyanide, but takes the place of the cyanogen therein, forming potassium telluride, which is speedily decomposed by the action of the air, into potash and metallic tellurium.”

There is no action between the cyanogen radical and tellurium, but the alkali in presence of oxygen invariably dissolves some of the metal, forming a solution which has a reducing action. When a telluride ore is roasted it leaves a residue containing TeO_2 , and this oxide is very soluble in KOH , forming a tellurite, which also acts as a reducing agent and absorbs oxygen from the solution. The same change takes place with KCN with an evolution of HCN . Roasted tellurides are, however, capable of being treated, and the gold extracted with good results.⁸ It is said that when an ore has been roasted sufficiently to be ready for chlorination it is also in a suitable condition for cyaniding; the reverse, however, is not always true. The aim of roasting telluride ores before cyaniding is to leave the ore in such a condition that there shall be no deoxidizing agents or cyanicides present. The effect of cyanicides is simply to use up the cyanide in the solution, while the deoxidizing agents prevent the dissolution of the gold in a reasonable time. The objects of roasting are⁹: 1. To convert the base metals into insoluble compounds, or into compounds which, if soluble, do not act as reducing agents in the solution. 2. To form soluble compounds which do not decompose the KCN solution. 3. To liberate all the particles of gold and silver from any encasing matter. As it is not practicable to determine tellurium in the ordinary operations of the works, it is assumed that when the sulphur is well burned off the tellurium is also burned off, or volatilized. This assumed close relation between the actions of sulphur and tellurium does not seem to hold exactly for all ranges of temperature. The sulphur in telluride ores occurs almost entirely as FeS_2 (iron pyrite). The process of burning off the tellurium consists of three distinct changes, as follows:

1. $\text{FeS}_2 = \text{FeS} + \text{S}$. One atom of the S is rather loosely held and is driven off at a rather low temperature— 350°C (598°F).

2. $3\text{FeS} + 11\text{O} = \text{Fe}_2\text{O}_3\text{FeSO}_4 + 2\text{SO}_2$.¹⁰

The last reaction and the one most difficult to effect occurs at a temperature of about 695°C ($1,283^\circ \text{F}$) when the sulphate is decomposed as follows:

3. $2\text{FeSO}_4 = \text{Fe}_2\text{O}_3 + \text{SO}_3 + \text{SO}_2$.¹¹

If the temperature at the completion of the roast is not around 700°C ($1,290^\circ \text{F}$), FeSO_4 will be left in the ore, which dissolves cya-

⁷ ‘Select Methods in Chemical Analysis,’ p. 422.

⁸ Julian & Smart: ‘Cyaniding of Gold and Silver Ores,’ p. 114.

⁹ Julian & Smart: ‘Cyaniding of Gold and Silver Ores,’ p. 434.

¹⁰ Austin: ‘Metallurgy of the Common Metals,’ p. 62.

¹¹ Hofman: ‘Metallurgy of Lead.’

nide and robs the solution of its free oxygen. On the other hand, the temperature must be low at the start of the roast or some of the base metals and tellurides may fuse and form (with the iron pyrite) a matte, which encases the gold, destroys the effects of previous fine grinding, and prevents the solution from dissolving the gold in a reasonable length of time.

A telluride ore crushed to go through a 14-mesh screen and containing 3 to 4% sulphur, if heated to a temperature around 1,095° C or 2,000° F, will be highly fritted. This is shown by tests made by us, the temperatures being determined by the Fery pyrometer (Test No. 3). The same test also showed that the temperature best adapted for driving off sulphur is obtained by slowly heating the ore, with an excess of air, up to 830° C (1,526° F) and also that the sulphur may (in the case of Cripple Creek tellurides) be properly burned off at a temperature considerably below the fritting point of the ore.

If a high-grade coarsely crushed telluride is roasted, a condition may result known as shotting of the gold. It is due to the fact that the telluride melts at a comparatively low temperature and forms globules, which, on roasting, lose their tellurium, leaving the gold at the end of the roast in the form of shot, which are very slowly attacked by cyanide solutions. In order to determine the temperature at which shotting occurs, the following tests were made: A copper Constantan thermo-couple was connected to a galvanometer. The junction was arranged so as to lie flat on a piece of mica, under which a wire gauze served to distribute the heat evenly. Small pieces of calaverite, the most common telluride of the Cripple Creek district,¹² were placed beside the junction and a Bunsen burner used to heat the both. By noting when the tellurium melted down, as was easily detected by the eye, the temperature required to effect this was read directly on the galvanometer. A series of these readings showed conclusively that the temperature required to melt this particular telluride is about 365° C (689° F). If calaverite is further heated the tellurium is volatilized and burns with a green flame. By the use of practically the same apparatus as in the previous test, it was found that the point at which tellurium begins to be driven off is 550° to 575° C (1,031° to 1,057° F) and that the tellurium continues to be volatilized until the melting point of gold is reached (1,064° C or 1,947° F). It was found that the smaller the amount of tellurium with the gold, the higher the temperature required to drive it off. This is due to the fact that the last part of the tellurium is mechanically held in the globules of gold. However, as would be expected, the amount of tellurium left with the gold after the sulphur has been well eliminated, varies directly as the fineness of the crushing, being least with fine crushing.

The average cost of roasting average telluride ores is 89 cents per ton. Of this cost 40c. is fuel expense. At this time no prac-

¹²Professional Paper No. 54, U. S. Geol. Surv., p. 442.

licable method has been discovered for the treatment of telluride ores without a preliminary roasting.

Experimental Roasting.—The method used was as follows: In order to ascertain, if possible, the amount of gold lost by dusting and volatilization of the tellurium it was necessary to weigh out $\frac{1}{2}$ A. T. of each of the various sizes. Five samples of each size were weighed, placed in $3\frac{1}{2}$ -in. scorifiers, and arranged in the reverberatory furnace. Four of them were to be used for assays of gold and silver, the fifth for a sulphur determination. By first assaying the raw ore and then assaying the roasted samples, the difference in the results would give the loss by dusting and volatilization. The process worked very well on the fine sizes, but not at all on the sizes coarser than 60 mesh, due primarily to the impossibility of obtaining an accurate sample, and secondarily to the difficulty of fusing the coarse ore. The necessity for weighing our samples before roasting them was due to the concentration resulting from driving off 3 to 4% of volatile substances. Several methods were tried to assay the coarse samples, but were not satisfactory. The best method is to grind them, after roasting, on a clean bucking-board, using the fluxes to clean the board after each grinding; however, even with the greatest care the results are not very satisfactory.

The concentration due to the driving off of sulphur and tellurium is nearly counterbalanced by the oxidation of Fe to Fe_2O_3 , but there is an unknown amount of concentration, which must be taken into account. Three separate roasts were made in the manner previously described; assays were run for gold, silver, and sulphur, before and after roasting.

Temperature Determinations.—In our first tests we used a Chatelier pyrometer with a thermo-couple of one platinum wire and one wire composed of an alloy of platinum and 10% of rhodium. This couple was introduced into the reverberatory furnace at the flue end, as shown in the sketch. It was encased in $\frac{3}{4}$ -in. gas-pipe, plugged and capped on the inner end, which enclosed a fused silica tube. The silica tube, sealed at the inner end, contained in turn, a double-bored fire-clay tube, through which the wires of the couple were drawn. These precautions were necessary in order to prevent any possibility of the furnace gases coming in contact with the couple, as platinum has the property of absorbing reducing gases, which reduce the slight amounts of impurities present in the platinum and cause a change in the electro-motive force of the couple.

By the use of such a couple only average temperatures in the furnace could be obtained, as the couple did not readily enough respond to changes in temperature, and also, due to its position, temperatures in other parts of the furnace could not be read. As it was desirable to read the temperature of each scorifier in the furnace a Fery radiation pyrometer was secured, which made possible the reading of the temperature of each scorifier in the furnace at frequent intervals. Thus the best conditions for elimination of the sulphur, and consequently of the iron also, could be determined. The Fery pyrometer depends in its action upon the law of Stefan

and Boltzmann, which is that the heat radiated by any heated body is proportional to the fourth power of its absolute temperature. In order to make use of the facts underlying this law, a concave metallic mirror is used to focus the heat waves radiating from the heated body upon the junction of a copper Constantan couple. The electromotive force generated by the action of the heat on the dissimilar wires is recorded on a galvanometer, so calibrated as to read degrees as well as millivolts. The mirror and junction are housed in a metallic cylinder, so supported on a telescopic adjustable tripod as to have freedom of motion about a vertical axis. Focusing of the pyrometer is done by means of a thumb-screw, which causes the two halves of the inserted image to come into coincidence on either side of a horizontal cross-wire. The furnace used was of the reverberatory type, as shown in the accompanying sketch. (Fig. 9.)

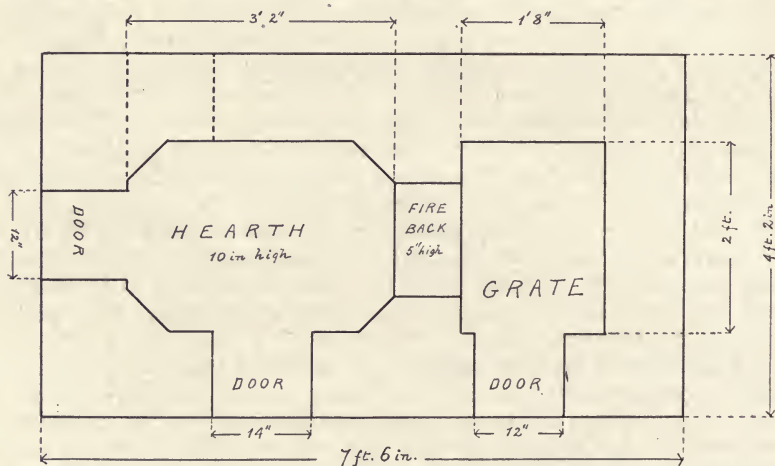

FIG. 9

Sketches are also appended to show the arrangement of the samples on the hearth during the roasts. (Fig. 10.) Also tables of temperature and curves to illustrate the variation of the temperatures.

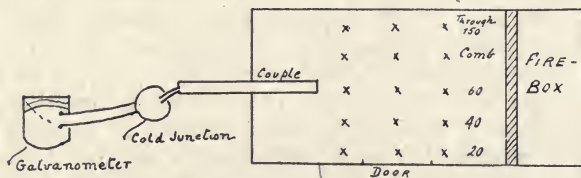

FIG. 10

Preliminary Roast.—A preliminary roast was first conducted as follows: A bed of ore about three inches deep was placed on the hearth, the furnace having been previously heated. As the temperature was raised, samples were taken at intervals of 20 min-

utes. The ore was well rabbled as the roast proceeded. The temperature was not sufficient to drive off all the sulphur, but the results obtained serve to show the rate of sulphur elimination. The original sulphur content was 3.08% and the final content was 1.02%. This shows that probably the temperature was only sufficient to drive off the first atom of sulphur, and the FeSO_4 formed was not dissociated:

Sample	Sulphur		Minutes
	Original	3.08%	
1	1.28		20
2	1.03		40
3	1.02		60
4	1.02		80
5	1.02		100
6	1.02		120

The above table shows the sulphur content and the rate of elimination. It shows that the greater part of the sulphur is driven off in the first part of the roast, and that to complete the sulphur elimination a much higher temperature is required. The curve appended (Fig. 11) shows this more readily.

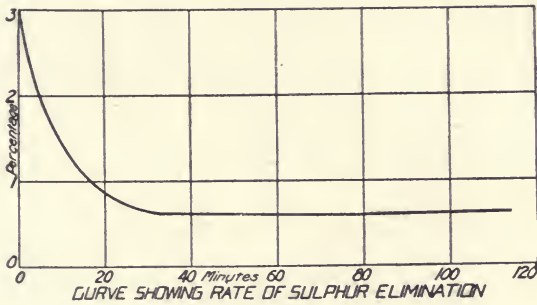

FIG. 11

Roast No. 1.—Three samples of each size were weighed and placed in 3½-in. scorifiers. The furnace was heated and the samples arranged on the hearth as shown in the following diagram (Fig. 12) :

There was such a small percentage of sizes 80, 100, 120, and 150 mesh that they were combined. The heat was steadily increased over a period of 2½ hours, the temperature as indicated by the couple was read at intervals of 15 min. during the roast. The following table and curve show the results of this roast. The temperatures are given in both Centigrade and Fahrenheit degrees:

ROAST NO. 1.			
MESH.	Sulphur percentage.		Eliminated, %
	Original.	Roasted.	
20.....	2.61	0.336	86.9
40.....	2.47	0.281	88.7
60.....	2.62	0.212	91.9
80 to 150.....	3.04	0.201	93.4
Through 150.....	3.93	0.116	96.9

This table shows that the fine contains a higher percentage of sulphur than the coarse; also that the sulphur elimination is best in the fine. The temperatures employed to effect the best sulphur elimination were, starting at 496° C (925° F), to raise slowly to 837° C (1,539° F). Time required was 1 hr. 45 min. for a small sample.

Time.....	Interval, minutes..	Deflection.	Gold Junction.	Temperature.		Remarks
			Degrees C.	Degrees C.	Degrees F.	
3:00	40.0	19	536	997	Started roast at 3 hr. 19 min. 7 sec.
3:16	16	36.3	496	925	
3:32	16	42.8	560	1,040	
3:46	14	45.1	585	1,085	
4:02	16	47.1	21	607	1,125	
4:16	14	63.0	766	1,411	Reached 804° C during this interval.
4:32	16	63.2	768	1,414	
4:45	13	65.7	792	1,458	
5:00	15	69.9	25	837	1,539	Allowed furnace to cool down.
5:15	15	69.0	826	1,519	
5:30	15	60.5	26.5	714	1,317	
5:47	17	41.5	550	1,022	

Roast No. 2.—This roast was conducted just as in the previous experiment, except that the arrangement of the various sizes in the

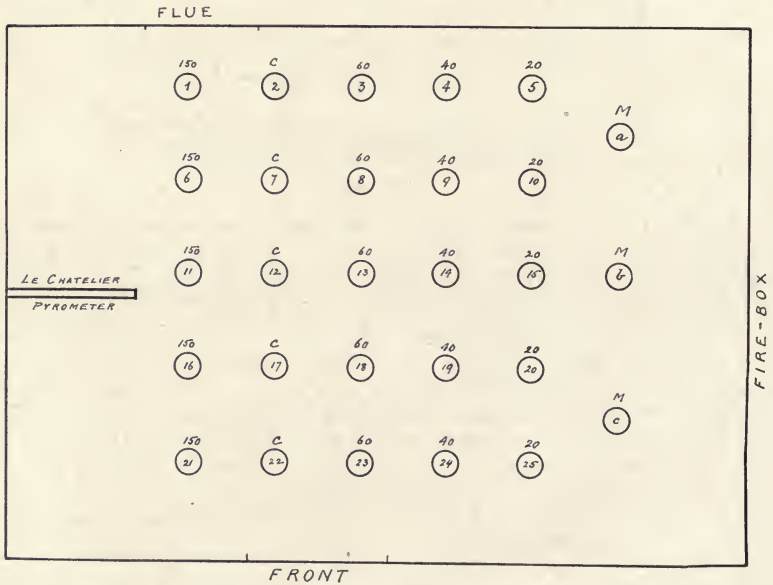

FIG. 12

furnace was different. In the first case the fine was in the hottest part of the furnace, while in this roast the coarse occupied the hot-

test place. As shown by the table, the temperature at starting was higher and the maximum temperature obtained was not so great. The range of temperature was 546° C (1,015° F) to 799° C (1,470° F). The best sulphur elimination was obtained on 20-mesh size, due to the fact that it was the hottest part of the furnace.

ROAST NO. 2.

Mesh.	Percentage of sulphur.			
	Original.	Roast.	Soluble.	Eliminated.
20	2.61	0.12	0.08	95.4
40	2.47	0.16	0.12	93.5
60	2.62	0.13	0.08	95.0
Comb.	3.04	0.48	0.33	84.2
150	3.94	0.99	1.71	74.8

Time.....	Interval, Minutes.....	Deflection, Millivolts.....	Cold junction Degrees C.....	Temperature.		Remarks.
				Degrees C.	Degrees F.	
2 : 40	41.4	19.5	546	1,015	Started roast. Reached 661° C during interval. Fired up. Reached 726° C during interval.
2 : 55	15	48.0	615	1,139	
3 : 10	15	51.0	21.0	647	1,197	
3 : 25	15	53.4	671	1,240	Reached 745° during interval.
3 : 40	15	54.1	26.0	680	1,256	
3 : 55	15	62.2	760	1,400	} Varied from 755° C to 794 during this interval.
4 : 10	15	65.0	27.0	789	1,452	
4 : 25	15	62.8	29.5	768	1,414	
4 : 40	15	64.5	31.0	786	1,447	
4 : 55	15	65.8	33.5	799	1,470	
5 : 10	15	64.9	35.0	792	1,456	Allowed to cool.

Roast No. 3.—In this experiment the temperature determinations were more complete than in either of the previous ones. Both the Fery and the thermo-couple were used to determine the temperature. The thermo-couple alone gives the temperature of only a part of the furnace, while by the use of the Fery, the temperature of the individual scorifier can be determined. Five samples of each size were placed in the furnace, in the positions shown in the accompanying sketch (Fig. 16); also three other scorifiers, in each of which was a quantity of the ore as it came from the rolls, being a fineness of about 14-mesh. These last three were to determine the point at which the ore frits. They were placed in the hottest part of the furnace near the fire-back.

The method of getting the temperature was as follows: The Fery was set up in front of the door, as shown in Fig. 12, and then the temperature as determined by the thermo-couple, which was inserted at the flue of the furnace was recorded, after which

the side door was opened and the temperature of the various scorifiers was read and recorded. At the end of the readings, the couple temperature was again recorded, thus showing the amount of cooling (due to the opening of the side door) during the reading. In this way the best temperature to give the best sulphur elimination could be ascertained; also the distribution of the heat over the furnace hearth could be noted.

ROAST NO. 3.

Mesh.	Sulphur percentage.				Gold assay.		
	Original.....	Roast.....	Soluble.....	Eliminated	Original.....	Roast.....	Loss in gold.....
20.....	2.61	0.18	0.11	93.1	1.40
40.....	2.47	0.10	0.08	95.9	0.96
60.....	2.62	0.12	0.095	95.4	1.37	1.34	0.03
Combined.....	3.04	0.12	0.095	92.9	1.49	1.46	0.03
Through 150.....	3.93	0.21	0.151	94.6	1.57	1.54	0.03

Time	Deflection, Millivolts.....	Cold Junction Degrees C.....	Temperature.				Remarks.
			Le Chatelier pyrometer		Fery pyrometer.		
			Degrees C.....	Degrees F.....	Degrees C.....	Degrees F.....	
3 : 20	6.50	16.5	783	1,439			Began charging.
3 : 30	5.70	17.0	705	1,301			Began to frit.
3 : 45	6.30		764	1,369	<i>a</i> 1,100	2,012	Had begun to frit.
4 : 00	5.90		728	1,336	<i>a</i> 1,005	1,841	
					<i>b</i> 995	1,823	
					<i>c</i> 990	1,814	
			766	1,411	<i>5</i> 895	1,643	Began to read 4:08.
					<i>10</i> 995	1,823	Le Ch. 800° C, 1,412° F.
					<i>15</i> 1,020	1,868	Began at <i>25</i> , read to <i>5</i> , then Le Ch. read 755° C, 1,391° F.
					<i>20</i> 990	1,814	
					<i>25</i> 1,020	1,868	
4 : 15	5.70	22.0	707	1,305	<i>24</i> 820	1,508	Le Ch. at finish 707° C, 1,306° F.
					<i>1</i> 840	1,544	
					<i>14</i> 915	1,679	
					<i>23</i> 880	1,616	
					<i>6</i> 850	1,562	
					<i>2</i> 865	1,589	
					<i>1</i> 840	1,544	
					<i>11</i> 850	1,562	
					<i>3</i> 890	1,634	
					<i>21</i> 770	1,418	
					<i>13</i> 905	1,661	
					<i>4</i> 900	1,652	

(Continued on Next Page)

4 : 30	6.52	24.0	788	1,451	<i>a</i> 1,095	2,003	Very much fritted.
					25 990	1,814	
					15 1,065	1,949	
					16 1,060	1,940	
					5 1,050	1,922	
					14 955	1,751	
					23 835	1,535	
					3 905	1,661	
					24 925	1,697	
					9 960	1,760	
					18 900	1,652	
					21 775	1,427	
					19 965	1,769	
					4 960	1,760	
					13 900	1,652	
4 : 35	5.70		707	1,306	1 815	1,499	Temp. at end of reading.
4 : 43	6.95		830	1,526			Opened doors.
4 : 45	6.80	26.0	817	1,504			
4 : 50	6.05		744	1,369			Fired up.
5 : 00	6.22		760	1,400	25 910	1,670	Row next to fire-box crusted over.
					20 990	1,814	
					15 960	1,760	
					10 960	1,760	
					5 950	1,742	
					24 810	1,490	
					19 825	1,517	
					14 830	1,526	
					9 830	1,526	
					4 840	1,544	
					23 740	1,364	
					3 790	1,454	
					2 730	1,346	
					1 710	1,310	
					21 700	1,292	
					22 700	1,292	
5 : 15	5.06	29.0	546	1,115			Temp. at end of reading.
	5.60		700	1,292			
5 : 30	5.60	30.0	701	1,294	25 780	1,436	
					20 865	1,589	
					15 865	1,589	
					5 870	1,598	
					4 845	1,553	
					3 825	1,517	
					2 810	1,490	
					1 780	1,436	
					21 720	1,328	
					22 710	1,310	
					23 710	1,310	
					24 730	1,346	
					18 780	1,436	
					8 785	1,445	
5 : 35	5.05		546	1,009	12 760	1,400	At finish opened doors and let furnace cool.
6 : 00	3.22	28.5	448	831			

The tables on p. 98 and the curve below show the results of roast No. 3:

The Loss by Dusting and Volatilization.—The assays of the various samples of roasted and unroasted ore were run under as nearly identical conditions as possible. Both scorification and crucible assays were used. The following table shows part of the results of these assays:

Mesh.	Original.	Roasted.	Loss.	%	Remarks.
Through 150...	Oz. 1.57	Oz. 1.54	Oz. 0.03	1.92	Mean of four. " " " " " "
Combined	1.49	1.46	0.03	2.01	
60.....	1.37	1.34	0.03	2.19	

This shows a mean loss of 2.04% of the original gold content. As the roasting was done in scorifiers and a very thin bed naturally

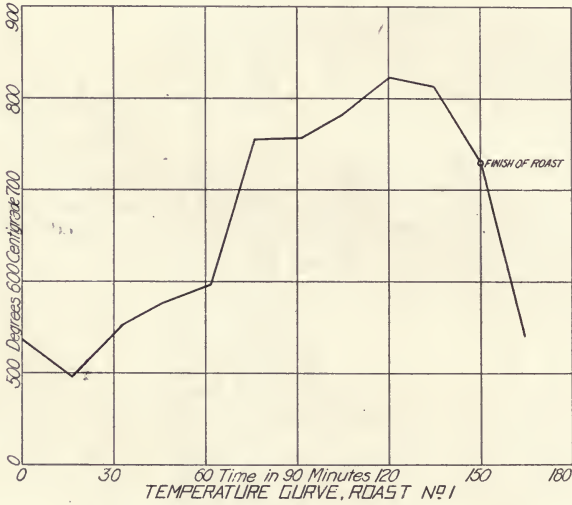

FIG. 13

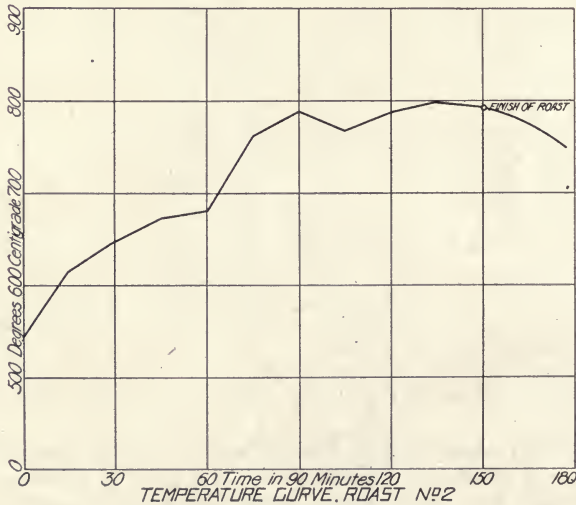

FIG. 14

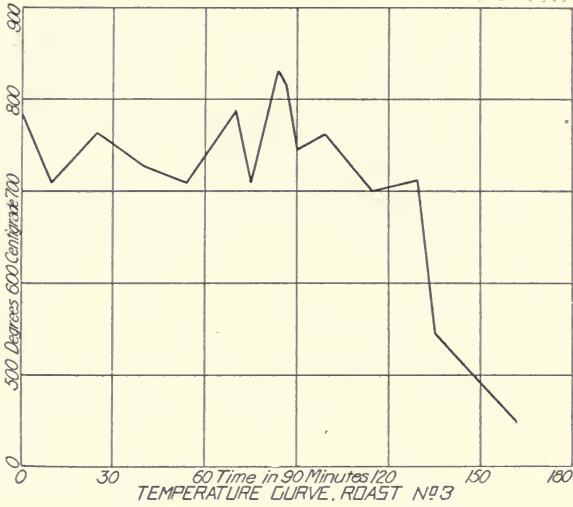

FIG. 15

resulted, no rabbling was necessary. Therefore, the loss due to dusting was only that caused by the escape of the volatile gases. The determination of the amount of loss due, respectively, to dusting and volatilization is a problem in itself. However, it seems likely, having regard to the temperatures at which these roasts were conducted, that most of the loss is due to dusting.*

The highest temperature used on these roasts was 1,065° C. The mixed sizes of ore in the three test scorifiers fritted at 1,095° C. It is claimed that there is no loss of gold due to volatilization below 1,100° C.† The distribution of temperatures in the furnace as given by the Fery pyrometer is shown below:

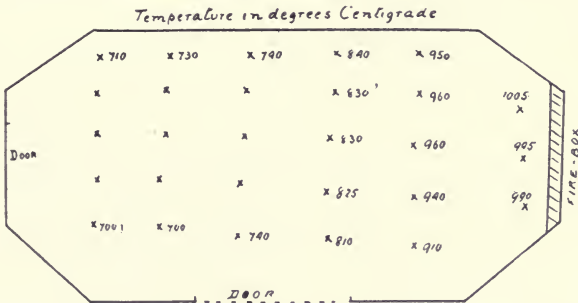

FIG. 16

As would be expected, the highest temperature is near the fire-box, the coldest part near the flue.

*Several custom mills allow 3% for loss due to dusting and volatilization.

†British Association. Report, 1897, p. 623.

Modern Practice in the Roasting of Telluride Ores.—By means of the Fery pyrometer we are enabled to read the temperature employed in one of the more prominent mills for the roasting of telluride ores. The furnaces were of the Pearce and Holthoff types. The Pearce furnace is an annular stationary hearth, with moving water-cooled rabbles, having four fire-boxes distributed around the outer circumference. Bituminous coal is used as fuel, the draught being increased by a jet of steam blown through the grate. The fire-boxes

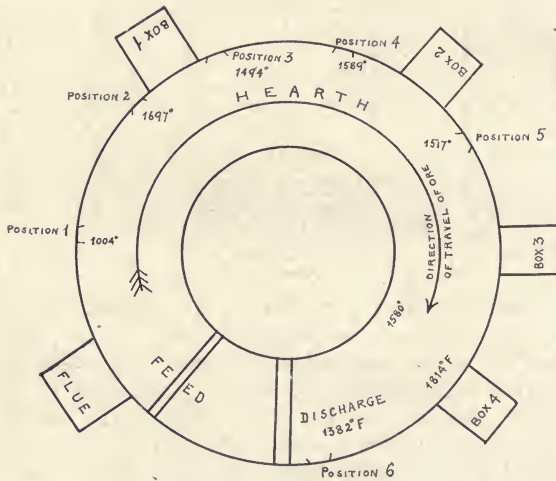

FIG. 17

are not placed at equal intervals around the furnace, but are arranged about as follows:

From flue to first firebox	is about	65 ft.
" box 1 to box 2	" "	40 "
" " 2 " 3	" "	30 "
" " 3 " 4	" "	20 "

The flame travels counter clockwise around the annular hearth, while the ore (which is fed in near the flue) travels clockwise, thus moving from the coolest to the hottest part of the furnace, the discharge being about 20 ft. beyond the last fire-box. Fig. 17 shows the various positions taken during the reading of the temperatures and the table below shows the result of the reading:

READINGS AT POSITION No. 1. 22 Ft. FROM FLUE TOWARD BOX 1.

	°C.	°F.	Remarks
1.....	560	1,040	Rabbles before firing.
2.....	660	1,220	" after "
3.....	540	1,004	Gases above ore.
4.....	540	1,004	" " "
5.....	530	986	" " "
6.....	540	1,004	" " "

POSITION No. 2. 2 Ft. FROM BOX 1 TOWARD FLUE.

	°C.	°F.	Remarks
1.....	855	1,571	Reading on ore 2 ft. from aperture.
2.....	925	1,697	Inner wall—across hearth.
3.....	925	1,697	Half-way across hearth.
4.....	835	1,535	1½ ft. from aperture—on ore.
5.....	855	1,571	2½ “ “ “ “ “

POSITION No. 3. 2 Ft. FROM BOX 1 TOWARD BOX 2.

	°C.	°F.	Remarks
1.....	780	1,436	On brick-work—across hearth.
2.....	822	1,512	Ore against back side of hearth.
3.....	812	1,494	“ on middle of hearth.

POSITION No. 4. HALF-WAY BETWEEN BOX 1 AND BOX 2.

	°C.	°F.	Remarks
1.....	850	1,589	On ore one-third across hearth from opening.

POSITION No. 5. BETWEEN BOX 3 AND BOX 4.

	°C.	°F.	Remarks
1.....	895	1,643	Across hearth on roof.
2.....	870	1,598	“ “ “ wall.
3.....	825	1,517	On ore 3 ft. from opening.
4.....	800	1,472	Rabble shoe.

POSITION No. 6. AT DISCHARGE.

	°C.	°F.	Remarks
1.....	860	1,580	Across hearth on wall-top.
2.....	855	1,571	“ “ “ bottom.
3.....	750	1,382	Ore at discharge.
4.....	990	1,814	Gas from box 4.

The second furnace from which temperatures were taken was a Holthoff. This differs from the Pearce in having a movable hearth with stationary rabbles, the gases being supplied from a producer in the centre of the furnace. The flame travels directly across the hearth in a radial direction to a series of small flues, which lead to the main flue. The ore, fed at the circumference, travels toward the inside of the hearth, where it is finally discharged to the cooling-hearth below. The chart, Fig. 18, shows the positions from which the readings were taken and the table below shows the results of the readings:

POSITION No. 1.

	°C.	°F.	Remarks
1.....	720	1,328	Ore on far side of hearth.
2.....	970	1,778	Gases from producer.
3.....	970	1,778	Ore below flame.
4.....	865	1,589	“ 2 ft. from opening.

POSITION No. 2. 30 Ft. FROM POSITION No. 1 TO RIGHT.

	°C.	°F.	Remarks
1.....	800	1,472	Brick across hearth.
2.....	990	1,814	Gases from port.
3.....	1,025	1,877	“ “ “
4.....	810	1,490	Ore across hearth.
5.....	690	1,274	“ 3 ft. from opening.
6.....	720	1,328	“ about middle.
7.....	745	1,373	Rabble far side of hearth.

POSITION No. 3. 18 Ft. FROM POSITION No. 1 TO LEFT.

	°C.	°F.	Remarks
1.....	780	1,436	Rabbles inside of hearth near wall.
2.....	900	1,652	Gas from producer.
3.....	1,010	1,850	" " "
4.....	830	1,526	Ore under port.
5.....	765	1,409	" in middle of hearth.
6.....	715	1,319	" 2½ ft. from opening.
7.....	500	932	" from discharge pipe.

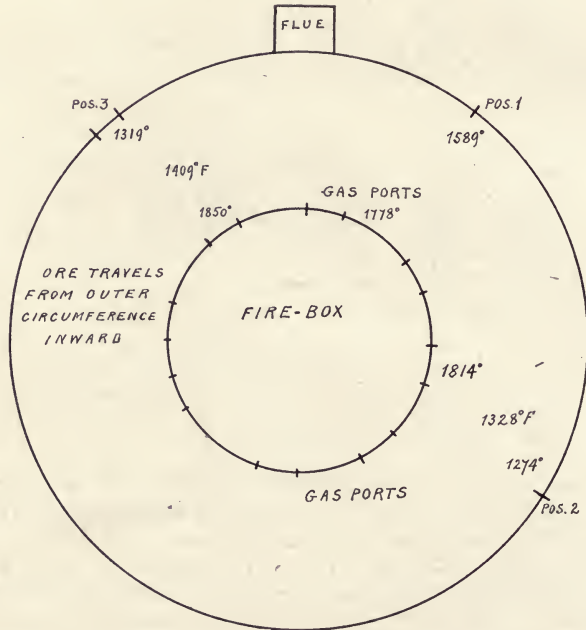

Fig. 18. CHART SHOWING POSITIONS OF READINGS ON THE HOLT-HOFF FURNACE.

Conclusions.—From the results of our tests on small samples of ore of various degrees of fineness, we are led to conclude that:

1. The degree of fineness, if it is under 14-mesh, does not appreciably affect the amount of desulphurization, the important factor being high temperature with a sufficient amount of air.

2. The actual loss of gold by dusting and (possibly) volatilization was the same for sizes through 150-mesh to 60-mesh inclusive, but the percentage loss was slightly greater for the coarse sizes.

3. The average percentage loss was 2.04%. This would probably not hold exactly in practice, because in the mills the flue-dust is recovered and re-treated.

4. Sulphur is eliminated equally as well by using a high first temperature as by using a low first temperature, but loss by dusting is increased.

5. The object in roasting is not the elimination of sulphur, but

of tellurium, the elimination of sulphur being an indication that tellurium is also eliminated. There is no practicable method for the determination of tellurium in works practice.

6. Calaverite melts at 365°C (689°F). If the telluride is present in large pieces due to coarse crushing of the ore, shottig of the gold results at temperatures from 550°C ($1,031^{\circ}\text{F}$) to $1,064^{\circ}\text{C}$ ($1,947^{\circ}\text{F}$), the latter being the melting point of gold. Advantage is taken of this fact in the process worked out by Sutherland and Marriner, in which the shot gold is caught on amalgamated plates.

7. That this telluride ore, which is representative of the Cripple Creek district, crushed to go through a 14-mesh screen will be fritted at a temperature of $1,095^{\circ}\text{C}$ ($2,000^{\circ}\text{F}$).

A CONICAL TUBE-MILL

(February 15, 1908)

The Editor:

Sir—Some twelve years ago I conducted my first experiment with the tube-mill, in the endeavor to crush a rich slag containing a quantity of matte for wet concentration, after 6 by 42. In high-speed rolls failed to do the work required. With the rolls the economic point was reached at 16 mesh. The tube-mill was brought to my attention as the Murphy 'barrel,' and I was prevailed upon to give it a trial as a last resort. The result astonished me; but it carried the work to the other extreme, and produced a slime which, as far as economic results were concerned, placed me in almost the same position as did the under-grinding by the rolls. While the work in this instance was costly, even though I made a gravity concentrate of about \$200 per ton, the experiment in the form of experience was worth the price paid. I realized the great capacity of the device, and also realized that it would not fill the requirements for ordinary concentration on account of its sliming. As cyanidation was then in an undeveloped stage, the experiment was charged to experience, and five or six years later it was utilized as a valuable asset. In the meantime, other engineers adapted the developed tube, or pebble-mill, to cyanidation, until today it is accepted as one of the necessary appliances for the recovery of millions of dollars per year, where margins of profit are sometimes limited to cents per ton, instead of dollars.

It is a question, whether even now the full possibilities of the device have been given the consideration which it deserves as a gradual reduction apparatus. The tube has been fed and choked with undersized material, but it has gone on 'doing business' in spite of abuse. Its great economic possibilities should have been the subject of more thought and experiment.

The pioneer in any line generally has to pay for his experience in cash or its equivalent, or as a sacrifice due to the criticism of his co-workers. In my own case it was with considerable temerity that I carried out the theory in a new device employing the tube-mill principle for crushing. The idea developed into laboratory

tests and the laboratory tests into a practical working machine, that is, my purpose was to clear the anvil cushioned with the remains of previous work, before placing upon it the next task under consideration, an idea often and ably expounded by practitioners such as Philip Argall, Ernest A. Hersam, and others of their class. While I do not claim to have achieved the acme of their requirements or of my hopes, still I feel that in developing and bringing out the conical pebble-mill, I have accomplished not only a first step, but a stride toward filling a long-felt want.

The first machine I devised on this principle was for the extraction of sapphires from a soft tufaceous rock. To crush the rock, meant crushing the sapphires. The satisfactory accomplishment of this end was finally realized by employing a mill comprised of two cones, using the coarse lumps of the sapphire rock as grinders; a method that I had previously used in the ball-mill, when grinding without the intervention of grinding-balls. The result was that the sapphires dropped from their matrix like plums from a plum pudding. Then the question arose, as to how to get them from the machine. This was contrived by inclining the mill at any angle from the horizontal while revolving, when any particle smaller than the grinding body immediately sought and took up a zone of vertical stratification according to its size rather than its gravity, issuing in a stream from the mill. The result was a mixture of sapphires, quartz, iron pyrite, and other materials, from an eighth to a half-inch in diameter. Here another difficulty in separation presented itself, which was finally overcome by employing gravity-jigs to separate the quartz and sapphires, and the Blake static-electric process for the removal of the sulphides.

To claim that sliming and coarse grinding can be accomplished in the same machine, appears to be unreasonable. That it can be done is illustrated by the case of the sapphires, and it is proved by the results accomplished by the conical mill adjusted for fine grinding, in competition with an ordinary tube-mill. The feed for the tube-mill was first crushed by stamps through 25 mesh, while the conical mill heading was the direct product of rolls, of which over 63% was the coarser than 20 mesh (from $\frac{1}{4}$ in. to 20 mesh):

	Mesh	On 40 %	On 60 %	On 80 %	On 100 %	Through 100 %
Conical mill, charge of 2000 lb. pebbles, consuming 15 hp.....	{ Head	75.7	6.6	5.5	2.3	9.5
	{ Tail	0.0	1.4	5.4	2.5	90.8
Regulation tube-mill, charge of 11,000 lb. pebbles, consuming 48 hp....	{ Head	1.5	13.5	17.0	17.5	53.0
	{ Tail	0.0	0.5	1.5	2.0	96.5

In this coarse crushing by a pebble-mill, it was realized that we had attained a point which was of far-reaching interest to the metallurgist, even though we had been working with what has been termed a 'freak' machine; but a freak only in so far that it does

something the other machine does not—for machines, like men, are freaks when they diverge from the trodden road of common usage.

In the most excellent article by Ernest A. Hersam, in the *Mining and Scientific Press* of November 16, commenting upon the loss of power due to friction or the interference of ore particles among each other, he says: "All such friction is lessened by a free discharge of the crushed ore as it becomes reduced to the size wanted. This condition is difficult to obtain. To crush the ore the masses must be retained between the approaching surfaces that administer the force. But while too great an amplitude in the motion of the pressure surface tends uselessly to compress the fragments, grinding these one upon another, and distributing the force in many directions—too little amplitude, on the other hand, fails

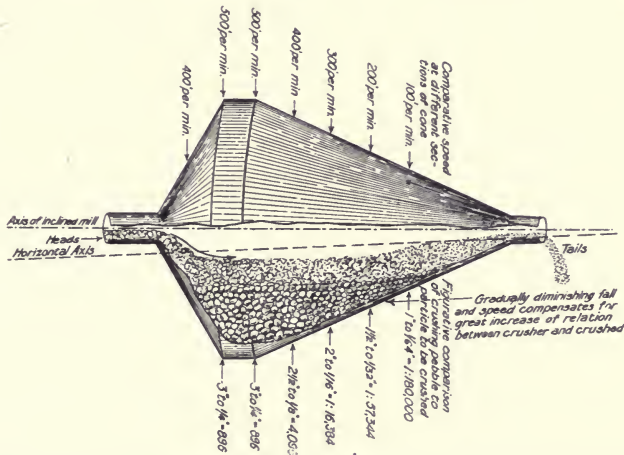

Fig. 19. DIAGRAM ILLUSTRATING GRINDING ACTION.

to do more than deform some of the particles, and failing to break these, it wastes whatever energy is so expended." These remarks not only apply to the crusher, stamp, or roll, but I believe more particularly fit the case of the ordinary tube or pebble-mill, whose consumption of power is so much greater than the work performed.

The tube-mill is ordinarily fed with material already ground to pass 20 mesh or finer; in which case fully 50% has already reached the maximum fineness desired, and therefore is a frictional interference to subsequent work. This work has been accomplished at a great expense of power: figuratively, it has been done and overdone; a sledgehammer has been employed to drive a tack. To illustrate: A 1000-lb. stamp, dropping upon a 1-lb. piece of ore with a 6-in. drop delivers a blow of 500 ft. lb., or a relation of 1 : 500. In the subsequent crushing of the particle of the 1-lb. piece, the ratio is raised enormously. In the case of a 1-lb. pebble rolling down a rough 2 or 3-ft. incline, it would be pure supposition to figure foot-pounds exerted; but assuming that it expends a relative amount

of force, less the friction, and acting upon a mass a quarter-inch in diameter, the relation by weight will be 1:1024. But you cannot get this force successfully applied in either case unless you remove the interference due to the previously crushed material. In the case of the conical mill, the crushing bodies employed (pebbles) are of different diameters, such as naturally results from the wearing of the pebbles in their action upon the material to be ground; normal sizes being replaced as required. The larger sizes seek and maintain a relative position at the base of the cone or cylindrical part of the mill, where they act upon the newly fed particles. These particles, after being crushed, immediately pass forward to the next succession of sizes of pebbles, which in their turn act upon the second reduction, and so on up the incline of the cone, where a gradual reduction of applied forces takes place through the smaller sizes of crushing mediums, and less impactive force, due to the decreased peripheral speed.

The crushing ability of the smaller pebble, is inverse to its size, and this shows the waste of power in employing unnecessarily large bodies for work performed in the regulation cylindrical tube-mill, where classification does not take place, but a large proportion of the power is consumed in friction between pebbles and material already as fine as desired.

If a practical demonstration is desired of the sizing action that takes place in the cone outlet of the conical mill, I suggest as a simple experiment, with material on hand in almost any laboratory, the placing together of two glass funnels (preferably ribbed inside) with base to base, holding same together with adhesive tape, first partly filling one of the funnels with almost any material like fine dry sand to coarse gravel; revolve this apparatus at a slight angle from the horizontal, and watch the result. Explain it, if you can.

H. W. HARDINGE.

New York, January 20.

TUBE-MILL LINING

(November 23, 1907)

The Editor:

Sir—Referring to your issue of October 12, page 466, an article on 'Lining for Tube-Mill.' Had not a rather lengthy article been brought to my notice in the issue of another technical journal just received, I would not have felt justified in commenting at present upon the device mentioned in that article, in which is given results of the excellent work done through the use of the lining. Inasmuch as I have known the fairness with which you have always handled such matters, I beg to suggest that you will again give credit to him to whom credit is due.

While I may be wrong in my supposition, still I have seen fit to enter my protest against the use of this device, or at least the assumption of the credit which might possibly be due to others.

That I am justified in claiming this device to be my own, I beg to refer you to Mexican patent No. 6354, issued to me under date of February 22, 1907, which patent recites my claim to what I designate as the Hardinge conical pebble mill now undergoing practical experiments for definite and positive efficiency.

One of the claims of this patent covering the device for a self-forming tube-mill lining reads as follows:

“Un aparato para triturar materiales frágiles que comprende un barril ó tambor, uno ó ambos de cuyos extremos son conicos, estando un extremo provisto de una entrada y el otro de una salida, y estando la superficie interior del barril provista de proyecciones longitudinales entre las cuales se alojan los trozos ó piezas del material que se está triturando ó los cuerpos trituradores que se emplean para ayudar á afectar la trituración, ó ambos, los cuales constituyen un forro que protege el interior del tambor ó barril y que se renueva constantemente por sí sólo tal como en substancia se ha expuesto.”

Which being interpreted reads:

An apparatus for disintegrating friable material, comprising a tumbling barrel or drum having one or both ends conical, one end having an outlet, and the other end an inlet, the inner surface of the barrel being provided with longitudinal ribs or flanges between which lumps or the pieces of material undergoing disintegration become lodged, or crushing bodies employed to assist in the disintegration, or both, forming a lining which protects the interior of the barrel or drum, and constantly renews itself as set forth.

If I am claiming more than is my due, our El Oro friends must show that this device was in use previous to my original application for the patent on the same, made about a year since.

The original idea of this device occurred to me through the finding of pebbles of all sizes lodged firmly within any open recess of the tube-mill; more particularly, I found pebbles so firmly imbedded within the splayed edges of the silex bricks, that it was impossible to remove them without considerable force being applied, which observation I utilized as above stated.

Mexico is the first to publish my patent; I have purposely withheld publicity as much as possible until I was ready to make a positive statement; for, as you are aware, the mining or metallurgical engineer must deal with facts as he knows them, and not state suppositions as facts, when based on laboratory experiments alone.

H. W. HARDINGE.

New York, November 1.

(December 21, 1907)

The Editor:

Sir—In your issue of November 23 H. W. Hardinge claims credit for the so-called El Oro liners.

In fairness to him and to all concerned, I can state that the El

Oro liner was in use at the El Oro mill at least 18 months before his patent was granted. Lately I have seen mention of the El Oro liners, giving credit for the invention to the Dos Estrellas mill. As I was responsible for their introduction at the Dos Estrellas, I take pleasure in correcting this error.

The rib-liner mentioned was invented by J. R. Brown while in the employ of the El Oro Mining & Railway Co., and was later slightly modified by E. Burt, the present cyanide superintendent of the same company. This liner has been in use at the El Oro mills for over two years, to my certain knowledge; and about 18 or 20 months since, I had it copied and put into the tube-mill at the Dos Estrellas plant. Other parties in El Oro secured the Mexican patent rights for Mr. Brown's liner, and I believe that still another patent for a ribbed liner has been granted by the Mexican Government.

I enclose a photograph of the interior of the tube-mill showing the El Oro liner, taken in January or February of the present year. The fairy story going around that the invention was purely accidental, is, I believe, wholly unfounded. The ribbed liners were made with the idea in view of being able to use the pebbles as liners without the use of cement, and not to give the pebble a longer drop.

C. E. RHODES.

Guanajuato, November 29.

The Editor:

Sir—Referring to your issue of November 23, and to an article by H. W. Hardinge, we beg to say that a reference to the U. S. Patent Office files will show that on June 13, 1906, Joseph Rodney Brown, of Los Angeles (formerly of El Oro, Mexico), applied for a patent on "lining for grinding mills." The patent was allowed and issued on August 27, 1907, and bears number 864,357.

Three claims were allowed, namely:

1. A lining plate for a tube-mill and recesses therein for holding grinding bodies, said recesses being somewhat wider at the portion adjacent to the axis of said mill than at the portion remote from the axis, and adapted to retain material wedged therein.

2. A lining for a tube-mill comprising a series of ribs formed upon the interior surface of said mill, said ribs being narrower at the portion adjacent to the axis of said mill than at the portion remote from said axis, and grinding bodies held frictionally in the recesses between said ribs.

3. A mill of the character described comprising a drum adapted to contain material to be pulverized and a grinding or abrading material, said drum being provided with a lining having recesses adapted to retain the grinding material wedged therein.

As Mr. Brown's U. S. application was dated June 13, 1906, and Mr. Hardinge's Mexican patent was issued January 22, 1907, and further, as it requires two to three months time in which to secure

a Mexican patent, it would seem that Mr. Brown was the prior inventor of the El Oro tube-mill lining.

BLAISDELL COMPANY.

Los Angeles, December 6.

TUBE-MILL LINING, SLIME-FILTERS, AND PATENTS

(February 1, 1908)

The Editor:

Sir—About three years ago, I used an old boiler, 40-in. diameter, to make a tube-mill for working cemented gravel, by putting six 4-in. angle-irons lengthwise inside, with the idea that the stones would jam between the angles and form a lining which would prevent wear on the boiler-shell. I made heads for each end, and the necessary trunnions, gear, etc., for running it with a horse-whim. Unfortunately, the high-grade gravel gave out by the time I had finished the mill, and it lies in the scrap-head behind the shop.

During the winter of 1906, when considering the question of re-lining our tube-mill, I designed a lining, to be made in our local foundry, of hard iron (from worn out shoes and dies). This lining was designed in four segments, 4 in. wide, forming a circular arch fitting tight around the inside of the shell, with 16 partitions raised 3 in. and set lengthwise of the shell. These partitions were thickest at the inner end, so that the spaces between them were in the form of a dove-tail; the idea being that the pebbles would jam in these dove-tail spaces and form a pebble lining.

Some time in the spring we had a very pleasant call from Charles E. Rhodes, general manager of the Waihi mine in New Zealand. We spoke of tube-mills and I made a rough sketch of my idea of this iron lining, and mentioned the fear I had of its working loose unless bolted in. He told me it would stay in without bolts, as their superintendent, Mr. Barry, had invented the same thing and was using it, only instead of waiting for the pebbles to fill the spaces he filled them with flinty quartz from the mine, held in cement.

On July 28, 1907, there appeared in the *Mining and Scientific Press*, a description and drawing, together with an abstract, of Mr. Barry's patent tube-mill lining. It is called 'honeycomb' evidently because the spaces in the castings are similar to the cells of the honeycomb. There is no date given for the patent, nor does it state the country from which it was issued. At the April meeting of the American Institute of Mining Engineers a paper was presented by E. G. Banks describing this same honeycomb lining.

On October 12, 1907, there appeared in the *Mining and Scientific Press* a description, with drawing and photograph, of a cast-iron lining for tube-mills in use at the El Oro mine in Mexico. In many ways it is similar to Barry's.

On November 23, 1907, in the same journal, under the head of 'Tube-Mill Lining,' an article was published describing a similar lin-

ing, with quotations from a Mexican patent of February 22, 1907, granted to H. W. Hardinge.

On December 21, 1907, there appeared a letter from C. E. Rhodes referring to that of November 23, giving a photograph of the interior of the El Oro tube-mill and stating that "said liner has been in use in the El Oro mills for over two years."

On the same page is a letter from the Blaisdell Company, stating that reference to the U. S. Patent Office files will show that on June 13, 1906, Joseph Rodney Brown of Los Angeles (formerly of El Oro) applied for a patent on lining for grinding-mills, which was issued on August 27, 1907. Quotations of specifications from Brown's patent are given which would apply equally well to Barry's.

In May, 1907, Edwin Letts Oliver, who has charge of the cyanide work at the North Star mines, Grass Valley, constructed a small working model of a continuous slime-filter, which may be described as a revolving drum about two-thirds submerged in thickened slime. On the circumference was the ordinary filtering material and through the trunnions an arrangement to produce a partial vacuum or a pressure of air. On the outside of the filter a knife was fixed to scrape off the filtered material. This model did so well that work was immediately started for the construction of four drums 6 ft. wide and 6 ft. in diameter. Soon after the drawings were made, and the orders out for their construction, we had a visit from Jas. W. Neill, of Salt Lake, who was much interested in slime-filters. On seeing a sketch of our scheme he remarked that it would work all right, but we could not get a patent on it; the manufacturing chemists had been using exactly the same thing for fifteen or twenty years. As we cared nothing about the patent, it was enough for us to have the assurance that the machine would work.

Within a few weeks, on November 9, 1907, a letter was published in the *Mining and Scientific Press* from Askin M. Nicholas of Australia, accompanied by a drawing, stating that a U. S. patent had been granted him in February, 1899, for a slime-filter. The drawing showed a machine strikingly like the one we were constructing, and a month later, on December 7, the same paper published the patent specifications. Except in detail of construction, these patent specifications would equally well apply to our machine.

On August 24, 1907, there appeared on the front cover of *The Engineering and Mining Journal*, a large advertisement as a "Slime Announcement. Users and prospective users of **submerged suction** or **vacuum** or **submerged pressure filters**, are hereby informed and **warned** [black type copied] that the last three years litigation involving the well known Moore Filter Patents for treating slimes has come to an end, with the result that all rights, titles, interests and claims to these fundamental patents now rest in this corporation, of which Mr. George Moore (the inventor) is general manager. While this litigation has been pending, numerous installations under many different patent claims and titles (all clearly evident infringements) have been made and are in successful operation all over the world.—The policy of this (new) corporation is to promptly sup-

press all infringements. For full particulars address the Moore Filter Company."

On the inside of the cover of the *Mining and Scientific Press* of January 11, 1908, is an advertisement of 'The Filtration of Slimes by the Butters Method.' Among other things it states, "We are working under valid American and Foreign Patents and shall protect our customers. The Butters Vacuum Filter Company."

The Kelly Patent Filter Press has been advertised for several months, and there is also the Burt and the Rapid. Grothe's great pressure-filter in Mexico—a splendid adaptation to conditions—I believe is not patented. In the patent announcements of your January 11 number, however, is a revolving filter which might be intended as a copy of Mr. Nicholas', showing that the patent industry is still thriving.

In the matter of the tube-mill lining, it seems to me that Mr. Barry should have the honor of being the first to make an iron lining holding the pebbles for pebbles to grind on, though Mr. Brown, Mr. Hardinge, and even I, may claim that our ideas were equally original, but they came later.

As to the filter, there can be no doubt that Mr. Nicholas was the first to use the submerged filter, with air to blow off the cake, for stamp-mill slime, but there were the manufacturing chemists using the same method for getting their soda ten years before. Mr. Moore, Mr. Butters, Mr. Kelly, and Mr. Oliver are undoubtedly entitled to originality of ideas, but they came later than Mr. Nicholas' and most of them had original ideas in the details of the methods used and not as to the broad use of the process.

"Render unto Caesar the things which be Caesar's." Without brag or threats, the priority in these matters seems to rest with our modest friends, the alert engineers of Australia and New Zealand.

But amid the mass of patents and claims, the forgotten man is the mine manager, who, after all, is the man who makes success or failure for the patentees. He is in desperate trouble because his tailing is running down the gulch carrying gold, perhaps enough to make all the difference between profit and loss, and yet, when he reads the various patents—or the advertisements—he hesitates about putting in a slime-plant, lest the patent lawsuits worry him more than the loss in the tailing. Possibly it would be better business for the patentees and manufacturers to offer a few words of encouragement to the miner, and, instead of threats of suppression and dire calamities, use soft words to induce him to adopt their special machinery or process because it is better or cheaper than others. For it may occur to this miner, that tube-mills and vacuum-filters and pressure-filters were in use long before the present generation of inventors was born, and whereas patents may issue without thought and without number, he may conclude that "a dream cometh through the multitude of business, and a fool's voice is known by the multitude of words."

ARTHUR DE WINT FOOTE.

Grass Valley, California, January 17.

PROGRESS IN THE TREATMENT OF GOLD ORE

By ALFRED JAMES

(January 4, 1908)

It will not be possible for me to review the progress of gold ore treatment for this year in as detailed a manner as is usual, owing to these notes being written while traveling some thousands of miles away from my base.

Fine sliming and the treatment of slime is again the most interesting feature of the year's progress; even former exponents of coarse crushing are now converts to modern slime practice. From eastern Asia to Western Australia and from South Africa to North America sliming methods are pre-eminent and have modified the other processes employed in the industry, such as crushing to tube-mills and the roasting of ores previously ground very finely.

Less has been heard this year of pans. Experiments in the Transvaal appear to have resulted in favor of tube-mills, and many more of them have been installed. With heavy stamps the Luipaards Vlei appears to have been able to crush 8.5 tons per head per diem, but in Rhodesia I am advised that 10 tons per head is being obtained in more than one instance—crushing, however, to pans instead of tube-mills.

The Rhodesian practice differs from that of the Rand. With their much smaller installations, pans are found to be more suitable and efficient, as being cheaper to install, forming more convenient units, and making less demand on power. In consequence, there are but few tube-mills operating in Rhodesia. The pans thus used are of the Western Australian type.

But tube-mills have unquestionably been much improved. Linings now last longer and instead of having to stop a mill every three weeks or so for a week for a new lining, it is now possible to run for three to six months with a lining placed in position in from two to three days. Automatic linings such as those of the El Oro, where pebbles are supposed to fix themselves in recesses cast in iron liners, do not yet appear to have proved themselves entirely satisfactory, and changes have recently been made in the shape of the recesses, which have now their sides chamfered to each other. The use of quartz or other lode-matter to be crushed in place of imported pebbles has much increased, and this with the utilization of quartz and local chert or other hard rock in linings of the Barry or Brown type has materially reduced the cost of operating tube-mills. In Africa a mill is started with a charge of pebbles containing say up to 10% lode-matter, then in regular work it is found possible to reduce the daily feed of pebbles by 5%, adding rough lode stuff to balance until the daily feed contains only 10% of pebbles, the whole of the balance being the product of the mine.

It is in the treatment of the slime produced by tube-mills and other grinders that the progress of the year has been most manifest. The decantation process, which originated in Africa and which has so long survived there, has now had its day. Designed to treat material

of low value at that time not amenable to any other method, it has resulted in profits being realized from material that otherwise must have run to waste. But the huge and expensive plant and low extractions must now give place to more automatic methods involving cheaper equipment and higher saving, and already such cyanide experts as J. R. Williams, W. A. Caldecott, E. J. May, and H. S. Denny have been looking into processes employed elsewhere, notably the Butters, Burt, Ridgway, and Merrill filtering devices.

In these notes of last year reference was made to the new Denny plants at the Meyer & Charlton and the New Goch. The Denny brothers severed their connection with these two mines shortly afterward, but in spite of their absence filter-pressing appears to be regarded as successful by the management, although much doubt has been expressed as to the wisdom of running cyanide solution through the mortar boxes. George Albu has criticised this as making it difficult to obtain the assay-value of the mortar-box product, but I assume this point would not be regarded as serious if Mr. Albu were convinced he was obtaining a higher recovery of his gold. On the Rand, however, the Denny methods have not been followed. Rhodesia, on the contrary, having investigated the results, has had quite a small Dehne filter-press boom, plant after plant having been installed during the last year.

But undoubtedly filter-pressing, even with Dehne presses, must give way before the suction filters, of which so much has been heard in the past year. Cheap and efficient, the daily tonnage handled by vacuum-filters is increasing by leaps and bounds.

Of the various vacuum-filters on the market I most unhesitatingly refer first to the Ridgway. This differs from the filters of the basket type in being more rapid, working with thinner cakes, giving better washing, and emptying itself in more cleanly fashion (automatically) than the basket-filters. Working as it does with the whole cycle of operation complete in 60 seconds on normal slime, it will be seen that difficulties, such as keeping material on cloths during transit of frames or during emptying and filling of vats, are entirely avoided, while the washing of so thin a layer as $\frac{1}{4}$ to $\frac{3}{8}$ -in. thick is much more rapid and complete than the washing of a cake of double or treble the thickness. The Ridgway is thus able to work with a much smaller area of filter-cloth for any given capacity.

During the year a 500-ton plant has been put into successful operation at the Great Boulder in Western Australia, and I understand another plant of similar capacity has already been started. Plants of similar and smaller capacities have been erected (or are in course of erection) in Mexico, India, South Africa, and eastern Asia. The official figures of the West Australian Chamber of Mines shows Ridgway to be working under expensive local conditions (such as purchased power, dear labor and supplies) for under 8 cents per ton treated; in Africa the costs should be little more than half this.

The Butters-Cassel filters have been installed widely in Mexico as well as in the Western States of America, not perhaps because

it was the best vacuum-filter—the recent published correspondence shows the pioneer Moore to be at least the equal, and probably the superior—but because it was pushed by a man of repute and of great energy who was recommending the best thing he could get hold of. But in the recent correspondence in the technical papers it appeared to me that only the parties writing in favor of the Butters-Cassel filter were those who were, or had formerly been, associated with Butters, while the Moore was recommended time and again by parties in no way associated with Moore, who had laid it down after investigation and who were apparently in no way connected—not even by paying royalties—to Moore or his associates. Certainly if Moore process had been run with half the energy, experience, knowledge, and skill of the Butters, I cannot imagine the latter type of filter to be employed at all.

For it is obvious that the hoisting of a basket of frames is a much neater and better and quicker expedient than the pumping in and out of pulp and solution or wash, each successive charge being mixed with the residue of the previous charge, whether of pulp or solution or water, and it is within the knowledge of men experienced in slime filtration that the maintenance of a vacuum in a basket half immersed—or partly immersed for say four periods of ten minutes each during each cycle of operations—does not make for good results. The lower portion of the cake is being thickened by pulp deposit while the upper is cracking from the inrush of air, an unequal cake is formed, and the washing must be unequal, and there seems to be a great waste of water in discharging the cake after filtration. From the published correspondence it seems to be laid down without serious contradiction that the Moore is more accessible and open to inspection, and that it does more work for a plant of given cost or in a given time.

Further modifications of the basket-filter have appeared in the form of enclosed filters worked by pressure or vacuum, such as the Blaisdell, Burt, and Kelly. This form of filter is scarcely new, and when tried some years ago proved itself unhandy, liable to freeze or choke, difficult to wash thoroughly, and difficult to discharge—in a word, it seems to be an attempt to work in the dark. Of course, modifications of the standard immovable enclosed type are made; one runs the frame into a cylinder or runs the cylinder away from the frame; this makes the operation more accessible but so far does not appear to be as successful as the pioneer basket type.

Reverting, however, to filter-presses, Merrill has at last got his big plant at work after three years' labor. It appears now to be working to nearly its full capacity—according to my recent information—and to be treating slime at a remarkably low cost. Advantage has been taken of every natural condition to make a successful working plant, and using static pressure to fill the presses and wash their charges, the Homestake costs are probably as low as any slime-treatment method yet put into practice. But my information is that with such a method the satisfactory treatment and hydraulic discharge of thick cakes in huge filter-presses is only possible with

crystalline or granular slime and with a great waste of water. In a word, it appears that successful results may not be anticipated by the process on ordinary slime under ordinary economic conditions; the thorough washing of 4-in. cakes is feasible only with crystalline-granular or readily permeable slime.

The successful handling of slime has also directed attention to the solution of the gold contained therein. Last year I referred to the system of treatment based on feeding solution or wash-water at the bottom of a vat, the slime contents of which were in a state of gentle agitation, the idea being an overflow of clear solution containing the gold content of the charge. W. L. Holmes, of Mexico City (formerly in South Africa), brought this to my notice some years ago, but it did not appear to make headway. Bewick, Moreing & Co. were working it last year in Western Australia, but evidently without commercial success, and this year Adair & Usher have been booming an apparently similar process in South Africa. Possibly some metallurgist at the Geldenhuis Deep, or elsewhere, may make something tangible out of the idea, but it looks as though the only result would be to call attention to the additional extraction obtained by the increased agitation of the pulp, and in this connection I have had reason to investigate the work of the Brown agitator.

This apparatus, introduced into New Zealand at the Komata Reefs, depends on the principle of the lessened specific gravity of a centre column into which air has been introduced at just such a pressure as will overcome the weight of the column of water at the point of introduction. There is no question of a jet of air-circulating solution on the principle of the injector, but merely the physical lightening of the weight of a column by the displacement of a small proportion of the water by air.

Brown uses long, narrow, vertical (cylindrical) vats, say 40 by 10 ft., or 55 by 15 ft., with a centre column of 1 in. diam. per 1 ft. of vat diameter. Into this central tube or column the air is introduced, and agitation is so effective as to lift stones at a minimum horse-power per ton. The power taken appears to be about $2\frac{1}{2}$ hp. per 50 tons of charge, which is the slime content of a 40 by 10-ft. vat. By this method the advantage of the accelerating action of air is obtained at a small cost.

The use of these vats has been offered to the Waihi—the manager of which speaks very highly of them—and Waihi Grand Junction in New Zealand, and a number have been installed in Mexico under the name of the 'Pachuca Agitator.'*

The progress of cyanide treatment for the silver-gold ores of Mexico has been one of the features of 1907. Chihuahua has been adopting cyanide with avidity, and Pachuca appears to be now coming into line. Of course, El Oro has done pioneer work, and Guanajuato has also been in the forefront. In almost every case the practice is similar; tube-mill sliming and treatment of the slime at first by decantation, but now by filter. High extractions

*See *Mining and Scientific Press* of November 30, 1907.

are claimed, but having regard to the natural refractoriness of silver sulphide ores—in some instances, as at Chinacates, associated with pyrite, chalcopyrite, galena, and blende—one is impressed by the necessity of having recourse to the most modern practice, whether for getting the silver and gold into solution or for recovering the solution from the pulp for precipitation of the precious metal.

There is but little new either in roasting or concentration of gold ores this year. Merton and Edwards still hold the field for roasting, and the many flotation processes applied to the zinc-lead ores at Broken Hill, such as the Potter, Delprat, De Bavay, Cattermole, and Elmore, do not yet appear to be successfully running at any gold mines known to me, although it is thought that the mechanical and metallurgical skill at the back of the Elmore process will bring it to the forefront during the coming year.

THE DOS ESTRELLAS MILL

(February 8, 1908)

By AN OCCASIONAL CONTRIBUTOR

The mines and two mills of the Compañía Minera Las Dos Estrellas are in the Talpukahua district, in the State of Michoacan, but within three miles of El Oro, in the State of Mexico. In fact the Dos Estrellas, geologically speaking, is in the same district as the mines of El Oro. The principal vein of the Dos Estrellas strikes through a schist, capped by an andesite, like the parallel lode of the El Oro mine. Its strike is nearly northwest-southeast, with a dip of 70° . It is opened by two adits, both equipped with double tracks and electric haulage. Six Baldwin-Westinghouse 5-ton locomotives are in use. The first adit is 700 m. long, the second 580 m. Near the portal of the first adit is mill No. 1, which has been in operation several years. At the entrance to the second adit is mill No. 2, which is practically a new plant. The two adits, nearly parallel to each other, are over half a mile apart and both cut the main vein at the same angle and on the same level, and at such depth as to give a great amount of stoping ground above the haulage level. The width of the main vein, which is called the Veta Verde, is stated to average about 15 m., the length of the ore-shoot being 2000 m. The gangue is quartz. That part of the property opened by adit No. 1 is known as the Dos Estrellas and that opened by adit No. 2 is called the Cedro. The ore from the Dos Estrellas carries 12 to 15 gm. gold and 200 to 240 gm. silver; that from the Cedro carries 10 to 13 gm. gold and 95 to 120 gm. silver. The ores from both parts are highly silicious. The silver is in the form of sulphide and chloride, as well as native; the gold is partly free and partly mixed with the silver sulphide. Besides the principal vein, the company has three other veins of sulphide ore. These are opened by cross-cuts driven from the workings on the principal vein. These sulphide veins are being developed and the ore from them is now

being milled. As this ore requires wet concentration, it is probable that a suitable equipment may be installed later. The mine is fully equipped with electric appliances, with transformers underground, the workings being illuminated by the electricity that comes from the Hecaxa falls, 300 km. distant.

The ores from the principal vein are crushed in stamp-batteries, classified, re-ground in tube-mills, and subjected to cyanide treatment for the extraction of the gold and silver. Mill No. 1 has 130 stamps, crushing the ore in a cyanide solution through 20 to 30-mesh screens. In passing from the batteries to the tube-mills the pulp is so classified as to separate the slime from the sand. There are four tube-mills in this plant, each 24 ft. long by 5 ft. diam., lined with El Oro ribbed lining, cast from chrome steel and scrap iron. It is stated that one set of such liners has been in use 11 months. The tube-mills reduce the pulp so that 75% of it will pass 80-mesh screens. This product is classified in cones, the overflow slime passing to agitating-vats, and the sand to the sand-vats for leaching. First the sand is given washes of 0.22% cyanide solution, then discharged into a second set of vats, in which is given washes of 0.4% solution, and this is followed by washes of 0.12% solution. In the slime treatment part of the decanted solution passes to the zinc-boxes and the remainder is pumped to the return-solution vats that supply the batteries. The stamp-duty in this mill is 3.48 tons per stamp in 24 hr. Burt filter-presses are being installed here to handle the final slime. In this mill 43% of the material is treated as sand and 57% as slime.

Mill No. 2 has 120 stamps, crushing in cyanide solution. This is followed by classification, tube-mill pulverization, and cyanidation of the sand and slime separately as in mill No. 1. Here are five tube-mills in operation. They are the Allis-Chalmers type, 24 by 5 ft. The tube-mill product is divided as 36% sand and 64% slime. Of the sands, 57% will pass 80-mesh screens and 12 to 15% will pass 200-mesh. The sand, after passing to sand-receivers, thence to leaching-vats, is first given washes of 0.4% solution, followed by washes of 0.12% solution. The sand is discharged by Blaisdell excavators and Robins conveyors. A 48-ft. tailing-wheel is being installed for elevating a portion of the material to be re-ground in the tube-mills. In this plant all the slime that overflows from the classifiers is treated to mechanical agitation and decantation in vats 36 to 10 ft. The discharge is run from these vats into others that are 36 by 20 ft., where the slime receives continuous agitation for 20 hr., thence to another set of vats 36 by 20 ft. in size, without agitators, for final settling. The Burt filters are also being installed in this mill. The stamp-duty in mill No. 2 is 3.55 tons per stamp in 24 hours.

The precipitate at mill No. 1 carries 75% metal, at No. 2 about 60%. In both mills they use 100 gm. of lead acetate per ton of ore and about 8 to 10 kg. lime. The cyanide consumption amounts to 1.33 lb. per ton of ore. An extraction of 88% of the gold and 64.5% of the silver is obtained in mill No. 1; in mill No. 2 the extraction

is 90% of the gold and 53.4% of the silver. This is for the first 11 months of 1907. Both mills are run by electricity.

The average operating costs per ton for the first 10 months of 1907 are as follows (on 259,789 dry tons—the production for the 10 months):

	Pesos.
Milling	1.24
Cyaniding	1.70
Mining (including development at the rate of 1100 m. per month)	4.96
Assaying	0.07
General expenses	0.91
Taxes on ore	0.30
	9.18

The railroad from El Oro to the Dos Estrellas mills belongs to the Dos Estrellas company and is being changed to an electric line. The Dos Estrellas property belongs to F. J. Fournier and associates. On the operating staff are the following: Henri Bossuat, general manager; H. Jouanen, assistant manager; G. Gonzales and O. Lopez, mine superintendents; Walter Neal, superintendent of cyanide work; Thos. Dwyer, superintendent of mill No. 1, and W. H. Armstrong of Mill No. 2.

THE EL ORO TUBE-MILL LINING

(February 29, 1908)

The Editor:

Sir—The large number of claimants of the El Oro tube-mill lining who have recently appeared presents an amusing as well as gratifying commentary on the value of the device. The latest contribution, that of Mr. Arthur De Wint Foote, published in your issue of February 1, and the editorial comment upon it, are the most entertaining dissertations on the subject that have yet appeared. Neither, however, are important, in that they do not seriously touch on the essence of the case.

The points of priority of invention, patenting, and practical application still remain with the writer, since the dates given by the various claimants are antedated even by the date of filing of my application for a U. S. patent, which application was made nearly a year after I had originated the device. In the meantime it was being used and perfected by the El Oro Mining & Railway Co. Dates are not matters of opinion, but of fact readily compared and verified. I conceived the idea of the liner in 1905, and filed application for a U. S. patent on June 13, 1906, which patent, No. 864,357, was issued to me on August 27, 1907. The other much discussed claims have all materialized since the lining was first used at El Oro.

Mr. Foote speaks entertainingly of an old boiler-tube mill which he started to make "about three years ago," which was never used. "During the winter of 1906" he made another lining, but does not

narrate the results of operation or whether it was used at all. Mr. Barry of New Zealand invented a lining in which pieces of flinty quartz were "held in cement." Mr. Foote thereupon says of the cast-iron lining used for tube-mills at El Oro: "In many ways it is similar to Barry's." This remark might be equally true of almost all forms of tube-mill lining, which are necessarily similar in many ways. Mr. Barry's lining, however, omits the essential feature of holding the pebbles frictionally in place. In his lining the flint is cemented in place. In the El Oro lining the pebbles are hammered by each other into the channels, thus automatically forming a flint lining. To accomplish this the channels are wider at the opening than at the bottom. As a pebble becomes fractured or worn and escapes from the channel the vacancy is automatically re-filled by a suitable pebble from the charge. There was no record or patent in existence of this essential feature before I conceived it. Cementing the silex in place is a widely different and vastly inferior method of procedure.

Recently a well-known manufacturing company has issued a letter offering for sale a lining "which will accomplish the same end"; this may also be "in many ways similar to Barry's" and yet not possess that feature essential for success which I claim to have discovered, namely, the automatic wedging or holding by frictional contact of a portion of the pebbles of a charge in place to form the grinding surface of the mill, and in this way protecting the iron from wear.

Mr. Hardinge admits that his Mexican patent was issued to him under date of February 22, 1907; so we need not further pursue the inventor of the conical tube-mill.

Mr. C. E. Rhodes' letter in the *Mining and Scientific Press* of December 21, 1907, also states, in addition to what Mr. Foote quotes, that "the rib liner mentioned was invented by J. R. Brown while in the employ of the El Oro Mining & Railway Co." In his letter in *The Engineering and Mining Journal* of December 14, 1907, Mr. Rhodes further states that the lining was used "at the plant of the El Oro Mining & Railway Co. considerably more than two years ago." These statements indicate that the lining was invented by me in 1905, which is confirmed by the date of the filing of my application. During the time the lining was being perfected Mr. Rhodes was cyanide superintendent of the Dos Estrellas company.

O. Crimmann and R. Riley obtained a Mexican patent dated August 29, 1907, for a lining in which the channels are smaller at the opening than at the bottom. Such an arrangement allows the pebbles to enter the channels where, if held at all, they remain loose without presenting a fixed grinding surface. It is significant to note that Mr. Riley was foundry foreman at the El Oro Mining & Railway Co. at the time the El Oro lining was developed. His form of lining is copied from one of the earliest linings, which I discarded, finding after experiments that the principle was wrong.

Mr. Foote's admonition to "Render unto Caesar the things which be Caesar's" applies, in my modest opinion, to the equally

well-known name of the writer. If the lining really was used in Caesar's time, as Mr. Foote intimates, I give up; but if at any time later I claim it. Some time ago I arrived at the decision advocated by you, sir, to "perfect and manufacture the device and show others how to use it successfully." This I have done by associating with the Blaisdell company, with whom I am working, with some degree of success, to market and exploit the lining.

It is my desire in this letter to thank my friends who have loyally supported me in this discussion; to assure the mine managers, and others, of my desire to sell to them at a small profit an untainted lining which they may safely buy and use; and to try if possible to lay to rest forevermore the weary wandering ghost of a doubt as to just who is the inventor of the El Oro tube-mill lining.

JOSEPH RODNEY BROWN.

Los Angeles, February 10.

CRUSHING ORE

By M. P. Boss

(March 14, 1908)

*A true seeker of knowledge is not content to know of a fact without knowing why it is a fact and to be able to fully analyze it. To an engineer and expert capable of intelligently analyzing a matter or condition, the bare knowledge of a fact seems not fully conclusive, without the application of the test of enlightened reasoning, and to him, capability to analyze correctly, counts for more than a bundle of information supposedly correct. The latter may be bought in books, for a dollar or two, while the former is the judgment and personality of the man and is transferable only by reflection. It is the object in the following pages to elucidate some fundamental principles, as the writer has found them, and to put the student mind in a train of analytic reasoning, upon the subject in hand. There has been and is such a multiplicity of devices to make coarse ore fine, that it would be a great undertaking to treat the subject exhaustively, and such is not the object of this essay.

Ores and rock for commercial purposes, taken from the earth, are crushed to a degree of fineness suitable to requirements, which may be as coarse as several inches in diameter or it may be too fine for measurement. An example of extreme fineness may be seen in water that is slightly discolored by earthy matter after having been for some time in repose. Each piece or particle so crushed represents fracture or cleavage to the extent of its superficial area. Rock fractures are irregular and particles resulting from fracturing are variable in size. They can be measured with only approximate correctness by passing them through apertures of a specific size A, followed by passing over apertures of smaller size B, and the product

*Copyrighted, 1908, by the *Mining and Scientific Press* for the author.

that does not pass B may be described as passing A but not passing B. But even this approximation is subject to variation with different types of crushing. The product from some crushing may be slivered and angular, while from other methods of crushing it may be worn and rounded. The sum of areas of fracture in an accumulation of crushed particles is not computable, but to give to the mind some approximate conception we may assume that a cubic inch of quartz (or other substance) is fractured into true and equal cubes 0.002 inch in diameter. This would represent an area of fracture or cleavage of 1500 square inches, minus six square inches (the superficial area of the one cubic inch) or 1494 sq. in. actual fracture. A cubic foot thus divided would represent 17,994 sq. ft. of fracture or cleavage area, and 13 sq. ft. of fracture, or, approximately, one ton would represent an area of 233,967 sq. ft. of cleavage.

Fracture that is effected mechanically represents a consumption of power proportionate to the hardness and toughness of the material, plus the loss in the mechanical application. In all power applied mechanically there is necessarily a loss in friction of the mechanism, and in power applied to crushing ore there is also a loss in its application to the rock being crushed. Wear of parts in contact with the rock represents a part of this loss. There may be a serious loss of power within the mass of material being crushed, by friction and by compression, that is ineffectual in crushing.

Ore is crushed by compression between two crushing members; by grinding between two crushing members; or by impact against a crushing member. A crushing device to be effective must not only have power applied economically to the crushing proper, but it must systematically and properly supply fresh material to the crushing and as systematically discharge the material when sufficiently crushed. Hence we may, for convenience and analysis, segregate the crushing of ore, as popularly considered, into three stages, thus: Supply, getting the material into the crushing field; fracturing, or the act of actual crushing; and discharge, getting the properly crushed material away from the crushing field. Errors of design for crushing are less conspicuous to the ordinary observer in the first and third stages than in fracturing. Crushing devices may be continuous in action upon a material or they may be periodic. Crushing devices of periodic action may be cumulative of power during the non-crushing moment, or they may be non-cumulative. Chilean mills, rolls, barrels, and disc grinders are examples of continuous action. Stamps accumulate power while they are being raised, all of which, less the friction involved, is expended at the moment of arrest from fall. Jaw and gyratory crushers are periodic in action and non-cumulative, except in the equalizing effect of the fly-wheel.

Crushing between two members may be classified: 1. Faces parallel and reciprocal in action, exemplified by the stamp. 2. Faces parallel and non-reciprocal, as exemplified by grinding pans and disc grinders. 3. Two vertical and more or less diverging plane surfaces, with reciprocal action exemplified by jaw-crushers. 4. A circular member, with internal face, within which operates a smaller

circular member with external face, the axis of which is a revolving incline, popularly called gyratory. 5. A plane surface over which passes a cylindrical one, having a horizontal axis, exemplified by



FIG. 20

An enlarged section, showing a particle of ore between two grinding discs, and how it may be fractured, when caught by slightly penetrating the grinding surface.

the Chilean mill. 6. Two cylindrical external surfaces with horizontal axes, exemplified by rolls. 7. A cylindrical internal surface, the axis of which is vertical, within which revolves a smaller cylindrical external surface of vertical or nearly vertical axis, exemplified by the Huntington and Griffin types of mill. 8. A cylindrical internal

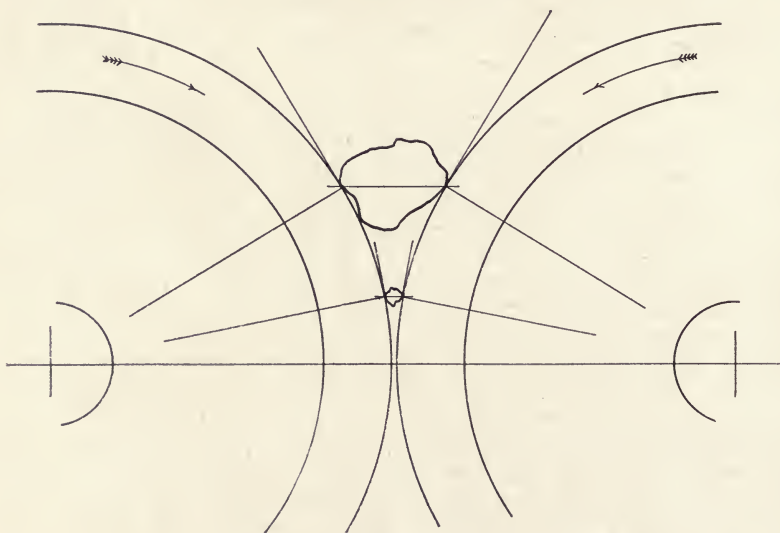

FIG. 21

Rolls showing how pressure lines increase in directness with decreasing size of piece operated upon and how small pieces must be less detrusive in effect than larger ones.

surface, the axis of which is horizontal, within which revolves a smaller cylindrical external surface of horizontal axis.

These several types of crushing between two members have many modifications, some of which do not come within the foregoing description, as, for instance, the Chilean mill sometimes is built with rollers inclined inward, to neutralize the centrifugal energy, in which case the ring-die is properly coned, to give parallel faces to the two

members. Another instance is what might be termed a modification of the grinding pan, substituting a crushing action for that of grinding, by making the muller mildly conical, the axis of which, in operation, is a revolving incline. Crushing by impact against a crushing member is effected: 1st, by hurling it from a rapidly revolving mechanism; 2nd, hurling it by compressed air or steam; 3rd, by dropping it from a height.

Wear of crushing members in action is necessarily constant, but is variable in degree, the chief modifying factors being the quality of the metal of which they are made, the angle of pressure on the surface and the distribution and movement of the material being acted upon. Crushing members that reciprocate and have faces that are parallel or faces that do not greatly diverge at point of pres-

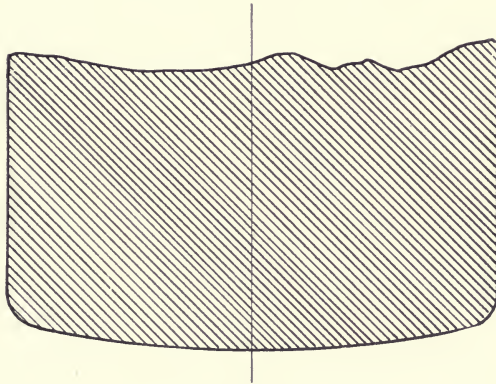

FIG. 22

Section showing convex face of stamp-shoe, approximately as worn by operating upon a thick bit of material.

sure should have extreme hardness as their predominating quality, whereas, faces that are parallel and have a grinding action, or faces that have a wide angle of divergence, toughness should be the predominating quality. A stamp falling directly upon broken ore has chiefly to withstand direct penetration, but a grinder consisting of two parallel discs, pressing axially together, one of which revolves, or the two revolve in opposite directions, have an effect upon grains of material to disintegrate them in two ways: 1st, to wear them away by rubbing over their surfaces; 2nd, to fracture them by detrusive* resistance. (See Fig. 20.)

If the discs are of glassy hardness they will glide over the particles, but if they are less hard and have a quality of toughness, the grains will penetrate the surfaces enough to become caught and ruptured. In the former case the discs will wear proportionately more than in the latter, while the effectiveness in crushing will be less.

*'Detrusion' is the act of thrusting or driving down.—Editor.

Crushing by reciprocal action between two parallel faces results in minimum wear of crushing members, unless modified by conditions. Detrusion of crushing members increases with angle of divergence. Angle of divergence of pressure in a crushing device, having one or both crushing members with an exterior cylindrical face, is greater upon a piece of material of a given size than it is upon a smaller piece of material. (See Fig. 21.)

Compression upon a bed of material between two crushing members will have varying effects, as modified by conditions. If an individual piece contacts two crushing surfaces in line with their approachment, and if the approachment is at right angles with the surfaces, the crushing is accomplished with maximum efficiency, there being minimum friction and loss of power. If the component pieces of a bed of material have less diameter than the thickness of the bed the wedging effect of particles between particles diverts a part of the force in a lateral direction. If the power of compression is sufficient to crush in this diverted lateral direction, it is efficient, but if the bed of material is so thick that the diverted lateral pressure does not crush, the force thus diverted is absorbed and lost.

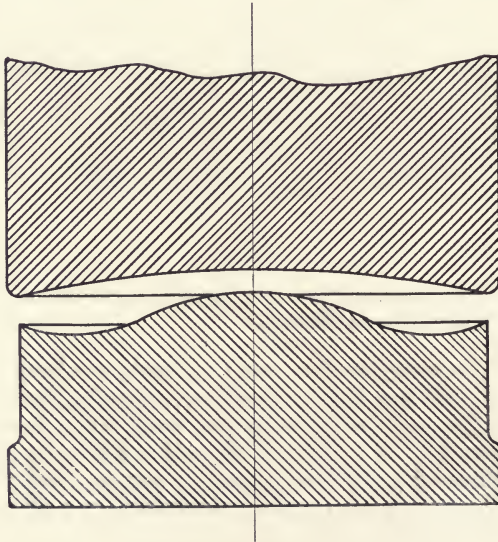

FIG. 23

Section showing faces of stamp-shoe and die, approximately as worn under favorable conditions and with close fitting guides.

A stamp-shoe compressing upon a die, compresses with greatest force at its centre, there being lateral relief at its periphery. If the surface of the die is lower than the discharge, material banks about it, more or less, and there is no detrusion on the periphery below its working face. A shoe in falling is exposed to the attrition at its periphery of pieces lying partly within its path and by particles

being expelled by the lateral diverted force of compression. This results in detrusion of the periphery of the shoe beyond its face.

When a stamp operates in an approximately true path, as with iron guides, compensation for this peripheral wear should be given by making the die smaller in diameter than the shoe.

A stamp-shoe that is operated upon a thin working layer of material over the die wears to a face somewhat concave with a slightly rounded edge at the periphery. (See Fig. 23.)

A stamp-shoe that is operated upon a thick layer of material over the die wears a convex face with well-rounded edge at the periphery. The cause for the first is due to there being but little outwardly expelled material at the shoe contact and the wear being chiefly proportionate to degree of compression, which is greatest at the centre and has lateral relief near the periphery. The cause for a convex face on a stamp-shoe is that in operating upon a thick bed, expulsion of material is confined and restricted and practically equalizes the degree of compression over the bed operated upon and as attrition is greatest away from the centre, the shoe is most worn at and toward its periphery.

While a stamp-shoe and die have been cited as having crushing surfaces parallel, and being practically so when new, in wear they become only approximately parallel. Reasons have been given for the wearing of the face of the shoe away from a straight line and also why the periphery of a die does not wear below its surface. The face of a die under ordinarily good conditions wears declining from the centre to its lowest point a little away from its periphery toward which it gently inclines upward.

Wear on the face of a die is mostly by attrition from the forcing outward over its face, the material under pressure from the effect of the blow of the stamp. The outward movement is least at the centre, but increases toward the periphery, but as the pressure is relieved at that point the detrusion is lessened.

There are idiosyncrasies of wear of crushing members. Deep pockets sometimes wear in dies. The primary cause for these may be a soft spot or a blow-hole, but once started they are increased and deepened by attrition from lateral movement of particles under pressure, by coarser pieces over the depression being forced downward by the blow of the stamp.

The first stage of crushing, that of introducing into the crushing field the material to be crushed, applies not alone to the fresh material but to the re-introduction, or distribution, of material already in process of being crushed. Jaw and gyratory crushers, rolls and disc grinders, that are not grinding pans, act only upon freshly introduced material, which falls away after it has passed the crushing zone. Chilean mills crush only the material that settles upon the path of the rollers and all freshly introduced material as well as all that is insufficiently crushed must continue to lodge upon that path after each passage of the roller, an action that involves some period of time, and limits the efficient speed of the mill. Roller-mills having vertical axes and which crush by centrifugal energy,

operate upon material that is thrown against the path of the rollers by the operation of the mill, for which, time is an element for efficiency, as a roller following its predecessor too quickly will pass before the material has found firm lodgment against the vertical path, or on the other hand, if the roller follows too tardily, the lodgment is at its ebb.

Grinding pans, having two horizontal faces, one of which revolves, operate submerged in a material, from which it feeds without discrimination, and into which it discharges its finished product.

Individual stamps are fed by gravity and rush of semi-liquid material to fill vacancy left by upward moving shoe, and from which place it is in turn violently expelled by the return drop of the stamp. Stamps grouped in mortars are fed by splash from other stamps, as well as by back flow.

A device that is best adapted for coarse crushing is not well adapted to fine crushing. It seems quite natural to classify crushing into three stages: coarse, medium, and fine.

For crushing from coarse to medium, jaw and gyratory crushers are mostly used; for crushing from medium to fine, stamps, Chilean mills, and rolls are most prevalent; and for a very fine product, tube-mills, Chilean mills, and grinding pans. On the softer material, centrifugal roller-mills are largely in use, for both medium and for fine grinding.

In both jaw and gyratory crushers the material reaches the crushing field and also discharges from it by gravity, without frictional loss. With these machines, however, there is an important loss by friction of the mechanism, by detrusion, and by the lateral divergence of force that does not crush.

A stamp falling upon a die over which there is a depth of some inches of water, with ore in proper quantity for effective crushing, displaces water and fine particles with great energy, not only to the extent of the cubic measurement of the submerged part of the stamp, but the surrounding water and material is driven outward and upward by that which is so rapidly forced horizontally outward from under the shoe. In this action, at the moment before the arrest of fall, the water is rushed outward over the underlying larger pieces of material with much force, washing by this means the finer particles from under the shoe before the moment of crushing.

The natural course of the material expelled from under the shoe is parabolic, the initial movement being horizontal and its direction of least resistance upward. At the rise of the stamp and into the vacuum created, water rushes and pieces drop back by gravity, and when other stamps are dropping into the same mortar, the splash from these other stamps adds to the amount to receive the succeeding blow. If, however, the die is but little submerged, when the stamp is at rest, the expulsion of water, at the fall of the stamp, being so much less, the washing effect over the face of the die is proportionately milder, the parabolic course less pronounced and the splash over the screen is weak and limited; especially is this

the case if the mortar is wide. Under such circumstances a portion of the sufficiently crushed material splashed screenward fails to reach exposure over the screen surface, from the effect of the expelling blow. Ore that is easily crushed thickens the water that is used in the crushing, much more than does a hard tough ore. The requirements for crushing such an ore are not so exacting as to width of mortar. The thicker pulp keeps more in mass to resist the falling stamp and surges better over the screen surface, whether it is wide or narrow.

A stamp dropping 100 times per minute and crushing 6 tons in 24 hours, would crush an average of $\frac{1}{12}$ of a pound at each blow, or less than a depth of $\frac{1}{32}$ of an inch over a die $8\frac{1}{2}$ inches in diameter.

As the faces of stamp-shoes and dies do not coincide closely in outline, it follows that most of the finely crushed material is produced by the effective pressure of particles between particles. The concave face of the shoe serves to confine the particles under pressure within, against lateral pressure. Under such conditions the crushing efficiency increases with the force of the blow. The force of a blow from a gravity-stamp is due to weight of stamp and length of drop.

A heavy stamp occupies but little more mill-space than a light one and has no more working parts. Its manipulation in re-shoeing and repairs is, however, more laborious.

A stamp dropping evenly upon a die that is unconfined, expels radially with equal force. If the die is encompassed by a concentric wall sloping so as mildly to compress the natural parabolic line of discharge, and if at proper height this wall has above it a concentric screen properly affixed, the expulsion from under the stamp and upward over the screen, and the return of the coarser particles by their gravity and the suction from the rising stamp is regular and even throughout, and the exposure to the screen-surface of the particles direct from under the stamp is at a maximum. Any break or disturbance from this even course is necessarily a departure from the maximum. A stamp dropping upon a die that is one of a group within a mortar, dispels over a screen-surface only a fraction of its product and an important percentage of the passable product returns again to the crushing field. In the former case, a minimum amount of slime is made and a high proportion of screened product nearly up to passable screen size, whereas, by the latter, slime is made and the material discharged through the screen will average finer and the product will be less even in size. Thus under similar conditions, the output from an individual stamp should be greater through a given screen, than from a stamp grouped in a mortar with others. Stamps grouped in a mortar require less room, have less working parts, and are simpler to operate than a like number of individual stamps.

The gravity-stamp is a mechanism of simple construction and its wearing parts are easily renewable. The regularly recurring drop of stamps, in action, generates vibration of the foundation and

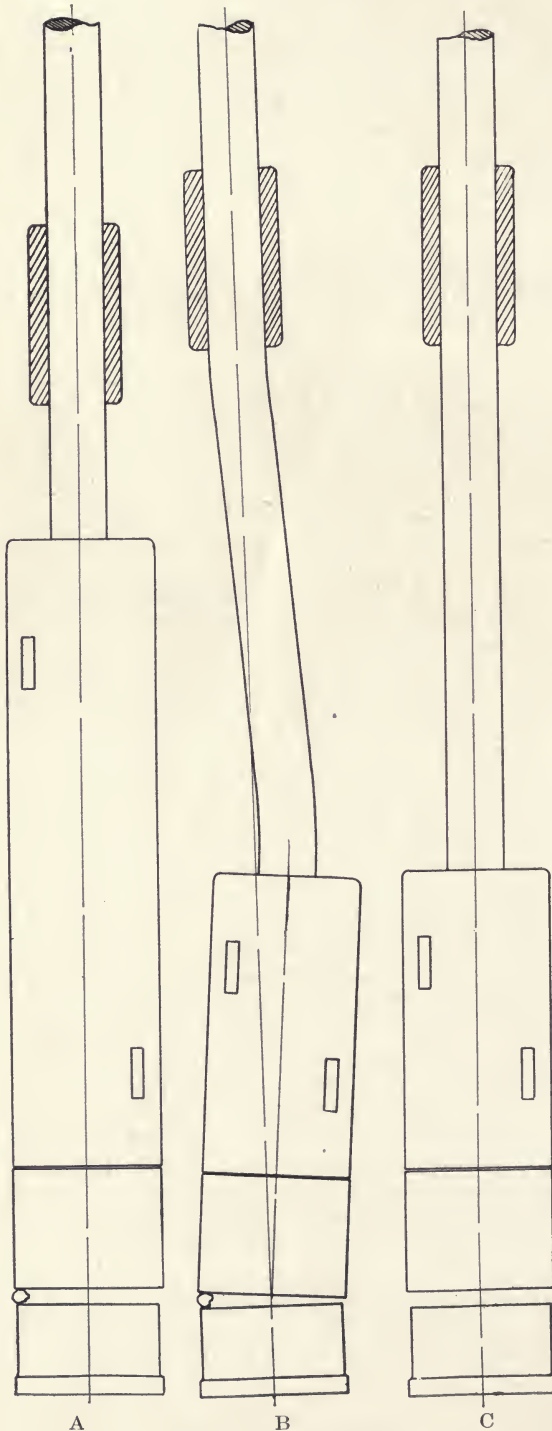

FIG. 24

A shows a stamp of common design and proportions. B is the same stamp, showing (by exaggeration) how the stem is caused to spring. The spring is followed by vibration and continued vibrations cause stem breakages. C shows how stem vibration is so minimized that breakage of stems rarely occurs. A long stamp-head, with the lower guide set low, permits but little spring.

framework, which is the one trying element of construction. An individual blow from a stamp creates but small square-inch pressure at the bottom of the mortar, but the rhythmic recurrence of drops vibrates even the earth upon which it stands, sometimes noticeable hundreds of feet underground. There are two sources from which this vibration is generated; first, from the cam-shaft in picking up the stamps, and second, from the mortar that receives the blows. Low and flat foundations are better to minimize vibration than high pedestals.

The vibration in the stem of the stamp is distinct from, and independent of, the vibration in the foundations of the battery. The material upon which a stamp falls is uneven in size and is not evenly distributed over the die, so that the arrest of the blow will usually be mostly away from the axial centre of the stamp, which will give a lateral strain or wrench to the stem. The vibrating effect of this strain upon the stem varies with the structural design. A high centre of gravity of the stamp, the lower guide high above the die, and guides wide apart, are factors conducive to vibration. The stems in such a battery construction usually will begin to break after having been about a year in operation.

By making the stamp-head long and the stem not unnecessarily so, thereby bringing the centre of gravity low, and by putting the lower guide as close to the head as its convenience of operation will admit, the vibration of the stem will be so minimized that breakage is practically eliminated from consideration. Heavy stamps that operate rapidly by steam, upon a thick bed of material, crush largely by particles between particles. They are remarkably efficient for coarse crushing. (Fig. 24.)

A vertical roller running over a horizontal circular track (a Chilean mill) drives liquid pulp before it in a direction tangential to its track, which direction leads away from the crushing zone. If the confining rim or wall of the mill is sloping, the material flows upward in its onward course until its propellant force is abated, at which moment it recedes, more or less, to the crushing zone. If this recession of material is interrupted by an oncoming roller, it in turn obstructs the natural flow generated by that roller. If in the sloping rim there is an encircling belt of screen, the flow over it, if uninterrupted, will be uniform and regular and a high percentage of fine material will be liberated through the screen. On the other hand, if rollers follow one another so quickly that the return of the flow is interrupted, a portion of the confined material, that is sufficiently fine, is restrained from screen contact. Furthermore, if the flow is not interrupted, its containing coarser material will largely have found rest upon the crushing track, in proper position to receive the on-coming roller. In other words, it may be said, if proper space of time elapses between the passing of the rollers, the coarser material gets into position most efficient to the crushing, and if this coarser material has not reached that point of rest, it is an element of obstruction to the systematic exposure of fine material over the screen. (Fig. 25.)

In such a mill as described, more material is deposited upon the outer confines of the track than upon the inner. To remedy or ameliorate this defect, the track is sometimes made the truncate of a cone, instead of being a true plane. In other cases the track is made very narrow, to minimize the difficulty, and yet at other times scrapers are employed to equalize the material over the path.

A vertical roller, the tire to which is cylindrical, passing over a circular track, has a forward slip at the larger circumference of track and a backward slip at its smaller circumference; between the two there is a neutral point where there is no slip. In the operation of crushing rock, this neutral point varies in radial distance from the axis, around which the roller revolves, a hard substance raising the roller clear of other contact would, for the time, become the neutral point, irrespective of its radial distance. With a given width of tire, the slip, in making a circuit, is approximately the same on a track of small diameter as it is over one of large diameter. The percentage of slip to travel is in ratio with diameters. The friction from this slip is a resistance to the departure of the roller from a straight line of travel and augments the outward centrifugal thrust.

All outward thrust that is resisted otherwise than upon the material being crushed is lost force. To utilize this lost energy, different modifications are employed.

If a roller runs upon a circular track, the face of which is an inverted truncate of a cone, it will maintain its equilibrium without thrust, either outward or inward, when the speed is properly gauged to the angle of incline. If, however, the speed is unduly slow there will be an inward thrust upon the shaft collar, but if the speed is excessive, the thrust will be outward. The requisite for speed increases when the roller is more inclined from the vertical. (Fig. 26.)

If the axis of a roller is parallel to a diameter line of the circular track and at a distance behind it, the line of rotation of the roller will be tangent to a radius shorter than the radius of the track. Inasmuch as the roller travels on the track radius, it follows that there must be a side slip to the extent of the difference of length of the two radii. This slip is a resistance counter to centrifugal force and they may be adjusted to entirely neutralize. Thus the resistance to centrifugal energy, in such a case, is wholly through the bed of material. (Fig. 27.)

If a roller having a cylindrical tire, passing over a circular track, is horizontally trunioned to the driving mechanism, at right angles to the roller axis and at some point below it, centrifugal energy exerted above the trunion centre is diverted downward upon the crushing, by the trunion pull. This may be termed a plus quantity. The centrifugal energy below the trunion, in like manner is diverted upward and is a minus quantity. The difference between the two represents the amount of centrifugal energy utilized upon the crushing. The energy that is not utilized is resisted by the trunion. (Fig. 28.)

In the passage of a vertical roller over a circular track which

is a true plane, the material is thrown outward and when it flows back, more of the material is deposited near the outer periphery of the track than farther inward. As at this point the roller slip is forward, the pressure is greater than at the point of neutrality, while where the roller slip is backward, the crushing pressure is less. For these reasons the working efficiency is greater at the point where the slip is forward. This work has an effect upon the working

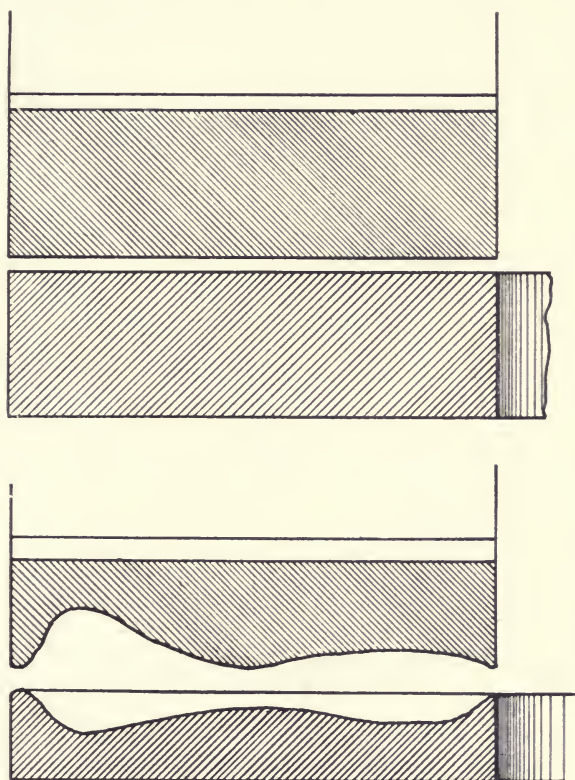

FIG. 25

This is approximately the outlines of wear of tire and track in a Chilean mill having a wide tire and a track of small circumference.

faces of the mechanism that is peculiar and very pronounced, when the roller tire is wide and the path upon which it runs is of small circumference. At the edges of the track the pressure is low because of the lateral relief without the crushing zone. At these points the wear is minimum. A little inward from the outer periphery, where the pressure is greatest the wear is very pronounced and deep. At the neutral point it becomes less again, from which place it increases in depth to a point a little removed from the

inner edge of the track. (Fig. 25.) With this class of crushing, vibration is not an important factor.

From the foregoing, a natural deduction favors a narrow crushing zone, having a track of liberal circumference.

Horizontal rolls do but little crushing of particles between particles and the material passes the crushing field without recurrence. As wear across the face of the roll cannot be true and even, the product cannot be made uniformly very fine, but under conditions where the rock pieces are not so large as to give too obtuse an angle of pressure and where the pieces of ore enter the crushing zone at a speed approximately the same as the periphery of the rolls, the work that they do is with small loss of power. The wear and the care of rolls is a matter of importance.

A horizontal roller running over a track, the face of which is

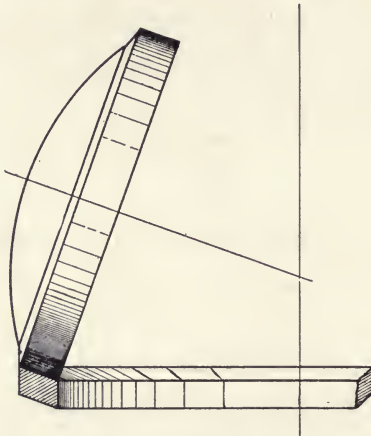

FIG. 26

This shows a Chilean roller operating upon a track that is an inverted truncate of a cone, to neutralize centrifugal thrust.

vertical, acts with centrifugal energy upon the material caught between the two faces. From the nature of conditions, in this class of crushing, there is little crushing of particles between particles, but it is almost wholly done by direct contact between working faces. Speed, to generate pressure, is an essential element with this type of crusher, but the passage of rollers over the path must be properly timed, to catch the material against the track at the proper moment, and it is a requisite condition that the body of moving material shall not be excessive within the mill.

Grinding pans which operate upon a material into which the finished product is discharged, work against a heavy discount of efficiency, as the feed is encumbered with an increasing amount of material that should have been permanently expelled from the crushing field. When grinding between two discs is desired, the highest efficiency and economy is attained by a flow through and

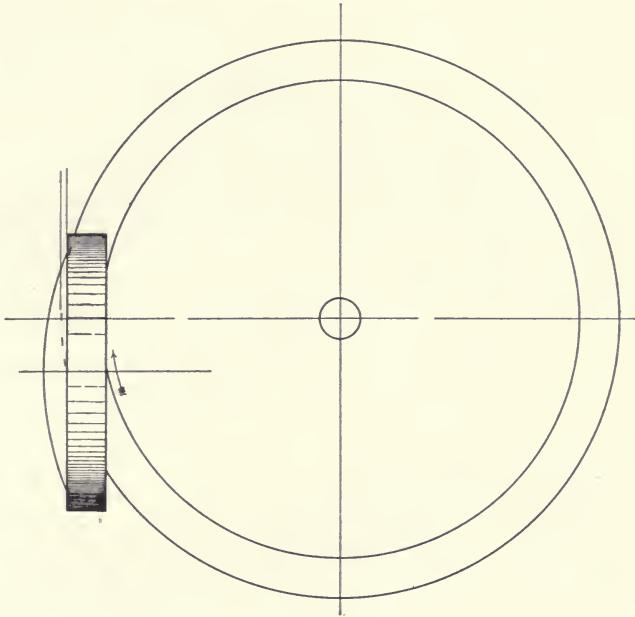

FIG. 27

The axis of this roller is behind the diameter line, but parallel to it, which gives counter resistance to centrifugal thrust.

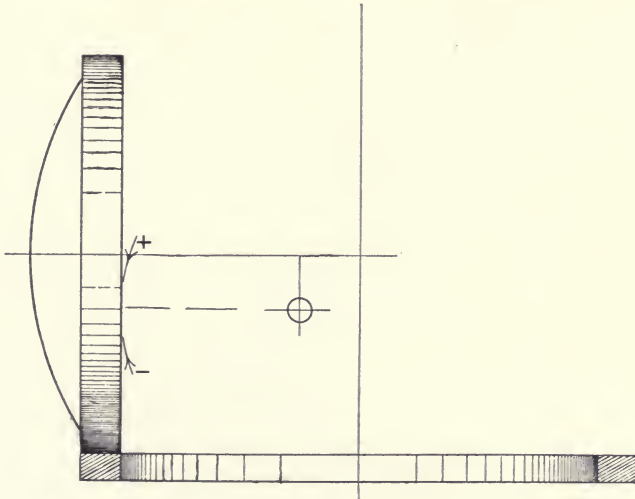

FIG. 28

A trunion centre is here shown in its relation to a Chilean roller, to which it is attached. The downwardly diverted thrust is shown with plus sign and the resisting upward thrust is shown by a minus sign.

away, with the finished product. If the lower disc is made to revolve, it, by centrifugal action, assists the feed between the discs and better keeps alive and in action the material upon it which is being treated. Disc grinders, when properly conditioned, do not altogether rub over and wear away the particles, but they also fracture, more or less, the larger particles. One feature of disc-grinding is, that the coarser particles between the discs are the ones that contact and are acted upon. Discs, to operate with highest efficiency, should contact closely at and near their outer periphery, but should be slightly apart toward their centre, at the point of feed. This is accomplished by cutting open spaces in the discs radially from the centre extending but partly across its base. Disc grinders are very simple in design and of low cost.

Tube-mills containing pebbles for grinding, present an exceedingly great amount of very cheap grinding surface, as each pebble is a grinder. In this feature tube-mills are incomparable with any other class of grinder. However, the material that becomes fine near the feed end must continue on through the tube. Grinding in tube-mills effects no selection of the coarser particles, amidst the pebbles, to be acted upon, but action is with equal facility upon all particles within the field. The loss, within the mill, by friction that is inefficient in grinding is probably great.

From the foregoing, it appears that stamps and Chilean mills, when best constructed and operated, forcefully wash over the material bed, in advance of the crushing moment, and fine material carried by the wash, passes directly to screen exposure. With such action a high percentage of duty is obtained.

Stamps, Chilean mills, and rolls are pioneers in the ore-crushing field. They are each of them simple in design and are durable. It seems probable that they will continue permanently, under various modifications, as popular crushers. Aside from these, there are many devices that have been more or less successfully used, especially in the centrifugal roller class. Sensational claims for peculiar devices appear from time to time, but it must be kept in mind that to put coarse ore that is hard and tough into fine particles consumes power.

MILL-TESTS

(March 28, 1908)

The Editor:

Sir—Descriptions have lately appeared in the technical press giving details of construction and apparatus of testing plants capable of treating large samples of ore. Some of these plants are in reality very complete reduction plants on a small scale, and can treat as many tons of sample, given plenty of time, as may be desired. In one of these descriptions the statement was made that small preliminary tests were made as guides for the large final test, and that the results of the large and small tests rarely differed more than 5%. I think this will be admitted to be the case in

almost all testing works, and there is no question in my mind as to which test is the more nearly accurate or more nearly represents the results that will be attained in a proper mill. The larger or mill-test bears a very close resemblance to the first few days run of a new plant, during which the best results are rarely expected and never attained.

Recently a number of tests on lots of 200 lb. each have been made by Mr. Empsom, preliminary to the design of a 1000-ton mill and cyanide plant at La Luz, in this State. The tests were numerous and exhaustive, covering fine-grinding, air-agitation, and concentration. Now if a mill-test were to follow these laboratory tests, it would be along the lines of the small test that gave the best result, and would add little if any to the knowledge of the ore already acquired. It may be said that the mill-test gives data as to the actual cost of crushing, but in the present case, where the mill will consist of 200 or more stamps, and, in fact, in any case where the projected plant will be much larger than the sample plant, a test in a small mill would appear to be of little use for this purpose. Perhaps an expression of opinion from those contrary-minded, with reasons for their opinions, will put me right, and be of interest to others.

MARK R. LAMB.

Guanajuato, March 8.

TUBE-MILL LINING

(March 28, 1908)

The Editor:

Sir—In reply to the letter of C. E. Rhodes, in *The Engineering and Mining Journal*, I had written claiming the credit for the El Oro tube-mill lining for J. R. Brown, whose name until then I had not seen associated with this invention. A circular reached me from the Blaisdell company of Los Angeles, acknowledging the origin of this plate, consequently I did not forward my contribution to the discussion in your paper.

In view of Mr. Rhodes' letter in your issue of December 21, 1907, I may possibly be pardoned for quoting this letter in part: "Tube-mills were first used at El Oro commercially on the completion of mill No. 2, about the beginning of 1905. The liners used were the chilled castings from Krupp's foundry, which supplied the mills. Subsequently liners were cast at the foundry of the El Oro company. Several innovations were tried, but it was not until about the beginning of 1906 that a sketch was delivered by Mr. Brown, who was in active charge of the tube-mills, to the mechanical department, then under my control. If I am not greatly in error, the idea of the corrugations on the plates was primarily to give the pebbles a chance of greater lift, and at the same time expose a greater thickness to their abrasive action. I suspect, therefore, that, like so many other useful inventions, the wedging of the pebbles, forming a silex lining, was more 'by luck than by cunning'."

Mr. Rhodes is apparently not of this opinion. I give here with a sketch of the original ribbed plate, as designed by Mr. Brown, which is very different from the amended plate as shown in the photographs. Presuming this to be the case, I do not know that the consequent discovery of the wedging of the pebbles, forming a siliceous lining, detracts from the merit due to the originator, any more than the traditional discovery of the expansion of steam by James Watt, by an observation of the lid of the kettle, suffers discount from

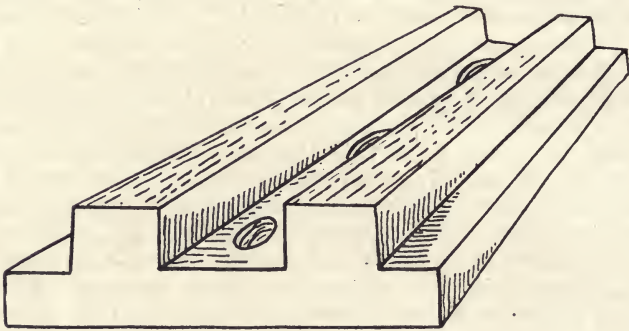

FIG. 29. EL ORO RIBBED PLATE

the fact that that gentleman did not place the identical kettle on the hob to observe the phenomena due to the generated steam. Both gentleman profited by their observations.

Since writing the above I have noticed in the *Mining Journal*, London, in connection with the Waihi Grand Junction Co., Ltd., New Zealand, that there also a gentleman, named F. C. Brown, has invented a ribbed plate for tube-mill liners, described in the words of the chairman, as follows:

“The coarsely crushed ore passes direct into tube-mills fitted with Brown’s patent hard iron-ribbed liners, and is reduced to the required state of fineness. The great economy and efficiency of mills fitted with these liners, I think, arises from the fact that the flint pebbles are lifted by the ribs and fall in a cascade, whereas in other mills the pebbles merely slip round on a smooth surface, grinding away to a great extent to waste. The first one fitted at Komata ran continuously for 18 months, having ground over 27,000 tons of intensely hard and very coarsely crushed quartz, the liners then only being partly worked away, and as since a further improvement has been made in design, it is safe to calculate the life of a liner is, at least, two years.”

It would, therefore, appear (unless there is some connection) that these two gentlemen of similar name have developed along similar lines the ribbed liner. It would seem, however, in the latter case, that the part played by the pebbles in wedging themselves, forming a siliceous lining, has not been recognized or, at least, acknowledged.

This similar evolution of the liner is not without interest, and

renders plausible, if not probable, the remarks at the close of the above letter, regarding the prototype of the El Oro liner.

H. E. WEST.

Akmolinsk, Siberia, February 2.

The Editor:

Sir—In your issue of February 29, in an article by J. R. Brown on the ribbed form of tube-mill lining, Mr. Brown says: "Mr. Hardinge admits that his Mexican patent was issued to him under date of February 22, 1907, so we need not further pursue the inventor of the conical tube-mill. * * * O. Crimmann and R. Riley obtained a Mexican patent, dated August 29, 1907. * * * If the lining really was used in Caesar's time, as Mr. Foote intimates, I give up; but if at any later time, I claim it." Mr. Brown also says that it is his desire to sell at a small profit an "untainted lining" which mill-men may safely buy and use.

The inventor of the conical mill has not been aware of being the object of pursuit, unless the article in your issue of December 21 (page 775) on this same subject was intended as such. In answer to the latter we must admit having written a reply, which finally found a resting place in our waste-paper basket, for which act of consideration to you and your readers, we accept their unrecorded thanks. As it is highly probable that this form of lining may in the future be of interest to users of tube-mills, and in order that Caesar and Brown may receive their due, we ask what Brown's U. S. patent has to do with Hardinge's Mexican, or his other foreign, patents covering the device.

Let us consider in chronological order, the claimants for the honors (dollars) for first prescribing a remedy or preventive for the dyspeptic disorders to which the tube-mill is heir, as follows:

Foote claims no patent, but it is allowed that he is a philanthropic good fellow.

Hardinge first practically applied the rib form of lining to a 150-ton conical (tube) mill in January, 1906; he applied for U. S. patent for mill-lining long previous to June 13, 1906. The exact date is still an unpublished record in the U. S. Patent Office.

Brown applied for U. S. patent on June 13, 1906.

Riley applied for Mexican patent six months after the issuance of Hardinge's Mexican patent, covering conical mill and ribbed lining.

In this we do not wish to be understood as "pursuing" Mr. Brown, simply enjoying the parade of facts and figures from "up a tree" while dates are undergoing judicial investigation.

In an endeavor to repay the weary reader for his time, as well as affording me an opportunity to present my credentials for a perch upon the same philanthropic rail as that occupied by my co-worker, Mr. Foote, and not entirely malapropos to the above discussion, allow me to suggest that a satisfactory lining for launder bottoms can be made of light cast-iron plates with ribs about $\frac{3}{4}$ in.

high and $\frac{3}{4}$ in. apart, spaced in staggered lengths of 3 or 4 in. as indicated in the accompanying sketch (1 and 2 of Fig. 30), between the ribs of which the coarser sand will be retained, especially jig products, forming a lining that constantly renews itself, until the ribs themselves are worn away. This will be an order to the Public

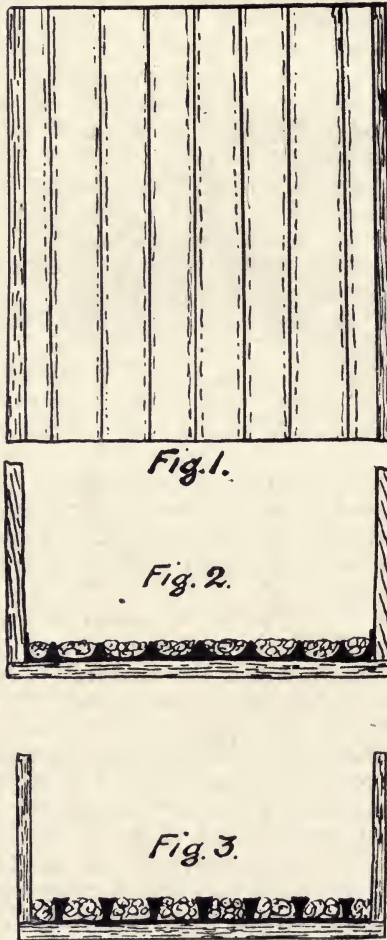

FIG. 30. LINING FOR BOTTOM OF LAUNDERS

upon the El Paso Foundry to permit the use of my plans and blue-prints, from which they furnished several hundred feet of this lining in 1901—no patents applied for. The objection to the pointed form of rib shown in the sketch, is that the wearing away of the top portion gradually releases the enclosed particles, which ultimately drop out owing to want of adhesive walls. An improvement over my

earlier style of launder plates is shown in Fig. 3, which, however, would be more difficult to cast and would consequently cost more.

H. W. HARDINGE.

New York, March 9.

[On tube-mills Mr. Hardinge goes strong, and we are glad to publish his letter, together with the note on launder-bottoms. We add a replica of the drawings accompanying the U. S. patent, No. 864,357, granted to Mr. Brown, which is interesting in view of these letters from Messrs. West and Hardinge. The pleasant controversy over this rib-lining is only another exemplification of the fact that

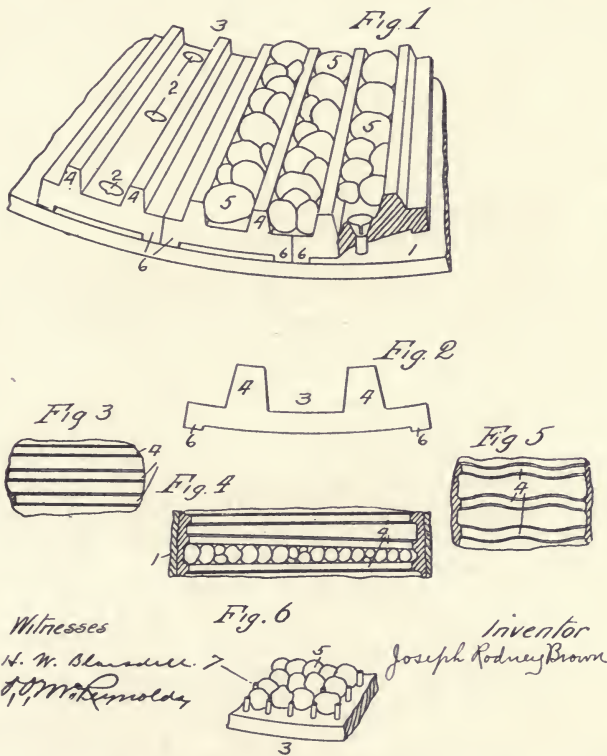

FIG. 31. LINING FOR GRINDING MILLS (Patented by J. R. Brown)

the best proof of the value of an invention is the simultaneous discovery of it by several men independently.—EDITOR.]

SODIUM CYANIDE

(May 16, 1908)

The Editor:

Sir—The article on 'Passivity of Gold' in your issue of March 28, agrees with our experience at this plant with the two forms of commercial cyanide containing, respectively, potassium, 98 to 99%, and sodium, 125%. The question to a mill-man is as follows: When he buys sodium cyanide, having in view the lesser bulk and consequently cheaper freight rate, does he actually have an excess of 25% in efficiency over the old form of potassium cyanide?

In the cyanide department of the Daly Reduction Co.'s mill, the average consumption of sodium cyanide during a period of five months was 1.35 lb. per ton of ore treated, or in terms of potassium cyanide, 1.69 lb. per ton. Trouble was found in bringing up the working mill-solutions to the desired strength, by the addition of the calculated required amount of sodium cyanide. Clean laboratory solutions of sodium cyanide titrated correctly, showing that the salt was of required purity. In the working mill-solutions, however, it was constantly necessary to add an excess of sodium cyanide above the calculated amount, to obtain the desired strength of solution.

We changed to potassium cyanide. At the present time, and after a period covering seven months, the average consumption of this salt is 1.46 lb. per ton of ore treated, or a saving over the sodium cyanide of 4 cents per ton of ore, in terms of the prices at this place. This result has been reached with the same class of ore in each case, and with the same percentage of protective alkali.

With sodium cyanide solutions, the zinc-boxes were troublesome. The zinc coated badly, and after a short time action ceased, making frequent clean-ups and washing necessary. With the closest attention our sump solutions averaged 20 cents per ton in gold. With potassium cyanide, the zinc-boxes are not uncovered more than five times a month, and an average sump solution is not in excess of 6 cents per ton.

The above has held true to a greater or less degree with ores previously encountered at Gould, Montana, and at Zortman, Montana.

E. A. HOLBROOK.

Hedley, B. C., April 13.

CYANIDING MILL-PULP AFTER AMALGAMATION

(May 16, 1908)

The Editor:

Sir—The examination of an average pulp produced after preliminary crushing in stamp-batteries or other mills, after it has been treated by plate amalgamation, would prove that the different sizes vary as regards specific gravity and mineral composition, as they are known to do in value. In one case the following averages of

sizing tests of daily samples, representing a period of 14 days, are given. The pulp after amalgamation was sized, and each size assayed, with the following results:

Mesh.	Per cent.	Dwt. fine gold.
+ 60	14.6	8.8
+ 90	16.5	7.9
+ 100	5.8	4.5
+ 150	8.5	2.9
— 150	54.6	1.2

In other words, 54.5%, or more than half, of this pulp contained only 1.3 dwt. gold. The whole was roughly classified, the coarse product re-ground and finally everything was discharged as a so-called slime into vats for cyanide treatment. The cost apparently did not justify cyaniding 1.3 dwt. product, and it was found that much visible gold, escaping amalgamation, could be arrested on blankets. These blankets were strips, 12 in. wide, fixed upon the lower ends of the plates. Possibly by careful classification, a large percentage of the total tonnage of the finest slime carrying low value, might be eliminated and treated by blanket strakes, slime tables, or automatic frames, and thus a considerable percentage of the gold in the slime might be caught inexpensively. The tank capacity available for cyaniding in an all-sliming process would be capable of meeting the requirements of a larger output than was at first intended without incurring the extra expense of enlarging the cyanide department. I think the difference between the first slime produced in a mill and that subsequently obtained by re-grinding is often overlooked. They are really so different that they warrant independent study. In the first instance the softer and more readily pulverized rock constituents, namely, pyrite, aluminous earths, etc., predominate while the portion re-ground has a different character and is more silicious. The question is, whether in an all-sliming process, first slime is worth cyaniding in every case.

CYRIL E. PARSONS.

London, March 7.

RECENT CYANIDE MILL IN MEXICO

(May 23, 1908)

The cyanide plant of the Guanajuato Reduction & Mines Co., started with 80 stamps, milling 250 tons per day, being the first unit of a proposed 1000-ton mill, the second unit of which was put in operation in August 1907. The ore is first crushed through a No. 5 Gates crusher, passes to a sorting-belt, and thence to a trommel with $1\frac{1}{8}$ -in. apertures. The oversize is crushed in a No. 4 D Gates crusher. The mill construction is of steel throughout, the batteries set back to back, 80 on each side. These stamps are all of 1050 lb. weight, making one hundred 8-in. drops per minute. The mortars are set directly upon concrete foundations without anvil block. The stamps are driven in batteries of 40 to a shaft, one 100-hp. motor

driving each 40 stamps. The ore is crushed in 0.04% KCy solution through 26-mesh, 28-gauge, steel-wire screens, and is classified by spitzkasten into two bottom products and an overflow. The coarse product from the first spitzkasten is concentrated over No. 4 Wilfley tables, practically the entire tailing from which is reground in tube-mills. The fine spitzkasten-product is concentrated on No. 4 Wilfleys, the tailing going directly to the cyanide plant. The overflows from the spitzkasten are all elevated to large thickening cones, the bottom product being concentrated on Risdon-Johnston tables, as is also the tube-mill product. There are 24 Wilfley tables, 18 Risdon-Johnston concentrators, and one Overstrom in the mill. Two Abbé tube-mills, 4 ft. 6 in. by 20 ft., do the re-grinding, using silex lining and No. 4 Danish pebbles. The average life of the linings has been eight months.

The mechanical efficiency of the mill is well demonstrated by the fact that during the first year of operation the total loss of possible stamp-hours amounted to only 0.87%, this including all renewals of shoes and dies, screens, belts, etc. The total tailing passes through a tunnel and sampler to 6 thickening cones 20 ft. diam. with 45° sides, the clear overflow being pumped back to the mill-supply tank 22 ft. diam. by 20 ft. high. The thickened product, carrying about four tons of solution to one of pulp, is then introduced into a cast-iron pipe with bell-and-spigot joint, 8 in. diam., $\frac{5}{8}$ in. thick, and 5440 ft. long, which conducts it to the cyanide plant a mile away. This line is laid on a uniform grade of $2\frac{1}{4}\%$ for its entire length, except for the 800 ft. at the head of the line, which has a grade of $3\frac{1}{2}\%$. No difficulty whatever has been experienced in the conveyance of pulp through this line at the thickness mentioned, and after having conveyed 150,000 tons of ore there are no appreciable signs of wear in the pipe.

At the cyanide plant, classification into sand and slime is effected by four 8-ft. cones without ascending current, and the bottom product is again put through sixteen 4-ft. cones with ascending current, the overflow from all cones going direct to the slime-plant. The bottom product of the 4-ft. cones goes through Butters distributors to one of three receiving tanks 48 in. diam. and 8 ft. high, with filter-bottom. These are filled in rotation, drained and discharged through bottom-discharge gates to a conveyor belt system which passes over the centres of 15 leaching vats each 40 ft. diam. by 8 ft. high. After treatment the sand is sluiced into the river; 15-day treatment is given, involving 30 baths of 0.5% and 6 baths of weak stock-solution. The slime is treated by decantation, the residues being passed through a Butters filter. All decanted solutions pass through the zinc-room before returning to the stamp-mill. The Butters filter contains 75 leaves, and handles 220 tons of dry slime per day.

THE RIDGWAY FILTER

(June 6, 1908)

The Editor:

Sir—I am enclosing photograph of the Ridgway filter, hoping that it will be as interesting and instructive to your readers as the machine itself was to me. This particular machine is placed in the Pastita cyanide plant of the Guanajuato Development Co. as an initial unit, to be supplemented by others after this one has demonstrated its ability to treat the slime. These filters are all set up in the factory in England before shipment to customers, and the mechanical operation of the filter (*not* filtering slime) is perfected. The machine is beautifully made. I am not violating confidence in quoting Joseph MacDonald as saying that it is an almost perfect machine from a mechanical point of view. The filter leaf is a flat iron plate cast with corrugations on its under surface. This under

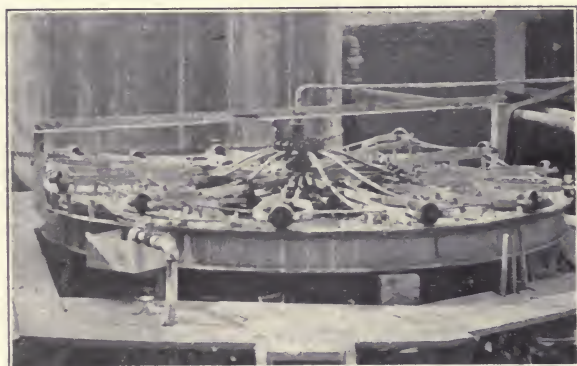

FIG. 32. THE RIDGWAY FILTER IN ELEVATION

surface has an area of over three square feet and is covered with canvas, which serves as the actual filtering surface. These leaves, 14 in number, are arranged to be lowered into pulp during part of their revolution, raised over a partition, and lowered again into a second trough. This second contains water (or solution) for displacing the retained metal-bearing moisture in the slime. The raising and lowering is effected ingeniously by the irregular arrangement of the outer track upon which the leaves are supported. At the moment that the leaf is lowered into the pulp after passing the discharge-hopper the vacuum-valves open automatically. The air-pressure valves are to be opened by a roller-cam when the loaded leaf reaches the discharge-hopper and these valves are timed to the fraction of a second, as are the vacuum-valves. Three of these leaves are continuously immersed in pulp. The compressor that provides the compressed air for discharging the slime is of English manufacture, well made and efficient. The vacuum-pump is a double vertical supplied by Cyanide Plant Supply Co., Ltd., of England, and is the

proverbially well made, neatly finished, and efficient machine from English shops. I omitted to mention that the slime and wash-solution compartments are provided with 10 slow-moving agitators driven through stuffing-boxes from below by a series of cut gears of excellent workmanship with probably very slight friction and wear. The machine has been erected and ready to run for several months, and I cannot emphasize too strongly the excellent workmanship, construction, and materials used.

MARK R. LAMB.

Guanajuato, Mexico, April 24.

SUBMERGED FACTS AND FILTERS

(June 6, 1908)

The Editor:

Sir—The fact that mining and metallurgical publications have, during the past few months, contained several articles and advertisements relative to the exclusive ownership of submerged filters and the details of their construction and operation, suggests that something may yet be said, without impropriety, by those on the outside.

There is no general opposition to the proposition that the man who shows to his fellow-workers a better method or mechanism should receive compensation through the patent laws for the novelty involved in that service, but the public justly resents the patenting of ancient and generally used methods.

Submerged filters long since outgrew protection under patent laws. I made my first acquaintance with them in the year 1865, when the knapsacks of soldiers returning from the civil war were opened for the inspection of the boys at home. A porous clay block, connected with a mouthpiece by a rubber tube, enabled the soldier to lie down by any muddy pool and get a drink of clear water. It may not be unreasonable to assume that no filtering has ever been done without submerging the filter, as the outer and inclosing wall of liquor, however thin, is always present during filtration.

About thirteen years ago millmen were working upon the problem of the separation of slime from liquor in cyanide practice. My own efforts in that direction date from that time, and I remember with more amusement than pride the variety and extent of the scrap-piles that mark that particular pathway. After going to the limit in centrifugal separation, I turned to suction, and drew the liquor through all kinds of filters into cylinders, cones, and boxes, removing the adhering slime-tailing by various devices. Perhaps others approached more closely to the achievement of a sensible working plan and mechanism than I did, but my own methods and appliances were, in the light of the present, crude and not feasible.

In my opinion, George Moore's great service to the cyanide milling industry consists in his truly valuable conception as to the size and shape of filter-cells, making possible the assembling of large filter-area to be handled as a unit. Slime treatment in American

metallurgy was not successful until Mr. Moore gave us his shape of cell, and that form of filter-cell remains a basic principle in the present perfected vacuum-filtration. The many mechanical imperfections in the early construction defeated his purposes and, in his first important test, at Mercur, Utah, condemned his process.

The writer, believing that Mr. Moore had outlined the best system for slime-filtration so far discovered, and that the bad mechanical features could be corrected, advised J. V. N. Dorr to investigate the process and to install it in the Lundberg, Dorr & Wilson mill, then being built near Lead, South Dakota. After study of the Moore slime method, it was adopted by Mr. Dorr, and at his mill the first success was made with the system. Mr. Dorr eliminated much of the original crudeness of the Moore plant, but even after his improvements were introduced there was trouble at various points, and the filter-cells remained so unsatisfactory as to threaten the final condemnation of the Moore slime process.

After study of the process as operated by Mr. Dorr, I was convinced that Mr. Moore's inspiration as to the external shape of filter-area made success possible for vacuum-filtration in cyanide practice, and that his cell construction must be radically changed, and his plant for freeing the filters from the adhering slime-tailing greatly improved, before his system could become useful. Immediately after my observation of the work at Mr. Dorr's mill, I made and used the first perforated iron-pipe framed filter-cell that was ever designed or put into service, and for the internal air-pressure adopted by Mr. Moore for discharging the tailing, I substituted internal liquor-pressure under low head.

The fact that the iron-pipe cell-frame and the internal liquor-pressure are vital to the success of the system in question; and that those new features retrieved from failure vacuum-filtration as applied to cyanide mill-work, have been proved by the failure and abandonment of Mr. Moore's cell-frame and internal air-pressure, and the adoption and present general use of my perforated iron-pipe cell-frame and internal liquor-pressure.

Since satisfactory results in operating filter-cells are dependent upon the incorporation of these latter features, the two leading vendors of slime-filter plants and mill-rights are using them, although both of these companies know that the points are covered by my patents.

The foregoing may have been, hitherto, a submerged fact to many users of my iron-pipe cell-frame and internal water-pressure, but as that fact is soon to become a subject of agitation, and as the matter is of considerable importance to mill-managers who are employing the filters in question, it seems proper at this time to make the above statement.

G. A. DUNCAN.

Nelson, Nevada, April 22.

CYANIDE COSTS

(June 13, 1908)

The Editor:

Sir—In view of the fact that the precipitation and clean-up costs at various cyanide plants have been recently published, the following summary of these costs at the Liberty Bell mill may be of interest. The figures are for the month of March, 1908, and therefore represent present practice; they are complete only as to labor, supplies, and power, and do not include the distributed charges of heating, lighting, superintendence, and depreciation.

Ore milled (tons of 2000 lb.).....	10,548.
Solution through zinc-boxes (tons).....	24,510
Precipitate recovered, washed, and dried (lb.).....	1,275.5
Bullion from same (oz.).....	16,016.8
Metal in precipitate (per cent).....	86.1
Bullion fineness (gold and silver per 1000).....	950

COSTS**PRECIPITATION**

Zinc, 4700 lb. at 8.97c. per lb.....	\$421.60	
Cutting	65.00	
Labor	81.55	
Power and supplies	26.65	
		<u>\$594.80</u>

CLEAN-UP AND FILTER-PRESSING

Labor of cleaning and re-packing boxes, and de-watering precipitate	43.50
(There are 12 five-compartment boxes, each compartment having 20 cu. ft. of zinc space.)	

REFINING

Acid treatment and washing.		
1050 lb. sulphuric acid at 4.6c. per lb.....	\$ 48.30	
Labor	55.30	
Power and repairs	8.45	
	<u>\$112.05</u>	
Drying and melting.		
Coal, 750 lb. at \$6 per ton.....	\$ 2.25	
Coke, 2500 lb. at \$17 per ton.....	21.25	
Flux	32.75	
Crucibles	36.00	
Labor	29.00	
Repairs and sundries	3.05	
	<u>\$124.30</u>	
		<u>\$236.35</u>

Total cost	<u>\$874.65</u>
------------------	-----------------

COST PER TON OF SOLUTION

Precipitation	\$0.0243
Clean-up and filter-pressing	0.0018
Refining	0.0096
	<u>\$0.0357</u>
Total	\$0.0357
Refining cost per Troy ounce of bullion	\$0.0148

W. A. MOULTON.

Telluride, Colorado, May 1.

(July 11, 1908)

The Editor:

Sir—I was interested in the statement of Liberty Bell costs of precipitation and clean-up for the month of March, 1908, as given in your issue of June 13. The figures herewith submitted cover the same costs at the plant of the Desert Power & Mill Co., Millers, Nevada, for the month of May, 1908, and are on the same lines as those given by Mr. Moulton, not including the distributed charges of superintendence and depreciation. They may be interesting for comparison, showing the cost in different localities and under different conditions:

Ore milled, tons of 2000 lb.....	13,830
Solution through zinc-boxes, tons.....	81,000
Precipitate recovered and dried, lb.....	27,947
Bullion from precipitate, oz.....	291,412
Metal in precipitate, per cent.....	71.5
Bullion fineness, gold and silver, per 1000.....	972.6

COSTS

PRECIPITATION

Zinc, 23,733 lb.	
Cut at plant, 15,969 lb. at 9.6c.....	\$1,529.94
Shavings, 7,764 lb. at 13.6c.....	1,006.32
	<hr/>
Cutting 15,969 lb.....	\$2,536.26
Power and supplies	141.00
	222.45
	<hr/>
	\$2,899.71

All solution was pumped through boxes.

CLEAN-UP AND FILTER-PRESSING

Labor of cleaning and re-packing boxes.....	\$ 519.45
Four clean-ups are made per month. (There are 17 seven-compartment boxes, each compartment having 15 cu. ft. for zinc-space.)	
Total zinc capacity, 1785 cu. ft.	

REFINING

Acid treatment of precipitates is not used.	
Drying and melting:	
Coal, 7500 lb., at \$19.44 per ton.....	\$ 72.90
Coke, 31,572 lb., at \$17 per ton.....	268.37

FLUXES

Fluorspar, 158 lb.....	8.41
Borax, 5454 lb.....	418.34
Borax glass, 100 lb.....	20.50
Soda, 2699 lb.....	112.01
Crucibles	167.34
Labor	725.55
Repairs and sundries.....	116.60
Power	18.30
	<hr/>
	1,928.32

Total cost \$5,347.48

COST PER TON OF SOLUTION

Precipitation	\$0.0358
Clean-up and filter-pressing	0.0064
Refining	0.0238
	<hr/>
Total	\$0.0660
Refining cost per Troy ounce of bullion.....	\$0.0066

Labor is paid \$4 per 8-hr. shift, refinery helpers \$4.50 per 8-hr. shift, and two refinery men receive \$160 and \$145, respectively, per month.

A. R. PARSONS.

Tonopah, Nevada, June 16.

(October 17, 1908)

The Editor:

Sir—Can any of your readers supply figures for estimating the amount of royalties paid on the different systems of filtering slime? It is only fair, in estimating the cost of treatment, to include this item in each case, although I have failed to find it in any estimates. If this expense is included in the total cost, it would seem better to segregate it. C. W. Merrill claims to cyanide the Homestake slime for 24 cents per ton. Does this include his royalty?

A. DEL MAR.

Rawhide, Nevada, October 5.

The Editor:

Sir—The data submitted in the following tables show the precipitation-costs, including melting and acid-treatment of zinc shorts at the Pinguico mill, Guanajuato, Mexico, for the month of July, 1908. The table gives the data compared with similar results from the Liberty Bell mill and the Desert mill, the latter figures being taken from the *Mining and Scientific Press* of recent dates.

COMPARISON OF COSTS
PRECIPITATION, MELTING, REFINING

	Liberty Bell.	Desert.	Pinguico.
Ore milled, tons of 2000 lb.....	10,548	13,830	6,927
Solution through boxes, tons.....	24,510	81,000	51,150
Precipitate recovered, lb.....	1,275	27,947	11,026.4
Bullion from precipitate, oz.....	16,016.8	291,412	123,359.5
Metal in precipitate, %.....	86.1	71.5	76.3
Bullion, fineness, Ag and Au.....	980	972.6	925.55
COSTS			
Precipitation—			
Zinc and supplies	594.80	2,899.71	1,180.75
Clean-up and filter-pressing—			
Labor on boxes.....	43.50	519.45	77.56
Refining—			
Acid and labor	112.05	165.37
Drying and melting.....	124.30	1,928.32	606.12
Totals	874.63	5,347.48	2,029.80
COSTS PER TON OF SOLUTION			
Precipitation	0.0243	\$0.0358	\$0.0230
Clean-up and filter-pressing.....	0.0018	0.0064	0.0015
Refining	0.0096	0.0238	0.0150
Totals	\$0.0357	\$0.0660	\$0.0395
Refining cost, per oz. bullion.....	\$0.0148	\$0.0066	\$0.00625
Total cost of precipitation, melting, etc., per oz. bullion	0.0545	0.0183	0.0164

C. E. RHODES.

Guanajuato, Mexico, September 26.

GOLDFIELD, NEVADA

By T. A. RICKARD

(June 20, 1908)

METALLURGICAL DEVELOPMENT

The metallurgist waits on the miner. Until the ore is produced, the mill cannot be supplied. At Goldfield there is a good foundation for an interesting metallurgical practice because a large tonnage of rich ore is available. Already smelting, stamp-milling, cyanidation, and chlorination have been applied successfully.

No process of treatment can be used intelligently until the character of the ore is understood. The Goldfield ore possesses three dominant features: (1) high gold content, (2) the presence of tellurides as well as free gold, and (3) alunite. Owing to its richness, it has been possible to transport the product of this district to distant smelters, at Salt Lake, Denver, and San Francisco, where it forms the silicious part of a charge fed into a blast-furnace. Lead is usually the collecting medium for the precious metals, but copper is also used; although high-grade ore is rarely smelted in the copper furnaces. To the metallurgist in charge of the smelter the Goldfield ore is just so much silica needed to combine with his iron and lime in order to form a slag of suitable fusibility. The richness of the ore affects the sampling more than the actual smelting. Great care is required to obtain a true sample, and it is found necessary to pass a large proportion of a shipment through breakers and rolls before obtaining the fractional portion that is assayed. The alumina in the Goldfield ore retards the fusibility of the slag; usually there is about 7% alumina in the smelting mixture. But, on the whole, the commercial drawback to handling such rich ore is more serious than any technical difficulty; a carload of 40 tons containing \$12,000 worth of gold represents a good deal of money, and it makes a great difference as to when the payment is made. The miner wants his money right away; the smelter would like to postpone payment until he gets his check from the refinery or the mint; between the date of shipment from the mine and the date when the gold and silver in the ore are available as currency, there is an interval of 60 to 90 days. Capital is tied up for three months, the miner objects to waiting, the smelter objects to loaning money even on so good a collateral as gold ore. The result is a compromise by which the miner pays his share—and sometimes more—of the interest on the suspense account.

Most mining districts begin to market their ores by shipment to the nearest smelters or custom-mills. They pay through the nose for treatment and transport, but they cannot escape this tax on their production until the reserves of ore warrant the erection of local mills. Moreover, in the early days of development it is not certain what is to be the average character of the ore and it is not possible therefore to ascertain the most suitable method of reduction. Usually a 5-stamp mill is the pioneer metallurgical unit. At Goldfield, the owners of the Combination mine were the leaders in local metal-

lurgical research. From December 1903 to May 1905 the ore was shipped to the smelters; first it was hauled in wagons to Candelaria, a distance of 65 miles; later, on the completion of the railroad to Tonopah, it was carried thither, a distance of 30 miles. The distance was halved and time was saved, but the cost of transport remained much the same. It was decided to erect a mill at the mine. Tests were made in San Francisco and at the mine by F. L. Bosqui. It was found that crushing dry, followed by cyanidation, left some coarse gold undissolved in the tailing. Amalgamation was needed to supplement cyanidation. A small portion of the oxidized ore carried an excessive amount of acid due to decomposed sulphides. As much as 50 lb. lime per ton was added to neutralize this acid. Finally, an extraction of 90% was obtained on the oxidized ore. The sulphide ore, then unimportant, was more refractory. Pan amalgamation after roasting, concentration with oil, chlorination, and leaching, were tried in turn before it was decided to concentrate the rich gold-bearing pyrite, and cyanide the tailing from the sulphide ore.¹ When these tests had been concluded, a 10-stamp mill was built and to this plant 10 more stamps were subsequently added. The treatment of the sulphide ore is shown diagrammatically in Fig. 33, which is borrowed from Mr. Bosqui's description, already mentioned.

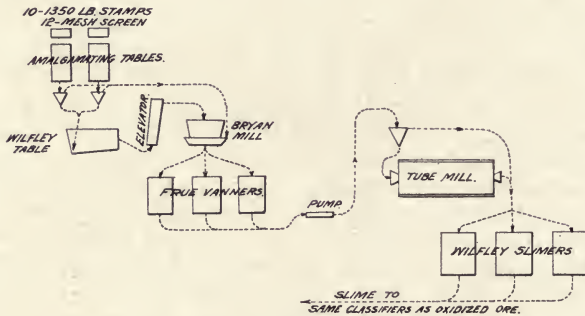

Fig. 33. TREATMENT OF SULPHIDE ORE

The Combination mill does not now impress one as a model plant, simply because it has undergone such successive additions and changes as are destructive to any unity of design, but, such as it is, this mill has solved the metallurgical problems of the district and afforded the information on which newer, larger, and prettier mills are being planned.

Before discussing the milling methods further, let us glance at the ore. It is essentially a silicified dacite enriched with gold. The altered dacite contains² 50% quartz, 24% kaolinite, 15% alunite, 7% pyrite, 2½% water. The alunite and kaolinite are obstacles to

¹ 'Ore Treatment at the Combination Mine,' by Francis L. Bosqui. *Mining and Scientific Press*, October 6, 1906.

² 'Association of Alunite with Gold.' F. L. Ransome. *Economic Geology*. Vol. II, p. 678.

filtering and therefore to leaching. The alunite, being a hyrous sulphate, is destructive of cyanide and requires neutralization with lime. When the altered dacite becomes rich enough in gold to be classed as ore, it becomes more quartzose, the percentage of silica increasing from 50 to 75% or more. The ore contains pyrite (iron sulphide) in small grains, bismuthinite (bismuth sulphide) in needle-shaped steel-gray crystals, and a reddish-gray mineral resembling tetrahedrite (the gray copper of the miner).³ The gold accompanies the gray copper and the bismuthinite, the sulphides being often arranged concentrically around fragments of brecciated dacite. The native gold is rarely coarse. It occurs usually in particles so minute and so closely packed as to resemble a streak of old-gold paint. The proportion of silver to gold is as 65 to 1, so that there is a marked difference compared to Tonopah, where the silver is predominant. The Goldfield ore also contains tellurides, not in important proportion from the mineral-collector's standpoint, but enough to interest the metallurgist. Ransome mentions the occurrence of undetermined tellurides in ore from the Jumbo Extension. Lochiel M. King states⁴ that, by actual analysis, he has detected calaverite, the telluride of gold, in Mohawk ore, and that he believes the greater part of the gold in the low-grade sulphide ore to be present as a telluride. The last statement is disputed by Edgar A. Collins, the former manager of the Combination mine. However, there is no doubt that tellurides exist in the ore, whether in large or small proportion remains to be proved. They constitute part of the metallurgical problem. Neither zinc nor lead minerals are noted. A little chalcopyrite has been seen in the Florence and Sandstorm mines.

The quartz, which is the predominant accessory mineral, is usually flinty in texture. Crystalline cavities are absent, but pockets of alunite are frequent. These explain the difficulty in filtering the pulp after the ore has been crushed, and the necessity for special devices in the mill. The coarseness of some of the gold aggregates explains why amalgamation is needed to supplement cyanidation. The matrix of flinty quartz encasing the finer particles of gold necessitates fine-grinding. The fineness of much of the gold justifies the use of a solvent, such as cyanide, after amalgamation. Whether roasting and dry-crushing are better than milling raw ore is a disputed question, with the preponderance of opinion in favor of the latter practice.

The Combination mill has been described in this journal by Mr. Bosqui, so it is not necessary to repeat. The same description appears in the volume entitled 'Recent Cyanide Practice.' When I

³ I am informed later by C. D. Wilkinson that the above description is true of the Florence and Combination ores. In the Mohawk and Red Top the needle-shaped crystals do not appear and neither does the tetrahedrite. The occurrence of calaverite is still a question, as Mr. King made his determination by the ratio of gold and tellurium only; the higher-grade ore contains free gold, which will destroy this ratio.

⁴ 'Cyanidation in Nevada.' Lochiel M. King. *Mining and Scientific Press*, January 25, 1908.

went through the mill, on April 10, I noticed a broad streak of fine gold, like a band of paint, at the head of the Deister concentrating table, which receives the re-ground product from the tube-mill. This testifies to the advisability of using amalgamation. At the time of my visit the amalgamating plates in front of the stamp-batteries were blinded or covered with old vanner belts. (This was being done experimentally. In the new mill there will be thorough amalgamation before and after tube-milling.) From the battery the ore went to classifiers, the coarse passing to the tube-mill, while the fine was washed over supplementary amalgamating plates; both products went to the concentrators, one Deister and six vanners. The Deister table received the classified product, all finer than 200-mesh, from the cone-classifiers. From the vanners the pulp went to the cyanide annex. That band of gold on the concentrating table spoke eloquently for the usefulness of amalgamation. If you can save the gold at the very start, within or just outside the stamp-battery, why not do so? The metallurgist who pins his faith wholly on his cyanide annex is like the sportsman who does not mind missing with his right barrel, expecting to hit his bird with the left barrel, which is choke-bore and reaches farther. He wastes ammunition and is apt to miss his bird after all, for the farther it flies from him the more difficult it is to hit.

After the Combination mill came that of the Nevada Gold Reduction Co. This plant includes a sampler, with a capacity of 450 tons per diem, and a cyanide mill, treating 100 tons per diem. The surplus ore is sold to the smelting companies. The equipment of the mill includes 20 stamps, of 1250 lb. each, by which the ore is crushed to 12 mesh in a 0.50 to 1.25 lb. KCy solution. The pulp on issuing from the mortar goes over amalgamating plates and then to 8 Wilfley concentrators, classifying into three products, namely, concentrate, sand, and slime. The concentrate assays from \$200 to \$1000 per ton and is shipped to the smelters; the sand goes first to an Allis-Chalmers tube-mill, 5 by 22 ft., reducing it to a screen-size of less than 100 apertures per linear inch; from the tube the re-ground product passes over supplementary amalgamating plates and then to classifiers, the oversize from which is re-ground after going over a Wilfley. The leaching plant, which receives the pulp after the free gold and rich sulphides have been partly extracted by concentrators, includes eight vats of 22 by 5 ft. and three agitator-vats of 24 by 16 ft. Three vacuum-filters of the Butters type strain the gold-bearing solution, which is further clarified by passage through a 5-ton American filter-press, remodeled by E. S. Leaver, the superintendent of the mill.

Next in point of time, and a neighbor of the Nevada Gold Reduction Co.'s mill, is the Goldfield Cl Mill Co. This company has adopted the symbol of the chemical element chlorine as part of its corporate name. The plant is not yet in regular operation, although a trial run has been made. It is a most interesting departure and is due to the initiative of John E. Greenawalt, well known in Colorado as a chlorination expert.

The roasting furnace is a rabble roaster of the muffle type; it has a porous hearth and is heated with producer-gas manufactured from coal (coming from Helper, in Utah) enriched with crude oil (from Bakersfield, California). From this furnace the roasted ore goes to a cooling-cylinder, at the end of which it is moistened before delivery into a bin. From the bin it is transferred to large vats by means of a grab-bucket of 60 cu. ft. (nearly 3 tons) capacity, operated by a traveling electric crane. The chlorination vats are of wood, sealed by a wooden cover dipping into a launder filled with water. When silver ore is being treated 2% salt is added, before crushing, so as to get a good mixture. The leaching in the vats is done by a strong solution of chlorine in water—7 to 8 lb. free chlorine per ton of solution. Leaching requires 3 to 4 days. The seven vats are each 22 ft. diam. and 8 ft. deep. The gold solution is withdrawn by gravity and pumped into a storage-vat and thence drawn to the precipitating-boxes, resembling the zinc-box of a cyanide plant. The precipitation of the gold is effected electrolytically, the anode being graphitized carbon and the cathode lead-shaving containing 1% zinc, the presence of the zinc hastening the corrosive action. The slime of lead, gold, and silver while still moist is mixed with flux and briquetted. The briquettes are melted in a reverberatory furnace and then refined in a cupel.

The chlorine is generated electrolytically. At first salt was obtained from Hazen, in Nevada, but it was found to contain over 5% silica, from sand blown across the dry lake; the salt now used comes from Salt Lake and costs \$16.25 delivered. The solution of chlorine water is made in an absorbing tower; this consists of two sheet-iron stacks lined with glazed sewer-pipe, with cement between the pipe and the outer iron. Inside is placed a filling of hollow clay balls, each of them having eight perforations. The chlorine gas is introduced at the bottom of the stacks and water is made to trickle down from the top, the large surface thus offered facilitating absorption.

The mill has a nominal capacity of 100 tons per diem. The ore is crushed to 14 mesh and the roaster is 100 ft. long. A peculiar feature of the plant is the use of piping made of hard rubber; the pumps are actually made of it and look like cast iron until one is informed of their true composition; then they look like chocolate. Of course, iron and brass would be attacked by the hydrochloric acid, hence the use of wood in the vats and rubber in the pumps and pipes. This mill was not ready to receive custom ore at the time of my visit (in April), and yet I stated, in the opening paragraph of this article, that chlorination had been applied successfully at Goldfield. A metallurgical process is applied successfully when it yields a profit to the operator. I was referring to the use of chlorination in treating 'high-grade,' that is, stolen ore. For this purpose it is convenient, and although the percentage of extraction is not anything like that to be made by Mr. Greenawalt, it is adequate for the purposes of a 'fence,' where only 50% of the value of the gold in the stolen ore is received by the thief.

Mr. Greenawalt is an enthusiastic chlorinator and deserves suc-

cess. His mill should afford a market for the rich concentrate obtained as a by-product in the cyanide plants. Mr. Greenawalt keeps some gold leaf on hand and performs a simple experiment to illustrate the greater efficiency of chlorine as a solvent compared to cyanide. In one beaker he placed a 5-lb. or 0.25% cyanide solution and in the other a 7 to 8-lb. or 0.33% chlorine solution. Dropping a fragment of leaf gold into both of these solutions, it was seen that the chlorine dissolved the metal instantly, while the cyanide had not completely eaten up the gold in an hour, a few particles of gold remaining at the bottom of the beaker, where oxygen was not available. It may be proper to point out that gold leaf does not exactly simulate the condition of gold in ore; further, cyanidation may be possible without previous roasting, but chlorination is rarely successful on raw ores. In cyanidation, the rate of solution decreases rapidly as the particles of gold increase in size, and in this respect chlorine is a more energetic solvent.

On the northwestern slope of Columbia Mtn. the Goldfield Consolidated Mines Co. is building a large stamp-mill and cyanide annex, in which will be made available all the experience obtained in the Combination mill and the other plants treating ores of similar character. At the time of my visit the concrete foundations were being laid at the rate of 100 cubic yards per day, these operations being facilitated by a crushing-plant, the rock used for concrete passing first through a Gates gyratory crusher and then through a Dodge jaw-breaker; then the broken stuff was elevated to a trommel, the oversize going to bins above a concrete-mixer and the undersize to rolls, which reduced it fine enough to make sand. This sand was an angular product well suited for making concrete. The cement comes from Iola, in Kansas. Fully 5000 cu. yd. of concrete will be required. Five thousand barrels of cement have been ordered, at a cost of \$4 per bbl. delivered. A barrel holds 380 lb. On my way to the mill-site I saw a clever device used in grading for a new reservoir, to be connected with the new mill. A piece of sheet iron (an old turn-sheet) $\frac{1}{4}$ in. thick, 5 ft. wide, and 12 ft. long was being used in place of a dump-cart. It was easy to roll rocks upon this piece of sheet iron (avoiding any lifting) and then to drag the load to the dump, where it swung over the edge so as to discharge itself automatically. This reservoir is to be made by using the solid rock for a back wall and half of the sides, simply plastering the surface to make it water-tight. The dimensions are 65 by 150 ft., and 15 ft. high. Steel would have cost \$14,000, wooden tanks \$10,500, concrete construction as outlined above will cost only \$8000.⁵

On arrival at the mill-site, I found a scene of great activity,

⁵ In response to a later inquiry as to the progress of the work, I am informed by J. H. Mackenzie, the general manager for the Goldfield Consolidated Mines Co., that the construction of a concrete reservoir has been abandoned owing to the time required. A water-supply is needed forthwith. So eight tanks made of redwood and 30 ft. diam. with 20-ft. staves will be placed on the reservoir site and two of the same size at the mill. The total capacity will be 1,000,000 gallons.

for the foundations of the ore-bins were being laid, and in the temporary office I met F. L. Bosqui, metallurgical engineer, who worked out the scheme of treatment; G. B. Shipley, the representative of the Allis-Chalmers Co., which has obtained the contract to supply the machinery; and J. B. Fleming, the mechanical engineer for the Goldfield Consolidated Mines Company.

The mill is two miles north of the mines; the ore will be transported over a railroad in 25-ton hopper-bottom cars and delivered into a bin of 850 tons capacity. The mill is expected to treat 600 tons per diem. From the bins the ore passes to a Gates gyratory crusher, which delivers it by elevator to a revolving screen (4 by 14 ft.) having $1\frac{1}{2}$ -in. apertures. The undersize goes to a belt-conveyor; the oversize goes to two Gates crushers and then to the belt-conveyor. This is 26 in. wide; it elevates the final product from the ore-breaker up a slope of 20° and 370 ft. long, through a Blake-Denison weighing-machine, into the sampler. From the sampler the ore is distributed by a belt running over the mill-bins, which have a capacity of 4000 tons. Suspended Challenge feeders deliver the ore into 20 mortars, each containing 5 stamps. The mortars are of the narrow Homestake pattern, but with broad bases and extra heavy, set on concrete blocks. After being crushed under the 1050-lb. stamps the ore passes over amalgamating plates made of silver-plated copper, 5 ft. wide by 16 ft. long. Thence the pulp descends to 20 double-cone classifiers, of 24-in. diam. The overflow passes directly to concentrators while the underflow goes to 6 Dorr classifiers, which thicken the pulp previous to its introduction into tube-mills. There are six tube-mills, each 5 by 22 ft., of the Allis-Chalmers trunnion type, lined with 4-in. siliceous blocks. The product from the tubes is classified in four 48-in. double cones, the overflow from which passes to 14 secondary amalgamating plates, while the underflow is returned to the tube-mills.

The slimed pulp, of which 80% will pass a 200-mesh screen, joins the overflow from the secondary amalgamating plates and proceeds to the concentrators. Concentration will be done in one stage only, namely, after tube-milling. The concentrator used will be either the suspended Frue vanner or the Deister table, and 60 machines will be required. The stream from these vanners will join the overflow from the Dorr classifiers and pass to the settling department. This consists of 16 tanks of 30 ft. diam., 12 ft. deep, provided with 16° cone-bottoms. In these tanks, by means of serial decantation, the pulp will be reduced to a consistence of 50% moisture. Then it will be transferred, partly by gravity and partly with the aid of a large centrifugal pump, into steel agitator-vats operated on the air-lift principle and known as Pachuca tanks. There will be ten of them, 15 ft. diam. and 45 ft. deep. The water overflow from the settlers will be conveyed to a series of clarifying tanks and raised to the mill-reservoir, whence it will be again put into circulation through the mill.

From the Pachuca agitators, where the pulp will be circulated in a cyanide solution for 10 to 18 hours, the material will be trans-

ferred to large reservoirs, in which it will be kept in gentle motion by means of a stirring mechanism, and from these reservoirs it will be drawn by gravity as required into the boxes of the Butters filters. There will be two of these boxes, constructed of steel and with a capacity of 168 filter-leaves. After the deposition of the cake on the frames the surplus pulp will be drawn off by gravity into a large vat on a lower level. Similar vats will be provided for both water and solution, that is, the Butters plant will be operated by gravity throughout.

The solutions from the Butters filters will be clarified in three Perrin filter-presses, each having 50 frames 36 in. square. From these clarifying presses the solution will be drawn to the precipitation vats, where zinc dust will be added in accordance with the Merrill method. The precipitate will be gathered in four 30-frame Merrill presses, and the product melted direct (without acid treatment) in five Faber du Faur tilting furnaces.

The experience of several years in the Combination mill, and special experiments besides, justifies Mr. Bosqui, the consulting metallurgist to the Consolidated company, in expecting an extraction of 95% of the gold, the silver content of the ore being negligible. The total cost of milling is to be under \$2.50 per ton—a low figure, having regard to the high prices of water, power, and labor in this locality.

MILLING AND CYANIDE PRACTICE, SAN PROSPERO MILL, GUANAJUATO

By J. S. BUTLER

(July 25, 1908)

The San Prospero mill belonging to the Mexican Milling & Transportation Co., is situated on the outskirts of the City of Guanajuato, Mexico. The mill was built for the purpose of treating custom ores and has been in operation since November, 1906. During this period it has milled and treated the ores from various deposits within the immediate neighborhood of Guanajuato. The results obtained formed the basis of operation for the San Prospero mill and may be taken as an example of the treatment of silver ore in this part of the country. The mill is constructed on a hillside having an average slope of 24°. The ore after entering the bins at the top of the mill is not again handled by physical labor or returned for treatment in any particular. The motive power is entirely electric, being furnished at 15,000 volts, alternating current, and transformed to 440 volts for the motors.

A 275-ton storage bin, 90 ft. behind the mill proper, feeds by gravity to a No. 3 McCully crusher. This discharges onto a 16-in. Robins belt, which moves across the sample-patio to a cross-belt above the battery ore-bins. These bins have a capacity of 375 tons and are filled by means of a Robins automatic distributor. Each conveyor-belt is operated by a 3-hp. Westinghouse motor, and

the ore is fed to the batteries by Davis automatic feeders. The stamp-mill consists of forty 1050-lb. stamps, dropping 7 in., 102 times per minute. The stamp-guides are of the El Oro solid pattern. The cam-shafts are the Blanton pattern, the bearings being turned to receive the shaft, thus eliminating the necessity for babbitt-metal. The mortars weigh 7500 lb. each, and are anchored to concrete foundations with $1\frac{3}{4}$ -in. anchor-bolts. The battery-timbers are of Oregon pine and are bolted to cast-iron shoes, which in turn are anchored to the mortar blocks. The battery-timbers are also attached to the sills of the ore-bin, allowing the weight of the ore to aid in steadying the battery-frame. Tyler crimped-wire slot-screens are used in the batteries. The stamps are in units of 20, each being driven by a 50-hp. motor. No amalgamation is done, the pulp flowing directly to the concentration plant.

The concentrating plant consists of four classifiers, eight No. 3 Wilfley tables, sixteen cement-tables, and one vanner. The cement-tables were introduced by J. B. Empsom, his idea being to procure a cheap efficient means of separating very fine sulphide, which it was found impossible to detain on the Wilfley tables. These cement-tables are $4\frac{1}{2}$ ft. wide by 27 ft. long, with a pitch of $\frac{1}{8}$ in. per foot. A thin layer of concrete is laid on a wooden platform, and a layer of cement placed above this. The cement is scratched, before setting, to form riffles. This table has proved more satisfactory than canvas, and much cheaper.

The overflow from the cement-tables goes directly to the slime plant, while the sand and concentrate retained are washed into collecting-boxes, and cleaned on the vanner. The sand tailing from the Wilfleys is conducted to the thickening cones at the head of the tube-mill. There are two of these cones 30 in. diam. and 36 in. deep, in which the pulp is thickened to three parts water to two parts sand. The tube-mill is 14 ft. long by 5 ft. diam. It is driven at a speed of 29 revolutions per minute by a 35-hp. motor, lumps of hard ore being used for grinding instead of pebbles. From the tube-mill the pulp flows to the separators 8 ft. diam. by 8 ft. deep, supplemented by four small cones, the underflow going to the sand-collecting vats and the overflow to the slime-plant.

The sand-plant consists of two steel sand collecting-vats 26 ft. diam. by 6 ft. deep, and six leaching vats of the same dimensions. A Blaisdell distributor is used to fill the collecting-vats, the slime being drained off through a central slot-box overflow, and pumped back to the separating cones. A Blaisdell excavator and Robins belt system is used for charging and discharging the sand-vats. In connection with the plant there are two storage-vats of 90 tons capacity each, situated 15 ft. above, for the strong and weak cyanide solutions used in sand treatment.

The slime-plant consists of two steel slime-thickeners 26 ft. diam. by 12 ft. deep, six slime-treatment vats of the same size, three masonry collecting-vats, and the installation of a 60-frame Butters filter for the washing and thickening of slime-pulp.

The slime-thickeners are above the treatment-vats and are dis-

charged by means of goose-necks into a launder running the length of the slime-plant. The pulp in the treatment-vats is agitated by revolving arms through which air is continually blown. The arms are driven by a worm-gear at three revolutions in each two minutes. The pulp is further agitated by 6-in. centrifugal pumps, one being installed for each two vats. The three masonry-vats mentioned above are used to retain slime, wash-water for the press, and to receive the slime left in the press after the cake is made. The weak solution from the vat above the sand-plant is used for slime washes as well as sand-washing after treatment. Above the zinc boxes are two sand-filters for clarifying the weak solution, and a storage vat for strong solution. Each vat feeds to the boxes in the zinc room, the tailing being run to separate storage vats outside. The precipitation boxes each contain five compartments, 36 by 36 by 36 in., with angular bottoms, the screens being 6 in. from the bottom, allowing 30 in. space for zinc. Two-inch underflow valves connecting with a launder carry the precipitate to the sump. From there a Snow pump delivers to a Schrive filter-press above the boxes, so that the drainings flow to the head of the zinc-boxes, avoiding any chance of loss. There are four melting furnaces fitted to receive a No. 300 graphite crucible.

The pump room contains two tailing solution sump-vats, one for strong and one for weak solution, and one mill-supply vat which receives the overflow from the slime-thickeners and as much strong or weak tailing solution as may be necessary. Two Aldrich triplex pumps, 8 by 9 in., deliver from the mill-supply sump-vat to the mill-supply vat at the head of the mill through a 7-in. pipe. The weak solution is returned by a 7 by 9 in. pump and the strong solution by a 5 by 5 in. triplex pump, both in duplicate. Fresh water is pumped from the dam below the mill for use in washing the charges, no water being used for other purposes.

For some months the system of crushing in cyanide solution has been tested, the results proving most satisfactory. The solution in the mill-supply vat, with a capacity of 354 tons, is kept at 0.12% KCy. This solution is used throughout the mill, fresh water being added only for the last washes on the sand and slime. Ore is delivered to the batteries at 1¼-in. size, with 4 gal. of solutions per minute per stamp, and is crushed through 30-mesh with a stamp duty of 3.7 tons per 24 hours. The pulp from each 10 stamps passes to a de-watering cone, the slime flowing to the cement-tables and the sand to two Wilfley concentrators. The Wilfley tables concentrate 230 into 1 with an extraction of approximately 24% of the silver and gold fed to the batteries. The slime tailing flows to the cement-tables and the sand to the thickening cones above the tube-mill. The cement-tables are sluiced down at intervals, the concentrate, containing some sand, being collected and cleaned on a vanner, the tailing being returned to the sand-classifiers. These tables concentrate 2600 into 1 with an approximate extraction of 3% of the precious metal fed to the batteries, the tailing flowing directly to the slime-plant. The sand pulp is thickened to 60%

moisture and re-ground in the tube-mill, and with the overflow passes to the double set of cone-classifiers. The overflow goes to the slime plant and the underflow to the sand-collectors.

The sand after being drained thoroughly in the receivers is charged 'dry,' that is, de-watered, into the treatment-vats. Here 30 washes of strong solution of 0.32% K₂Cy are applied, followed by 20 washes of weak solution of 0.15% K₂Cy and 5 washes of clear water. Each wash of 10 tons of solution requires from 3½ to 4 hours to pass through the charge. The sand is automatically discharged after the last wash.

The sand shows the following on screen analysis:

On	40 mesh	3%	by weight
"	60 "	37	" " "
"	100 "	21	" " "
"	150 "	23	" " "
"	200 "	6	" " "
Through	200 "	10	" " "

Averages on the same charges show that approximately 70% of the extraction is made from the sizes through 40 and on 100

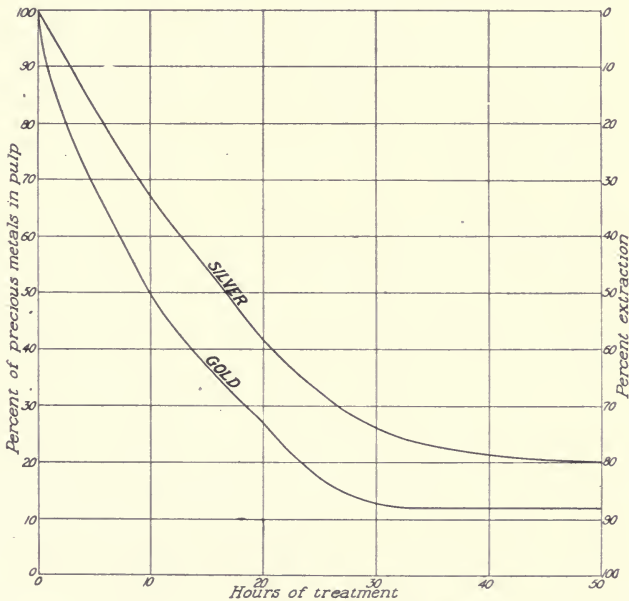

Fig. 34. SOLUBILITY-CURVES. SILME TREATMENT, SAN PROSPERO MILL

mesh, the extraction of the material held on 150 mesh being slightly lower, and of that on 40 mesh, on 200, and through 200 mesh being quite low.

The slime flows to the thickeners above the slime plant and is delivered with 70% moisture through a launder to the treatment

vats. Here the charge of weak solution is brought up to 0.15% KCy_3 , and the agitation continued for 12 hours. The charge is then settled and 30 in. of solution decanted to the sand-filter. This is followed by five washes, the agitation lasting six hours for the first

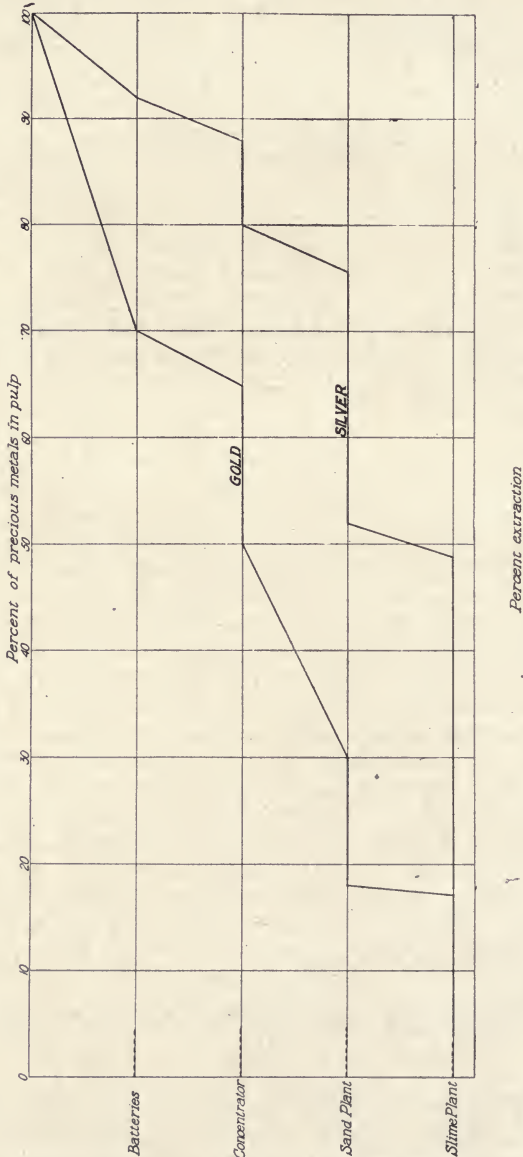

Fig. 35. CURVES SHOWING EXTRACTION DUE TO CRUSHING IN SAN PROSPERO MILL

and four hours for each of the remaining washes. Finally the charge is drawn into the masonry vats, above the Butters filter, with fresh water. The rate of extraction in the slime plant is shown by the accompanying curves plotted from results obtained during two months' run.

The slime-pulp, with the last wash of clear water, is drawn from the masonry vat through the filter-press, the solution flowing to a sump. The cake is formed in 40 minutes, after which time the remaining slime is returned to the masonry vat and the cakes washed with clear water for 30 minutes. The wash-water is returned to the supply tank to be used again, until it contains sufficient metal in solution to be sent to the zinc room. The cakes are finally discharged with fresh water. From 20 to 22 in. vacuum is used on the press, and the cake formed is from 0.6 to 1 in. thick. The filter-leaves are soaked for five hours in a 1 to 1.5% acid bath, before being set. The cycle of operation of the filter for five tons of slime is as follows:

Filling	5	minutes
Making cake.....	40	"
Returning slime	15	"
Filling with water.....	5	"
Washing	30	"
Returning waste water.....	15	"
Discharging	10	"
<hr/>		
Total	2	hours
Thickness of cake	0.6	in.
Tons per charge	5	

The strong solution from the first washes of the sand flows to the supply-vat at the head of the zinc-boxes, while the weak solution from sand, slime, and filter-press is run to a sand-filter on the same level. The zinc-boxes are fed from these supplies, the solutions going through separate boxes and the tailing flowing into the separate vats in the pump room. The flow of the weak solution is regulated to 5 or 6 tons per hour and the strong solution to 2½ tons per hour. Clean-ups are made every 10 days, the zinc-shaving being thoroughly washed and transferred. When all the precipitate is sluiced to the sump it is pumped through the Schrive press, and the cake is thoroughly dried with hot air. It is then fluxed and charged 'loose' into the crucibles.

The sodium cyanide is added in the sump-vats, and the strength of the weak solution and the mill solution regulated by pumping from the common supply. An absolute regulation is obtained by this method. The consumption of cyanide for the past three months has been 0.8 kg. per ton of ore milled, and the zinc used 0.37 kg. per ton. A small amount of lead acetate, 0.07 kg. per ton, is supplied to keep the solution from fouling. A curve is added showing the percentage of extraction throughout the mill, under the new system of crushing in cyanide solution.

By an examination of this sketch, it will be seen that the ex-

traction of metals in the mill before the pulp reaches the cyanide plant is as follows:

	Au %	Ag %
In the batteries	31.2	4.8
Between batteries and concentrators	5.4	5.6
Between concentrators and sand plant	21.0	5.0
	<hr/>	<hr/>
Total mill extraction	57.6	15.4

(August 22, 1908)

The Editor:

Sir—In J. S. Butler's description of cyanide practice at the San Prospero plant, appearing in your issue of July 25, the curve sheets and tables showing the progress of extraction during the milling operation prior to the commencement of the cyanide treatment proper, make an interesting record.

The extraction of the silver and gold content, 4.8% and 31.2%, in the crude ore during the pulping process in the battery is more remarkable when the conditions are analyzed. In a 5-stamp battery of this mill, where the crushing capacity is 3.7 tons per stamp per 24 hr., 28.5 lb. of ore must be fed to each battery per minute, and a like amount (dry weight) of pulp must issue through the battery screens in the same time. As the amount of ore undergoing the pulping process within a 5-stamp mortar will approximate 85 lb., it follows that the average time required for pulping the ore in the mortar would not exceed three minutes. During this time it is known that the size of the ore-pieces found at any time in the mortar will vary from the maximum size, 1½ in., to the portion of slime resulting from the pulping operations, and it is probable that 50% of the 85 lb. of ore always in the mortar-box would be large enough to remain on a ¼-in. mesh screen. What is remarkable is that ore of this disproportion of sizes when submitted to contact with 0.12% KCy solution should yield 31.2% of its gold, and 4.8% of its silver content in three minutes. If the solution of silver and gold in the pulp would proceed at the same rate all the gold in the pulp would be brought into solution in four minutes and the silver in about 60 minutes. This is a more rapid rate of solution than is generally understood to be possible in connection with the cyanidation of ore, and the fact should attract the attention of those crushing ore in cyanide solution and stimulate investigation.

It would be interesting in this connection to know the character of the ore treated, and in what form the silver occurs in it. It is probable that a large portion of the silver exists as a chloride, for silver sulphide would hardly go into solution as rapidly as stated. At any rate, the statement should open up a new line of investigation and research, the results of which cannot fail to benefit the industry.

BERNARD MACDONALD.

Guanajuato, Mexico, August 1.

YELLOW JACKET MILL, COMSTOCK LODGE

By WHITMAN SYMMES

(August 1, 1908)

The Yellow Jacket mine, at Gold Hill, is the first mine on the Comstock Lode to attack the problem of low-grade mining. The mill was completed in February, 1908, and since then has been regularly treating about 180 tons per day. The management is attempting to solve the problem by simple concentration. The men in charge take the view that they can concentrate ore that assays as high as \$8 per ton and leave less than \$2 in the tailing, and they maintain that their \$2 tailing cannot be cyanided at a profit. On the other side of this milling debate is Charles Butters & Co., Ltd., who have 20 stamps, two tube-mills, and a 250-ton cyanide plant in the canyon two miles below Virginia City. In March, 1908, this company obtained leases on the Chollar and Potosí croppings, and has since been doing considerable work in re-opening the two old surface-tunnels and their many drifts. Mr. Butters appears to be preparing to work ore that assays as low as \$7. He must pay 18% of the bullion-value to the lessors, the usual 4% royalty to the proprietors of the Sutro tunnel, and also the local taxes. Therefore he will have to mine, mill, and cyanide for less than \$5 per ton, in order to make a profit on \$7 ore with 90% extraction. His work will be watched with a double interest, for it is understood that he will undertake to reduce expenses by cutting out concentration, with its attendant shipping expenses, as much as possible, and will substitute cyanidation of the sulphides. Low-grade mining opens new possibilities on the Comstock, and there is an immense tonnage awaiting a solution of the problem. The Yellow Jacket mine has a bullion record of \$19,000,000. The lower levels were flooded in 1882, and the mine was then worked in the upper levels for the lower-grade ore which had been passed by in the bonanza days. The water now stands a little below the 1400-ft. level, but the mine is not open below the 1100-ft. level. In 1906 H. L. Slosson and associates bought control of the mine on the Stock Exchange, and took over the management from the Morrow-Sharon interests. The latter gentlemen had previously held undisputed sway in Gold Hill, but they did not own the stock of the mines that they managed. The new owners are now working the low-grade ore in the outcroppings, and are preparing to work the 'gold vein' between the 1100 and 1500-ft. levels, until such time as the water is lowered and access can be had to the deeper workings. Before acquiring control of the mine Mr. Slosson had a verbal option on the Yellow Jacket dump, which was supposed to contain 200,000 tons that would yield a profit of \$1 per ton; but the promotion missed fire. The mill has been placed convenient to the dump, and about 2000 ft. from the hoist; but silver has fallen from 70c. per ounce to 52½c., and the dump is not now so highly cherished.

Formerly Mr. Slosson sold Kinkead mills for Henshaw, Bulkley & Co., of San Francisco, and when he acquired the Yellow Jacket

property he had the courage to swallow his own prescription—the mill he erected has twenty of them. The Kinkead mill at Goldfield has passed to the cemetery; and when Charles Butters & Co. leased the Kinkead mill in Virginia City belonging to the Best & Belcher Co., the operation was said to have been accompanied by costly repairs and extensive profanity. But the inventor seems able to keep his machinery in a better humor. The Kinkead Mining & Milling Co. began operating on the C. & C. dumps in Virginia City, and for several years past has been running without intermission on ore from the Ophir. The new type of crusher in the Yellow Jacket has also run for four months now without trouble. Mr. Kinkead superintends both of these installations. The Kinkead mill consists of a bowl, 40 in. diam., and an inverted mush-room for a muller. The stem is given a small eccentric motion, at 240 revolutions per minute; the ore is fed in through a hole in the centre of the muller, and discharges through screens on the periphery. The total weight on the muller, including the shaft, is about 5000 lb. The original claim for the mill was that it did not slime the ore; but there are considerable quantities of silver sulphide floating on the vanners when working the Ophir \$30 ore.

At the Yellow Jacket the ore from the breaker is ground to 40 mesh in the mills, and is then classified into three parts, in home-made box-classifiers, one for each two mills. The concentrating room has 30 six-foot, plain-belt, Risdon-Johnston concentrators, in three rows, each row taking one size from the classifiers. In April 1908 the mill treated 4632 tons of ore assaying from \$5 to \$7 per ton, and extracted 178,000 lb. of concentrate. The value in the concentrate was 75% gold and 25% silver. The concentration was 52 into 1, and the extraction was about 70%. The tailing assayed from \$1.25 to \$1.86 per ton and the average was close to \$1.75. In May 1908 the mill treated 5472 tons, and all but 750 tons was oxidized ore from the outcrop. One-third the value was silver and two-thirds was gold. The extraction by concentration was 68%. The concentrate generally assayed about \$175, but one shipment went \$579. The expenses of mining and milling were a little less than \$18,000 or \$3.30 per ton. Allowing for smelter deductions, the cost was about \$3.50 for a 68% recovery. The milling and concentrating cost about 75c. per ton, and the cost of shoes and dies, after selling the scrap, was between 12 and 16c. per ton. The cost of marketing the concentrate, including smelter deductions, amounted to 54c. per ton of original ore. The breaker runs two 8-hr. shifts. The mill runs three shifts, with two men at a time at the mills and two at the concentrators. Mill foremen work one shift only. The mill and rock breaker averaged, by meter, 115 hp. for the month, at a cost of \$5 per hp.-month. The mill cost when completed \$82,000, of which \$8000 was expended for excavation.

There are three classes of ore in the mine, and unfortunately they are not equally susceptible to concentration. The sulphide-silver ores yield about 70%. The oxidized outcrop yields between 60 and 70%, and only 50% of the silver content is extracted. The

'gold vein' on the foot-wall has practically no silver, and yields by concentration fully 80% and sometimes as high as 88. Each month the drop-boxes below the Kinkead mills are cleaned out and the sand is panned with quicksilver. About \$1200 is thus obtained, which is nearly all gold. If the simple concentration-process adopted by the Yellow Jacket has any advantage, it is evident that it can hold that advantage only below a certain limit, which is determined by the cost of cyaniding. The Kinkead Mining & Milling Co., at Virginia City, is working \$30 ore from the Ophir, using Frue van-ners, without classification, and also a small canvas plant. The concentration is 33 into 1, and the extraction by concentration for six months has averaged about 71% on the mine-car samples, and 75% on the mill-pulp assays. The gold extraction was 84% and the silver 59, based on battery assays. The tailing assayed from \$5 to \$8 and was sold to the cyanide plant of Charles Butters & Co. The Yellow Jacket has not given the final solution of the problem of working the immense quantities of low-grade ore in the Comstock veins, but it is the first mine on the Lode to mine and mill its ore at as low a figure as \$3.50 per ton.

CYANIDATION IN MEXICO

By FRANCIS J. HOBSON

(August 1 and 8, 1908)

In the early part of 1906 I made a number of laboratory experiments on silver-gold ores from the State of Sinaloa, Mexico. The results of these experiments demonstrated that silver could be successfully extracted from its ores by the use of a comparatively large amount of strong cyanide solution. A small leaching plant was erected, using filter-vats each having 10 tons capacity. The ore used in the experiments contained 15 oz. silver and 0.15 oz. gold. In order to secure an even leach it was found necessary to remove some 15% of its weight of slime, containing approximately 20% of the assay-value. The ore was crushed to pass 40 mesh. A 10-day leach, with 0.5% KCy solution, extracted 84% of the silver and practically all of the gold. The weight of solution used, in proportion to the weight of ore, was three of solution to one of ore. The strength of the solution was kept up to 0.5% for the entire period, and the cyanide consumption was about 3 lb. per ton. Ten pounds of the local slaked lime was intimately mixed with the charge before starting the leach. The gold and silver was precipitated from the solutions on zinc shaving. The separated slime was treated in the laboratory with various strengths and amounts of solution, resulting in a high extraction of the silver, when using four, or more, times the weight of dry slime of 0.2% KCy solution. The silver in the ore was nearly all argentite. The gangue contained 90% silica, about 2% iron pyrite, 0.5% hematite, traces of manganese as pyrolusite, 0.5% aluminum, 3% lime as carbonate, and no copper. As silver had not before been cyanided with any

degree of success, I considered this application new, and almost equivalent to the invention of a new process. I am still under the same impression, and believe that successful cyanidation of silver ores in Mexico began with the installation of that small leaching plant. It was operated for several months, and several clean-ups were made, which checked closely with the estimates from assays. The precipitate was melted in a crucible, and a bar of bullion produced assaying 830 points fine silver and 10 points gold.

At that time I was in charge of a mill and pan-amalgamation plant that was extracting about 80% of the silver and 70% of the gold content, and ahead of the treatment we were losing about 10% in slime. I tried to persuade the company to change to the cyanide process, but they were afraid to make the experiment, regardless of the fact that I had proved by bullion-returns that it was good business to do so. The importance of the tests lay in the discovery that silver could be successfully extracted from its ores by the cyanide process (in the absence of base-metal interferences in the gangue) if ground sufficiently fine, by subjecting the sand to a leach, wherein the silver was brought in contact with 30 times its weight of potassium cyanide, and that silver could be extracted from the slime if the latter was agitated with 16 times its weight of potassium cyanide. In either case the strength of solution did not appear to be an important factor. To date I find this to be invariably the rule, except where the silver occurs as chloride or bromide. In that case the proportionate requirement of cyanogen is much less.

In the year 1898, I installed a plant of 1000 tons per month capacity in the State of Durango, converting it from a roasting-hyposulphite-lixiviation plant. The ore was dry-crushed to pass 16 mesh, and leached in vats having capacities for one hundred 40-ton charges. The extraction was 77%, the resulting bullion being 940 fine silver, and 18 points gold. Finer grinding would not permit an even leach, consequently the low extraction, which was about equal on both gold and silver. In January 1899 I began building a slime-agitation plant in Durango, and had it operating in May of the same year. Here I had my first opportunity of practically demonstrating my 16 to 1 theory for silver extraction by agitation. The slime treated contained from 14 to 25 oz. silver per ton, and the plant-capacity was 7 tons daily. The charges, of about 2300 lb., were agitated four hours with four times their weight of 0.2 to 0.3% KCy solution, and 12 lb. slaked lime, and were then drawn into settling vats. After settling, the solution above the charge was decanted into a clarifying tank, and another full charge of solution was added to the slime-charge under treatment. After its decantation, about 2500 lb. of wash-water was added, and this was decanted after settling. The decanted solutions were passed through zinc-boxes and returned to the upper sump-vat for re-use. Before treating, the slime was collected in settling-vats, from which it was removed to a large patio (yard) and sun-dried. This drying made the water-wash possible, reducing the mechanical loss of cyanide

in the discharged residues. The chemical extraction in the agitation-period averaged about 92% ; 80% of the extraction was recovered by the first decantation, 80% of the remaining twenty by the second, and 50% of the remaining four by the water-wash decantation, resulting in 98% recovery of the chemical extraction or silver in solution. The plant is still in operation, and the extraction by bullion-returns since the installation of the plant has been the same, 90 per cent.

In the latter part of the same year (1899) E. A. H. Tays installed a successful plant for slime treatment at San José de Gracia, in the State of Sinaloa. In the early part of 1907 I tested ores and designed a plant, for another Durango company, that was installed and is still in very successful operation. A variation here from my previous practice was that of concentrating ahead of cyaniding. After concentration, the sand and slime are separated, the sand being leached, and the slime agitated with cyanide solution. About that time, Messrs. Corrigan and McKinney erected a 40-stamp mill with a cyanide annex at Concheño, Chihuahua. Concentration preceded cyaniding, and the sand and slime were treated separately. Difficulties were encountered in settling the slime, and solution is recovered from the treated residue by a special filter-press designed by Mr. Corrigan. In 1898 one plant in the Territory of Tepic, and another in the State of Michoacán, substituted cyanide solutions and zinc precipitation for hyposulphite lixiviation on chloridized roasted ores. The Michoacán treatment was changed under my direction in 1901 to amalgamation, concentrating, and cyaniding the raw sand and slime separately. The change resulted in a slightly higher extraction, and a decrease in treatment-cost of \$5 per ton.

In 1901 a 2000-ton per month plant was installed in the Territory of Tepic, under my supervision. The ore is crushed in Bryan mills, concentrated on Wilfley tables, the sand leached and the slime agitated with cyanide solution. The silver recovery averages 88 per cent.

During the years 1900-01-02-03, several small plants were installed in the Republic by myself and others for treating silver and silver-gold ores. The majority of these installations are commercial and technical successes. The ore treated with cyanide daily in Mexico was, at the end of 1903, about 500 tons. This refers only to those plants treating ores where the silver predominates over the gold content, in value. The most important application of the process since 1903 has been in the district of Guanajuato, where about 2500 tons of ore are being treated daily. This will be increased within eighteen months to 6000 tons, the installations now being under way. There are 10 mills in operation, with capacities varying from 1000 to 1500 tons per month, most of them of my own design. The general practice in the camp is to crush, concentrate, and cyanide the sand and slime separately. Three of the mills, however, amalgamate the gold before concentration. The average total silver saving of all the plants is near 90 per cent.

During the period 1903-1907 a number of important plants were installed in the Republic. The Charles Butters Co. is successfully operating a large plant near Panuco, Sinaloa; the Palme-rejo Co., one in Chihuahua; the Real del Monte Co., a large plant in Hidalgo, and a number of other plants, of more or less importance, are operating in the States of Chihuahua, Jalisco, Durango, Sinaloa, Zacatecas, and Querétaro. Also a number of others are in the course of construction, the total tonnage now treated daily in the Republic being about five thousand. The adoption of the process has created a new industry in Mexico, as 90% of the ore treated by it could not be reduced profitably by any other known process. It has almost entirely superseded the patio and pan-amalgamation methods. Invariably a larger percentage of silver in the Mexican ores can be extracted by cyaniding, at from one-fourth to one-tenth the cost of amalgamation. This may seem like a broad statement, but it is nevertheless true. The average cost per ton of cyaniding crushed ore in the Guanajuato district is about \$1.25, and in some of the larger plants it is less than 75 cents.

In considering the adaptability of the cyanide process for the extraction of silver from its ores, the question arises as to the solubility of the various natural occurrences of the metal, and the physical and chemical characteristics of the material to be treated. The chief silver minerals are: the native metal and the sulphide argentite; three species among the sulpho-arsenites and sulpho-antimonites, namely, proustite, or ruby silver; pyrargyrite, or dark-red silver; and stephanite, or brittle silver; the bromide and chloro-bromide, bromyrite and embolite; argentiferous tetrahedrite, containing sometimes as high as 30% silver as argentite; argentiferous galena, and blende containing silver as sulphide. The native silver is so slowly soluble in cyanide that practically no extraction from it can be obtained. Argentite is readily soluble, as likewise the chloride, the bromide, and the chloro-bromide. Proustite, pyrargyrite, and stephanite are sparingly soluble in cyanide solution, but are readily soluble in a solution of mercurous potassic cyanide. The extraction of silver by cyanide from argentiferous galena, tetrahedrite, and blende is a problem yet to be solved. Taking these facts as a basis, in the absence of irremovable chemical interferences caused by the presence of base-metal compounds in the gangue, silver can be extracted from ores where it exists in soluble form, if the physical structure permit of solution-contact with the contained argentiferous compound. The application of the process then resolves itself into:

- (1) Grinding to the necessary fineness for solution-contact; maintaining the strength and quantity of solution necessary; and giving a preliminary treatment or in adding chemicals other than cyanide to the mill solution.

- (2) The advisability of classification of the milled ore into concentrate, sand, and slime, or into sand and slime before cyaniding.

In the case of gold-silver ores it is often advisable and sometimes necessary to amalgamate the coarse gold before concentrating

or cyaniding. The most obstructive chemical interference is due to the presence of oxide or carbonate of copper. It is claimed, and in one or two cases has been proved, that cuprous ammonium cyanide as a solvent has overcome this interference in the case of gold ores, but as yet this remedy has not been demonstrated in silver practice. Preliminary treatment with sulphuric acid for the removal of the copper salts has been successfully applied. I am of the opinion that the combination of the two remedies will solve most problems arising from copper interference.

The one other important interfering base-metal salt, namely, ferrous iron (when existing in a form not removable by preliminary treatment), is readily overcome in mill-solution by adding mercurous chloride. Ferric salts and ferrous sulphate interferences are readily overcome by preliminary treatment with lime. Manganese salts, when occurring in sufficient quantities to cause trouble (provided they do not exceed 3 or 4% Mn), can be precipitated during the process of treatment by adding to the solution an excess of calcium hydrate. Aluminum interferences are controlled by adding calcium hydrate in excess. Soluble sulphides formed during treatment are neutralized by the use of lead acetate. In Mexican ores, we have not yet encountered base-metal salts, other than those mentioned, in sufficient quantity to cause trouble.

After it is determined that an ore is amenable to the process, the details of application become a mechanical and economical problem. In cyaniding concentrate, much stronger solutions or a much longer time of contact, is necessary than for treating sand, and for sand-treatment a longer time or stronger solution may be necessary than for the treatment of slime. Consequently few cases are conceivable where it is not advisable to make this classification before cyaniding. The prevention of a large mechanical loss of cyanide causes the use of a large bulk of weak solution in slime treatment. It is obvious that slime residue will be discharged with the same moisture, the contained solution being 0.01% KCy. Every ore is a problem in itself, and the adaptability of the process for it, can only be determined by a careful chemical and physical investigation. Many failures have been caused by merely imitating a neighbor's process and design of plant.

The chemical reactions on which the cyanide process rests for the extraction of silver from its ores, all lead to the formation of the double salt of cyanide of silver and potassium, $KAgCy_2$. The well known and accepted Elsner equation:

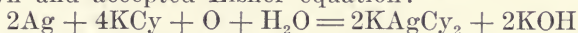

can only apply to the solution of metallic silver. In dissolving argentite, Ag_2S , the most common occurrence of soluble silver, I am of the opinion that the following reaction takes place:

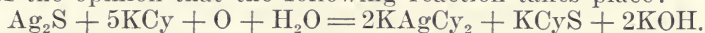

This belief is substantiated by the fact that potassium thiocyanate, $KCyS$, is always found in mill-solution. I am of the opinion that soluble sulphides (also always present) are formed by the combination of free hydro-sulphuric acid, H_2S , with the free or liberated

alkaline hydrates, and by the action of alkaline hydrates on base-metal sulphides. In most cases the H_2S has been formed in the ore-charges before being brought in contact with the solutions.

Mine water is often necessarily utilized for milling purposes. It generally contains some free hydro-sulphuric acid. The gas from this source, as well as that generated in the ore-charges by the action of free sulphuric acid on the base-metal sulphides, combines with the free cyanide of potassium and the free alkaline hydrates to form both thiocyanate and sulphide of potassium. When zinc is used as a precipitant, soluble sulphides are mostly removed from solution by precipitating zinc sulphide, ZnS , and re-generating cyanide of potassium:

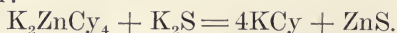

Any excess can be removed by the addition of lead acetate:

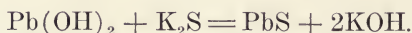
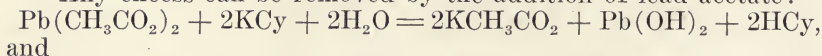

The precipitated sulphides are discharged with treated residues. Some silver is always precipitated in the zinc-boxes as sulphide, at times enough to cause trouble in melting the precipitate. Mercurous potassic cyanide, $KHgCy_2$, dissolves silver sulphide as follows:

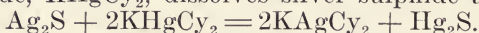

The salt is very unstable, and must be protected in solution in its mercurous state by the presence of some reducing agent, such as ferrocyanide of potassium. The latter salt is generally present in mill-solution, and consequently need not be added in practice. Mercurous potassic cyanide, in the presence of free alkaline hydrates, also readily dissolves stephanite, Ag_5S_4Sb , pyrargyrite, Ag_3S_3Sb , and proustite, Ag_3S_3As . I am of the opinion that the reactions taking place in this solution are as illustrated by the following equations:

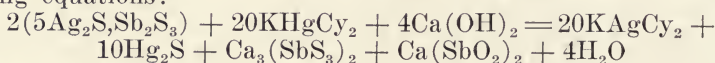

and

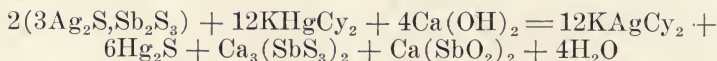

and

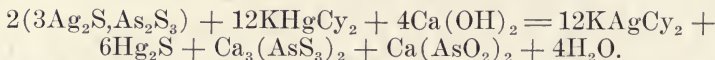

The formation of the salt $KHgCy_2$ in practice is best made by adding calomel, Hg_2Cl_2 , to the cyanide solution:

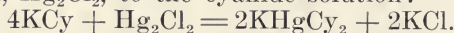

In the absence of free ferrocyanide of potassium, or other reducing agent, mercuric potassic cyanide is formed and metallic mercury precipitated:



In ordinary practice the ore is first subjected to treatment with solutions of potassium or sodium cyanide until all or about all of the possible extraction has been obtained; then mercurous chloride is added and the treatment continued to the end. The only serious

interferences I have encountered in the use of mercurous potassium cyanide are manganic compounds. They immediately oxidize it to a mercuric salt, destroying its usefulness as a solvent. The salt does not dissolve gold. Its use is covered by letters patent in the United States and foreign countries.

When there is enough ferrous iron in the ore to cause a serious interference, the salt is best formed by adding mercuric chloride to the mill-solution:

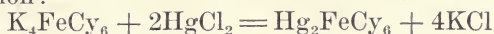

and

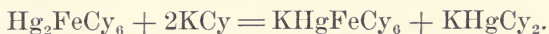

The addition of the mercuric salt serves the double purpose of converting the interfering ferrous salt to non-interfering ferric salt, and the generation of the solvent $KHgCy_2$.

An investigation of a case of solution fouled by ferrous iron led to the discovery of mercurous potassic cyanide as a silver solvent. The ore in question contained from 2 to 3% ferrous oxide, an interference that could not be removed by preliminary alkaline washes. New solutions on this ore yielded 80% extraction of the silver. The second use of the solution gave 65% extraction, a third 50%, and a fourth 30%. Further use of the solution continued to give this latter extraction. The solution became heavily charged with ferrocyanides of potassium, zinc, cadmium, and other metals which coated the zinc in the boxes and prevented precipitation. Mercuric chloride was added to the mill-solution, as an experiment, with the idea of changing the ferrocyanide to a ferric salt. The remedy was a success, and the silver extraction was raised to 92%, creating the belief that a more active silver solvent than cyanide of potassium had been formed. Careful laboratory investigation confirmed the belief that the more active solvent was mercurous potassic cyanide.

Prominent features demonstrated by further tests on ore containing silver as argentite, proustite, and pyrargyrite, were as follows:

(1) The chemical equivalents in solution necessary for the reaction

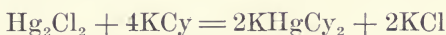

sufficient to make a 0.5% solution $KHgCy_2$ applied to silver-gold ore, plus 0.5% slaked lime, gave practically no silver extraction, and 30% gold extraction, demonstrating the necessity of ferrocyanide of potassium or some other reducing agent to prevent the formation of mercuric cyanide and the precipitation of metallic mercury. The gold extracted was probably dissolved by the mercuric potassic cyanide formed.

(2) The same mixture, with 0.2% free K_4FeCy_6 in solution, gave 86% silver and no gold extraction, proving the efficiency of a protective reducing agent, and that $KHgCy_2$ is not a solvent for gold.

(3) A mixture in solution of K_4FeCy_6 and $HgCl_2$, sufficient to make 0.3% $KHgCy_2$ by the equation already given, plus 0.2% free

K_4FeCy_6 , plus 0.2% KCy, gave 85% silver extraction and 80% gold extraction, proving that free KCy is necessary for dissolving gold, and strengthening the belief that the reactions previously given for solution of antimonial and of arsenical silver are correct, and proving also that the presence of ferrocyanide of potassium retards the solution of gold. For this reason, in practice ores are first subjected to treatment with plain KCy solution.

(4) A 0.5% KCy solution applied to the same ore gave 51% silver extraction and 90% gold extraction, proving that arsenical and antimonial silver ores are but slowly, if at all, dissolved by cyanide of potassium, and that a solvent for these is formed by adding mercurous chloride to potassium cyanide solution in the presence of free ferrocyanide of potassium.

(5) A 0.2% KCy solution gave 32% silver and 90% gold extraction.

(6) A mixture of K_4FeCy_6 with either $HgCl_2$ or Hg_2Cl_2 did not make a silver solvent, negatively showing the probability of the correctness of the reactions given for the formation of mercurous potassic cyanide, when adding mercuric chloride to a solution of cyanide and ferrocyanide of potassium.

(7) Experiments, conditions being same as in third test except that no lime was added, on pulp which had been thoroughly washed with distilled water, gave 43% silver and 90% gold extraction, corroborating belief in the correctness of the reactions given for the solution of arsenical and antimonial silver.

The time of treatment, quantity of solution, and amount of lime, $Ca(OH)_2$, added in each experiment was the same. The tests were repeated several times, and the results given are the averages of all the experiments. The use of mercurous potassic cyanide at the Peregrina 440-ton plant increases the silver extraction approximately 15%. Commercially, the return is \$1 for 12 cents.

A careful study of the various base-metal and cyanogen compounds in mill solutions will enable the chemist to improve extractions and to lower the cost of treatment. Almost invariably the double salts of cyanide of potassium, sodium, and calcium, with zinc, ferric and ferrous iron, are present; and generally the salts of aluminum, magnesium, manganese, and of other base-metals. Ferrous iron combines with cyanide of potassium to form ferrocyanide of potassium, and this forms, with the soluble salts of aluminum, cadmium, zinc, calcium, and ferrous iron, white precipitates, $Al_2(OH)_2$, Cd_2FeCy_6 , Zn_2FeCy_6 , $K_2CaFeCy_6$, and $K_2Fe_2Cy_6$, all of which pass the filter-cloths, or are decanted with the solutions, and collect in the zinc-boxes, coat the shavings, and prevent precipitation. As before mentioned, mercuric chloride added to mill-solutions changes interfering ferrous to a non-interfering ferric salt, and prevents the formation of aluminum hydrate, ferro-cyanide of zinc, cadmium, calcium, iron, and so forth.

A number of methods for determining ferro-cyanide of potassium in solution are given in the text-books, but I have found none of them accurate. The following method has given good results

in practice: to an aliquot part of the solution is added just enough silver nitrate to neutralize the free cyanide of potassium, then mercuric chloride is added to excess, and the iron is determined in the well-washed precipitate. This is done by bringing the precipitate into solution with aqua regia, boiling off the nitric acid, and removing the mercury from solution with H_2S . After the removal of the excess of H_2S , nitric acid is added to the solution and the iron is precipitated with ammonia. The process is somewhat tedious but accurate.

In practice, mercuric chloride is added to the solution in the proportion of eight to one of ferrous iron as Fe when it is necessary to transmute all ferro-cyanide present. Mercuric chloride does not precipitate ferric iron. Aluminum and magnesium salts react as acids, precipitating their hydroxides, Al_2O_3 and MgO , in the presence of free calcium hydrate, cyanide of calcium being formed:

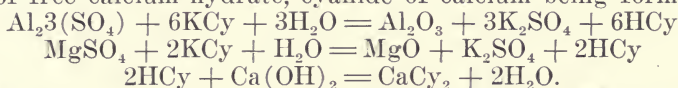

Manganous salts precipitate manganese cyanide, MnCy_2 , which forms with cyanide of potassium the double salt K_2MnCy_4 , decomposed by calcium hydrate, precipitating the hydroxide $\text{Mn}(\text{OH})_2$:

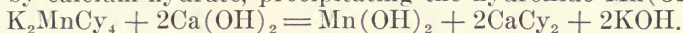

Ferrocyanide of potassium precipitates a white ferrocyanide of manganese which acts similarly to the ferrocyanides before mentioned. The double salt of potassium and manganese is also changed in solution to manganicyanide, with oxidation of a portion of the manganese:

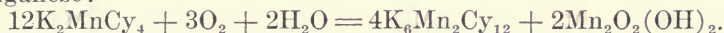

Ferri-cyanides precipitate manganous ferri-cyanide, $\text{Mn}_3\text{Fe}_2\text{Cy}_{12}$. Where silver occurs in any of the forms soluble in cyanide of potassium, calcium hydrate added to excess efficiently overcomes the interference. In the absence of an excess of calcium hydrate, a number of manganese compounds are formed, which obstruct the solution-conduits with complex many-colored manganese precipitates, and at times form manganate and permanganate sufficient to color the mill-solutions. Manganic salts rapidly oxidize mercurous potassium cyanide to a mercuric condition, destroying its usefulness as a solvent; consequently it cannot be utilized on ores containing any appreciable amount of manganese.

The only reliable test for available cyanide in the mill-solution is titration with nitrate of silver without the use of the iodide indicator.

A very good method for determining gold and silver in solution is precipitation with cuprous chloride. To an aliquot part of solution is added an excess of cupric sulphate and then hydrochloric acid. After one or two minutes agitation the precipitate is collected on a filter paper, and is run in a crucible for gold and silver in the usual manner. This method was suggested by S. B. Christy, of the University of California, in an article read before the American Institute of Mining Engineers, Vol. 26, 1896. It was after-

ward published, I think in 1901, by Walter H. Virgoe in a paper read before the Institute of Mining and Metallurgy of London. The method is practically accurate for both gold and silver without the addition of sodium sulphite. A modification of the method is precipitation by adding excess of saturated solution of copper sulphate plus 5% free sulphuric acid. This gives practically perfect precipitation of both gold and silver. Freshly precipitated copper sulphide added to an acidified cyanide solution precipitates both gold and silver completely if the solution does not contain more than 0.1% hydrocyanic acid. The advantage of any of the three methods given is that they may be applied to a large bulk of solution, and the whole operation completed within one hour. An excess of any of the alkaline sulphides completely precipitates silver from the cyanide solution.

The chemistry of the zinc-box is only interesting when mill-solution is allowed to foul, a condition incompatible with successful cyaniding. With comparatively clean solution, no troubles are encountered in precipitating silver, except from those containing an appreciable amount of copper. In that case it is advisable to precipitate the copper on a heavy zinc-lead couple (in separate boxes) before precipitating the silver.

CYANIDATION IN MEXICO

(August 29, 1908)

The Editor:

Sir—I have read with much interest the article by F. J. Hobson on 'Cyanidation in Mexico,' which appeared in your issues of August 1 and 8. The extraction of silver from sulphide ore is of special interest to me, as I believe I was the first cyanide chemist sent into Mexico. In 1891 the Mexican Syndicate sent W. H. Trewartha James and myself to Mexico to investigate the field for cyanide work. I had a portable assay-outfit and testing-plant, and did a good deal of work on ores from various parts of the Republic. At that time practically nothing was known as to the treatment of silver ores, and I had no data to guide me. I found that by using a sufficiently strong cyanide solution I got a good extraction on ores containing argentite, and that by using an oxidizing agent with the cyanide, in many cases a very high extraction was obtained. On ores containing antimonious and arsenical minerals the extraction was never good. Owing to ill health I left Mexico in 1892, and did not subsequently have any opportunity of continuing the work on silver-ore treatment. The prospectus of The Mexican Gold & Silver Recovery Co., Ltd., contained my report on the treatment of Mexican ores, in which special stress was laid on the suitability of silver ores to cyanidation, while comparatively little reference was made to gold ores. The company was floated late in 1892 or early in 1893, but it is only during the last few years that the cyanidation of silver ores has received attention.

The extraction of silver from its antimonious and arsenical sulphide minerals without previous roasting was a difficult problem, and by solving it, Mr. Hobson may claim to have introduced what is practically a new process. In explaining the reactions that take place in the solution of these silver compounds in cyanide in the presence of compounds of mercury, the Mexican metallurgists do not agree with the standard chemical authorities. According to Roscoe and Schorlemmer's 'Treatise on Chemistry,' Vol. 2, page 521, "mercurous sulphide does not exist." Then either Mr. Hobson's equation showing the solution of silver sulphide in his hypothetical mercurous potassic cyanide is incorrect, or the authorities are. Mercuric cyanide is soluble in water, and in this respect differs from the cyanides of the other heavy metals. It is, therefore, not necessary to consider that when a mercuric salt reacts with potassic cyanide, a double cyanide is formed. It can, in fact, be demonstrated that, if potassic cyanide and calomel be made to react according to the equation quoted by Mr. Hobson,



in presence of oxygen, the reaction proceeds further until all the cyanogen is combined with mercury;

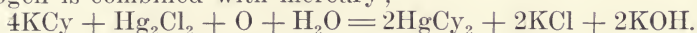

The authorities state also that mercurous cyanide does not exist. The decomposition of ferrocyanide by mercuric oxide, or a mercuric salt, is well known as yielding all the cyanogen as mercuric cyanide. Mr. Hobson's discovery that the silver-bearing antimonious and arsenical minerals, stephanite, pyrargyrite, and proustite, are soluble in cyanide solution containing a compound of mercury, and an excess of alkaline hydrate, is of great interest, and will prove of great value in the treatment of these important silver minerals. It is not possible, however, for calcic thio-antimonite, which consists simply of a solution of antimonious sulphide in calcic sulphide, to exist in solution with silver cyanide. The silver would be precipitated as sulphide. I would suggest that the reaction may go along the following lines: the first step in the reaction or series of reactions may be taken as represented by the equation given by Mr. Hobson as to the reaction with stephanite, but I would prefer to state it thus:

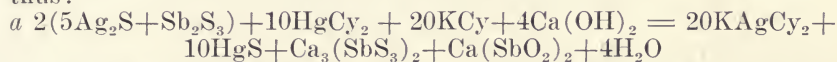

It is well known that antimonious sulphide is soluble in alkaline or alkaline-earth hydrate solution forming a soluble thio-antimonite and an antimonite, as given in the equation by Mr. Hobson. In the presence, however, of a compound of a metal, the sulphide of which is insoluble in cyanide solution, for example, lead or mercury, the thio-antimonite is decomposed. The reaction may be stated thus:



The antimonious sulphide then reacts with some more of the calcic hydrate, again forming thio-antimonite and antimonite, thus:

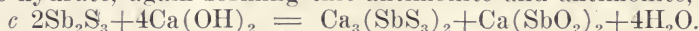

The thio-antimonite would then be decomposed as shown by equation *b*, and the series of reactions would proceed until all the antimony existed as antimonite, and all the sulphur as sulphide of a metal insoluble in cyanide. Only after all the antimonious sulphide in solution has been decomposed will the silver go into solution as cyanide. As a highly alkaline solution of antimonite has strongly reducing properties, it is evident it would not be a good solvent of metallic gold, and this emphasizes the difference between the treatment suitable for the extraction of gold and that for silver. Referring to the action of a strongly alkaline solution of cyanide on gold ore, it is well known that the solution of the gold from a sulphide ore is incomplete, owing to the formation of alkaline sulphide in the solution. It is also a fact, though not so generally known, that in the case of a thoroughly oxidized ore, quite free from sulphide, the extraction of the gold is greatly retarded by the use of a strongly alkaline solution of cyanide, such a solution taking three times as long to dissolve the gold as a neutral one or one slightly acid from the presence of HCy. The results given by Mr. Hobson of tests on gold-silver ores containing argentite, proustite, and pyrrargyrite can, I think, be accounted for from the reactions of compounds whose existence is well known, and without calling into being compounds such as mercurous sulphide and mercurous potassic cyanide, which are not found to exist under any other conditions.

Stronger proof than the 'negative probability' given by Mr. Hobson will be required before the existence of these compounds will be accepted. Little progress has been made in the development of the technical application of the chemistry of the cyanide process, compared to the mechanical improvement. Most cyanide chemists and managers have little leisure and few appliances for research work. Articles giving the results of original research work on the chemistry of cyanidation are rare, and one like that by Mr. Hobson should be greatly appreciated by the profession.

BERTRAM HUNT.

San Francisco, August 15.

CYANIDATION OF SILVER ORES

(September 26, 1908)

The Editor:

Sir—F. J. Hobson's account, in the *Mining and Scientific Press* of August 1 and 8, of the successful cyanide treatment of ores containing the sulphide and sulpho-salts of silver, is of great interest and value, both technically and historically; but his explanation of the reactions involved is decidedly open to question, and some of the equations put forward to support his views seem to be quite incompatible with established facts. An equation ought to express quantitatively a reaction going on between definite weights, or rather masses, of the original materials, yielding products of known composition, but in some cases at least Mr. Hobson has given us formulas representing substances whose non-existence has been

pretty conclusively proved, and has accepted feeble and indirect evidence as indicating their presence. I refer particularly to mercurous sulphide and to potassium mercurous cyanide (Hg_2S and KHgCy_2). The former of these has been shown to split up, if formed at all, into a mixture of metallic mercury and mercuric sulphide ($\text{Hg} + \text{HgS}$). While mercuric cyanide (HgCy_2) and potassium mercuric cyanide ($\text{K}_2\text{Hg}''\text{Cy}_4$) are well known and can be readily prepared and crystallized, the corresponding mercurous compounds have not been described, and find no place in chemical literature. A careful investigation which I made some years ago indicated, and the experiments described below, which have been made or repeated during the past few days, will, I think, prove that potassium mercurous cyanide cannot exist in solutions prepared under the conditions described by Mr. Hobson.

I believe that the beneficial effects which have been observed to follow the use of mercury salts in cyanide solutions can be sufficiently explained by the well known properties of potassium mercuric cyanide when used in conjunction with free alkaline cyanide as a solvent for the precious metals, coupled with its equally well known efficiency as a precipitant of soluble sulphides. For convenience of reference in discussing them, I have taken the liberty of numbering Mr. Hobson's equations (on pages 182 to 184 of the issue of August 8) consecutively from 1 to 19; other equations which I introduce are numbered beginning with 21. His equation, (2) $\text{Ag}_2\text{S} + 5\text{KCy} + \text{O} + \text{H}_2\text{O} = 2\text{KAgCy}_2 + \text{KCYS} + 2\text{KOH}$, expresses the fact that thiocyanate and potassium silver cyanide result from the action of potassium cyanide on silver sulphide in presence of air. This reaction appears to take place to some extent, but it is certain that another reaction also takes place, for even in the absence of oxygen silver sulphide is dissolved by cyanides, presumably thus:



This reaction is reversible. If we dissolve a fairly large amount of Ag_2S in a strong solution of KCy , and dilute it shortly afterward, more or less of the Ag_2S will be re-precipitated, proving that some of the sulphide radical remained in the solution. Or upon adding a little K_2S we will also get some silver thrown down as Ag_2S , which will re-dissolve upon adding more KCy , and so on. This fact was noted 50 years ago by Bechamp, and is recorded in Fresenius' 'Quantitative Analysis' under Silver. The reaction has been more recently studied by Berthelot, who found that in dilute (N/10) solutions nearly 100 molecules of KCy were required to balance one molecule of K_2S , in order to retain silver in solution, instead of four molecules, as equation No. 21 seems to indicate. To be exact, the equation given by Berthelot as representing the conditions of equilibrium is:

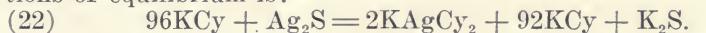

¹ The K_2S is probably hydrolized in water, forming $\text{KHS} + \text{KOH}$, but for the present purpose it is simpler to consider the K_2S as remaining in solution unchanged.

Now this proportion (96 mol. KCy to 1 mol. Ag₂S) means that 96 × 65 parts of KCy are required to dissolve and hold in solution 2 × 108 parts of silver in the form of sulphide, or 28.9 to 1, if none of the sulphide is oxidized. This value agrees remarkably closely with the ratio 30 to 1 which Mr. Hobson has found necessary in practical work with sands containing silver, presumably as sulphide, as he states that the chloride and bromide require much less.

If the solution containing KAgC₂ and K₂S with excess of KCy is exposed to the air for some time and then diluted, as a rule no silver sulphide is observed to form, but thiocyanate (KCyS) can be detected in the solution. No doubt this is owing to slow oxidation of the K₂S by oxygen, thus:

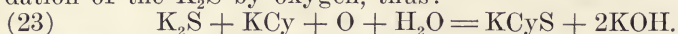

Equations 21 and 23 together are equivalent to equation 2 as given by Mr. Hobson, and quoted above, but it expresses the fact that the change goes on in two stages, and accounts for some of the soluble sulphides stated by him to invariably occur in the solution, as the latter step (oxidation of soluble sulphides) goes on rather slowly. I may add that large quantities of thiocyanate are found in the solutions obtained in the treatment of certain ores which carry only traces of silver but much sulphide of iron, and that other sulphur compounds, especially thiosulphates (such as CaS₂O₃) and sulphates, are also sometimes produced in working solutions, apparently by oxidation of soluble sulphides. In order to prevent the interference of the soluble sulphides with the solution of additional silver, or the re-precipitation of the silver already dissolved, they must be eliminated by oxidation or by precipitation with some suitable metallic compound.

As stated by Mr. Hobson (equation 3), the presence of zinc prevents any large accumulation of sulphide in solution; the reaction is, however, also reversible and incomplete, so that small amounts of sulphide cannot be removed in this way. Silver compounds are more effective, acting by virtue of the reversal of equation 21, which accounts for the re-precipitation of silver which is occasionally observed. It is obviously impossible to utilize them in practice. Lead compounds remove nearly all the sulphide, a soluble alkaline plumbite being usually first formed, in presence of an excess of alkali, which reacts with the sulphide:

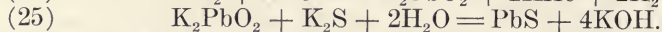
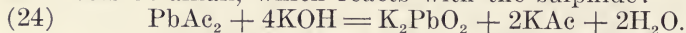

The most effective precipitants, however, of sulphides from cyanide solutions are soluble compounds of mercury, which form the double cyanide K₂HgC₂ and then react as follows:

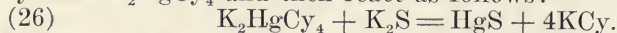

This reaction goes on to completeness, and there is no appreciable tendency for the precipitated HgS to re-dissolve. It only dissolves, if at all, in presence of oxygen or oxidizing agents, and without the re-formation of sulphide. In equations 7, 8, and 9 certain reactions have been ingeniously worked out to explain the solubility of stephanite and ruby silver ores. These are probably incorrect

in so far as they assume the existence of the mercurous salts above referred to, but the formation of soluble sulpharsenites of calcium and the like (or of potassium or sodium) probably goes on to some extent. These sulpho-salts, however, when brought in contact with double alkaline cyanides of silver or mercury, behave precisely like simple alkaline sulphides: for instance, $\text{Ca}_3(\text{AsS}_3)_2$ acts as if it were $3\text{CaS} + \text{As}_2\text{S}_3$ (or, in presence of sufficient CaO , as $6\text{CaS} + \text{As}_2\text{O}_3$), precipitating mercury as HgS and silver as Ag_2S , unless a sufficient excess of KCyanide is present, until all the S is finally removed.²

Mercuric cyanide is a salt which in solution fails to give many of the reactions usual with mercuric compounds. This peculiar behavior is explained by its being practically undissociated. It is, however, decomposed by soluble sulphides, and by certain metals, such as zinc or copper. It is well known that mercuric oxide, or mercuric chloride, in the presence of an alkali, when added in excess, will decompose more or less rapidly all other simple or double cyanides, all the cyanogen being finally converted into HgCy_2 ; this being the basis of various methods of estimating total cyanogen in solutions. I have found by repeated experiments that when mercuric chloride is added to a mixture of KCyanide and K_4FeCy_6 , in a solution of alkaline reaction, the ferrocyanide is unaffected until enough mercury has been introduced to convert all the cyanogen of the simple KCyanide into HgCy_2 . That is to say, 130 parts of KCyanide protect the ferrocyanide until 200 parts of mercuric mercury have been added, according to the equation:

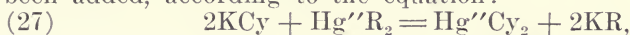

where R stands for an equivalent of chlorine, oxygen, nitric acid, or other radical in some mercuric salt. When a mercuric salt is added in excess of this amount the ferrocyanide is gradually decomposed with the formation of some ferricyanide (sometimes prussian blue), and with large excess it is finally and completely decomposed, all the cyanogen going to HgCy_2 .

When mercurous salts are mixed with an excess of solution of KCyanide the reaction taking place is, as admitted by Mr. Hobson in the case of the chloride, of this character:

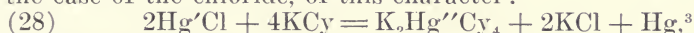

²Bertram Hunt has explained this more fully in your issue of August 29, which has reached me since the above was written. He does not, however, take into account the effect of mass-action, whereby a certain amount of silver is dissolved, even in the presence of sulphides in solution, provided that the cyanide is present in sufficient excess.

³Bertram Hunt (*Mining and Scientific Press*, August 29) points out that, with an excess of HgCl , all the cyanogen combines to form HgCy_2 . The second reaction he suggests is probably erroneous in showing no metallic mercury deposited, and requiring the presence of oxygen. The following:

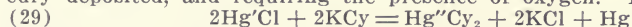

seems more probable, as metallic mercury is invariably reduced. Even crystallized $\text{K}_2\text{Hg}''\text{Cy}_4$ when dissolved and mixed with HgCl yields metallic mercury:



I have not had an opportunity to test the last two equations quantitatively, but they appear to agree with observed facts.

exactly half of the mercury being separated as metal. But he claims that, in the presence of a sufficiency of a ferrocyanide some other reaction takes place, with the formation of a double mercurous cyanide, hitherto unknown, no mercury separating, and states that some reducing agent such as the ferrocyanide is necessary to produce this effect. To test this assertion I took the following amounts of material, adding the powdered HgCl to the solutions of the other salts:

- (a) 0.192 gm. KC_y
0.25 gm. HgCl (containing 0.212 gm. Hg)
50 c.c. water.
- (b) 0.192 gm. KC_y
0.216 gm. K_4FeCy_6 crystals
0.25 gm. HgCl
50 c.c. water.
- (c) Same as (b).

In both (a) and (b) almost exactly half of the mercury was found in the solution, and half in the form of precipitated metal, as demanded by equation (28). After standing 15 minutes the ferrocyanide remaining in solution (c) was found by titration exactly the same as that originally taken, only a minute trace of ferricyanide being detected. Further, to test absolutely whether the mercury in the solutions containing ferrocyanides could be in the mercurous state, the following solutions were prepared:

(d) To 50 c.c. water 0.5 gm. HgCl was added and well stirred; 100 c.c. of 1% KC_y solution was then added.

(e) In 50 c.c. water 2 gm. K_4FeCy_6 crystals was dissolved; 0.5 gm. HgCl was added, and well stirred; 100 c.c. of 1% KC_y solution was added as before.

After stirring five minutes, approximately equal quantities of metallic mercury separated in each instance, and were filtered off after standing 15 minutes. Equal portions of the clear solutions were taken in two beakers, platinum electrodes were placed in each, connected in series, and both were electrolyzed. The amounts of mercury deposited on the two cathodes were exactly the same, proving that the mercury in each solution was in the same state of oxidation; whereas, if the first (d) contained mercuric, and the second (e) mercurous mercury, as Mr. Hobson contends, the mercury deposited in the latter case ought to have weighed double as much as in the former. These experiments, which can be easily verified in any laboratory, seem to effectually disprove any claim of the existence of a double mercurous cyanide in such solutions.

Of course, the use of double potassium mercuric cyanide as a solvent or accessory to the solution of gold has been known for many years, having been mentioned by Skey in a New Zealand publication about 1876, and by C. H. Aaron and others in the *Mining and Scientific Press* in 1891; it has also been the subject of patents by Hood and Keith in this and other countries. As pointed out by Skey, when dissolving metallic gold, the action of KC_y is accelerated at first by the addition of mercuric salts, but retarded later

owing to the protective effect of the film of mercury or amalgam produced.

The following is a summary of some results obtained in the investigation before referred to, and may be of interest in this connection. In these tests pure crystallized salts were taken, dissolved in distilled water, and tested with gold and silver foil, with the results stated.

Pure $\text{Hg}''\text{Cy}_2$ solution:

No appreciable effect on gold or silver.⁴

Basic Hg'' cyanide, HgO.HgCy_2 :

No appreciable effect.

Pure $\text{K}_2\text{Hg}''\text{Cy}_4$:

Very slight action on gold⁵ if dilute and cold; slight solution of gold if stronger; more rapid if heated. Mercury is precipitated as gold dissolves. With silver the action is similar but more rapid.

$\text{K}_2\text{Hg}''\text{Cy}_4$, with little KCy :

Action much more rapid, both on gold and silver, than with either salt separately. One atom of metallic mercury is precipitated for two atoms of metal dissolved, whether gold, silver, or copper.

$\text{K}_2\text{Hg}''\text{Cy}_4$, plus equal weight of KCy :

Action very rapid, but more gold and silver are dissolved in proportion to the mercury deposited than with less free KCy . Action becomes slower when a considerable coating of Hg has accumulated. Platinum is also attacked.

$\text{Hg}''\text{Cy}_2$ with either KOH , NaOH , NH_4OH , or Na_2CO_3 :

Gold and silver dissolved, with deposition of metallic mercury.

$\text{Hg}'\text{Cl}$ (mercurous chloride), plus K_4FeCy_6 , plus excess of KCy :

Solution (after filtering off the metallic mercury which separates) dissolves gold or silver with deposition of metallic mercury.

When either metallic gold or silver is dissolved by any of the above mercuriferous solutions, the effect is probably partly due to replacement of one atom of Hg in the K_2HgCy_4 by two atoms of Au or Ag, which is independent of the presence of oxygen, and partly (if air is accessible) to the action of the free KCy , which is accelerated at first by the influence of the mercury-gold couple thus formed. When Ag_2S is similarly dissolved, this is an exchange of one atom of Hg for two atoms of Ag, the HgS formed being insoluble, and therefore without influence in retarding the dissolving of further portions of silver. There is an obvious economy in mercury lost, when all possible extraction is effected, by the aid

⁴C. McPhail Smith finds that a small amount of silver is dissolved by HgCy_2 and displaces metallic Hg, when spongy silver is used in a hot solution.

⁵Generally, metal in a spongy condition, such as cornet gold or cement silver, or rolled strips previously deeply etched, was more rapidly attacked than smooth rolled gold or silver, even when the surface of the latter was most carefully cleaned.

of simple cyanide with air-oxidation, before resorting to the use of mercuric salts.

W. J. SHARWOOD.

Lead; South Dakota, September 3.

(December 12, 1908)

The Editor:

Sir—As a distant but appreciative spectator of the strenuous efforts now being made to develop the cyanide treatment of Mexican silver ores, I have read with much interest F. J. Hobson's article upon certain phases of the subject, in the *Mining and Scientific Press* of August 1 and 8, and look forward to further elucidation of the points raised. The statements that argentite is readily soluble in cyanide solution, while practically no extraction can be obtained from native silver, are of great interest and importance, in view of the author's long practical experience. It is not, however, clear how the interference with mill-solutions of ferrous iron, existing as ferrous sulphate in the ore, is removed by preliminary treatment with lime, as the ferrous hydrate formed consumes oxygen, or reacts with potassium cyanide to form double potassium ferrocyanide. Also it is difficult to see why the percentage of moisture in a slime-residue is affected by the cyanide content being 0.01% KCy, or any other percentage.

Mr. Hobson's equation to express the dissolving of argentite seems an incomplete expression of the truth, and would be clearer if expressed in two stages, thus:

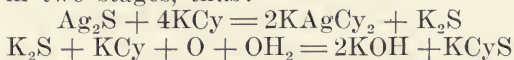

In the above form the origin of soluble silver sulphide existing in limited quantity at any one time in the solution is explained, apart from the formation of this substance by the action of an alkali hydrate on base-metal sulphides present. Further, the above two-stage reaction is not incompatible with the formation in solution of soluble sulphur compounds other than sulphides or thiocyanates, as already detailed in your columns of May 2, 1908 (p. 594). Mr. Hobson's suggested reaction for the removal of soluble sulphides by means of potassium-zinc cyanide forms the basis of A. F. Crosse's process for regenerating free potassium cyanide from the double zinc-potassium cyanide in working solutions by means of alkaline sulphides. (Proc. Chem. Met. & Min. Soc. of S. A., p. 272, March, 1903, Vol. III.) This reaction is incomplete in cold dilute solutions, and it appears probable that soluble sulphides are likewise removed by oxidation during aeration of the charge, while the occurrence of sulphur in the zinc-boxes may also be attributed to reduction of potassium thiocyanate by nascent hydrogen, resulting in the formation of zinc sulphide, thus:

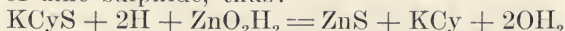

As Bertram Hunt has already dealt with the hypothetical existence of mercurous sulphide and cyanide, and the incompatibility

in solution of mercury compounds and soluble sulphides, I will confine myself to pointing out certain deductions from Mr. Hobson's experiments which do not appear to confirm the conclusions at which he has arrived. For this purpose I have tabulated the results of the parallel tests as follows, though some details of their execution are lacking, as well as any mention of the original and final assay-values of the material experimented upon:

Reagents.	Extraction, %.	
	Silver.	Gold.
(1) 0.5% K ₂ HgCy ₂ + 0.5% Ca(OH) ₂	30
(2) 0.5% K ₂ HgCy ₂ + 0.5% Ca(OH) ₂ + 0.2% K ₄ FeCy ₆	86	..
(3) 0.3% K ₂ HgCy ₂ + 0.2% K ₄ FeCy ₆ + 0.2% KCy + 0.5% Ca(OH) ₂ *	85	80
(4) 0.5% KCy	51	90
(5) 0.2% KCy	32	90
(6) K ₄ FeCy ₆ + Hg ₂ Cl ₂ or HgCl ₂
(7) 0.3% K ₂ HgCy ₂ + 0.2% K ₄ FeCy ₆ + 0.2% KCy	43	90

*The presence of lime in test (3) is inferred from the account of test (7).

The relatively different extractions of silver and gold, under the varying conditions shown above, confirm the statement that the same factors affect differently the extraction from the two metals (see *Mining and Scientific Press*, p. 295, August 29, 1908).

As regards the silver, the use of free cyanide, together with potassium mercurous cyanide and potassium ferrocyanide, in (7) affords an extraction of 43%, intermediate between the plain cyanide results of 51% in (4) and 32% in (5), but the addition of lime to the reagents employed in (7) brings up the extraction to 85% in (3), so that the common practice of using lime is justified, while the advantages of potassium mercurous cyanide and its protective ferrocyanide in themselves are by no means clear. As regards the gold, plain 0.2% KCy solution in (5) yields as high an extraction (90%) as does this same cyanide content, plus potassium mercurous cyanide and potassium ferrocyanide in (7), while all these reagents, together with lime, merely serve to reduce the efficiency to an extraction of 80% in (3), which might be a serious matter with silver-gold ores containing much of their value in the latter metal.

Mr. Hobson points out that aluminum interferences are neutralized by the addition of lime, presumably by precipitation of aluminic hydrate, but how this last insoluble precipitate passes out of the charge with the solution through the filter-cloth, and finally comes to rest in the zinc-boxes, is not clearly set forth. The rôle of reducer attributed to potassium ferrocyanide by Mr. Hobson seems hardly required in a solution which is assumed to be charged with soluble sulphides, and in any case the addition of a reducer seems undesirable when the dissolving of gold and silver is so greatly accelerated by the presence of available oxygen in any form.

In conclusion, Mr. Hobson inferentially supports by his equations the utility of oxygen as well as of lime in the dissolving of silver sulphide, but while mercury compounds in solution may assist by precipitating soluble sulphides, as when HgCl₂ was found to

raise the silver extraction from 30% to 92%, the author's ingenious theory, claiming still greater merit for the alleged potassium mercurous cyanide, would receive a more unqualified acceptance if supported by the publication of the results of a detailed examination of the properties of this substance, and its effect upon the cyanide treatment of silver ore.

W. A. CALDECOTT.

Johannesburg, Transvaal, October 24.

(April 17, 1909)

The Editor:

Sir—I have read with interest the articles on the cyanidation of silver which have appeared recently in the *Mining and Scientific Press*. It is apparent from these that the chemistry of the process still presents many unsolved problems. In connection with the Wall Research Fellowship at the Utah State School of Mines, I am conducting a series of experiments on silver ores and minerals. A few of the more important results are tabulated below.

TABLE I.

No.	Method of Treatment.	Ag Dis-solved, mg.	KCy Con-sumed, mg.	Ag Dis-solved, %.
1	0.5% KCy solution	14.02	...	7
2	0.5% KCy solution	14.42	...	7
3	Solution charged with O ₂	40.50	75	19
4	Added 383 mg. PbAc ₂ (lead acetate)	190.92	271	88
5	Added 450 mg. PbAc ₂	170.20	256	79
6	Added 1000 mg. PbAc ₂	130.30	282	60
7	Added 227 mg. PbO	214.20	318	99
8	Added 500 mg. PbO	211.10	318	97
9	227 mg. PbO + 200 mg. Sb ₂ S ₃	41.85	...	19
10	500 mg. CaO + 200 mg. Sb ₂ S ₃	4.06	...	2
11	475 mg. Hg ₂ Cl ₂	198.00	312	92
12	1800 mg. Hg ₂ Cl ₂	126.30	600	58
13	1800 mg. Hg ₂ Cl ₂ + 300 mg. K ₂ FeCy ₆ ..	113.90	622	53
14	150 mg. SbCl ₃	140.80	527	68
15	150 mg. SbCl ₃ + 200 mg. Sb ₂ S ₃	90.90	615	42
16	500 mg. NaCl	33.80	...	16
17	243 mg. PbAc ₂	185.20	293	85
18	227 mg. PbAc ₂ + 227 mg. PbO	185.80	300	86
19	No Oxygen present	11.10	...	5
20	" " + 383 mg. PbAc ₂	73.94	144	33
21	" " + 383 mg. PbAc ₂	74.40	165	34
22	" " + 383 mg. PbAc ₂ + 227 mg. PbAc ₂	100.70	...	49
23	" " + 227 mg. PbO	18.88	...	9
24	" " + 227 mg. PbO	17.20	...	8
25	" " + 227 mg. PbO + 227 mg. PbAc ₂	127.60	184	59

In working with ores from various mines it was found that the many unknown factors made generalizations dangerous. Even a chemical analysis leaves important facts unknown, such as the form in which the elements are combined. Therefore many of the experiments were conducted on artificial ores in which active agents have been introduced one at a time. Not only is it true that the

the introduction of lime decreases the solubility of both native silver and gold in a cyanide solution. Also it is well known that oxygen, or an oxidizing agent, is essential for solution in both cases. With some of the silver compounds on the other hand, the introduction of lime or of an alkali is an important aid to extraction, and in the case of AgCl oxygen plays no part in the reaction. Percolation; soaking, and air-agitation tests have all been tried, but for the purpose of securing comparative results the ordinary bottle test is most effective.

The experiments given below, except those from which the air was excluded, were made in 8-oz. salt-mouth bottles. Ten of these were clamped in a frame, and rotated by a small water-motor. The speed was so regulated that the contents of the bottle would fall from one end to the other during each half revolution. As the bottles were only partly filled, the agitation and aeration were probably both as favorable as will obtain in practice. Most of the tests were run over night and the temperature varied from 10 to 20° C. In Table I are given results obtained on silver sulphide precipitated from a silver nitrate solution; 250 mg. of Ag₂S, equivalent to 217.7 mg. of silver, was agitated 17 hr. with 150 c.c. of a 0.5% solution of KCy. The extractions are based on solution-assays.

Duplicate tests, three of which are included in the above list, show that the variations in speed of rotation and temperature did not seriously affect the results. The air-tight tests, 13-25, were made in 160 c.c. Erlenmeyer flasks. After adding the Ag₂S and other chemicals, with the exception of KCy, the flask was filled with distilled water and the contents boiled under reduced pressure for about 15 min.; 800 mg. of pure KCy was then dropped in, the flask tightly sealed, and quickly cooled to the temperature of the room.

The amount of lead and mercury available in the compounds added to tests 4, 7, 9, 11, 17, 20, 21, 23, and 24, is the computed weight necessary to combine with the sulphur resulting from the complete decomposition of the 250 mg. of silver sulphide. The reason for the method of treatment in each case, and the most probable explanation of the effect produced, would involve a discussion of ionic equilibrium and other fundamental laws of chemistry, obviously beyond the scope of the present article. But readers who have followed closely the previous discussions of the subject (*Mining and Scientific Press*, May 2, Aug. 1, 8, and 29, Sept. 26, and Dec. 12, '08) will, I think, readily understand the 'wherefore' in the above experiments. It is clear that oxygen plays an essential part in dissolving silver sulphide in cyanide solutions. It is more important when litharge is the precipitant of soluble sulphides, than when lead acetate is used. It is also interesting to note that in cases where there is no excessive consumption of cyanide, the ratio of the silver dissolved to the cyanide consumed closely approximates 216:325. This is the proportion demanded by the most generally accepted equations.

The largest number of my experiments are being carried out

on silver minerals of a high grade of purity. These were secured from the Foote Mineral Co. and from the Museum of the University of Utah. One example will serve to illustrate the method of preparing the so-called 'ore samples' from these silver minerals. 1.6 gm. of a crystallized specimen of pyrargyrite (Ag_3SbS_3) was crushed with a few grams of quartz sand in a porcelain mortar, to pass a 100-mesh screen. This was then mixed with 550 gm. of quartz sand which had been ground on a stone bucking-board to avoid the introduction of iron. After adding 1.6 gm. of lime the sample was thoroughly mixed and quartered. Duplicate assays on this prepared ore gave 47.70 oz. silver per ton. 50 gm. of ore was introduced along with 100 c.c. of solution in 8-oz. bottles and agitated as in the previous tests. Agitation by compressed air on larger samples gave similar results. Extractions are figured on solution-assays in all cases except where these are shown to be in error by similar tests and by tailing-assays. In cases of almost complete extraction better results can be obtained by assaying the tailing. Except where otherwise stated, lime is present to the extent of 6 lb. per ton of ore, and the samples were agitated 17 hr. in a 0.5% KCy solution.

The above experiments, along with others not tabulated, prove rather conclusively that the usefulness of lead salts is limited to those ores containing silver as argentite, or in which there is danger of the silver being re-precipitated as Ag_2S . In case the silver is present as proustite, pyrargyrite, or tetrahedrite, the addition of lead salts in the presence of lime would seem to retard rather than assist solution. This fact will probably help explain the poor effect of lead compounds applied to a certain Mexican ore, as instanced by Mr. Caldecott (M. & S. P., Aug. 29, '08). The chemical reactions involved are obscure. The addition of stibnite, in the presence of PbO , in (3) is fatal. Also tests 9, 10, and 16, Table I, show its evil results. In case of the difficultly soluble silver minerals, I have not experienced the beneficial results of adding Hg_2Cl_2 (see tests 5, 6, 10, 11, 16, and 20) found by Mr. Hobson (M. & S. P., Aug. 8, '08) to hold true for some Mexican silver ores. Possibly some essential factor is lacking in my tests.

The use of litharge seems preferable to lead acetate when dealing with soluble sulphides, for reasons mentioned by Mr. Eye. Also it may be added in excess without seriously affecting results. I should like to know if its limited use in practice is due to controlling patents. I have attempted little more than tabulation of a few experiments in the present article. I shall later present fuller data in graphic form.

THEO. P. HOLT.

Salt Lake City, February 26.

TREATMENT OF A CONCENTRATE-SLIME

By A. E. DRUCKER

(April 4, 1908)

A description of my vacuum-filter process as applied to heavy mineral or concentrate-slimes may prove interesting, as it is quite different from other methods of filtering. I doubt whether a vacuum-filter of the Moore or Butters type will successfully treat this particular concentrate-slimes, as it is not to be compared with an ordinary ore-slimes. A combination of decantation and vacuum-filtering is the quickest and best method for such a product.

Very little information is obtainable from cyanide books or mining journals in regard to the cyanide treatment of concentrate. In a great many places the ore is concentrated before cyaniding and the concentrate shipped to the nearest smelter for reduction, the owners being content with high smelter charges and a 90% extraction. Most concentrates offer very little trouble to cyanide treatment providing the following points are observed:

1. To be treated fresh and re-ground in a tube-mill with strong cyanide solution so that of all the product passing to an agitator at least 90% will pass a 200-mesh screen.

2. To be mechanically agitated and aerated for 15 to 20 hours within an agitator as described below.

3. The cyanide solution to test not less than 0.4% KCN when new and to test as high as 0.6% total cyanides after being in use for some time. For a short treatment of 24 hours do not attempt to cyanide with weak cyanide solutions testing only 0.15 to 0.2% and expect to get the best results. When treating a fresh clean pyrite 2 or 3 lb. lime per ton will generally be sufficient for all purposes.

4. Do not allow the strong cyanide solution to become so foul as to become inactive. This is one of the serious troubles in treating concentrate. A newly made solution free from reducing agents will give the best extraction and have the greatest dissolving power, but as it becomes older and takes up various foreign substances, which act as reducing agents, robbing the solution of its oxygen, the extraction gradually diminishes. The cheapest and most effective way of maintaining the extraction and of overcoming this reducing action is by a thorough aeration while agitating the pulp with cyanide solution. In treating concentrate it is not a bad plan to make up a new strong solution every six months.

5. To rid the concentrate-slimes of its gold-bearing solution the combined method of decantation and vacuum-filtering will be found to be the most efficient. A description is given below.

During the past two years I have had ample time to prove the success of this combined agitator and filter for treating a concentrate-slimes at the experimental plant of the Oriental Con. Mining Co. in Korea. Before giving a description of the filter it may be well to describe in detail my method of cyanide treatment.

The concentrate when taken from the Frue vanners is prac-

tically clean; the material is conveyed to the tube-mill mixed with a little lime, and fed to the automatic feeder with strong cyanide solution. Upon passing through the tube and being slimed in cyanide, the pulp flows to a spitzkasten, which yields two products—the underflow coarse and the overflow slime. The coarse is caught in settling-boxes and returned to the tube to be reground. Strong cyanide solution (used also in the tube) from the upper stock-vat is used for the upward sizing current in the spitzkasten. The clear overflow from the coarse settling-boxes passes to clarifying sand-filters and thence to zinc-precipitating boxes or directly to the strong sump. In order to maintain a constant pressure for the feed at the tube-mill and for sizing, a small centrifugal pump circulates the solution from the strong sump to the upper stock-vat, the overflow being conveyed back to the sump. The overflow slime from the spitzkasten (90% passes 200 mesh) flows direct to the agitator, in which a muller with plow-shoes is revolving at 15 rev. per min. The muller is lowered so that the points of the shoes are within $\frac{1}{8}$ inch from the filter. Every charge receives from 18 to 20 hr. agitation and aeration. When aerating, air is forced beneath the filter and bubbles up throughout the charge. Everything seems to be actually boiling. Aeration and agitation are perfect at every point of the vat. After this operation is finished the agitation is stopped, the air turned off, the muller raised above the settled pulp, and all allowed to settle for 30 minutes. With the aid of a little milk-of-lime, scattered over the surface of the solution, settling will take place within 15 or 20 minutes. Next comes the decanting of the strong cyanide-gold solution, which can be done to within 30% moisture remaining with the settled pulp. It is not necessary to wait until the solution becomes perfectly clear before decanting, since it is run into sand-clarifying vats and from there flows as clear as a crystal to the zinc-boxes. These clarifying-vats also serve as gold-solution storage-vats, so that the flow to the zinc-boxes can be regulated. Within each of these vats is a burlap filter four inches from the bottom and on top of each is one foot of clean coarse quartz sand. If the solution to be decanted is slightly cloudy all the slime therein will form a thin layer on top of the sand and is removed with a scoop every 3 or 4 days. The slime does not seem to penetrate the sand readily.

The pulp remaining within the agitator contains 30% moisture in rich gold solution and is next vacuum-filtered down to within 18% moisture. The agitator is set in motion and the muller gradually lowered through the pulp until the plows just begin to touch the filter. The shoes revolving next to the filter prevent any slime-cake from forming, and when the suction is started beneath the filter, the gold-bearing solution is gradually sucked through into the compartment below. Before starting the vacuum the slime is quite thin when containing 30% moisture and agitates readily, there being no trouble in lowering the muller when plow-shaped shoes are attached. I have never found any other form of shoe that will successfully work down on this heavy thick concentrate-slime, espe-

cially the last layer of slightly coarser material next to the filter which packs like cement. With a good strong suction beneath the filter the total time required to decant a solution and vacuum-filter the remaining slime down to 18% moisture is about three hours. The slime containing 18% moisture is very thick and sluggish toward the last, but it is possible to filter to 16 per cent.

After the removal of the strong solution (0.5%) there follows

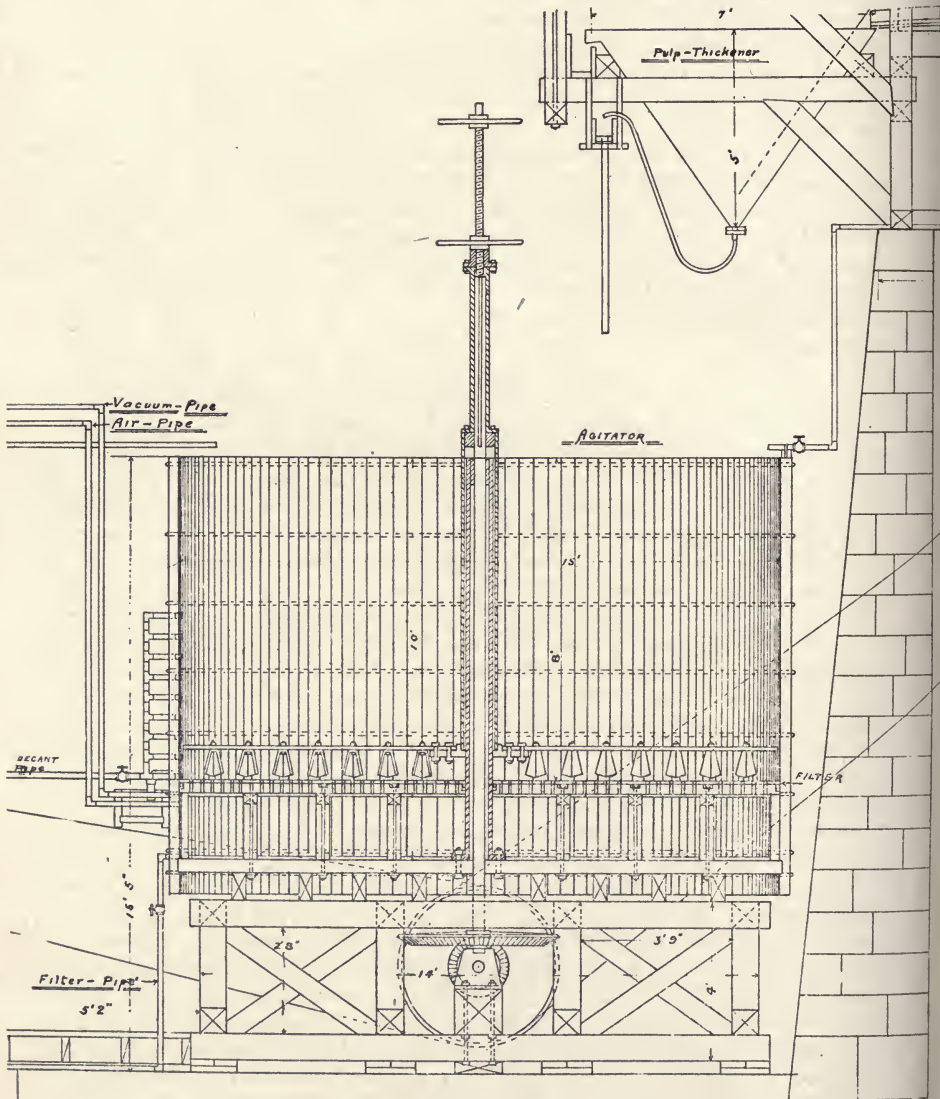

Fig. 36. COMBINED AGITATOR AND VACUUM-FILTER

a 0.25% cyanide wash, assaying two to three cents per ton, which is thoroughly agitated for a few minutes, settled, decanted, and vacuum-filtered. Lastly, a weak 0.1% wash, assaying a trace in gold, is applied in the same way, and upon the completion of this operation the extraction of the gold-bearing solution is practically complete. The charge is now ready to be run to waste. A little water is added, the discharge-hole opened, and the revolving of the muller will empty the agitator. A final water-wash is not necessary and consequently there are no waste solutions of any value. Both washes have their separate storage and clarifying-vats; they are run through their respective precipitation-boxes to corresponding sumps.

All details of construction of this filter will be found in the drawing. The muller has four arms at right angles to one another and to them are attached 26 cast-iron plow-shoes equally spaced. The shoes on opposite arms are arranged to work in between. The burlap filter is well braced 24 in. from the bottom and can neither bulge one way nor the other under pressure or vacuum. As a protection to the burlap one-inch boards bored with inch holes are placed on top and well spiked. The filter-cloth is between and the holes above should coincide with those below, as is shown in the drawing. The capacity of this 15-ft. agitator is 20 tons of clean pyrite-slime and it requires 5 hp. to run. The heavy pulp when once in motion at 15 rev. per min. takes very little power. The muller can be easily raised or lowered 2½ ft. During the past year I have obtained an actual extraction in bullion of 92% on a gold-bearing arseno-pyrite by the above method. This is a concentrate that gives a poor extraction (50 to 60%) by the ordinary 16-day percolation method.

An agitator of this type is particularly adapted to the treatment of a heavy sulphide slime. There is always a small amount of coarse concentrate that is bound to escape into an agitator from a spitzkasten, even though 90% of the total charge will pass a 200-mesh screen. That part remaining on a 200-mesh, and even the coarser portion passing a 200-mesh screen, will give serious trouble to any other form of agitator, on account of being unable to work down on a cemented concentrate. There is only one form of shoe that will do it and that is the pointed plow. The charge can be settled for days and even then the muller will work itself downward through the last layer of cemented concentrate. That portion which settles compactly is nevertheless very fine and will practically all pass a 150-mesh screen.

With this arrangement a separate vacuum-filter plant is not needed. All the different operations of collecting, agitating, aerating, decanting, and vacuum-filtering are performed in the one vat, and therefore the method requires a plant of the smallest size.

CONTINUOUS SLIME FILTER

By ROBERT SCHORR

(August 8, 1908)

Your journal has given the subject of filter-pressing slime more thorough and strictly professional attention than any other publication. It is obvious that most of the space has been devoted to discussion, and to illustrations of those vacuum and pressure-filters which have proved successful in actual practice. Among the several untried designs which have found due consideration, is also Bertram Hunt's continuous slime-filtering machine. The stationary type of this appliance has been clearly outlined in Lochiel M. King's able article, 'Cyanidation in Nevada,' of January 25, 1908. This machine is of special interest, as it is apparently the only slime-filter which employs sand as a filtering-medium. For that reason expressions of opinion and data would be greatly appreciated from Mr. Hunt and from all those who have made tests with sand as a filter-bed for slime, and for mixed slime and sand. I do not venture an opinion myself, as I have had no experience in the operation of slime-filters. They have, however, interested me greatly, and about 18 months ago I designed a continuously-acting filter-wheel, patents for which were granted recently.

The main object of this design was to create a filtering and washing apparatus which would be entirely automatic in its operation. Slime transfers are entirely eliminated, and consequently the time of treatment is reduced materially. In looking over the accompanying drawings it will be realized that a large filter-area can be accommodated upon a limited floor-space. No storage-vats, and but little attention and power, are required. Two cast-iron pump-chambers (1) anchored to the sides of a wooden box (2) are the supports and trunions on which the filter-wheel revolves. The wheel itself consists of three circular discs (3), thoroughly tied together by steel rods (4). These discs have grooves formed by cleats (5) for the support of filter frames (6) in a position tangential to a circle of a diameter smaller than the wheels. The filter frame can be made either of standard pipe, of cast-iron or wood with filter-cloth, preferably canvas, sewed around the same. The space between the two sheets can be filled in with matting or other porous material. Both sides of each filter leaf form effective filtering surfaces. Each frame is connected by means of pipes (7) to an iron ring (8) revolving with the wheel upon the pump chamber. Local openings in these bring the filter-frames, in the course of one revolution, into communication with the various pumps or other devices for the production of a vacuum for the purpose of withdrawing solution and wash-water, and for forcing off the filtered cakes of tailing by means of water or compressed air.

Corresponding with these three functions, namely, with the formation of cakes by sucking off solution, with the washing of the cakes and withdrawal of the wash-water, and with the discharging of the washed cakes by forcing them off, there are

three subdivisions of each pump-chamber. These three spaces, 9, 10, and 11, are connected individually to the necessary apparatus. The tailing falls into a launder (12), and is carried away either mechanically or with water. Various means may be used to revolve the filter-wheel. That shown in the transverse section is probably the most simple, consisting of an ordinary adjustable ratchet (13) operated from an eccentric (14).

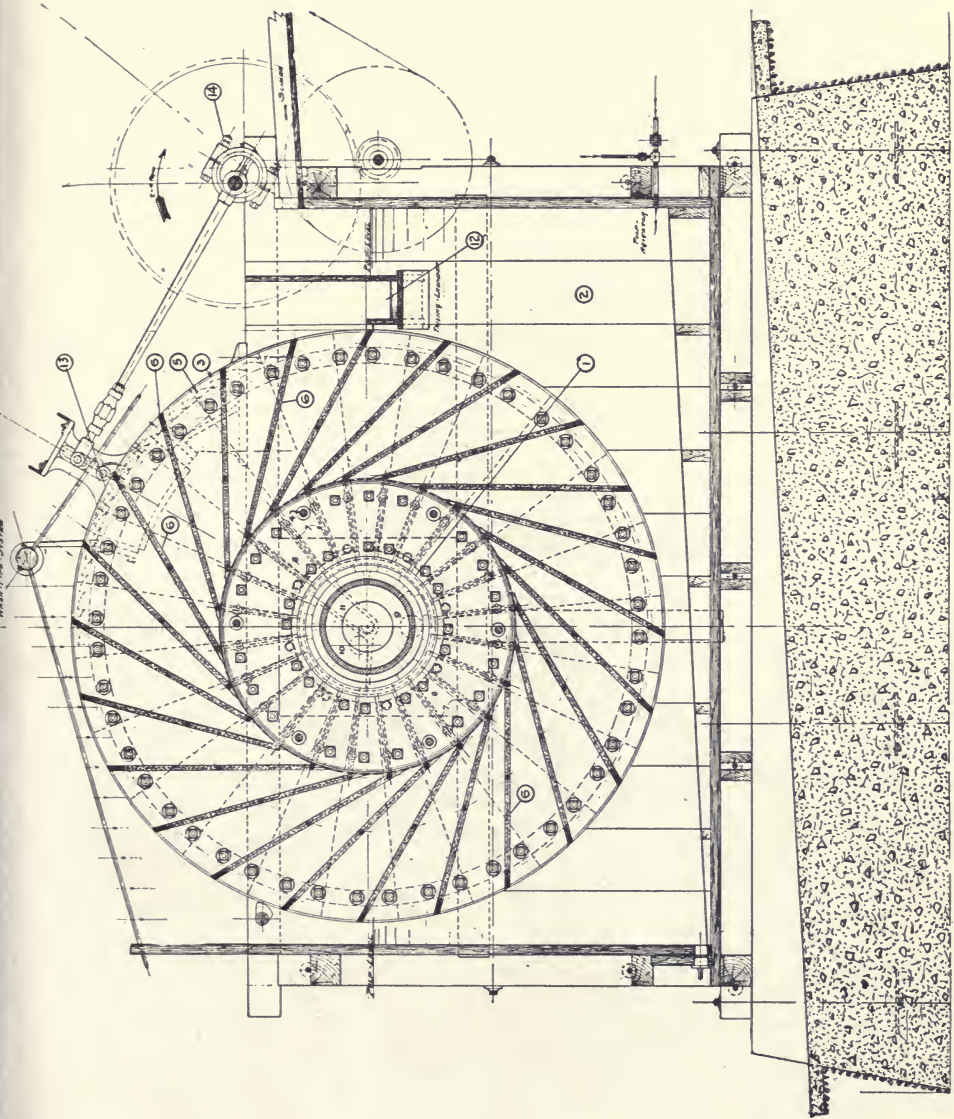

Fig. 37. SCHORR'S CONTINUOUS SLIME-FILTER. TRANSVERSE SECTION

The gearing and pulley indicated are necessary in view of the slow speed required.

In operation the slime enters the box below the driving-shaft and the level is kept as high as the tailing launder. During the slow travel of the filter-leaves through the pulp the cakes are formed, all solid matter being drawn by the vacuum to the filter cloth. By changing the speed of the wheel the thickness of the cakes can be regulated. During this period each filter is in connection with chamber 9, and the strong solution is obtained separately. The

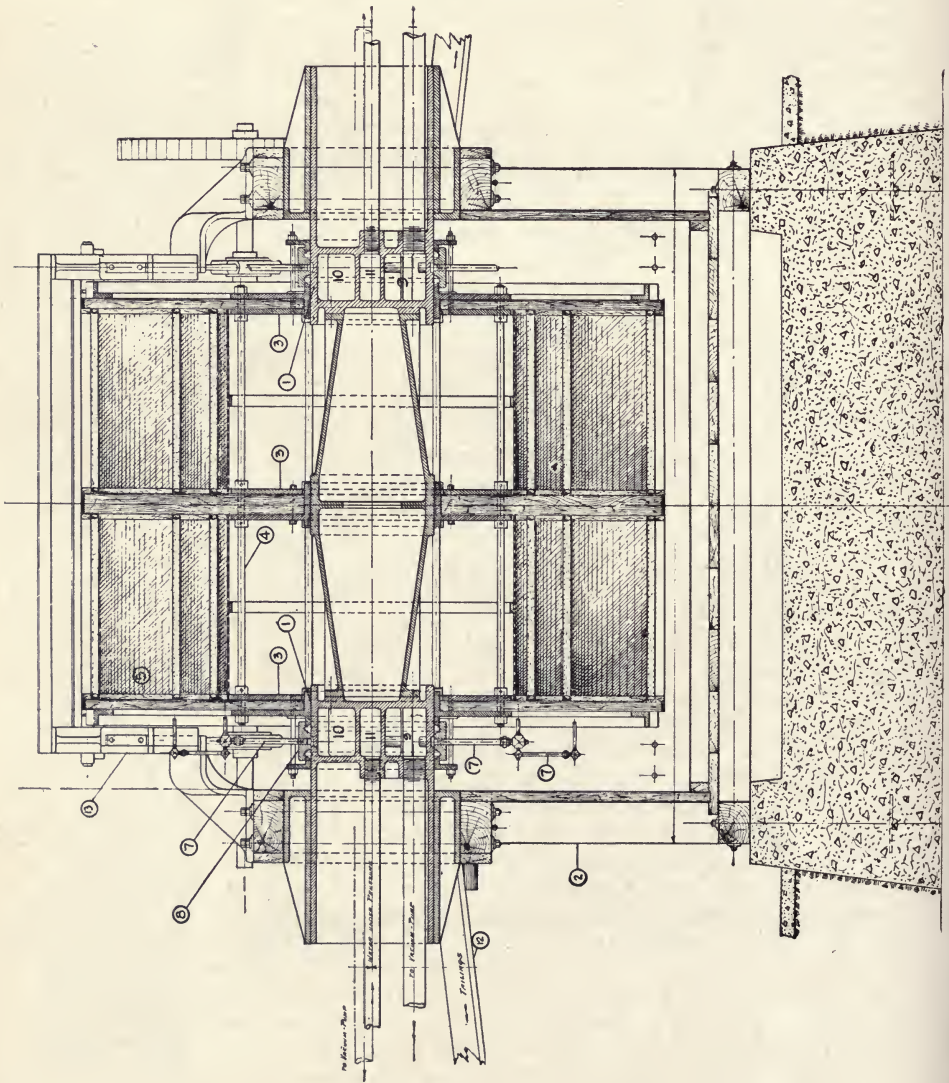

Fig. 38. SCHORR'S CONTINUOUS SLIME-FILTER. LONGITUDINAL SECTION

filter planes emerging from the box are subjected to a long water-wash, and the liquor is drawn off through chamber 10 by another pump. From the point where the filter-planes begin to slant toward the tailing-launders they communicate with the central space (11) of the chamber, which is connected to water under pressure or to a compressed-air main. In this manner the cakes are forced off into the tailing-launders for further disposition. Ample time is given for discharging, after which the operation is repeated.

The arrangement, as outlined, may be modified in different ways to suit the material under treatment. The filter-wheel can be housed in a steel shell, with an opening at the highest point for feeding the pulp to the machine. After applying a vacuum or pressure for some time, a door, placed at the lowest point of the steel housing, is opened to discharge the filtered material. Another variation of the design is effected by introducing the material to be filtered through the central shaft of the wheel.

CONTINUOUS SLIME-FILTER

(October 17, 1908)

The Editor:

Sir—Referring to Mr. Schorr's article in your issue of August 8, I note that he mentions Bertram Hunt's sand-filter, and suggests that it might be well for Mr. Hunt, or others, possessing data on the subject, to tell what they know about the method.

As filtering plays an important part in the economic reduction of ores by cyanidation, and as Mr. Hunt has adopted this principle of filtering in his continuous slime-filter, a few remarks based upon an observation and experience extending over nearly five years with this type of filter may prove of interest. In 1897 there were installed, under Mr. Hunt's direction, three of these filter-bottoms at the Black Oak mine, Tuolumne county, California, while working the tailing from the mill by cyanide process. One filter was used in an 18-ft. vat, and the other two in two 8-ft. vats. The filter in the 18-ft. vat was used for three seasons. During that time the filter was taken out twice for the purpose of cleaning. It is obvious that this type of filter cannot be used in cases where the vats are cleaned by sluicing instead of by shoveling. For this reason it was necessary to use a single thickness of burlap to protect the filter-bottom. On all the rest of the vats, using the ordinary filter-bottom, two thicknesses of canvas or burlap were used, and the false-bottoms were removed once a month to clean out the sand which had accumulated beneath them. Of the material handled at the plant, 90% would pass a 100-mesh screen, 70% would pass 150-mesh, and about 4% would pass 200-mesh. This class of material at best leaches rather slowly, but a comparison of the two types of filters showed that the sand-filter gave a clearer solution, and leached more freely than the canvas or burlap-covered bottoms.

These two vats were used chiefly for experimental or testing work, generally for leaching purposes, but also for clarifying the

solutions from the vacuum-pan. All kinds of materials were leached in these two bottoms—slime, sand, and concentrate. For the last two years I used these filters exclusively for filtering solutions prior to passing to zinc-boxes. They were practically in daily use for one purpose or another for nearly five years. I examined them on several occasions and found that the material which had been worked on these filter-bottoms had not found its way to any extent down the V-spaces through the 10-mesh (coarse sand) filling, showing clearly that, where capable of application, the sand-filter out-classes in general efficiency, cheapness of construction and maintenance, any other style of filter-bottom, whether used for the leaching or merely as a clarifying medium. The method followed in the construction of these filter-bottoms at the Black Oak mine was as follows: upon the floor of the vat were first laid pieces of 2 by 2-in. scantling, planed, about 12 in. apart, and parallel to one another. These were notched at intervals on the under side to allow free circulation of the solution. Resting on these scantlings, triangular pieces (made by cutting 2 by 3-in. scantling diagonally) were placed. The edges of the bases were placed about $\frac{1}{2}$ in. apart, the ends conforming to the circumference of the vat. In the V-shaped spaces was first laid sharp quartz passing a $\frac{3}{4}$ -in. screen. Enough of this material was used to act as a retaining floor for the next layer of material, which was $\frac{1}{4}$ in. clean quartz. This was used to fill the V-spaces to about an inch from the top. Sufficient coarse sand (10 mesh) was then put in to level off. It would be natural to suppose that the sand and slime would eventually work down to the apex of the V-spaces, but it does not seem to do so to any appreciable extent. As soon as the filter has bedded itself, there will be no trouble with muddy solution. I have frequently used this type of filter in laboratory work, where I have found it equally efficient.

E. N. WALKER.

San Francisco, August 20.

MILING PRACTICE IN NEVADA GOLDFIELD REDUCTION WORKS

By E. S. LEAVER

(August 22, 1908)

The mill of the Nevada Goldfield Reduction Works at Goldfield is a custom plant, all ore being received through the sampling works. As the ores are sampled and purchased in small lots, this allows mill-results to be followed closely, and as the ores come from various mines and leases, including surface-dumps and deep workings, the results and treatment vary considerably. The surface, or oxidized ores, readily give high extraction by simple treatment. The sulphide ores require close attention, and in depth are becoming even more complex. The deeper ores, now being marketed, require close concentration, almost absolute sliming, and not less than 10 days'

cyanide contact. The treatment consists in crushing wet by stamps, amalgamating on plates, concentrating on Wilfley tables, fine-crushing of the sand in a tube-mill, re-amalgamation on plates, re-concentration on vanners, and cyaniding of the sand and slime.

The ore is crushed in weak cyanide solution (0.1%), and while this has been the practice for over a year, no particular effects are noted on the plates. The entire recovery has been better than formerly when crushing with water. The plates require more attention, but all pitting is avoided and the amalgamation has been good. By crushing in cyanide, treatment is favored, in that the

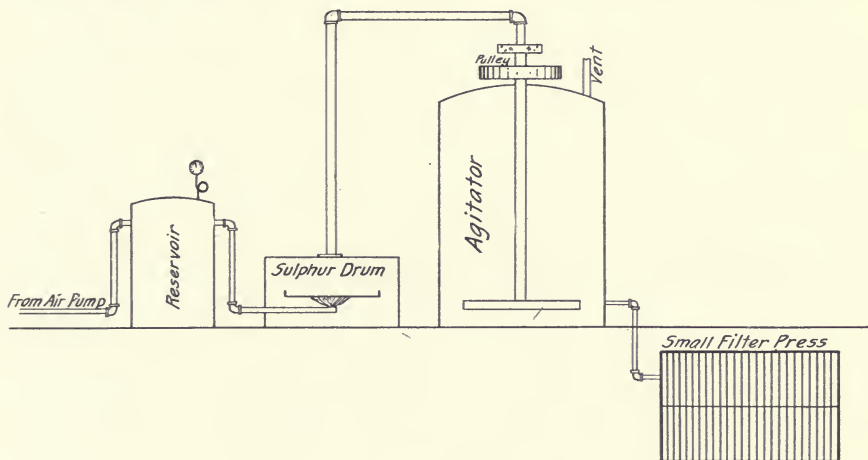

Fig. 39

ore is at once in contact with the solvent, and there is elimination of the loss of time in settling, decanting, etc. Also this practice avoids the loss in weak solution necessary in cyanide-plants where the ore is crushed in water or taken into the cyanide plant with water. In addition to the usual losses in waste-solution, the cost of water is an important item at Goldfield. Having only limited fall from the Wilfley tables to the tube-mill, advantage is taken of Wilfley tables as sizing machines, making three products, sand, slime, and concentrate. Only the sand is taken to the tube-mills, the aim being to grind it as fine as possible, and to favor passing as much of the finest sand as commercial treatment allows with the slime proper. As the ore in various mines differs, the percentage of slime and sand will vary, but approximately 20% of the original weight is treated as sand. This sand will pass the 100 mesh, and requires 10 to 20 days' double treatment by percolation, that is, the sand is collected and treated in an upper row of vats, discharged, and re-treated in a lower row of vats. Good success has attended the use of a substitute for tube-mill pebbles. The Danish pebbles were originally imported at a cost of about \$60 per ton. A number of samples picked from medium low-grade ores were experimented

with. The result was the finding of a close-grained compact ore which is an excellent substitute for the imported pebbles. Several tons of lumps can be selected from the ore in a short time. These lumps, varying in size, are fed into the mill, and in a short time it requires close inspection to detect them from the genuine imported pebbles. Results from these pebbles show a saving of \$100 per mill per week.

The crushing or circulating solutions, after passing the concentrators, including the sand-collection vats, flow to large slime-collection vats, and the clear solution is taken off by rim-launders and decanters. This circulating solution then passes through its special zinc precipitation boxes, and is returned to the battery-tanks to be again used under the stamps. When the slime at the collecting vats is at a proper specific gravity it is pumped to the treatment vat, where the strength of the solution is brought up if necessary. There it is agitated and aerated by circulation through centrifugal pumps, until the gold is in solution. This requires from 4 to 10 days. The slime is then separated from the gold-bearing solution by leaf-filters.

After a commercial failure with a well-known leaf-filter a number of experiments were made in the mill which led to the designing of a leaf which has given excellent results. The ordinary form or size of leaf was continued, but a filler was adopted that leaves no chance for clogging. This has been in constant use at these works for about one year, and has given perfect satisfaction. The canvas for the filter is sewed around the bottom and sides, making a bag about 5 ft. deep and 10 ft. long; the sewed edges are turned inside the bag; then, excepting about a three-inch strip along the sides and bottom, which is left for the pipe-frame work and suction, the entire filter is divided by stitching vertically in lines two inches apart, making pockets open at the top and bottom. Into these pockets are pushed grooved slats made of common lath. The grooves are about $\frac{1}{16}$ in. deep and about $\frac{1}{4}$ in. wide. Two grooves run lengthwise on each face, and each groove is placed so as to alternate with the groove on the opposite side, so as not to weaken the slats. Various experiments were made to determine the proper size of slat, number of grooves, etc., and the above was finally adopted.

Zinc fibre is used as a precipitant. The resultant product is roughly cleaned up, thrown into a small agitating-vat, and cut down by sulphurous acid. Sulphurous acid is a solvent for lime, zinc, and copper, making it preferable to sulphuric acid. The sulphur is shipped in, and is burned, the gas passing directly into the agitating-vat containing the zinky product and water in circulation. After the impurities are in solution, the fine gold and silver residues are drawn into a small filter-press, dried, and melted into bullion, which is sold to the United States mint.

MILLING PLANT OF THE MONTANA TONOPAH MINING COMPANY

By G. H. ROTHERHAM

(September 5, 1908)

The reduction of silver ores by wet milling and cyaniding, which has been studied to good purpose in Mexico, has had a comparatively limited field in this country. Doubtless the best practice is to be found at Tonopah, Nevada, where three well equipped mills are now successfully treating silver ores. The latest of these, the Montana Tonopah Mining Co.'s plant, designed and erected under the supervision of the consulting metallurgist of the company, F. L. Bosqui, and equipped by the Allis-Chalmers Co., possesses certain unique features which may be considered innovations in the metallurgy of silver. The ore is a gold and silver-bearing sulphide. The chief gangue-mineral is quartz, the vein-matter being a quartz replacement of the andesite. In the milling-ore the proportion of gold to silver by weight is 1 to 100. Some of the gold is undoubtedly free, the remainder being associated with the silver in the sulphide. The prevailing silver minerals are stephanite and polybasite; while beautiful specimens of ruby silver have been taken from the richer portions of the mine. Lead, copper, and zinc also occur in small quantity.

The ore, as it comes from the mine, is delivered to a 200-ton steel bin, which stands directly in front of the head-frame and adjoins the primary crushing plant. From this bin the ore is fed through a counterbalanced gate to a No. 5 K Gates gyratory breaker, which reduces it to 2-in. size. Thence it passes to a No. 5 B Gates bucket-elevator that discharges into an iron-frame revolving screen with one-inch perforations. The oversize from this screen is re-crushed in two No. 3 D Gates breakers to 1-in. size, this product then joining the undersize from the screen and passing to a 14-in. belt-conveyor, which conveys the ore to the mill-bins. This belt is 190 ft. long, and operates at an angle of 12°. It discharges onto a horizontal belt extending the length of the bins, the latter being provided with a tripper for distributing the ore. The crushing plant has a capacity of 25 tons per hour, and is operated only during one 8-hr. shift. From the bins the ore is delivered by eight suspended Challenge feeders to a battery of 40 stamps. The stamps weigh 1050 lb. and fall 100 times per minute through a 7-in. drop. The battery is the three-post, back-knee type, with wooden mortar-blocks, composed of 2-in. planks solidly spiked together and set on rubble concrete. The mortar is the Allis-Chalmers 'Homestake' narrow pattern, with extra heavy base. The battery is arranged in eight separate units, operating independently. The main counter-shaft rests low on the battery-sills, admitting of the prompt shut-down of any unit without hanging up the stamps individually. The shoes are of chrome-steel. The dies are made at a local foundry, and consist of 35% car-wheel scrap, 1/2% powdered manganese, and the remainder of chrome scrap. These dies give good satis-

faction, whereas the chrome-steel dies were found to 'cup' badly.

The ore is crushed in cyanide solution through 20-mesh woven-wire screen, with the diameter of wire 0.016 in., and an aperture of 0.0173 in. The strength of the circulating mill solution is 0.13% cyanide of sodium. The average size of the crushed battery pulp is shown by the following screen analysis:

	Per cent.
Remaining on 30-mesh	2.53
Passing 30-mesh, on 60-mesh	25.5
Passing 60-mesh, on 80-mesh	4.8
Passing 80-mesh, on 100-mesh	6.1
Passing 100-mesh, on 200-mesh	16.0
Passing 200-mesh	45.07

From the battery the ore goes to eight 24-in. cone-classifiers, with 50° sides. The spigot-discharge feeds eight Wilfley concentrators, the slime and fine sand-overflow joining the main pulp-stream after concentration. The whole mill-stream is then elevated to two Dorr classifiers for de-watering and further classification, preparatory to tube-milling. The Dorr machines are doing satisfactory work, but, as manufactured, were too lightly constructed, and had to be extensively reinforced. The best consistence of pulp for tube-mill purposes was found to be about 45% moisture. The excellent work done by these classifiers in separating a sandy product is shown in the following sizing tests:

PULP DISCHARGE FROM DORR CLASSIFIERS TO TUBE-MILLS.

	Per cent.
Remaining on 30-mesh	6.2
Passing 30-mesh, on 60-mesh	42.6
Passing 60-mesh, on 100-mesh	21.2
Passing 100-mesh, on 200-mesh	16.2
Passing 200-mesh	11.6
Loss	2.2

It is worthy of note that 70% of the pulp entering the mills is coarser than 100-mesh, and that the slime has been almost completely separated.

SLIME OVERFLOW FROM DORR CLASSIFIERS.

	Per cent.
Remaining on 100-mesh	2.5
Passing 100-mesh, on 200-mesh	15.5
Passing 200-mesh	82.0

The two tube-mills in use are the Allis-Chalmers, spur-gear driven, trunnion type, 5 by 22 ft., lined with 4-in. silex blocks. They make 27 r.p.m. The initial starting-load for one mill requires 60 hp., while both mills in simultaneous operation take 85. Each mill is now re-grinding 52 tons per 24 hr. This is the safe limit for this ore, considering the fineness of pulp desired for the best economical work in the cyanide plant. The size of pulp issuing from the tube-mills is as follows:

	Per cent.
Remaining on 60-mesh	1.0
Passing 60-mesh, on 80-mesh	1.5
Passing 80-mesh, on 100-mesh	4.0
Passing 100-mesh, on 200-mesh	27.5
Passing 200-mesh	66.0

The pulp from the tube-mills, after proper dilution, is reclassified in two 48-in. cones with 50° sides. The underflow from these is returned to the mills; the overflow joins the stream from the lower ends of the Dorr classifiers, and passes to three 8 by 54-in. Frenier sand-pumps, which elevate it to two thickening-cones, preparatory to secondary concentration on Frue vanners. This pulp, representing the final re-ground product, shows the following distribution of sizes:

	Per cent.
Remaining on 100-mesh	2.8
Passing 100-mesh, on 120-mesh	7.6
Passing 120-mesh, on 150-mesh	8.6
Passing 150-mesh, on 200-mesh	8.9
Passing 200-mesh	72.1

The Frue vanners, though not ideal slime-concentrating machines, do good work on this fine product. The concentrate from the Wilfleys and vanners is removed by traveling buckets to a drying-house adjoining the mill, where it is sacked for shipment to the smelter. From the lower concentrating floor the whole re-ground mill-pulp goes to the cyanide plant for treatment by agitation. All cyanide tanks are made of redwood, excepting the Hendryx agitators. These are constructed of Oregon fir, which, in my opinion, is inferior to redwood for cyaniding purposes. The mill-pulp, containing six parts of cyanide solution to one of ore, is fed alternately to the centre of three settling-tanks 30 ft. diam. by 10 ft. deep at the centre, with a false-bottom sloping 12°. These tanks are provided with leveling rim, overflow launders, and decanting apparatus. By means of a series of decantations, the pulp is reduced to the proper consistence for agitation. Every twelve hours 75 tons of pulp, the contents of one settler, are transferred by a 6-in. Morris centrifugal pump to two of the agitators. There are six Hendryx agitators in use, 17 ft. diam. It requires 6 hp. to agitate a charge of 35 tons of ore (dry weight). The pulp in the agitator has a specific gravity of 1.28 to 1.32. A 0.2% solution of NaCy is used, and 0.3 lb. lead acetate per ton of ore. The agitation is continued for thirty-two hours. The pulp is then drawn through the same pump as mentioned above, and raised to a pulp-storage tank, 30 ft. diam. by 17 ft. deep, provided with stirring-arms making 8 r.p.m. From this tank the pulp is drawn as required into the Butters filter-boxes.

The Butters plant consists of two redwood boxes, of four compartments each. Each box contains 72 filter-leaves. Pulp and solutions are handled by an 8-in. Morris centrifugal pump, and a 12 by 10-in. Gould duplex vacuum-pump. The solution from the Butters filter is re-filtered in a 30-in. frame filter-press, whence it flows to the precipitation tanks. There are three of these, 14 by 14 ft. The zinc-dust is added as an 'emulsion' from a small feed-cone, and passes directly into the suction of the pump, which raises the solution to the Merrill precipitation-presses set up in a separate building, 100 ft. above the precipitation-tanks, and immediately above two 28 by 8-ft. solution-storage tanks. These two presses

have triangular-shaped plates, 48 in. on edge. There are thirty plates in each press, with frames spaced 2 in. apart. The solutions are raised by a 5 by 6-in. Aldrich triplex pump. From the presses the barren solution runs to the storage tanks, where it passes into the general mill-circulation. The present method is to draw from the circulating mill-supply of solution the quantity required for agitation purposes. This amount is brought to the required strength in the agitators, and, after precipitation, it passes again into the mill-circulation; so that there is really but one solution used throughout. The value of the mill-solution is kept low by precipitating about 150 tons of it daily. That portion of the mill-solution which is not used for extracting purposes overflows the rim of the settling-tanks almost clear, but is further clarified by flowing through a three-compartment, pointed, clarifying-box, each compartment being 10 ft. square at the top. Thence it flows to the mill-sump and is raised by means of an 8 by 12-in. Gould triplex pump to a 70,000-gal. concrete reservoir on the hillside above the stamps.

Zinc-dust precipitation, as used by C. W. Merrill at the Home-stake plant, South Dakota, and elsewhere, has been satisfactory in the practice at Tonopah from the first. It has the advantage of compactness, low cost for labor, and security from theft. The helper who tends the solution and water pumps gives a portion of his time only to the simple manipulation of the process. In estimating the cost of precipitation, I have not included the cost of raising the solution to the presses, inasmuch as this would have to be raised in any event for purposes of circulation; and the additional work on the pump imposed by the presses themselves may be disregarded, as the pressure at the presses never exceeds 8 lb. per square inch, and reaches this point only just before the clean-up, when the frames are loaded.

The precipitate is sacked and shipped by express to the smelter. It was found, by careful calculation, that the high cost of fuel, fluxes, and labor would not justify refining this product on the ground, although an average sample of 114 lb. refined experimentally without acid treatment yielded 966.9 oz. (Troy) bullion, of a total fineness of 946.59. The following figures refer to a period of eight months, from October 1, 1907, to June 1, 1908, during which interval 34,766 tons of ore was treated, and 95,657 tons of solution precipitated.

Zinc-dust—33,903 lb., at 8.2c. per lb.....	\$2,780.00
Filter cloth—1368 yd. twill, at 34.25c. per yd.....	413.82
Labor—one-third time of one man, at \$4 per 8-hr. shift	960.00
Total	<u>\$4,153.82</u>

For cleaning up the two presses, twice a month, it requires the services of four men for one shift of eight hours, or \$256 for eight months.

SUMMARY.

	Per ton of solution precipitated.	Per ton of ore treated.	Per oz. fine metals recovered.
Cost of precipitating ...	\$0.0430	\$0.1190	\$0.01400
Cost of cleaning up	0.0026	0.0073	0.00086
Totals	\$0.0456	\$0.1263	\$0.01486

The efficiency of the precipitation is shown by the following figures, giving average assays in the precipitation of 95,657 tons of solution :

	Heads, gold oz. per ton.	Tailing, gold oz. per ton.	Heads, silver oz. per ton.	Tailing, silver oz. per ton.
Strong solution	0.0352	0.00149	3.39	0.0605
Mill or weak solution	0.0290	0.00216	2.80	0.1590*

*Excepting the month of March, 1908, when, owing to a series of break-ages in a poor quality of twill-filters, the tailing from weak-solution precipitation averaged 0.58 oz. silver, this average stands 0.058 ounces.

For these eight months the check between the recovery indicated by solution-assays and the actual recovery from the presses is shown in the following :

	Gold, fine oz.	Silver, fine oz.
Indicated recovery by solution-assays..	2,986.31	290,715.36
Actual recovery from presses.....	3,170.28	291,868.98

During the same period the average consumption of zinc-dust was as follows :

	Lb.
Consumed per ton of ore treated.....	0.970
Consumed per ton of solution precipitated.....	0.350
Consumed per ounce of metals precipitated.....	0.115

The total fineness of the precipitate, as taken from the presses, has ranged between 414 and 688, the average for the eight months being 517, or 51.7% precious metals. This product ranges between 12 and 20% zinc-content, and 10 and 15% silica. The presence of the latter ingredient is due to the extreme difficulty of completely clarifying the mill-solution before precipitation. To the eye these solutions appear perfectly clear, but they carry a small amount of solid matter, which is caught in the precipitation presses. A preliminary filtering system is now being installed, which will eliminate a great part of the silica and considerably improve the grade of precipitate.

The cost of tube-milling from October 1, 1907, to June 1, 1908, works out as shown below. A 4-in. lining lasted from August 20, 1907, to April 20, 1908, or exactly eight months. During that time 31,835 tons was crushed by stamps, and 68% of this, or 21,511 tons, was re-ground.

Cost of power: 85 hp. for two mills, at \$8, or \$5400 in eight months.

Pebbles: 70,860 lb., at \$50 per ton, or \$1770 in eight months.

Silex lining: cost for two mills, using imported cement at \$12.48 per bbl., \$2216.92.

Labor: one-half of one man's time on each shift, at \$4, \$1440 in eight months.

Maintenance and repairs: on mills and Dorr classifiers, \$79 per month, or \$632 in eight months.

SUMMARY OF COST PER TON OF ORE STAMPED.

Power	\$0.170
Pebbles	0.055
Lining	0.069
Labor	0.045
Maintenance and repairs.....	0.019
	<hr/>
	\$0.358

Consumption of pebbles: 2.22 lb. per ton of ore stamped, or 3.29 lb. per ton of ore re-ground.

The following details on cost of re-lining one of the tube-mills may be of interest:

2500 silex bricks, at \$0.302 per brick.....	\$ 756.27
1 mason, 8 days, at \$8 per day, lining mill.....	64.00
*1 mason, 10 days, at \$8 per day, chipping bricks....	80.00
2 helpers, 10 days, at \$4.....	80.00
10.75 bbl. 'Heidelberg' cement, at \$12.48 per bbl.....	134.16
Sharpening tools	2.03
	<hr/>
	\$1,116.46

*This lining was composed of 2½-in. blocks set on edge to make a 4-in. lining, as there happened to be a large stock of the thinner bricks on hand. This made the lining unusually expensive. The mill was shut down 13 days for re-lining. The old lining wore down unevenly, being less worn at the tail-end of mill. The average thickness when chiseled off from the shell, was about ¼ in. In places the thin cement-bedding had worn down to the shell of the mill.

The cost of filtering by the Butters process for the months of March, April, and May, 1908, was:

Labor: 1 man per shift, at \$4, with occasional extras.

Maintenance and repairs: on filter leaves, filter-boxes, and pumps.

Acid: hydrochloric acid, for washing leaves.

Power: 42 hp. for operating circulating-pump, vacuum-pump, and stirrer in pulp-tank, at \$8 per hp. per month.

SUMMARY.

	Labor.	Maintenance and repairs.	Acid.	Power.
March	\$ 382.50	\$ 6.75	\$165.93	\$ 336.00
April	360.00	259.06	163.43	336.00
May	364.00	142.60	160.43	336.00
	<hr/>	<hr/>	<hr/>	<hr/>
Totals	\$1,106.50	\$408.41	\$489.79	\$1,008.00

Total tonnage for three months, \$13,462.

Average per day filtered, 146 tons.

Labor per ton	\$0.082
Maintenance and repairs.....	0.030
Acid per ton.....	0.036
Power per ton.....	0.082

Per ton of ore filtered..... \$0.230

CONSUMPTION OF CHEMICALS IN CYANIDE PLANT.

Pounds per ton of ore.

	Cyanide.	Zinc.	Lime.	Lead acetate.	Hydrochloric acid.
October, 1907 ...	4.98 KCy	0.91	8.64	*	*
November	2.40 KCy	0.90	7.50	*	*
December	2.09 NaCy	0.81	8.29	0.21	0.14
January, 1908 ..	2.11 KCy	1.19	8.63	0.27	0.19
February	1.80 NaCy	0.76	8.32	0.31	0.33
March	2.05 NaCy	0.96	7.70	0.31	0.39
April	2.48 NaCy	1.14	8.20	0.31	0.40
May	1.98 NaCy	1.10	7.55	0.27	0.40

*None used.

It may be stated that although this mill has made the record on costs for this district, all the costs are in reality high. Water, power, and labor are expensive items, and freight rates are exorbitant. It would therefore be idle to compare these conditions with those obtaining in other countries, as in Mexico, for example. The



Fig. 40. PUMP ROOM, CYANIDE PLANT, MONTANA-TONOPAH MILL

following figures are offered merely to illustrate a few of the difficulties incident to milling operations in Nevada:

	Tonnage treated.	Cost per ton, milling and cyaniding.
October, 1907	4120	\$4.25
November	4410	3.79
December	4256	3.58
January, 1908	4135	3.59
February	4383	3.59
March	4701	3.28
April	4303	4.08
May	4458	3.67

These figures do not include insurance and depreciation on plant.

In explanation of the above costs, the following items may be of interest:

Average cost of water per ton of ore treated	\$0.287
Average cost of power per ton of ore treated	0.808
Average cost of labor per ton of ore treated	0.943
Total	\$2.038

Crusher-men, battery-men, concentrator-men, and solution-men receive \$4.50 per shift of 8 hr.; filter-men, \$4; laborers, \$4; and carpenters, \$6.



Fig. 41. ZINC-DUST PRECIPITATION PRESSES
Showing part of cake in place at time of clean-up

EXTRACTION.

(By concentration and by agitation in cyanide solution.)

	Average.		Average		Extraction		
	mill-head.		tailing,	Butters filter.	by bullion-		
	Gold,	Silver,	Gold,	Silver,	Gold,	Silver,	Total.
	oz.	oz.	oz.	oz.	%	%	%
October, 1907	0.153	15.44	0.0039	2.18	97.55	85.5	88.76
November	0.135	14.97	0.0084	2.36	94.30	84.6	87.40
December	0.133	13.90	0.0080	2.14	94.30	85.4	87.70
January, 1908	0.163	16.34	0.0106	2.41	94.00	86.6	88.50
February	0.186	18.36	0.0105	2.01	93.50	88.0	89.40
March	0.240	23.66	0.0140	3.09	93.80	86.9	88.80
April	0.206	20.20	0.0100	1.64	95.20	89.7	91.10
May	0.219	20.44	0.0129	2.28	93.40	88.6	89.80
June	0.172	16.67	0.0110	1.80	93.40	89.7	90.60

Of this extraction approximately 40% is obtained by concentration, and the remaining 50% by cyanidation.

HOMESTAKE SLIME-PLANT COSTS

(September 12, 1908)

The Editor:

Sir—I enclose tabulated and analyzed Homestake slime-plant

COSTS PER TON IN SLIME TREATMENT AT HOMESTAKE MINE, SOUTH DAKOTA

TOTAL TONS TREATED, 49,946

Item.	Labor.	Electric power and lighting.	Chemicals.		Other supplies.	Total.
			Item.	Cost.		
Thickening	\$0.00370	\$0.00006	\$0.00379
Transportation	0.00030	0.00030
Neutralization	0.00625	\$0.00116	Lime, 4.476 lb.	\$0.02236	0.00006	0.02985
Filling and discharging Merrill sluic- ing presses	0.01040	0.00347	0.00239	0.01626
Dissolving and washing	0.02468	0.01502	Cyanide, 0.31 lb. HCl Zinc, 0.127 lb.	0.06200	0.00014	0.01126
Precipitation (Merrill method)	0.00281	0.02324	*0.01000	0.13508
Heating	0.00218	0.00762	*0.00057	0.01126
Assay office	0.00348	0.00537	0.00755
Superintendence	0.00911	0.00518	0.00866
Miscellaneous	0.01272	0.00043	0.00954
Fire protection	0.00117	0.01389
Refining, bullion expressage, and mint charges	0.00054	0.00054
Total	\$0.07533	\$0.01965	0.00864	0.00864
*Cloths.	\$0.11524	\$0.03511	\$0.24533

The costs of supplies applying above are as follows: Hydrochloric acid, \$4.30 per carboy—10 carboys per press; cyanide, 20c. per lb.; lime, 0.005c. per lb.; zinc, 0.06c. per lb.; labor, \$3+ per 8-hr. shift; power, \$7.50 per mechanical horse-power per month. One suit of filter-cloths lasts one year; for 24 presses, cloth-consumption is two suits per month, or 1c. per ton of slime treated.

operating costs for the month of March, 1908, which was a typical month. I trust it may prove of interest to your readers.

Two more presses are now being added to the plant, and grading will begin shortly for several more in order to take care of the larger proportion of fine which will result from the operation of the fine-grinding plant now in process of installation.

C. W. MERRILL.

San Francisco, August 14.

AGITATION BY COMPRESSED AIR

By F. C. BROWN

(September 26, 1908)

Now that the method of agitation in tall tanks has been adopted by many progressive companies, the following notes on New Zealand experience will be appropriate. The tanks go under the name of the 'B. & M.' tanks (Brown & McMiken) in New Zealand and Australia, the 'Pachuca' tank in Mexico and the United States, and Brown's circulating-tank in other countries. In appearance they are cylindrical, but internally they consist of a large cylinder terminating in a cone of 60° slope. The weight of the tank and its content is transmitted by the continuation of the cylindrical shell, stiffened by horizontal angle-bars to a heavy angle resting upon a concrete foundation, as shown in Fig. 43, which represents the tank in sectional elevation. The lower end of the cone is closed by a heavy cast-iron bottom, which rests upon a concrete foundation and takes a portion of the weight of the tank. A doorway in the lower part of the shell gives access to the space around the cone, and a manhole in the latter facilitates inspection of the valves when the tank is empty. The discharge of the contents, after agitation, takes place through a pipe near the bottom, provided with a valve or cock. In the centre of the tank there is a large pipe held vertically in position and open at both ends, the lower end reaching to within about 18 in. of the bottom of the cone, and the upper end terminating about 18 in. from the top of the tank. Means are provided for admitting compressed air into the lower end of this pipe in the same manner as with an air-lift.

Tanks large enough to treat charges of 125 tons are now in successful operation, and there is no reason why even larger ones should not be used. In Fig. 43 is shown the style of tank used at the Grand Junction mine, Waihi (13 ft. diam. by 55 ft. deep), complete with its internal fittings, and standing on its foundation, which consists of a ring of concrete, with a square block of concrete in the centre to support the casting at the bottom of the tank.

Fig. 44 shows the arrangement of jets for a very large tank, or for one in which it is required to treat concentrate or sandy material. There is an opening in the stand of the tank about 3 ft. 6 in. high by 2 ft. wide (*Z*, Fig. 43), and opposite this there is a manhole (*M*, Fig. 43). The cone is finished off with a heavy casting

(*J*, Fig. 44) and has a discharge cock, *K*. *B* is the central pipe, *C* the outer air-pipe with a rubber valve, *H*, at its lower end, *D* the inner air-pipe with a rubber valve, *G*, at its lower end, and *E*, the pipe to supply the solution, water, or air to the distributor, *F*, which discharges through the pipes *I* and *I'*, fitted with rubber valves (Fig. 43 and 44). Pipes *C*, *D*, and *E* are supplied with air from pipe *O*, and with water or solution from pipe *N*, with the arrangement of valves as shown. There is a circular piece of iron plate serving as a splash-cover to the central pipe *B*, and this is fastened to the pipe *D* in such a manner that its height can be adjusted. *P* is the pipe to supply the slime or battery pulp. This pipe, *P*, branches into two pipes, *P P*, which are carried along the two rows of tanks. The air and solution pipes are arranged in the same way. *R* is a platform which runs between two rows of tanks, and from this all the valves can be readily reached. There is a hose attached to a pipe, which goes direct to the filters. This hose is used for discharging all the tanks, as they are discharged one at a time, and can be moved from one to the other.

The method of operation is very simple. The tank being filled with ground ore and solution, air is admitted through the pipe *D*, which, mixing with the pulp in the central pipe *B*, lightens the column inside and causes it to overflow, while fresh pulp is drawn in at the bottom, and is in turn brought to the top, thus producing a perfect circulation, which is kept up as long as the supply of air is admitted. Should the pulp have settled, or should it become firmly packed at the lower end of the air-lift, solution or air, or a mixture of both, is forced in through the jets *I* branching from the distributor *F*, with the result that the pulp is softened and is readily lifted through the central pipe. The initial air-pressure has to exceed that of the column in the air-lift, but when circulation has been established the pressure can be considerably reduced. The conditions for cyanide treatment are perfect, since every particle of the ore is constantly coming into contact with the solution and air as they enter the bottom of the air-lift. Sand can be treated as readily as slime, and there is no danger from interruption of the motive power, so disastrous in mechanical agitation when sandy material is being treated, as, even after weeks of standing, the contents of the tank can be readily started up, and in less than an hour the whole charge be brought into perfect circulation.

The first large tank was erected early in 1902 at the Komata Reefs Co.'s battery, at Komata, New Zealand. Its dimensions were 7 ft. 6 in. diam. by 37 ft. high, including the cone, the angle of slope of which was 55°. Before deciding to erect this, numerous experiments had been made in a small testing tank of 20 in. diam. and 8 ft. high, and the results were highly satisfactory. Later on in the same year two larger tanks were erected, their dimensions being 10 ft. diam. by 39 ft. high. These tanks were used for treating slime, and, owing to their great depth, were found to be excellent for the final settling of slime in the decantation process, as they made it possible to decant a large percentage of the solution

before finally discharging the treated material. These first tanks were not arranged with the large central pipe and jets for flushing the cone, and it was not until these important features were introduced early in 1904, that the tall tank became an all-round practical ap-

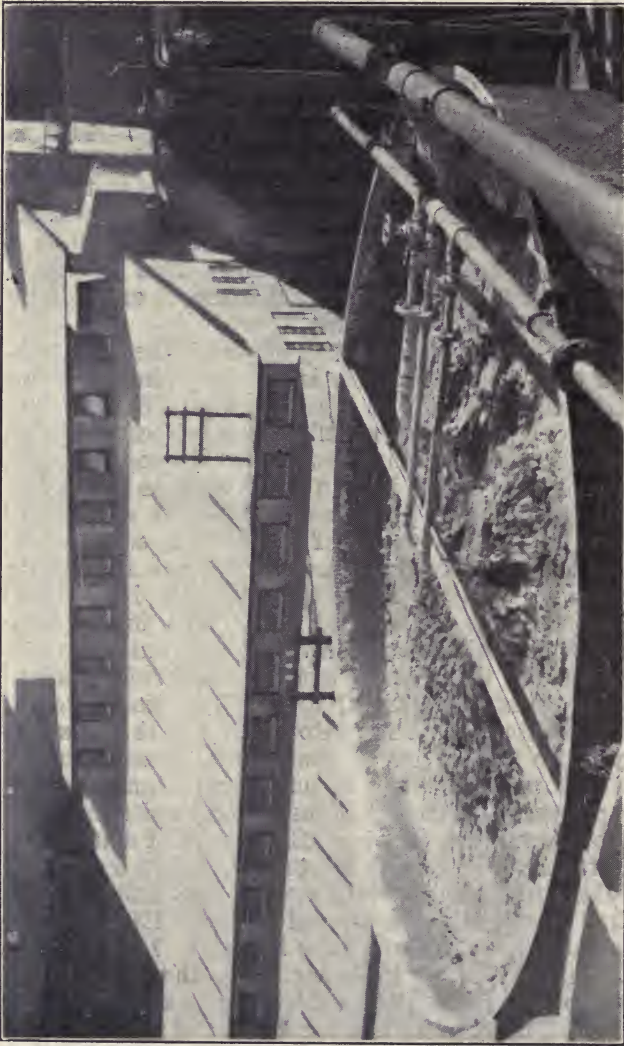

Fig. 42. SLIME IN AGITATION, TOP OF TALL TANK

paratus for the agitation of battery pulp, fine concentrate, and slime. In 1903 an attempt was made to agitate finely ground sand (93% through 200 mesh) in tanks 10 by 39 ft., without the central pipe, but it was found that, although the agitation from the top of the tank appeared to be quite violent and efficient, the com-

pressed air was working its way up through the body of the fine sand without properly agitating and mixing it. Samples of solution taken at different depths in the tank showed different values, and it was found that a large quantity of sand adhered to the sides of the cone at the bottom of the tank and was not agitated at all. The introduction of the central pipe and the arrangement of jets for sluicing the sides of the cone with compressed air or solution during agitation, made the tank a success, and it is now, without doubt, the simplest and most perfect agitator known. Seeing that ore-treatment by the cyanide process is becoming a matter of very fine grinding and agitation of the whole product as 'slime,' an agitator that does its work properly, has no wearing parts, and never goes wrong, will be appreciated by millmen.

The evolution of the tall tank as an agitator did not come without effort. Like most good things, it required thought, experiment, and money. As already stated, it was first used at Komata, and S. D. McMiken, the battery superintendent, did good work in assisting to make it a success. Later on, when the central pipe was introduced, J. R. Noble and J. A. Thomson, of Waihi, gave valuable suggestions. Now that the tank is perfected, it seems very simple.

In treating very fine material, such as slime, a comparatively short tank will do good work, but as a general rule it is advisable to have the height about $4\frac{1}{2}$ to 5 times the diameter, and height is especially necessary when it is required to treat coarse material or concentrate. It is economy to build the tanks high, as the same size of air-compressor, working at a slightly higher pressure, will supply air for a larger tonnage of ore; also because the cone, stand, and fittings remain the same, irrespective of height. It has also been found that the higher the tank compared with the diameter, the less is the power required for agitation, and tests show that the consumption of cyanide is less in high tanks than in low ones, due to the fact that with high tanks the quantity of compressed air per ton of ore is less than with short ones, though its pressure is greater. The diameter of the central pipe should be about $1\frac{1}{4}$ in. for each foot of diameter of the tank.

The following figures relating to the air and power required are from actual working conditions extending over long periods, ranging from 6 to 18 months:

1. A tank 7 ft. 6 in. diam. by 37 ft. was used for treating slime, and required from 4 to 6 cu. ft. of free air per minute, at a pressure of 22 lb. per square inch. The charge of slime was 15 tons (dry weight), and the horse-power was from one-third to one-half.

2. The same size of tank, treating finely ground concentrate, requires 15 to 20 cu. ft. of free air per minute, at a pressure of about 26 lb. per square inch; this quantity of air gives a thorough agitation with a charge of concentrate of 35 to 40 tons (dry weight), with $1\frac{1}{2}$ to 2 horse-power.

3. An installation of 10 tanks, each 10 by 39 ft., treating slime, requires 88 cu. ft. of free air per minute, at a pressure of

23 lb. per square inch. Each tank holds a charge of 35 tons (dry weight), and requires $\frac{3}{4}$ hp. per tank.

4. Two tanks, 13 by 55 ft., treating slime, require 32 cu. ft. of free air at a pressure of 33 lb. Each tank holds 110 tons dry slime. The horse-power consumed is $1\frac{3}{4}$ per tank.

When I first commenced experimenting with these tanks the probable heavy consumption of cyanide due to the action of the air used for agitation was held by some to be opposed to their success. The installation of 10 tanks, each 10 by 39 ft., at the Komata battery has been in operation for 18 months, and although there has been no opportunity for actually comparing them with the usual shallow agitator, it has been found that the consumption of cyanide is very small. At the Grand Junction mine (Waihi) are three different types of agitators, the usual shallow agitator, tall tanks, and a shallow agitator operated by a high-speed screw-propeller, and careful tests have been made, with the result that it has been proved that the consumption of sodium cyanide by slime treated in the shallow mechanically operated agitators during a period of over two months has averaged 2.6 lb. per ton. The consumption by slime treated in tall tanks (13 by 55 ft.) during the same period averaged 2.4 lb. sodium cyanide per ton. Expressed in terms of potassium cyanide these consumptions work out at 3.38 lb. per ton in the shallow agitators, and 3.12 lb. in the tall tanks. The consumption of sodium cyanide by concentrate treated during a period of two months in the agitator operated by a screw-propeller was 3.1 lb. per ton, while those treated in the tall tanks (7 ft. 6 in. by 37 ft.) during the same period consumed only 2.4 lb. per ton. These consumptions expressed in terms of potassium cyanide are, 4 lb. per ton in the shallow agitator and 3.1 lb. in the tall tanks. Potassium cyanide is now being substituted for sodium at the Grand Junction mine, as it is found that the former stands the action of the air better, and will effect a considerable economy.

It is not claimed for the tall tank that it increases the extraction. It is simply a perfect agitator—a statement which cannot be correctly applied to many of the shallow types of agitators at present in use. At the Grand Junction mine, tall tanks compared with the screw-propeller shallow agitator in treating concentrate shows identical results as far as extraction is concerned, but compared with the shallow agitators with arm stirrers in treating slime they give tailing which averages 10d. lower per ton. These tanks are installed at the following properties, namely, Komata Reefs Co., which was the first to adopt them, having a battery of 10 tanks, 10 by 39 ft., treating slime; the Waihi Gold-Mining Co., 23 tanks, 6 by 15 ft., treating concentrate, and 32 tanks, 12 by 38 ft., treating slime; the Waihi Grand Junction Co., 6 tanks, 13 by 55 ft., treating slime, 6 more under construction, and 4 of 7 ft. 6 in. by 37 ft. for concentrate; and the Waihi-Paeroa Gold Extraction Co., with 9 tanks, 10 by 39 ft., treating finely ground sand.

The importance of this agitator in the Waihi and neighboring districts can be readily understood when the nature of the ore is

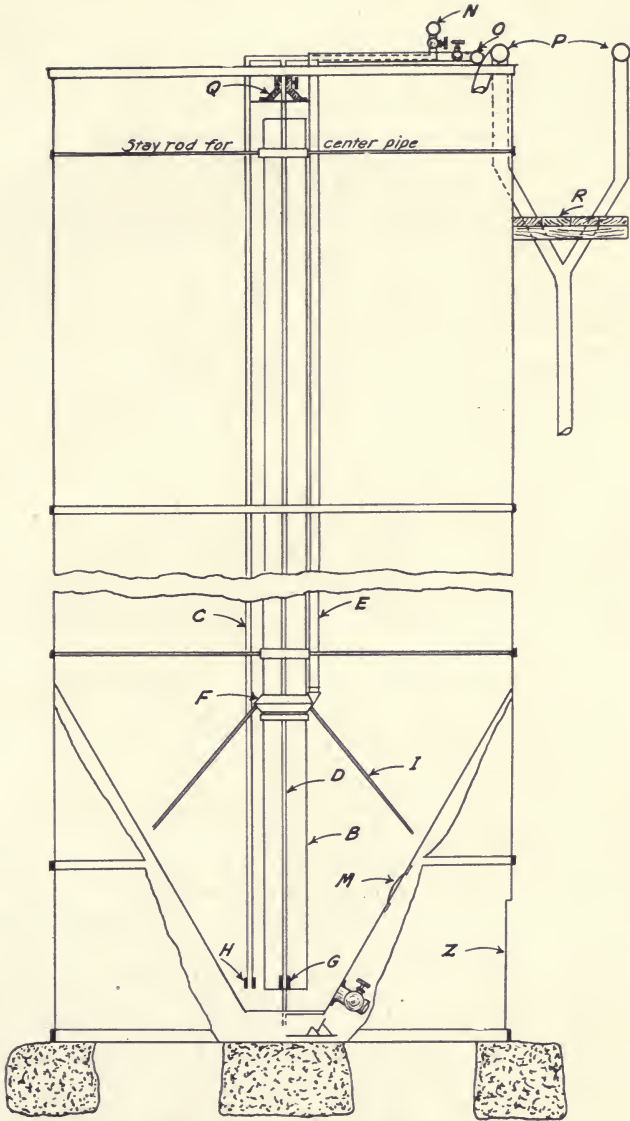

FIG. 43

taken into consideration. It consists of a quartz-gangue with some calcite, iron pyrite, galena, and zinc blende, throughout which the gold and silver are exceedingly finely disseminated, the former occurring chiefly as an alloy with silver in about equal proportions, and the latter as mixed sulphides of silver. The proportion of gold and silver in the ore is about one part by weight of gold to six of silver. If a high extraction is aimed at the ore has to be ground

to the finest possible pulp and kept in agitation with a fairly strong cyanide solution (about 0.3%) for a period ranging from five to eight days. The concentrate, constituting 8% of the ore at the Grand Junction mine, before being re-ground will all pass a 200-mesh sieve, and the aim of the re-grinding, which is done in a tube-mill, is to bring it to such a fineness that it will pass a silk cloth corresponding to what would be a 400-mesh sieve. This degree of grinding can be brought about if collected concentrate be ground

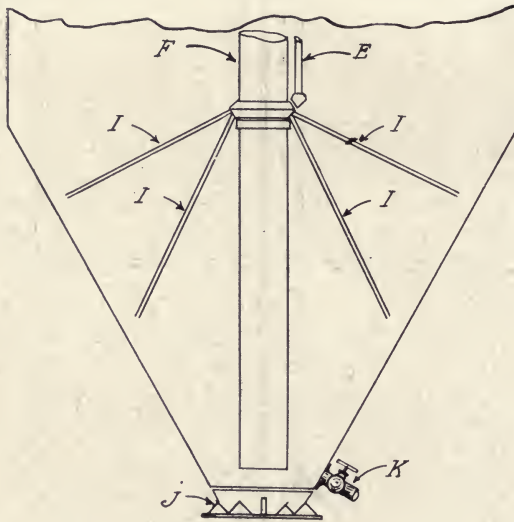

FIG. 44

in connection with about 25% of 10-mesh sand, which latter is, by a special separating device, taken from the battery launder. The re-ground concentrate is then agitated in tanks $7\frac{1}{2}$ by 37 ft., holding 40 tons each, for a period of 12 days in 0.4% KCy solution. The value of the concentrate will average £11 per ton before treatment, and the residue comes out at 17 shillings per ton, equivalent to an extraction of 92.3%. This is the average extraction at the Grand Junction mine for the past nine months, where 300 tons of concentrate per month, obtained from 4000 tons of ore, is treated.

CONTINUOUS VACUUM-FILTER MACHINE

By BERTRAM HUNT

(September 26, 1908)

In an effort to produce an efficient continuous filtration device for use in cyaniding slime, I designed a vacuum-filter, which contains features that promise high efficiency. The machine may have a stationary filter-bed or a revolving filter-bed. In the first form, the filter-bed is an annular chamber, the top of which constitutes the filtering surface. The filter used is a form of sand-filter which

I first applied over fifteen years ago, and has been used most successfully in leaching gold-slime.

In making the filter-bed, slats of triangular section are placed side by side but not touching, a space of about one-quarter or three-eighths of an inch being left between the bases of the slats. Carefully screened gravel, as nearly uniform in size as possible and too large to pass through the openings between the bases of the slats, is then placed in the lower part of the bed. Above this finer gravel or coarse sand is spread in a layer about 1 in. deep to form a floor on which is spread clean sand of 8 to 12-mesh size, to a thickness of an inch or so above the tops of the triangular slats. This forms the permanent filter-bed and is supported strongly enough to remain perfectly rigid on the application of a vacuum in the chamber underneath. This chamber is connected with a wet-vacuum pump or other machine which withdraws the solution and maintains the vacuum.

The walls of the structure may be made of concrete, and these being raised a couple of inches above the top of the filter-bed constitute circular tracks on which a carriage revolves. This carriage has an iron scraper in front, which is of the same width as the filter-bed, and removes the layer of residue from the permanent filter-bed. The residue is removed from the scraper by a screw-conveyor, or by sluicing when water is available for that purpose, and is carried to the hollow central pillar of the machine from which it is carried outside by a conveyor or by water.

Following close behind the scraper, on the carriage, is placed a distributor similar to that used on a Frue vanner, which distributes the sandy portion of the pulp. Behind this is a second distributor which spreads the slimy portion of the pulp over the layer of sand just laid down by the first distributor. On the central column of the machine are two concentric hoppers or funnels, which are connected by pipes with the two distributors, and which receive the pulp. Before reaching the filter-machine the pulp is roughly classified, so that a portion of the sand is separated in a clean condition, and this clean sand is fed upon the filter-bed by the first distributor, the rest of the pulp going to the second. In this way the slimy portion of the pulp is always distributed over a layer of clean fine sand. As the carriage moves continuously the deposited layer of sand and slime is also continuously removed by the scraper, while fresh material is deposited by the distributors, as described above. Pipes to spray wash-solution or wash-water follow the carriage at suitable distances, so that the residue can be thoroughly washed.

When it is desirable to keep the strong solutions separate from the weak, the vacuum-chamber underneath the filter-bed is divided by partitions into a number of sections, the outlet from each section being equipped with suitably connected valves. These valves would be operated automatically so as to discharge the strong solution separately from the weak. Such an arrangement is an added complication, and in the majority of cases proves to be un-

necessary. In the case of a plant in which leaching is done by percolation in vats it is easy and usually desirable to keep the strong and weak solutions apart, but in a modern plant practising fine grinding and agitation, followed by mechanical filtration, the conditions are quite different. A machine which has to run continuously should be as simple and as nearly valveless as possible. In those instances in which it is desirable to keep the strong solution separate, two filter machines should be worked tandem, the strong solution being withdrawn from the first, and the washings from the second.

The machine illustrated herewith has an extreme diameter of 15 ft., the annulus being 3 ft. wide. This gives a filter-surface of 113 sq. ft. On the supposition that the layer of residue contains 50% moisture and weighs 109 lb. per cubic foot, if it is $\frac{1}{4}$ in. thick, it will amount to 2.26 cu. ft., and will weigh 246 lb., or 123 lb. dry. At a speed of one revolution of the carriage per minute this represents an output of 3.69 tons of dry material per hour, or over 80 tons per day. I have taken 50 tons per day as my estimate of the net capacity of this size of machine.

A great deal has been published recently regarding the troubles incidental to the use of canvas or filter-cloth in filter-presses and vacuum-filter machines. The cost of repairs and renewals is large, and there is a necessity for periodical soaking in hydrochloric acid to remove the incrustation of lime salts, and for the employment of a subsidiary filter to clarify the solutions. With a sand-filter properly arranged these troubles do not exist. A clear filtrate is always obtained, and no subsidiary filter is required. This means a considerable saving in itself, and the elimination of the acid-treatment means a further economy as compared with canvas filters. Whenever it is desirable to clean the permanent filter-bed, the scraper, which is adjustable, is lowered, and the carriage revolved so as to remove the layer of sand above the tops of the triangular slats. Clean sand is then spread over the surface to the proper depth, the scraper is adjusted, and the machine is at once ready for work again. Little appears to have been done in the use of sand for filtering in hydro-metallurgical work. Possibly the reason has been in the difficulty of preserving a thin layer of sand without disturbing or washing it away. The distribution of a thin layer of slimy material on the top of a layer of sand from a slowly moving carriage with the consequent minimum disturbance of the sand layer, forms an ideal condition for rapid filtration. A continuous machine has many advantages in operation. The load on the machine is steady, and the attendance required is small. A filter-machine of the size illustrated will require less than one horse-power to drive it, and four horse-power to maintain the vacuum. When a continuous filter-machine has been regulated as to the amount of feed, the rate of revolution of the carriage, and the speed of the vacuum-pump, it is practically automatic in operation, and the only attention required is to keep the bearings oiled. With vertical filter-surfaces only very fine material can be treated to give

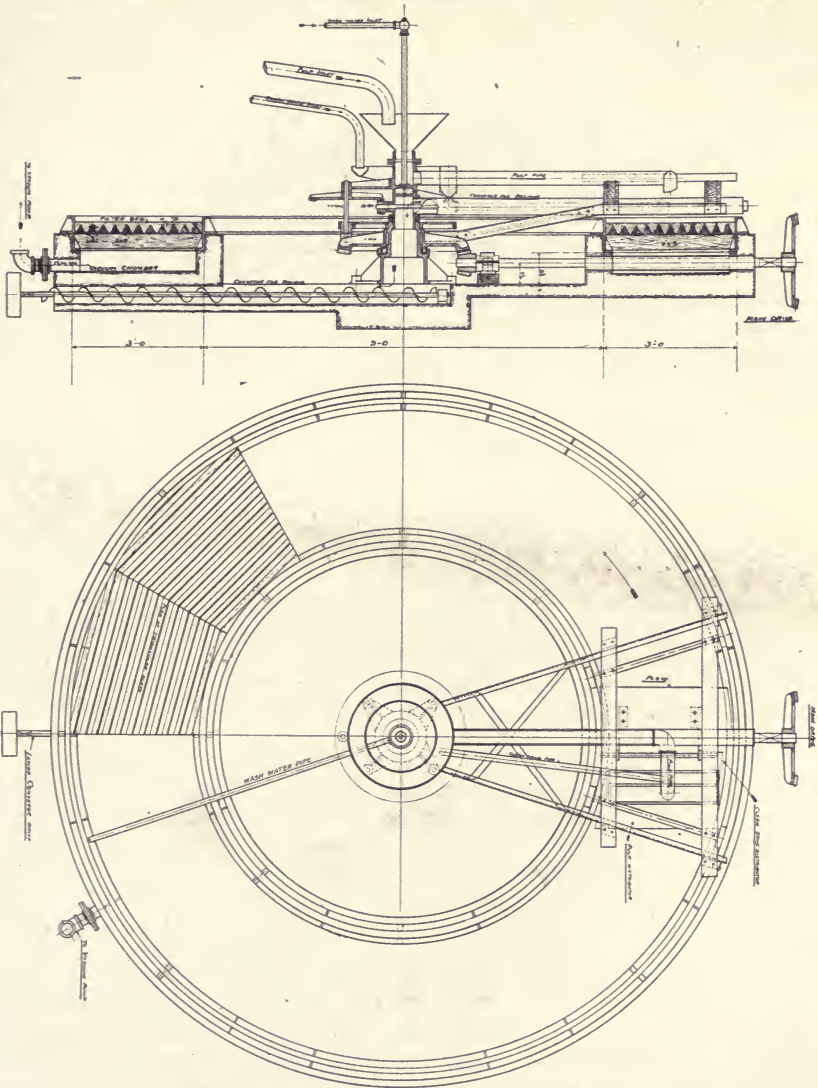

Fig. 45. HUNT CONTINUOUS FILTER

a cake that is uniformly permeable. As these machines all work intermittently a considerable thickness has to be accumulated on the surface of the filter-bed to form one charge, and consequently the efficiency of the filtration is progressively impaired and becomes slower and slower from the commencement to the completion of the cake. With a horizontal filter, working in unison with gravity, very coarse or very fine material, or both together, can be handled efficiently.

Further, by depositing the material to be filtered in a very

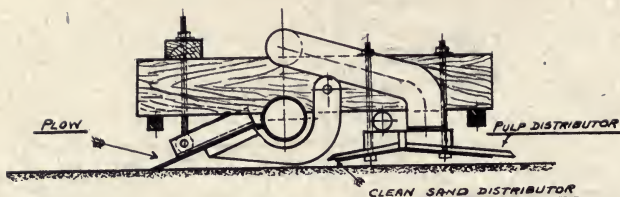

Fig. 46. DETAIL OF CARRIAGE

thin layer on a horizontal filtering surface of sand, the removal of the solution and the washing are done nearly instantaneously, and the continuous removal of the residue and the deposition of fresh material makes the efficiency constant.

RECENT CYANIDE PRACTICE IN KOREA

By A. E. DRUCKER

(October 3, 1908)

The Oriental Consolidated Mining Co., with works situated in northwestern Korea, is now operating a total of 220 stamps, crushing about 30,000 tons of low-grade ore per month. There are five stamp-mills and four cyanide plants, scattered over the concession, using different methods of cyanide treatment, the most recent being the method employed at the Candlestick mill. The cyanide practice here is somewhat unusual and a detailed description may prove interesting.

At Candlestick the company has a small mine that will produce 20 to 30 tons of \$20 ore per day. The ore consists mainly of quartz, and contains from 10 to 20% of sulphides, including iron pyrite, zinc blende, and galena. Unlike the other ores on the concession, there are no serious obstacles to cyanide treatment, such as the presence of arsenical pyrite, marcasite, and stibnite. The former two oxidize readily in moist air with the formation of ferrous sulphate, which decomposes cyanide, and also acts as a de-oxidizer, absorbing oxygen from the cyanide solutions. The ore is free-milling to a large extent (70 to 75% of the gold being amalgamated on silvered copper-plates). The greater part of the gold, however, is in a fine condition. There is an abundant supply of water for milling purposes throughout the year. Power is an inexpensive item, for both wood and water are plentiful, and close at hand.

After performing experiments on a practical scale at the Taracol test-plant I decided that the most economical form of treatment for such an ore would be to crush with stamps, and use inside and outside plate-amalgamation, followed by direct cyanide agitation of the total tailing, with decantation and vacuum-filtering. Preliminary concentration before cyanidation is omitted.

The mill consists of one 7 by 10-in. Blake crusher, 10 stamps weighing 1050 lb. each, and two standard 10-ft. silvered copper-plates in three sections, with drops of 1¼-in., and a grade of 3 in. to 1 ft. For inside amalgamation there are two plates, both back

plate and chuck-block. Also there is included a clean-up pan, and all necessary appliances that go to make up a modern 10-stamp mill. Concrete mortar-blocks, built on solid granite, constitute the battery foundations. All anchor-bolts are so arranged that at any time a broken one may be readily removed, and a new one substituted.

The cyanide annex consists of four pyramidal pulp-thickeners, 7 by 7 by 5 ft., four mechanical agitators with plow-shoes, and vacuum-filters, 10 by 15 ft. diam., four sand-filter clarifying tanks, 6 by 12 ft. diam., six 8-compartment zinc-boxes, and three sumps, 10 by 15 ft. diam. There are three separate pumps, one for aerating, another for vacuum-filtering, and a third for pumping solutions. For the clean-up there is one small acid dissolving-tank, 5 by 3 ft. diam., with hood for disposing of short-zinc, one vacuum-filter precipitate-box, 6 by 7 by 5 ft., and one wash-water settling-tank, 6 by 8 ft. diam. In addition to the above equipment there is a separate room for retorting, melting, and roasting. A small assay and chemical laboratory is also supplied.

The ore on arriving at the mill is weighed, sampled, and dumped onto a grizzly, the undersize passing to the bin, the oversize to the Blake crusher. It is intended that the ore as it is fed to the mortars shall pass a 1-in. ring. For crushing and inside-amalgamation we are using a 50-mesh diagonal burr-slot screen. These are of a special 'Duro' steel, and are proving very satisfactory. An 8 to 10-in. discharge, and 8-in. drop, is used at 95 drops per minute. The inside (chuck and back) copper-plates are $\frac{1}{4}$ in. thick. The pulp on discharging from the mortar drops onto a copper splash-plate, and thence onto the lip. From the lip-plate is a drop of 2 in. to the main plate, which is cut in equal sections with $1\frac{1}{4}$ -in. drop to each. I find that a 4 by 8 by 10-ft. plate, cut into three equal pieces, is easily taken up and prepared for silver-plating. The splash-lip and outside plates were given a good heavy plating of $2\frac{1}{2}$ to 3 oz. silver per square foot at our plating plant. The $1\frac{1}{4}$ -in. drops on the outside plates are the proper thing, for at these places are the main accumulations of amalgam. These plates when newly plated were 'spongy' (not too compact), and absorbed a large amount of quicksilver at the first dressing. It would take some little time before the plating would cease absorbing the mercury. The slightly rough surface seems to greatly benefit the amalgamation. A hard compact plating, such as that on tableware, will not absorb nearly the amount of quicksilver, and does not give as good an amalgamating surface. Plates are dressed four times during 24 hr., no cyanide being used. The amalgam on the lower plates is kept at the consistence of putty, while at the splash and lip it is a little harder. 'Quick' is fed every hour to the mortar, the amount being regulated by the richness of the ore. Naturally the lip serves as an indication of what is being done inside, and also acts as a guide to the proper amount of mercury to feed. Both plates are adjustable to grade and we find, with this ore, about 3 to 4 in. to 1 ft. about right. There is a trap at the end of each table.

The stamp-duty is $2\frac{1}{2}$ tons per 24 hr. Amalgamation at the present time on this ore gives a saving of 60% inside the mortar, and 15% on the outside plates, a total saving of about 75% of the gold with \$20 ore.

The pulp from the plates passes directly to three pulp-thickeners. The clear overflow either flows to waste, or is saved when water is scarce for milling purposes, and the thick underflow passes to an agitator.

The thickened pulp discharges from a $\frac{1}{4}$ -in. outlet, the pressure-head being 30 in., and the pulp can be diverted to any of the four agitators by a simple slide-adjustment in the launders. At the battery the consistence of the pulp is about 1 to 7, which gives the best results in the pulp-thickeners when a 1 to 3 pulp is required for the agitators. The thickeners are adjusted so as to take about 12 to 14 hr. to fill one 15-ft. agitator 8 ft. deep. When an agitator is full it contains a charge of about 12 to 15 tons of pulp. While filling, the muller is kept in motion, so as uniformly to distribute the pulp, and if it should be desired to thicken the charge within the agitator so as to make room for a larger charge without stopping the agitator and decanting water, then, while in motion, clear water can be drawn from beneath the filter and run to waste. After the agitator has received a full charge, the agitation is stopped, the muller is raised above the settled pulp, and all allowed to settle for 5 hr. However, before stopping the agitator, 8 lb. lime per ton of ore, mixed with hot water, is added to a 12-ton charge and thoroughly stirred for a few minutes. Lime mixed with hot water forms a milk-of-lime, and is very effective for settling purposes. Decantation takes place as soon as the pulp begins to settle, and I find that time is gained by following the pulp down as fast as it settles. It will take longer for a charge to settle if one waits 3 or 4 hr. before starting to decant. Upon completing this operation and at the end of five hours the settled pulp should contain about 40% moisture. Next the muller is lowered and set in motion until the plow-shoes barely scrape the filter, and at this point the muller is clamped, the vacuum applied beneath the filter, and the charge allowed to filter for two hours. When the vacuum-filtering is complete the pulp will contain from 18 to 20% moisture. What little water remains will not dilute the cyanide solutions to any extent. The charge is now ready for cyanide treatment, which occupies 28 hr. out of a total of 48 required to complete the cycle of treatment.

Strong cyanide solution (0.20% free-double cyanides) is next pumped onto the charge until the agitator is nearly full, while at the same time a muller with plow-shoes is being revolved at 18 r.p.m. The muller is lowered so that the points of the shoes barely touch the filter. Every charge receives a 10-hr. agitation and aeration. When aerating, air is forced beneath the filter and bubbles up through the charge. Aeration and agitation are perfect at every point of the vat. After this operation is finished the agitation is stopped, the air turned off, the muller raised above the settled pulp,

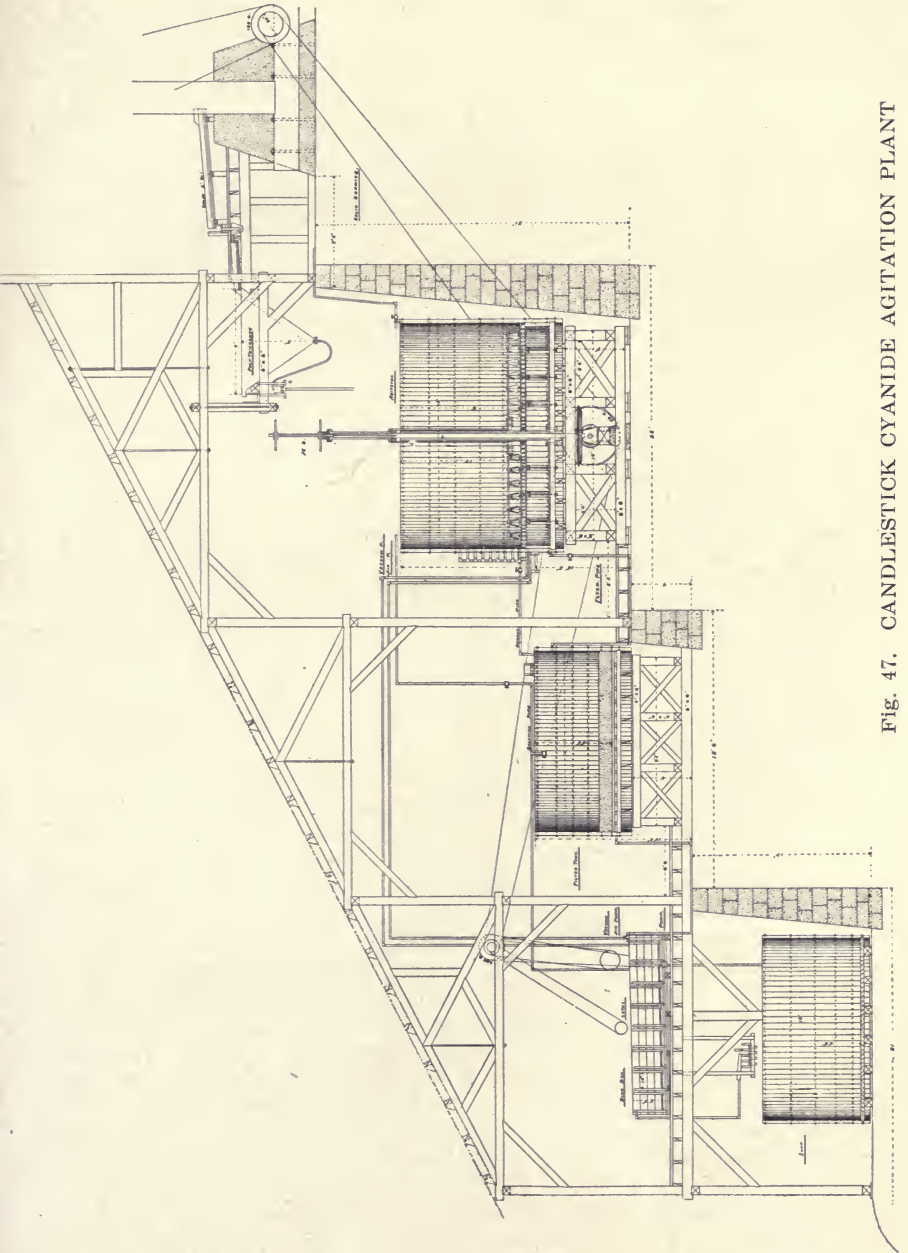

Fig. 47. CANDLESTICK CYANIDE AGITATION PLANT

and all allowed to settle for a short time. The solutions are sufficiently alkaline, and absorb enough lime from the previous operation to cause the pulp to settle readily, therefore no lime is added to any of the washes to follow. Next comes the decanting of the

strong cyanide-gold solution, which can be done to within 40 to 45% moisture remaining with the settled pulp. Decanting begins as soon as possible after the pulp begins to settle and takes about four hours to complete.

It is not necessary to wait until the solution becomes perfectly clear before decanting, since it is run to sand-clarifying vats and from there flows as clear as crystal to the zinc-boxes. These clarifying-vats also serve as gold-solution storage-vats, so that the flow to the zinc-boxes can be regulated. Within each of these vats is a burlap filter and on top of each is one foot of clean coarse quartz sand. If the solution to be decanted is slightly cloudy all the slime therein will form a thin layer on top of the sand, and is removed with a scoop every three or four days. The slime does not seem to penetrate the sand readily. The pulp remaining within the agitator contains from 40 to 45% moisture in rich gold solution and is next vacuum-filtered down to within 20 to 25% moisture. The agitator is set in motion, and the muller gradually lowered through the pulp until the plows just begin to touch the filter. The shoes revolving next to the filter, prevent any slime-cake from forming, and when the suction is started beneath the filter, the gold-bearing solution is gradually sucked through into the compartment below. Before starting the vacuum the slime, containing 45% moisture, is quite thin and agitates readily, there being no trouble in lowering the muller when the plow-shaped shoes are attached. With a good strong suction beneath the filter the time required to bring the charge down to 25% moisture is about two hours. The pulp with 25% moisture is very thick and sluggish toward the last, but it is possible to filter down to 20%. A total of 6 hr. is required for decantation and vacuum-filtering.

After the removal of the strong solution there follows a 0.10% KCy wash, assaying a trace in gold, which is thoroughly agitated for a few minutes, settled, decanted, and vacuum-filtered. Lastly, a weak barren 0.05% is applied in the same way, and upon the completion of this operation the extraction of the gold-bearing solution is practically complete. The charge is now ready to be run to waste. A little water is added, the discharge-hole opened, and the revolving of the muller will empty the agitator. A final wash-water is not necessary and consequently there are no waste solutions of any apparent value. Both washes have their separate storage and clarifying-vats; they are run through their respective precipitation-boxes to corresponding sumps. I find that with the weak wash, precipitation is very unsatisfactory. If much lime is added for settling purposes, a gray coating on the zinc is formed, and in time this entirely prevents a precipitation of the gold. For this reason no lime is added to the washes. Sufficient lime for settling purposes seems to be absorbed from the first addition (8 lb. per ton of dry pulp) or what remains with the pulp after extracting the water. This coating is very hard to remove by simply scrubbing the zinc, and I have found an easy way of removing it is to dip the zinc in a very dilute sulphuric acid bath when required.

The cyanide treatment may be summed up as follows:

	Hours.
Filling	12
Extraction of water from pulp:	
Settling and decanting	5
Vacuum-filtering	2
Cyanide agitation and aeration	10
Extraction of strong solution, 0.20%:	
Settling and decanting	4
Vacuum-filtering	2
Medium wash, 0.10%:	
Settling and decanting	4
Vacuum-filtering	2
Weak wash, 0.05%:	
Settling and decanting	4
Vacuum-filtering	2
Discharging and sampling	1
	—
Total	48

Probably a short explanation of my combined agitator and vacuum-filter would be proper. All details of construction will be found in the figures on pages 192 and 223. The muller has four arms at right angles to each other, and to them are attached 26 cast-iron plow-shoes equally spaced. The shoes on opposite arms are arranged to work in between.

The burlap filter is well braced 24 in. from the bottom, and can neither bulge one way nor the other under pressure or vacuum. As a protection to the burlap one-inch boards bored with inch holes are placed on top and well spiked. The filter-cloth is between, and the holes above should coincide with those below in order to get results. The capacity of this 15-ft. agitator is 12 to 15 tons of dry pulp, and it requires about 5 hp. to run it. The heavy pulp, when once in motion at 18 r.p.m., takes very little power. The muller can be easily raised or lowered 2½ ft. An agitator of this type is particularly adapted to the treatment of the total product from the mill-plates, both sand and slime together. There is never any trouble to start or work down a charge after it has settled compactly. With this arrangement a separate vacuum-filter plant is not needed. All the different operations of collecting, agitating, aerating, decanting, and vacuum-filtering are performed in the one vat, and therefore the method requires a plant of the smallest size. The consumption of cyanide is about 1½ lb. per ton with this heavily mineralized ore; keeping the solutions at 0.20% free KCy plus double cyanide, with a protective alkalinity of about 0.5. The plant has now been in successful operation for several months. The mill-heads average \$20 per ton, the plate tailing \$5, and the cyanide tailing about 60c. gold, or a total extraction of 97%. The total cost of treatment is about \$1.50 per ton, with the prospect of this being somewhat reduced in the future.

BROMO-CYANIDING OF GOLD ORES

• By E. W. NARDIN

(October 24, 1908)

*Although the bromo-cyanide or Diehl process for the extraction of gold from its ores is used at several of the Kalgoorlie mines, little information has been published on the original process, and no details are available from the various mines now using it. The following description of the process as carried on at the Hannan's Star plant, where several modifications were introduced by myself, will therefore be of interest. The process was first installed at the Hannan's Star mine, where a full working plant was erected by the London-Hamburg Co. In the contract 91% extraction on a sulphide ore of 15 dwt. value was guaranteed. This was considered a high extraction at the time, and the plant successfully fulfilled the promise made. The new features in the process were the finer grinding of the ore, for which purpose the tube-mill was introduced, and the addition of a solution of bromo-cyanide to the vats under ordinary cyanide treatment, whereby a higher extraction was obtained in a shorter time. The main difficulty in the process was in the manufacture of the bromo-cyanide solution, which was eventually overcome. The mixed salts now supplied by the London-Hamburg Co. are satisfactory, and are furnished at such a price that the process compares favorably with any other in point of cost.

Most of the Hannan's Star ore which has been treated by the process was low grade, and hence the extraction is low, but the average value of the tailing for 1904 and 1905 was 1 dwt. 2 gr. and 1 dwt., respectively, which must be considered good work. On high-grade ore the process was equally successful. About 15,000 tons from the Brown Hill Extended mine, averaging 4 oz. gold per ton, and containing telluride, were treated by O. B. Ward in 1903, giving an average extraction of 95%. At Hannan's Star the average cost of bromo-cyanide treatment, extending over a period of 12 months (September, 1904, to October, 1905), was 9.75 pence per ton of ore treated, and the extraction was entirely satisfactory. On the same class of ore (sulphide) roasting would cost about 2s. 9d. per ton, so there is a balance of 2s. per ton in favor of the chemical, and the saving of the heavy first cost in furnace plant. In places where fuel and furnace supplies were more expensive, the chemical process would show a much more decided advantage. The process requires more metallurgical skill and constant attention to the progress of each vat under treatment; but, if this is available, the results are highly satisfactory, and the process has definite claim to be a cheap and efficient method of treatment for such ores as the Kalgoorlie sulpho-tellurides.

When I took charge of the Hannan's Star plant in July, 1904, the process was as follows: The ore from the rock-breaker was dry-crushed in two No. 5 Krupp ball-mills, with steel-wire screens of

*Paper in Trans. Australasian Inst. M. E., Vol. XII, 1907.

27 mesh. From the mills it is passed over amalgamated plates to a mixer, and then to a classifier at the end of the tube-mill. Here a separation was made, the overflow going to the slime-pumps, and the underflow into the tube-mill. The discharge from the mill was elevated to the classifier, where separation of the insufficiently ground portion was again effected. The slime-pumps delivered to two sets of spitzluten, the underflow from which passed back to the tube-mill, and the overflow to the pointed settling-boxes, where the pulp was thickened before passing to the agitator-vats. The point aimed at was to slime the whole of the ore to pass a 150-mesh sieve. In practice about 5% would remain on the 150-mesh sieve, but the whole of it would pass the 100-mesh sieve. There were four agitator-vats of 50 tons dry-ore capacity each. These each took on an average 16 hours to fill, representing 75 tons per day through the ball-mills. The tonnage was determined, for working purposes, by weighing the contents of a bottle, filled to its containing mark by dipping into the vat, and by measuring the volume of pulp in the vat. From the volume, tonnage, and specific gravity, the dry weight of ore was obtained. A mechanical sampler was arranged between the balls-mills and the mixer, which cut out a definite quantity periodically. This bulk-sample was quartered down, which gave the ore-sample for the day. A vat when full was given its charge of KCy, and three hours afterward a 'dip' KCy residue was taken, and the charge of BrCy solution added. After a total agitation of 20 hr. a quantity of lime was added, and the vat-charge 'pressed.' The quantity of BrCy added was varied according to the residue of preceding vats, and the value of the ore being treated as shown by the daily ore-sample. Every sixth frame in a filter-press was sampled, and the bulk-sample from the whole vat was quartered down to represent the final residue of that vat. The KCy residue was washed on a small vacuum-filter and assayed, while the final residue was assayed after drying. From the daily ore-samples, KCy, and final residue, the total extraction, and extraction by plain KCy, and by BrCy, were determined.

The bromo-cyanide solution is made according to the following equation:

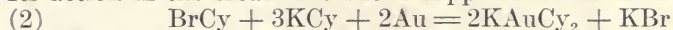
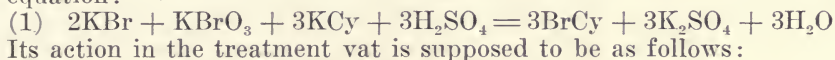

The first two quantities in equation 1 are contained in the mixed salts supplied by the London-Hamburg Co., having about 40 to 44% Br as KBr, and 20 to 22% Br as KBrO₃; the proportion of Br as bromide being about twice that of Br as bromate. A 30-lb. charge is usually made up, and for this the following weights are taken:

	Lb.
H ₂ SO ₄	50.0
KCy	20.0
Mixed salts	36.8

The KCy is 93%, and the H₂SO₄ 63% (chamber acid) strength. The

solution is made in a closed wooden vessel, stirred by rotating arms, holding about 200 gal. In making up a charge, a portion of the water and all the H_2SO_4 are first mixed, and allowed to cool to normal temperature. The KCy, which is dissolved in a separate vessel in sufficient water to fill the mixing vessel, is then run in, and at the same time the proper weight of 'mixed salts' is gradually added. The whole is then agitated for 6 hr. before being used, and in a closed vessel it will retain its strength for some days. The cost of a 30-lb. charge of BrCy is about £4 10s., made up as follows: 50 lb. H_2SO_4 at 2d., 20 lb. KCy at 8.37d., 36.8 lb. salts at 1s. 10d. From each charge mixed, a dip-sample is taken and tested with a standard $Na_2S_2O_3$ solution, using potassium iodide as an indicator.

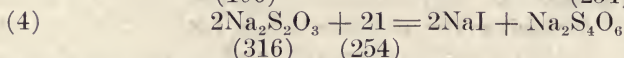
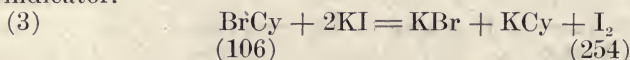

Thus BrCy corresponds to $2Na_2S_2O_3$.

The standard solution is made so that 1 c.c. contains 0.02 BrCy, and for this about 93.6 gm. of ordinary photographic crystals, $Na_2S_2O_3 \cdot 5H_2O$, are dissolved in one litre of water.

(248)

A solution of copper sulphate is used for standardizing the above.

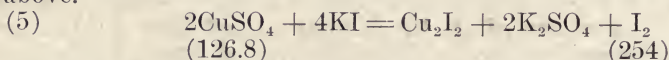

126.8 Cu liberates 254 I, so that it corresponds to 106 BrCy and 496 $Na_2S_2O_3 \cdot 5H_2O$. The solution is made by dissolving one gram of pure copper foil in acid, converting to sulphate, and dissolving in 100 c.c. water. Hence 10 c.c. contains 0.1 gm. Cu, equivalent to 0.0836 BrCy; then 1 c.c. hypo solution corresponds to 0.02 gm. BrCy, and 4.18 hypo solution to 0.0836 gm. BrCy.

In testing BrCy solutions, 5 c.c. are usually taken, Na_2CO_3 solution is added till alkaline, and then acetic acid till acid. A few crystals of KI, and some starch solution, are then added, and the whole titrated with the standard $Na_2S_2O_3$ solution.

Example: If 5 c.c. BrCy solution took 3.2 c.c. hypo, then

$$\frac{3.2 \times 0.0836}{4.18} \times 20 = 1.28\%$$

This method of testing BrCy solutions is different from that used at other mines, where it is customary to titrate direct with $Na_2S_2O_3$ without first neutralizing the H_2SO_4 . The following is a series of tests made on a number of 30-lb. BrCy solutions by direct method, A, and, after neutralizing, B:

Charge.	Lb.	A. %	B. %
668	30	0.36	1.20
670	30	0.44	1.20
671	30	0.60	1.28
672	30	1.20	1.24
673	30	0.36	1.36
674	30	0.52	1.00

These show that by direct titration the test is usually low, and also that it gives irregular results, depending on the amount of free H_2SO_4 present. There seems to have been some doubt as to whether a BrCy solution increases in strength after, say, one hour's agitation, but tests which were made show that it does increase up to about 8 hr., from 0.56 to 1% BrCy. It was generally known that if the solution became too alkaline, either through a change in the ores, or the addition of too much lime either to the ore before crushing or after the bromo-cyanide treatment, the extraction by BrCy fell considerably, and for this reason an occasional test of the plant-solution was made for alkalinity, but not until several high tailing-discharges had been observed. Under the old system the KCy did not have sufficient time by itself; the gold in the ore and the KCy residue of each vat were not known, and the amount of BrCy that should be added was more or less a guess. When it is remembered that every 5 lb. of BrCy added to a 50-ton vat represents a cost of 4d. per ton of ore, that the action of the BrCy can be made just as effective after long KCy treatment, and that excess of BrCy gives no advantage, it will be seen how important it is that the value of the KCy tailing should be known after sufficient agitation (say 12 hr.), and the condition of the vat tested as to alkalinity before adding the BrCy. In any case, the action of the BrCy is of short duration, not exceeding 4 hr., so that if 20 hr. total agitation can be allowed, it is better to give 16 hr. with KCy, and then add the BrCy. It is preferable, however, to keep the vat under KCy treatment until the KCy residue is known, then correct the alkalinity, and add the BrCy. This could easily be done with extra vat-capacity. Total alkalinities are determined with standard solutions of HCl and NaHO, using phenolphthalein as indicator. The following experiments were carried out to determine what was the most suitable degree of alkalinity for bromo-cyaniding.

Six sludge samples were taken at the same time from a vat which had had KCy treatment. The solution was filtered off one, and the quantity of a weak H_2SO_4 solution required to nearly neutralize it was determined. It took 40 c.c., so that to the sludge samples were added the following quantities of H_2SO_4 solution, respectively: to No. 1, 40 c.c.; to No. 2, 35 c.c.; to No. 3, 26 c.c.; to No. 4, 21 c.c.; to No. 5, 14 c.c.; to No. 6, 7 c.c.; to No. 7, *nil*. To each sample was also added 7 c.c. of BrCy solution, and the bottles were sealed and agitated for 8 hr. The solutions were then poured off and tested for alkalinity, while the residues were washed and assayed. The following were the results:

No.	Alkalinity,	Value of Tailing,	
	%	dwt.	gr.
1	0.0096	0	21
2	0.0128	0	21
3	0.0172	1	0
4	0.0262	1	0
5	0.0377	Lost	
6	0.0595	1	3
7	0.0800	1	9

The KCy residue of the vat was 2 dwt., the final 'press' tailing 1 dwt. 9 gr., and the alkalinity of the solution from the KCy residue was 0.08%, and these are included as No. 7 in the above table. From these tests it will be seen that as the alkalinity was reduced so the residues fell in value in almost exact proportion, they prove conclusively that BrCy does not act well in a too alkaline solution, and that the best action is obtained when the alkalinity is from 0.01% to nearly neutral.

A second series of tests, on a different grade of ore (assaying about .14 dwt.) was made. As in the previous case, varying quantities of H_2SO_4 and 7 c.c. of BrCy were added to the bottles, agitated for 12 hr., and the residues washed and assayed.

No.	Alkalinity, Value of Tailing,	
	%	dwt. gr.
1.—Nil	0.0134	1 9
2.—3 c.c. acid	0.0083	1 6
3.—6 c.c. acid	0.0064	1 0
4.—8 c.c. acid	Nearly neutral	1 0

The KCy residue in this vat was 4 dwt. 12 gr., and the final press tailing 1 dwt. 9 gr. It became the practice, therefore, to have the alkalinity of the vats during KCy treatment at between 0.02 and 0.03%, to keep the vat agitated until the value of the KCy residue was known, then correct the alkalinity to about 0.01% or less by H_2SO_4 , and add BrCy according to the assay-value of the KCy residue. A better extraction was thus obtained, at less cost for BrCy, at the expense of a small amount of H_2SO_4 and extra agitation.

Owing to an insufficient number of vats, they could not always be kept back for the KCy residue, but on every occasion on which it was done a certainty could be made of the tailing being low and the consumption of BrCy a minimum. A number of experiments were carried out to explain this reduced action in an alkaline solution, but nothing definite was proved, although it is possibly due to the presence of KHO. If a solution of KHO be added to BrCy it is almost immediately destroyed. No smell of BrCy is left, and no test can be obtained with $Na_2S_2O_3$.

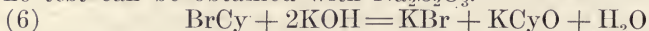

Various experiments were carried out to determine the action of BrCy on FeS_2 and finely divided metallic Fe. The FeS_2 used was panned off from finely crushed ore, while metallic Fe was picked by a magnet from the sludge in a vat. Freshly prepared iron filings were also tried. Small quantities of these were agitated with a previously tested BrCy solution. Action at once began, and in a short time the BrCy was destroyed. All smell of BrCy disappeared, and no test could be obtained from $Na_2S_2O_3$. The result is a greenish-blue solution of a ferrous salt, from which a dark-green ferrous salt is precipitated by NH_4OH . These experiments showed that both FeS_2 and metallic Fe are bromo-cyanicides, that finely divided metallic Fe is the more active, and that there is sufficient of the latter produced in grinding the ore to destroy the amount of BrCy usually

added to a vat. The BrCy seems to act more by breaking up the FeS_2 than by actual solution of the gold, but it is probable that a great portion of it is destroyed by the finely divided metallic Fe, without, of course, any beneficial result as far as setting free or dissolving gold is concerned.

Experiments were carried out to show the effect of adding ordinary commercial lime to vats after BrCy treatment, and it was found that a re-precipitation of gold took place to a small extent. To show this in a magnified way, two samples of solutions, A and B, were taken from a vat after BrCy treatment. Excess of lime was added to A, agitated a few hours, settled, decanted, and assayed, with the following result:

Solution A assayed 3 dwt. 21 gr. per ton;

Solution B assayed 5 dwt. 5 gr. per ton;

showing that the lime precipitated 1 dwt. 8 gr. of gold per ton from solution, or 25%. This is probably due to the presence of carbon or of occluded gases, such as hydrogen.

The results of these experiments have suggested certain improvements in bromo-cyaniding, some of which have been adopted, as follows:

1. The daily ore sample should be taken in the morning, and assayed as soon as possible, so as to know the value of the ore passing to the vats in the previous 24 hours.
2. The pulp should have a long KCy treatment.
3. A vat should be kept under KCy treatment till the value of the KCy residue is known.
4. The alkalinity of the vat should then be determined and corrected to 0.01% by H_2SO_4 before adding BrCy.
5. The quantity of BrCy added should then be determined from the value of the KCy residue, the tonnage of the vat, and so forth.
6. The lime added to the ore during crushing should be varied according to the alkalinity-test after KCy treatment, so that the plant-solution tests about 0.02 per cent.
7. Lime water should be made and added to the vats or to the solution from the presses, instead of adding lime to the vats.
8. Metallic iron should be kept out of the pulp as far as possible, as it is both a cyanicide and bromo-cyanicide.

HOME-MADE CYANIDE PLANT

By W. F. BOERICKE and B. L. EASTMAN

(November 21, 1908)

The following description of a home-made cyanide plant may prove interesting in showing how low-grade tailing, formerly thrown away, is being treated at a profit by a couple of men, at small cost of labor and supplies, and a trifling initial expenditure of capital. This little plant treats the tailing from the 40-stamp mill of one of the large mines of the Grass Valley district, California. The man-

agement of the mine has not felt justified in going to the expense of erecting a large cyanide plant, as the tailing assays only from 40c. to \$1 per ton. As the men who put up the plant had no contract with the mine for the tailing, they naturally sunk the least possible amount of money in the enterprise, in view of the precarious source of their supply of material.

The mill tailing is collected below the mill in sluice-boxes, and carried a half-mile down the ravine in V-shaped overhead launders. It is then allowed to flow directly, without previous sizing, into one of a series of five leaching-vats. These vats are each 18 ft. diam, and 5 ft. 6 in. deep, constructed of 2-in. redwood, and hold 40 tons of sand. One charge is obtained in 24 hours. The distributor for the sand was constructed on the ground, and has some special features, having the merit of so mixing the sand and slime that a charge with as much as 20% slime can be successfully leached. It has six arms 7 ft. long and 20 in. wide; each of these is divided into 12 separate channels, down which the sand flows from a round central sand-box. Each channel comes to a stop before the end of the arm is reached, and a hole is bored through the bottom, through which the sand drops into the vat. These holes are so arranged that the sand is evenly distributed. Hence there is no need of leveling the vat when it is filled. The surface is almost as level as a billiard table, and solution can be run on at once. Before entering the channels, the sand flows into a round box which is pierced at the bottom with 1-in. holes, through which the pulp spurts evenly. The launder that feeds the sand-box has four large holes, insuring even distribution without packing. Unlike most distributors, this one is lowered into the vat to be filled, and raised gradually by a windlass, a barrel of rocks serving as a counter-balance. A large proportion of the slime is floated off immediately through a system of plug-holes, of which there are three rows, 6 in. apart, the holes being 2 in. diam. As fast as the vat fills, a plug is put in and the one above is knocked out; thus there is no loss of sand, but the slime has no chance to settle, as might be the case if the holes were only at the top of the vat.

Instead of using the familiar lawn-sprinkling device, the distributor is turned mechanically by a system of cogwheels and bicycle chains at about one revolution ever 7 min., which is slower than most distributors. The initial power is furnished by a small stream of water falling on a home-made overshot water-wheel. The distributor travels back and forth over the leaching-vats on overhead tracks, and is pulled along by a windlass and wire ropes fastened at either end. The vats are emptied by 'hosing out' the sand through a sluice-gate at the bottom, 6 by 6 in. square. This takes about three hours.

The sand is leached in the regular manner, and receives a 96-hr. treatment. Two strengths of solution are used, the first of about 0.2%; the second is weaker; about 10 tons is introduced at one pumping, about 100 to 125 tons of solution being used altogether. No lime is added. Between each batch of solution the charge is

drained for 1 to 5 hr., depending on how the sand leaches. The cyanide consumption amounts to about 0.6 lb. per ton, and the extraction is generally above 85 per cent.

The zinc-boxes are half-barrels, caulked and painted. The barren solution flows into a sump, from which it is pumped direct, after the necessary cyanide has been added, to the leaching-vats, and a small Dixon pump, which, being valveless, requires little attention. A 12-ft. wooden overshot water-wheel, constructed on the ground, gives ample power. The precipitated gold is dried on an open hearth-furnace, the zinc being partly volatilized. It is then sent to a local assayer for refining, and sold to the mint.

PROGRESS IN CYANIDATION

By ALFRED JAMES

(January 2, 1909)

INTRODUCTORY

In reviewing progress in this important branch of metallurgy, I venture to remind my fellow-workers that only by mutual co-operation can efficiency be maintained. One man can only hope to achieve a certain amount (let us term it x) of work, but 100 keen technical men putting their experiences together ought, by each proceeding from the other man's achievement instead of repeating the preliminary failures and troubles and costs necessary to attaining that position, to be able to accomplish something more nearly approaching 100 x . Let us realize what it means to make the same mistake only once, and proceed one step farther and realize what it would mean if the same mistake were made only once by one man out of the 100; then we can appreciate how even details of difficulties and failures are of value—it may be as examples of what to avoid—as well as triumphant records of difficulties smoothed out, losses eliminated, costs lowered, and extractions raised.

My notes of last year were necessarily hurried and cursory. They were written at sea, far from my records. Since then I have had an opportunity of visiting two of the greatest and most advanced mining regions, Mexico and South Africa. Such personal contact with local problems is of immense service, for the greater and wider an individual's experience the more he finds to learn.

SLIME PROCESSES

Once more progress seems to have centred mainly in the production and treatment of slime. All-sliming may certainly be a moot question for certain ores, when the sands may be treated cheaply by percolation and do not yield a greatly higher extraction by total-sliming, but nevertheless all-sliming certainly seems to have 'come to stay,' as anyone cannot fail to believe who sees already scrapped the huge nearly new Blaisdell equipments at El Oro and Dos Estrellas; scrapped not for any fault of the apparatus, but because all-sliming with cyanide solution through the mortar-boxes has taken away the very reason for the existence of these

labor-saving appliances. Anyone who has studied J. C. Butler's (Guanajuato) curves showing the amount of gold coming into solution in the battery against that dissolved in the sand-vats must find considerable food for thought; indeed, one is tempted to wonder whether the natural result of such a curve is not to indicate the desirability of abandoning the sand-plant entirely, delivering the pulp, properly prepared, into the slime-vats. Even in the chief goldfield of Mexico (El Oro) copper plates are already disappearing, but in spite of their having been ripped out at the El Oro and Dos Estrellas mills, the gold extraction obtained does not appear to have suffered either in cost or percentage, but rather the reverse.

As a result of the general inclination to sliming, increased attention has been given to means of fine crushing. Tube-mills have more than held their ground. We no longer hear of 'pans *v.* tube-mills' tests. Tube-mills are being installed almost everywhere with the exception of Australia and India. New types of mills have been advertised, but the old long cylindrical form still holds the field, with an established preference in big plants for a mill of from 4 ft. to 5 ft. 6 in. diam. by 19 to 22 ft. long. In the matter of certain tube-mill details, and of air-agitation, and of the widespread adoption of vacuum-filtration, Mexico has certainly been setting an example to the older cyanide regions, except New Zealand, which for the last two years seems to have led the way in tube-mill liners, air-agitation, and basket vacuum-filtration.

Other factors in Mexican practice are the large quantities of lime and lead acetate used for treatment purposes. It is a matter for serious question whether the use of lime is not carried to extremes, and whether some of the difficulties met with in the slime-treatment do not arise from an excess of lime. Thus at Guanajuato one of the companies feeds in 22 lb. of lime per ton of dry slime treated. At El Oro 15 lb. is used and at Dos Estrellas the practice is nearly the same. One of the results of this large consumption and solution of lime is the ever-present necessity of immersing the absorbent vacuum-filter-leaves in dilute acid to restore their permeability.

Caldecott shows that lead acetate acts as a carrier, the eventual result being that the sulphur reacts on the cyanide to form sulphocyanide, leaving the PbO free for further action. I seem to remember investigating this matter in the laboratory some twenty years ago and coming to a somewhat opposite conclusion—based on the small amount of KCNS formed—but whereas in Australia very small quantities of lead acetate are used (say 2 lb. to a charge of 50 tons of roasted ore) in Mexico 16 lb. is used per ton of slime at Guanajuato, compared with $\frac{1}{2}$ lb. per ton at El Oro, where crushing to 25 to 30 mesh takes place, with heated 0.03% KCy solution passing through the battery. Contrary to the Caldecott equation, Mexican chemist state that the amount of lead salt required equals the corresponding amount of sulphur present in solution from the silver sulphide dissolved.

In central and south Mexico they are blessed with cheap power;

effective horse-power costs from £10 per annum at one district, to 10d. per day in another—less than $\frac{1}{2}$ d. per hour. A feature of practice at El Oro is the provision of well-designed, roomy, neat extractor-houses which are better than those I have seen in any other part of the world. The extractor-boxes are raised some little distance above the main floor, which is cemented with drains running to a pump-sump. All precipitate is sieved through a 60-mesh screen, and thus 'shorts' are kept out of the bullion, and acid treatment is avoided. The shorts, or roughs, are placed on trays in a special extractor-box and become fine at the next clean-up. Press precipitate is briquetted before fusion and makes a remarkably clean and neat product. Oil furnaces are in use, but tilting furnaces do not yet appear to have been adopted.

At Guanajuato large values have been carried away in the slime-residue. During my visit residues containing 45 grams silver per ton, most of it in solution, were being run to waste down the creek. This does not mean that the men in charge were not keenly alive to what was being lost. The development of vacuum-filtration is recent, and though its spread has been remarkably rapid in Mexico, it is not yet universally adopted. These residues when put through a Ridgway filter were impoverished to 13 grams silver, no dissolved silver remaining.

In Africa attention has been mainly devoted to lessening working costs, and the extraordinary spectacle is now presented of mines running at practically half of their former outlay, and of mines that are the richest as well as the largest in that territory, and in the world, running at working costs, including mining, handling, and treatment, of only 12s. per ton. In mechanical details there is still that keen rivalry between the two leading groups which has done so much for the advancement of the Rand. The 'Gold Fields' lead in their now universally adopted development of huge mills and heavy stamps. Already the output is stated to have grown to 9 tons per day per stamp (Luipaards Vlei, 'Gold Fields' group, 1650-lb. stamps) and the limit is not yet reached. The Simmer Deep mill of the same group has 1670-lb. stamps, capable of being weighted to 1800 lb., and it looks as though it would not be long before a falling weight of 2000 lb. will be reached. On the other hand the mechanical genius of the Rand Mines group has been evolving some interesting results on peripheral discharge with tube-mills, and has been displacing the wellnigh universally adopted tailing-wheel by centrifugal pumps of special design and local manufacture. Metallurgically the Gold Fields people have also done exceedingly well. Caldecott's forecast of tube-mill results, as I have previously pointed out, were confirmed most remarkably in practice, and now he seems to be hard at work evolving a filtering process for the treatment of slime.

In Australia interest has centred on flotation processes for concentration, rather than on improvement in gold-ore treatment. Kalgoolie seems to have reached its zenith, and to have settled down to steady practice. The treatment-costs given in detail in my re-

view of 1906 still apparently hold good. The Ivanhoe costs for August, 1908, are 7s. 6d., as against 9s. in 1906, and those of the Great Boulder for the same periods are 11s. 6d., as against 11s., but, on the other hand, the other companies then mentioned—the South Kalgurli, the Great Fingall, and the Sons of Gwalia—show higher costs on the same basis. This reference to the Ivanhoe brings to mind the old controversies over roasting as against bromo-cyaniding (now dead), and pans as against tube-mills, in which this mine formerly figured prominently. It now appears, from local records, to have been at that time making particularly poor extractions—which tends to discount the low costs published—and a local metallurgist from Oroya-Brownhill, E. S. King, has recently sustained his claim at law for a large sum as recompense or fee for helping them out of their difficulties.

American practice seems linked with that of Mexico (largely controlled by Americans), and so the last year has been chiefly a chronicle of air-agitation and vacuum-filtration, as in Mexico, with much newspaper fulmination and advertising of rival filtration processes, and with the local success of the Merrill pressure-filter in South Dakota to offset the work of the Burt at El Oro.

AGITATION

One of the features of the year has been the success of the Brown system of agitation, originally brought out at Komata, New Zealand, and adopted by the Waihi company. The latest and largest plants in Mexico and the United States have adopted this system, which has now penetrated into Africa and South America. Daue has recently written a remarkable comparison in the *Mexican Mining Journal* for October, and shows at the San Francisco mill at Pachuca a consumption of only one-twentieth of the horse-power used at the mechanically agitated Loreto mill, the Brown agitator showing considerably better extraction with a cheaper plant and giving a much shorter cycle of operation. The whole article is worthy of careful perusal. It seems abundantly proved that a charge of 80 tons (dry) of slime can be kept in a condition of efficient agitation with a consumption of $1\frac{1}{2}$ horse-power.

Much time has been spent in Mexico in endeavoring to improve the mechanical agitator by the use of footstep bearings with mercury seals and other devices, but the mercury seals in practice have proved unreliable and have manifested a considerable tendency to the formation of base amalgam, as one would anticipate from the behavior of this metal in amalgamating pans. Owing to the well known refractoriness of silver sulphide ores, the agitation periods are much longer in Mexico than elsewhere; indeed, 48 hours of mechanical agitation is not uncommon—a practical impossibility in any country where power is not extraordinarily cheap. Daue, in the article mentioned, shows that at Loreto the ore requires 84 hr. of agitation, whereas, with the same class of ore at the San Francisco, the period of agitation is reduced by the use of air-agitation to 24 hr., with a lessened cyanide consumption.

VACUUM-FILTRATION

Undoubtedly the feature of the year has been the success of vacuum-filtration. With such a combined host of talent as Nichols, Thompson, Moore, Barry, Ridgway, Brown, Nutter, Cassel, Butters, Hunt, Parrish, Argall, Ogle, Leslie, and Caldecott, and I know not how many others, vacuum-filtration could scarcely have failed to accomplish great things, and already five continents are eagerly investigating it with a view to adopting the practice in one form or another.

Even if we assume only 1,000,000 tons of slime handled by this process during the last year, it would still be a remarkable figure for a new method, but, on the data given, the Ridgway and Barry machines alone must have handled over half this amount, and therefore the total tonnage treated by the various methods, notably the Butters, must considerably exceed this. But in addition to the two

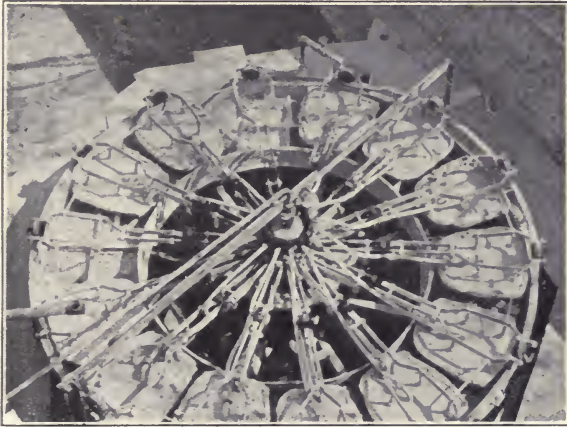

Fig. 48. THE RIDGWAY FILTER IN PLAN

methods first mentioned, the Butters filter can fairly claim to be a great factor in present-day practice. That it has achieved this position is surely a tribute to the energy, push, skill, and remarkable engineering ingenuity of the man at the helm and of his associates. So attractive and so simple does the filter look that nothing seems easier than to run in the slime at one end, turn a handle, and have the pulp running away at the other end, with the gold solution pouring into the precipitation-boxes. Ridgway, in Australia, not content with the success of his flat-plate machine, has been trying to make a larger unit by substituting a basket for a flat plate, thereby largely increasing his filtering area. I am not sure, however, of the soundness in practice of his later idea, of which one hears most laudatory accounts from disinterested sources in Australia. The principles governing the discharge of a flat plate and of a vertical plate are

not entirely the same, and it looks as if the combination type must sacrifice something of the rapidity of the Ridgway and of the elasticity of the basket type for the sake of the greater capacity per unit.

For automaticity can only be gained at the expense of elasticity, and hence it happens that the prettily running, apparently ideally simple Ridgway, with its perfect wash and its huge output per unit of filtering surface, needs for its effective working a strict adherence to the principle on which its design is based. The duty of a filtering machine is based on the amount of water or other fluid drawn through. The cake formation of residue is a sequel or a by-product, although for us it may be the all-important matter of tonnage treated per diem. Now, in a rapid-working machine like the Ridgway, it is evident that the amount of solution drawn through is mainly a function of time of immersion and not of amount of 'clog' or lessening permeability of cake.

Assuming, then, that a standard Ridgway has a solution-drawing capacity of 50 tons plus wash, then when treating the 50% pulp for which the Ridgway was designed, it follows that 50 tons of solution drawn through leave as a deposit on the plates 50 tons of residue. If, however, a pulp of 66 or 75% moisture is being handled, then 50 tons of solution drawn through leave behind only 25 or 17 tons, respectively, of slime-tailing at a daily output.

It has become evident that for the successful working of automatic machines it is necessary to adhere rigidly to the condition of pulp thickness. With semi-automatic filters such as the Barry, Butters, Cassel, and Moore types this is not of so much moment. Here flow is a function of 'clog,' as the cakes must be thick enough (four to eight times thicker than the Ridgway) to strip off a vertical frame. Possibly the last $\frac{1}{8}$ in. of cake deposited takes 64 times as long to form as the first portion or section of similar thickness, and thus if the solution is dilute one merely allows the cake a longer period of formation—it may vary from five minutes to one hour or even more—and adds a few more frames to make up for the greater time taken. The moral of this appears to be that if one wishes to use an automatic machine one must either have a 50% pulp or provide a suitable thickener, such as the Dorr, or settling-vats for this purpose. In Western Australia they find no difficulty in handling a pulp containing 55% solids; this is obtained by a constant flow from the first line of pointed boxes and an intermittent flow scraped down by a shovel from the second and third lines. In Africa in their settling-vats a pulp of similar thickness is encountered, but does not run with the same readiness. The more flocculent a pulp the greater percentage of moisture necessary to make it mobile. At Guanajuato we obtained a slime pulp by settlement so thick that it would stand up in ridges—like custard—after being stirred, and would not flow freely, and yet it contained 66% moisture.

Again, there is weathered slime so full of acid salts that gelatinous precipitate is formed on the addition of the alkali necessary to economical cyanide treatment. Success may scarcely be expected with

this pulp from any of the automatic or semi-automatic methods employing filter-cloth, unless such salts are first removed by washing. Sand-filters such as the Hunt might be more successful, owing to the constant removal of the upper sand surface and the consequent automatic maintenance of an unlogged filtration surface.

Of the other methods, Moore's would probably have been more widely adopted but for the claim of patent rights over all submerged filters. When were filters not submerged? But more active business methods have during the middle portion of the year led to the securing of some contracts at Pachuca, Guanajuato, and Chihuahua. The process is necessarily more expensive to install than the Butters, but it has equal elasticity of treatment and the advantage of depositing on the dump nothing but washed tailing.

Barry avoids many difficulties by his special frame made of pressed corrugated sheet metal. There is no absorbent material inside the cloths, nor has he distance-pieces of wood on the face of his frames to offer resistance to the stripping of the cakes. His method is similar to the Moore, but differs in not necessitating a reversal of flow for discharge, and in permitting efficient agitation of pulp in the filter-vat. Then there are the pressure-filters of the Merrill and Burt types. I understand the former is still reeling off records merrily under its special conditions in South Dakota, but it is said to have been a failure in Mexico during the early part of this year—possibly the fault of local conditions. Burt is taking advantage at El Oro, as Merrill did in Dakota, of a gravity feed for his suspended-frame type of pressure-filter. It is difficult to understand how such a filter can wash its product prior to discharge. It was admitted to be discharging an unwashed output at both the mines at which it was installed in Mexico at the time of my visit.

ROASTING

No improvements in roasting furnaces seem to have been made. The new Edwards furnaces have apparently given considerable trouble at the Lancefield, and they have been modifying the position of the auxiliary fire-boxes. The increased length seems to have tended toward the production of an unhandy unit.

CRUSHING

In Mexico the demand for an installation without stamps is continually heard. At one well known mine the Huntington mills installed were unjustly damned. Elsewhere poor success with Ferraris ball-mills is reported, and so the cry is for a simple installation using wet-crushing rolls. At Pachuca Francisco Narvaez is running Chilean mills, 8 ft. diam. by 16-in. face, with some success. These machines are of the slow-running type, making 10 rev. per min.; each wheel was stated to weigh 10 tons. For a consumption of 10 hp. each mill crushed 15 metric tons per diem from 1½-in. cube to a pulp 80% of which will pass through 200-mesh, at a cost, including 10% depreciation, of 70 centavos, or 17¼ pence per ton; but I noted that this was on soft ore ('fines'); the hard rock was fed to ball-mills, and then to a tube-mill and crushed dry.

Reference has already been made to the installation of heavy stamps on the Rand. R. G. Fricker of the Gold Fields group, presiding at the recent Simmer & Jack meeting, showed that, largely as the result of using tube-mills, they have increased their profit on 7.6 dwt. ore from 12s. 9d. to 16s. 1d., or the addition of 3s. 4d. per ton, which shows a remarkable gain, attained entirely by increased extraction and lessened costs. He added that the introduction of tube-mills had had a marked effect on the mining conditions of the Rand, second only, perhaps, to the application of the cyanide treatment many years ago.

The following are some of the early tube-mill results: Redjang Lebong, without tube-mills, screen 35 mesh, output 2.85 tons per stamp per diem, extraction (sand) 79%; with tube-mills and 16-mesh screening, output was raised to 3.6 tons per stamp per diem, or 27% increase, for an 85.3% extraction. This ore is very hard.

Robinson Deep, with two tube-mills per 200 stamps, increased the output by 10%, and the profit by 1s. per ton milled. These examples of early results are given because they were obtained prior to the period of the use of lode matter in place of pebbles for crushing and for liners. This later practice, modifying as it does both the power and the output, tends to complicate comparisons. Generally the tendency is to reduce the larger outputs per tube-mill obtained in 1906, and to use more power, so that already on the Rand the point has been passed where it is cheaper to increase output by tube-mills instead of by stamps. Ninety horse-power is now used for a 5 ft. 6 in. by 22 ft. tube-mill for an output of 140 tons per day, crushing through 60 mesh. But the increased extractions and the much lower residues, which have been reduced from 0.4 to 0.15 dwt., are tangible evidences of the claim for the present practice that the higher extractions obtained by the greater power employed are also the cause of higher actual profits. They do not appear on the Rand to have improved on the costs of 5.71d. per ton of ore tube-milled, given in this review two years ago.

At El Oro, at first sight the impression is that the tube-mill is not being pushed to its full capacity, and that the horse-power consumed is high in proportion to the output of 1.1 to 1.2 tons per hp.-day. These figures do not shine in comparison with those of the Waihi, which also has a very hard ore, given in these notes for 1906, namely, an 18-ft. mill grinding 77 tons of 20-mesh sand per diem so that 93% passes 150-mesh, with a consumption of 37½ hp., but on closer comparison it appears that the classifying at El Oro was more thoroughly done than at Waihi, so that less actual slime is fed in the sand to the mills; that the standard of crushing at El Oro is somewhat finer; and that El Oro has done away with the use of pebbles and crushes with ore-lining entirely. Moreover, the El Oro policy of having a strong reserve of tube-mill capacity makes not only for comfort in management but in the ability to cope with the unexpected, and elasticity in treatment-method is probably responsible for the many accepted improvements in tube-mill practice which have come to us from El Oro. These are referred to later.

They certainly have taken nothing for granted there, but have worked out their practice for themselves. At no other mill probably can be seen such a variety of tube-mills as at El Oro. In addition to two tube-mills of a make not preferred, they have five tube-mills of a well known make, three No. 3, one No. 4, and one No. 5, the size preferred being the No. 3, 4-ft. diam. by 19 ft. long. The Waihi tube-mills are 5 ft. diam. by 18 ft. long, and, like those at the Knights Deep (Consolidated Gold Fields), are smaller than the usual Rand Mines standard of 5 ft. 6 in. diam, by 22 ft. long.

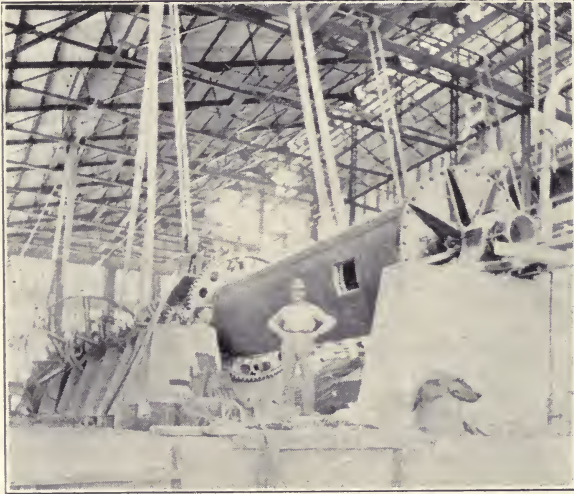

Fig. 49. TUBE-MILL IN THE NEW PLANT OF THE GOLDFIELD CONSOLIDATED

At El Oro for some time they used a special self-filling cast-iron liner, previously mentioned in these notes, into which the flint pebbles jammed. This liner, however, is not so suitable for the use of vein-matter, which has not the same jamming capacity as flint pebbles, and I therefore anticipate a modification of El Oro practice in this respect, as rough 'cubes' or otherwise irregularly shaped pieces of rock are not so amenable as pebbles for this purpose. About 53 lb. of rock in the form of 3-in. cubes is fed into the mill per ton of sand ground, and this abrades 0.2 lb. of cast-iron liner, the chips and fragments of which are separated from the slimed sand by a 20-ft. blanket-strake. Silix linings were found to have a life of $2\frac{1}{2}$ months.

An ingenious device has been used at El Oro and Dos Estrellas, called the Neal discharge, which practically maintains an open end, through which the cubes, and at Dos Estrellas the rocks, are fed by belt, by chute, or by hand, as desired. The device is remarkably simple, and consists of an internal annular ring, or baffle, around the orifice, with or without a reverse-worm. This retains all pebbles.

while permitting the egress of slimed pulp. I have referred before to the Barry lining, the cost of which at Waihi (fine sliming of hard ore) is 0.72 pence, or 1.4 cents, per ton of sand slimed. In Africa they appear to be still using local or imported silex at an apparent cost for coarse sliming of only three times this amount. In a recent paper Mr. Graham refers to "the set of 6 by 6 by 4-in. silex blocks put into our Davidsen mill with diamond cement, that has now run 165 days," which shows a vast improvement over former wear. They use a feed of 4-in. cubes, and Mr. Graham maintains that 8-in. lumps would reduce the effective life of the smaller lumps.

Not much has been heard of peripheral discharge, of late, but in Africa I was shown some remarkable results of tests made by the Crown Reef, using a Danish (peripheral discharge), German (ordinary trunnion discharge), and a local-type mill. At the first trial the local mill gave the lowest results, and was not further compared, but three tests were made of the peripheral mill against the ordinary trunnion-discharge, with the following results:

Trial No. 1.	Peripheral.	Trunnion.
Size of nozzle, inches	1 $\frac{1}{4}$	1 $\frac{1}{4}$
Rev. per min.	26	28
Peripheral speed, ft. per min.	408	425
Feed, tons per diem	251	260
Percentage of water	44	47
Discharge, decrease of +60	43	31.5
Discharge, increase of -90	42.2	25.4
Trial No. 2. (The nozzles of the two mills were changed.)		
Size of nozzle, inches	1 $\frac{1}{4}$	1 $\frac{1}{4}$
Rev. per min.	26	28
Peripheral speed, ft. per min.	408	425
Feed, tons per diem	260	251
Percentage of water	47	44
Discharge, decrease of +60	67.7	45.9
Discharge, increase of -90	49.3	41.8
Trial No. 3.		
Size of nozzle, inches	1 $\frac{1}{16}$	1
Rev. per min.	26	28
Peripheral speed, ft. per min.	408	425
Feed, tons per diem	278	259
Percentage of water	35	35
Discharge, decrease of +60	59.9	48.5
Discharge, increase of -90	51.4	44.5

Thus is shown both a greater tonnage and finer grinding for the peripheral discharge.

I understand that a further test of a year's duration has been made at the Ferreira, and that, as a result, it has been placed beyond doubt that peripheral discharge gives better results than the ordinary straight-through trunnion-discharge. It will be noted that in the above tests no mention is made of flint charge or power taken. Peripheral discharge involves a loss of 4 to 5 ft. in height, and thus will necessitate re-elevating for all mills laid down on straight-through lines which may be converted to peripheral discharge.

CONCENTRATION

The flotation methods appear at present to be causing a great amount of litigation. First we had *Potter v. Delprat*, and now we have *Elmore v. The Minerals Separation Co.* The latter companies both claim success at Broken Hill on lead-zinc ores, but at Avino in Mexico, and at Cobar in Australia the Elmore process has not, under the local conditions prevalent, proved successful in practice. Of the mechanical concentrators, the Wilfley table still appears to hold the field, though I noticed a growing preference in Mexico for the Johnston vanner. Nothing appears to have yet been introduced capable of supplanting the plain table, whether of boards, canvas, or cement, for concentrating gold-bearing slime.

SLIME TREATMENT

As under the heading of vacuum-filtration this subject has already been extensively discussed, I may here summarize the present position by stating that in Africa decantation is still almost the universal method, but it is becoming evident that the days of this process, hugely expensive to install and incomplete in results, are drawing to a close. The recent admission that 7d. to 8d., or more, of dissolved gold per ton was being run away with the slime tailing, has promoted investigation into other methods of treatment. Dehne filter-presses, the Ridgway filter, and one or two other schemes have been put into practice or set to work on a practical scale, and in addition another method, known as the Adair-Usher, has been largely before the public eye. In America vacuum-filtration bids fair to completely throw out decantation and all other methods, though two advocates of pressure-filters are making a fight for it. In Australia filter-pressing still holds the field, but the Ridgway has some installations of considerable magnitude in operation, and the Cassel method has also been introduced at the Lake View. In India it has become obvious that the old method of taking advantage of the climate to deal with the sand and slime mixed must give place to some direct means of treatment, and the Ridgway has been installed on two fields for experimental investigation.

In eastern Asia a large Ridgway installation has been laid down where previously filter-pressing held the field, and another similar plant has also been acquired by another group, previously wedded to filter-pressing. It looks, therefore, as though decantation on the old lines, and even filter-pressing, is doomed to disappear, though in a less expensive guise decantation may still remain to form a portion of a more thorough process.

ADAIR-USHER

*I looked into this process during my recent visit to Africa, in view of the great amount of publicity given to it by the technical press, and the great success and general adoption advertised. I have already referred to the lack of success attending up-

*For discussion, see *Mining and Scientific Press*, July 17, September 4, September 25, 1909.

ward percolation of solution and wash-water, as investigated by Holms in Mexico, Ward at Kalgoorlie, and Hunt in Costa Rica—did not Godbe patent this several years ago in the United States of America? At the first mine to which I was taken on the Rand I saw dirty solutions coming off from the vats—surely evidence of poor work. At another mine, however, the Ferreira, I found a much better condition of affairs. There the metallurgist had apparently realized the impossibility of obtaining good extractions or of running off clean solutions by continuous upward percolation, and consequently he treated the process as merely an adjunct to the decantation process, to save a final transfer. He pumped his slime into collectors in the ordinary way, settled, decanted the water, and then transferred with dilute cyanide solution to the agitator-vats. After agitation for five hours the pulp was transferred to the Usher vat (an ordinary vat provided with a radial system of perforated pipes along the bottom), weak solution being fed through the perforated pipes during the charging, and indeed until the charge is 6 in. from the top of the vat or the decanter. The charge was then settled until the upper portion was quite clear, and then the solution was turned on through the radial perforated pipes at the rate of 10 to 12 tons per hour; this is for a 150-ton charge. This flow of solution was maintained for 36 hr. out of a total treatment time of 72 hr. The solution was then cut off and the charge allowed to settle, the solution being decanted to the agitator-vats. The Adair-Usher process thus becomes merely a method, not a solution, but of avoiding, with the aid of decantation, a final transfer. It has the advantage of saving the cost of one transfer ($2\frac{1}{2}$ d., or 5 cents), and of leaving the washing-vat free for other use. But as a matter of practical economics it is possible only in such a process as South African decantation with its huge plant, heavy pumping charges, and necessity for treble handling. It largely increases the bulk of solution to be handled—5 or 6 of solution to 1 of dry slime—and sends to the dam an amount of solution carrying not less than 4 to 6 grains of dissolved gold per ton, at least equal to the weight of the tailing discharged. From careful inquiries I could find no gain in extraction or decreased value of tailing resulting from the use of the Adair-Usher wash, but a saving of time and of vats from the avoiding of the final transfer and wash. In a word, as a solution-process the Adair-Usher seems to be no more feasible than the upward percolation tried elsewhere, and to have the same liability to mingle rather than to displace, and the same necessity for the employment of much solution, all taking up KCy and gold. Actual displacement indeed has not yet been recognized. On the contrary, alteration in 'head' or the slightest increase in heat of the solution pumped into the Adair radial pipes, causes an ascending stream through the pulp.

CLEAN-UP

I have referred elsewhere to the characteristic neatness of the Mexican clean-up plants based on absolutely the old safe lines of fine sieving and avoiding acid treatment and roasting. I am rather sur-

prised that no one has tried T. K. Rose's method of purifying base bullion, and even precipitate, by introducing oxygen or air into the melt through a pipe-stem. Full details of this method were given in a paper presented to the Institution of Mining & Metallurgy, and from a demonstration in my presence it seemed that this process was most simple, even on base metal.

PROGRESS IN CYANIDATION.

(February 20, 1909)

The Editor:

Sir—It is an accepted principle in our profession that a mining engineer is entitled to have his report published in full or, alternatively, that any extracts from his report be submitted for his personal approval prior to publication. In your case you do me the honor to publish my review of progress in cyanidation at greater length than the manuscript sent you for publication authorizes. Doubtless your reason for this is your knowledge of my views on certain vacuum and pressure filters and the impossibility of communicating with me prior to your going to press. I must therefore take this opportunity of stating that the eulogistic views attributed to me in your issue of January 2, relating to some of the vacuum and pressure filters do not represent my whole views, and, on the other hand, had I decided to publish any statement regarding the Burt filter I should have wished to offset my remarks as to the possible difficulty of effective washing by this filter, by a reference to the remarkably low costs of its operation, shown by the figures published of the work at El Oro.

ALFRED JAMES.

London, January 25.

(January 30, 1909)

The Editor:

Sir—I had the pleasure of reading in your issue of January 2 the article by Alfred James upon the 'Progress of Cyanidation' during the last year, and I find myself obliged to make a correction. It is true that until the month of June last we had a ball-mill at work with its grinding pan for dry-grinding, but the class of ore which this mill ground was precisely like that ground in the Chilean mills. It is an ordinary quartz ore, the only notable difference in the two cases being in the size of the feed; for while we fed ore from 3 to 4 in. diam. into the ball-mill, the size going to the Chileans was 1½ in. as a maximum, that being most appropriate for mills of that type. Neither did we feed soft ore to the Chilean mills.

FRANCISCO NARVAEZ.

Pachuca, Mexico, January 11.

(March 13, 1909)

The Editor:

Sir—In your issue of January 30, I notice the appreciative reference of Capt. Francisco Narváez, of Pachuca, to my article upon 'Progress in Cyanidation', and note that Capt. Narváez now does all his crushing by Chilean mills. This is interesting news, and I hope he will give us the benefit of his most recent results, including wear and tear, working costs, horse-power, consumption, fineness of original feed and of crushed product. It will probably interest him to know that his work is being keenly followed elsewhere, and that in Rhodesia particularly Chilean mills are being largely employed. My reference to soft ore is evidently due to a misunderstanding of his precise expression when he was so good as to personally give me details of his work. The feed to the Chilean mills was obviously finer than that sent to the ball-mills, as Capt. Narváez now confirms, and I understood him to say it was also softer. The correction apparently makes my statement as to the work of his mills all the stronger, for it now appears that he is able to crush 15 metric tons per diem for a consumption of 10 hp. from 1½ in. cube to 80% through 200 mesh at a cost, including 10% depreciation, of 0.7 peso (17¼d.) per ton on the general average rock produced by his mine. Possibly these results have already been improved on by him.

ALFRED JAMES.

London, February 17.

LEAD ACETATE IN CYANIDATION

(January 9, 1909)

The Editor:

Sir—I should like to call the attention of other cyanide workers, especially of those using lead acetate in their work, to a case where, in a mill in charge of the writer several years ago, litharge was substituted for that salt, to good advantage. The material being treated was a concentrated tailing re-ground to pass 50 mesh, the greater part of the slime being removed before treatment by agitation in vats 20 by 20 ft. Thus the material agitated was largely fine sand, containing much pyrrhotite and a little arsenopyrite and chalcopyrite. The stirring action was very strong.

Soluble sulphides formed during treatment required the addition of at least 2½ lb. lead acetate per ton of solids in the charge. As this formed a heavy item of expense, William Magenau, the chemist of the mill, experimented with other lead salts and found that litharge, added to the charge in the proportion of 1½ lb. per ton, was equally effective. As litharge cost only half as much as acetate, it effected a reduction in cost for this item to 30% of the former figure. Besides, it was easier to use, simply requiring to be weighed and sifted into the agitating charge.

This substitution may not be generally applicable, nor in some cases even possible, but it has occurred to me that it might be used

to advantage in tube-mill work, adding the litharge with the feed. This would be the logical place to add the litharge when grinding in tube-mills with cyanide solution, which, in my opinion, is likely to be the practice of the near future.

C. M. EYE.

Taracol, Korea, November 26.

LOSS OF CYANIDE

(January 16, 1909)

The Editor:

Sir—In your issue of November 7, Rivers R. Baildon asks for “some information regarding the mechanical loss of cyanide incurred in operating such slime-filters as the Moore, Butters, Kelly, or Burt.” The loss due to chemical decomposition is difficult to determine; but cyanide consumption is due to chemical loss and to mechanical loss. Each ore treated by cyanidation causes an unavoidable chemical loss of cyanide, which is constant for any given set of conditions. The factors determining the chemical loss vary with the character of the ore, the loss increases with fine grinding, increases with strength of solution used, depends upon the degree of alkalinity of solutions, and upon the amount of solutions used per ton of ore.

Mechanical losses are due to leakages, and to loss of cyanide in the discharged residue. The following is an account of losses in the North Star mill, at Kofa, Arizona. The ore is a hard, compact, silicious rock, carrying much free gold. Losses from leakage are slight. Losses in residues from the Kelly filter-press vary from 0.04 to 0.7 lb. per ton of residue discharged, the amount being directly proportional to the cyanide strength of the wash solution, and to a lesser degree to the length of time of wash, and rate of wash. The ore, after coming from dry-crushing rolls and passing through a No. 16 mesh screen, is fed to an Abbé silex-lined tube-mill, and ground to slime, in a cyanide solution containing about 4 lb. potassium cyanide and from 2 to 4 lb. lime per ton. The ground slime receives an air-agitation in cone-bottomed vats, after which it goes to the Kelly press.

An actual example of the working of the press and of the mechanical losses follows, the filter-press charge consisting of 1066 lb.:

	Minutes.
Time filling press with pulp, sp. gr. 1.27	4
Time loading frames	12
Discharging pulp and re-filling with solution	5
Solution wash	10
Discharging solution-wash and re-filling with water-wash	4
Water-wash	10
Discharging water-wash	2
Discharging cakes and returning frames	21

Total time of cycle..... 1 hr. 8 min.

The cake formed contained 28.4% moisture, was 1¼ in. thick,

and there were 410 sq. ft. of filtering area. The cyanide in the original pulp was 4.7 lb. per ton of solution, and the cyanide in the wash-solution was 3.8 lb. per ton.

The water-wash began at 0.4 lb. KCy per ton and ended at 0.2 lb. per ton, due to the addition of fresh water during washing. The actual mechanical loss in this case was 0.0568 lb. KCy per ton of dry slime. No cyanide solution is intentionally run to waste in this plant. For this reason, the wash-water is sometimes dispensed with to prevent an accumulation of mill-solutions. Had a 20-min. solution-wash been given, instead of the solution-wash followed by the water-wash, the mechanical loss of cyanide would have been 1.07 lb. per ton of dry slime. The actual total cyanide consumption over a period of three months, calculated from tonnage of ore treated and the potassium cyanide used, was 2.23 lb. per ton of dry slime.

The cyanide loss, per ton of dry slime, at the Butters Devisadero mines, in Salvador, Central America, in the summer of 1906, was 3.38 lb. KCy per ton of dry slime. This plant was then all-sliding. The ore was slided in cyanide solution in a tube-mill having a cast-iron lining; the fine iron worn from the lining was accountable for the high cyanide consumption. A test made when the pulp carried 0.12% KCy per ton of solution, with wash-solution at 0.058% and wash-water free from cyanide gave at the end of a 45-min. solution-wash 0.069% KCy in the discharged solution, and at the end of a 30-min. water-wash 0.039% KCy in the discharged solution. The moisture in a cake from the Butters filter runs from 28 to 40%. The mechanical loss of cyanide is from 0.21 to 0.55 lb. KCy per ton of dry pulp.* Cyanide solution was never intentionally run to waste.

DANA G. PUTNAM.

Kofa, Arizona, December 18.

TREATMENT OF THE GOLD AND SILVER PRECIPITATE AT DOS ESTRELLAS

By WALTER NEAL

(February 27, 1909)

At the clean-up in the Dos Estrellas mill, El Oro, Mexico, the gold and silver slime flows by gravity through launders from the zinc-boxes, first onto a 20-mesh screen, next to a 60-mesh screen, and thence to the first of two cement sumps. The short-zinc resting on the 20-mesh screen is returned to the head compartment of the zinc-boxes after being thoroughly washed; that passing 20 mesh and resting on 60 mesh is dried and melted, without acid treatment. From the first sump above mentioned the slime overflows to a second, whence it is pumped to the filter presses by a triplex plunger-pump. The idea of using two sumps is to hold back the greater part of the slime in the first, thereby enabling the pump to be run

*'The Filtration of Slime by the Butters Method.' E. M. Hamilton, *Mining and Scientific Press*, June 29, 1907.

at full speed till work on the boxes is finished, and the zinc-room man can give more attention to the press. Then while the sumps are being pumped out, short-zinc is washed and the launders cleaned. Lastly the heavy sludge in the first sump is pumped out, and the sumps thoroughly washed.

After the clean-up is completed the precipitate is partly dried by passing compressed air through the cakes in the press. The press is then discharged into a movable steam-jacketed drying-car which is run under the press to receive the cakes, then returned to its place, and connected to the steam line, the cakes being left to dry all night. A small vertical boiler is used for generating steam for this purpose, and is fired for about two hours, the fire being then 'banked' and the steam allowed to drop slowly. The cakes are melted the succeeding day; they contain only about 18% moisture. Until recently the precipitate was briquetted after fluxing, but this has been discontinued on account of the amount of handling involved. At the present time the precipitate is handled only twice, as against six times in briquetting, as follows:

Briquetting.—1. Cakes knocked from filter-frames to drying-car; and the car wheeled to place and steam connected.

2. Cakes shoveled from drying-car to fluxing-boxes; weighed; and fluxes added.

3. Mixed with shovel in boxes; and boxes wheeled to briquetting machine.

4. Precipitate shoveled from boxes to hopper of briquetting machine.

5. Briquettes lifted from briquetting machine by hand and placed in boxes; and run to furnace.

6. Briquettes placed in shovel and fed into crucibles.

Without Briquetting.—1. Cakes knocked from filter-frames to drying-car, care being taken not to break up cakes more than necessary; car wheeled to place, steam connected, dried, weighed entire, fluxes spread evenly over top of precipitate (without mixing), car run to furnace.

2. Precipitate and fluxes shoveled to crucibles.

Briquetting is a good thing, and it is also well to mix the fluxes intimately with the precipitate, but no one who has ever got some precipitate on his finger and tried to wipe it off on his overalls will dispute the statement that handling is a bad thing and spells 'loss'. Further, the precipitate at Dos Estrellas seems to melt as readily and to give as clean a slag without as with mixing. Care being taken not to break up the cakes as they fall from the press is almost as good as briquetting to prevent the precipitate from caking superficially and 'blowing' during fusion. The loss by dusting of such wet material is negligible. The flux generally used is:

Precipitate	100
Borax	15
Soda bicarbonate	8
Sand	4
Scrap wrought-iron in excess.	

The precipitate yields from 60 to 80% bullion. Coke is used as fuel at the two plants of the Dos Estrellas Co., but fuel oil by the El Oro and Mexico companies. Number 400 Dixon or 371 A Morgan crucibles are used, each crucible holding about 86 kg. of mixed precipitate and fluxes. After fusion the upper portion of the molten mass in the crucible is poured into a conical mold with a clay-stopped tap-hole about three inches above the apex. The lower portion is poured into ingot molds. As soon as a shell of slag about $\frac{1}{2}$ in. thick has formed in the 'tapping-mold' the clay plug is removed and the fluid central core is allowed to flow into another mold. A sample of the issuing slag is taken and granulated by being poured into water. The 'shells' from the conical molds, and the slag from the ingot-molds are re-melted, poured into conical molds, and tapped as before. The cores are sacked and shipped at intervals to the smelter.

The slabs of bullion from the ingot-molds, together with the buttons from the tapping-molds, are re-melted, no attempt being made at refining. On pouring the final bars two samples are taken: the first from the crucible after skimming the molten metal, and the second while pouring the bars. It is of interest to note that in 12 months, during which time a total of 35.23 metric tons of bullion was melted, the total difference in value of the bullion as indicated by the two samples was only ₧1963.69. The sample taken while pouring gave the higher results.

The short-zinc passing 20 mesh and resting on 60 carries from 5 to 10% of metal and is melted with the following flux:

Short-zinc	100
Borax	40
Soda	20
Sand	10
Lime	5

This flux gives a very fluid slag carrying about 40% zinc and exceedingly poor in gold and silver. The resultant metal carries about 20% zinc. Being so small a quantity in proportion to the total amount of bullion, the 'zinc metal' is added to the slabs of metal which come from the screened precipitate at the second melting.

CHEMISTRY OF THE BROMO-CYANOGEN PROCESS

By S. H. WORRELL

(March 6, 1909)

In 1894 Sulman and Teed, two English metallurgists, obtained a patent for a process of gold extraction involving the use of bromo-cyanogen with the regular cyanide process. They claimed for their process greater rapidity and higher percentage of extraction in the case of complex ores than could be obtained with the McArthur Forrest method alone. In Vol. III, pp. 202-224, of the Transactions of the Institution of Mining and Metallurgy, Mr. Sulman gives an extensive list of results obtained on complex ores. These results

were favorable to the process, which under the name of Diehl, has been successfully applied and now seems to be a well established method of gold extraction.

The only late contribution on the subject, so far as the writer has been able to find, is the article by E. W. Nardin which appeared on October 31, 1908, in the *Mining and Scientific Press*, to which the reader is referred for a detailed statement of the technical application of the process. In Vol. I of the Proceedings of the Chemical and Metallurgical Society of South Africa (1894) there appears an interesting discussion of a paper by H. L. Sulman, who believed that he had found in bromo-cyanogen a substitute for the slowly acting oxygen of the air necessary in the McArthur-Forrest process. The reaction underlying the latter, called Elsner's equation, is as follows:

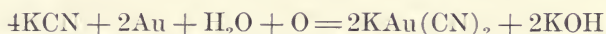

Mr. Sulman gives the reaction for his process as follows:

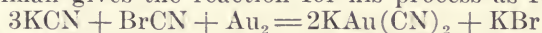

Not only Mr. Sulman's process, but his reaction as well, seem to have met with a reception more sarcastic than friendly, judging from the discussion which followed. J. E. Clennell did some work on the process in an attempt to solve the reactions occurring and gave the following as suggesting what happens:

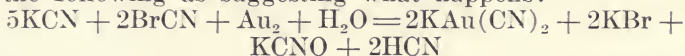

However, he did not wish to be understood as asserting positively that the above is the reaction in the case. He experimented qualitatively only on KCN and BrCN solutions in which gold was not present at all.

The article by Nardin gives the Sulman equation in explanation of what is, as the author puts it, "supposed" to happen. A knowledge of what really happens seems desirable, and so far as I have been able to ascertain, it has never been determined. Herewith follows a brief outline of some work done with this end in view.

Chemically pure BrCn was first prepared as follows (Ber. 1896, Vol. 29, pp. 1822-25): A solution of 65 grams KCN of 98% in 120 c.c. water was cooled to 0° C. and added drop by drop with shaking to 150 grams bromine covered with a little water. The temperature of the bromine should not be allowed to rise above 30° C. Add the KCN until the Br becomes yellow. Then distill the pasty mass at 65° C. This will give white crystals of c.p. BrCN. The crystals so prepared were placed in solution in water. This solution, of about 2%, was found to be stable.

Finely divided gold, purified by repeated precipitation with oxalic acid, was used in all the work. The KCN was 98 per cent.

To a measured quantity of 0.5% solution of KCN, was added the finely divided gold in large excess and air was drawn through the solution from six to eight hours, for the purpose of keeping the gold agitated and supplying the necessary oxygen to carry out Elsner's equation. The solution was then filtered and the gold washed. The solution so obtained was made up to 500 c.c. and an aliquot

part taken to determine the amount of KCN consumed. This was done by titration with silver nitrate. The remainder was treated with sulphuric and oxalic acids to precipitate the gold. The precipitate was then collected on filter-paper, dried, burned, the residue being fused with mixed alkali carbonates to which had been added a little flour and sheet lead. The fused mass was leached with water and the lead button cupelled for gold. Similarly, to another measured quantity of the KCN solution were added the gold and a measured quantity of the BrCN solution, the whole being then agitated intermittently from two to four hours. The amount of BrCN added in every instance was such that it contained less cyanogen than was present in the KCN solution taken (Sulman's suggestion). The solution was then made up to some definite quantity, generally 500 c.c., as in the first case. Then 250 c.c. was taken for the determination of gold and 100 c.c. titrated for the cyanide consumption.

A statement of some results is appended: In the first case the solution was approximately 0.5%; in the second case a solution slightly different was taken. In the first case 50 c.c. was taken, and in the second 250 c.c., made up to 500 c.c. in each instance:

	KCN consumed, c.c.	Weight of gold in aliquot part, grams.	Total weight of gold grams.	Weight of gold per c.c. KCN consumed, grams.
First solution, with air	26	0.0252	0.0504	0.00193
First solution, with BrCN	37	0.0680	0.1360	0.00370
Second solution, with air	90	0.0830	0.1035	0.00115
Second solution, with BrCN . . .	86	0.1018	0.2036	0.00236

From the above it will be seen that twice as much gold is dissolved with the same amount of KCN when bromo-cyanogen is used instead of oxygen of the air. In explanation of the above the following reaction is suggested:

$2\text{KCN} + \text{Au}_2 + 2\text{BrCN} = 2\text{KAu}(\text{CN})_2 + \text{Br}_2 = 2\text{AuCN.Br.KCN}$
the proportions in Elsner's equation being

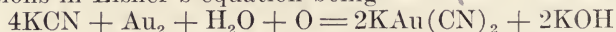

According to *Bull. de Soc. Chem.*, Ser. 1, pp. 29-416 (Paris), $\text{KAu}(\text{CN})_2$ forms absorption-products readily with the halogens, which explains the formation of the AuCn.Br.KCN suggested above.

In closing, it may not be amiss to call attention to the fact that the simple addition of bromine to cyanide solutions when treating ores cannot be substituted for the bromo-cyanogen process in practice, for the reason that to give a good yield of BrCN the temperature must be near freezing, otherwise oxidation products and consequent loss of Br and KCN will result. Also for every molecule of KCN.AuCN present already in the solution, there is a probability of loss of a molecule of bromine by absorption, and thereby temporarily, if not permanently, putting it out of commission without having accomplished its intended purpose.

CYANIDING SILVER ORE IN HONDURAS

By GEORGE E. DRISCOLL

(March 13, 1909)

At San Juancito, Honduras, the New York & Honduras Rosario Mining Co. has recently changed the system of ore treatment from pan-amalgamation and concentration to an all-slime filter-press cyanidation system, concentration and amalgamation being discontinued entirely. As the ore is of a kind that a few years ago would have been considered unsuitable for treatment by cyanide, and as the results have been successful, a description of the changes made in the reduction plant and in the process may be of interest.

The ore is dumped over grizzlies at the mine, the coarse going to a sorting floor. It is washed and the waste rejected. The large pieces are crushed to about one inch, dropping from the crushers into a bin. The crushed ore is loaded into tram-buckets for delivery to the mill. The wash-water carries a large amount of slime in suspension, and to recover it, lime is added, the water being then settled in vats. The capacity of the vats at the sorting plant is not sufficient completely to settle all the slime produced by washing the ore; the overflow carrying away an extremely fine and light material, amounting to about $2\frac{1}{4}$ tons per day of 12 hours. This is collected at the mill and is treated apart from the ore.

At the mill the tram-buckets empty into a hopper above the ore-bin, from which the ore is drawn into a car and is weighed before being emptied. The car employed holds about 1400 lb. From the bin the ore passes by inclined chutes into Challenge automatic feeders at the stamps.

The stamps are 50 in number and weigh 750 lb. each when newly shod. The drop is 6 inches, 100 to 102 times per minute. The mortars are of the double-discharge type, with screens of 30-mesh steel wire-cloth. The stamp-duty is 2 tons per stamp per day of 24 hours. The ore is crushed in cyanide solution. Under the former system of treatment the pulp from the batteries flowed to two sets of pointed boxes; the classified product being concentrated on 12 Wilfley tables, the coarse product from the first box passing over an amalgamated copper-plate. Lime is added to the pulp after leaving the batteries.

The overflow from the last boxes was formerly conveyed to two conical bottomed settling-boxes with bottom-discharge, which de-watered and thickened the pulp for concentration; the tailing from the slime concentrators was also elevated by a centrifugal pump and passed over 12 canvas tables. The tailing from the canvas and Wilfley tables was all conveyed to a 4-in. centrifugal pump and elevated to a launder which discharged into the pan settling-vats, the coarse sand being first separated and fed to two Smidt tube-mills. The sand from the tube-mills was re-concentrated, the material settling in the vats was treated by pan-amalgamation, and the slime overflowing from the settling-vats, amounting to 15 or 20 tons daily, was conveyed to the cyanide plant.

This treatment was costly and complicated, while the best extraction obtainable was 86%. In the summer of 1907 the company decided to adopt the cyanide process exclusively, and a 60-leaf slime-filter was purchased from the Charles Butters Co. The cyanide plant was enlarged to treat the entire output from the mill. On March 8, construction being completed as far as possible, with the works in operation, the mill was hung up to permit the final work to be done. The mill was stopped only six days; except for stops for a few trifling changes of a mechanical nature, which were made after starting, the mill has run constantly since, and the process has been pronounced a success.

The ore is crushed through 30-mesh screen in cyanide solution, and flows in wooden launders to a 4-in. centrifugal pump which elevates the pulp to three conical classifiers. The coarse sand is delivered to two tube-mills; the slime overflowing from the cone goes to two circular wooden settling-vats with peripheral overflow. The clear solution overflows into a vat to which is connected a 3-in. centrifugal pump; as the solution accumulates, the pump is started and the solution is raised to the mill-tank, from which it flows by gravity to the batteries to be re-used. From the tube-mills the sand is returned to the cones for classification, the final product going to the cyanide plant. This consists of material of which 90% will pass a 200-mesh screen. About every hour the slime in the settling-vats is drawn off and discharged by gravity into a wooden launder, which conveys it to the cyanide plant. This consists of seven circular wooden agitator-vats, and two receiving vats, into one of which the pulp from the mill flows. The approximate capacity of the agitator-vats is 50, and of the receiving vats 90 tons each of dry slime. The pulp from the mill flows into one of the receiving vats, cyanide being added as the tank is filling, so that when filled the solution will be brought up to 0.2% strength. From the receiving vats the pulp is transferred to one of the treatment-vats, where it is agitated from 40 to 60 hours before going to the filter. While being agitated, aeration is accomplished by circulating the pulp with a 6-in. centrifugal pump one hour, twice a day.

Samples of the pulp and solution are taken from the agitator-vats twice daily. These are filtered, the solution titrated, and, if needed, cyanide is added by suspending a perforated tin can, filled with this salt, in the pulp.

The exceedingly fine slime from the washing of the ore proved to be difficult to handle and required a large space to settle it. Attempts were made to utilize pan tanks in the mill, but without success. The only available method was to settle the slime in stone tanks below the mill, where it was de-watered, partly sun-dried, and returned in wheelbarrows to the mill. There it receives a preliminary treatment by agitation in solution in pans and settlers before going to the cyanide plant with the mill slime.

The pulp from the agitator-vats is pumped to one of two filter-vats immediately above the filter-box, into which it flows by gravity. When the filter-leaves are covered, the vacuum pump is started and

clean solution is drawn out until a cake of the thickness of $\frac{3}{4}$ to 1 in. has formed on the filter-leaves. A valve on the suction pipe is then opened, reducing the vacuum to about 5 in., which is found sufficient to hold the cake on the leaves. The surplus pulp is pumped out of the filter-box, returned to the vat, and the filter-box is re-filled with barren solution. The valve is then closed and cake given 40 min. solution-wash, which is followed by a 20-min. water-wash, after which the vacuum-pump is stopped, water is admitted to the filter-leaves, the cake drops off, and is discharged through a 10-in. pipe from the bottom of the filter-box. The time required for handling a charge is about 2 hours, the charge varying from 12 to 18 tons. The filter is operated by one native workman per shift.

After being in use about three months, an incrustation of lime forms on the filter-leaves, rendering them almost impermeable. To remove this the leaves are immersed in a 2% solution of hydrochloric acid, experience here having demonstrated that an immersion of 1 hr. in an acid solution of that strength is sufficient to entirely remove the lime, and to leave the canvas soft and clean. On being removed from the acid bath the leaves should be washed thoroughly until the acid is entirely displaced; otherwise the canvas will be quickly destroyed. It was found also that leakages in the leaves first occurred under the wooden ribs, and it has been found beneficial to sew a 4-in. strip of canvas under the ribs, this reinforcement adding indefinitely to the time a leaf may be used before undergoing repairs.

Precipitation is accomplished by means of zinc shavings, cut on the premises, six-compartment boxes being employed. The precipitation from the solution may be regarded as perfect. The zinc in the head-box is packed and replenished from the next box daily, the zinc being moved up, and new zinc added to the lower box. The boxes are cleaned out every three or four days, depending upon the richness of the ore treated. The precipitate and the solution from the boxes flow in launders to the sump-vat, into which they are washed through a 40-mesh screen. At intervals the agitator in the vat is set in motion, the pump is started, and the precipitate and solution pumped through a small 40-frame filter-press, formerly used for filtering slime. When the press is full it is opened, the precipitate shoveled into sheet-iron cars and run into a drying-furnace. The cars are usually left in the dryer over night, and a fire is kept burning until the moisture has been reduced to 3% or less. On being removed from the dryer, the precipitate is spread on a cement floor. The entire lot is then passed over $\frac{1}{8}$ -in. mesh screen, after which it is weighed into lots not exceeding 770 lb. The different lots are carefully sampled and put into oiled canvas sacks, which are boxed and shipped to New York.

The plant produces about four tons of precipitate per month, a force of four laborers and one shift-boss being required to attend to the zinc-boxes, cleaning-up, drying, sacking, and boxing of precipitate. The solution entering the zinc-boxes contains an average of 14

oz. silver and 0.12 oz. gold. The out-going solution contains merely a trace of gold and seldom exceeds 0.08 oz. silver.

Sodium cyanide of 127% strength is used exclusively. After the plant had been in operation a few weeks, potassium cyanide of 98% strength was tried, but the results were so unfavorable, in extraction and precipitation, that the use of it was discontinued. A two days' trial sufficed to show the superiority of the stronger sodium cyanide.

In the six months ended October 31, 1908, the plant treated 14,529 tons of ore of an average content of 40.05 oz. silver and 0.467 oz. gold. The tailing averaged 3.43 oz. silver and 0.019 oz. gold. The difference between the actual and theoretical extraction during this period was less than 1%. The cost of material, including zinc, cyanide, lead-acetate, hydrochloric acid, and lime, was ₱5.21, or, at the present rate of exchange, slightly less than \$2 gold per ton. The chief item of expense was cyanide, the large amount consumed per ton of ore treated (almost 8 lb.) being due principally to four causes: moisture in the ore and slime, amounting at times to over 10%, which decreases the strength of the solution: to cyanide consumed in dissolving the precious metals; to the presence of cyanicides in the ore, the most active of which are antimony and copper; and lastly, to loss in precipitation. This last amounts to approximately half a pound of cyanide per ton of solution passing through the zinc-boxes.

As the treatment-costs at present closely approximate the costs when pan-amalgamation and concentration were employed, the advantage of using the cyanide process lies chiefly in the lower labor-cost and in the higher extraction. As the material this plant is treating is a hard quartz, containing—in addition to the gold and silver—lead, copper, iron, and antimony, the results attained should aid in a revision of the opinions held by many writers, that silver ores are not readily amenable to treatment by cyanidation.

CYANIDATION AT MERCUR, UTAH

By LEROY A. PALMER

(May 1, 1909)

The first cyanide mill in the Western Hemisphere was built at the Mercur mine, in Utah. The Consolidated Mercur, successor to the original company, built what was for a number of years the largest straight cyanide plant in the world. The development of the process for this company forms an interesting chapter in this branch of metallurgy, and although larger plants have since been erected, many text-books still devote space to Mercur practice as exemplifying the most successful method of treating certain classes of ores.

The ore in this district is porous and friable, prone to slime excessively, and it causes much trouble on this account. In fact, the first attempts at cyaniding were a flat failure, because, when

crushed to the size supposed to be necessary, the pulp formed a thick slimy mud which the solutions absolutely refused to penetrate. Slime has always been troublesome. Recently an extensive slime-plant, embodying many new features, has been installed, and has brought the problem nearer to a satisfactory solution than hitherto. The mine furnishes two classes of ore, one oxidized, and the other base, owing to the presence of sulphur and arsenic. These two classes are broken separately, and dumped into different pockets at the Golden Gate incline, where they are hoisted to the crude-ore bins in two 4-ton skips, working in balance. These bins are of steel, well braced by steel beams and columns.

The progress of the base ore through the mill is as follows: Passing over a grizzly the oversize goes to a No. 6 Gates gyratory crusher, which reduces it to pieces that will pass a 3-in. ring, and discharges to the crushed-ore bin beneath. To effect distribution in the bin the crusher-discharge can be turned into a bucket elevator, dumping to a chute that sends it to the farther end of the bin. In the front of the crushed-ore bin are seven gates, through which the ore discharges into a chute leading to a large hopper set over an 18-in. inclined belt-conveyor, which carries the ore to a set of 14 by 36-in. Allis Chalmers A (Gates) rolls. These rolls discharge to a second set of the same size, and those in turn to a third set, 14 by 24 in. The third set discharges to the No. 1 elevator, which dumps to a wire-cloth trommel having three meshes to the inch, thus allowing a free opening of about $\frac{1}{4}$ in. The oversize from this trommel goes to a second, with openings three one way by one the other in each square inch, giving a free opening about $\frac{1}{4}$ by $\frac{7}{8}$ in. The oversize from this trommel goes to a fourth set of rolls, 14 by 24 in., discharging to the No. 2 elevator, which dumps to the bin without screening. In the chute to each set of rolls is a screen of the same mesh as the second trommel. These take out the undersize, which goes to the No. 2 elevator. Owing to the nature of the ore, crushing is done dry. All other elevators are 14 in. with 6 by 14-in. cups, spaced 20 in. from centre to centre. The bins are all of steel, well reinforced by 9-in. I-beams placed both vertically and horizontally. Below the bins are three floors containing the roasters, five in number, three of the Jackling type, one Brown, and one Holthoff, each having a capacity of 70 tons. The crushed ore discharges through the steel gates to a conveyor running in front of the bins, which in turn discharges to another traveling at right angles and over the feed end of the furnaces, which are arranged two on a floor, except on the second floor, where there is only one. The base ore is discharged to a large hopper, from which it is fed to the furnace by plunger-feeders. The Jackling furnace, designed by D. C. Jackling, who is now manager for the Utah Copper Co., is the most successful of the three types, and embodies practically the same principles as the others. The furnace is of brick, with fire-brick lining, 100 ft. long, 16 ft. wide, and 3 ft. high at the sides, with an arched roof rising 8 in. An endless chain carries 6 beams with 22 scrapers. The scrapers keep the ore rabbled, and

at the same time draw it slowly forward. On each side are two coal-fed fire-boxes in which a blast from a fan aids in maintaining the desired heat, and a steam-jet directs the flame downward upon the ore. The sides are well provided with cast-iron doors, permitting ready access to any part. By the time the ore has been dragged the length of the hearth, which is 100 ft., the sulphur and arsenic are expelled, when the roasted ore is discharged, and is picked up by an elevator consisting of beams each of which carries five cups. This dumps it on the cooling-platform, about one foot above the furnace. Here it is slowly scraped back, being turned and exposed to the air in the process, until just before it reaches the end at which it is fed it passes under a spray of water, and is discharged by a screw to the belts that carry it to the bin above the leaching-floor. For the last fiscal year the cost of roasting, including maintenance and repairs, was \$1.217 per ton. As will be seen later, this figure was made under disadvantages, including a fire which destroyed a large amount of coal, all of which was charged to the roasting-department.

From the crude-ore bins on the oxidized side of the mill, the ore passes over a grizzly and through a No. 6 Gates crusher, reducing it to 3-in. size, and discharging to the crushed-ore bins. From these, 7 gates discharge to a hopper over an 18-in. horizontal conveyor which dumps to a set of 14 by 36-in. Allis-Chalmers A rolls, the product from which goes to a similar set of 14 by 24-in. rolls, discharging to the No. 1 elevator. This elevator dumps to a 3-mesh trommel, which sends the oversize and undersize to separate bins. In each roll-chute is a screen similar to those used on the base-ore side, and the undersize from these screens goes to the No. 2 elevator to be dumped with the fine ore. The coarser ore contains pieces as large as 1 in., but they are so porous that the solutions permeate them without difficulty, and it has been found that fully as good an extraction is made on these sizes as on the material more finely crushed. This coarse ore, ranging in size from $\frac{1}{4}$ to 1 in., is discharged through the gates to a conveyor parallel to the bin, which dumps to another running to a chute, terminating at a bin beside that which receives the roasted base ore. On the leaching-floor are 26 rectangular steel vats, 48 by 24 by 4 ft., with the usual cocoa matting and canvas filter-bottoms, and 8 circular discharge-openings, 12 in. diam., with drop doors underneath over a series of four parallel tramway tracks. The three stock-solution tanks set on the next floor above the vats give a good pressure for forcing solution from below, if necessary. Each stock-tank is circular, of steel, 20 ft. diam. by 12 ft. deep.

The leaching vats are charged by tramming from the bins, each vat being filled to a depth of 2 ft. with the coarse oxidized ore, and the remaining 2 ft. with the roasted fine. Thus the coarse ore forms a filter for the fine, allowing the solutions to percolate thoroughly without packing. The vat being filled, 1500 lb. of lime is sprinkled over the top, and a 2-lb. KCy solution is turned on from below. When this has covered the top it stands for a few hours before

being drawn off. The usual practice of aerating is found to be a disadvantage, causing the ore to pack, and preventing the free circulation of the solutions. As fast as the solution is drawn from the bottom, more is run on the top, so as to keep the ore continually covered at a uniform depth. Two days after the strong solution is first turned on it is replaced by the weak wash (1 to $1\frac{1}{2}$ bl. KCy per ton), and the charge is treated with this for three days. This is followed by a two days' treatment with wash-water, and the tanks are then discharged by shoveling through the doors to tram-cars, which are hauled to the dump by horses. The consumption of lime is 6.85 lb. and of cyanide 0.7 lb. per ton of ore treated. The strong solution, when drawn from the leaching vat, runs to an 18 by 12-ft. circular steel tank from which it is pumped to three 14 by 8-ft. circular steel tanks, where zinc fume is added. The pumping serves to agitate the solution, and this is further accomplished by air under pressure from a simple 10 by 14-in. motor-driven Ingersoll-Sergeant compressor placed on the sump-floor. The zinc-gold solution is drawn off to 11 Johnson filter-presses, each $7\frac{1}{2}$ by 2 by 2 ft., the filtered solution from which runs to the sump and is pumped back to the weak-solution stock-tank. The zinc consumption is $\frac{1}{3}$ lb. per ton of ore. Working beside the filter-presses is a standard type of zinc-box, 17 by $2\frac{1}{2}$ by 3 ft., divided into 7 compartments. This was installed as an experiment, and has been so successful that the management is contemplating changing to this method of precipitation. The weak gold-solution is collected in an 18 by 12-ft. circular steel tank, and without precipitating the gold it is pumped back to the strong-solution stock-tank, and cyanide is added to bring it up to a strength of 2 lb. per ton. Two 5-in. geared Gould rotary pumps handle the solutions.

The slime-system is as follows: All oxidized ore that passes through the 3-mesh trommels goes into its own bin, and is drawn through the gates to be mixed at once with strong cyanide solution. This washes it to the separators and classifiers. The first stage is to pass it successively through two so-called 'mixer-separators'. Each of these consists of a box 20 by 3 by 3 ft., having a grade of 1 in. per foot. In the box is a longitudinal shaft, having two blades set every 6 in., similar to the blades of a ship's propeller. This shaft slowly revolves, working the ore upward as a screw-conveyor, while the solution tends to wash it toward the end of the box. The coarser particles offer sufficient resistance to the current to work out at the head of the box by the action of the screw, but the finer wash out of the opposite end to a second similar device, where the process is repeated. The separation of the coarse from the fine and the mixing of the latter with solution, gives the device its name. The tailing from the second mixer-separator goes to a cone, and the overflow from this goes to the slime-tanks, and the settling discharges to two Dorr classifiers. The Dorr classifier is a box with an inclined bottom 15 ft. long, 2 ft. deep, and $4\frac{1}{2}$ ft. wide at the upper by 4 ft. wide at the lower end. The grade is the same as for the mixer-separators. Lengthwise in each box are two shafts,

each carrying at intervals of 5 in. a toothed scraper-blade, 3 in. deep. These scrapers are actuated by a crank, with 10-in. swing, connected to each shaft. The scrapers are drawn forward along the bottom, then raised and pushed back 10 in., to be drawn for-

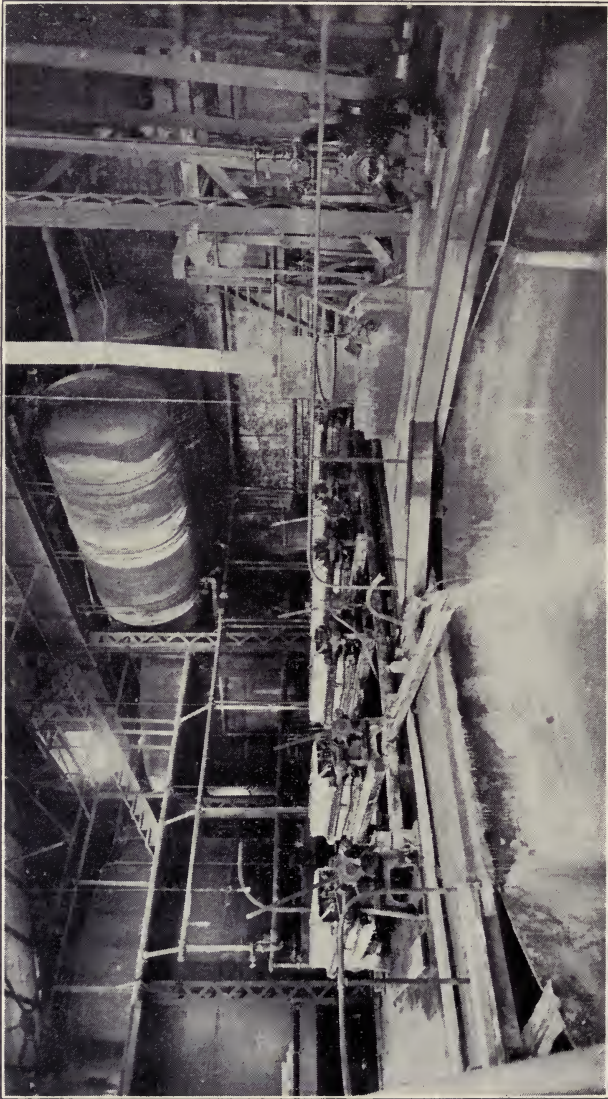

Fig. 50. FILTER-PRESSES AND SOLUTION SUMP, MERCUR MILL

ward on the bottom again. The pulp is fed in about one-third of the length above the tailing-discharge, and is subjected to an action similar to that on the mixer-separators, that is, the heavier is

scraped out at the head and the lighter washed out at the tailing end. A treatment of the tailing on a second classifier completes the separation of sand from slime. The heads from all the separators and classifiers run direct to a leaching vat, where they are treated as described above. The tailing from the last classifier runs in solution to three circular steel vats 30 by 8 ft. In each vat is a decanter, consisting of a perforated 5-in. horizontal pipe 6 ft. long. This is connected to two vertical pipes, passing through the bottom of the tank. This decanter is set on the opposite side of the tank from the feed-inflow, so that the slime may have an opportunity to settle and leave the decanted solution clean. Part of this decanted solution is re-used by mixing with the ore, and part is run to the precipitating room to be treated with zinc-fume. Agitation of the slime is not attempted, and it is found that the gold goes into solution in 24 hours. The tanks were originally provided with agitators, which are now used to scrape the bottoms when discharged. When a tank has been filled with slime a centrifugal pump transfers the contents to a fourth tank of the same size, where the pulp is thickened and then run to a circular steel sump-tank 15 by 8 ft. A duplex beam air-pump discharges the contents of the sump-tank to three wooden tanks, 10 by 12 ft., from which the pulp runs by gravity to the filter-room. Here are four square steel tanks, 8 by 8 by 7 ft., with a cone-bottom 4 ft. deep, equipped with vertical stationary filters. Agitation is accomplished by pumping from the bottom and discharging at the top, thus allowing all of the solution to reach the filtering surfaces. The filtered solution flows to the precipitating-room, and when a tank is full of slime a gate-valve is opened in the bottom, the contents discharged, and the filters washed with a hose. The zinc-slime from the precipitating-room is taken to the refinery, where the zinc is dissolved in sulphuric acid. The solid residue is roasted in a furnace with three 30 by 60-in. muffles, fluxed, usually with borax glass only, and charged into the smelting furnace. This furnace is double, each side having a capacity of 60 lb. of the product. The roasting is done with coal as fuel, while for melting crude oil is used.

The mill is equipped with a machine shop having the usual complement of tools for a large plant, and a foundry where all but the largest castings are made. There is here a circular 36-in. furnace, with five 2½-in. tuyeres. Power is furnished by the Telluride Power Co., whose lines enter the camp at a tension of 40,000 volts and are stepped down to 5000 volts at the sub-station and to 220 volts at a transformer station at the mill. The water is pumped from Ophir canyon, seven miles distant, by the Gold Belt Water Company.

The figures which the management publishes concerning operating expenses during the last fiscal year are doubtless a better criterion as to present cost of production than an estimate that could be made by one not closely in touch with the operations, but it is hardly fair to judge by the year in question, because during that time an unusual amount of development was done, including open-

ing some old stopes directly under the immense mill-dumps. Also, for a large part of the time production was made by only a fraction of the plant. During the period mentioned the average value of the ore was \$3.77, all in gold, of which \$2.85 was recovered. Mining costs averaged \$1.65 per ton, and milling costs \$1.27, or a total of \$2.92. A loss of 7c. per ton of ore treated was therefore sustained. For the current year it is hoped to bring the costs to the point previously reached, namely, \$1.41 for mining and \$1.07 for milling, a total of \$2.48. These figures include all executive and administrative expenses. The slime-plant, as installed, was experimental, and its capacity is not up to that of the mill, which has tended to keep the tailing up to the high figure of 92c. During the time that the mill handled a tonnage in proportion to the slime-plant, the tailing averaged only 46c. per ton. A feature that has caused much perplexity, and which is being experimented upon, is that the slime from the roasted base ore is not amenable to the same treatment as that from the oxidized ore.

About $4\frac{1}{2}$ miles below Mercur, at Manning, is the mill of the Manning Leasing Co., working on the dumps of the old Mercur mill. Here are 700,000 tons of tailing, of an average value of over \$2 per ton. The method used is that of the Holderman Process Co. of Salt Lake City. Near the mill a tunnel for tram-cars has been driven into the dump, and bins constructed. Slip-scrapers drag the ore and dump it into a hopper leading to this bin, from which it is trammed to the mill-bins by hand. From these it is fed to two 6-ft. Chilean mills, one Akron, and one Monadnock, and is crushed in solution. Each mill has a capacity of 120 tons. The ore is crushed so that 80% passes a 60-mesh and the remainder a 40-mesh screen. Without separation of sand from slime the pulp is run to the first tier of vats, of which there are 18, each 18 by 6 by 4 ft., with a bottom sloping from back to front with a pitch of 2 in. per foot. The tanks used in the Holderman process have filters on the bottom, sides, and ends, and 34 suspended filters in each 18-ft. tank. These suspended filters are merely canvas sacks over slotted pipes through which the solution can be drawn off. The use of these gives a filtering surface to every 6 in. of length in the tank, and allows the solutions to quickly reach every ore particle. When the process was first tried, agitation was used, but this has proved unnecessary, and has been abandoned.

In the front of each tank, and flush with the bottom, are three discharge-gates with launders running to the second tier of tanks. After treating in the first tank with a solution of 1 lb. excess alkalinity per ton, the pulp is flushed with clear water to the second tank, the water with the solution left in the pulp, making the proper strength of weak solution. In the second tier are six tanks, 18 by 6 by 7 ft., with the 34 filters submerged 2 ft. below the surface. The entire time for percolating and leaching is 18 to 24 hours, after which the vats are flushed out. Both strong and weak solutions are collected in a sump, and are pumped to the gold-solution tank at the top of the mill by a centrifugal pump. This tank is 16 ft. diam.,

with 17 suspended filters to prevent slime getting into the zinc-boxes in case a filter in one of the leaching-vats should break. The solution is brought to standard in this tank, and is passed through a zinc-box 18 by 2½ ft. The precipitation is so nearly perfect that the tailing from the zinc-box does not show even a trace of gold. This precipitation takes place in the first three compartments. For the present the precipitate is being shipped, but a refinery is to be built in a few months. The extraction of the soluble values is 97%, with a consumption of 0.35 lb. KCy per ton, and a zinc expense of 1¾c. The Chilean mills are driven respectively by 35 and 50-hp. motors, the latter driving also a centrifugal pump delivering solution from the zinc-boxes to the stock-solution tank. One 5-hp. motor runs a centrifugal pump elevating solution from the sump to the gold-solution tank, and one 5-hp. motor drives a rotary pump for sluicing. Power is taken from the sub-station at Mercur. It is transmitted to Manning at 5000 volts and transformed at the mill to 440 volts. Springs furnish about 115 tons of water (30,000 gal.) per day. Each ton of ore requires 300 to 500 lb. of water.

The plant is designed for 240 tons per diem, and when run at full capacity, treatment costs can be brought down to 60c. per ton. During the winter, owing to the fact that the dump is frozen, and that the mill-bins have not sufficient storage capacity to provide against contingencies, only about 140 tons are being treated, at a cost of 70c. per ton. For assistance in obtaining data for the above description, the writer wishes to acknowledge indebtedness to George Dern and Tom Fergusson, manager for the Mercur and Manning companies, respectively.

MINES AND PLANTS OF THE PITTSBURG SILVER PEAK

By HENRY HANSON

(May 8, 1909)

The mines and plants of this company are situated at Blair, Silver Peak mining district, Esmeralda county, Nevada. The company at the beginning of the present operations constructed a standard-gauge railroad 17½ miles long, connecting Blair with the Tonopah & Goldfield railroad. The district is one of the oldest in the State, and for the past forty years has produced a considerable amount of high-grade ore, which was hauled by wagon to the town of Silver Peak, where it was reduced in small plants. The mines had been almost idle several years, when the advent of the railroad and electric power line, resulting in cheaper milling, induced the present company, after the purchase of the Blair property and the consolidation of the Mohawk-Alpine group, to begin operations on a large scale. The mines are situated 2.7 miles from Blair. All machinery is electrically driven, power being furnished by the Nevada-California Power Co. The compressor-plant consists of one 8-drill, 2-stage, Ingersoll-Rand compressor and one 2-stage, 25-drill, Nordberg. The motor driving the latter machine is of the General

Electric 2-speed type. The mines are provided with a complete machine shop and all modern conveniences.

The orebody dips about 30°. The ore is mined and trammed to large loading chutes, from which it is transported by electric motors to the crushing plant at the upper terminal of the tramway. The cars have a capacity of three tons each. They are built with rigid frames, and are dumped automatically. Two cars may be dumped at once. The tippie is actuated by compressed air, one cylinder throwing in the holding dogs, unlatching the side door, and throwing the cars into dumping position. The crushing plant consists of one No. 6 and two No. 3 gyratory crushers. The ore is crushed

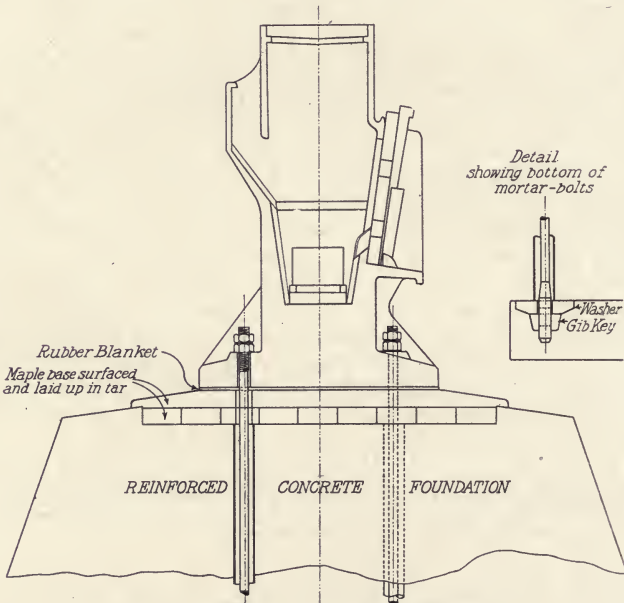

Fig. 51. MORTAR FOUNDATIONS

in two stages to pass approximately a 1-in. ring. From the secondary crushing the ore is elevated and passes through the automatic sampling machines. The discard goes to the 400-ton tramway bin, where it is loaded automatically into the tramway buckets, which have a capacity of 800 lb. The tramway was built by A. Leschen & Sons Rope Co. It has a length of 14,000 ft., with a total fall of 1600 ft. The capacity at normal speed is 450 tons per 16 hours. The ore is delivered to the mill storage bin, where the buckets are dumped automatically into a receiving hopper, from which it is taken by a 24-in. Stevenson-Adamson conveyor running the entire length of the 4000-ton mill storage-bin. This conveyor is provided with an automatic traction-dumper.

After thorough testing for a process suited to the ore, it was decided to use the Merrill system for the secondary treatment. The

present mill-site was selected in order to obtain a gravity plant. Nothing was spared in the design, construction, and equipment to make the mill and its auxiliary departments a model in every way. Steel and concrete were used in the mill construction. The machine shop is at Blair, and has an equipment of machines and tools heavy enough to do all mine, mill, and railway repairs. The wood-working department is also complete with necessary machinery.

In the store department is a full and complete line of mine, mill, and railway supplies, and repair parts, machine extras, and so forth.

The 100-stamp mill is of the usual type, containing, with 1050-lb. stamps, driven in units of 20 stamps each, by five 50-hp. Bullock motors. The stamps drop 96 times per minute, with a fall of $6\frac{1}{2}$ to $7\frac{1}{2}$ inches. The mortars are of special design, having massive bases with large area and are held in place by means of eight foundation bolts. The manner of installation is shown in the illustration. The heavy reinforced concrete foundation is provided with a 6-in. built-up maple coping, surfaced perfectly true and laid in tar. This coping is carefully cemented in place and provided with heavy rubber blankets between its top and the base of the mortar. The large cast-iron pedestal bases which receive the battery posts are also mounted upon the maple coping. The bottom of the mortar-bolts has the bolts enlarged with a keyway $\frac{9}{16}$ in. wide, which receives the gib-key as indicated. This gib-key engages the foundation washer as shown. Placed in the foundations so as to secure clearance in case it is necessary to remove the bolts, are pieces of 3-in. pipe. This type of construction has given excellent satisfaction, diminishing the usual failures of battery parts due to crystallization, which is invariably the case where mortars are mounted directly on a concrete foundation. The duty of the stamps, while it varies somewhat with the ore, will average four tons per stamp in 24 hours through a 35-mesh screen. The drop of the stamps, originally 105 per minute, with a $6\frac{1}{2}$ to $7\frac{1}{2}$ -in. fall, was reduced to 96 per minute, the fall remaining the same. This change reduced both the repair and power cost, and did not reduce the tonnage. That there should be no decrease in tonnage on reducing the number of blows of each stamp over 8% can only be accounted for by the fact that there was not sufficient time intervening between the rapid blows to allow sufficient ore to lodge on the die to gain the maximum efficiency from each blow. Crushing is done with 5 to 6 parts of water to 1 of ore. Outside amalgamation is used. The plates have an area of 12.8 sq. ft. per stamp, and are set on a grade of $1\frac{1}{4}$ in. to the foot. The water supply is pumped from Silver Peak through 17,000 ft. of 6-in. standard pipe, against 550-ft. head, to a steel storage-tank 30 by 22 ft. deep placed behind the mill at an elevation of 40 ft. above the battery floor. For this service is used a heavy 7 by 12-in. Platte Iron Works single-action direct-connected triplex pump. Water in the battery tank, 20 by 16 ft. deep, is maintained at a constant level by a float-valve, operating automatically, and is supplied by the storage-tank mentioned above.

and also by overflow from clarifying and sand tanks. A third tank, 20 by 16 ft. deep, furnishes water for sluicing out sand and slime tailing, and is supplied by returning the clarified sluicing water from slime-presses, as well as part of the water overflowing from the sand tanks while filling, and also the barren waste solutions.

The tailing, after passing the amalgamating plates, is conveyed to the distributing sump of the clarifying department in a wooden launder 12 in. wide by 8 deep, set with a grade of $1\frac{1}{8}$ in. per foot. The bottom of the launder is covered with $\frac{1}{4}$ -in. steel plate. A triple is employed in this launder, through which the tailing may be temporarily turned to waste when necessary. Before entering the distributing sump the tailing passes through a screen box fitted with $\frac{1}{2}$ -in. steel trommel plate perforated with 7-mm. holes. This screen removes all wooden chips and coarse rock due to breaks in battery screens. The distributing sump, 3 ft. diam. by 4 ft. deep, with a baffle-board, has two adjustable gates, which provide an even pulp-feed to each of the two settling cones. These cones are 8 ft. diam., with the sides sloping at an angle of 50° . The stream of pulp is fed to the centre of the cone through a sump 12 in. square projecting 12 in. below the water-level. To the apex of each of the settling cones is bolted a multiple outlet casting, tapped to take four $1\frac{1}{2}$ -in. pipes. Each of these pipes feeds one of the sizing cones. The sizing cones are 4 ft. 3 in. diam. at the point of overflow, and have sides sloping 70° . The pulp-feed is introduced at the centre of the cone through an enlarged elbow submerged below the water-level to prevent all agitation. The sizing cones are fitted with the Merrill patented hydraulic sizers, by means of which a rising stream of clear water is caused to meet the falling sand. The water, being supplied at a low pressure, enters in such a way that no eddies or cross-currents are produced. A thorough sorting is thus effected, the slime passing upward and overflowing the lip of the cone, while the coarse and fine sand pass out at the bottom discharge. Both settling and sizing cones are fitted with lead leveling strips to insure a uniform peripheral overflow. Special cocks and nozzles fitted with chilled-iron bushings are used to regulate and equalize both the feed and discharge of the sizing cones. The mill-tailing is thus divided into two products—slime, the combined settling and sizing-cone overflow, and sand, discharged from the bottom of the sizing-cones. The following figures as to the sizing of these products may be of interest:

	On 60 mesh, %	On 100 mesh, %	On 200 mesh, %	Through 200 mesh, %
Mill tailing	22.98	23.55	13.33	40.12
Classified sand	29.86	32.68	24.09	13.37
Slime	1.46	98.54

The tailing before classification, as has already been said, contains from 5 to 6 parts of water to 1 of solid. The sand after classification contains from 3 to 4 parts of water to 1 of solid, and the slime from 14 to 16 parts.

Lime is added to the sand in amounts varying from $2\frac{1}{2}$ to $3\frac{1}{2}$ lb. per ton. The lime is crushed wet in a 1-stamp battery through an 8-mesh screen. The manner of crushing causes the greater bulk of the lime to collect in unslaked granules, a fact that makes it possible to maintain a practically uniform protective alkalinity. The sand is then conveyed through wooden launders to the leaching tanks, where it is distributed by a mechanism of the garden-sprinkler type. These machines, two in number, are suspended from carriages on a track, and can be moved to any of the five leaching tanks. They were designed to insure an absolutely uniform distribution of the fine and coarse sand throughout the charge, preventing all possibility of channeling during the subsequent direct treatment.

The leaching tanks, five in number, are 36 by $11\frac{1}{2}$ ft. deep, and have annular launders to carry away overflow during the filling. The filter-bottom consists of 2 by 4-in. pine placed on edge and spaced 2 in. apart, over which is spread a cocoa-matting and 8-oz. canvas filter. Each tank has a capacity of approximately 500 tons of sand, and under present conditions will fill in about 40 hours. When a tank has been filled, the drain-valve at the bottom is opened, and the water in the saturated sand is allowed to drain. The drainage period requires about 14 hours, after which the treatment begins. This consists of alternating periods of air and solution, each air period being preceded by a drainage period. The unprecipitated standardized strong stock-solution is used during the earlier stage of the treatment. This is followed by a barren or precipitated weaker solution, which is in turn followed by wash-water, used to displace the remaining gold-cyanide solution contained in the charge. The treated charge is then sluiced out through four side gates and one centre gate. One man with two 3-in. pipes with $1\frac{1}{8}$ -in. nozzles discharges a tank in about four hours. The water required for this purpose is approximately one ton to one of solid, including the water in the saturated sand. The whole cycle of treatment from charging to charging, at the present rate of filling, occupies a little over seven days.

The effluent solution from the sand charges is divided into three classes—'weak', 'strong', and 'low'. The 'weak' is the solution from the early periods of treatment, and flows to the weak or precipitating sumps, from which it is precipitated by being pumped through the precipitating press to the weak-solution storage-tank, thus becoming the barren precipitated solution which is used on the leaching tanks during the latter stages of treatment. The 'strong' solution is largely the effluent displaced by wash-water, and flows to the strong-solution sump-tank, where it is standardized to the normal strength and pumped to the strong-solution storage-tank. The 'low' solution is the combined effluent from the first and final stages of treatment, low in cyanide, and kept at a sufficient tonnage to maintain the normal balance of solution in the plant. The sump tanks, four in number, one strong, one weak, and two low, are all 26 ft. diam. by 10 deep.

The combined overflow from the settling and sizing cones flows into a distributing sump with adjustable outlet gates similar to those mentioned in connection with the sand. From this sump five 'U' or round-bottomed galvanized-iron launders distribute the pulp to five clarifying or de-watering tanks. These are 26 ft. diam. by

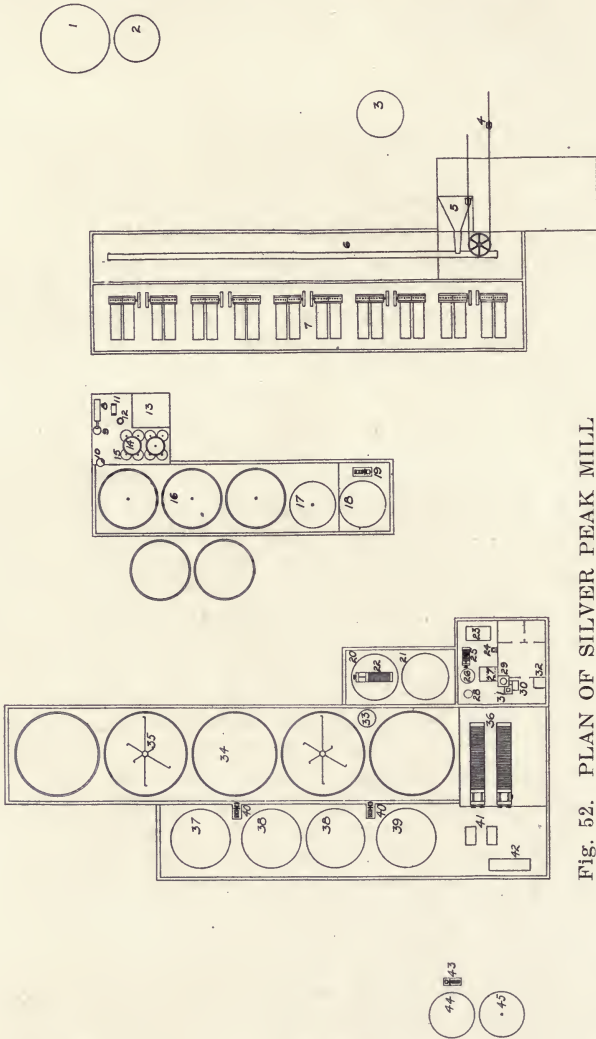

Fig. 52. PLAN OF SILVER PEAK MILL.

24 ft. 2 in. deep, built with a wooden cone-bottom sloping 45 degrees. Each tank has an overflow launder bolted to the inside of the tank. The thickened slime as drawn continuously from an outlet at the bottom of the cone, contains from two to three parts of water to one of slime, and flows directly to a sludge storage

tank or accumulator, 20 ft. diam. by 16 deep, with a 45° wooden cone-bottom. The clear water overflowing the clarifying tanks is conveyed to a sump-tank 20 ft. diam. by 16 deep, from which it is

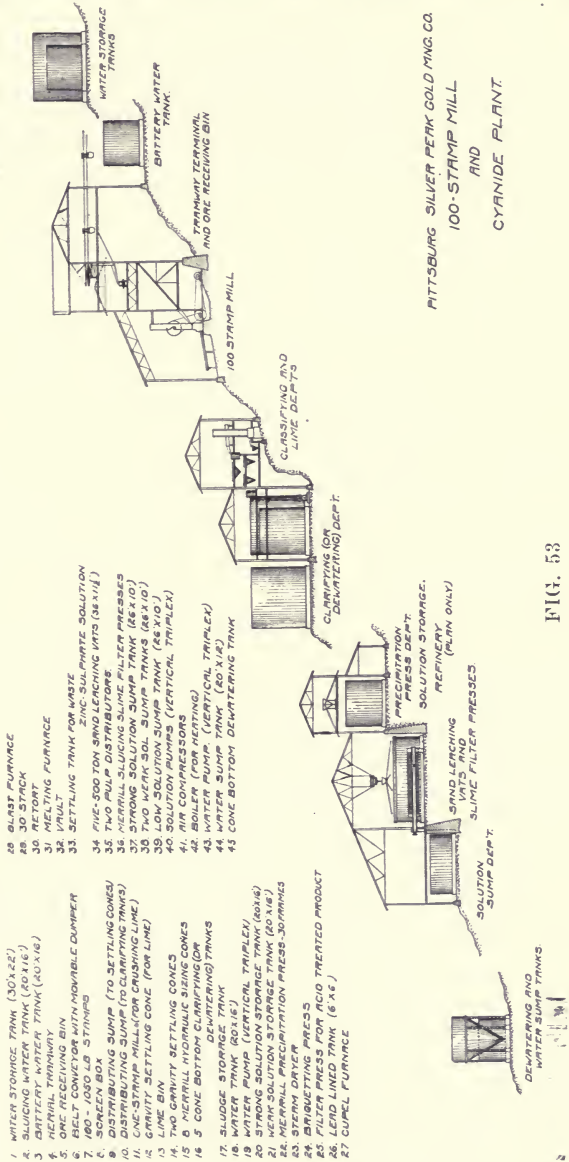

FIG. 53

pumped direct to the battery storage-tank back of the mill by a 9 by 10-in. Aldrich triplex pump. Sufficient cyanide and lime are added to the sludge storage-tank to make a solution of 0.025% cyanide

with a slight protective alkalinity. The pulp is agitated constantly by air, and is drawn at regular intervals directly to the two filter-presses. The slime-presses are of the well known Merrill type,* containing 64 four-inch frames, filled from a 6-in. pipe under 30 lb. gravity pressure, and discharged without opening by means of the rotating sluicing pipe with water under 60 lb. pressure. Owing to the talcose nature of the Silver Peak slime, the usual method of direct treatment in the presses has been somewhat modified. Instead of filling the frames until a solid 4-in. cake has been formed, the slime-feed is shut off while there is still an opening of about $\frac{1}{4}$ in. at the centre of the frame. As the feed valve is closed, the solution or water valve is opened, and the leaching of the cakes begins from the centre outward, the water or solution being introduced to each frame through a sluicing nozzle or rotating pipe. While it is perfectly practicable to leach in the presses with a secondary solution, it is found that the gold in the slime, which occurs in a fine state of division, is fully dissolved in the sludge storage-tank. The main purpose of the presses, therefore, is to separate the dissolved gold from the slime. The displacement of solution by wash-water is satisfactory and complete, there being little tendency for slime to classify if the pulp is maintained at a reasonably high gravity. Approximately eight parts of water to one of solid are used in sluicing the presses, most of this water being recovered by settling in a cone-bottom tank 24 ft. deep by 20 ft. diam. The final slime residue going to waste averages about $2\frac{1}{2}$ parts of water to 1 of solid, and could be discharged easily at 1 to 1 if desirable by providing greater settling capacity.

Zinc-dust is used for precipitation, the Merrill patented triangular press and process being used. Two distinct solutions are handled, the weak solution from the sand tanks and the combined low solutions from the sand and slime. A 12-in. rubber belt-conveyor, mounted on suitable rollers, is arranged to operate by means of floats and counter-weights at a rate proportional to the volume of solution pumped from the tank. The dry zinc-dust, being spread uniformly along the belt, is discharged into a mixing cone at a rate proportional to the tonnage of solution to be precipitated. A jet of air agitates the emulsion, and a small stream of barren solution provides a constant overflow, which carries the zinc-emulsion down a $1\frac{1}{4}$ -in. pipe to the suction of the pump. No zinc is allowed to escape directly into the tank, and the precipitation takes place entirely during the passage of the solution through the pump, the pump-column, and the press. The latter contains thirty 2-in. triangular frames, 52 in. across the top, and has a total filter area of 450 sq. ft. The solution enters each frame from the top side channel and passes through a core to the bottom of the frame. Any zinc left in the frame from a previous pumping is kept in thorough agitation by the incoming stream of solution, and any excess of zinc

*'The Homestake Slime Plant', by Mark Ehle, *Mines and Minerals*, March 1907, and 'Cyanide Practice at the Homestake Mills', by F. L. Bosqui, *Mining and Scientific Press*, July 6, 1907.

deposited in the press during one pumping will be available for further precipitation during some future pumping. The efficiency of this method lies in the fact that the cloths are coated with a layer of powdered zinc and precipitate, so that every particle of solution having to pass through the cloth necessarily comes into intimate contact with the fine zinc, and also in the fact that to each tank of solution fresh zinc is added, assuring good precipitation, even of a solution containing copper. This can seldom be done with zinc-shavings, owing to their tendency to become inert when coated with copper.

The weak solution, after precipitation, flows to the barren weak-solution storage. The low solution is precipitated in like manner, but the barren 'low' flows to the water tank and is pumped to the sluicing tank, when it becomes the main supply for sluicing the slime-presses and sand tanks. One press serves for all solutions precipitated in the plant. It is necessary to clean the press twice a month. The cleaning and re-dressing with new cloths requires about four hours for two men. The filters used are changed at each cleaning of the press, but are washed and re-used several times. The following figures on precipitation are averages for March, 1909:

	KCy.	—Precipitation—	
	%	Gold. Head.	Gold. Tailing.
Weak solution	0.095	\$8.19	\$0.016
Low solution	0.025	0.85	0.020

The refining process used at this plant is practically identical with that in use at the Homestake.* Briefly, it is as follows: The precipitate is taken directly from the triangular precipitating press and placed in a lead-lined steel tank, where it is made into a thick sludge by adding water and agitating with mechanical stirrers. The free zinc is dissolved by hydrochloric and sulphuric, or by sulphuric acid alone. After acid treatment the sludge is deposited in a small filter-press. The zinc sulphate and other salts soluble in the acid solution or in water are carried away to a waste tank. Several washes of hot water are used after the precipitate is in the press, to make sure that all soluble salts are removed. The press is then opened and the acid-treated product is placed on a steam dryer, where it is dried sufficiently to be screened and sampled. After this a flux, consisting of litharge, borax, and ground coke, is added and mixed thoroughly with the precipitate. This mixture is then briquetted at a pressure of about 1000 lb. per square inch, the object being to avoid 'dusting'. The briquettes are melted in a cupel furnace. During the fusion the gold is thrown down in lead, while the slag is run off into pots and later re-run in a small blast-furnace, together with cupel bottoms, sweepings, and other by-products. The cupellation of the lead is carried on in the same furnace, and the lead is separated from the precious metals by blowing a light air current across the surface of the molten metal, thereby oxidizing

*'The Metallurgy of the Homestake Ore', by C. W. Merrill, *Trans. A. I. M. E.*, October 1903.

the lead, which is drawn off from the front of the cupel as rapidly as it is formed. The litharge takes out very little value, and is re-ground and used the following month as flux. The bullion from the cupel furnace is then cut up and re-melted in graphite pots and cast into bars for shipment. The amalgam from the stamp-mill, after retorting, is melted and cast into bars in the same manner.

All men employed in mill and cyanide plant work 8 hours. The regular mill-crew consists of 3 men on a shift. In addition to this number are 2 plate-men and 2 repair-men on the day shift, making in all 13 men for the 24-hr. day. In the cyanide department 4 men are employed on each shift, with no extras on the day shift, making the total cyanide crew 12 men for the three shifts. In the refinery 2 men are employed, on day shift only. Their work consists of cleaning the precipitation-press and carrying on all work connected with the refining of mill and cyanide products. In the assay office, where the assaying for the mine and plant, as well as some custom work, is done, 3 men are employed.

Below will be found tabulated costs per ton of ore milled for six months, including office, administration, and insurance expense, but not interest and depreciation of plant:

COST PER TON

Month.	Milling.	Cyaniding.	Assaying.	Refining.	Total.
October	\$0.932	\$0.772	\$0.068	\$0.070	\$1.842
November	0.913	0.681	0.072	0.113	1.779
December	0.773	0.677	0.079	0.095	1.624
January, 1909.....	0.760	0.630	0.062	0.159*	1.609
February	0.595	0.583	0.067	0.106	1.351
March	0.564	0.496	0.053	0.058	1.171

*Refining costs high this month, due to making a general clean-up of the solution sump-tanks, in which a gelatinous precipitate had been deposited while using brackish water from a salt marsh, which contained sulphates and carbonates.

These milling costs, as far as known, are less than one-half those of other plants operating under conditions found in Nevada. The following figures relative to the cost of labor, power, and water for the entire milling plant (mill and cyanide) furnish an interesting comparison with similar data published of other Nevada companies:

Month.	Labor.	Power.	Water.	Total.
October	\$0.594	\$0.236	\$0.194	\$1.024
November	0.488	0.237	0.110	0.835
December	0.451	0.237	0.100	0.788
January, 1909	0.433	0.213	0.103	0.749
February	0.374	0.199	0.080	0.653
March	0.389	0.198	0.081	0.668

The cost of chemicals per ton of ore treated for the same months were as follows:

Month.	Cyanide.	Zinc.	Lime.	Acid.	Total.
October	\$0.221	\$0.058	\$0.047	\$0.033	\$0.359
November	0.190	0.046	0.047	0.030	0.313
December	0.194	0.044	0.044	0.021	0.303
January, 1909	0.176	0.060	0.037	0.060	0.333
February	0.160	0.036	0.032	0.025	0.253
March	0.106	0.017	0.036	0.013	0.172

For the last quarter of 1908 and the first quarter of 1909, 64,052 tons of ore were milled. The net Mint returns on the bullion shipped show a total recovery of 92.3% of the gross value of the ore. Of these recoveries, 66% were made on the plates and the remaining 34% by cyaniding of sand and slime. The method of treating the sand in the secondary plant is practically the same as that used at the Homestake, modified to suit the local conditions. In the selection of a process suitable to the ore, crushing in cyanide solution was carefully considered and rejected because of the importance amalgamation plays in the recovery, and the difficulty of maintaining amalgamation at a high efficiency when solution is passed over the plates. While some of the ore contains considerable lead and iron sulphide, and the presence of these, especially where the lead and iron sulphides occur jointly, are excellent indications of good assay-value; the concentration of the sulphides, however, does not materially concentrate the precious metals. Concentration is, therefore, impracticable. By fine grinding, a small additional recovery, dependent on the grade of the ore, could be obtained. This, however, would necessitate the installation of a re-grinding plant, and also more slime-presses, and it is not considered that the additional recovery would justify such an installation on a comparatively low-grade ore. George O. Bradley was employed by the company during the construction and erection of this work.

SHORT-ZINC

(April 3, 1909)

The Editor:

Sir—In your issue of February 13, page 246, you refer to the ill effects of iron present in zinc used for gold-precipitation purposes. This opens an interesting subject. The phenomenon of 'short-zinc' so-called—the rapid crumbling or disintegration of zinc-shaving—has been observed under varying conditions. My own observation would point to its being due in most instances to the presence of iron, not, however, so much in the zinc itself as in the solution, and in the material of the zinc-box. I do not think the small amount of iron in the better grades of commercial zinc can be appreciably detrimental. The worst case of short-zinc I ever saw was in a plant where I was treating a deposit of old oxidized tailing, full of soluble iron salts. The solutions were reddish brown in color. Here the consumption of zinc was alarming, while zinc supplied by the same firm was perfectly satisfactory in other cyanide plants in the same district. In the case referred to, the shavings would become so brittle after an immersion of an hour or two in the solution, that they could be compressed in the hand into a hard compact mass of short-zinc. This was doubtless due to the galvanic action set up between the zinc and the iron. I have seen zinc crumble badly in boxes made of iron, where, at exposed points not covered by protective paint, a small line of bubbles could be seen issuing from the unprotected surface. The complex chem-

ical reactions and galvanic phenomena of zinc-precipitation have not received as much attention from cyanide chemists as they deserve—possibly because, as a rule, in practical work precipitation offers no serious difficulties. Until this subject is more definitely understood it may spare the operator some trouble if he will remember to keep zinc and iron as far apart as possible in his precipitation-boxes. In the meantime it would be interesting to know something more of the experience and researches of metallurgists in zinc-box work.

F. L. BOSQUI.

San Francisco, February 24.

(May 8, 1909)

The Editor:

Sir—In your issue of April 3, F. L. Bosqui touches upon several interesting subjects in his letter on 'Short-Zinc', and I trust you will be able to induce him to publish in full his information on those subjects. The iron in solution, which he speaks of as acting galvanically upon the zinc, causing brittleness and an abnormal consumption, must have been present as a ferro-cyanide compound, and I am surprised to hear that galvanic action took place between such a salt and metallic zinc. A different explanation of his phenomenon might be given if it were known how much free cyanide, alkali (NaOH or $\text{Ca}(\text{OH})_2$), and precious metal was present in the solution being precipitated; also the percentage of ferro-cyanide compounds. Furthermore, was the precipitation taking place in steel or in wooden boxes? Large zinc-consumption occurs from other causes than galvanic action, one of which is an extremely rich solution. I have frequently had more than 60% of the zinc in the head compartment consumed in 24 hours when precipitating very rich silver solution, a great hole being left in the centre. I would like to hear the result of Mr. Bosqui's experience in the comparative effect upon precipitation in the use of steel and wooden precipitation-boxes: It would also be of interest if your other readers would contribute their experience on that subject. According to Mr. Bosqui, I take it, wood should be used in preference to steel as material for the construction of zinc-boxes.

H. T. WILLIS.

Parral, Mexico, April 14.

(May 22, 1909)

The Editor:

Sir—In the discussion on short-zinc which has appeared in recent issues of the *Mining and Scientific Press*, one cause of the trouble has not been touched. The presence of even a very small amount of mercury in solution will render the zinc fragile. The mercury is precipitated from solution on the zinc, with which it amalgamates, and causes its disintegration. As most of the old tailing available has resulted from the treatment of ores by amal-

gamation, they generally contain some floured mercury. On weathering, this finely divided mercury becomes mercuric oxide, which dissolves at once in cyanide solution. 'Short-zinc' and poor precipitation often follow from the use of dilute solutions containing no or very little free alkali. In one case coming under my observation, cyanide treatment followed directly after stamp-milling and amalgamation. Milk of lime was continuously added to the stream of pulp after it left the plates, and the sand was caught in collecting vats. After draining, the sand was transferred to leaching vats, and a first solution run on. The sand contained some concentrate (sulphides) which oxidized readily, and it was noticed that the first solution drawn off was always acid, although there was a small excess of lime in the sand. The solutions which were drawn off subsequently were in good condition, and when mixed with the first solution, a bulky flocculent precipitate came down. This precipitate coated the zinc, and the precipitation of the gold was poor. By mixing the contents of the gold tank thoroughly and regulating the amount of free alkali in the solution, the precipitation became regular and satisfactory. In many cases it will pay to run the gold tanks intermittently, that is to say, to fill one gold tank with solution, and then turn the effluent from the leaching vat to another gold tank. The contents of the first gold tank should then be agitated and brought to a suitable condition for precipitation. In most cases this will mean the addition of the proper amount of lime or caustic soda to give that degree of alkalinity to the solution which proves most favorable to precipitation. After allowing suspended matter to settle, or after filtering it off, precipitation of the gold and silver will take place under the most favorable conditions, and 'high' sump-solution need no longer be feared.

A very interesting article by A. J. Clark appeared recently in the *Journal* of the Chemical, Metallurgical and Mining Society of South Africa (Vol. 9, p. 222), in which a comparison of results and costs in precipitating by zinc shavings and zinc-dust is given. The results quoted by him show that the cost of zinc-dust precipitation is much less than precipitation by shavings. This paper is well worth the attention of the users of zinc shavings, and should cause them in many cases to try to improve their practice. The proper equipment of the precipitation and clean-up departments in plants where zinc shavings are used has received too little attention, and in many cases only the most perfunctory care is taken of the precipitation, with the result that much zinc is wasted and the cleaning up of the boxes and melting of the bullion is unnecessarily laborious and costly.

BERTRAM HUNT.

San Francisco, May 11.

(May 22, 1909)

The Editor:

Sir—In your issue of April 3, F. L. Bosqui speaks of short-zinc and brittle zinc as though the two were the same. There is an

important distinction between the two, and the causes which give rise to their formation are quite different. Those who have had experience in the treatment of old pan-amalgamation tailing are quite familiar with brittle zinc, and understand the important part it plays in the precipitation of gold from the solutions, particularly from those containing copper derived from the bluestone used in the old Washoe process. The brittleness is due entirely to the quicksilver which is recovered from the tailing and precipitated on the zinc. Within a few hours from the time the solution is turned into a freshly packed box, the shavings in the upper compartments turn white and become so brittle that a large mass can be compressed into a small compact ball. The precipitation of the quicksilver is so complete that in a 16-ft. box of nine compartments only the three upper ones will contain an appreciable amount of brittle zinc, the rest showing the brilliant hue of the copper which comes down after the quicksilver. When the zinc is thus coated with quicksilver the precipitation is complete. Boxes containing this kind of brittle zinc have to be looked after most carefully. My usual practice has been not to re-pack the compartments containing the brittle zinc until the zinc has practically disappeared. This point cannot always be determined by inspection, as the zinc often retains the outward shape and bulk of the original shavings.

There are probably other causes which give rise to brittle zinc, but I question their importance. Very often in cleaning up the boxes a certain amount of material of doubtful composition, having the outward form of shavings, will be found. This material is brittle and contains, among other things, certain zinc compounds formed by the replacement of a part of the original metal. This type of brittle zinc usually forms in badly packed boxes, where the circulation is poor and where the shavings have not been properly loosened previous to packing. I question whether this material can be properly classed as brittle zinc.

By 'short-zinc' I mean that which is discovered in cleaning up the boxes and which ranges from a fraction up to 3 or 4 in. long. The objectionable feature about this is that it refuses to be made up into a fluffy mass like long zinc, and if replaced in the boxes in any considerable quantity it will retard the flow of the solution, and will perhaps cause the box to overflow. The material can be given an acid treatment, or may be roasted, but both methods are objectionable. Short-zinc of this character is wholly unlike brittle zinc, and refuses to break up or permit itself to be made into a compact mass by mere pressure. It is my opinion that short-zinc is caused chiefly by the method employed in cutting the shavings. The greater portion of the zinc used is cut on lathes which do not produce shavings of uniform thickness. Furthermore, the lathes are so designed that in order to have a fair capacity they have to be run at such a speed that sufficient heat is generated to produce considerable oxidation. In designing a zinc-lathe, the problem is to transmit the power from the shaft on which the mandrel is mounted and around which the zinc is wound, to the screw driving

the cutting tool. The mandrel revolves at somewhat more than 100 r.p.m., while the screw is driven at less than 1 r.p.m. The usual practice is to cut the speed down by a ratchet and pawl movement. This method is effective and cheap, but it has the disadvantage of imparting an intermittent movement to the screw, which in turn causes the cutting tool to advance by jerks, so that the shavings produced are not uniformly thick. Ordinary observation will fail to disclose any variation in the thickness, for the reason that the shavings are extremely thin, but a little consideration will show that the point which I bring out is correct. Another fault with most lathes is that the mandrel around which the zinc is wound has not a sufficiently great diameter, and the zinc has not the necessary time to cool before it again comes under the edge of the cutting tool. Of still greater importance is the matter of reducing the speed of the mandrel. Many manufacturers advise running their lathes at a speed of 120 r.p.m. or more. I do not know of any lathe made, with one exception, which should be run at a speed greater than 90 revolutions, while 80 would give better results. The exception which I have in mind is one which is run under ideal conditions, with special precautions to keep down the temperature of the zinc. The lathe cost something like \$2000, so it is not likely to come into general use.

Not long ago I ordered a considerable quantity of cut shavings from a manufacturer, and on receipt of it I found that the shipment was made up of two lots. One of these had been cut on the expensive lathe of which I have just made mention, and the other on a lathe having an intermittent feed. This gave an excellent opportunity to compare the two kinds of shaving, so I had the zinc-boxes packed so that if there were any difference it would be clearly shown. Each pair of boxes had exactly the same grade of solution and the same quantity. On cleaning up, the box containing the zinc cut on the expensive lathe gave about four pounds of short-zinc, while the other yielded about forty-five. These results were in confirmation of a point which I had long maintained, namely, that the amount of 'shorts' produced depended upon the character of the shaving. It is a well established fact that where the shaving becomes heated during the process of cutting, so that a slight oxidation has taken place, the precipitation on those shavings will be imperfect, and I will add that an excessive amount of shorts will be produced in the boxes.

I believe that the points which I have dwelt upon have long been recognized by others, for a great many companies make use of precision machine-lathes for cutting zinc shaving. To cut them on these lathes it is only necessary to put a wooden drum on a shaft held in the chucks. The speed reduction on machine-lathes is obtained by gears and worms, which causes the cutting tool to advance at a constant speed, and this produces a shaving of uniform thickness. The high cost of lathes of this type makes it impracticable for small plants to install them, but it is advisable to do so where possible. All lathes employed for cutting shaving should

be carefully looked after and frequently babbitted to eliminate as far as possible all lost-motion. The slightest change from a perfect alignment will cause a serious variation in the thickness of the shaving cut by the machine.

The disposal of the 'shorts' after a clean-up is a serious matter. Acid refining is expensive and troublesome, and roasting is about as bad. The way I usually handle this material, if there be any considerable quantity, is to put it into a separate precipitating tank and run strong rich solution through it slowly until the zinc practically disappears. This method is employed in zinc-dust precipitation where rich solution is run through the presses previous to a clean-up. This is not applicable to zinc shaving in the regular boxes, for the reason that only 'shorts' would be left behind, as the long-zinc would dissolve first.

Short-zinc is not as active as a precipitating agent as long-zinc, and by careless handling during the clean-up operations its precipitating coefficient can be made zero. When the zinc is removed from the boxes it should be kept wet with either water or solution until it is replaced, and then it should be immediately re-covered with solution. When exposed to the air a rapid oxidation takes place and the zinc becomes hot. After this takes place, precipitation is slow and indifferent.

R. STUART BROWNE.

San Francisco, May 12.

AGITATOR FOR CYANIDE TESTS

By G. H. CLEVINGER

(May 29, 1909)

After designing and using several types of agitators, for making small cyanide tests, the writer has found that the machine herewith illustrated is the most convenient and satisfactory in every respect. It may be readily constructed in any mine-shop of ordinary equipment.

It will be noted that the machine is simply a series of large wooden rollers mounted upon a table or other suitable base. Large 2½-litre acid bottles are used as containers for the pulp; these are not filled over one-third full, or so that the pulp does not run out at the necks of the bottles when they are lying on their sides upon the rollers. By this method the agitation is effected in open bottles, and the annoyance of inserting corks is avoided. The test is made under conditions resembling treatment in an open tank. The wooden rollers are reinforced at their ends by means of iron bands; these serve the further purpose of preventing the bottles from working off at the ends of the rollers. Two idle rollers may be successfully used upon each side of the driven roller. Increased capacity may be obtained by making the rollers longer. Any source of power may be used, but for an agitator of moderate size, a small electric motor will be generally found to be the most satisfactory. The driven roller should run at a speed of 30 to 50 revolutions per

minute. At first, until the bearings become limbered up, it may be found necessary to place a couple of heavy rubber bands upon each bottle, in order to get the necessary friction for driving the idle rollers. Re-grinding tests may be readily made with this agi-

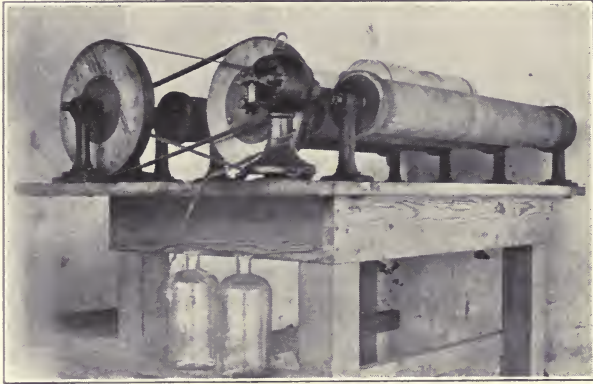

Fig. 54. AGITATOR FOR CYANIDE TESTS

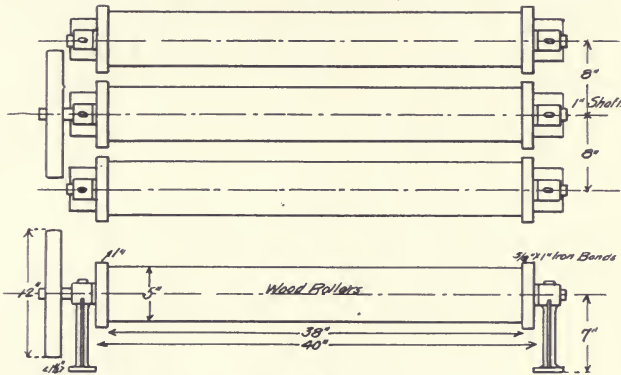

Fig. 55. DIMENSIONS OF AGITATOR

tator, by filling the bottles about one-third full of small glass marbles, before adding the ore and solution. In this case it is best to use corks, which should be carefully attached.

VACUUM SLIME-FILTERS AT GOLDFIELD

By ALFRED MERRITT SMITH

(July 10, 1909)

The Butters vacuum-filter plant at the Nevada Goldfield Reduction Co.'s mill at Goldfield, Nevada, is one of the earlier installations, and various methods of operation have been tried during the last four years, with a view to securing the most economical results. At the time the filter-plant was installed it was not deemed

practicable to erect the 'semi-gravity' type, whereby the stock-pulp is gravitated into and out of the filter-boxes as required from pulp-tanks placed respectively above and below the filter-boxes. The mill is situated on level ground, hence the filter-boxes were elevated quite high in order to secure sufficient dump-room for future accumulation of slime residues. About 12 ft. below the level of the filter-boxes is placed the one stock-pulp tank required, from which the pulp is pumped directly to and from the filter-boxes. The pumping is accomplished by a 6-in. Butters centrifugal pump, provided with the usual arrangement of valves for reversing the operation. The vacuum-pumps are two in number, of the Smith-Vaile 10 by 10-in. single type, and the working vacuum varies from 15 to 25 in. The filter-boxes are three in number, having 15 leaves each, 45 in all. Leaves of a special design by E. S. Leaver have been in use for over three years, the essential difference from the Butters leaves being that grooved wooden slats are used as a filling for the canvas leaf, instead of the canvas being sewed upon a cocoa-matting filler.

Assuming general familiarity with the operation of vacuum slime-filters of the modern type, I will briefly describe the evolution of our filter work here to the present stage. It is known in milling circles where slime-filters of the Butters make have been adopted, that there is a continual enrichment of the wash-water, or wash-solution, by osmosis, which in the filtration of high-grade slime will result in material losses of gold. For example, the cakes having been formed on the leaves and the excess of pulp returned to its tank, clean water is pumped or gravitated into the filter-boxes for washing, and the vacuum again applied to draw wash-water through the cakes. But this clean water coming into contact with the comparatively large area of slime-cake, pregnant with gold solution, immediately absorbs and diffuses a portion of the gold and cyanide. After the required amount of this wash-water has been drawn through the cakes by means of the applied vacuum, the excess of 'wash' is run back to a tank, to be used again for the same purpose, carrying with it an increment of gold and cyanide. This gold and cyanide in the wash is cumulative, increasing with each cycle of operation. The quantity of water necessary to replace that which is drawn through the leaves, and also that which is discharged with the residue in ordinary work, is not sufficient to prevent a gradual enrichment of the reserved wash.

It was our early practice here, when the wash-water had increased in assay value from nothing to about \$1.50 or \$1.75 per ton, to discharge the whole of it into the battery solution-tanks. As the original crushing is done in cyanide solution, this provided a way to save a part of the loss. A fresh supply of clean water was then taken in for filter-wash. This, however, did not save the cyanide and gold remaining in the wash-water which was necessary to run out the slime residue, amounting to several cents per ton of dry slime in treating the high-grade ores of Goldfield. Double washing was next tried. The cakes were first thoroughly washed

with weak barren sump-solution, the whole of the excess wash being returned to a separate tank. The boxes were re-filled with clean water, the vacuum applied for five minutes, to re-wash slightly, the cakes were dropped, and the excess of water returned to the water tank, enough water being retained to discharge the residue in the usual way. In theory this method seems almost perfect, as the loss of gold by osmosis is reduced to almost nothing, and the volume of working mill-solution is not materially increased by an additional five-minute water-wash. The objections were, first, a double exposure to the air and the washing action, frequently causes much of the cake to loosen and drop off from the leaves prematurely, and second, more time and pumping is necessary to complete a cycle of operations. The first of these objections is not serious, as it cannot overcome the primary object, that is, the prevention of gold loss by osmosis, for this is obtained by saving all of the first wash-solution, none of which is used to sluice out the residue.

The method now in use, which allows the filters to be worked at their full capacity, and at the same time minimizes the loss by osmosis, is as follows: The cakes being formed and the stock pulp returned, the boxes are filled with weak barren sump-solution and sufficiently washed. When the wash is completed, an excess of wash-solution is pumped back to a storage-tank, enough being retained to flush out the residue. The discharged residue is run into a tailing pond, settled, and clear solution is drawn off by means of a gate or weir, to a pit, from which it is pumped back to the mill, to be used again as filter-wash or as battery-solution. Clean water is run into the residue pond to the amount of fifteen or twenty thousand gallons per day, as a further wash, and to absorb and save a portion of the gold-bearing solution which remains in the residue. This water is returned to the mill, and is ordinarily sufficient in quantity to preserve the equilibrium of the mill-solutions.

Below is a sample copy of the record kept for each filter-box charge, showing the distribution of time in a complete cycle:

Charge No. 4987. Filter-box No. 2.	June 4, 1909.		
	A.M.	A.M.	Hr. Min.
Filling filter-box with stock pulp.....	6:25	to 7:13	21
Period vacuum applied	7:13	" 8:18	1 5
Pumping back excess pulp.....	8:18	" 8:35	17
Pumping on wash solution.....	8:37	" 9:00	23
Time washing	9:00	" 10:00	1
Dropping cakes	10:00	" 10:07	7
Pumping back wash	10:07	" 10:22	15
Discharging residue	10:22	" 10:27	5
Total time of cycle.....	3 hr. 33 min.		
Tons of solution from pulp.....	4.53		
Tons of wash through cakes.....	3.05		
Thickness of cakes	1 in.		
Specific gravity of stock pulp.....	1.21		

CYANIDATION OF SILVER ORES

By THEO. P. HOLT

(July 31, 1909)

Since the publication of some laboratory experiments on the above problem in the *Mining and Scientific Press* of April 17,* I have received a number of personal inquiries regarding the work, which

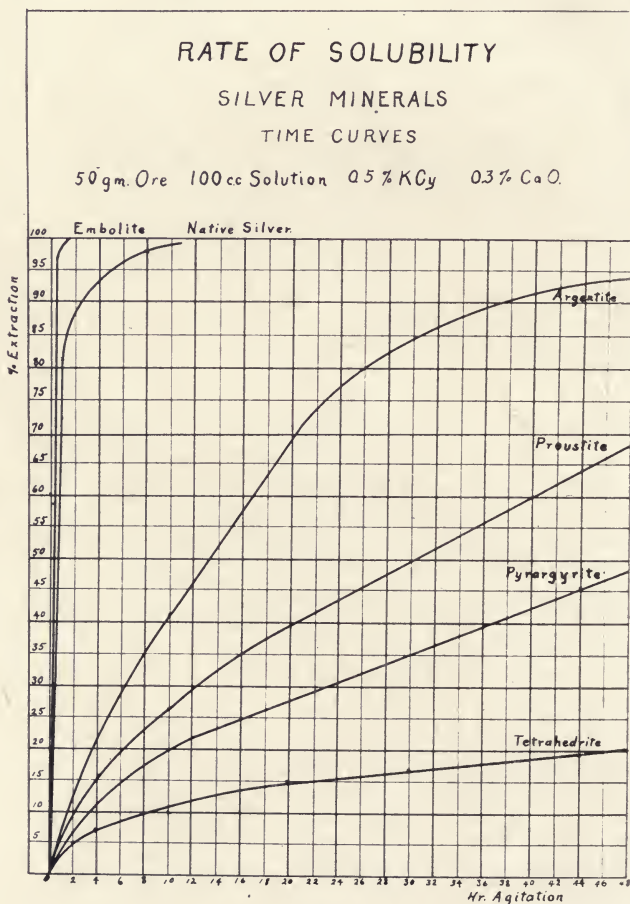

Fig. 56

would seem to warrant the submitting of more complete data. The general scope of the work, and also the method of conducting the tests, are discussed in the previous article. As far as practicable, I have endeavored to secure uniform conditions in the experiments from which the graphs have been constructed. The required weight

*This volume, P. 186.

of the silver mineral was in each case crushed with a little quartz sand, and passed frequently over a 100-mesh screen. It was then mixed with a sufficient quantity of pure quartz sand to make an 'ore' assaying approximately 50 oz. silver. This method of preparation favors the production of a large number of particles approaching the size of the maximum grain, which will in a measure offset

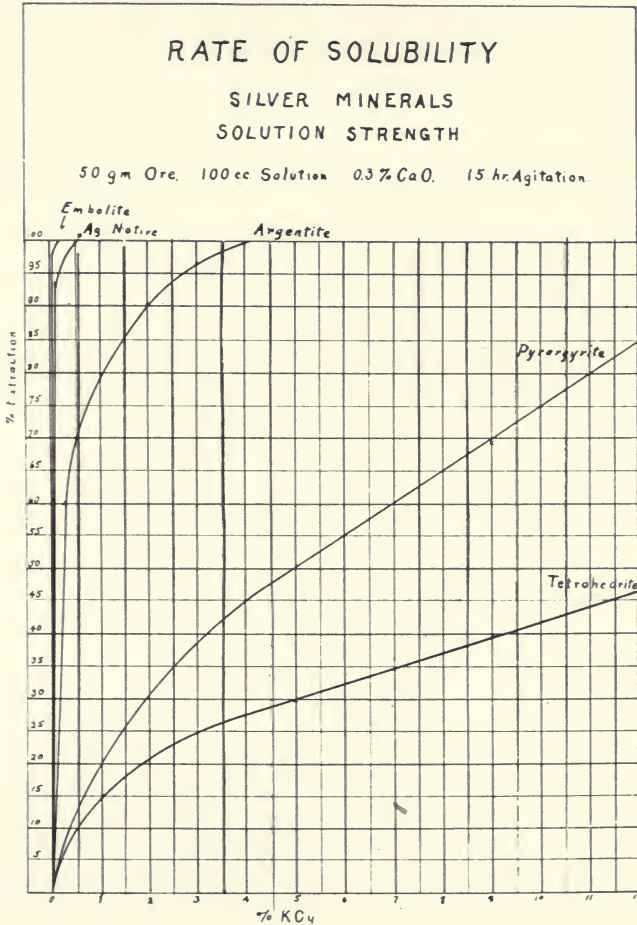

Fig. 57

the fact that none of the mineral is encased in the gangue. No doubt the surface of mineral exposed to the action of the cyanide solution is much less than obtains in modern slime-treatment practice.

Some statements have been made recently concerning the adaptation of bromo-cyanide to the treatment of silver ores. I find that in the absence of free cyanide it is not a solvent for the silver min-

erals. However, the addition of a limited quantity of bromo-cyanide to a cyanide solution is often quite efficient in increasing the extraction. This is doubtless largely due to the power of BrCy as an oxidizer. The bromo-cyanide used in these experiments was made by adding liquid bromine to a 0.5% KCy solution. The solution was kept cold by surrounding the flask with snow. When all the potassium cyanide has been converted into bromo-cyanide a permanent

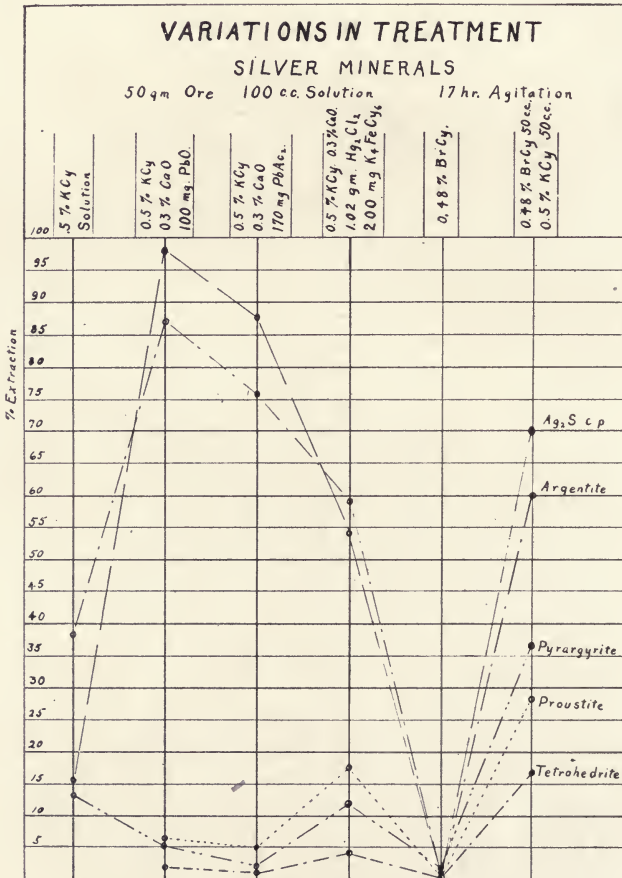

Fig. 58

yellow color appears. The strength of solution in BrCy is determined by titrating with a standard thio-sulphate solution. The absence of free cyanide may be assured by a drop of the silver nitrate standard.

A striking illustration of the difference of solubility of gold and silver in BrCy is presented by some results on sample No. 13 (see Fig. 60 and 61). This is a hard quartz-rhyolite from Mexico,

assaying 1.29 oz. gold and 56.80 oz. silver. The silver is nearly all present as argentite. Although this ore contained over forty times as much silver as gold, upon treatment with bromo-cyanide about one-third of the gold passed into solution, while not so much as a trace of dissolved silver could be detected. It is also remarkable

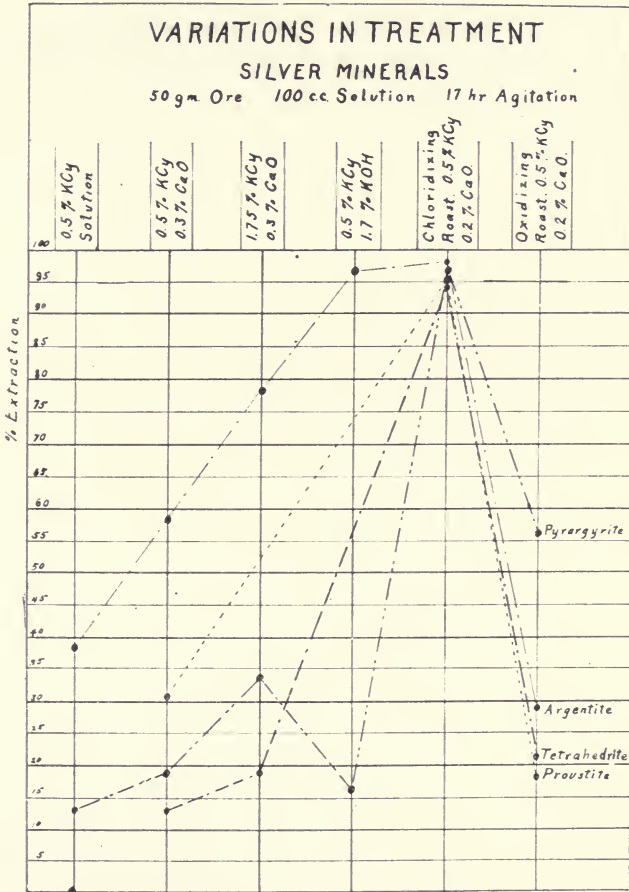

Fig. 59

how closely its silver content follows the line for argentite through the variations in treatment.

With certain of the silver minerals a chloridizing roast seems the only means of securing a satisfactory extraction. The graphic results were obtained on small samples mixed with 5% salt and roasted in an open muffle for one hour. A similar sample, without the addition of salt, was roasted at the same time. The temperature was taken every 20 minutes, and averaged above 700° C. It is evident from the graphs that a chloridizing roast is about equally effec-

tive in all cases, the silver being converted into a chloride which is very readily dissolved. It is probable that both the amount of salt, and the time of the roast could be materially decreased without reducing the extraction. For an oxidizing roast one hour is too brief a period materially to change the state of the silver.

Variations in treatment reveal some remarkable contrasts in

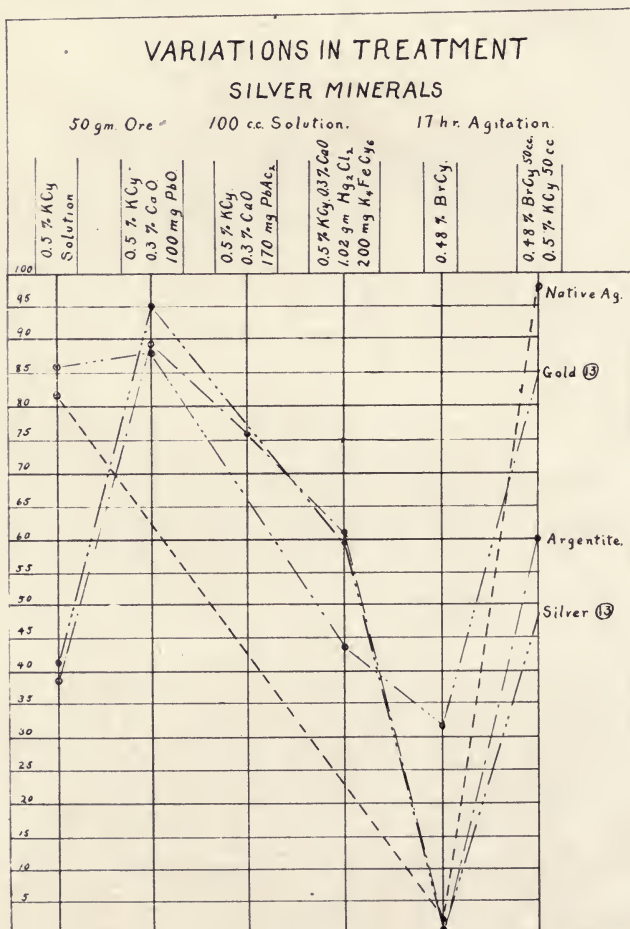

Fig. 60

the action of native silver and argentite. Louis Janin, Jr., published the first experimental results on the solution of silver sulphide and cement-silver in potassium cyanide.¹ He sums up this investigation by stating that "The extraction with silver sulphide is directly proportional to the strength of solution, and with cement-silver in-

¹Eng. & Min. Jour., Dec. 29, 1888.

versely proportional." With slight correction the data of his tables are given graphically in Fig. 63. A few years later these 'curious phenomena' were satisfactorily explained by J. S. Maclaurin when he established the fact that "The solubility of oxygen is greater in a weak than in a strong solution, and the amount of gold (or native silver) dissolved is proportional to the absorption coefficients of oxygen."²

A clear knowledge of the fundamental laws of chemistry is

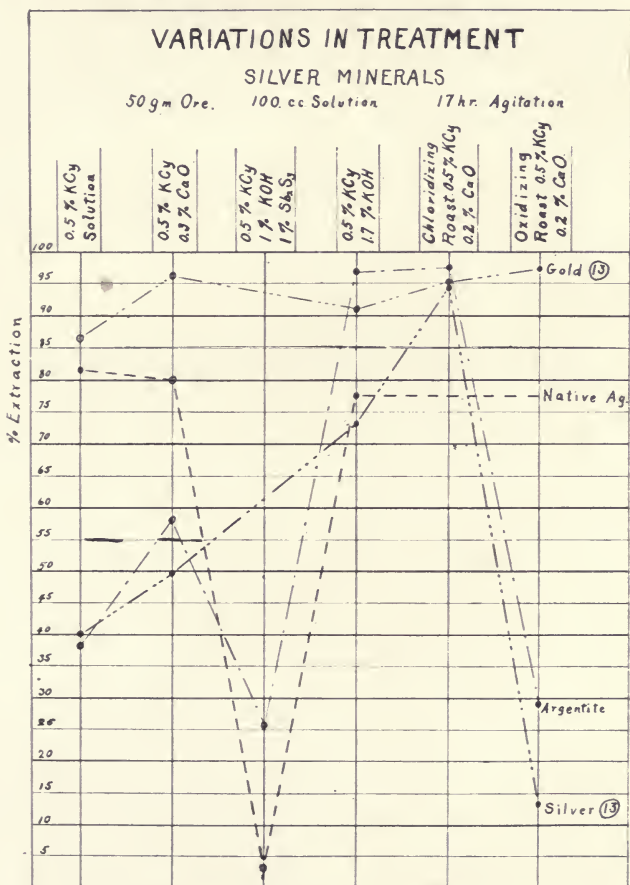

Fig. 61

essential to a correct interpretation of the experimental results. The theory involved in the solution of gold in potassium cyanide is discussed at length by S. B. Christy in his article on the 'Electromotive Force of the Metals.'³ A summary of these principles in

²Jour. Chem. Soc., Vol. 63, p. 724, and Vol. 67, p. 199.

³Trans. Amer. Inst. Min. Eng., Vol. 30, p. 864.

their application to silver is roughly as follows: there are two forces tending to drive the metal into solution: (1) the electromotive force of the silver in a cyanide solution, and (2) the ionizing tendency of the oxygen present. The electromotive force of the metal is the difference between its 'solution pressure' and the 'osmotic pres-

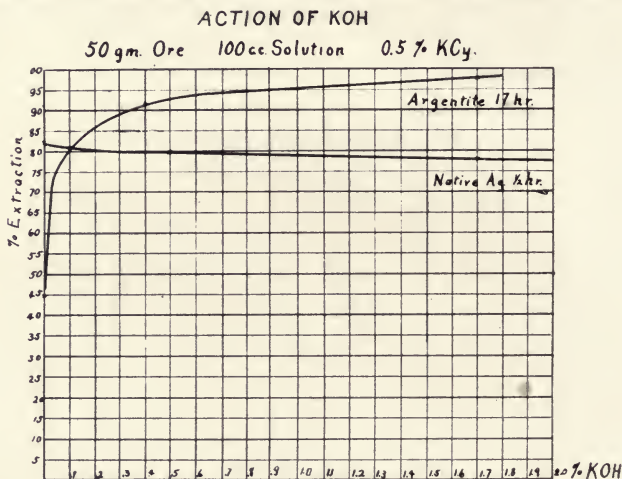

Fig. 62

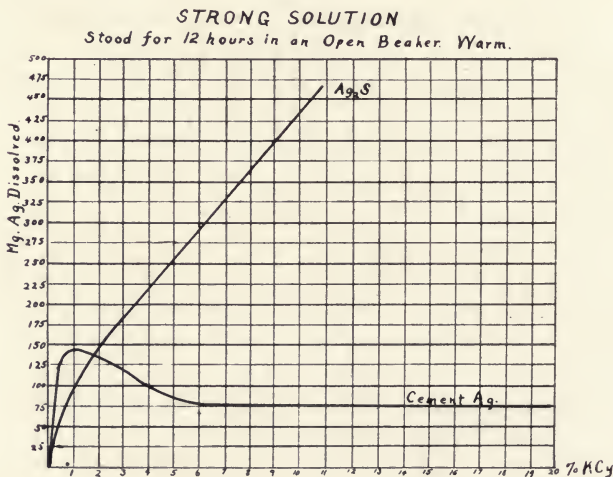
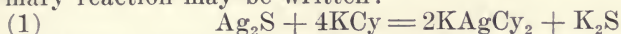

Fig. 63

sure' of its ions already present in the solution. But since the compound $KAgCy_2$ in solution dissociates extremely few silver ions, the electromotive force of silver in this case is high. The oxygen of the air may be replaced by the various oxidizers, or any electro-negative ion, as OH, Cl, or Br. Thorough aeration seems preferable to the introduction of special oxidizers.

The solution of argentite (Ag_2S) has been discussed recently by a number of writers in the *Mining and Scientific Press*. The primary reaction may be written:



This equation is reversible and incomplete, and owing to the fact that Ag_2S is so slightly soluble, proceeds only to a limited extent before equilibrium becomes established. Unlike the case on native silver previously discussed, the formation of the complex AgCy_2 ion does not remove a sufficient number of the argent ions to bring any considerable amount of the silver sulphide into solution. The ionic equilibrium existing in the above equation, as it effects silver sulphide, may be represented as follows:

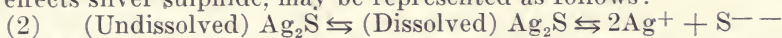

According to the law of mass action, we can cause the above equation to pass in the desired direction by removing either the silver ion or the sulphur ion from the solution. Both methods are practicable.

The silver ions present in a potassium argento-cyanide solution are due to the third step in the dissociation of this salt.

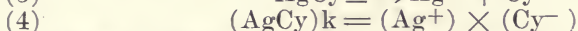
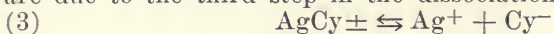

If no other salt dissociating either Ag or Cy ions be present in the above solution, the number of these ions is equal; but suppose an excess of KCy is added to the above solution; the result then is that the equality of (3) is disturbed, since the number of Cy ions has been increased, and the silver ions must combine with Cy ions to form undissociated $\text{AgCy}\pm$. Thus the silver ions present may be reduced to an infinitesimal number, and the solution of silver sulphide be allowed to proceed. This end is realized in practice by the use of strong solutions.

The removal of sulphur ions resulting from the solution of silver sulphide and other sources, is brought about by oxidation and precipitation as insoluble sulphides. The degree to which chemical salts are capable of influencing the amount of silver dissolved may be appreciated when we inspect the graphic results of a few tests. (See Fig. 59, 60, 61, and 62.) Take the line for argentite as an example. The 0.5% KCy solution dissolves 38% in 17 hours. The addition of 0.3% lime brings this up to 58%. By making the solution strongly alkaline with KOH, almost 97% of the silver is dissolved in the same time. A small amount (0.2%) of litharge is about equally effective. Litharge (PbO), although it enters the solution as a plumbite, still dissociates a sufficient number of Pb ions to effectively remove the S ions as insoluble PbS . Thus the presence of lead salts prevents the equilibrium indicated above being established, and the solution of silver sulphide proceeds. Any metal the sulphide of which is but slightly soluble in cyanide solution will produce a similar effect.

The increased extraction observed on adding potassium hydroxide to the solution is also in accordance with the mass law. In this case we have:

$$(\text{K}_2\text{S})_k = (2\text{K}^+) \times (\text{S}^{--})$$

Upon adding a highly dissociated salt, as KOH, we greatly increase the number of K ions, and hence the product on the right side of the equation. To establish ionic equilibrium some of the K ions must unite with S ions to form undissociated K_2S , and thus effectively removing S ions from the solution. From a practical standpoint the use of some metal to precipitate the sulphur in an insoluble form is much to be preferred, as any other method results in the fouling of the solution, by the accumulation of soluble sulphides.

I trust that this review of some of the fundamental principles of chemistry may be useful in the study of the experimental data. The reactions involved in most cases are complex, and only those which are quite elementary are indicated. I shall be pleased to receive suggestions or criticisms along the line of this work, and hope that further investigation may develop points of practical value for application in the process.

BROWN TYPE OF LABORATORY AGITATOR

By T. S. LAWLOR

(August 7, 1909)

The need of an efficient scheme of air-agitation in laboratory tests to parallel working conditions in cyanide treatment where agitators of the Brown or Pachuca type are to be used, led to the adoption of the apparatus described below. Fig. 64, opposite, shows a battery of five agitators that was used for a number of tests, with satisfactory results.

Agitators No. 1 and 2 were working at the time the photograph was taken. No. 3 is empty and shows the method of introducing the air-pipe through the inverted cone of rubber cork in the neck of the bottle, forming the bottom of the agitator. No. 4 shows a settled charge of 25% solids (200 gm. of ore and 600 c.c. of solution). No. 5 is being used as a percolator, the heavy sand forming a filtering medium.

In the section, Fig. 65, the position of the cork, central column, and air-inlet are shown in the positions found best suited for continuous agitation. A is an ordinary brandy bottle, chosen on account of the slope at the neck and of its capacity. B is a $\frac{3}{4}$ -in. gauge glass tube, 8 in. long, the centre of which is directly over the air-inlet. This size of tubing measures about $\frac{7}{16}$ in., inside diameter, and is accordingly rather out of proportion, but was preferred on account of the tendency of the bubbles of air to get outside a smaller column when re-starting agitation after settlement. C is a No. 3 rubber cork, first bored for $\frac{1}{4}$ -in. glass tubing, then cut from the extreme upper edge toward the centre to form a conical bottom below the central column. This cork should be firmly set into the neck. D is $\frac{1}{4}$ -in. glass tubing, with the end closed to about $\frac{1}{64}$ in. by heating without drawing out. The closed end is so inserted that it just enters the bottom of the cone. EE are iron wire supports, bent as shown, to hold the column firmly.

The height of the central column above the air-inlet can be determined by test, using the smallest possible amount of air to agitate, and care should be taken to have the centre of this central column directly above the air-inlet, and also to have it centrally disposed in the bottle. Glass tubing is more suitable for the central column than iron pipe, on account of having a smoother surface which provides for being more easily cleared of packed sand or slime if for any reason agitation be stopped.

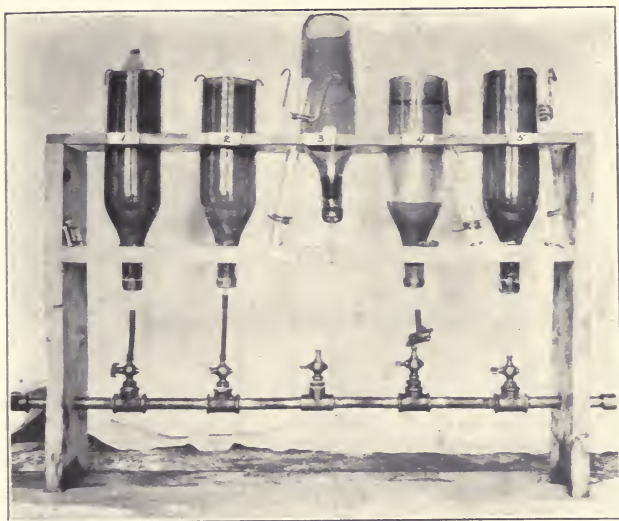

Fig. 64. BATTERY OF 'BROWN' AGITATORS

A mere puff of air is required to maintain agitation in these bottles, but by using well-ground pet-cocks the battery shown was operated continuously with air taken direct from a receiver registering 100 lb. pressure, no reducing valve being necessary. Where compressed air is not to be had, a portable blacksmith forge or electric fan can be arranged to run continuously and give all the air necessary. In starting a test with pulp containing $25\frac{1}{2}$ solids, 600 c.c. of solution is placed in the bottle and the pet-cock opened just enough to start circulation; 200 gm. of the ore is added slowly, so as not to stop agitation; when charged, the upward flow in the column is reduced to the minimum by shutting off the air until the solids at cone are just kept from packing. After agitation is finished, the clear KCy solution is withdrawn, and wash-water added to bring the pulp to the original level. Lift the column and clear it from packed solids by moving gently up and down in the solution. While holding the column a little above the regular position, turn on light air-pressure and gradually lower until agitation starts again.

A series of KCy tests were run on slime all of which passed

200 mesh, as well as on an ore containing 5% of heavy sulphides and giving the following screen analysis:

	%
Between 40 and 80-mesh.....	26.7
On 150-mesh	22.3
Passed 150-mesh	51.0

Perfect agitation was obtained with pulp containing 25% solids.

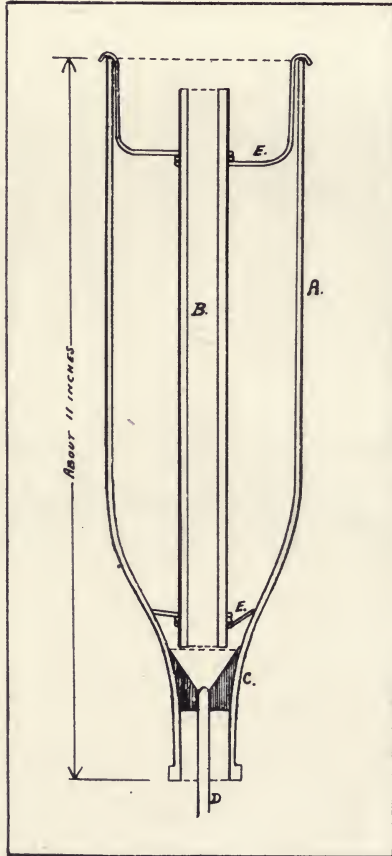

Fig. 65. 'BROWN' TYPE AIR AGITATOR. SECTION THROUGH CENTRE

The agitator will work equally well on slime, sand and slime, heavy sand, or concentrate, and even concentrate in a pulp containing 40% solid matter can be agitated if desired.

After washing, the tailing can be readily removed without addition of excess of water for rinsing. The charge is allowed to settle, and the supernatant liquor is siphoned off until with $\frac{3}{4}$ in. of the top of the settled solids. The bottle is then taken from the stand, the air-inlet pipe is withdrawn from below, leaving the hole

in the cork, through which, with a little shaking and whirling of the pulp, the entire charge may be run out upon a filter. When the ore contains a sufficiently high percentage of coarse material, as in the screen analysis given above, the bottle with the column removed may be used as a percolator. The sand forms a filter above the small opening in the air-inlet, and a few taps upon this will be found sufficient to start the percolation of clear solution after perhaps a little of the finer material has filtered through, which may be released on top.

ALL-SLIMING

By E. M. HAMILTON

(August 21, 1909)

In articles on the cyanidation of silver ores one often reads statements to the effect that the finer the ore is ground the higher the extraction of silver, and that it is now generally admitted that the all-sliming method is the only one for silver ores. Such generalizations as these are, I believe, open to question. Doubtless there are ores in Mexico and elsewhere which need to be slimed in order to give the best commercial results, but in my experience they are in the minority. Even in cases where total sliming will yield the highest extraction it does not therefore follow that that method is commercially the best, and there are instances where even with all-sliming the extraction is no better than that obtained by a separation of sand of a suitable degree of fineness, followed by leaching and agitation respectively.

It is not the function of the metallurgist to transfer without question from the laboratory to the working plant theoretically perfect chemical methods, but rather to combine the qualities of the chemist with those of the man of business, and so to modify theoretical ideals as to obtain the best commercial result. At the present time 'all-sliming' is a common phrase among mining men, and yet, how many of its advocates are putting it into practice? I may here state that for the purposes of this article, I mean by 'slime' everything that will pass a No. 200-mesh laboratory screen. How many so-called all-sliming plants produce a pulp all of which will pass a No. 200-mesh screen? If there are any, it would be interesting to have some figures on the cost of production.

I know of two companies which had mills running on the all-sliming system where the sand coarser than No. 200-mesh amounted to 15 up to 20%. I know of another company running on the all-sliming system where the sand coarser than No. 200 reached 20 to 35%. Such work as this is not all-sliming. Moreover, I maintain that it is bad metallurgical practice, because it is an attempt to treat two different products jointly by a process suitable only to one of them. Even where the method of agitation is such as to admit of sand and slime being cyanided together without detriment to the machinery, it yet seems obvious that a treatment which will suffice for the slime, in point of time and cyanide strength, will be

inadequate for the sandy portion, whereas if treatment be adjusted to the requirements of the sand, then unnecessary time, power, and cyanide is expended on the slime.

Sound practice would seem to demand one of two alternatives: (1) an actual grinding of the entire ore to pass No. 200 mesh, and treatment by agitation; or, (2) a modified scheme of re-grinding to reduce the sand to a size shown to be suitable by careful experiment, and then an elimination from the pulp of all material which will not pass a No. 200-mesh screen, followed by leaching, leaving only material finer than No. 200 for the agitators.

As regards the first alternative, there are undoubtedly cases where the extraction increases almost in proportion to the degree of comminution, and on such ores there is a strong argument in favor of a genuine sliming of the whole, though even here it is not enough to know that a higher extraction will result; the question is, will the additional extraction so obtained more than pay the additional

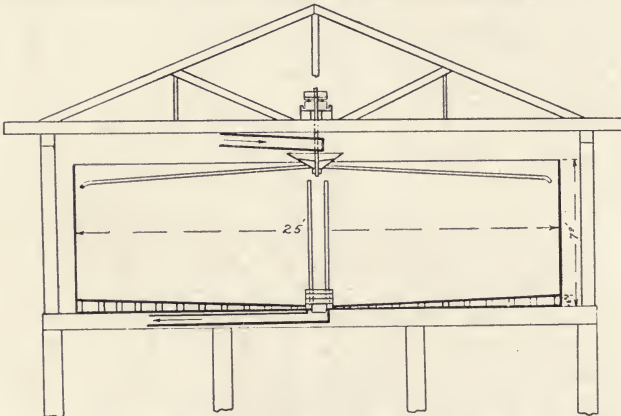

Fig. 66. ARRANGEMENT OF VAT AND DISTRIBUTERS

cost? Those who have had to do with reducing ores to a fine state of subdivision will know that the difficulties and expenses rise as the ore gets finer, and as more of the finished material is eliminated, until it is almost impossible to carry the matter to completion. The first thing to separate is of course the natural slime and fine silica in the ore; next, the most friable portions will yield to disintegration, and so on, until there seems to be left a residuum of the toughest and most refractory material. This latter will circulate round and round the milling system, only a small part being eliminated each time as a finished product. Thus the question arises, does it pay to try to reduce this 20 to 30% to a state of slime, even if experiment shows a higher extraction to be obtainable by so doing? This is a serious question, and can of course only be determined for each individual set of circumstances. If, however, it should be finally decided that it does not pay, why carry on the subsequent cyanidation as if all-sliming were really the method in use, instead of frankly admitting that a varying proportion of the

pulp is not slime, and treating that portion in the way most suitable to it?

Coming now to my second alternative, namely, a modified scheme of re-grinding, followed by the removal of everything that is not slime, and a treatment of the two products by separate methods—the two companies, already referred to as aiming at an all-slime pulp, though with indifferent success, finally decided to abandon the attempt, and while still continuing to produce a fine material in their tube-mills, separated what would not pass No. 200 mesh and erected a leaching plant for treating it. The result was that, with the same crushing units, and with no increase of power or expense, they were able to increase the tonnage 50% or more without decrease in the total extraction. In another case the elimination of the percolable portion of the pulp, besides affording the possibility of increasing the capacity of the mill and cyanide plant, yielded a higher total extraction than when treating the whole as an agitation product, and incidentally showed a saving of about 40 cents per ton in costs for power, filtration, and cyanide.

In what I have said I am not comparing the old method of leaching the sand and agitating the slime with the later one of sliming, or trying to slime, everything. Most silver ores probably give an increased extraction with increasing fineness up to No. 100 mesh, and a few up to No. 200. A later method than either of these is to use a modified re-grinding, aiming in the one case to get as much as possible through the No. 100 screen, and as little as possible finer than this, and in the other to get as much through No. 200 as can be cheaply and conveniently done, but in each case to remove from the pulp everything that will not pass No. 200, and then treat the two products separately by the method best suited to each.

The reason why the leaching treatment has been apparently unsuccessful in some cases where fine-grinding is practised is probably because a good separation of sand from slime has not been obtained. In order successfully to leach a fine sand composed of material ranging from No. 100 to 200 mesh, the following conditions should be obtained: (1) a clean separation, with a minimum of impalpable slime present in the sand; (2) a thorough disintegration of the sand while being transferred from the collecting to the treatment vat; (3) as an almost necessary precedent to (2), a drying out of the collected charge by vacuum before transferring, because the fine sand retains an excessive quantity of moisture, which can never be removed by gravity percolation; (4) it is usually advisable to use the vacuum also during the leaching treatment for purposes of aeration, and for finally drying the charge before dumping, for the same reason as given under (3).

I will here describe an appliance I have used successfully for collecting clean charges of extremely fine sand in the cyanidation of silver ores, and especially where milling is done in solution. It is a circular vat which might presumably be of any desired diameter, though I have never used one larger than 25 ft.; where the

sand is especially fine it is probably better to use a smaller size, say 10 or 12 ft. diam., as this seems to afford better control of the quality of the charge collected; and to use two, or even three, simul-

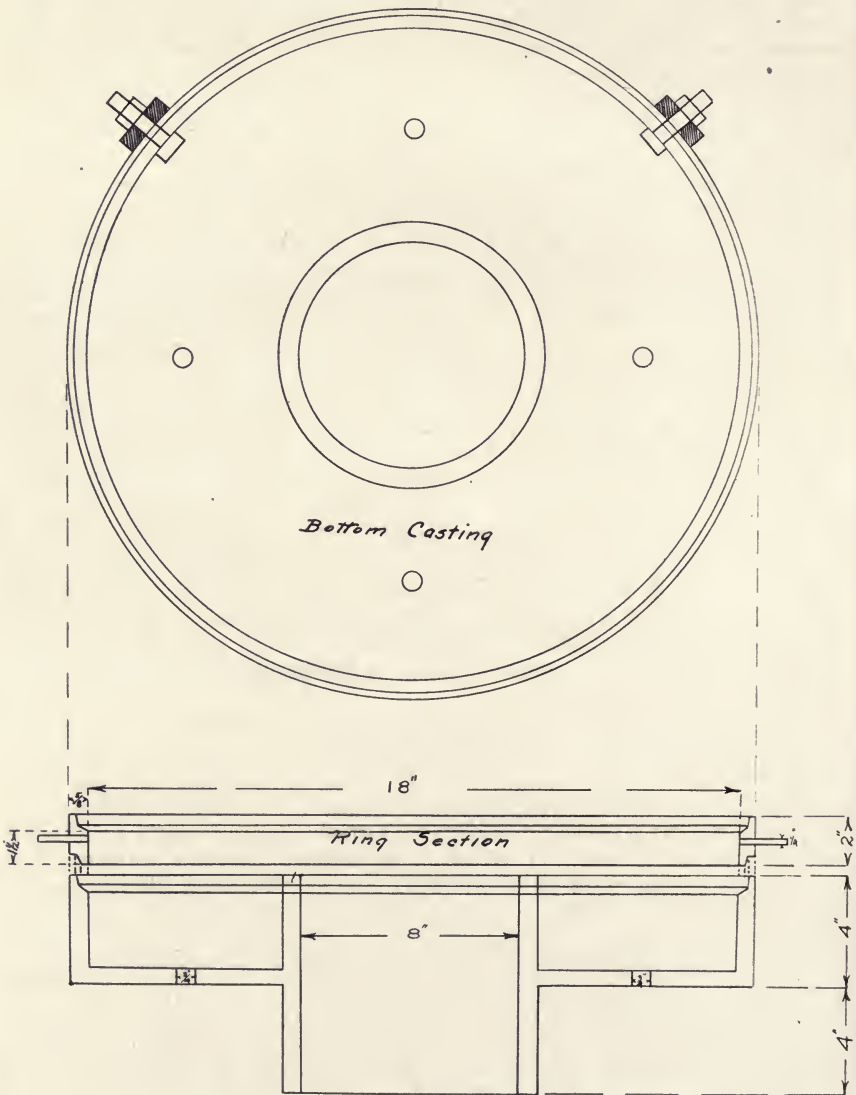

Fig. 67. DETAILED PLAN AND SECTION

taneously, as may be necessary. This vat has a circular central discharge overflow, of about 2 ft. diam. for a 25-ft. vat, and 1 ft. for a 10 or 12-ft. vat. The pulp is fed into an appliance resembling the ordinary Butters & Mein distributor, except that instead of

the pipes being all of different lengths, they are all equal, and extend to within two or three inches of the periphery of the vat; at their extremities they are bent to about a 45° angle, so that they will discharge the pulp against the side of the vat and at the same time afford sufficient power to rotate the distributor. The pulp runs down the side of the vat without any splash, and the sand builds itself up on the bottom in the form of an inverted cone, while the solution and slime flow over the inclined surface and away through the central opening. As the level of the sand rises, the overflow is built up with cast-iron rings 1 or 1½ in. deep, until the vat is full. The distributor is of course suspended from above, and works on a ball-bearing. The rings are lowered into place from the platform which sustains the distributor. They are fitted with small iron pegs, one on each side of every ring, and a semicircular piece of iron.

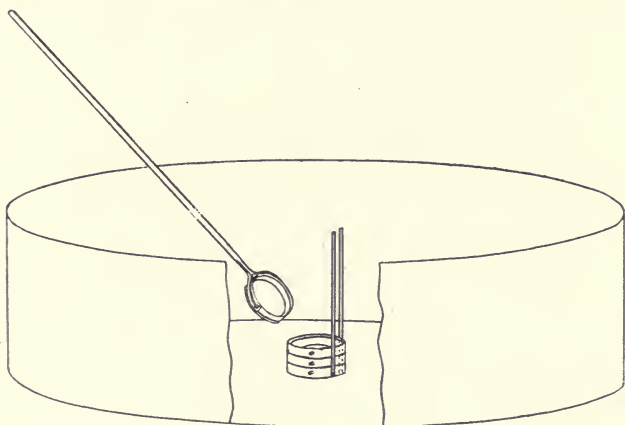

Fig. 68. DEVICE FOR PLACING RINGS

with a hook on each point, and a long handle, is slipped under the pegs; the ring is lowered into place, and the appliance withdrawn. The edges of the ring are offset so as to fit into one another, and thus obviate possible leakage of sand. There are two vertical bars of iron bolted to the casting of the discharge-hole, which act as guides in the placing of the rings. The whole arrangement will be easily seen by a reference to the drawing.

It will be observed that the principle of this collector is entirely different from that of the Butters distributor-vat; in the latter the lengths of the pipes are so designed as to distribute sand over the whole area of the bottom, as far as possible, while the splash is largely depended upon to keep the slime in suspension till it reaches the overflow gates at the periphery of the vat; in the pulp here described the sand settles first at the periphery and the slime rolls over the surface of it till it reaches the outlet. There is never more than a film of solution and slime covering the sand, except for a short distance around the overflow every time a new

ring is lowered. To avoid a layer of slime depositing on the filter-mat before the sand has formed its own angle of inclination toward the centre, the filter-bottom is made slightly conical.

Sand collected in this way does not pack as it does with the ordinary method of distributing; it occupies more space for a given weight; and when well drained falls apart under the shovel, forming a minimum of obnoxious lumps which are so detrimental to good leaching. When the sand to be collected is exceptionally free there is a tendency to agglomerate even with this system, and it is advisable to transfer to the treatment-vats by means of a belt and tailing-stacker to get the charge thoroughly disintegrated and mixed. Incidentally, this appliance forms an excellent slime concentrator, holding back in the sand all but the finest concentrate in the slime, and giving it the advantage of the extra time and cyanide strength, which it would not get in the agitator-vats.

The method of deposition of the sand in this collector is similar in principle to that of the South African 'nigger with a hose' system, with the added advantages of making a cleaner separation, being almost automatic, and having greatly increased precision and regularity. The following are some screen-analyses of material collected in these vats:

Mesh.		No. 1.	No. 2.	No. 3.
		%	%	%
	Over 60	21.6	5.1	...
Under	60 " 80	22.8	15.3	2.9
"	80 " 100	17.2	16.0	11.6
"	100 " 200	19.9	41.2	36.8
"	200 " sand.....	14.8	17.7	43.9
Impalpable slime		3.7	4.7	4.8

In No. 1 the sand was collected in a 25-ft. diam. vat; milling was in cyanide solution; and protective alkalinity was 0.1% in terms of caustic soda. A cone classifier was used to remove part of the slime prior to delivery in the collector. In No. 2 the sand was collected in a 10-ft. diam. vat; milling was in cyanide solution; and protective alkalinity was 0.125%. Here also there was a partial removal of the slime by cones prior to delivery in the collector. In No. 3 the sand was collected in an experimental vat 3 ft. diam; milling was in cyanide solution; and protective alkalinity was 0.15%. The pulp was taken direct from the mill-laundry without previous classification, and no return 'spitz' was used to trap the sand which might have escaped from the collector. The charge of slime separated from this sand only carried 3% of sand coarser than No. 200 mesh.

These three examples are from different mines treating diverse kinds of ore. No. 3 will illustrate the possibilities of this method of separation. The resulting charge of sand, when transferred, percolated by gravity at the rate of $1\frac{1}{2}$ in. per hour through 3 ft. in depth, during a period of 14 days' treatment. I believe that as a separator and collector of exceptionally fine sand in a highly alkaline pulp the device described is unsurpassed by any method at present in use. I have not patented it, because, while the applica-

tion to collection of sand for cyanide leaching is, as far as I know, original with me, yet the principle is that of the old Cornish concave buddle fed by a modified form of Butters & Mein distributor. I have described it at some length, in the hope that it may meet

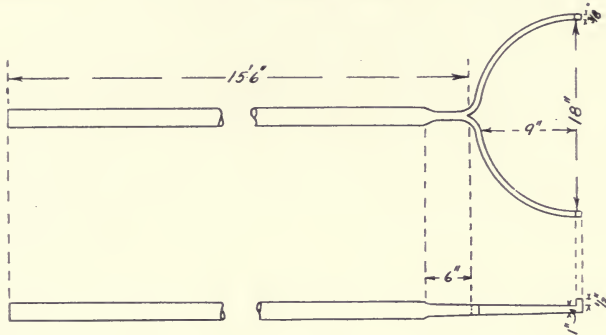

Fig. 69. RING-SHIFTER

the needs of other workers who have been confronted by the necessity of fine-grinding and who yet recognize the difficulty and expense of all-sliming.

(September 18, 1909)

The Editor:

Sir—I wish to express my appreciation of E. M. Hamilton's article on 'All-Sliming', in the *Mining and Scientific Press* of August 21. It would seem impossible to state the conditions obtaining in this important metallurgical method more fairly or more concisely. Few metallurgists have escaped the trials incident to some of the so-called slime-plants. I recently left, without regret, a plant in which they were attempting to agitate with paddles, pump through 4-in. pipes, and eventually cake on a suction-filter, a product of which over 20% was coarser than No. 150 mesh. In another plant of unhappy memory, while only 10 to 15% of the product was coarser than No. 200, the material was of such a nature that if an agitator stopped for 10 minutes, it never started again until dug out. In respect to many such plants, it is certainly easy to agree with Mr. Hamilton that a separation of the two products, with the normal treatment demanded by each, would yield equally good results metallurgically, with less wear and tear, and more peace of mind.

Mr. Hamilton's ideas on the collection of slime-free fine sand are of great interest. At Flores, Guanajuato, some years ago, we noticed that the charge in our sand-collector, fed by a Butters distributor, with the usual arrangement of pipes, naturally rose faster in the middle than at the periphery of the tank. The slime had an apparent tendency to settle and slide toward the sides of the collector, often making a product that gave trouble both on the belt and in the treatment-vat. I had never seen a distributor ar-

ranged to discharge only at the sides of a vat, but it occurred to me that by so doing it might be possible to obtain a peripheral ring of clean sand leaving the slime, some of which would unavoidably settle, to contaminate a more restricted area in the centre. Although we were settling in water, and continued to use our peripheral overflow, this proved to be the case, and we had less trouble with our sand in the future. In the new plant of the Virginia & Mexico Mine & Smelter Corporation, recently started at Hostotipaquillo, Jalisco, I urged a similar arrangement of the distributor, and a central wire overflow. The advantages described by Mr. Hamilton are so manifest, that I shall be surprised if others are not using the same device, supposing, as did Mr. Hamilton and myself, that the idea was original.

In regard to our control weir-overflow, it had been arranged to use the Blaisdell plugs. The manager, Mr. Scobey, suggested that the plug itself might be used as a weir. This was done by simply drilling rows of inch holes around the drum, spaced vertically 4 in. apart. These rows of holes are plugged in succession, as the sand rises, and the device works perfectly. The sand on screening shows as follows: coarser than 100, 20%; between 100 and 200, 45%; finer than 200, 35%. It contains, however, very little coagulable slime, and leaches with exceptional readiness, both in the collector and in the treatment-vat.

A feature of this plant, which is supposed to be original, and which is giving remarkably satisfactory results, is the use of Wilfley tables for separators. By sending the sand-free slime from the head of the table, directly to the slime-plant, and the sand with the small amount of remaining slime to the tube-mills, the use of cones and drag-classifiers is avoided, and apparently just as good a classification and tube-mill feed is obtained. There is positively nothing to clog or break, and the process is 'fool-proof'.

Tables have been used frequently as an aid in classification. I should be extremely interested to know if they have ever been used before in a plant, to the exclusion of other classifying devices.

P. R. WHITMAN.

Jalisco, Mexico, August 30.

[It would be interesting to ascertain when the Wilfley table was first applied as a classifier in conjunction with concentration. That system was being used at the Exposed Treasure mill, Mojave, California, as early as 1902.—EDITOR.]

(September 18, 1909)

The Editor:

Sir—In your issue of August 21 I notice an article on 'All-Sliming', by E. M. Hamilton, in which he criticises the practice of fine grinding as followed at many modern mills which are treating silver sulphide ores. Mr. Hamilton criticises the use of the term 'all-sliming' in mills when after re-grinding a screen-test shows from 15 to 20% of sand which is coarser than No. 200-mesh labora-

tory screen. Technically, Mr. Hamilton is correct. It is not 'all-sliming'. As a matter of practice, however, the term 'all-sliming' is generally used to describe a degree of re-grinding when leaching becomes impracticable, in other words, where the resulting material is treated as slime. In many cases a considerable proportion of the material is still very fine sand, coarser than No. 200-mesh screen, but the proportion of impalpable slime is so great that slime-treatment is advisable. Mr. Hamilton cites the cases of two companies operating mills on the all-sliming system, where the sand coarser than No. 200 mesh amounts to 15 to 20%, and another case where the proportion was even higher. He justly remarks that such work is not sliming. He further remarks that this is bad metallurgical practice. This assertion seems open to dispute. It all depends on the ore. I know of cases where excellent results are being achieved from the treatment of slime containing from 15 to 20% fine sand, coarser than No. 200 mesh.

Take for example a silicious ore in which the metal is present in the form of rich silver sulphides, often minutely disseminated through the quartz. Such is a typical Tonopah ore. Here fine-grinding is necessary in order to liberate the extremely fine particles of mineral from the gangue and, incidentally, to allow the cyanide solution to come into intimate contact with the particles of ore. Experiments show conclusively that extremely fine grinding is essential if these results are to be attained. The economical limit of reduction is fixed by two things: first, the difficulty of concentrating the very finely divided particles of mineral, and, second, the cost of re-grinding.

It has been conclusively proved that it is impossible to cyanide such an ore successfully until the greater part of the sulphide minerals have been eliminated. Further, that it is impracticable to reduce all the material issuing from tube-mills to a certain degree of fineness at one operation. As stated by Mr. Hamilton, the cost of re-grinding the 15 to 20% remaining would be excessive.

Although it is impracticable to re-grind this small proportion of sand until it is reduced to a slime, it by no means follows that it would pay to classify and treat it separately. The additional cost of installation and operation of a small leaching plant would more than offset any possible increase in extraction. But there are other important reasons for not separating the small proportion of fine sand. Of these the most important is the effect during filtering. In filters of the submerged vacuum type, or even of the self-containing type, the permeability of the cake is increased enormously by a small quantity of fine sand, provided that the pulp is in a state of suspension while the slime-cake is being formed. During the experimental stage, before the Goldfield Consolidated mill was designed, a series of exhaustive tests were made along the lines advocated by Mr. Hamilton, namely, moderate re-grinding and subsequent segregation into sand and clean slime. This plan of treatment was only abandoned after it was found that the clean slime

formed an absolutely impervious cake on the filter, from which it was impossible to displace the gold-bearing solution.

EDGAR A. COLLINS.

Tonopah, Nevada, September 3.

(December 4, 1909)

Sir—I have read with very great interest E. M. Hamilton's article on 'All-Sliming', which appeared in your issue of August 21. In it Mr. Hamilton describes a method devised by him for the separation and collection of fine sand for cyanide leaching. A practically identical method of classification has been in use at this mine for the past twelve months. It was thought out by George L. Carlisle, a local mine operator, and has given entire satisfaction, producing the cleanest product it has been my fortune to handle; this with a mill-product averaging over 60% slime.

After passing through a cone classifier, which removes the lighter slime, the battery product is fed to a distributor possessing arms of such length that the pulp is directed against the sides of the vat. All the arms are of equal length and have nozzles bent at an angle of 45°, exactly as described by Mr. Hamilton. The pulp running down the sides of the vat builds itself gradually upward with a smooth level floor sloping gently toward the central discharge. This discharge consists of a vertical wooden tube of square cross-section, 3 in. diam. On two sides are bored 2-in. plug-holes at 4-in. centres. These are staggered in such a manner that there is a hole for every 2 inches in height of the collecting tank. The slime running down the sloping surface of the collected sand, is discharged through the holes. As the tank fills, the sand gradually approaches the centre, and when within 18 in. or thereabout of the plug-hole, the latter is closed with a wooden plug, and the slime-discharge takes place through the aperture next above.

It will be seen that this method only differs from that of Mr. Hamilton in the form of the central discharge. His method, that of a tube built up in sectional rings as the tank fills, has the merit of obviating descent into the tank. At this mine a ladder is left in the collecting-vat as it fills, standing on the rungs of which the workman puts in the plugs as occasion requires. The method of filling with a Butters distributor, meanwhile drawing off the slime through plug-holes, is not new, having been used in at least one Californian plant. There, I believe, the holes were in the periphery of the vat. The use, however, of a distributor having arms of equal length so arranged as to allow the pulp to impinge on the wall of the vat, coupled with a 'built-up' central discharge, seems to me to be original with Mr. Hamilton and Mr. Carlisle, and a happy instance of two minds in different parts of the world hitting upon the same ingenious and simple idea.

HUXLEY ST. J. BROOKS.

La Libertad, Nicaragua, October 13.

BOSTON-SUNSHINE MILL

By G. W. Wood

(August 28, 1909)

In July, 1908, I was employed by the Boston-Sunshine Gold Mining Co. to design plans for remodeling the old Sunshine mill, at Sunshine, Utah, and I afterward supervised the construction and have operated the mill up to date. The process as used and the method of treating the ore, were substantially the same as those followed in a number of mills in the Black Hills of South Dakota, which are operated by or under the supervision of J. V. N. Dorr, of Denver, Colorado, milling ores amenable to the same treatment, although the Black Hills ores are chiefly silicious, while at Sunshine the ore consists largely of 'tale'; in both of these, however, the treatment is practically identical. The history of the Sunshine mill, with its record of four unsuccessful attempts to treat the ore, is sufficiently well known. These failures were probably due to improperly separating the slime from the sand, and to consequent failure to properly leach the latter; also there was failure to get good extraction from the slime at a reasonable cost.

Prior to re-construction, the mill-building and such of the old machinery as was subsequently used were in good condition, considering that the property had been idle for several years. In reconstructing this mill, the boiler and engine rooms, crushing-room, hoist-room, and the mine and crushed-ore bins were allowed to remain intact, with the exception of a few minor changes and repairs; the lower end of the mill only being reconstructed and adapted to the new process. Hoisting, crushing, and elevating are done by steam-power; from that point electric power is used.

In the mill the ore as it enters is tripped from a skip into the mine ore-bin; from here it drops by gravity over grizzlies, the fine ore going directly to the elevator-boot, the oversize going to two gyratory crushers. From the crushers the ore goes through a revolving screen, the fine going directly to the elevator-boot, the oversize to rolls and thence to the elevator-boot. All of the ore is elevated by an endless belt bucket-elevator and dumped into the crushed-ore bin. From this the ore is fed to an endless-belt conveyor by which it is carried up into a mixer-classifier of a type designed by George H. Dern, general manager for the Consolidated Mercur Gold Mines Co. The slime at the overflow end of this mixer-classifier goes by gravity to a Dorr classifier, the sand from the sand end going to a second mixer-classifier. The sand from this goes direct to the sand-tanks for leaching, the slime to the Dorr classifier, together with the slime from the first mixer-classifier for further classification. From the Dorr classifier the sand goes direct to the sand-tanks for leaching, mixed with sand from the second mixer-classifier, and thence to the sand-tailing dump. The slime goes to a 12 by 35-ft. settling-tank, in which is operated a Dorr continuous slime-thickener. The thickened slime is drawn out at the bottom of this tank through a 4-in. pipe, as desired, by opening and closing a gate-

valve operated from the Moore-process floor, and is forced by difference of head to the charging-vat of the Moore process.

The Moore process, as installed here, consists of three rectangular vats, with hopper-bottoms, and two sets of filter-leaves built up in two moveable frames, connected to vacuum-pumps; also an additional vat for cleaning the filter-leaves. The operation of the Moore process is as follows: A clean frame is first immersed in the charging-vat. The suction from the pumps then draws the mill-solution from the thickened slime through the leaves. This comes out as 'gold-solution', and at the same time the pulp builds up a cake on the leaves, requiring from 30 to 45 minutes to make a cake $\frac{7}{8}$ in. thick, dependent upon the thickness of the pulp. After having picked up about a $\frac{7}{8}$ -in. cake, the frame is lifted by means of a hydraulic crane, and is deposited in the barren-solution vat, where clear barren solution is drawn through for further extraction of the metal in the cake already picked up. After a given length of time, dependent upon the assays, the frame is moved from the barren-solution vat to the wash-water vat. In this, wash-water is drawn through the frame for a sufficient length of time to extract the remaining metal which may be recovered advantageously, and to displace the cyanide solution in the filter-leaves and cake. Water and air are then forced through the leaves in inverse order, the cake drops off, and falling to the bottom of the vat is forced out as slime-tailing, by the head of water above it. This is done by opening a sluice-gate operated from the Moore-process floor. Both frames are operated continuously at the same time, but, of course, each frame being at a different stage of the cycle. The constant-level tanks, operated by means of float-valves, ensure a uniform rate of flow throughout when the valves are opened at given points.

A series of gauge-boards, assembled at the Moore-process floor, with wires connected to floats in the mill-solution storage, mill-solution sump, barren-solution storage, barren-solution sump, and gold-tanks, indicate at all times, at this point, the tons of solution which these tanks respectively contain. An electric gong, also connected with the same, rings when any of the tanks are filled within a given distance from the top. This ensures prompt attention without close watching, and prevents the tanks from overflowing. Sampling is done in this mill automatically. At the elevator head is an ore-sampler making uniform grabs, and operated at regular intervals by means of dumping-buckets, placed over the mill-solution sump, with which it is connected. A sampler over the barren-solution sump, operated by the solution flowing through it, continuously measures the amount of barren solution going into the barren-solution sump, and at the same time takes uniform samples at regular intervals. This sampler also operates another, taking uniform samples of gold-solution flowing into the gold-tanks, simultaneously with the barren-solution sample. The tons of solution registered by the first sampler multiplied by the value of the gold-solution sample, less the value remaining in the barren-solution sample, is the value precipitated. For a period of five months this sampler,

in one of the Black Hills mills, has checked up within 0.11 of 1% with the bullion.

In the general arrangement this mill, in comparison with some others, may seem crowded, but in this instance it is a distinct advantage. Everything in connection with leaching is in sight, or is at hand, and can be reached from the Moore-process floor at a moment's notice in the event of anything going wrong. A man standing on that floor, on the side toward the sand-tanks, can see the pumps, shafting, and motor in the pump-room below, and the Moore-process pumps and other apparatus on the floor he is on. Above him are in sight the classifiers, launders, conveyor, motor, and shafting; the gauge-boards at his side keep him posted as to the quantity of solution in the various tanks and sumps. A few steps up and he can look directly into the sand and settling tanks.

The ore, by differences, from actual milling, has consisted of 50.85% sand and 49.15 slime; sand-tailing has averaged about 60c., slime-tailing 20c., the general tailing for the month of May having been 39.3c. The heads during May averaged \$3.48. Two hundred tons of ore have been treated in this mill in 24 hours without appreciable inconvenience. The extraction for the month of May, the second month's run, was 88.7%, at a cost of milling of 84.9c. per ton of ore.

SIMMER DEEP AND JUPITER REDUCTION WORKS

By J. E. THOMAS

(September 18, 1909)

The joint reduction works of the Simmer Deep, Ltd., and Jupiter G. M. Co., Ltd., were erected and put into operation on September 1, 1908, to treat the ore from these two companies' mines, both of which are under the control of the Consolidated Gold Fields of South Africa, Ltd. Separate mill-bins of 5460 and 2525 tons capacity are provided, the ore from each mine being treated separately until it leaves the mill-tables, when it mixes on entering the tube-mills and thence the cyanide plant. The recovery obtained by tube-milling and cyaniding is apportioned to each company on the basis of the tonnage and value of the tailing leaving each company's mill-tables.

Briefly the processes are as follows: breaking the ore to $1\frac{3}{4}$ -in. cube at each of the company's sorting and crushing stations; transport by means of hopper-bottomed cars of 35 and 45 tons capacity, drawn by a 48-ton locomotive on a 42-in. gauge track; stamp-milling with heavy gravity stamps of the Californian type, and amalgamation over stationary copper-plates; tube-milling and amalgamation over copper shaking-tables; classification of slime and sand by means of cone classifiers; treatment of sand by means of rotary filter-tables and wet-filling of tanks with cyanide solution, with subsequent transfer and percolation with cyanide solution; treatment of slime by the decantation process; precipitation of gold

from solutions by zinc shavings, using zinc-lead couple; acid-treatment of gold-slime; calcining, and smelting.

The mill consists of 300 heads of stamps arranged five in each mortar, in blocks of 10, each 10 stamps being driven by a 50-hp., 3-phase, electric motor. The current is generated and supplied by the Victoria Falls (Transvaal) Power Co., from their station at Brakpan, about twenty miles distant. The framing of the mill-buildings and bins is entirely of steel girders, the bins themselves being of timber 6 in. thick on the sides and 6 in. at the ends. The mortars are of the straight-backed type and are especially heavy, having a bottom 15 in. thick. Each weighs 11,872 lb. They are placed on concrete foundations, separate foundations for each 10 stamps, 17 by 10 ft. at the base and 15 by 4½ ft. at the top and 10 ft. high. Each block contains about 102 tons of concrete, and has a sheet of best rubber ¼ in. thick between the bottom of the mortar and the concrete. The anchor bolts are six in number, 1¾ in. diam. by 7¾ ft. long, so placed as to be readily accessible for tightening and replacing. The mortars are 6 ft. high, taking a 59-in. screen-frame. The height of the screen-opening is 24 in. Each box has five 1-in. openings for the admission of water from the back-water service. These are so arranged as to give a jet of water playing on each die at an angle of 45° to the surface of the die. Manganese-steel liners are fitted in each box to take the wear due to attrition. The stamps weigh 1670 lb. each, when new, made up as follows: stem, 723 lb.; tappet, with gibs and keys, 252 lb.; head, 410 lb.; shoe, 285 lb.; stems are 4 in. diam., placed at 10¾-in. centres. The order of the drop is 1, 3, 5, 2, 4. The set height is 8½ in., height of discharge 4 in., and number of drops 100 per minute. The estimated duty per stamp is 8.7 tons per 24 hours, but this has already been exceeded using a 500-mesh screen, 0.033 in. aperture.

The king-posts are of timber of the 'built-up' type, to prevent twisting, and are seated in cast-iron shoes resting on the rubber on the concrete foundations. This also obviates an unnecessary amount of timber above the cam-shaft bearings. The cam-shafts are 16 ft. 3 in. long and 7 in. diam., and the majority are of the 'riffléd Blanton' type. Other methods of fastening the cams on the shafts are also being used. The feeder-chutes are provided with sliding doors on the bins, while the feeders themselves are driven by means of ¾-in. manila ropes from rocker-bars placed at the back of the king-posts above the cam-platforms. The front of the cam-platform is supported directly from the concrete foundations, independently of the king-posts. The reduction of the vibration on the platform, due to this method, is noticeable. The mill clean-up room is spacious and contains 3 revolving drums for cleaning amalgam; 3 amalgam barrels, 3 bateas, and a clean-up table sump. Besides these, a small tube-mill 6 ft. 6 in. by 5 ft., with a shaking table, two 10 by 10 ft. conical bottom vats, and a precipitation-box, for the treatment of black sand, tailing, and the like material by tube-milling and cyaniding, are provided. Two retorts and three Cornish fires are also in

this room so that the amalgam is retorted and the bullion run into bars before leaving the mill-buildings.

The carpenters' and mill-fitters' shops are under the same roof as the clean-up room, but are separated therefrom by a fireproof brick wall. The only entrance to the clean-up room is from the mill, past the mill-foreman's office.

The arrangement of the batteries back to back, 150 stamps on each side, with the bins between, admits of extensions being easily made at the southern end of the mill. The motors drive down to small counter-shafts, one for each 10 stamps, which are placed below the feeder and motor floor, by means of 11-in. belts. Thence the drive goes direct by means of a 21-in. belt to the 7-ft. cam-shaft pulleys. The counter-shafts are moved by means of bevel-gear wheels,

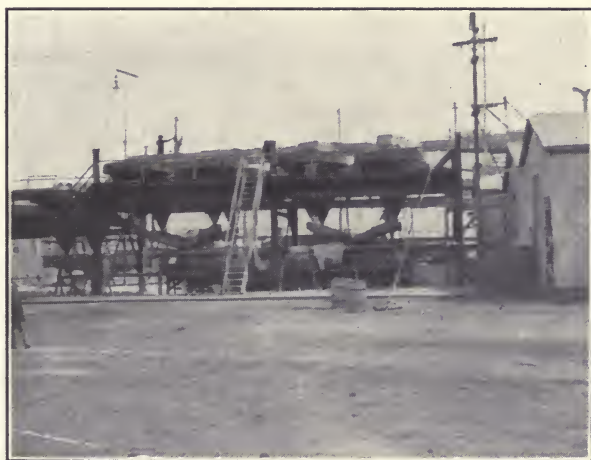

Fig. 70. SAND PLANT AND FILTER TABLES

so as to take up the stretch in the motor and cam-shaft pulley belts. On leaving the mill-tables the tailing passes through mercury traps and launders to the tailing-pits, of which there are two, one for the 200 Simmer Deep and one for the 100 Jupiter stamps. From there the pulp is elevated by means of 8-in. centrifugal pumps, three to one pit, and two to the other, only one in each pit being normally run at a time, to the cone-shaped tube-mill classifiers. Of these there are two to each of the four tube-mills, 45 in. diam. at the overflow and 7 ft. deep, with a $\frac{7}{8}$ -in. nozzle at the underflow. These, in turn, deliver into a de-watering cone, 36 in. diam. and 5 ft. deep for each tube-mill, with a $1\frac{1}{4}$ -in. nozzle at the underflow. The overflow from these de-watering cones joins the stream at the tube-mill outlets so as to make the re-ground pulp fluid enough to pass over the shaking-tables, of which there are five, 12 by 4 ft. 7 in. to each tube-mill, and which run at 200 shakes per minute. The tube-mills are of the Krupp type, and are 22 by 5 ft. 8 in. inside in the shell, and are lined with $5\frac{1}{2}$ -in. local flint-sets. Each mill is

driven by a separate 125-hp., electric, 3-phase motor, and running at 30 r.p.m., takes about 104 hp. The pulp passes from the underflow of the de-watering cones through Pryce's feeders, through which are also fed the pebbles to maintain the pebble-load in each mill about 6 in. above the centre. These pebbles are pieces of ore about 4 in. diam. picked off the belts of the sorting stations and delivered to a special bin, from which they are trammed to the tube-mills in small cars of 10 cu. ft. capacity. The average working-load of pebbles in each mill is about 10 tons, and about 5 tons per mill per day are fed in to maintain this. The tailing from the shaking-tables joins the main pulp in the tailing-pits and is re-elevated to the classifiers, any particles that still require re-grinding passing down again through the classifiers, the remainder overflowing with the fine product in the mill-tailing to the cyanide works. A small locomotive-type boiler is installed in a separate shed, outside the mill buildings, to provide steam for steaming plates.

Hand samples of the pulp entering the cyanide works are taken every hour at the overflow launders of the tube-mill classifiers, and reserved for grading and assaying. The pulp is then run to 12 cone classifiers, placed in parallel, 6 ft. diam. at the overflow, and 6 ft. 6 in. deep with a 2½-in. nozzle and internal regulating plug at the underflow. The pulp overflowing from these classifiers flows directly to the slime-plant, passing over 10 return-sand spitzkasten on the way. The underflow, containing about 4% slime, is pumped by means of a 6-in. centrifugal pump to the cones of the continuous sand-filter plant, with the addition of a little clear water. This plant consists of two rotary filter-tables 20 ft. diam., with a 2 ft. 6 in. filter-bed, equal to 137 sq. ft. each, revolving at a speed of one revolution every three minutes. The filter is composed of strong screen cloth, supported on wooden slats on edge, 4½ in. centres, over which is laid cocoa-matting, well caulked at the inner and outer edges. On this again are placed strips of unbleached calico to prevent any slime, which may penetrate through the working-bed of sand, 1½ in. thick, choking the cocoa-matting. Over each of these tables four cones, 8 ft. diam. at the overflow and 8 ft. deep, are placed. The pulp overflowing after passing over two return-sand cones of the same dimensions, joins the main stream to the slime-plant. The underflow, containing about 30% moisture and 1% slime, runs down launders of 30% grade on to the filter-beds. The under-side of this bed is connected to a vacuum-pump, through a receiver, the moisture collecting in which is removed by means of a 3-throw plunger-pump, and returned to the main tailing-stream. A vacuum of from 5 to 10 in. is found most effective; if higher, the sand of the filter has become choked with slime and requires renewing. This is usually done once every 24 hr., the operation taking about 50 min. for both tables. Only three cones are normally in use for each table, the fourth being only used when the other table is out of action for renewal of the filter-bed or other parts. One table, working with four cones, is capable of dealing with about 60 tons of sand per hour for four or five hours. Both the primary

and secondary cones are provided with diaphragms placed about 2 ft. above the underflow. The sand, containing about 15% moisture, is removed from the table by means of a plough, and falls into a launder in which a 0.03% KCy solution is running. Thence it is elevated by means of a centrifugal pump to the collecting-vats. Of these there are eight in use, two being utilized for storage and the other six for collectors. These vats are 50 ft. diam. and 8 ft. 3 in. above the filter-mat, and are fitted with Butters & Mein distributors, and annular overflow launders. The solution overflowing the vat that is being filled runs into one or other of the storage-vats from which it gravitates back to the launder at the rotary filter-



Fig. 71. CONTINUOUS SAND COLLECTOR

tables, and is again pumped up with fresh sand from the tables. Means are provided for removing any accumulation of slime in the storage to the slime-plant for treatment. Each collector-vat averages 738 tons of dry sand. After being filled and leached dry the charge is removed through 10 bottom-discharge doors on the three shuttle-belts which in turn discharge onto the main belt. These shuttle-belts are mounted on rails, and so arranged that they can be readily shifted from one vat to another by means of a transferring gear. Altogether there are six shuttle-belts 42 ft. centres and 32 in. wide for discharging the collecting-vats, so that while three are being used the other three can be placed in position under the next vat to be discharged and so save time. The time required to empty a collecting-vat of sand is $3\frac{1}{2}$ hr., the shoveling being done by 24 natives. From the main belts, of which there are two, one set 275 ft. centres and 28 in. wide, and the other 453 ft. centres and 28 in. wide, driven by two separate 20 and 50-hp. motors, the sand passes to another shuttle-belt, 260 ft. centres and 32 in. wide, running on staging between the treatment-vats. 50 by 10 ft., arranged in two rows of five. From the shuttle-belt it is then discharged

to Blaisdell distributors, two in number, each running on rails over each row of treatment-tanks. The sand is discharged from these after completion of treatment by means of 20 cu. ft. trucks fitted with side-jockeys and wire-rope mechanical-haulage to the two residue dumps.

The slime-plant is of the decantation type, and consists of four collector-vats 70 by 12 ft. deep at the sides with a cone 5 ft. 6 in. deep, equal to a flat-bottom vat 70 by 13 ft. 10 in. deep. There are also four first-wash vats, one intermediate transfer-vat and four second-wash vats, of the same dimensions. Each vat is capable of holding 400 tons of dry slime and 1400 tons of solution, and is fitted with a centre-valve which also contains a 2½-in. nozzle for solution to facilitate transferring and discharging of the slime-pulp.

This is accomplished by means of two 12-in. centrifugal pumps, with 16-in. suction and discharge pipes. Only one of these pumps is used on any one vat at a time, but they are so arranged that either pump can be used on any vat for one operation, while the other is being used for another operation on any other vat. The first-wash solutions are decanted by gravitation to a small vat 20 by 6 ft., fitted with an annular overflow-launders. This allows of the settlement of calcium carbonate from the solution, which would otherwise choke up the cloths of the clarifying presses. The solution is pumped from this vat by a 6-in. centrifugal pump through three clarifying presses to a steady-head tank; thence to the extractor-boxes. The second-wash solution can also be run through this system to the extractor-boxes, if desired, but is normally pumped through a 6-in. centrifugal pump to the first-treatment vats or intermediate second-wash storage as required. This is of the same dimensions as the precipitated slime-solution intermediate-storage, namely, 70 by 12 ft., and is placed alongside it. The solutions from these storages is pumped through either of two 3-in. centrifugal pumps with 12-in. suction and discharge pipes, to any of the nine treatment-vats. A separate 6-in. centrifugal pump is provided to deal with the water decanted from the slime collector-vats. This water joins the stream from the annular overflow launders of these vats, and runs to the return-water vats, one 70 ft. by 16 in., fitted with an annular overflow-launders delivering into a second also 70 ft. diam. and 12 deep. This minimizes the risk of slime remaining in suspension in the water returned to the mill. From the return-water tanks the water is pumped by three 8-in. centrifugal pumps to the mill-service tanks. Of these there are two, one 40 by 14 ft., and the other 40 by 12, mounted on staging 22 ft. high and arranged in the same manner as the return-water vats. Outside the extractor-house is a shed containing one vacuum and one 3-throw plunger-pump, used to assist leaching, and to aerate sand-charges while under treatment in either the collecting or treatment-vats. The extractor contains 20 steel zinc-boxes 30 ft. long and 5 ft. wide, each divided into two boxes of six compartments.

Twelve boxes are placed on the north side for dealing with solutions from the treatment of the sand. Of these, two are used for

strong solution (over 0.05% KCy), the remainder being for weak solutions: One of the latter can be used for either weak or strong solutions, as desired. The other eight boxes are placed along the west side of the extractor-house near the clarifying-presses and deal with solutions from the slime-plant only. Each of the clarifying-presses contains 48 hollow frames 32 by 32 in., and gives 600 sq. ft. of filtering area, and is placed in a shed just outside the west side of the extractor-house.

The clean-up room for acid-treatment of the gold-bearing zinc-shaving from the extractor-boxes is in the middle of the extractor-house, the zinc-cutting lathes occupying the east side and the refinery the south side of the building. The extractor-boxes, clean-up room, and refinery are fenced in so that no unauthorized person may enter. The acid-treatment plant consists of three dissolving-vats 10 by 6 ft. and three washing-vats 10 by 10. These are all provided with mechanical stirring-gear. Bisulphate of sodium is used for dissolving the zinc from the boxes. This is dissolved in water in a lead-lined vat 10 by 10 ft., so as to give a solution containing about 18% free sulphuric acid. This is diluted with its own bulk of water before being used in the zinc-dissolving vats. The bisulphate dissolving-vat is placed at the south end of the shed containing the clarifying presses, with a small boiler of the locomotive type between. This latter is used for heating the bisulphate solution when necessary, and for obtaining steam and hot water for the various small jobs, such as washing the cloths of the clarifying presses, washing the acid-treated gold-slime in the filter-presses, and so on. These filter-presses, of which there are three, 24 by 24 in., stand in the same room as the acid-treatment vats. The washes decanted from the acid-washing vats flow into two wooden vats 25 by 12 ft. where they are allowed to stand for several days, and, if necessary, treated with zinc-dust before being run to waste. The solution from the strong extractor-boxes runs into two steel storages 40 by 12 ft., that from the weak boxes into two 50 by 12, and the solution from the slime-boxes into one storage 50 by 12. Another storage of the same dimensions is also provided for surplus solution, that is, last drains from the sand-treatment vats, low in gold, waiting to be transferred to the slime-plant for the sake of its free KCy.

The refinery, which occupies the south side of the extractor-house, contains, besides a fluxing-room, one reverberatory pot-furnace capable of holding 26 No. 100 pots; one calcining furnace; one pan furnace for smelting slag, sweepings, and the like; one cupel furnace, and three Cornish fires for melting and casting the bullion into bars. As at the mill, no gold-bearing material leaves the extractor-house except in the form of bars of bullion ready for depositing in the bank. All the furnaces in the refinery lead into one main flue 3 by 2 ft. 6 in. ending in an iron stack 90 ft. high by 5 ft. 6 in. lined for 40 ft. of its height with fire-brick.

RESEARCHES UPON CRIPPLE CREEK TELLURIDE ORES

(September 25, 1909)

*Among the gold-producing districts of the world, Cripple Creek district, of Colorado, stands as one of the foremost. This volcanic area, three miles long by five miles wide, embodies a network of gold-carrying veins, running in all directions, intersecting each other and comprising a series of ore-shoots the magnitude of which is inconceivable. Along with the development and mining of the higher grades of ore, material has simultaneously been developed which, although of sufficient value to term ore in some other parts of the world, on account of its refractory nature is left standing in the mine stope or thrown upon the waste-dump. The refractory nature of these ores is due largely to the occurrence of the gold in combination with tellurium, forming a compound $(AuAg)Te_2$, which is represented by the minerals calaverite, or sylvanite, and also to the association or encasement of these gold tellurides in crystal growths of the characteristic mineral pyrite.

The history of the metallurgical treatment of these ores is conspicuous for the number of metallurgical failures which have taken place, due largely to the difference in the physical properties existing between gold telluride and native gold, and partly to the insolubility of the tellurides in cyanide solution. Stamp-milling followed by amalgamation was first tried; concentration failed, while at the smelting works these ores were not desirable owing to their high silicious character. Only after roasting to free the gold of its volatile associate have the ores been susceptible to lixiviation processes. Consequently, roasting, followed by barrel chlorination and concentration has become the popular treatment. This method works well so far as extraction is concerned, but as the amount of low-grade ore standing in the stopes and upon the dumps becomes larger year after year, it becomes apparent that a cheaper method of treatment must be found. With this end in view the Portland Gold Mining Co. experimented extensively.

Fine grinding in cyanide solution followed by agitation and filter-pressing was first tried, but difficulty in dealing with the stubborn sylvanite was experienced, so that efforts were naturally directed toward finding a solvent for tellurium. It was found that the tellurium yielded to some extent under the action of oxidizing agents, and after trying various acid mixtures it was resolved to find an alkaline solvent. The most successful were the alkaline per-sulphates, alkaline hypo-iodites, and cyanogen iodide. The chemical behavior of the alkaline per-sulphates is little known to metallurgists. They are not only solvents for tellurium, but their action when used in connection with cyanide solution is extremely interesting. They act as slow oxidizers, or depolarizers, thereby greatly increasing the dissolving power of cyanide solution, and

*By Portland Met. Soc., Edited by Thos. B. Crowe. *Jour. Chem. Met. & Min. Soc.*, South Africa. See *Mining and Scientific Press*, November 20 and December 25, 1909, for discussion as to rights to the invention.

when used in small proportions, 1 to 10 lb. per ton of solution, they do not destroy the cyanide to any great extent. A good deal of theorizing regarding the chemical action of these substances, especially when used in connection with cyanide solutions, has been indulged in. When in solution alone, they act as strong oxidizing agents, as follows:

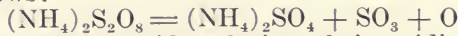

But when mixed with cyanide solution, their oxidizing influence is greatly retarded. In view of this fact, together with results obtained in small tests, it is evident that the per-sulphates, if produced at a low cost, could be generally used in cyaniding as oxidizing agents. They are quite stable compounds, and when mixed with working cyanide solution would oxidize reducing agents, thus greatly aiding dissolving efficiency and precipitation.

A recent article, 'Cyaniding of Silver Ore in Mexico', by W. A. Caldecott, brings to mind a possible field for these substances as a means of dealing with the reducing agents, which this article states are a great source of trouble. Ammonium per-sulphate is a good solvent for silver, but to what extent this property can be applied in ore-treatment has not been determined.

The following few small tests have been made on the solution from the tailing mill in the endeavor to find the effect of per-sulphates upon cyanide solution when used as oxidizing agents.

Three assay tons of blanket concentrates which assayed 108 oz. gold per ton were put in each of six bottles: in each bottle was poured 262 c.c. of regular 1-lb. tailing-mill solution; this made a three to one pulp, and 10 lb. of lime per ton of ore was added. To the first three bottles respectively, was added 0.1, 0.25, and 0.5 lb. of ammonium per-sulphate per ton of ore; the last three bottles being left as straight cyanide treatment. All the bottles were well shaken and stood over night.

No.	Cyanide consumed per ton of ore, lb.	Ammonium per-sulphate added per ton of ore, lb.	Solution assay value, oz.
1.....	0.55	0.10	4.13
2.....	0.55	0.25	4.35
3.....	0.55	0.50	4.46
4.....	0.60	None.	3.54
5.....	0.55	None.	3.82
6.....	0.55	None.	3.72

From these experiments is readily seen the effect of the increased dissolving efficiency obtained when an oxidizing agent is used, the consumption of cyanide being practically the same as the straight cyanide treatment. Taking the average solution assay 4.313 oz. of the three bottles to which per-sulphate had been added, and comparing the average solution-assay 3.693 oz. of the three bottles where no per-sulphate was added, and multiplying each average by three (as three to one pulps were used), there is obtained a difference of 1.86 oz. extracted by the addition of small quantities of per-sulphate. The low extraction obtained in either case is sur-

prising, but it is a good example of the refractory nature of the gold. This material had passed through a roasting furnace, through chlorination barrels, over the Wilfley tables, then ground to 60-mesh in 1-lb. cyanide solution, then caught on blankets, and was merely used in these experiments on account of its value to make a decided case.

As stated before, alkaline per-sulphates are solvents for tellurium, and when mixed with cyanide solution completely dissolve the telluride of gold. Several bottle tests were made on ore, using a solution of alkaline per-sulphate as a preliminary treatment followed by cyanide solution, the object being to first dissolve the tellurium, leaving the gold in a condition susceptible to cyanide solutions, but with poor results on account of reasons explained later, except where extreme amounts of per-sulphates were used. There was also tried a treatment using the alkaline per-sulphate and the cyanide together in the same solution, dissolution of the tellurium by the per-sulphate and the dissolution of the gold by the cyanide going on simultaneously, but with uneconomical results due to reasons explained later.

Alkaline per-sulphates, like some other oxidizing agents, liberate iodine from potassium iodide in an alkaline solution, the liberated iodine combining with the alkali present to form alkaline hypo-iodites, which compounds dissolve tellurium; it was therefore concluded that the addition of potassium iodide to a solution of per-sulphate plus cyanide would form this tellurium dissolving compound, while the cyanide present would take care of the gold, the two working simultaneously.

For a long time the experimenters were led astray. They had found that an excess of alkali in a solution of potassium cyanide plus potassium iodide, plus alkaline per-sulphate, greatly increased the solubility of gold leaf; test after test with good excess of alkali was tried, believing that the solution that had the greatest dissolving efficiency upon gold would have the greatest efficiency upon the telluride of gold, and working on the theory that the liberated iodine formed hypo-iodite, which dissolved the tellurium, the cyanide present dissolving the gold, it could not be seen wherein an excess of alkali would be injurious; but failure to obtain a good tailing invariably followed unless we used an uneconomical percentage of per-sulphate. Finally, it was discovered that cyanogen iodide was an exceedingly good solvent for the telluride of gold, and it seems possible to form cyanogen iodide in a solution of this kind by the action of the per-sulphate upon the potassium iodide, the liberated iodine combining with cyanide forming cyanogen iodide:

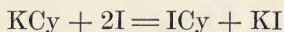

Knowing the similarity existing between cyanogen iodide and cyanogen bromide, and having some knowledge of the cyanogen bromide process, the experimenters worked upon the theory that the existence of cyanogen iodide depended upon the absence of excessive quantities of alkali. In following this out it was found

that low tailing resulted even with very weak solutions. A solution of 1 lb. cyanide, plus 1 lb. potassium iodide, plus 3 lb. alkaline per-sulphate per ton of solution, in a pulp of three of solution to one of ore, with 4 or 5 lb. of lime per ton of ore, gave on 1-oz. ore, ground to 100 mesh, tailings of less than \$1, with a consumption of cyanide of about 1 lb. per ton of ore. But the solutions after leaving the ore and standing in contact with the air, lost their cyanide, a hard thing to believe, as the same solution before being applied to the ore would stand in a beaker indefinitely with very little loss of cyanide. Even when in contact with the ore in a bottle this loss was not excessive, but when separated and left to stand, the cyanide in some cases disappeared rapidly. This loss was more pronounced when treating heavy sulphide ores; and it became apparent that it was due to the formation in the solutions of $\text{Na}_2\text{S}_4\text{O}_6$. Sodium thio-sulphate, $\text{Na}_2\text{S}_2\text{O}_3$, being formed by the action of the per-sulphate upon the pyrite, is probably further oxidized to $\text{Na}_2\text{S}_4\text{O}_6$.

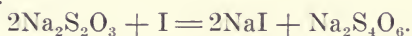

When the solutions are in contact with the ore, the reducing action of the ore aids in overcoming oxidizing influences, but when separated, the oxidation becomes more violent. The action of the air seems to have a marked influence on the cyanide destruction, as at any rate a decided difference in consumption is noted in using closed and open agitators. However, it was found that on passing the solution through the zinc-boxes, the deterioration of the cyanide is stopped, due undoubtedly to the reducing action there.

Experiments in a small way upon the manufacture of sodium per-sulphate by the electrolysis of salt cake yielded a product which, when used in bottle-tests, answered very well, so that it might be produced on a large scale at a reasonable figure.

Potassium iodide, although an expensive chemical, would remain as such in the solution, the per-sulphate causing it to give up its iodine, this iodine combining with the cyanide to form cyanogen iodide, or with the alkali to form an alkaline iodide, or alkaline iodate, but always finally reverting again to an alkaline iodide, as any iodate formed would be reduced to iodide in the zinc-box. Cyanogen iodide is certainly a wonderful solvent for gold tellurides, and its production by this method presents a possible field for ore-treatment. In the practice of using cyanogen bromide as a solvent, one of the troubles other than its cost is its rapidity of action, as it remains as cyanogen bromide only for a limited period, and does not act sufficiently long to cause the dissolution of the telluride of gold. One can, therefore, readily see that if it were possible to produce it in a similar manner to that described, a much weaker solution constantly in contact with the ore would have a decided advantage.

RESEARCHES UPON CRIPPLE CREEK TELLURIDE ORES

(January 15, 1910)

The Editor:

Sir—In the letters which were published in your issue of November 20 last and of December 25, referring to the article, 'Researches Upon Cripple Creek Telluride Ores', which appeared in your issue of September 25, 1909, your correspondents appear to be unaware of the fact that the discovery of the solvent action on gold in ores of a solution of cyanogen iodide and potassium cyanide is nearly as old as the cyanide process itself. W. H. Gaze proposed the use of this solvent about the year 1888, and in 1889 the first cyanide work which I did was some tests comparing the action of a plain solution of cyanide and the iodide solution on a gold ore. If the improvement in the solvent action of the solution is due to the presence of cyanogen iodide, it is difficult to see why such an expensive method of forming it should be proposed as the use of a persulphate and an alkaline iodide. There are much cheaper methods of making cyanide iodide. The use of cyanogen bromide ('bromocyanide') was strongly advocated at one time, but with the exception of a single mill in Western Australia one does not hear of its being in use. Not only the cost of the extra chemicals is against their usefulness, but to get any benefit from them great care has to be taken that the solution is neutral or slightly acid. By 'acid' is not meant acid to litmus, but that the solution contains a trace of free hydrocyanic acid. In the laboratory high extractions can be obtained by the use of extra chemicals, but it is often overlooked that the cost of these chemicals may be considerably more than the value of the larger amount of gold extracted above that extractable by plain cyanide.

BERTRAM HUNT.

San Francisco, December 29.

CYANIDE NOTES

(May 7, 1910)

The Editor:

Sir—In your issue of January 15, Bertram Hunt writes on 'Researches Upon Cripple Creek Telluride Ores', remarking that, "the use of cyanogen bromide ('bromocyanide') was strongly advocated at one time, but with the exception of a single mill in Western Australia one does not hear of its being in use." Evidently Mr. Hunt does not follow treatment in this State, or he would not write so. The original mill at Kalgoorlie using bromo. was the Hannan's Star, but this is now shut down, as the company is about to consolidate with the Lake View Consols, which has 75 stamps and one No. 5 Krupp ball-mill, wet-crushing, concentrating, tube-milling, agitation with BrCy, and filter-pressing at the vats of 11,200 tons per month, with about 90% extraction at a cost of \$2.46 per ton. The Oroya Links company has 50 stamps, Wilfley tables, tube-mills, agitation of slime with BrCy, and filter-pressing, at the rate

of 11,500 tons monthly, with 92% costing \$2.44 per ton. In connection with the milling results of these two mines, the former mine is dealing with a hard ore, and the ball-mill has just started, so it must not be taken into account: while in case of the latter mine, the ore is fairly soft. Another mill using BrCy is that of the Golden Horseshoe. Here 150 stamps—soon to be 200—are at work, with Wilfley tables, tube-mills, and grinding pans in series, agitation with BrCy, and filter-pressing. An average of 24,500 tons is treated monthly, and of this quantity about 17,000 tons are treated by this chemical with 90% extraction, costing \$2.80 per ton. Finally, we have the Ivanhoe mill, with 100 stamps, tables, grinding pans, sand, and slime treatment. Of the latter product, some 10,000 tons is treated by BrCy, the monthly output being over 19,000 tons. A little under 90% is extracted at a cost of \$1.90 per ton. I am not by any means holding forth on the merits of the BrCy process, being firmly wedded to the dry-crushing, roasting, and plain cyaniding for the sulpho-telluride ores of this field; but I simply wish to point out that Mr. Hunt is slightly in error on this point. There is one thing certain about the wet-crushing process here, that, if BrCy were not used, the extraction would be very low. Certain minerals in our ores are soluble in BrCy, but not in plain KCy, that is, in raw treatment. Is not the BrCy process being used on some arsenical ores, with a high percentage of arsenic, at Deloro, in Canada?

In an editorial in your issue of January 15, you had much to say about the Goldfield Consolidated of Nevada, which must be a wonderful mine. You said: "America can now boast of possessing the premier gold mine of the world, thus wresting first place from the Transvaal." Do you mean as regards the monthly or annual yields, or as to the value of the mine? Mr. Rickard once said that "The value of a mine depends on its present profits and its future development," or words to that effect. Now, a comparison between the Goldfield Consolidated, Homestake, Robinson, and Waihi mines present yield and future prospects, would be highly interesting. Which is the premier mine (gold) of the world? There is one laudable point about your Nevada mine, and that is its detailed monthly tonnage, costs, and mine development. Why don't all your American mines, whether working for precious or base metals, do likewise? We are compelled to in Australia.

M. W. VON BERNEWITZ.

Kalgoorlie, Western Australia, March 12.

[Our note about the Goldfield Consolidated had reference to present annual production. There are of course many bases for such comparisons, and each is, to some extent, unfair to some mine. The Goldfield Con. is setting an excellent example, as Mr. von Bernewitz notes, in the matter of fullness of monthly reports.—EDITOR.]

CYANIDING CONCENTRATE AT TARACOL, KOREA

By J. D. HUBBARD

(October 2, 1909)

The old percolation process is regarded as a bit out of date at the present time, but there are still odd corners in the mining field where conditions make it necessary. Here in Korea it has been found profitable, although far from the high metallurgical standard of modern practice. The 'modus operandi' obtaining at the cyanide plant of the Oriental Consolidated Mining Co., at Taracol, Korea, might be of interest to the metallurgical profession.

The concentrate treated consists of marcasite, 56% ; galena, 36; sphalerite, 6; and arsenopyrite, 2. These percentages vary on different levels in the mines, but do not affect the extraction of the precious metals contained, as all these minerals (with the possible exception of arsenopyrite) offer no great obstacle to successful cyaniding.

Sizing tests on this concentrate also vary from time to time, and these materially affect the extractions. Two sets of sizing-tests showing about the limits each way, are as follows, the results being the average of several tests:

No. 1		Per cent.
Screen.		
On 50	16.4
On 80	18.2
On 100	12.0
On 150	18.0
On 200	3.4
Passed 200	31.9

No. 2		Per cent.
Screen.		
On 50	23.4
On 80	20.1
On 100	19.3
On 150	19.1
On 200	4.1
Passed 200	13.4

In treating a product like No. 1 an actual extraction of 86% of the total head is obtained, and on No. 2, 80%. All the product passing a 100-mesh screen gives a high extraction by percolation (over 90%), but this would not be possible if the fine product were treated by itself, as it would pack heavily. It is necessary to have a certain amount of coarse material to afford a proper leaching medium. This coarse product, that is, all material that is caught on a 100-mesh screen, contains most of the remaining gold after leaching, and this is the main defect of the percolation process for cyaniding concentrate. It will be necessary to re-grind this coarser product to obtain a better extraction, and the company is planning to this end. A tube-mill and agitation plant is to supersede the percolation plant.

The present plant consists of 18 circular percolation vats, 22 ft. diam. and 6 ft. deep, of riveted sheet iron. A grating of wood

is fitted into each tank, 10 in. from the bottom. This allows the necessary space for air and solution. On this grating a burlap filter-cloth is placed, and carefully wedged down around the edges. On top of this burlap filter, Korean rice-straw mats are placed, to protect the burlap from the points of the shovels. Sixteen mats are used to cover each filter-bottom, and cost $22\frac{1}{2}$ c. each. They last one year, and the burlap filter-cloths from three to five years. These rice-straw mats are unaffected by strong cyanide solutions, and only have to be changed when the mesh becomes filled and cemented with fine concentrate. Aeration prolongs the life of both filter-cloths and mats, by forcing the fine concentrate up and out of the mesh.

Four settling tanks, each eight feet square and four feet deep, receive the gold-bearing solution from the percolation vats. One tank is used for wash-water, one for weak solution, and two for strong solution. Proper piping connects the percolation vats with the settling tanks. Aeration is carried on through the same pipes, by using an extra valve on each pipe from the main air-pump line.

Eight zinc precipitation-boxes, 14 ft. 10 in. long by 2 ft. $15\frac{1}{4}$ in. wide, are used for the precipitation of the gold and silver from the solutions. There are eight compartments in each box, each compartment 18 by 34 by 24 in. deep, and containing 9 cu. ft. of zinc shaving. One box is used for wash-water, one for weak and six for strong solutions. There are three circular, riveted sheet-iron sump-tanks, 25 ft. diam. and 10 ft. deep. One is used for strong solution, one for weak, and one for wash-water. Duplicate 4-in. centrifugal pumps handle the solutions with ease and economy. One pump is held in reserve in case of accident to the other. A Hampton zinc-lathe with 36-in. mandril, cuts the necessary zinc shavings. From 1800 to 2600 lb. of zinc shavings is used per month. Vacuum and air pumps, filter-boxes, a small crusher for slags and fluxes, also melting and roasting furnaces, complete the equipment. There is a well-stocked laboratory for testing and chemical analysis.

The fresh concentrate from the mills is trammed by gravity in one-ton cars to the cyanide plant, weighed on platform scales, and net weight of wet concentrate recorded in the scale-book. Two samples are taken from each car, one for assay and one for moisture. Care is taken that the sample-rod be driven to the bottom of the car, to insure a good sample. The day's run of fresh concentrate is then dumped into the vat ready for it. A few cars of coarse sand from the 'spitz' boxes in the mill are mixed in with the concentrate in the charge, at the discretion of the operator. The concentrate is drawn off the vanners in the mills with from 30 to 50% sand. This mixture has been found to be necessary in practice, to secure a good percolating medium, and a better extraction. Without the sand, the charge 'packs' in the vats, and a poor extraction results. Lime is also mixed with the charge at the rate of $2\frac{1}{2}$ lb. per ton. This gives us a protective alkalinity of between 0.50 and 0.60% (in terms of N/10 oxalic acid), which is just right for the solution. A lower protective alkalinity causes a higher

consumption of cyanogen, and a higher one causes a crust to form in the sump and main pipes of lime and iron carbonate. This caused considerable annoyance and loss of time, with the protective alkalinity at 0.70%, as the pipes had to be disconnected and the crust cleaned out. This question of protective alkalinity has been experimented on and discussed by many prominent metallurgists, with varying results. Some claim a regeneration of cyanogen by carrying a high protective alkalinity; the regeneration obtaining from the double cyanide of zinc, the alkali decomposing the same, forming zinc hydrate and liberating cyanogen. This is not the case here. After a series of careful tests, covering several months, on working and sump solutions, I found that excessive protective alkalinity did not regenerate cyanogen in the working-solutions, and but slowly in the sump-solution. Tests on a sump-solution allowed to remain quiet, showed a slight regeneration of cyanogen from day to day, until at the end of two weeks it remained stationary. The solution on entering the sump tested as follows, these results being the average of several tests: total cyanides, 0.48%, free cyanide, 0.23%, protective alkalinity, 0.76%. After one week the free cyanide increased to 0.26%, and after two weeks to 0.28%, where it remained. Tests on the main working-solution, constantly in circulation, did not show regeneration, and as the pipes caked so rapidly as to become ineffective in four days' to one week's time, I was obliged to drop the protective alkalinity to a normal point, which was found to be 0.55%. A few hundredths either way did not cause any inconvenience or loss. I hope to take this matter up more fully in a future article.

After the leaching vat is charged to its proper capacity, a wash of clean water is run on and allowed to percolate for 24 hr. This water is heated in winter. The water-wash carries out all soluble sulphides and acts on the lime, which removes all traces of acidity, and leaves the charge alkaline, and in a receptive condition for the cyanide solution. This wash is run directly to waste, as it is very low in value, 0.02c. being the average per ton of solution. This small value is taken mainly from the pipes in passing through.

In the past, a preliminary weak solution was run on the new charge, and allowed to flow through the weak zinc precipitation-box. It caused all kinds of trouble, a large quantity of the soluble matter settling in the head-compartments of the weak-precipitation box, necessitating the cleaning up of the same every other day. It also gave from 200 to 350 lb. of practically valueless matter in the precipitate, which had to be melted down with the rest on the clean-up. The preliminary water-wash does away with this trouble.

After 24 hr. washing, a strong cyanide solution is run on the charge (0.48% double cyanide, or $2\frac{1}{2}$ lb. KCy per ton of concentrate), and allowed to percolate for 16 days. Then a weak wash for 12 hr., and a water-wash for 12 hr., thence to the dump. The charges drain down to 18% moisture before going to the dump. Each charge is changed twice during its cycle of treatment (18 days), by shoveling over from one tank to the other. This labor

is done by the Korean coolies, 12 on each shift. The 18 percolation vats in use are divided into six series of three vats each. This allows two complete changes or turning over of the charge. One vat is discharged to the dump each day, and one vat is filled. At present the mill is treating 2100 tons of fresh concentrate per month, or 70 tons to each charge.

Aeration is carried on intermittently, two vats at a time, for a period of one hour each. A two-cylinder, clack-valve, plunger-pump, made in the company's Taracol shops, is used. It only consumes $3\frac{1}{2}$ hp., and requires little attention beyond oiling. Constant aeration is an important factor. Without it the total extraction not only falls off alarmingly, but necessitates a frequent renewal of working-solutions.

The gold-bearing solutions from the percolation vats are run to settling tanks, and from there to the zinc precipitation-boxes. The rate of flow for each box is $10\frac{1}{2}$ gal. per minute. The total extraction is excellent, the head varying from \$1.40 to \$3 per ton of solution, and the tailing from a trace to 0.06c. per ton. From the precipitation-boxes the solutions are run to the sumps, where they are strengthened by the addition of the necessary KCy, and from there pumped back onto the charges. Clean-ups take place twice a month. The first clean-up is not complete, only three or four of the head-compartments in each of the strong-solution boxes being cleaned. An accumulation of precipitate in these head-compartments, below the screen, prevents the free circulation of solution, necessitating a clean-up. The precipitate is run to a filter-press, where the solution is separated from the slime or precipitate by a vacuum-filter. When dry, the slime is removed to the strong-box to await the final clean-up at the end of the month. On the 30th of each month the regular clean-up is started. The strong-solution boxes, launders, filter-boxes, precipitate-box, and others are unlocked and made ready. The clear solution from the zinc-box compartments is siphoned off carefully and goes to the sump. The zinc is then removed and well scrubbed by the Korean boys. These Koreans are not as thick-skinned and immune to cyanide sores on the hands and arms as the Kaffirs, so each boy greases his arm to the elbow with vaseline. The slime is tapped off through the lower plug in each compartment, and run to the filter-box, and the vacuum-pump started. The compartment is then washed thoroughly, the plug and screen replaced, and the washed zinc put back. The short-zinc goes to the head-compartment in each box, and is all consumed by the following clean-up. Fresh zinc is placed in the compartments not filled by the old zinc. The practice here is to let the zinc run down pretty low in the compartments by the clean-up, thus giving less bulk to handle. Care is taken, of course, that the solutions do not 'channel' or make holes in the zinc, and it is found that the precipitation is just as good. Care is taken not to stir up or disturb the zinc shavings in the compartments during the month, but to add fresh shavings on top of the old, very carefully, when needed. Every time the zinc shavings are agitated or

stirred (to loosen the slime), a considerable loss occurs; much fine precipitate is carried over to the sump, where it is lost. As the precipitated gold is then in an allotropic form, it is not re-dissolved in cyanide solution, and consequently, when the sump-solution is pumped back for leaching, the precipitate is caught in the charge and lost.

An operator, in describing this slopping around of the zinc-shaving to shake the precipitate off, will say, "after allowing the slime to settle," the "solution is turned on." But if any operator can make this same slime 'settle' naturally, and a portion not rise and overflow the instant the solutions are turned on (I do not care if he settle them a full month), I will confess I have something to learn on that point. This class of practice parallels the decadent millman, who has his secret 'dope' to put in his batteries, thereby saving more gold from the ore than Nature originally put there. When the compartments get 'dead' or in bad shape, they are cleaned but never stirred up. After the boxes are all cleaned and the slime collected in the filter, and vacuum-filtered dry, it is removed to the precipitate-box, preparatory to roasting.

About 100 lb. of the slime is charged into the roasting pan, and spread out evenly. The furnace is then fired with wood. The slime is not disturbed until the pan-liner shows red through the cracks in the charge, and then the lumps are carefully broken with a hoe made for that purpose. This causes a minimum of 'dusting'. Continual stirring and breaking up of a charge in the pan always causes a maximum of 'dusting'. There is a hood over the pan, and dust-chamber 6 by 3 ft. 18 in. of riveted sheet iron, and using the greatest possible care in roasting, there was still obtained in the past year a little less than \$500 from the dust-chamber. When the roast is 'sweet', or will not show any sparks on stirring, it is carefully removed from the roasting pan to a fluxing pan, and then taken to the scales. The fluxing charge consists of 45% borax, 30 old slags (preferably from the assay office), and 25 coarse sand, and is mixed with the roasted precipitate while hot. This also avoids loss by 'dusting'. The coarse sand contains a quantity of pyrite, and this materially assists in the formation of the matte on the gold button. This matte is a benefit, as it keeps down the value of the slag. One month clean sand, free of pyrite, was tried, and scarcely any matte was formed, the slag running up in value.

A former operator here informed us that the iron to supply the "matte-forming element" was derived from "scales from the roasting pan," but this is not so. No iron scales are obtained until roasting the last charge is finished, and these scales are picked out and thrown with the slag, as they contain trifling amounts of gold. They will not even melt in the crucibles, but hold back when the gold button is poured.

The melting furnace consists of three circular pits, 30 in. deep and 22 diam. These pits are on three sides of the stack, and the roasting furnace is on the fourth side. Charcoal is used for fuel,

as it is the most readily obtainable. The price of either coke or oil is prohibitive. No. 80 black-lead crucibles are used, as they have proved to be the most economical size for this size of furnace. These crucibles are charged three times for each melt, and then poured into a conical mold. When cool the top slag is knocked off, and the gold button with the matte-capping put in the safe.

American or English crucibles are good for from 14 to 20 melts, while the Japanese crucibles are only good for 7 to 11 melts, although cheaper in price. The American or English crucibles have proved to be the most economical in the long run here. After the month's run of slime is all melted down into buttons, the matte is separated from the gold and put through the crusher. It is then charged into the crucible with alternate layers of borax, matte, cyanide, and sand, and given two full heats in the furnace to 'cook' it thoroughly. The sand retards the reducing action on the crucibles, thereby prolonging their use. The resultant button is high in silver, and contains a small amount of gold. An average bullion-assay on the matte-bars gave, gold fineness 42.96, silver fineness 269.51, and base 687.53. Sometimes the silver will run up to 600, but the gold remains the same. The gold buttons are run into bars. The slags from the clean-up assay from 22 to 60c. per pound, and are treated in a special blast-furnace.

There are two other cyanide plants on the concession, one at Candlestick, and one at Kuk San Dong. The Candlestick plant is shut down at present, as the mine was behind in development. When it starts again there will be some radical changes, as the agitation process did not prove altogether a success. The chief troubles were the high cost of treatment, and the errors made in the mechanical construction. In practice it was found that the agitation plant was only able to handle the pulp from five stamps, instead of ten. The extraction was good.

The Kuk San Dong cyanide plant is operating on a low-grade concentrate with satisfactory results. Practically the same conditions obtain there as at Taracol, and the same process is used. It is intended shortly to install tube-mills for re-grinding the concentrate, and change the plant, to secure the highest economical extraction of the gold and silver in the pulp.

SLIME

(October 9, 1909)

The Editor:

Sir—As an index of the general acceptance by metallurgists of the value of 'sliming' gold and silver ores, it is noted that Alfred James, in his review of the progress of cyanidation for 1908, states that it was reported that some 5,000,000 tons of slime were treated by vacuum-filters during the year. It is but a very few years ago that slime was treated as a necessary nuisance to be disposed of as efficiently as possible, and efforts were largely directed toward seeking means to secure the crushing of ore in such a manner as to

produce a minimum of slime, but the realization of the fact that in many ores the gold and silver were in an exceedingly fine state of division, and that fine grinding liberated more completely the minute particles in a form particularly suited to the action of the cyanide solution, led to a large adoption of the 'sliming' treatment, converting what had been heretofore an undesirable by-product into the chief form of output. The transformation of method was greatly stimulated by the means that were developed both for producing slime and handling it, the former aiding materially in the attack of the solution on the metal content of the ore.

In crushing rock it is broken into fragments of varying sizes down to impalpable powder which settles but slowly, even in still air. Both the physical and chemical characteristics are usually complex, and it seems, so far as results are concerned, that an exact definition of the term 'slime' is not necessary beyond a determination of its susceptibility to ready treatment by the solution. Usually this fine product in any considerable mass is impermeable, and hence should be treated in detail, so to speak, in a manner so that each particle may be brought into sufficient contact with the solution. This is brought about in present practice by agitation in tanks provided with means for mechanical or air agitation, requiring a number of hours for the purpose, and afterward allowing a partial settlement to take place, following by the decantation of a portion of the solution before turning the pulp into the filters, all of which requires a large tank-capacity and the consumption of much time.

There is probably no better condition in which the pulp could be placed after it has left the tube-mill, or other pulverizing machine, for the extraction of the metals than its course through the launders, where, in a comparatively thin stream, it is subject to agitation, aeration, and the attrition of the particles against each other and the launder, all aiding in the solution of the metal. It is worthy of consideration whether a sufficient extension of the launder system, aided by some pumping facilities to supply defects in fall, might not be an economy in space, time, and tank-equipment, and produce better results. It is interesting to note, in this connection, that in the method recently introduced in the Simmer Deep and the Jupiter joint mill in the Transvaal, as briefly described in the *Mining and Scientific Press* of July 10 last, the de-watered sand which is washed by a 0.3% solution from the filter-tables to the collector vats has 50% of its gold dissolved in the passage.

Two general types of vacuum-filter have been developed for the purpose of handling the slime after the extraction has been completed, although there are many varieties of these. One of them is dependent upon the accumulation on the filter surface of a cake of the solid portion of the pulp by means of suction in opposition to gravity, and the final disposition of the cake by dropping it through the medium of gravity, assisted by a reversal of the pressure previously applied, and by more or less scraping. In this type the homogeneous character of the cake is an element of great importance,

for on it depends the successful washing, and great care is necessary in transferring from the pulp to the wash-water so that the cake be not too much dried, which tends to produce cracking, thus reducing the efficiency of the washing. While in this type of filter it is possible to present a very large filter-surface in a small floor-space, great care is necessary in the accumulation of the cake, which accumulation seems to be facilitated by the use of a thickened pulp in which any tendency to the settlement of the heavier solids is retarded by the thickened condition of the mass, otherwise, in the height of the leaves of the filter, there would be a decided difference in the density of the cake at the top and bottom. An interesting difference appears to exist between the basket type of filter and the Ridgway form, consisting of the small horizontal filter-frame, which is dipped first into the pulp, and which rapidly accumulates a cake about $\frac{3}{8}$ in. thick, then automatically dips the cake into the wash-water and afterward dumps it by a reversal of pressure. The basket-filter exposes from 50 to 75 sq. ft. of surface per ton of daily capacity, while the surface of the Ridgway exposes from 1 to 2 sq. ft. The former receives its charge of 1 in. in 30 to 60 minutes; the latter accumulates $\frac{3}{8}$ in. in 13 seconds; or assuming the 50 ft. exposure and the 30 minutes time in the one case, and the 1 ft. exposure and the 13 seconds time in the other, this would result in 144 cu. in. per square foot in 30 minutes in the one case, and 7452 cu. in. in the same time in the other. These figures are not cited as absolutely representing the relative merits of the two forms of filter, although such have been reported as their accomplishments. They serve to indicate, however, a great difference in point of time in the accumulation of a thick and thin cake under the respective conditions, and further point to a possible advantage in the attack in detail instead of in masses. The basket type of filter might be denominated 'the adhesion type', from the method of accumulation and of holding the cake as distinguished from the other type to which I have referred, in which the accumulation of the cake is accomplished by a vacuum, aided by gravity, and its final disposal by mechanical means. In the latter type the thickness and uniformity of the cake are not matters of such prime importance; the chief aim is the separation of the filtered solution from the solids, in the accomplishment of which there is a vastly greater latitude with respect to the condition of the cake than in the former, in which the homogeneity of the cake is an essential to the successful operation.

This type embraces the horizontally revolving filters, and differs in principle from the other mainly in the reversal of the application of the force of gravity. It might be denominated as the 'upright' or direct method of filtering in contra-distinction to the 'adhesion' system. By dealing with smaller quantities at a time, and presenting cleaned surfaces to the pulp, it participates in the advantages of the attack in detail, if such there be. It results in a very simple device, automatic in operation, and in which the cake is in full view at all times; it is equally applicable to coarse

or fine material or both together; in fact, in particularly impermeable material the addition of sand would considerably aid the filtration; nor does the particular character of the cake injuriously affect the washing which is not accomplished by flooding or submersion. Just sufficient water is used to thoroughly wash out the remaining valuable solution, all of which is retained, and there is no liability to loss from osmosis. The wash-water is applied uniformly over the cake in small quantities, and is drawn through at the point of its application and may be applied at different points of the cycle in such a number of successive applications as may be desirable. With the numerous successful means of handling slime, the two general types of which I have endeavored to briefly review here in so far as they include the vacuum-filters, the early slime bugbear to the cyanide man has been quite thoroughly eliminated, and the problem has been relegated to the pulverizing device for determination as to how far the fine-grinding may be profitably carried.

EDWARD PARRISH.

Newport, Rhode Island, September 21.

ASSAY OF CYANIDE PRECIPITATE

By FRANK A. BIRD

(October 9, 1909)

Although an abundance of information upon the cyanide process is published in the *Mining and Scientific Press*, I have failed to observe any upon the present-day practice of assaying the precipitate. Believing that such will be of value to readers of the *Press*, I herewith submit the methods as commercially carried out in the Salt Lake district.

First method. While no special directions as to fluxing for the preliminary fusion are necessary, the following flux-mixture has been found to give perfect results. It can also be used as a fire-assay lead-flux, and, with the addition of litharge, for silicious gold and silver work.

The following is the flux-mixture:

	Per cent.
Sodium carbonate (soda ash grade), 4 lb.....	38.1
Potassium carbonate, 4 lb.....	38.1
Flour, 1½ lb.....	14.3
Borax glass, 1 lb.....	9.5

The crucible charge consists of: 18 gm. flux-mixture, having a reducing power of about 25 gm.; 3 gm. borax glass; 50 gm. litharge.

This thoroughly mixed in a 20-gram crucible, and then $\frac{1}{10}$ assay-ton of precipitate, which has been carefully weighed upon a delicate analytical balance, is added and again mixed well, the mixing spatula being brushed into the crucible as it is removed; a light cover of soda is then added. About nine crucibles are prepared in this manner, three of which will be used for the silver assay alone, the balance for the gold. The prepared crucibles are placed in a muffle at not too high a temperature, although no spe-

cial precautions are taken to have it extremely low for gold-precipitates. After quiet fusion is attained the crucibles are heated intensely for a half-hour, the furnace being fired lightly about every 10 minutes. As the melts are poured, cover each with an inverted scorifier to prevent the slag flying as it cools. Slag and cube the buttons, as usual, saving the three slags representing the silver part together, and the six for gold together. As it is necessary to know the approximate gold content of the sample the three buttons representing the silver assay are first cupelled; as this cupellation finishes, a play of colors will be noticed upon the button wholly unlike any ordinary cupellation; this is due to some zinc which has been reduced and has remained throughout the operation; it may be necessary to push the cupels a little farther back in the muffle before this totally disappears, and it may last from five to ten minutes longer than would the ending of an ordinary cupellation. Clean the buttons over a pan containing slags, and to which the cupels, cleaned free from unused bone-ash, have been added. The buttons are weighed and entered in the work-book as ounces of gold and silver.

To the six lead buttons, representing the gold assay, are added five times the weight in milligrams of the cupelled silver buttons, and ten milligrams of pure copper, which will prevent the buttons spitting as they finish. These are then cupelled in the ordinary manner, no special precautions being necessary. After brushing the gold buttons over a pan containing the six slags and cleaned cupels, they are placed separately, without any flattening, in parting capsules containing hot nitric acid (2 parts of acid to 1 of water). Parting proceeds quite vigorously, the gold flouing into one sponge; should it be necessary the buttons are assisted in breaking up with a glass rod, but if the specified quantity of silver has been used, and the parting-acid is hot, and of the concentration indicated, it rarely happens that they require any further attention than most careful watching and regulation of the heat of the parting-plate. After the parting finishes, decant the acid and add another quantity of the same as a precaution; heat cautiously, as it is inclined to 'bump', and continue about 15 minutes after steam begins to show, then decant, wash twice with ammonia water and once with pure distilled water, dry very carefully, burn, weigh, and enter in the work-book as commercial gold assay. This deducted from the ounces of gold and silver makes the commercial silver assay.

Working by this method reduces to a minimum the chances of reporting silver with the gold. I have dissolved gold buttons which had been alloyed with three times their weight of silver and parted as coronets, and found that they contained as much as 13 oz. silver.

The two sets of slags and cupels are first weighed, and then crushed to about 30 mesh. Two crucibles are run for silver and four for gold, the quantity taken being the nearest 50 gm. the total weight can be subdivided into. The charge is as follows:

18 gm. flux-mixture, 10 gm. borax glass, 6 gm. fluorspar, 30 gm. litharge, 50 gm. slag and cupel mixture.

Mix well in the original crucibles, cover lightly with soda, and fuse at not too high a temperature, as it boils badly and requires constant watching; add salt as usual when the danger point is reached. When quiet fusion is attained heat at a high temperature, the same as was done with the precipitates, pour and cupel as usual; the gold buttons can be parted direct, sufficient silver being present. Weigh the buttons in fractions of milligrams and calculate to the weight of the total mixture, and then to ounces; deduct the weight of the pure gold found from the silver buttons, and then add each to the commercial assays, which makes the corrected assays for report.

Metallies are usually received finely divided; these, when submitted with the fine material, are assayed the same, about two crucibles for silver and four for gold being run; if the precipitate assays low in silver no correction is deemed necessary, but one is always made for gold.

The above method outlines the scheme as applied to gold precipitate. Silver precipitate is assayed in precisely the same manner; the first fusion, however, must be commenced with an extremely low heat, the muffle gradually being brought to redness as the fusion proceeds, otherwise the results are low, probably from volatilization. Six crucibles are enough for the gold, each button being parted separately with one part of nitric acid to eight of water.

Second method. This is applicable to gold precipitate, but not to silver. The preliminary preparations are the same as in the first method, but only six crucibles are necessary; cupellation must be carried out as the assay for silver, otherwise any zinc not driven off will be reported as gold. The gold-silver buttons, having been weighed, are dissolved separately in aqua regia (1 part nitric acid, 3 to 4 parts hydrochloric acid, these to be diluted once). The gold dissolves quickly, the silver precipitating as chloride; after solution of the gold, dilute to about 100 c.c. and stir well, allow the silver chloride to settle, then filter upon small paper; wash thoroughly with cold water, place in scorifiers, carbonize in the front of the muffle, then add 30 gm. granulated lead, a pinch of borax glass, and scorify; cupel and weigh as the commercial silver assay, and this deducted from original weight gives the commercial gold assay. As a precaution, buttons may be parted for gold; none should be found. The slag and cupel-mixture from the crucible assays must be assayed for gold and silver, about two crucibles for silver and four with an addition of silver for gold; the scorification slags and cupels should also be run for silver. Instead of mixing all the slags and cupels together, a slag and cupel from each assay may be pulverized together, then divided into two parts and run in the original crucible, and in one new one, the two buttons being weighed together and added to their assay.

Although methods have been applied recommending the all-scorification method in preference to the crucible, my experience has been that while the commercial assay is higher the corrected assay is far below. I believe the crucible assays, as outlined above,

answer every purpose, and are equal to any method used in present practice. For gold work only, commercial litharge will be found as satisfactory as the higher-priced chemically pure article. Cupels are preferred that are very soft; this is accomplished by making the bone ash barely moist with water and compressing very lightly. Nothing but the bone ash and water is ever used.

CONTINUOUS COLLECTION OF SAND FOR CYANIDING

By W. A. CALDECOTT

(November 13, 1909)

*Given adequate plant, a total residue of only one-third of a pennyweight of fine gold per ton of ore, equivalent to 93% extraction on 4.8 dwt. ore or 96% on 8.3 dwt. ore, is usually obtainable with profit on the Rand.

The capital expenditure on plant still remains absolutely high for a huge modern plant handling several thousand tons of ore daily. As regards the secondary treatment, I was authorized in the beginning of 1907 to endeavor to effect some saving in the cost of the usual cyanide plant. It appeared that the most likely prospect of success lay in eliminating the sand-collecting vats, or rather in utilizing them for treatment purposes instead of merely as sand-storages, which take the place of the old tailing ponds. The upper vats of the superimposed type of sand-plant were, on their first introduction before the war, utilized as treatment-vats as well as sand-collectors, but the results of contamination of mill-water with cyanide caused this practice to fall into disuse, and in any case a considerable time elapsed between the filling of a vat and its charge yielding gold-bearing solution to the boxes. Hence, although it reduced cost of transfer to a minimum, this type of plant fell into disuse as being expensive, and having only one-half its capacity available for extraction purposes, and was replaced with separate blocks of collectors and leachers (with belt or truck transfer) in the ratio of 1 to 2 or 2 to 5, which is now the common practice.

The use of conical classifiers appeared the most ready means of removing the great bulk of the slime and water, and in the early part of 1907 I tried at the Knights Deep-Simmer East joint plant various combinations of such classifiers with other devices for removing the surplus moisture from the thick sand-pulp underflow of the classifiers. The ordinary type of slime-filter with vertical filter-leaves was obviously inapplicable, and a continuous action was desirable, while the question of washing the sand-cake on the filter did not arise at this stage. A practicable centrifugal separator with continuous discharge was not known to exist, and finally a horizontal type of vacuum-filter appeared the most feasible device. The first filter constructed on this principle was a horizontal launder with false filter-cloth bottom, below which a vacuum was main-

*Abstract of paper read before the Chemical, Metallurgical & Mining Society of South Africa.

tained. The sand-pulp was continuously fed into the filter-laundry at one end and scraped slowly forward by a belt scraper-conveyor to the other. But a certain measure of success was thus attained, the continuous movement and disturbance of the layer of sand-pulp undergoing filtration prevented efficient removal of moisture, and the trial of another filter of the same type, but with a worm scraper-conveyor, yielded no better results. Finally there was installed a slowly rotating horizontal filter, which proved so satisfactory that little modification, except increase in dimensions and variation in details of driving mechanism, has since been made. This sand-filter (see p. 307) was 10 ft. in external diameter and consisted of an annular laundry 12 in. wide containing a filter-cloth as a false-bottom. The filtering area was thus 28.3 sq. ft. The space under the filter-cloth was connected by means of radial pipes to a central hollow spindle, in which a vacuum was maintained from a receiver. To the lower portion of the receiver was connected a water-pump and to the upper a vacuum air-pump. This filter gave such promising results, by handling sand in unwashed sand-pulp at the rate of up to 200 tons per day, that another, 15 ft. in external diameter and with 18 in. filtering breadth, was constructed at the Knights Deep. Among other results over 1600 tons of sand were collected by this filter and transferred by belt to the leaching vats, and when treated yielded somewhat better extraction than usual.

At the present time the underflow of the primary cones at the Simmer & Jack, being too low to gravitate upon the table, is mixed with slimy water from the tailing-pulp to form a fluid pulp and pumped into a secondary cone, placed above the table and delivering upon it a thick flow of pulp containing about 30% of moisture. To ensure a thick steady underflow of pulp in large amount, a disc, which I have termed a diaphragm, is placed near the bottom of the cones, which are run nearly filled with settled sand. This device has been adapted for tube-milling classification. The sand from which the surplus moisture is removed during the almost complete circuit of the filter, is continuously scraped off by a fixed incline plow some three feet behind the point of onflow. It falls into a hopper where it mixes with a stream of cyanide solution and is pumped to the distributor of the collecting and treatment vat, from which the solution overflows to a solution-storage and is returned by a pump to the hopper, thus completing the circuit. In this way the transfer of the sand from the filter to the vat is effected as a pulp, and an excellent start on the dissolving operation is made by the agitation and aeration the sand undergoes in the pump, and during its travel along the delivery pipe or laundry to the collecting vat. The system of solution transfer has the advantage of great flexibility and relatively small cost of installation, while the operating cost is mainly that of power and maintenance of centrifugal pump liners and propellers. The dissolving of the gold in the sand hence begins on falling into the hopper, within half an hour after the ore is crushed, and by the time the vat is filled and drained half the gold in the sand is dissolved.

An important feature of the Simmer & Jack trials was the determination of the relative extraction yielded by completing the treatment of the sand in the vat where collected, as compared with the result of transferring the charge by truck after first treatment to another vat, but the final result was much the same; yet the transfer, and consequent aeration of the particles while moistened with cyanide solution, ensured a quicker dissolution of gold, so that while six days actual treatment sufficed with transfer, nine days was required to complete the single-vat treatment.

The 15-ft. table has been in regular use from the end of last year and has handled up to 10,000 tons of sand per month. The following comparative results are averages from January to July, inclusive of ordinary and continuously collected sand:

	Continuous collecting.	Ordinary system.
Tons of sand treated monthly.....	7,937	37,009
Grading analysis—		
+ 60 (0.010 in.).....	12.9%	10.9%
— 60 + 90	32.7%	24.1%
— 90 (0.006 in.).....	54.4%	65.0%
Ratio of solution to sand applied as washers to charge	1.54 to 1	2.02 to 1
Number of days treatment in second vat after truck transfer	4.09	6.50
Percentage extraction	82.878	81.594

It will be observed that owing to the more perfect elimination of slime the sand-filter product is coarser and richer than the ordinary sand, and that the solution precipitated and the time of treatment in the secondary vats are much less with filter-table sand than ordinary sand.

Early in the present year two 20-ft. diam. sand-filters, each with a filtering launder 30 in. wide and 137.5 sq. ft. in area, were installed at the Simmer Deep-Jupiter joint plant, and after some preliminary runs have handled all the sand produced during the last five months, up to 2600 tons of ore being milled at times per 24 working hours. The capacity per square foot of filtering area of the Simmer Deep sand-filters is about 50% greater than that of the Simmer & Jack filter, owing to the slime being so thoroughly washed out that less than 1% remains in the collected sand. As a rule, the vacuum varies between 3 and 10 in., and the vacuum air-pump and tables each require about 5 hp. to run. The pump drawing water from the receiver in which the vacuum is maintained requires about 3 hp., as does also that supplying the glands of the centrifugal pump which elevates the sand-solution pulp to the collecting vats. The last pump mentioned is the main source of power consumption and requires 40 hp. The plow is merely a thin steel sheet with a renewable wearing edge, and is capable of being raised and lowered so as to periodically remove the top compacted layer of the permanent bed. The maintenance on the slow-moving tables (about one revolution in three minutes) is practically nil, though the usual wear on the centrifugal pump in handling even some sand takes place.

The recent remarkable development on the Rand of centrifugal pump elevation of pulp has greatly assisted in developing the method of solution-pulp transfer, and obviously the same plan could be adopted for transferring sand from the collectors to separately placed second-treatment vats, but for new plants the superimposed vat system, when only shoveling down is needed, is still simpler and cheaper. The solution required for pumping the sand as pulp is about four or five by weight to one of sand; the ratio is kept as low as is compatible with the grade of the delivery launder or pipe. While collection is still proceeding, and before the vat is filled, the leaching off of solution from the vat is begun, and after the vat is filled as much more wash-solution is applied as there is time for before transfer, with the result that half to two-thirds of the gold content of the sand is in the zinc-boxes before transfer begins, and before treatment would commence at all under ordinary practice. Before delivering the sand-solution pulp to a collector the latter has three or four feet of precipitated sand solution pumped into it, the exact amount being regulated by that which is regularly withdrawn from the solution transfer circuit in the shape of solution leached from the collectors for precipitation; in this way an equilibrium of the stock of transfer-solution is maintained, and at the same time its gold value is kept low, being usually under 0.2 dwt. per ton. It is found that the best work is done and driest sand obtained with the lowest vacuum; owing to the greater volume of air being drawn through with a more porous permanent bed; when the air has thus been renewed the moisture in the sand removed is about 13%, and this percentage slowly rises to, say, 19.5 immediately before the next renewal.

The slime overflowing the sand-collector carries with it a small amount of fine sand, as is usual with a distributor, especially when the vat is nearly filled with sand. This sand may be intercepted on its way to the solution-storage by means of one or more cone-classifiers, with the underflow gravity back to the sand-solution pump. As, however, the accumulated slime in the bottom of the solution-storage is periodically pumped to the slime-plant with solution, the fine sand may be removed at this stage by cones.

One somewhat unexpected result of the cone classification in the sand-filter installation is the appreciable increase in the slime tonnage, which may be taken at about 40% of the weight of the ore in place of, say, 32% otherwise to be expected. This is mainly due to the separation as slime in the conical classifiers of 200-mesh sand.

The collecting vats employed to receive the almost slime-free sand-solution pulp may be of larger dimensions than usual, as settlement of slime in layers is not to be apprehended, and fewer larger units thus employed in place of more smaller ones. For the same reason the bulk of the lime used may be crushed with the ore in the battery, thus reducing the separate grinding of lime in a ball-mill or other machine to occasional periods when unusually acid ore is being delivered to the battery. Naturally the use of sand-filters

greatly increases the capacity of existing plants, whether of the superimposed or other type, by converting all the collectors into treatment vats. The advantages which sand-filters present are considerable saving in capital expenditure, both for sand-vats and belt or truck installation, slightly better extraction than the ordinary system, unless prolonged treatment is given, a saving with superimposed vats of belt or truck transfer cost, and more slime to be treated as such at, say, 6d. per ton less than sand in vats of slightly increased diameter. Evidence as to reliability in practice and low cost of operation has been given, and considerable extension of continuous sand-collection, both for new plant and for increasing the capacity of existing plants, is now being designed or is actually in process of construction, so that within a year the present fifty-odd thousand tons of sand handled monthly by this method on the Rand is likely to be doubled or trebled.

OLIVER CONTINUOUS FILTER

By A. H. MARTIN

(November 27, 1909)

The Oliver continuous filter is the invention of Edwin Letts Oliver, metallurgical engineer for the North Star Mines Co., at Grass Valley, California. The filter consists of a rectangular wood or steel tank in which is partly submerged a filter cylinder revolving once every five or six minutes. The tank contains the slime, which is kept at a constant level by an automatic float. The filter-drum, through which passes a hollow trunnion, is composed of wooden staves mounted on cast-iron spiders. The surface of the cylinder is divided into 24 compartments, each section attached to an automatic valve by both blow-pipe and vacuum-pipe, for the connection of suction and of compressed air, respectively. The outer periphery of the compartments is covered with a specially prepared filter medium, in turn covered with light canvas. The entire drum is wrapped with hard steel wire. Against the side of the cylinder, resting on the wires, is a flexible steel scraper, designed to assist the removal of the slime-cake.

The first filters built two years ago were 7 ft. long and 10 ft. diam., and have an approximate hourly capacity of two tons. All other filters operating in Mexico and this country are 11 ft. 6 in. diam., and of lengths varying from 7 to 14 feet.

When the formation of the cake is commenced a vacuum is applied to the vacuum-pipe by means of the automatic valve. The suction is equivalent to about 22 to 25 in. of mercury. The suction causes a cake of slime, from $\frac{1}{4}$ to $\frac{1}{2}$ in. thick, to adhere to the submerged section of the cylinder. As the cake emerges from the slime it is dried to a consistence of about 30% moisture. A wash is then applied, which removes the last traces of dissolved gold and silver, and compressed air at 5-lb. pressure is admitted through the pipe to the section opposite the scraper. The vacuum is temporarily shut off at this section automatically, and the air admitted,

which causes the cake to detach from that section and slide down the scraper, from which it is removed by a spray of water, or by a belt-conveyor in case abundant water is unavailable. The change from suction to pressure takes place in one compartment immediately before reaching the scraper, and, after passing, the suction is at once restored. All of this is accomplished automatically. The cleaned canvas again passes into the slime and is ready for another cycle. It is thus seen that the action of the filter is continuous.

The weight of pulp on one side of the filter nearly balances the weight on the other, and but little power is required for operation, 10 hp. being ample for a 100-ton plant, including power for filters, vacuum-pump, and compressor.

Four of these filters have been in use at the North Star mines for two years, two at the North Star cyanide plant, and two at



Fig. 72. OLIVER SLIME FILTER

the Central cyanide plant. They have a capacity of 40 to 50 tons each, and have been treating a sticky clay slime, free from sand, and they have given excellent satisfaction. Practically a total recovery of the dissolved metals is accomplished, the residue showing less than 5c. per ton dissolved gold, even with the treatment of high-grade slime, which frequently occurs at these mines. Freedom from shut-downs, and small costs of labor and repairs, have tended to make these filters popular.

In addition to the filters in use by the North Star Mines Co., twenty are used in Mexican mills and American plants. Both gold and silver ores are being treated, and results have been satisfactory

in every instance, high-grade ores being as thoroughly washed as low-grade. The principle involved is a new one, and the filters are attracting the attention of metallurgists whenever they have been introduced in a new district.

Below is given a summary of costs of treating slime at the central cyanide plant of the North Star Mines Co. The mill-tailing is classified into sand and slime, and concentrate from the tables is also treated, so that one-third of the labor at the plant is charged to each product treated. As the tonnage is relatively small, the labor-cost bears a large proportion to the total cost of treatment.

	Cents.
Labor, including superintendence and office expense.....	12.2
Cyanide	14.0
Zinc	2.0
Lime	2.0
Sundry supplies and all extras.....	3.0
Power, 8 hp. at \$4.....	1.6
Filtering, maintenance, covering, etc.....	0.3
Lubricants, pump-repairs, supplies, etc.....	0.5
Total cost of slime treatment.....	35.6

Maintenance of filters in detail is shown by the following total costs for a period of six months, which is the average life of a filter-cloth.

Filter-cloth No. 12 duck.....	\$8.00
Burlap, 10 oz.....	2.00
Steel wire, No. 16.....	6.12
Extra labor, 1 man, 16 hr.....	5.00
Sundries	1.50
Total maintenance for six months.....	\$22.62
Total tons filtered	7200
Cost per ton filtered.....	0.3c.

(July 24, 1909)

Below follow data in regard to the operations, cost, etc., of Oliver filters at Minas del Tajo, Rosario, Sinaloa, Mexico, on a 130-ton slime-plant. The equipment is: two Oliver filters of 300 sq. ft. filtering surface each, being 11 ft. 6 in. diam. by 8 ft. wide; two dry vacuum-pumps, 6 by 7 in., at 150 r.p.m.; one duplex compressor, 6 by 6 in., at 160 r.p.m, single-acting; one duplex-plunger wet vacuum-pump, 4 by 6 in., single-acting; one 2-in. centrifugal pump for charging filters; necessary shafting and fittings for the above, as they are belt-driven; one 20-hp., 220-volt, direct-current motor which shows 55 amperes (about 16 hp.) when filters are working at the rate of 173 tons of dry slime per 24 hr., vacuum-gauge reading 24 in. (26 to 28 in. can be obtained at sea-level by using larger vacuum-pumps). The average for six months of filter-pulp is 3 oz. silver, \$1 gold per ton of slime; discharged pulp, 1.2 oz. silver, 18c. gold per ton of slime; filter-pulp, 1.22 sp. gr. or 2.3 tons of solution to one ton of dry slime; moisture discharged in slime, 35%; assay of solution saved, 1.3 oz. silver, 0.033 oz. gold, 0.117% KCN, and

0.03% CaO; soluble-metal values in discharged slime, 0.12 oz. silver, trace of gold, and 0.35 lb. KCN per ton of dry slime. These two filters working 18 hr. per day treating 130 tons of dry slime, make 15 rev. per hour. There is no increase in solution due to the wash-water. The water added is practically equal to the moisture discharged. It is found necessary to clean the cloth every two weeks with hydrochloric acid. This operation takes from 1½ to 2 hours. It is asserted by users that the power and labor saving is an important feature; that a greater saving of KCN is made than with any other type of filter, while the operation of the filter is absolutely continuous. The costs have not been figured in detail. Before the installation of the filters it was \$1; after the installation of the filters the cost of treating the slime was reduced to 75c. per ton. The cost of operating and maintaining the filters has not been figured exactly, but will not exceed 20c. per ton of dry slime.

GRAPHITE—AN OBSTACLE TO GOOD CYANIDING

By M. W. VON BERNEWITZ

(December 4, 1909)

Graphite occurs in gold mines in different parts of the world; and in several instances it has proved to be a great nuisance in the treatment of ores by cyanide. In the treatment of the sulpho-telluride ores of Kalgoorlie, it was noticed in certain mills that the extraction occasionally fell off for no apparent reason, although all conditions were favorable for good work. Ore from certain parts of the mines was known to contain graphite, and it was when this class was being milled that the trouble occurred. In the mines on the eastern side of the 'Golden Mile', the Brownhill, Associated Northern, Oroya, and Associated, the three first named working solely on the well-known Brownhill lode, and the latter partly on the south end of it, the graphite is found in the slate or schist in fair quantities. In the Brownhill it is not important in this connection. The graphite occurs generally on the hanging wall of the lode, but without doubt there are numerous seams through the lode itself. This appears from the fact that even if the hanging wall material is sorted out, a little graphite still comes to the mill. In the Associated Northern, pockets of almost pure graphite are sometimes found. The mineral occurs on the walls of the lode in the Great Boulder mine, and in the Lancefield mine, some 200 miles north of Kalgoorlie.

When breaking down ore in the Associated Northern, the graphite can, to some degree, be picked out; but where it is finely distributed through the ore this cannot be done, and it remains to complicate the subsequent treatment. In the dry-crushing mills, during the roasting of the ore no doubt some of the graphite is burnt, but the bulk remains unchanged. When the roasted ore is mixed with the circulating waters the trouble commences. The graphite forms a scum on the pulp in the grinding pans, collects on the overflow lip, and from here no doubt a great deal floats away

with the slime to the settlers. Likely enough a little may go to the agitators with the thick slime, although as regards the latter point there is no proof. The circulating waters are weak KCN washes (about 0.04%) from the filter-presses, and contain from 50c. per ton or more in gold. I think there is little doubt that a precipitation of the gold takes place while the graphite is in violent agitation with the pulp in the pans, and probably some precipitation in the settlers. As to it taking place in the agitators with 0.08% KCN, no means are available for determining. Extraction generally drops from 2 to 5% when graphite is present, varying with the grade being milled. Scum collected from the pans was filtered and washed carefully, and assayed. In the cupel a fair sized bead of gold was seen, but as the quantity assayed was small and there was nothing definite as to the amount of graphite in the ore, no calculation of its value was made. It seemed clear, however, that the graphite had precipitated this gold from the circulating solutions. The graphite schist from the mine gives only a trace by assay. It may be mentioned that there is a good deal of gold dissolved by the circulating solution in the pans and settlers, as well as in the agitators. An analysis of the graphite slate or schist is as follows:

	Per cent.
Insoluble (silicious matter)	86.80
FeS ₂	3.28
Fe ₂ O ₃	4.53
Al ₂ O ₃	1.40
CaO	1.40
MgO	0.25
C (graphite)	0.75
H ₂ O, and undetermined	1.59
	100.00

By increasing the final heating in the furnaces a good deal of the graphite would be destroyed, but such heat would sinter the ore, which is undesirable. A sample roasted in a muffle-furnace resulted in the graphite being burned off, but the conditions in a muffle and those of a roasting-furnace are entirely different. In roasting this sample the ore was well stirred, and when agitated with gold solution the extraction was all right. Other samples of ore, roasted, but not stirred much, and agitated with solution for 16 hours, showed poor results. It has been suggested, and tried, that the grinding should be done in fresh water, as the graphite would not have the same chance to precipitate any gold. This is all right, but it would require running to waste a good deal of spent solution every day, which would hardly pay, since the manager seldom knows when the graphite is coming into the mill. Being finely distributed in some classes of ore, its first appearance is in the pans. Solution accumulates in slime plants to an annoying degree at times, let alone taking in extra quantities. Using only barren solutions for the pans was tried for some time, but as mentioned above, a good deal of gold is dissolved in this department, and the graphite will do its work just the same.

To illustrate the different behavior of graphite and charcoal, I might mention that the ash-heap from the furnaces is being put through the mill at our plant. The ash is about equal parts of charcoal and dust, the latter from the hot-ore conveyor, hot air being taken here from the fire-box. During the roasting all the charcoal is burned out and no trouble is experienced. The waste acid from the clean-up is run through two large boxes of charcoal. When it gets rich enough, say 20 oz. per ton, it is dried, fed into the ball-mills, and mixed with the ore. It is completely burned in the roasters and causes no after effects.

The Oroya-Brownhill, working the same lode as the Associated Northern, treats its ore by wet crushing with stamps, concentration, pans, and tube-mills, agitation with BrCN, and filter-pressing. Ore containing graphite is occasionally sent to the mill, and soon thereafter the extraction and even precipitation falls off. The graphite forms a scum on the settlers, the circulating waters being a weak KCN solution. At the Associated the ore is treated by the ordinary dry-crushing and roasting process, and although a little graphite finds its way into the mill, little trouble has been experienced from this source. The graphite shown me at the Great Boulder mine is a pure graphitic schist, and is found on the walls of the lode in places. The ore is treated by ball-milling, and Griffin mills and roasting, and the graphite gives trouble by precipitating the gold. At the Lancefield there is both graphite and arsenic in the ore, and the treatment of these has not yet been determined.

A custom mill here, the Kalgoorlie Gold Recovery Co., buys sulphide ores, concentrate, slags, etc., treating these products by ball-milling, roasting, grinding, and filter-pressing, as the case may be. Now and again old crucibles and the like are mixed with the charges, and the graphite from these floats on the top of the thick slime in the cone agitators, agitation being effected by air at 10-lb. pressure. So far, the manager has not been able to see that bad results are caused by the graphite; but a strange thing was noticed, that, in filling five cones with the same class of slime, the graphite would only form a scum on one. We have noticed the same occurrence with the pulp in our pans.

The matter rests at that, and until some method is devised to deal with the graphite, the trouble can only be minimized by carefully excluding such ore from being sent to the mills.

(February 5, 1910)

The Editor:

Sir—Regarding 'Graphite—An Obstacle to Good Cyaniding', by M. W. von Bernewitz, in your issue of December 4, there is no doubt in my mind that graphite does interfere with the extraction of gold from refractory ores. In treating slags and crucibles (crushed in a ball-mill with cyanide) I have had no trouble. As far as my experience goes, graphite ores are 'refractory', and there seems to me to be some connection between the graphite and the re-

fractory effect. For instance, in the Ashanti Goldfields the current tailing when treated with 0.15% KCy solution gave a poor extraction, while accumulated tailing, after preliminary washing and alkaline treatment, gave good extraction. In both cases graphite was present in sufficient quantity to form a scum on the surface. This graphitic ore of the Ashanti Goldfields, which contains a greater percentage of graphite than does the Kalgoorlie ore, and like the latter occurs in schistose rocks, is now treated by dry crushing, roasting, and cyaniding, an extraction of over 90% being obtained.

The ore is put through a revolving dryer and crushed through a 25-mesh screen in No. 5 Krupp ball-mills. From them it is conveyed to an Edwards duplex furnace, and then to cooling bins by means of a push conveyor. The roasted ore is leveled and cooled, and dampened with water in these cooling bins, and is then trucked to cyanide tanks, where it is treated with 0.25% KCy solution.

There is no separation of sand from slime. Sintering is prevented by the careful manipulation of the air-inlets close to the end fire-grate, where is the greatest heat. If the ore should chance to form lumps, the complete removal of the air-inlets will soon cause the lumps to disappear. The test for a good roast is to take a little of the discharge, let it cool, put it in a glass beaker, add clear water, and if no graphite particles float on the top, the roast is good. The roasted discharge should be tested every half hour. This can be done by the fireman.

I do not agree with Mr. von Bernewitz that "the trouble can only be minimized by carefully excluding such ore from being sent to the mills." The plant at Ashanti Goldfields, Gold Coast Colony, has been treating graphitic ore (containing more graphite than the Kalgoorlie ore) successfully for the past three years, obtaining an extraction of over 90 per cent.

DONALD F. FOSTER.

Belmont, Sutton, England, December 21.

(June 11, 1910)

The Editor:

Sir—When I wrote the article 'Graphite—An Obstacle to Good Cyaniding', published in your issue of December 4, 1909, I was simply giving my experience with it, and the trouble that it gave in other mills here, not dealing with graphite ore in other parts of the world; and I still maintain that, "the trouble here can only be minimized by carefully excluding such ore from being sent to the mills," in spite of D. F. Foster's good results at Ashanti, as in his letter of your issue of February 5, 1910. I take it that, at Ashanti, the graphite is always present, whereas in Kalgoorlie, it only comes in occasionally, sometimes being easily detected, and often being so finely distributed that it is not noticed until it floats on the pans. Mr. Foster does not give the percentage of graphite in the Ashanti ore, but we have some that runs much higher than the 0.75% average in the analysis in my notes. Up to a certain point, the treat-

ment of the two ores mentioned is similar, beyond that it differs greatly. At Kalgoorlie all the roasted ore must be slimed for subsequent agitation with 0.08% KCN. Damping down the roasted product with water or KCN was tried here 11 years ago with disastrous results, as the lime and magnesia present in large amounts in the average ores milled were converted into sulphates during roasting, and on this being wetted, the ore set like cement in the percolation tank, the consumption of KCN being high and extraction as low as 65%. This will show that the Ashanti ore is much easier to deal with than the ore here. Regarding the roasting of an ore containing graphite, it seems to me to be excellent work to burn out this mineral by manipulating the air-inlets near the firebox, but this has been unsuccessful here so far, although all these things have been tried with the Merton, ordinary and improved, and the Edwards duplex type of furnaces. Roasting has reached a high state of efficiency at Kalgoorlie. The roast is tested for sulphur as sulphide by the iodine method, no special test being applied for graphite, as it is not always known when it is coming in. What happens at Ashanti when there is a poor roast, which happens in the best regulated furnaces at times? Is the extraction low? With regard to residue containing graphite and fair amounts of gold, I may say that many thousand tons of this have been successfully treated here, proving that exposure to the atmosphere changes the condition of the residue somewhat. As to extraction, in 1909 the average was 93%, often being as high as 95%, but the graphite at times lowered it to 90 per cent.

Only one mill here that employs the wet crushing, all-sliming treatment is bothered with graphite, the mine being on the eastern side of the belt where most of this mineral is encountered. Its effect in the cyanide treatment seems to be much worse than in the roasting plants. Graphite is a very stable mineral, and no doubt a little is burned in the furnace, but so far roasting has failed to eliminate all of it, and, as I said before, it only comes in occasionally, being one of those little troubles that is a nuisance for a day or two and then disappears for weeks. The Associated Northern Blocks and the Oroya-Brownhill group of mines, where much graphite has been met, are almost worked out. The Associated gets a little, and the Great Boulder also where a good deal has been encountered of late in the lower levels, 2500 feet.

It is rather an interesting subject, and at Ashanti the problem appears to have been solved by quite a simple method; and yet here we cannot get the usual high extractions when graphite is present. In the published returns from the Ashanti company, I had noticed that roasting was part of the treatment, and wondered what the ore was like. Through the medium of correspondence in your journal, I have been enlightened on this and other points.

M. W. VON BERNEWITZ.

Kalgoorlie, Western Australia, March 4.

TESTS ON ACID REGENERATION OF CYANIDE SOLUTIONS

By R. P. WHEELOCK

(December 18, 1909)

An opportunity was recently presented to make an investigation of the cyanide treatment at a certain plant with the object of decreasing the cyanide consumption. Because of limited time and facilities, exhaustive analyses were impossible, consequently the results obtained are not as conclusive as might be desired. The plant mentioned was designed primarily for the treatment, by leaching, of the coarser portion of a roughly sized accumulation of mill tailing. Though rated at 150 tons daily capacity, it has, under the most favorable conditions, an estimated daily capacity of 145 tons, allowing five days for total treatment. Its chief features are five 150-ton leaching vats (loaded and unloaded with the aid of belt-conveyors), from which the gold-bearing solution flows through one of two small distributing tanks to one or more of four 5-compartment zinc-boxes, thence to the storage sumps, where it is built up with cyanide as desired and returned to the leaching vats by means of a centrifugal pump.

It has been customary to pass from 300 to 500 tons of solution through each charge during its course of treatment, the amount being governed chiefly by the rate of percolation. Starting with a solution containing 5 lb. of KCy per ton, the strength is gradually decreased to 2 lb. in the succeeding solutions and this, on the last day, is followed by a wash of from 20 to 30 tons of water. A vacuum-pump assists in draining the vat. The tailing discharged contains about 20% moisture. Sodium cyanide is used exclusively, but all cyanide contents are noted in terms of 100% KCy. All titrations for free cyanide during these experiments, were made by Liebig's method, using silver nitrate and potassium iodide for an indicator, and titrations for protective alkali were made with a sulphuric acid solution and phenol phthalein after the addition of silver nitrate. For the sake of later brevity, I will also state that the results of titrations for free cyanide and protective alkalinity are given in pounds of potassium cyanide and calcium hydrate respectively per ton of solution.

At the time these investigations were undertaken, the cyanide consumption had increased to about 5 lb. KCy per ton of ore. Preliminary experiments, while not exhaustive as to the cyanicides present in the ore treated, had demonstrated that copper was the chief one and that its compounds soluble in cyanide solution were probably present in sufficient quantity to account for the loss of cyanide in treatment. After six months' operation of the plant, a number of determinations of the working solutions showed from 0.45 to 0.50% copper. Assays during the succeeding six months, and at the time when these tests were made, gave the same range. An average sample of the tailing being treated showed 0.61% copper. This copper occurs mainly as chrysocolla, malachite, and chalcocite. Lead is also present as galena, cerussite, and wulfenite.

Merely to satisfy curiosity, rough tests were made to determine the relative effects of these minerals upon a cyanide solution. A picked sample of each mineral was taken from the ore-bins and crushed to pass an 80-mesh screen. One hundred grams of each pulp-sample was treated with 250 c.c. of an 8.55-lb. KCy solution for 24 hours in a 300-c.c. bottle. The bottles were frequently shaken. While the manner of preparing the samples precluded the possibility of their being free from foreign cyanicides, yet the results seemed sufficiently marked to make them worthy of passing mention. The copper assays of each sample, and the cyanide titrations of the solutions at the end of 24 hours follow:

	KCy, lb.	Copper, %
Chrysocolla	0.033	35.90
Malachite	Trace	64.90*
Chalcocite	Trace	44.65
Galena	2.70	1.45
Cerussite	3.05	0.85
Wulfenite	8.30	Trace

*Probably mixed with some chalcocite.

Another sample of 100 gm. of malachite was taken and treated with 250 c.c. of water in which was dissolved 108.14 gm. KCy. After 12 hours, a consumption of 96.89 gm. KCy was indicated. Considerations which it is unnecessary to detail rendered it inexpedient to attempt the removal of the copper before cyanide treatment, and, to me, the most obvious alternative was the precipitation of the copper held in solution, and the liberation of its combined cyanide, if possible. It was known that upon the addition of acid to a cyanide solution containing double cyanides of the heavy metals with the alkali metals, most of the heavy metals are precipitated as cyanides. In the case of copper the reaction is probably,

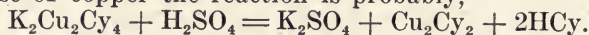

Julian and Smart, speaking of the dissociation of cyanogen, even by weak acids, state: "If, however, the acid is dilute, * * * the action (of acid upon cyanide) is similar to that which occurs with water, thus,



In very dilute solutions the HCy escapes into the air so slowly that even some hours after the solution became acid practically the whole of the HCy is still present, and if alkali is added it will be found that the solution has lost little of its original strength. Some HCyO and KCyO is also formed in the presence of dissolved air."

With these statements in mind, I first determined the approximate amount of acid required to produce as complete precipitation as possible, using for the purpose 500 c.c. of a representative sample of the cyanide sump-solutions containing 2.2 lb. KCy, 1.5 lb. Ca(OH)₂, and 0.48% Cu. To this was added, 1 c.c. at a time, a 50% solution of sulphuric acid. A heavy white precipitate was produced which settled rapidly, leaving a clear solution. At frequent intervals small filtered portions of the solution were tested with a drop of the dilute acid until 15 c.c. of the acid had been added

to the original 500 c.c. of KCy solution, when it was found that no further precipitate was produced. Five cubic centimetres of concentrated sulphuric acid were added to 250 c.c. of the working cyanide solution, which titrated 1.3 lb. KCy and 0.7 lb. Ca(OH)_2 . After allowing a few minutes for the precipitate to settle, 10 gm. CaO were added, and the mixture stirred. The presence of undissolved CaO rendered it impossible to tell whether the original precipitate was re-dissolved, or a further precipitate produced. A titration gave 0.1 lb. KCy and 6.7 lb. Ca(OH)_2 , the Ca(OH)_2 titration being of small value, however, on account of the indeterminate amount of lime in suspension. Later tests, in which sodium hydrate solution or lime-water were used instead of solid CaO, showed that the precipitate resulting from the addition of acid was re-dissolved, and a loss of free cyanide was shown in each case, undoubtedly due to the loss of HCy during the manipulation of the acidified solution. A 1000-c.c. sample was taken from the storage sumps. Titrations showed 1.4 lb. KCy and 0.7 lb. Ca(OH)_2 . To this were added 15 c.c. concentrated H_2SO_4 , and the solution agitated just sufficiently to secure a homogeneous mixture. This was immediately filtered into a beaker containing 200 c.c. of saturated lime-water. A titration showed 12.5 lb. KCy. Allowing for the increase in volume due to the addition of the lime-water, the result was 15 lb. KCy. A number of experiments on the same scale, using either solid CaO or limewater, confirmed this result, the titrations varying from 14.9 to 15.3 lb. KCy, after making necessary corrections for dilution.

It now seemed expedient to make a test upon a somewhat larger scale, and for the purpose an empty cyanide case, approximately 21 in. square and 12 in. deep, was secured. In this was placed 160 lb. of the working cyanide solution, containing 1.5 lb. KCy, and 1.5 lb. Ca(OH)_2 per ton, 0.46% copper, and a trace of gold. To this was added 2.5 lb. of commercial sulphuric acid. The usual heavy white precipitate was allowed to settle. Some gas was evolved, making it necessary to stir the top of the solution in order to facilitate the settlement of a portion of the precipitate which entangled gas-bubbles rendered buoyant. Otherwise the precipitate settled rapidly, and the resultant solution was quite clear. After one-half hour, the supernatant liquid was decanted into another cyanide case containing 7 lb. of commercial CaO, which was frequently stirred during the decantation. At the end of another half hour, a sample taken for titration showed 16.3 lb. KCy. After the lapse of three hours, titrations gave 15.6 lb. KCy and 2 lb. Ca(OH)_2 .

For the purpose of determining the permanency of the cyanide content, the solution was allowed to stand several days. After 24 hr. the result of a titration was 15.6 lb. KCy, and after 48 hr., 15.7 lb. KCy and 2 lb. Ca(OH)_2 . After having stood for 10 days another titration was made, and showed 20 lb. KCy, the increase in value being due to the fact that approximately one-quarter of the solution had evaporated. The precipitate from this test was collected, dried, weighed, as a check upon the precipitation of the copper. The drying being conducted rather crudely, resulted in the decom-

position of a small portion of the precipitate; consequently the assays are of no value for the determination of its percentage composition, though they serve for the check mentioned. The weight, as dried, was 1 lb., and the assays were, gold, 0.09 oz. per ton; silver, 0.21 oz.; copper, 68.15%. In the original, 160 lb. of solution at 0.46 copper, there was 0.736 lb. of copper. The precipitate at 68.15% contained 0.6815 lb. copper, and the resultant regenerated solution 0.029%, or 0.0464 lb., a total of 0.728 lb. The copper in the regenerated solution was probably due to the re-dissolution of a small portion of the precipitate which passed into the lime receptacle during the process of decantation.

To determine the dissolving power of the regenerated solution, a test was made upon a sample of tailing. Four bell-jars were

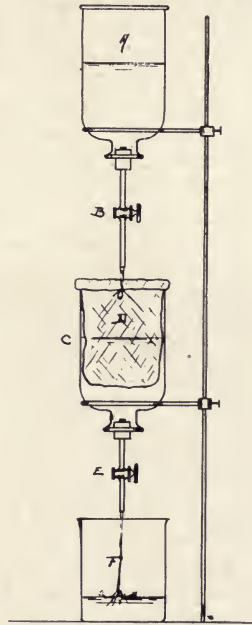

Fig. 73

made to serve as shown in Fig. 73, which illustrates one of the two units of the apparatus employed. *A* is an inverted bell-jar to hold solution, fitted with a glass-tube and stop-cock *B*, which regulates the flow of solution into the bell-jar *C*. The latter contains a canvas bag *D* for holding the pulp under treatment, and to serve as a filter. *E* is a glass-tube and stop-cock for regulating the flow of solution from the jar *C*. *F* is a beaker to catch the solution. The solution collected in this beaker was poured back into jar *A* as desired. Of the tailing, two 5-lb. samples were taken. Lime was mixed with each sample in the proportion of 9 lb. per ton of ore, which was the amount regularly used in the large leaching vats. The samples,

No. 1 and 2, were placed in bags *D* and *D'* respectively. Sample No. 1 was treated with a regenerated solution titrating 15.6 lb. KCy, but diluted with water to 5.05 lb., with 0.5 lb. Ca(OH)₂. Sample No. 2 was treated with a portion of the working solution titrating 1.6 lb. KCy, but built up with cyanide to 5 lb., having 1.4 lb. Ca(OH)₂: 2000 c.c. of solution were used in each case. The rate of flow was so regulated that this amount leached through the pulp about once every four hours. The subsequent titrations of samples of the two solutions are given below.

	—Solution No. 1—		—Solution No. 2—	
	KCy, lb. per ton.	Ca(OH) ₂ , lb. per ton.	KCy, lb. per ton.	Ca(OH) ₂ , lb. per ton.
At start	5.05	0.50	5.00	1.40
After 16 hours.....	3.35	4.50
After 25 hours.....	2.35	0.25	3.20	0.25
After 40 hours.....	1.70	0.20	2.25	0.20
After 45 hours.....	1.20	0.20	2.00	0.15

After 45 hr., the solution was drained off and each sample was treated with 2000 c.c. of wash-water, which titrated KCy and Ca(OH)₂ respectively for solution No. 1, 0.125 and 0.025, and for No. 2, 0.325 and 0.037 lb. per ton.

The gold and copper assays tabulated are as follows:

Sample.	Before treatment.		After treatment.	
	Gold, oz.	Copper, %	Gold, oz.	Copper, %
Heads of test.....	0.13	0.6580
Tailing No. 1.....	0.040	0.6270
Tailing No. 2.....	0.040	0.6420
Solution No. 1.....	Trace	0.0223	0.073	0.0573
Solution No. 2.....	Trace	0.4640	0.057	0.4820
Wash No. 1.....	0.020
Wash No. 2.....	0.026

It was thought that possibly the alkalinity of the solution used might have some bearing on the extraction and consumption of cyanide, consequently an attempt was made to secure appropriate data. A sample of tailing was secured which assayed 0.246 oz. gold per ton, 0.894 oz. silver, and 0.768% copper. The sample contained 11% moisture, but all assays are based upon the dry weight. Three portions, No. 1, 2, and 3, of 5 lb. each, undried weight, were taken, and to each portion was added 11.34 gm. CaO, equivalent to 10 lb. per ton. Three units of the leaching apparatus described in connection with the previous experiment were used, and samples No. 1, 2, and 3 were placed in jars *C*, *C'*, *C''*, respectively. Three solutions, No. 1, 2, and 3, were prepared.

Solution No. 1 consisted of regenerated cyanide solution at 19.2 lb. KCy. This was diluted to 4.5 lb. KCy, with 0.4 lb. Ca(OH)₂. The alkalinity was reduced by using H₂SO₄. Solution No. 2 was a portion of solution No. 1, diluted, with the alkalinity increased by the addition of CaO. Solution No. 3 was regular stock-solution, titrating 1.5 lb. KCy and 1.1 lb. Ca(OH)₂, built up with KCy and CaO. The final titrations and assays on the three foregoing solutions were:

	KCy, lb. per ton.	Ca(OH) ₂ , lb. per ton.	Gold, oz. per ton	Copper, %
No. 1.....	4.35	0.1	Trace	0.0107
No. 2.....	4.55	4.0	Trace	0.0107
No. 3.....	4.85	1.9	0.016	0.3280

Samples No. 1, 2, and 3 were treated with 2000 c.c. each of solutions No. 1, 2, and 3, respectively, as in the previous test. The record of titrations and assays is as follows. After 4 hr., the solutions having leached through the pulp once:

	KCy, lb. per ton.	Ca(OH) ₂ , lb. per ton.
No. 1.....	2.00	1.0
No. 2.....	2.90	1.3
No. 3.....	3.85	1.9

After 17 hr., the solution having leached through twice:

	KCy, lb. per ton.	Ca(OH) ₂ , lb. per ton.
No. 1.....	1.3	1.0
No. 2.....	1.6	0.7
No. 3.....	2.6	1.3

At this point $1\frac{1}{4}$ lb. of the pulp was taken from each jar for assay, and a sample was also taken from each solution, sufficient to preserve the original ratio between the pulp and solution. The assays were as follows:

	Pulp			Solution	
	Gold, oz.	Silver, oz.	Copper, %	Gold, oz.	Copper, %
No. 1.....	0.130	0.710	0.689	0.143	0.0555
No. 2.....	0.100	0.720	0.627	0.133	0.0588
No. 3.....	0.135	0.785	0.627	0.093	0.3478

The treatment was continued with the remainder of the pulp solution. After 24 hr., the solution having leached through three times, the titrations were as follows:

	KCy, lb. per ton.	Ca(OH) ₂ , lb. per ton.
No. 1.....	1.0	0.90
No. 2.....	1.5	0.75
No. 3.....	2.2	1.30

After 41 hr., the solution having leached through four times:

	KCy, lb. per ton.	Ca(OH) ₂ , lb. per ton.
No. 1.....	0.60	1.00
No. 2.....	1.25	0.75
No. 3.....	1.55	1.20

Solution assays at this point were:

	Gold, oz.	Copper, %
No. 1.....	0.223	0.0630
No. 2.....	0.153	0.0672
No. 3.....	0.123	0.3783

The solution was drawn off and the pulp allowed to drain. Each

sample was then washed with 1500 c.c. of water. Titrations and assays of wash-water were:

	KCy, lb. per ton.	Ca(OH) ₂ , lb. per ton.	Gold, oz.
No. 1	0.20	0.70	0.070
No. 2	0.25	0.25	0.063
No. 3	0.45	0.45	0.053

The assays of the pulp-tailing of this test were:

	Gold, oz.	Silver, oz.	Copper, %
No. 1	0.120	0.700	0.611
No. 2	0.115	0.685	0.595
No. 3	0.150	0.780	0.689

It was now decided to make a regeneration test upon a scale more nearly approaching that which would be required for the practical application of the method; consequently two tanks were arranged as shown in Fig. 74. Tank A had 17 tons capacity, and

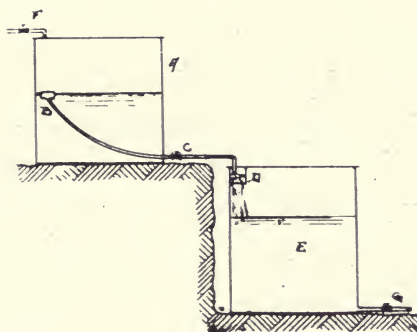

Fig. 74

tank E 25. Three successive charges of solution were treated. For the first, 7.63 tons of old KCy solution was pumped into tank A at 1.9 lb. KCy, into 1.45 lb. Ca(OH)₂, assaying 0.02 oz. gold and 0.48% copper. Into this was stirred 202 lb. of commercial sulphuric acid. After the addition of the acid, two hours were allowed for the settlement of the precipitate, the top of the solution being stirred occasionally to facilitate the settling process. The solution was then decanted by means of the float-valve B through the box D into tank E. Lime was added to box D from time to time until the amount so added aggregated 190 lb. A titration of the regenerated solution showed 8 lb. KCy and 0.75 lb. Ca(OH)₂. It was found difficult to keep the decanted solution alkaline, the frequent addition of fresh lime to box D, and constant stirring, being necessary. A small sample taken from tank A before decantation, and made alkaline, gave 15.6 lb. KCy. A disagreeable odor was given off during the action of the acid on the cyanide solution, and the odor of HCN seemed to be distinguishable. The escaping gas had a tendency to produce headache. It was thought that considerable of the HCN must have

escaped during decantation on account of the difference between the strength of the final regenerated solution (8 lb. KCy) and the strength obtained from the small test-sample (15.6 lb. KCy); consequently, for the second charge, the piping was changed slightly, a third tank was added, and a centrifugal pump was connected to

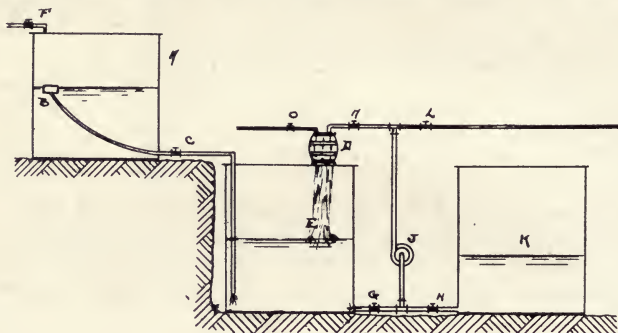

Fig. 75

the system as shown in the diagram, Fig. 75; 16 tons of old solution, titrating 1.65 lb. KCy and 1.65 lb. $\text{Ca}(\text{OH})_2$, and assaying 0.033 oz. gold and 0.48% copper was pumped into tank A. To this was added 498 lb. of commercial sulphuric acid. A small sample was taken after the addition of the acid. This was made alkaline with lime and titrated 15.8 lb. KCy. While the precipitate was settling, lime was added to the barrel D, and by means of the centrifugal pump the solution in the tank E, from the previous charge, was circulated through the barrel D until it was thoroughly saturated with lime. The solution from tank A was decanted into tank E. It will be noted that the discharge pipe from A was extended below the surface of the solution in E to prevent, so far as possible, the aeration of the acidified solution. During the decantation, water was run through the barrel D, to which lime was continually added. A total of $8\frac{1}{2}$ tons of water, and 325 lb. of lime was used. As tank E became full, part of the solution was allowed to flow into tank K. The final product from the two charges was 13 tons at 9.2 lb. KCy in tank K, 16 tons at 7 lb. KCy in tank E, and 3 tons not decanted from tank A.

13 tons at 9.2 lb. KCy	119.60
16 tons at 7.0 lb. KCy	112.00
	<hr/>
	231.60
Less first charge, 7.63 tons at 8.0 lb. KCy	61.04
	<hr/>
13 tons from second charge	170.56

This equals 13.12 lb. KCy per ton treated. After about 16 hr., the balance of the solution in tank A was decanted into a solution of lime and a titration gave only 2.5 lb. KCy, after allowance had been made for the dilution. There had evidently been a considerable evolution of HCl from the acidified solution.

For the third charge, the arrangement of the apparatus used was the same as for the second charge. However, about three tons of the regenerated solution from the first two charges was left in tank *E*. Into this two tons of water was passed through barrel *D*, to which lime had been added. The result was five tons of a strong lime solution which titrated 6 lb. KCy. Fifteen tons of old cyanide solution titrating 1.65 lb. KCy and 1.65 lb. Ca(OH)₂ was pumped into tank *A*. This was treated with 418 lb. of commercial sulphuric acid. After settlement of the precipitate, 12 tons of the acidified solution was decanted into tank *E*. During the decantation, the solution in tank *E* was circulated through barrel *D*, into which fresh lime was frequently placed. The amount of lime added to this charge was 455 lb. A titration of the resultant solution gave 12.2 lb. KCy. Accounting for the dilution by the five tons at 6 lb. KCy, the 12 tons decanted from the acid tank, if undiluted, should have titrated 14.8 lb. KCy. It was now deemed advisable to test the dissolving power of the regenerated solution upon a working scale. One hundred and forty-five tons of tailing was charged into one of the regular leaching vats. The assay was 0.225 oz. gold per ton. During the charging, lime was mixed with the pulp to the amount of 9 lb. per ton.

There follows a record of the treatment of the tank for three days: First day, 9:45 a.m., pumped on 11 tons solution with 7 lb. KCy per ton, and 11 tons at 9.8 lb. KCy. In this solution I failed to secure the proper neutralization with the lime, consequently, after the addition of sufficient silver nitrate to combine with the free cyanide present, the solution did not show an alkaline reaction with phenolphthalein.

At 4:45 p.m., pumped on 10 tons of 9.8 lb. KCy and 12 tons of 11.7 lb. KCy solution; both of these had 0.2 lb. Ca(OH)₂. The solution was allowed to stand in contact with the pulp until 7 a.m. of the next day. On the second day, 7 a.m., started leaching at the rate of about two tons per hour. The solution was allowed to flow through one 5-compartment zinc-box into a storage-sump. The titrations and assays of samples taken at different times during the day are as follows:

		KCy, lb. per ton.	Ca(OH) ₂ , lb. per ton.	Gold, oz.	Copper, %
Vat	7:30 a.m.	0.2	1.3	0.17	0.1440
	9:30 a.m.	0.3
	10:30 a.m.	Trace	1.2	0.21	0.1442
	1:30 p.m.	0.05	1.5	0.21	0.1485
	4:30 p.m.	0.05	1.5	0.20	0.1461
Sump	7:30 a.m.	0.003
	4:30 p.m.	0.007

A boring sample of the vat, taken at 3:30 p.m., gave: sample unwashed, 0.11 oz. gold; sample washed with three charges of water, 0.09 oz. gold. A sample of the solution taken at 1:30 p.m. was regenerated in the laboratory with sulphuric acid and lime, and gave 4.4 lb. KCy. An assay of this regenerated solution showed a trace of gold, and 0.0047% copper.

Lack of sulphuric acid prevented the further treatment of this

vat with regenerated solution; consequently at 4:30 p.m., 17 tons of solution from the storage sump, consisting of the solution previously used, and sufficient unused regenerated solution to give a strength of 3.3 lb. KCy and 1.6 lb. $\text{Ca}(\text{OH})_2$ were pumped on the vat. This was allowed to leach slowly all night. At 7:30 the following morning the solution draining from the vat showed 0.05 lb. KCy and 1.8 lb. $\text{Ca}(\text{OH})_2$, 0.25 oz. gold, and 0.2069% copper.

In an attempt to verify the suspicion that the HCy was rapidly lost upon exposure of the acidified solution, the following table was constructed:

1	2	3	4	5	6
		Immediate titration, lb. per ton.	Filtered, lb. per ton.	Unfiltered, lb. per ton.	On acid, lb. per ton.
Nitric Acid.	Lime.....	9.2	20.5	18.5	0.3
	NaOH.....	17.7	17.7	18.3	0.3
Hydrochloric	Lime.....	17.5	...	19.8	3.6
	NaOH.....	18.4	19.4	19.9	3.4
Sulphuric	Lime.....	15.6	17.6	16.2	0.5
	NaOH.....	13.3	14.6	16.2	0.5

Nitric, hydrochloric, and sulphuric acid was each used in turn as a precipitant, and with the acid, CaO and NaOH were employed to render the acidified solution alkaline, the acidified solution being allowed to filter into a beaker containing 50 gm. CaO or 5 gm. NaOH. The figures in the table represent KCy expressed in pounds per ton of solution. Column 1 shows the acid used. In each case 200 c.c. cyanide solution was treated with 5 c.c. acid. Column 2 shows the alkali used. Column 3 the acid precipitate, immediately filtered off with the least possible manipulation and agitation, the filtrate made alkaline, again filtered, and the second filtrate titrated. Column 4, the acid precipitate, immediately filtered off, the filtrate rendered alkaline, and after being filtered again allowed to stand 12 hr. before being titrated. Column 5, the acid precipitate, filtered off immediately and the filtrate rendered alkaline; the alkaline solution allowed to stand without a second filtering for 12 hr., and then filtered and titrated. Column 6, the unfiltered acidified solution, allowed to stand 12 hr. before the addition of the alkali, then rendered alkaline, filtered, and titrated.

Several tests were made with the precipitate obtained from the acid treatment, substantially as follows: the apparatus used was arranged as shown in Fig. 76. Twenty-five grams of the dried precipitate was placed in flask *A*. To this was added 50 c.c. water and 50 c.c. concentrated HCl. A cork was placed in the flask with tubing *B* leading to beaker *C*. In beaker *C* was placed 250 c.c. water in which was dissolved 10 gm. NaOH. The content of flask *A* was then heated to boiling. Titrations of the NaOH solution in beaker *C* were as shown in the table following.

	KCy, lb. per ton.
At start
After ½ hour	5.70
After 1 hour	78.75

The beaker was then removed, and after standing for 18 hr. a titration gave 79 lb. KCy.

In the foregoing notes, while copper, on account of its predominance, has been considered to the exclusion of other base

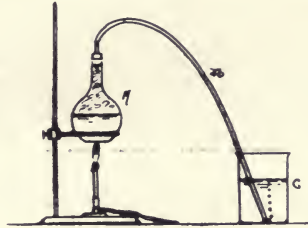
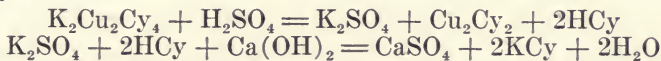

Fig. 76

metals, it is appreciated that there are others present in the solutions treated, notably zinc and lead. If the reactions in the case of copper are



for every pound of copper present there should be recovered 1.03 lb. KCy, consequently for a solution containing 0.5% copper, or 10 lb. per ton, there should be a recovery of 10.3 lb. Titrations of the regenerated solutions, however, frequently showed between 14 and 15 lb. in excess of the strength before treatment, during which it is probable that there were some losses. If one attempt to check the data given, there will be noticed a number of discrepancies, which probably are largely chargeable to experimental error, due to the crudity of the methods and apparatus employed and to failure to appreciate fully all the conditions governing the phenomena observed, yet the results seem to be sufficiently marked, and those of similar tests sufficiently in accord, to justify the conclusion that the process is feasible, and under proper conditions might be commercially profitable. Upon this point, criticism by those interested is desired.

Considering the last of the three tests with the apparatus shown in Fig. 75, the 15 tons of solution treated titrated originally 1.65 lb. KCy, and subsequently (with correction for dilution) 14.8 lb., a net gain of 12.15 per ton, amounting to 182.25 lb. of potassium cyanide, or 143.5 lb. of 127% sodium cyanide for the 15 tons. At 26c. per pound, this would be worth \$37.31. To recover this amount of cyanide, there was used 418 lb. of sulphuric acid at 3.5c. and 455 lb. of lime at 0.6c., a total of \$17.36. These figures show a profit of \$19.95, with no allowance for labor. As the whole operation required the services of but one attendant for a portion of a 3-hr. period, the labor cost was nominal. I also believe that the amount of acid and lime might have been reduced. In addition, there is the precipitate containing cuprous cyanide and probably cyanides of the other metals present in the solution. If the reactions given

for copper, and similar reactions for the other cyanides hold good, the precipitate should contain an amount of cyanogen equal to that already released. It is possible to recover a large portion of this, at least, as shown by the last experiment described, though to determine the commercial practicability of the operation would require further investigation. The solutions best adapted to acid regeneration are those low in free cyanide and alkalinity, the precipitation of the dissolved metals as cyanides not commencing until after sufficient acid has been added to neutralize the solution.

REGENERATING COPPER CYANIDE SOLUTION

(February 5, 1910)

The Editor:

Sir—I read with interest R. P. Wheelock's tests on the regeneration of copper cyanide solution, and I beg to say that I have made thousands of tests relative to the same, years ago. I had my method protected by patent, a part of which is controlled by a company. In fact, two patents were taken out. My experiments were practically all made with potassium cyanide, and not with sodium cyanide. I claim that it is commercially feasible, although the books contradict it. In handling a cyanide solution, if one cannot readily save the precious metals on zinc shaving, he can save the gold, silver, and copper with sulphuric acid, and will get the same results day after day if the acid is not used in excess, as Mr. Wheelock evidently did when the gas raised his precipitate to the surface, and caused the hydrocyanic-acid gas to escape. The solution should be agitated a second time after standing 15 to 20 minutes. Also a saturated solution will precipitate quicker than a weak one, and readily restore 80% or more of the potassium or sodium cyanide, as the case may be, at a cost of not to exceed 10c. per pound. The solution should be thoroughly saturated with copper, when that salt is present, before making the precipitation. The clear solution should be decanted, and the precipitate washed into the filter, before adding the second cyanide solution to be precipitated.

ISAAC ANDERSON.

Prescott, Arizona. December 20.

(March 12, 1910)

The Editor:

Sir—In his communication, in your issue of February 5, Isaac Anderson, commenting upon my experiments with acid regeneration of cyanide solutions, says that one "will get the same results day after day if the acid is not used in excess," and adds that I evidently used an excess of acid; apparently basing his assumption upon my statement that the hydrocyanic acid evolved raised a part of the precipitated simple cyanides to the surface of the solution. I assume, of course, that, by 'excess', Mr. Anderson means any

TABLE SHOWING REGENERATIVE EFFECTS OF VARYING AMOUNTS OF SULPHURIC ACID UPON CYANIDE SOLUTION CARRYING K_2Cu_2Cy , AND MINOR QUANTITIES OF OTHER DOUBLE CYANIDES.

No.	A.	B.	C.	D.	E.	F.	G.
1	0.0	2.8	3.0		
2	0.1	2.8	2.92	2.26	2.56	Slightly turbid.	Very light pp.; probably $CaSO_4$; slightly turbid.
3	0.2	2.4	2.92	2.28	2.4	Slightly turbid.	Very light pp.; probably $CaSO_4$; slightly turbid.
4	0.4	0.66	2.92	2.20	2.5	Turbid.	Small amount of fine-grained pp.; slightly turbid.
5	0.6*	0.60	2.92	1.84	2.36	More turbid.	Small amount of fine-grained pp.; slightly turbid.
6	1	0.40	2.88	0.62	1.4	Still more turbid.	Small amount of fine-grained pp.; slightly turbid.
7	2†	...	2.70	...	0.14	Small amount pp.	Small amount pp. solution, clearer than preceding.
8	3	...	6.76	...	0.14	Considerable fine pp.; some on surface of solution.	Small amount pp.; slightly flocculent; clear solution.
9	4	...	7.75	...	1.60	More flocculent pp.; some on surface of solution.	Flocculent pp.; little on surface; clear solution.
10	4.5	...	8.85	...	1.92	Flocculent pp.; some on surface of solution.	Flocculent pp.; some on surface; clear solution.
11	5‡	...	10.4	...	2.0	Flocculent pp.; more on surface of solution.	Flocculent pp.; some on surface; clear solution.
12	6	...	10.0	...	3.72	Flocculent pp.; more on surface of solution.	Flocculent pp.; more on surface; clear solution.
13	7	...	9.7	...	2.18	Flocculent pp.; more on surface of solution.	Flocculent pp.; more on surface; clear solution.
14	8	...	9.95	...	2.24	Flocculent pp.; more on surface of solution.	Flocculent pp.; more on surface; clear solution.
15	10	...	9.3	...	2.58	Flocculent pp.; more on surface of solution.	Flocculent pp.; more on surface; clear solution.
16	15	...	8.9	...	1.74	Flocculent pp.; more on surface of solution.	Flocculent pp.; still more on surface; clear solution.
17	20	...	8.9	...	2.2	Flocculent pp.; still more on surface of solution.	Flocculent pp.; still more on surface; clear solution.
18	30	...	8.6	...	2.4	Pp. very coarse and flocculent; much on surface.	Coarsely flocculent pp.; surface covered; clear solution.
19	50	...	8.8	...	2.78	Coarsely flocculent pp.; surface covered.	Coarsely flocculent pp.; about $\frac{1}{2}$ on surface; clear solution.

Column A. Amount of acid in c.c. per litre of cyanide solution; H_2SO_4 , sp. gr. 1.84 used.
 Column B. Titration with $AgNO_3$. Pounds KCN per ton solution. Titrated immediately after adding acid.
 Column C. Titration with $AgNO_3$. NaOH added to render solution alkaline.
 Column D. Titration. Acidified solution allowed to stand 12 hours. Titrated without adding NaOH.
 Column E. Titration. Acidified solution allowed to stand 12 hours. Titrated after addition of NaOH.
 Column F. Remarks on physical appearance of column B solutions.
 Column G. Remarks on physical appearance of column D solutions.
 Columns B and D. Solutions filtered before titrating.
 Columns C and E. Acid precipitate filtered from solution before addition of NaOH. Alkaline solution again filtered before titration.
 *Solution acid after titration. †Solution acid before titration. ‡Solution acid before titration. †5 c.c. per litre to effect complete precipitation.

amount of acid above that required to effect complete precipitation. The context, in his communication, preceding the statement quoted above leads me to believe also that the 'same results' refers rather to the recovery of the dissolved metals than to the regeneration of the cyanide content of the solution, the latter being the chief result desired from the tests which I made.

I did use an excess of acid, although it was comparatively slight, because my approximate methods of determining the essential proportions of acid and solution, and of measuring them, necessitated by the conditions under which I was working, did not permit of great accuracy, and, furthermore, my experiments seemed to show that, while the addition of the proper amount of acid required to effect complete precipitation produced the best net results, when cost and regenerative effect were both considered, an excess gave results nearer the maximum than could be secured with a corresponding insufficiency of acid. In fact, the chief disadvantage of an excess seemed to be the cost of the additional acid and lime, or of caustic soda, required.

Furthermore, in regard to the escape of hydrocyanic acid and the consequent rise of a part of the precipitate to the surface of the solution as an index to the presence of an excess of acid, it appeared to me that some hydrocyanic acid was given off before the precipitation was complete, and this does not seem to be contrary to theory if the chemical reactions which take place are similar to

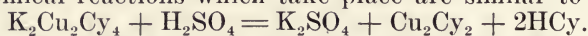

To obtain some further evidence upon this point, as well as upon the relative effects of insufficiency and excess of acid upon the regeneration of the cyanide content of the solution, I have made a few additional tests, the results of which are set forth in the accompanying table. I found that the same results were obtained day after day in so far as the freedom of the resultant solution from dissolved metals was concerned, but, of course, the amount of cyanide and precipitate recovered naturally depended upon the amount of double cyanides in solution. At the plant where my experiments were made, a limited sump-capacity prevented the manipulation of the solution so as to obtain the possible maximum content of soluble double cyanides in the solution to be regenerated. The addition of wash-water, precipitation of copper in the zinc boxes, and loss of copper-bearing solution with the discharged tailing, seemed to keep the copper-content of the working solutions at 0.5%, or slightly less. A freshly regenerated solution, upon being used, would quickly take up copper to the amount of about 0.25%. The percentage of copper, with further use of the solution, would increase more slowly until the apparent normal balance of about 0.50% was reached. This was the approximate copper-content of the solutions used in my experiments. Just what relation this percentage bears to a saturated solution I do not know. Mr. Anderson states that 80% or more of the potassium or sodium cyanide, as the case may be, can be restored in a saturated solution, and the wording of his sentence seems to warrant the inference that he means that this result can be obtained

by precipitation alone. If, as seems to be the concensus of opinion, the reaction for copper is approximately as above, and similar for other common metals, a recovery of but 50% of the cyanogen of the dissolved double cyanides is theoretically possible by precipitation alone. My experiments showed, however, that the recovery of a large proportion of the remaining 50% was possible by subsequent treatment of the precipitate. I trust that Mr. Anderson will not take offense at my criticisms, as the impelling motive for this communication is merely to gain information.

R. P. WHEELOCK.

Searchlight, Nevada, February 22.

(May 28, 1910)

The Editor:

Sir—In reply to R. P. Wheelock's statement in your issue of March 12, I beg to acknowledge an error in my explanation of February 5. The same result is obtained in restored cyanide, 80% or better, even if an excess of acid were used. I meant that the acid solution should be neutralized with lime before titrating for KCy. What I meant by saturated solution was solution enriched as much as possible with Au + Ag + Cu values before precipitation. By going to excess with acid and causing precipitation, the chemicals will float all the coagulated precipitates to the surface of the solution. These precipitates will remain there if the gas be not expelled. I do not mean, however, to say that the potassium cyanide cannot be restored even if an excess of acid has been added. To cause complete precipitation as Mr. Wheelock did, a small proportion of the solution being taken and filtered and acid added to the filtered solution, it is evident that enough has been used if it does not turn turbid.

Some contend that $\frac{3}{10}$ of 1% of copper sulphate is fatal to a working KCy solution. On that point the following test is instructive: take 1000 c.c. H_2O , add 5 gm. KCy + 10 gm. copper sulphate; slack and grind CaO to 60-mesh, add to convert the K_2SCuCy solution from green to blue. Before the copper sulphate is added to the KCy solution add a known amount of gold, say, at the rate of \$20 per ton. Take one assay ton of the filtered solution from the blue; precipitate the Au and Cu; restore with $Ca(OH)_2$; and note the saving of copper and gold and also the restoration of KCy. Filter off a portion of the $CuCy$ solution before $Ca(OH)_2$ is added and read the content for copper volumetrically; repeat this with the filtered solution after $Ca(OH)_2$ is added and note the results. Test the KCy restored solution for active service by agitating with gold leaf or pulp. A 5-lb. KCy solution, restored or fresh, should dissolve leaf-gold in four minutes when well agitated.

A sulphur-bearing KCy solution can be made that cannot be read with silver nitrate but is still active toward gold, silver, and copper; it may be regenerated. The sulphur can be liberated so that it can be read with $AgNO_3$ by precipitating the sulphur with copper or silver, thrown in solution and precipitated with H_2SO_4 . I

claim all solutions should be properly treated with lime before precipitation by either the acid or the zinc method. When Cu is present in the working solution my experience is that lime is not added in excess if carbonate of lime does not predominate on the surface of the solution like thin ice after standing six hours or over night on pulp.

In one case I have used 40 lb. of lime to one ton of ore. I did not simply use it to neutralize acid, as we were taught a few years ago, but to take care of the iron, zinc, and other salts as well. A pulp practically alkaline may take 10 lb. of lime. When copper is in solution and is being precipitated on zinc shavings, they are gray or brassy looking. If more lime be added they will change to black and will feel silky.

Referring to Mr. Wheelock's copper-acid-cyanide precipitate, my experience has been that such precipitate from a working solution consists of 40% copper, the balance being sulphur, lime, gold, silver, and a small percentage of cyanates.

I will later send data explaining a case where it takes 26 days to enrich a solution in its gold, silver, and copper content, a method applicable to decanting or percolating. Some of Mr. Wheelock's methods I would like to test, but have not the materials at hand. I have never enriched the solution pound for pound in copper, nor have I ever obtained a precipitate containing 50% cyanogen. It cannot be done if the solution or pulp has been properly treated with lime. Whenever the KCy is broken up by adding H_2SO_4 either in small quantity or in excess, it can be restored by calcium hydrate, but one cannot break up the KCy by adding copper sulphate if the proper amount of lime is present. The KCy will not pick up any more copper, gold, and silver than it will precipitate, or, in other words, it will precipitate all it picks up or a fraction thereof by adding H_2SO_4 . The lime protects the potash and allows restoration of 80% or better.

ISAAC ANDERSON.

Prescott, Arizona, March 31.

PRESSURE FILTRATION

By ERNEST J. SWEETLAND

(December 25, 1909)

I have recently made many experiments upon slime filtration to determine the relative rates of filtration at different pressures. The object of these tests was to study the practical side of the problem rather than the theoretical; to obtain information for application in every-day practice rather than to gather data of a highly scientific nature. For present purposes a detailed description of the filter which was used in these experiments is not called for, since like results may be obtained with any pressure-filter wherein filter-leaves or mats of any practical construction are enclosed within a chamber, and the sludge to be filtered is applied to their surface under pressure.

The results herein recorded were obtained in a Sweetland filter-press of 456 sq. ft. of filter-area, with slime which I obtained through the courtesy of the Goldfield Consolidated Mines Co. from the new Consolidated mill, this slime being selected because it was produced by modern crushing and re-grinding methods. During these tests about eight tons of slime was in circulation at the testing plant, and arrangements were made to return the slime to the agitator after each test, so that exactly the same slime could be used in each succeeding test, and thus avoid the possibility of false comparisons by a change in the character of the product under treatment.

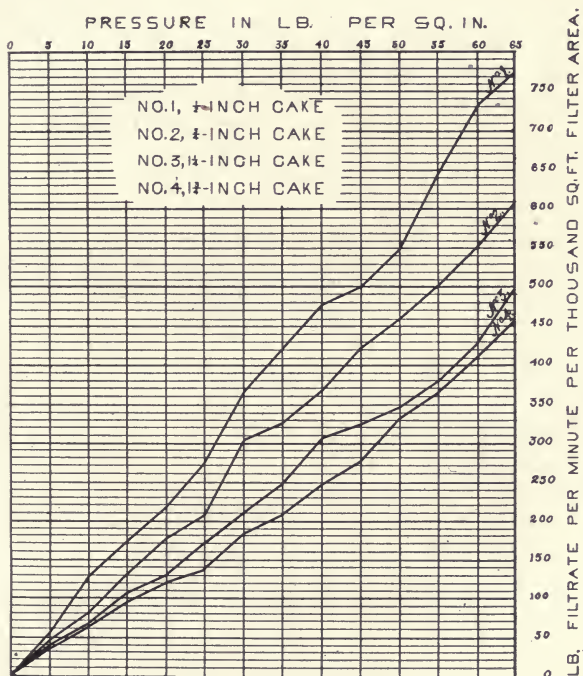

Fig. 77. RESISTANCE TO FILTRATION OF CAKES OF DIFFERENT THICKNESSES AT VARYING PRESSURES

Much has been said regarding the even permeability of slime-cakes formed upon submerged filter-leaves, the theory of which applies alike to enclosed leaves in pressure-filters, and to leaves submerged in an open tank, as in vacuum-filters. If a properly constructed leaf be submerged in a solution carrying solid matter in suspension, and a difference in pressure be created between the outer and inner walls of the leaf by applying suction within the leaf or pressure to its outer surface, filtration will progress, and the cake formed upon the surface of the leaf will be of even permeability throughout, regardless of structure or thickness; for the instant

there occurs any point of decreased density, there immediately takes place an increase in the rate of filtration at that point until sufficient slime has been deposited to make the resistance offered equal to that at other points. Modern methods of filtration owe their success largely to this phenomenon, for upon the even permeability of slime-cakes depends the success of displacing dissolved metals. The following experiment offers a splendid example of this automatic distribution of slime to form cakes of uniform density: Three

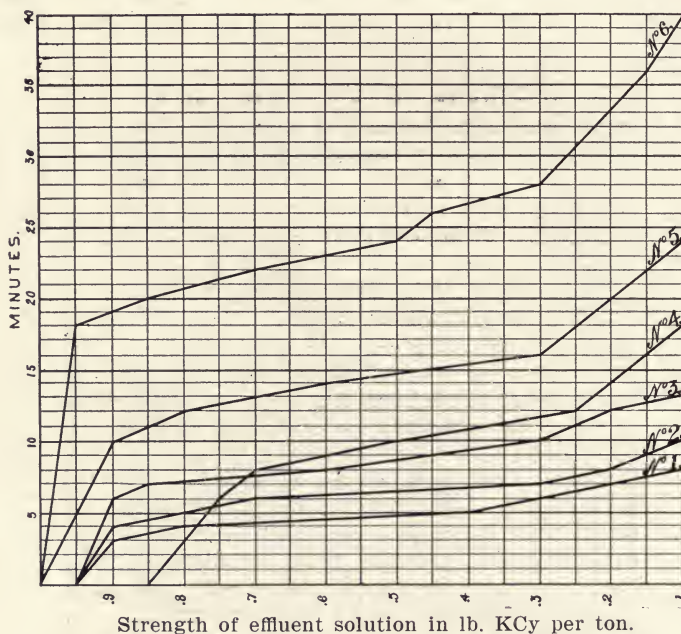

Fig. 78. TIME REQUIRED FOR WASHING CAKES AT DIFFERENT PRESSURE. NO. 1, 60-LB. PRESSURE; NO. 2, 50; NO. 3, 40; NO. 4, 30; NO. 5, 20; NO. 6, 10.

leaves of equal area, but of slightly different construction, were placed in the filter, and the filtrate from these was cut out from the general flow and conducted to three separate measuring receptacles, the remaining leaves being left intact to filter as usual. The filter-chamber was filled with sludge, and cake-forming commenced. During the progress of cake-forming three sets of measurements were simultaneously taken from the three leaves, with the following results:

Time.	No. 1. Filtrate per minute. lb.	No. 2. Filtrate per minute. lb.	No. 3. Filtrate per minute lb.
9:55	21.12	16.70	21.12
10:00	12.10	12.02	12.52
10:10	9.76	9.76	9.76

Note that in the first measurements all flowed at different rates, and in the second the rates were more nearly equal, while in the third all flowed at exactly the same rate.

My experiments have led me to believe that the point of greatest resistance to the flow of solutions through a slime-cake is at the point of contact between the slime-cake and the filtering medium, and that to double the thickness of a slime-cake does not double its resistance to the passage of solutions. When canvas is used as the filtering medium the pores are instantly partly clogged when filtration commences, and when the fine pores of the canvas are filled with minute particles of slime a medium is formed of greater resistance than the slime itself. Fig. 77 shows the comparative resistance of cakes of different thicknesses to the passage of solutions at pressures from 0 to 60 lb. per square inch. It will be noticed that the rate of flow is not in inverse proportion to the thickness of the cake. Note, for example, that No. 4 flowed 58% as fast as No. 1, while the cake was $3\frac{1}{2}$ times as thick. In plotting this chart, cakes were formed of the thickness indicated, and clear water was forced through them, first at 5-lb. pressure, then at 10, 15, 20, and so on, a measurement of the rate of flow being recorded after each rise in pressure.

In the preceding experiments no cyanide was used in the solution, the purpose being to study the problem from a physical rather

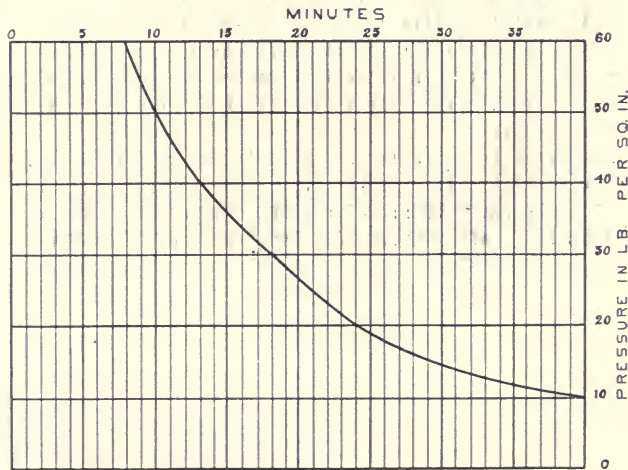

Fig. 79. TIME REQUIRED FOR DISPLACEMENT AT PRESSURES VARYING FROM 10 TO 60 LB. PER SQUARE INCH

than from a metallurgical standpoint. The next series of experiments was for the purpose of determining the time required to displace with wash-water the cyanide solution contained in slime-cakes. Cyanide was added to the pulp to bring the solution up to 1 lb. KCy per ton, and fresh wash-water was used to wash the

cakes. The results are shown in Fig. 78, where the curves representing the progress of displacement were plotted from titrations of the effluent wash-solution. Effluent solution-samples were taken at intervals of one minute and carefully titrated later. In each case the cakes had been formed for the same length of time (20 minutes) and were about $\frac{7}{8}$ in. thick. All other conditions governing the tests were held as nearly alike as possible, the varying factor being the pressure of displacement. In this series it was assumed that displacement was practically complete when the cyanide strength dropped to 0.1 lb. KCy per ton, or 0.005%. It was found that the cakes were washed with equal thoroughness at all pressures, and the amount of wash-water required was the same in each case, regardless of pressure. The benefit of pressure in filtration is therefore not to increase the efficiency of the water or barren solution-wash, but to decrease the time required to accomplish it.

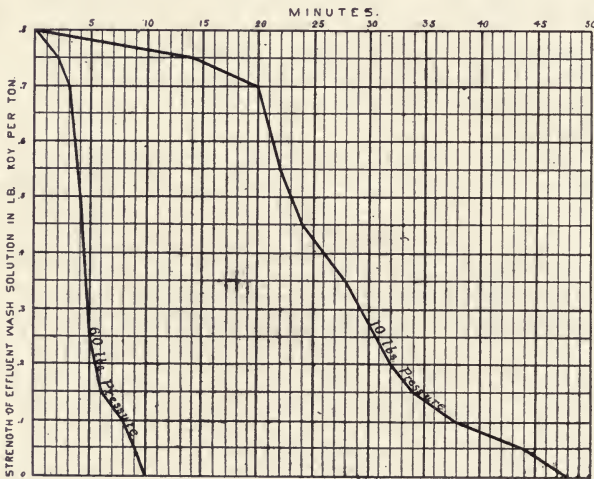

Fig. 80. COMPARISON BETWEEN DISPLACEMENT CURVES AT 10 AND 60-LB. PRESSURE

The great saving in time effected by washing under reasonably high pressure is apparent. To wash a slime-cake thoroughly requires a certain fixed amount of wash-solution, and the time required to pass this amount of solution through the cake depends entirely upon the pressure at which it is applied. The time required for forming the cakes also depends upon the pressure at which the sludge is applied to the filter-surface; therefore the capacity of a filter leaf in pounds of dry slime per square foot per day depends upon the pressure under which it is operated. The length of time required to wash a cake of this slime $\frac{7}{8}$ in. thick is represented by the curve in Fig. 79, which was plotted from the results shown in Fig. 78. In the test recorded in Fig. 78, it was assumed that when the strength of effluent solution dropped to 0.1 lb. KCy per ton, the

cake was sufficiently washed for practical purposes. Another displacement test was made to show the comparative length of time required to completely displace the solution in the cake. The curves representing the progress of complete displacement are shown in Fig. 80, where a test at 10-lb. pressure and one at 60-lb. pressure are recorded for comparison. The comparison is the more interesting because 10-lb. pressure is about the pressure equivalent of a 20-in. vacuum.

It is interesting to note that the rate of flow of filtrate while washing at 60-lb. pressure was 20 gal. per minute, and at 10-lb. pressure it was 4.16 gal. per minute. At 60 lb. it required 10 minutes for complete displacement, and at 10-lb. pressure it required 48 minutes; therefore the amount of water required was 10 by 20, or 200 gal. in the first case; and 48 by 4.16, or 199.68 gal. in the second case.

The curves show that the last traces of cyanide solution are more slowly displaced than the bulk of solution, which is due to osmotic action between the wash-water and solution. At 10-lb. pressure it required 10 minutes to reduce the effluent wash-solution from 0.1 lb. KCy per ton to zero, which was the total length of time required for complete displacement at 60-lb. pressure. The results of the experiments here recorded, as well as several hundred others I have made, justify me in the conclusion that economy in filtration lies in the use of comparatively small filter-leaves operated under pressure, rather than in large ones with vacuum. The capacity of a filter-leaf is dependent entirely upon the pressure at which it is operated. It seems a useless extravagance to use leaves in such a manner that only one-fourth or one-fifth of their real capacity is developed, and that is what is now being done with vacuum leaf-filters.

Take for instance any sort of vacuum filter-leaf and submerge it in a tank of sludge and operate it as a vacuum-filter. It will take probably three hours to form, wash, and discharge a cake 1 in. thick. Then take the same leaf and put it in an enclosed tank and operate it as a pressure-leaf, using, say, 60-lb. pressure, and exactly the same metallurgical results are obtained, but the time consumed is only about 45 minutes. Furthermore, the use of leaves under pressure will make for higher metallurgical efficiency, because when displacement can be rapidly performed, the washing of slime-cakes will not be slighted for want of time.

Successful use of filter-leaves under pressure is simply a matter of the mechanical design of the chamber containing them. Filter-leaves can be operated under pressure with the same degree of convenience with which they are operated with vacuum, and with a great saving in first cost and in maintenance.

Considering that if it were possible to provide a cover for an ordinary vacuum-filter installation, and operate it under 60 or 70-lb. pressure, its capacity would be multiplied four or five times, one cannot fail to be impressed by the possibilities.

JAMES' ANNUAL CYANIDE LETTER

By ALFRED JAMES

(January 1, 1910)

Once more Africa has become, if not the centre of interest, for the year, one of the most interesting centres. For many years with the exception of the period of the Denny controversies, attention has been directed to Western Australia, New Zealand, and Mexico for the latest improvements in practice. That Africa is once more calling favorable attention to its practice is due in no slight degree to the enterprise and caution of W. A. Caldecott, who, since, the retirement of J. R. Williams, of cyanide renown, has apparently been the ruling force in the adoption of solid improvement in practice. Sound in judgment, cautious in committal, and yet enterprising in policy, Mr. Caldecott first came into prominence by his extremely accurate forecasts of the advantages which would result from the adoption of tube-mills in local practice—his recently published paper, showing the work which has led to his recommendation of heavy stamps, has gained him a gold medal from the Institution of Mining & Metallurgy, and amply justifies the attributes with which this sentence opened. In boldly adopting a vacuum-filtration table for the classification and collection of his sand-pulp Mr. Caldecott has once more shown enterprise and earned high encomium from such experts as J. R. Williams, who is naturally enamored of a sand-product carrying only 1% of slime.

African practice is clearly in a transition stage. The suggestions of the Denny brothers—made too early, possibly, for their general adoption—although received with incredulity and ridicule, have undoubtedly borne good fruit, and while these suggestions may be modified by later available methods and practice, the results accruing from them are undoubtedly materially altering metallurgical practice on the Rand.

From time to time editorials and letters from correspondents assert that filter-pressing on the Rand has been tried and thrown out, but I can find little justification for such a statement. It is true Mr. Albu stated his intention of dispensing with filter-presses at the New Goch because of the difficulty of taking reliable 'lip-samples' when cyanide solution was flowing through the battery boxes (though at the same time retaining them at the Meyer & Charlton), but not only is the original Dehne-press plant at the Meyer & Charlton still at work, but a number of other Dehne plants have since been and are still being installed in South Africa—not on the Rand—as the result of the Denny plants.

It may be taken that the trend of practice on the Rand is to use heavy (2000-lb.) stamps as coarse crushers only, and to crush fine in tube-mills, avoiding the use of amalgamation plates after battery screens, and to amalgamate after the tube-mills only. In some mills the battery screens are as coarse as 3-mesh.

In Western Australia interest has mainly centered on the treatment troubles of the Lancefield and on the introduction of fixed sub-

merged filters at Oroya Brownhill, Lake View, and other Bewick-Moreing mines.

In Mexico good work is being done all the time investigating the conditions for the solution of the various silver-carrying minerals, and improving tube-milling, agitation, and filter-pressing.

In the United States new plants appear to conform to Mexican practice, the Homestake still standing as the notable example of original methods successfully pioneered.

Crushing.—In these notes for last year a prophecy was hazarded that the era of 2000-lb. gravitation stamps would soon arrive. Already stamps of this weight are actually in hand. It appears to be established on the Rand that particles 0.25 in. diam. are the largest economically suited for subsequent tube-milling, and experiments there are consequently on a screen of 9 holes (of 0.27-in. aperture) to the square inch. Cabled reports show an output of 17 tons per day from the 1890-lb. stamps of the West Rand Consolidated, and it is suggested that the 2000-lb. stamps at the City Deep will output 20 tons per day. All new stamps appear to be designed from a development of Mr. Boss' suggestion, with long heads, short stems, and low, open-fronted mortar-boxes, without anvil-blocks. Mr. Caldecott's paper in the Institution of Mining & Metallurgy, referred to above, is most interesting and useful, and gives tabulated results with varying factors such as weight, water-feed, and screen-area. Truscott, however, shows the increased duty to be only directly as the increased weight of the heavy stamps, yet the saving in convenience, cost, and labor on the fewer and larger units is such as to secure their adoption. A most remarkable point the author makes is that, whereas using 8 of water to 1 of ore the crushing duty on the Simmer Deep was only 5 tons per stamp per day containing 11% of plus 60 particles, at the present time using tube-mills as fine grinders, the crushing duty with only 6½ water to 1 of ore is no less than 8½ tons per day with only 1.61% of plus 60 for exactly the same cost. They thus obtain a higher tonnage and a higher extraction for the same cost per ton, and effect a saving in water.

In Rhodesia practice is not infrequently materially different from that on the Rand. Just as the Giant for some years pioneered in practice, getting a heavy output per stamp (10 tons per day) so now Rhodesia makes a departure from Rand practice by the adoption of the Chilean mill, though we have as yet no information as to better results having been obtained there than those of Francisco Narváez at Pachuca, to which I referred in my last notes.

Tube-Mills.—I have in another paper referred to the coarse material (0.25-in.) now being fed into tube-mills on the Rand. From elsewhere one enthusiast advises me of his successful practice with a 1½-in. tube-mill feed. Opinion is still divided as to the most suitable proportion of tube-mills to stamps. At El Oro a much higher proportion is used than in Africa, but the outside figure seems to be that of the Waihi Grand Junction Co. with 9 tube-mills to 40 stamps. At the Benoni, in South Africa, it is proposed to put in

3 tube-mills to every 40 stamp-heads, which is a great advance on local practice. Walter Neal, of the Dos Estrellas, Mexico, wishes me to call attention to a rational development of all-sliming practice. This is to separate at once the original, impalpable slime from the tube-mill slime (granular particles), so that the former may receive separate and usually much more rapid treatment than the latter.

The battle over tube-mill liners is still undecided. Iron plates are used in Western Australia, honeycomb blocks and rib-liners in New Zealand, silex blocks in South Africa, and rib-liners in Mexico. Rib-liners appear to increase the efficiency of the tube-mill, and also the power-consumption, and they also appear to overcome 'slip' of the pebbles. It looks as if rib-liners would be more and more widely adopted, though one is a little surprised at the non-adoption of Barry's convenient and rapidly renewable system of mine-material cemented in honeycomb shells. Mr. Neal's open discharge appears to be gaining ground in Mexico. The convenience of doing away with the pierced baffle-plate or screen is obvious.

Dewatering and Classifying Pulp.—Probably the most original work of the year has been along this line. In America, Canada, Mexico, Australia, and Africa, new and original schemes have been evolved and put into practice. Possibly enthusiasm of the inventor has caused him to dream of displacing filter-presses, decantation plants, and vacuum-filters, but without for the moment looking at it from this point of view, one has to take note of at least two systems which have come prominently forward during the year. In the first place, the Dorr classifier has taken a forefront position in Mexican and American practice. Designed by the engineer who made a success of the Moore filter after the original failure at Mercur, it was a practical solution of one of the two difficulties at that time faced, apart from the operation of the filter itself, namely, (1) the separation of the sand, and (2) the thickening of the slime-pulp. By a simple system of reciprocating scrapers, working in an inclined trough, Dorr separates the sand up to 200 mesh or any required degree of fineness, handling about 700 tons of pulp per day with less than $\frac{1}{2}$ hp. The product is clean and attractive. Mr. Caldecott has been working on quite other lines. By placing a circular board or baffle near the discharge-end of a small (8-ft.) cone, right over the discharge but at the same time clear of the sides except at the point of support, he overcomes the irregular action of those cones caused partly by the collapse at intervals of material settled on the sides, and he keeps the fine-slime in suspension. The sand is delivered to a filter-table somewhat similar to that illustrated by Parrish or Hunt. Mr. Caldecott describes his method in detail in the *Journal* of the Chemical, Metallurgical & Mining Society of South Africa for May 1909, and J. R. Williams tells how he produces a clean product of sand containing only 20% of moisture and 1% of slime. Mr. Caldecott's spitzkasten diaphragm—not to be confounded with the baffle used in tube-mill

feed-cones (spitzlutten) to divert the upward flow of water from the bottom—appears to be an ingenious contrivance for which he deserves much credit, and his adoption of a filter-table enables him to provide a much drier product (he claims 15% of moisture only) than that from a Dorr classifier. This is, of course, of no little importance where the pulp is to be mixed with KCy solution, but we have no note of the increased cost resulting from the use of Mr. Caldecott's filter, scraper, and vacuum-pump. On the other hand, Mr. Caldecott appears to accomplish, without power, by the mere addition of a fixed diaphragm, what Dorr requires power (little, it is true) and moving apparatus to accomplish.

Solution of Metals.—The use of the Brown agitator has progressed by leaps and bounds. In Mexico and the United States no new plant appears to be considered up to date without it, and already its use has spread to eastern Asia, India, South Africa, the West Coast of Africa, and to South America. Singularly enough, Australia appears to be the one gold-mining territory, though the agitator originated in New Zealand, in which this appliance has not yet been adopted. The reason for this may lie in the cessation of construction of new plants rather than in a lack of appreciation of the efficiency and economy of the new method of agitation. Already, indeed, operators seem to be trying to still further improve the work of the agitator. Henry L. Swan proposes to economize by his patented system of re-heating the air and thus to make it go further as well as to obtain the advantage in extraction and settlement resulting from the employment of heated solutions. In Mexico, C. V. R. Cogswell proposes the adoption of ozone instead of air. To the lay mind it may appear to be a rather expensive substitute, but facilities for the manufacture of ozone appear plentiful at Guanajuato and we may yet hear more of the suggestion. The method proposed by Messrs. Grothe and Mennel, of continuous treatment in Brown agitators, can scarcely, however, be favorably considered. A system of continuous decantations, using these tall tanks for this purpose, would not only involve what the industry is now trying so hard to avoid, namely, the handling of the huge quantity of solution per ton of slime treated, but also the idea of settlement in tanks not so fitted for this process as the shallow tanks of great superficial area in use in South Africa. Thus, if slime settles 6 inches in one hour, in a 60 ft. diam. tank 10 ft. deep, this means 1414 cu. ft. of clear solution per hour, as against only 88 cu. ft. in a much more costly tank 15 ft. diam. by 45 in. deep. What the industry is set on obtaining is a high extraction with the handling of only one, or at most two, tons of solution per ton of dry slime treated.

Recovery of Gold or Silver-Bearing Solution.—This, in other words, is the crux of the slime-treatment question, and has probably during the past year attracted more attention from skilled men than any other phase of the metallurgy of the precious metals; nor have the efforts put forth been successful. New methods on entirely new lines, with both natural and assisted settlement, have

been promulgated. Their success in practice has yet to be accomplished.

It is of course well known that originally J. R. Williams evolved a decantation system for South Africa, and Messrs. MacIntyre and Sutherland a filter-pressing system for Australia. The former method has been carried to a remarkable degree of efficiency, superior to the results obtained by the Mexican pressure-filters, and practically equal to those of the fixed submerged filters, by means of huge and costly plants, costing in some cases upward of £50,000, and handling up to and above 12 tons of solution per ton of dry slime treated. There now seems little reason to doubt, however, that even on low-grade African slime the adoption of filter-pressing would have been of great advantage, and would have saved heavy loss and much capital expenditure. Apart from the greater cheapness of a filter-press plant, and its heavier cost of working, amounting to more than 5d. per ton, there is the question of depreciation, which in decantation plants is a heavy figure, even if one takes the life at 15 years. It is now admitted that on the best Rand plants there is a loss of not less than 8d. per ton of dissolved gold run away with the residue. Filter-presses would have recovered 7d. of this, and would have saved the cost of handling of huge quantities of solution. But it must be remembered that the good decantation results shown may only obtain at the best plants. The letter published by George Mackenzie of the Adair-Usher Process, Ltd., in the *Mining and Scientific Press*, July 17, 1909, shows how much behind these figures some of the other plants were. The best Rand slime-plants now have four transfers, and handle three of water to one of settled pulp at each transfer. Treatment-costs, however, are low, varying at the mines of the four chief groups (Eckstein, Rand Mines, Gold Fields, and East Rand) from 10.33d. at Knights Deep, including cyanide and supplies, to 1s. 6d. at Simmer Deep, 2s. 6d. at Jumpers Deep, 2s. 10d. at French Rand, and 4s. 7d. at a well known mine (for accumulated slime, current pulp being handled much cheaper) for the months reviewed. Experiments with vacuum filtration have shown, however, that a final residue of 0.15 dwt., or an extraction of, say, 92.5% is possible with a dissolved value remaining in the residue of under $\frac{1}{2}$ grain of gold per ton of dry slime. The best present practice appears to show an extraction of close to 88%, allowing for gold in solution flowing away with the residue. To revert, however, to the newer natural or assisted settlement methods of recovering solution, that which first occurs to one as possibly the best tested is the Dorr pulp-thickener. Dorr, however, does not appear to claim, as do others, that his thickener is available as a complete treatment scheme, but regards it as an accessory to filtration. This thickener consists of an ordinary slime-settling tank to which is fitted a scraper arrangement revolving at a very slow rate, say five revolutions per hour, and thus taking very little power. The scrapers deliver the settled, thickened pulp at an outlet at the centre of the bottom of the vat. If the delivery is continuous the pulp is reduced from, say, 10 of water to 1 of dry

slime to $1\frac{1}{2}$ of water to 1 of dry slime. If worked intermittently an output of 1 of water only to 1 of slime appears to be maintained without difficulty.

An enterprising endeavor in Mexico to obtain a highly thickened pulp ought here to be mentioned. A cone 34 ft. diam. by 35 ft. high is fed with 400 tons of dry slime per day, containing 9 of water to 1 of dry slime. The underflow contains not less than 3.5 to 4 tons of water to every ton of dry slime, with an absolutely clear overflow. If, instead of one cone only, a series of smaller cones had also been used, results might have been obtained more nearly resembling those of the Messrs. Denny in Africa. From their 35-ft. cone H. S. and G. A. Denny obtained an 18 to 25% product from a feed of 3000 tons of pulp, that is, dry slime plus solution, per day. This was further thickened in eight small cones, worked in two series of four each, down to 35% of solid matter. Another method of settlement comes from Australia. Pulp is settled in a cone, and the thickened pulp-overflow at the bottom is received on a belt caught between consecutive series of rollers which squeeze the pulp between the upturned sides of the belt until a thick, somewhat caked product is delivered. This scheme does not appear to have yet established itself practically.

From Africa comes the Arbuckle process. In this system the pulp flows into a cone, and the thickened pulp is caught between rollers which deliver it sausage-fashion. I understand the experiments originally conducted by one of the most enterprising of the local groups did not result sufficiently favorably, but other groups appear now to have acquired an interest in the process, which is stated to take the sand-pulp as it comes and to deliver an absolutely continuous output of thickened pulp, sand, and slime together, containing only 20% of moisture. From a glance at the patent illustrations it would appear as if the arrangement of rolls were not yet sufficiently practical for ordinary usage. But even if the machine will do all that is claimed, it is still a long way from a simple one-treatment, equal-solution process superior to decantation, and equal in recovery to filter-pressing, though the figures certainly look attractive; for, assuming that the ordinary mill-pulp is dewatered down to 20% moisture, and that the thickened pulp is diluted with KCy solution to 2 to 1, and agitated, and again dewatered to 20%, then there is a recovery of $1\frac{4}{5}$ tons, or 90%. This is not nearly a high enough recovery of dissolved metal, and the pulp is again handled for another recovery of $1\frac{4}{5}$ tons, or $3\frac{3}{5}$ tons of solution in all, and a 99% recovery of dissolved metal, which, for reasons to be shown later, is the lowest recovery one can afford to be content with in practice even on low-grade ($1\frac{1}{2}$ to 2 dwt.) slime. There would be three transfers, two agitations, and two precipitations, with $1\frac{4}{5}$ tons of solution for each ton of slime, using the second wash as original solution for the next charge, with a consequent slight lowering of the percentage of recovery.

The most recent settlement process comes from Canada and differs from the others in that the inventor delivers his settled thickened pulp under water, and thus avoids the difficulties incidental

to all other methods arising from the pressure of fluid above the thickened pulp outlet that is liable at any time to rush through channels of least resistance. Horace G. Nichols has described his apparatus in a paper to the Institution of Mining & Metallurgy (Vol. XVII, p. 293) and more recently in *The Mining Magazine* for November 1909. Briefly, his apparatus consists of a V-shaped inclined trough with a box-bottom in which a continuous belt operates under the longitudinal opening along the bottom of the V. The thickened pulp is deposited through the opening at the bottom of the V onto the belt which, operating in water or pulp at an angle of 18° , which is also the angle of the bottom of the trough, has its upper end emerging from the water at the end of the trough. The thickened pulp adheres to the belt and is stated to be not disturbed during its slow travel through the water. The thickened pulp is detached at the upper end of the belt after it emerges from the surface of the pulp by a system of water jets or by a scraper. Mr. Nichols claims a settlement to 27% moisture, and it will be seen that the considerations applying to the Arbuckle settler apply with still greater force to the Nichols apparatus, and that a very large amount of solution, say 8 to 1, must be handled and precipitated to effect a 99% recovery. The idea, however, is certainly ingenious, and seems more practical than the Arbuckle in its patented form. Even if it is not as useful as a treatment-process as the author hopes, it would appear to have a field as a dewaterer or as a de-solutionizer prior to thorough washing-filtration, though it would be well to know more of the working of the method for keeping the box-bottom, in which the belt moves, clear of the thickened pulp.

Having thus dealt with the recent settlement-processes, it becomes necessary to consider the results of the much-advertised vacuum-filters. If one regard the work of the fixed immersed type of vacuum-filter in Mexico or elsewhere, that type being most generally adopted, it is found that its function appears to be mainly that of a settler, and that whether one uses natural settlement and drainage, a pressure-filter, or a fixed immersed filter, the resulting recovery is almost the same, namely, the total solution less the 33% or so remaining in the thickened pulp. Recovery is therefore increased by the dilution of the original pulp; the more dilute the pulp the higher the recovery. My observations in Mexico led me to ascribe to the fixed submerged type of vacuum-filter in Mexico a recovery of 77 to 89% of the metals in solution. The latter looks like a high figure, and is obtained usually by taking the original solution, say 2 to 1 of dry slime, and deducting from it the 30% of moisture still remaining in the thickened cakes or settled pulp, representing a recovery of 85%. When the proportion of solution is higher, say $2\frac{1}{2}$ to 1, the recovery is still greater, being 89%. Of course, it will be found that the cakes discharged from the filter usually carry more than 30% of moisture. At one of the well-known plants, for instance, the moisture is 45 to 50%, but this may be taken as mainly water introduced at the time of discharge. This result, apparently high, is confirmed by taking the advertised records and omitting

the washing, which shows 87% extraction. Prior to the introduction of these filters much higher metal values were simply flowing away, so that in spite of low recoveries the introducers of these filters have done a great service to the industry; but even taking an ore worth only 30s. per ton, and assuming an extraction of 90%, equivalent to 27s., then the loss is not less than one-tenth of 27s., or 32d. per ton of ore, almost the whole of which would be recovered, at an extra expense of 6d. only, by Dehne presses, or without extra expense by the employment of thorough washing instead of mere settlement.

In the above remarks I have not referred to the traveling basket filter of the Moore or Barry type, as this is on quite a different footing from the non-washing, fixed, immersed, or pressure-filters. The Moore and Barry filters do good work, and it has been a matter of some little surprise that the former has not been more widely adopted in Mexico. Indeed, the decision of the Dos Estrellas company not to install the Moore filter so impressed me that I had special enquiry made into the matter. It appears that the Moore costs are higher than those of the fixed submerged filters, and that there is a liability to breakage of baskets which is extremely costly and inconvenient; that twice at Pachuca the baskets have been dropped, intentionally or otherwise, and smashed. This seems a poor argument for not adopting a high-recovery filter unless costs are very much higher, which might show bad design or bad management—or more probably that the Moore filter is handling at Pachuca straight slime, that is, slime not previously treated by decantation, instead of the decantation residue frequently fed to filters of the submerged type. Even so, the cost at Pachuca should not exceed 8c. per ton of dry slime or 6c. per ton of solution recovered. As for the smashing of frames, this is a mere question of mechanics which has been satisfactorily dealt with at the Liberty Bell, Waihi, and elsewhere, and can be as readily disposed of in Mexico.

There can be no question of the superiority of the results of the traversing type to those of the present fixed submerged type, and anyone can see this who will take the trouble to read the remarks of the workers of the latter type (see, for example, A. M. Smith in the *Mining and Scientific Press*, July 10, 1909). They actually at Goldfield run their discharged submerged filtered residue into a pond with wash-solution, settle the residue behind a dam, and decant the gold-carrying wash-solution, and then run on a further 15,000 or 20,000 gal. per day as a further wash to absorb and save the gold-bearing solution remaining in the residue. This water they subsequently decant and return.

To recapitulate, the position of slime-treatment appears to be as follows: The only methods giving really efficacious results, recovering not under 99% of the gold dissolved, are the Ridgway filters and Dehne presses. The former is handicapped by the necessity for a feed of thick pulp (not over 50% moisture) for cheap work (4d. per ton), but now that slime-settlers are advanced to such a degree as above indicated (the effluent containing 20 to 30%

only of moisture) the securing of a proper thickness of feed should be a relatively simple matter. Again, the Ridgway is handicapped by the requiring of skilled supervision. I am inclined to agree with this view, but on the other hand the skilled supervision, as well as the repairs, are all included in the above working cost of 4d. per ton. Similarly, the Dehne press is limited by the greater cost of operating it, namely, 1s. per ton, but it can handle thin pulp and gives a high recovery.

Next to the above, and close to them in point of high recovery, comes the Barry (crush) filter. This appears to have the advantage over the Moore of a better plate and of no blowing back of displaced metal-carrying solution. The necessity of acid treatment of Barry's filter-leaves is unknown; the cloths are brushed or washed when taken off for repairs, and they last for months, in some cases for more than a year, and the cost appears to be between 4d. and 6d. per ton of dry slime handled.

I calculate the efficiency of the various machines or methods as below:

	Recovery of dissolved metal values.	Cost per ton of dry slime.
(A) Ridgway (automatic).	99.5% (averaged over a month on 500 tons per day).	4 to 5d. (actual).
(B) Dehne (filter press).	99% (with efficient washing).	1s. (actual).
(C) Barry 'Crush' (traversing basket vacuum-filter). Barry (possible).	96% (as used at Waihi). 99% (with modified wash).	5 to 7d. (actual).
(D) Moore (traversing basket vacuum-filter).	91%.	I estimate at 8d. plus royalty [stated in Mexico to be higher than (F) Brown (old costs)] 31c.
(E) Rand Decantation.	Either side of 85%.	6 to 8d. omitting solution costs.
(F) Fixed Immersed Filter (coir leaves non-wash).	77 to 89%.	I estimate at 6 to 10d. (acid alone may be 2d.) Bosqui (old costs), 26c.
(G) Pressure Filters Non-Wash (without power).	61 to 76%.	3½d. (filter by gravitation without power).
(H) New Ridgway Non-Wash (500-ton unit).	66 to 70%.	1d. (actual).

It says much for the Dehne press that no instance has yet oc-

curred to my knowledge of it being displaced by a vacuum-filter, with the possible exception of the Ridgway at the Great Boulder and of the Barry at Waihi. I have to place the Moore after the Barry, owing to its less efficient frame and the loss of dissolved metal-value from the blowing back or reverse pressure of fluid, that is adopted for dislodging the cake. There was much trouble to get over this with the Ridgway when it was found that the metal-values blown off were not of valueless wash, but rich in gold. The amount of loss from this cause varies with the construction of the frame; for the above type it may be assumed at under 5 per cent.

I said at the beginning of these notes that one could not afford to be content with a less recovery than 99% of the dissolved metal content. With a 1½-dwt. extraction and a pulp containing 40% of solid matter a washing displacement of 69% (equaling a total recovery of 96%) shows on 100 frames, handling eight charges per day, a loss of £2500 per annum in unrecovered metal. If better-designed plant operating at precisely the same expense gives 92% washing displacement (readily obtainable in practice) the loss of unrecovered metal is only £700 per annum. Even if one allow ½d. per ton higher cost for more efficient washing, the total net gain would be not less than £1500 per annum.

I purpose here to refer to the new type of Ridgway filter (500 tons per day unit), regarding which I hitherto have given no details, as it appeared to me that, working without washing, the results could scarcely command serious attention. In view, however, of the enterprise which has induced them in Mexico to recover considerable metal from their decantation residue by means of pressure-filters, figures on this machine will probably be of interest. This filter differs from the standard Ridgway filter in that each flat plate is substituted by a basket or group of five vertical plates; the machine has eight times the surface of the standard Ridgway. It has been in regular use in Australia for some 2½ years, has never failed to treat the whole product sent it, amounting at times to 687 tons (dry weight) per day. It is reported to work automatically and without attention save for one man of superior grade on the day shift, no labor being employed on the afternoon or night shift. The costs, approximating 0.906d. per ton, are stated to be as follows, including purchased power at a high cost measured by ampere metre:

Power for vacuum and for turning machine, 4.5 hp., at 3s.....	13s. 6d.
Labor for running filter, one man at 10s. per day	10s.
Repairs and upkeep have proved infinitesimal, say	5s.
Cloth, 10 yd., at 7½d.	6s. 3d.
Light, oil, waste, and sundries	3s.
Total	£1 17s. 9d.

The feed into the machine is 50% solid, or apparently precisely similar to that fed into the pressure-filters at Mexico El Oro. They claim a high figure for recovery, based on the paucity of value in the treated product. Working as they do, however, I estimate it at 70% only. From the above figures this filter would appear to

have some value as a cheap final method of recovering metal from decantation residue. For some time past, however, they have been using this machine on direct pulp with washing, but for this purpose I have as yet no figures which enable me to recommend its use.

Difficulties.—The chief difficulties in treatment encountered this year appear to have been due to pyrrhotite and graphite. Investigation on the former was carried out years ago by A. C. Claudet, who obtained entirely satisfactory results from fine grinding and agitating with dilute cyanide solutions. A plant on these lines, namely, stamp-mill, tube-mill, agitator, and filter-press, was laid down in Korea and operated by Mr. Marriner with entirely satisfactory results, without roasting. Graphite has, however, caused much more difficulty. Finely divided, and resembling an oily scum or film on the surface of the solutions, it has caused much trouble in Australia and in India. On looking up previous experience on the subject I find that at Charters Towers an old sailor made £30,000 by sun-drying and disintegrating, prior to cyanidation, heaps of old graphitic residue previously deemed untreatable. By this means 4 to 6-dwt. tailing was reduced to $\frac{1}{2}$ to 1 dwt. at a cost of 3s. 6d. per ton, including carting. Generally, the difficulty caused by graphite has been overcome when roasting (which is the natural remedy) is not employed, by agitation with air, or by exposure to the sun for a period of six months or a year, with subsequent disintegration and aeration.

Errors in Estimation of Gold in Solutions.—Whitby states (*Journal*, Chem. M. & M. Soc. of S. A., May 1909) that he could show figures giving losses as high as 70% of the total gold in slime-pulp residue by simple evaporation, and in practice, using the greatest care, the loss seldom fell below 30%. All solutions should be evaporated gently with litharge.

Cleaning Up.—Tilting furnaces gain in favor as the use of them extends. A tilting furnace, with oil burner, as used by Mr. Yates is ideal for running down gold precipitate. Unfortunately, however, when power runs short, the amount of air used by such a burner becomes no longer a negligible factor.

ALFRED JAMES' ANNUAL CYANIDE LETTER

(February 26, 1910)

The Editor :

Sir—I would be glad of the opportunity to supplement the information conveyed to your readers on one point in Alfred James' annual letter. He says, on page 45, that he does not know of any instance where the Dehne press has been displaced by a vacuum-filter. I may state that such a case occurred at the Creston Colorado mine, in Sonora, Mexico; also at the El Rayo mine, in Chihuahua. filter-presses (not of the submerged-leaf but of the frame type) were displaced by a vacuum-filter. In both instances the change was amply justified by results and has never been regretted.

It would also be interesting if Mr. James would inform us why.

in speaking of the "fixed immersed vacuum-filter" he unconditionally labels it 'non-wash'. If this is his unbiased judgment on the examples he has investigated he must have been singularly unfortunate in his choice of examples. I have had a sufficiently wide experience with this type of filter to state emphatically that the description 'non-wash' is misapplied. The filter allows of thorough washing when properly cared for and well manipulated, and I have often seen cases where no trace of soluble gold and silver could be detected by assay of the washed cake. If any users are working it as a non-wash filter they are not obtaining the service of which it is capable. I admit that the system is not perfect, but in spite of its drawbacks I believe it will hold its own against any other at present in use.

E. M. HAMILTON.

Ventañas, Mexico, January 17.

The Editor:

Sir—I have read with interest 'James Annual Cyanide Letter' in the *Mining and Scientific Press* of January 1, and considering that Mr. James is thought by some to be a leading light on the whole question of both the chemistry and dynamics of the cyanide treatment of ores, I find many points to criticise, which I think should be pointed out, otherwise many investors might be prejudiced in favor of some particularly patented article to an extent that it does not merit. Furthermore, I know that your paper always endeavors to handle subjects from a purely disinterested and technical point of view, and I was therefore surprised to note that Mr. James could be so small-minded as to omit the name of Butters when referring to 'fixed immersed type filters'. I am not at present interested in any of the filters, though, like most men who have dabbled with the subject, I believe I have an idea that beats the rest, so I think I can express my opinion without prejudice.

In the summary given on page 46 the 'fixed immersed type' is charged with 2d. for acid, while the others are not. This is distinctly unfair; the necessity for using an acid bath for dissolving the calcium carbonate with which the filter-cloth becomes choked, depends not on the filter but on the nature of the ore and the system of treatment. I have seen just as much trouble with the Moore filter from this source at the San Rafael mill, Pachuca, as with the Butters. The Ridgway is a filter that I admire very much, but it has its special field. I refer to the old type, as I am not familiar with the new. The valves are a serious source of trouble, and, while the results are excellent on sands from silicious ores, it fails utterly where there is a large amount of calcareous clay and what may be termed sticky 'slime'. I would classify filters in the following order of merit: (1) Dewatering filters, for dehydrating and treating sandy pulp, where a cake can be formed rapidly; Nichols, Hunt, Wilfley, and Parrish. These are not suitable for slime. (2) Continuous-process filters, suitable for very fine pulp with some slime.

for small units, area too small for pure slime; Grothe and Carters and Ridgway (old type). (3) The slime filters, all adapted to slime, not adapted to sand; Butters, Moore, and Ridgway (new type). Butters best where space is a consideration, Moore can be sampled better, Ridgway the most complex.

Filter-presses are only suitable for rich solutions and for elastic and non-porous pulps, and for cleaning up and pressing precipitates from the zinc-boxes. Filter-presses cannot compare with vacuum-filters for economy of operation.

What we really need is a table of statistical data which will show the following facts when each filter in turn is put through the same series of tests on ores of widely different nature:

Total area in square feet of filter-surface per machine; capital cost per square foot area; gross weight per square foot of surface; interest on capital-cost; depreciation and repairs per square foot of surface; air required and vacuum-curve at all stages; filtering capacity in dry slime per 'hour square-foot surface'; current costs, that is, power for air; labor, filter-cloth, acid bath, etc.; percentage of moisture in pulp before filtering, and percentage after filtering.

An extraction percentage without comparing the above factors is misleading, because the extraction is more largely dependent on the chemical part of the process, the dynamics of fine grinding, and the method and time of agitation, than on filtering. The filter is merely a remover of solution.

I also notice remarks referring to crushing in the article. Mr. James states that on the Simmer Deep there was an increased efficiency in crushing when using less water; but the comparison was made after the addition of tube-mills, and it is not shown whether the increased efficiency were due to the step-reduction, or to the increased efficiency of both stamp-mills and tube-mills, with less water. This is important. My own observation shows that the crushing capacity of stamps increases with an excess of water, and also with increase of screen-area by the use of multiple screens, but decreases in a tube-mill; therefore dewatering should be the rule between the stamp-mill and the tube-mill.

Data are lacking on the efficiency of multiple-discharge mortars. I am certain that they would be of great use in a silver mill using concentration and the cyanide process. I also wish to take this opportunity of drawing attention to certain remarks made by Mr. James in regard to the Brown agitators (which are more generally known here in Mexico as Pachuca tanks), especially with regard to the suggested Grothe-Mennell continuous treatment which he disposes of in a few words. He speaks of "system of continuous decantations." Does he mean this in reference to the Grothe-Mennell process, or is he ambiguous? If the latter, it is certainly serious, considering the authority that Mr. James' words carry, for his statement might be taken as final by some young metallurgical engineer about to design a mill. If, on the contrary, he refers to the former, then Mr. James should read up more thoroughly before putting pen to

paper for an annual letter. Grothe-Mennell never suggested a system of 'continuous decantation' (?) sic: I beg to draw attention to an article by Leslie Mennell on page 15 of the February issue of 1909 of the *Mexican Mining Journal*, in which this suggested process is thoroughly described and data regarding a series of experiments are given, from which I take the liberty of making the following precis: "In the system of continuous treatment a series of tanks is placed at the same level; the pulp, however, is maintained at a slightly lower level in each succeeding tank of the series, the drop from first to last being just sufficient to allow the pulp to flow through the series at the same rate that it is being charged into the first tank; * * * as the finished product discharges from the last tank at approximately the same level as the intake, it then proceeds by gravity to the filter plant."

It is clear that in this manner all of the time now virtually lost in filling and emptying tanks is saved, and all tanks are constantly and usefully employed in cyanide agitation. Will Mr. James kindly explain what he means by 'continuous decantation'. Judging by my own training in metallurgy, the term 'continuous dewatering' or 'dehydrating' would be admissible, but 'continuous decantation' would be impossible. The generally accepted procedure here in Mexico is to use the Pachuca tanks solely as an agitator, and to trust entirely to vacuum-filters to remove the solutions, even non-continuous decantation being only practised in the large-diameter, low-height vats used with mechanical agitators.

Referring to the test and experiments of Mennell, an exact miniature of the standard Pachuca tanks was used. The first test was by the standard intermittent process. The ore was of silver, the metal being present as a sulphide, the more refractory being associated with slimed galena and iron pyrite which had escaped concentration; this with iron oxides and a little zinc blende caused a considerable consumption of cyanide. I have taken the following from the *Mexican Mining Journal*:

The test on this ore by the ordinary system, agitated for 48 hours, gave the following results:

OLD INTERMITTENT PROCESS

Amount of finely crushed ore used, kilos.....	Amount of solution, kilos.....	Time agitated, hr.	Strength cyanide solution, %....	Consumption cyanide kilos, per ton	Head value silver grams, per ton.	Residue value silver grams, per ton	Extraction, % ..
70	100	0	0.39	0	349
		12	0.26	1.86		118	66.0
		24	0.20	2.71		108	69.0
		36	0.13	3.76		98	71.2
		48	0.12	3.86		95	72.7

The second test was made using four of these same tanks connected in series as described. Pulp was fed at the rate of 70 kg. per day with 100 kg. of solution, this being the amount of the individual capacity of the tanks. The operation was continued for 8 days; after 5 days, when the process was running perfectly uniform, samples were taken from each tank and assayed. Samples were taken frequently up to the eighth day. The whole test is shown as follows:

NEW CONTINUOUS SYSTEM								
Amount of finely crushed ore fed daily, kilos	Amount solution fed daily, kilos.	Number of tanks.	Time of treatment, hours . . .	Strength KCN solution, %	Consumption KCN kilos, per ton..	Head value silver per ton, gm.	Residue value silver per ton, gm.	Extraction, % . . .
70	100	1	0	0.39	0	325
		1	12	0.30	1.29		146	58.0
		2	24	0.26	1.86		122	68.0
		3	36	0.20	2.71		101	71.3
		4	48	0.18	3.00		80	77.3

Assay of entire discharged residue was 80 gm. silver per ton, with an extraction of 77.3%. For full data on the subject I refer to the article mentioned, but I have shown enough to indicate that the subject should not be dismissed with a wave of the hand by a cyanide expert whose knowledge, while extensive, is not absolute. I trust that the above notes will be of value to some of my co-workers.

JOHN M. NICOL.

Mexico City, January 20.

(April 2, 1910)

The Editor:

Sir—In your issue of February 26, I notice two letters by E. M. Hamilton and John M. Nicol, respectively, in which they take exception to certain statements made by Alfred James in his annual cyanide letter. I am quite in sympathy with both these gentlemen. While at Kalgoorlie, Western Australia, I presume I handled a larger tonnage than any individual manager in that district with the Dehne filter-press. The combined tonnage of the following mills was all handled by that press: The Great Boulder Perseverance Gold Mining Co., Ltd.; The South Kalgurli Gold Mining Co., Ltd.; The Hannan's Public Crushing Co., Ltd. These three properties had a combined tonnage of over 35,000 tons per month, all handled in the Dehne press.

My experience, which covered a period of over eight years, taught me that you could not secure a perfect wash with it. This was particularly true where the product going to the Dehne press

was not carefully classified. The cakes channeled and there was more or less gold in solution thrown out with the sand or tailing. This prompted me to investigate the Moore vacuum-filter and with its use I had the tailing from most of the mines in the Kalgoorlie district tested, extracting gold with the Moore vacuum-filter by simply washing discarded tailing from the dumps of all the mines in the district. I had a great number of tests made by A. J. Wyly under my personal direction. We improvised a small unit of the Moore vacuum-filter, but the results were all most satisfactory and showed conclusively that the washing of an unclassified product was more efficaciously done in the Moore filter than a classified product in the Dehne press. The amount of gold in solution in the tailing from the Moore filter was uniformly low, and I know of no filter where the washing is so perfectly done. I am satisfied that there is no comparison between the Dehne filter-press and any of the submerged types of vacuum-filters now in use. All of these vacuum-filters are superior in every way as to costs and efficiency to the Dehne, and it is for this very reason that George Moore invented and introduced the first successful vacuum-filter at the Mercur mill in Utah, U. S. A. The facts brought out by the numerous tests made with the Moore vacuum-filter at Kalgoorlie were never published, but copies of results were given to all the managers on the Golden Mile. And the reason why so many Dehne presses are in use today in Westralia is because the installation of these presses was effected at great expense. English conservatism, in this case resulting in extravagance, has since kept them in use.

RALPH NICHOLS.

Gilmore, Idaho, March 8.

(May 28, 1910)

The Editor:

Sir—In Mr. James' annual letter on cyaniding in your issue of January 1, he gives a list of different filtering machines with the percentage of recovery of dissolved metal values and costs. The table is headed by the Ridgway with 99.5% recovery, which may be so; but I think the figure is excessive. On the Associated Northern mine we found that when everything was in good order, 95% of the dissolved gold was the average recovery; at the Associated, it was not quite so high; and at the Perseverance about 97%, and, although I have no data on this point from other mines, yet it is doubtful whether 99% would be the average, even with efficient washing. I am not trying to depreciate the working of the filter-press by any means, as it will hold its own here against the vacuum process; but poor washing does go on in the press at times, even when conditions are good for high recovery. The two vacuum-plants at work on old dumps in Kalgoorlie are not doing such extra good work, although the residue being treated is rather refractory. With reference to graphite in cyaniding, Mr. James says that "roasting is the natural remedy." My article on this subject in the

Mining and Scientific Press shows that this is not the case, and I have had very good opportunities of studying it. Graphite comes through the roasters unchanged, although perhaps a very small percentage may be burned. Mr. James is partly right when he mentions exposure to the sun. We found that, when the extraction was low on account of graphite, a residue assaying, say, \$3 per ton, when re-mixed with sump-solution of 0.04 KCN, pumped into a filter-press without any agitation, and washed for only ten minutes at 75-lb. pressure, yielded a final residue would be as low as 70c. to \$1 per ton. In most cases, this did not need exposure to the air for many hours, although longer exposure gave a higher extraction at times. Graphite is a peculiar mineral to deal with, and being such a staple thing, it needs much study.

M. W. VON BERNEWITZ.

Kalgoorlie, Western Australia, March 15.

SILVER ON FILTER LEAVES

(April 2, 1910)

The Editor:

Sir—While recently overhauling some vacuum-filter leaves, which had been used in filtering silver-bearing solution from Tonopah ore, I noticed a metallic white plating or scale on exposed, that is unpainted, iron parts of the filter-leaf and where the paint was rubbed off. This occurred both in spots on the iron piping inside the canvas cover and also on the nails in the wooden head-piece. Selected portions of this scaly material proved to be silver, when tested. It would be interesting to know how much silver is deposited inside the solution piping in various cyanide mills of the United States, or in Guanajuato and Pachuca. Probably the total amount is not great, but it may still be more than most people think.

DONALD F. IRVIN.

Bodie, California, February 26.

RECENT MILLING PRACTICE

By A. E. DRUCKER

(February 19, 1910)

For more than a year past I have been visiting a few of the principal gold-mining districts of the world for the purpose of making a detailed study of milling and cyaniding methods. A short description of some of the more important changes in these various places visited is here given. A more detailed account of the methods at Unsan, Benguet, Kolar, Waihi, Rand, and Kalgoorlie will be given in a series of articles to appear in *The Mining Magazine* and the *Mining and Scientific Press* within the near future.

Unsan, Korea.—The Oriental Consolidated Mining Co. possesses the most important gold quartz mines in eastern Asia. While other

Korean mining properties are now recognized as possessing dividend-paying resources, the Oriental Consolidated mines have heretofore been the only ones operated continuously on an extensive scale by modern methods in the Empire. It is safe to say that this company is the only one operating in Korea at the present time at a profit. Its mines are producing at present about \$125,000 in bullion per month, and has produced to date over \$12,000,000, of which about 40% has been paid in dividends. The success of the Oriental Consolidated Mining Co. has been largely due to the good management of H. F. Meserve, who has been its leader from the beginning. The company has a total of 230 stamps in five different plants, crushing about 30,000 tons of low-grade gold ore per month. It is quite base, containing from 5 to 6% gold-bearing sulphides, with very little silver. Considering the methods of milling and cyaniding in the past, remarkably good extractions have been obtained. The present treatment consists in stamping, plate amalgamation, concentration on Frue or Union vanners, and cyanide treatment of the concentrate, after mixing with coarse sand, by the 18-day percolation method. This cyanide treatment gives an actual extraction of 84% of the gold. The above method, on a \$5 to \$6 ore, according to the 1909 annual report, gave an actual gold extraction of a little over 82%. Of this the recovery by plate amalgamation was 46%, by cyaniding the concentrate 36, and 6% was in the cyanide residue dumps, leaving only 12% actual loss.

During 1910 the O. C. M. Co. has decided to make extensive changes at its reduction plants. I shall shortly re-design and carry out these changes for the company, the intention being to bring the concentration plants up to a more efficient point by installing classifiers and grading into three products. Wilfley tables will be used for coarse sand, Frue vanners with corrugated belts for the fine sand and slime, and cement slime-tables to further treat the residue from the slime vanners. The final residue from the concentration plants is to flow to waste, being too low in grade for further profitable cyanide treatment.

The concentrate (200-mesh) is to be all-slimed in tube-mills in cyanide solution. The resulting slime, together with the slime sulphide collected from the vanners and cement-tables are to flow in cyanide solution direct to my patent air-agitation and continuous leaching vat. Upon completing the extraction here, the sulphide slime residue is to pass to my patent tangential vacuum-filter (a continuous slime-filter), where the remaining dissolved metal is to be removed. An actual gold extraction of 90% is expected from this sulphide by the above treatment. Other important additions to be made by the company are plants for treating old cyanide residue dumps. There are three of these having a total value in gold of about \$900,000. The material assays between \$4 and \$8 per ton. After completing a series of experiments on a practical scale, extending over a period of some four months, I came to the conclusion that the following method would be the most profitable for such material: (1) Re-concentration on Wilfley

tables, giving two products, namely, coarse sand residue, assaying \$1.25, and sulphide, assaying \$12 per ton. The product fed to the concentrators assays \$4 to \$5 per ton in gold. (2) All-sliming of the sulphide in tube-mills with water, so that all will pass a 200-mesh screen. (3) Dewatering the sulphide slime before cyanide treatment. (4) Cyanide treatment in tall vats designed to give an air-agitation and continuous leaching at the same time. (5) Filter-pressing or vacuum-filtering of the residue from the agitation vats to completely remove the dissolved gold.

The serious troubles in the direct all-sliming treatment are the presence of large amounts of ferrous sulphate from the oxidation of marcasite and arseno-pyrite, and also the fine charcoal scattered through the dumps. A re-concentration on Wilfleys at once rids the sulphides of the fine charcoal and washes out the ferrous salts and other harmful cyanicides with the sand residue. The further grinding in tube-mills gives the sulphide a final wash and prepares it for successful cyanide treatment.

Benguet, Philippines.—The only two gold mines of importance here are situated in the Benguet district, and are controlled by the Benguet Consolidated and the Bua Mining companies, of which the former is now on a dividend-paying basis. At the time of my visit the Bua mine had a 30-ton plant, consisting of two 3-stamp Hendy mills, and a cyanide plant. The treatment was simple plate-amalgamation, followed by a leaching of the sand by cyanide. The slime assayed from \$1 to \$1.50 per ton, and was allowed to run to waste. The ore milled averaged from \$8 to \$10 per ton, and was easy to treat, containing much calcite, some quartz, and a little sulphide. It has an alkaline reaction and consequently requires no lime previous to cyaniding. This company claims an 80 to 85% actual extraction of the gold in the ore.

The Benguet Consolidated is an up-to-date, progressive concern, a great deal of credit being due C. M. Eye, the superintendent, for making the work a success. Formerly the reduction plant consisted of two 3-stamp Hendy batteries, amalgamating plates, spitzkasten, sand cyanide leaching vats, and mechanical slime agitators. The slime was treated by the decantation process with poor results. The ore consists of a large amount of quartz, some calcite, and from 2 to 3% of sulphide. It assays about \$10 per ton in gold. The actual extraction was only about 65%. At the time of my visit numerous alterations in the plant were under way, including the addition of new sand leaching vats, Wilfley tables, tube-mill, Ridgway slime-filter, and a special treatment plant for the concentrate. I understand that most of these improvements have now been made, and much better results are being obtained. The ore treatment is as follows: (1) Crushing in water with stamps. (2) Outside plate-amalgamation. (3) Separation of sand from slime by spitzkasten. (4) Cyanide percolation of sand after a previous concentration on Wilfleys. (5) Cyanide agitation of slime after dewatering. (6) Vacuum-filtering of slime. (7) Concentrate from the sand to be all-slimed in a tube-mill and given a special cyanide treatment. (8)

Precipitation of gold from cyanide solutions by means of zinc shaving.

Kolar, India.—The most important gold quartz mines in this part of the world are situated at Kolar, in the State of Mysore, which are under the management of John Taylor & Sons. There are between 600 and 700 stamps in the district distributed among six different plants. The ore at Kolar is extremely simple to treat, and yields over 90% actual extraction by simple plate-amalgamation, followed by cyanidation of the sand in vats. There is only a fraction of 1% of sulphide in this hard quartz ore. It assays on an average about \$16 to \$17 per ton in gold. The extraction by amalgamation is between 70 and 80%, while that on the sand by cyanide leaching varies between 60 and 75%. For years the slime from the stamp-mills was stacked for future cyanide treatment. During the past year or so it has been the practice to mix as much of this slime as possible with the sand, and yet get satisfactory leaching in the vats, so as to prevent, as far as possible, the accumulation of further untreated slime. This is ancient practice, however, and besides I cannot see the economy in stacking slime for several months and allowing it to dry and cake before receiving a cyanide treatment with the sand. Would not the direct treatment of the slime alone yield a greater net profit? Evidently the Kolar people are beginning to think that it would, and have been doing their utmost to solve this problem. For more than a year past H. W. Leslie, consulting metallurgist to the Kolar group, has been experimenting on a commercial scale with the large untreated slime-dumps, trying to find the most profitable method. At the time of my visit to Kolar one Ridgway slime-filter and two tall Brown agitators were being experimented with, and as far as I could learn good extractions had been obtained. The Brown vats were quite satisfactory. The Ridgway was the first continuous vacuum-filter put to commercial use in dealing with large tonnages of gold-bearing slime. Mr. Ridgway deserves credit for his ingenious invention. What is wanted at the present time in a continuous vacuum-filter is a machine that is not only able to treat large tonnages of slime successfully, but also one that is simple in construction. No continuous filter has yet come to the front to take the place of the Moore or Butters type. Sooner or later some form of continuous filter will take the lead, for this method of slime-treatment is still in its infancy.

The Mysore, Champion Reef, and Ooregum mines possess some well-constructed stamp-mills built almost entirely of stone and steel. There are concrete mortar blocks and wooden battery frames at the Mysore. Stamps are being used at Kolar that weigh from 1100 to 1300 pounds. At the Mysore a new rock-breaker house has been constructed apart from the mill. Crushing is done in stages in large Blake crushers, and then in small Gates breakers, the whole arrangement being up to date. Although the Kolar district has been backward in its cyanide treatment during the past, I must say that I picked up many good points as regards mill construction, the arrangement of rock-breaker plants, melting and refining (furnace

arrangement), and zinc extractor-house work. The zinc extractor-houses and the arrangements of furnaces, where crude-oil burners are in use, compares well with the best I have seen in other countries. The permanent manner in which the Kolar people construct their plants is most creditable. I have found, as in Kolar, that gold-mining districts like the Waihi, Kalgoorlie, Unsan, and the Rand, have their own special strong and weak points in regard to ore treatment. If one wishes to study the best practice in stamp and tube-milling, go to the Rand; if it be slime-treatment (vacuum-filters and Brown agitators), go to Waihi; and for dry crushing, roasting, and pan grinding, see Kalgoorlie. I may sum up the chief gold-producing districts, as regards efficiency in treatment, not taking into consideration Mexico and the United States, as follows: Rand leads in stamp and tube-milling; Kalgoorlie leads in dry crushing, roasting, and pan-grinding; Waihi leads in slime treatment, agitation, and vacuum-filters; Unsan leads in concentration and cyanidation of concentrate; Kolar compares well in mill construction, bullion melting, and refining equipment. It is doubtful whether tube-mills would pay to install for grinding the coarsest of the sands with the present milling methods, where 30 to 35-mesh battery screens are being used. However, if it were a case of getting through more ore with the present size plants, then instead of adding stamps, better install tube-mills and put on 10 or 15-mesh screens.

CYANIDATION OF SILVER ORES

By LLOYD M. KNIFFIN

(February 26, 1910)

In striking contrast to the usual method of cyaniding Mexican silver ores is the treatment which we have been using at the Zambona mine in the Alamos district of Sonora, Mexico. The unusual feature is the extreme rapidity of solution of part of the silver in cyanide, and the peculiar advantage of concentrating before cyaniding. The ore consists principally of orthoclase feldspar, very much brecciated and filled with calcite. Distributed throughout the ore is the sulphide of silver, argentite, in all sizes down to minute particles. This mineral was formerly the chief object of mining in this camp, when transportation was expensive, and it sometimes occurred in pockets of considerable size. The silver sulphide is easily removed by concentration on Wilfley tables, and in this way an extraction of 50% of the total silver is obtained. For several years this method has been used, and the tailing stored. At present the mill is engaged in grinding and treating this ore with cyanide.

The process is as follows: Cyanide solution (0.075% free KCN) is mixed with the ore in the ratio of 6 to 1, and the sand separated and discharged to tube-mills by Dorr classifiers. The discharge from the tube-mills is returned to the classifiers, and the overflow from these goes to Dorr slime-thickeners. The underflow, at a ratio of 1½ to 1, is stored for delivering to the filter-presses as needed. Thus,

concentration and grinding in solution, without agitation of any kind, is all the treatment required to reduce a 16-oz. ore to 1.3-oz. silver per ton.

The ore is also remarkable on account of its sensibility to low strengths of cyanide. The following table shows the results obtained with a free cyanide strength of 0.042%; the total cyanide was 0.066%, and the protective alkali, 0.046% CaO.

	Silver, oz.
Ore after concentration in water	8.30
After mixing with solution	4.48
Sand from above (tube-mill heads)	5.52
Tube-mill tailing, 52%, coarser than 200-mesh	5.28
Discharge from Dorr thickener	2.72
After standing six hours pulp was pumped to Pachuca tank without addition of cyanide	2.28
After 6 hr. agitation	2.18
After 9 hr. agitation	1.96
After 18 hr. agitation	1.82

The tailing consisted of 42% slime, assaying 1.44 oz. Ag; 45% sand finer than 200 mesh, with 2.06 oz. Ag; 13% sand coarser than 200 mesh, assaying 2.42 oz. Ag. It will be seen that both in time of treatment and in strength of cyanide necessary, this ore is similar to ores containing embolite and native silver as described by Theo. P. Holt, in the *Mining and Scientific Press*, July 31, 1909. In order to check this theory, as to the form of combination of the silver, the following test was made on the suggestion of E. M. Hamilton. To the working solution nitric acid was added in excess and the mixture boiled. The resulting precipitate (silver cyanide and chloride) was removed and treated with hot concentrated nitric acid. The precipitate which was then insoluble was easily dissolved in ammonia. This established the presence of chlorides in the solution, and probably therefore in the ore, although the water used for washing on the slime-filter press contained traces of chlorides. Whether the ore also contains native silver has not been proved.

For a short time the mill and cyanide plant were operated without concentrating, and in order to effect the same extraction as obtained with combined concentration and cyanide treatment it was necessary to use a 0.15% free cyanide solution and a 30-hour treatment in Pachuca tanks. In this case it was necessary to dissolve the argentite, which in general was separated as concentrate, as well as the chloride, which yields to shorter treatment.

It has proved here, as at Copala (*Mining and Scientific Press*, June 8, 1907, p. 719) that a high protective alkalinity is necessary with this ore in order to keep down the quantity of zinc in solution; and that even with the protective alkalinity constant at 0.1% CaO it is only safe to regulate the solutions by the free cyanide test, because the variations in zinc and copper present often cause the indicated total cyanide to vary from an amount less than the free cyanide present to three times the free-cyanide strength. Under this latter condition the recourse is to increase the protective alkalinity to 0.15% CaO, and then the zinc goes down to the normal quantity;

but on account of using vacuum-filter presses, with a canvas filtering medium, it is not expedient to keep the slime permanently at this high strength.

Although it is usually stated that the zinc is precipitated from working solutions as cyanide of zinc, it seems probable here that basic zinc carbonate, at least under some conditions, is thrown down. The reaction ought to regenerate free cyanide, and this is usually observed to be the case, for the cyanide rises as the zinc decreases.

CYANIDATION OF CONCENTRATE

By A. E. DRUCKER

(March 19, 1910)

After about three years of experimental work in Korea with the Oriental Con. M. Co., in connection with the treatment of sulphide slime, and also after an 18 months' tour and study of cyaniding methods in India, New Zealand, Australia, South Africa, and the United States of America, I have come to the conclusion that the combined air-agitator and continuous leaching vat as shown in the drawings accompanying this article is the most economical and efficient system of any in use at the present time for the treatment of a high-grade slime containing gold and silver. This agitator is the result of selecting the good points of other styles I have seen in various places. What I claim as being original is the arrangement and device for keeping the bottom-filter free from slime-cake, thereby allowing the gold-bearing solution to leach through the slime and to pass the filter to the zinc-boxes, while at the same time the pulp is being aerated and air-agitated. This agitator is particularly adapted to the cyanide treatment of gold and silver-bearing sulphide slime, and in fact to any other high-grade slime where it is desirable to get the highest possible extraction in the shortest time.

These agitators may be made in three sizes: 15 by 6 ft. diam., 10 tons capacity; 25 by 7 ft. diam., 20 tons capacity; and 35 by 8 ft. diam., 40 tons capacity, all dry weight. These are the figures given for a clean sulphide slime. The consistence of the sulphide slime under treatment is about 1 to 1 by weight. All details of construction of this combined agitator and leaching vat will be found in the figures. There are four arms *F* at right angles to each other, revolving at about 6 r.p.m., and to these are attached 26 cast-iron double plow-shoes *G* equally spaced. The shoes on opposite arms are arranged to work in between, so as to keep the whole filter-bottom free from slime-cake.

The cloth filter is well braced about 6 in. from the bottom, and can neither bulge one way nor the other under pressure or vacuum. This filter-bottom consists of 3-in. pine boards *H*, bored with 1-in. holes, and placed as closely together as possible. In addition to these holes the top of the 3-in. boards are grooved so as to get the full benefit of the filtering area when the cloth is placed above and calked to the sides of the vat by means of a rope. As a

protection to the filter-cloth a $\frac{1}{8}$ -in. sheet-iron cover, bored also with 1-in. holes to correspond to the 1-in. holes below in the wood bottom, is placed on top of the cloth and secured. The filter-cloth is between, and the inch holes above should coincide with those below, as shown in the drawing. The plows *G* attached to the arms *F* can be easily raised or lowered 2 or 3 ft. by means of the lower threaded end of the vertical driving-shaft. This is important if it should be desired to stop the agitator while the pulp remains in the vat. These plows are driven by means of the worm-gear *K* beneath the vat. On stopping, the arms are raised, say, $2\frac{1}{2}$ ft.,

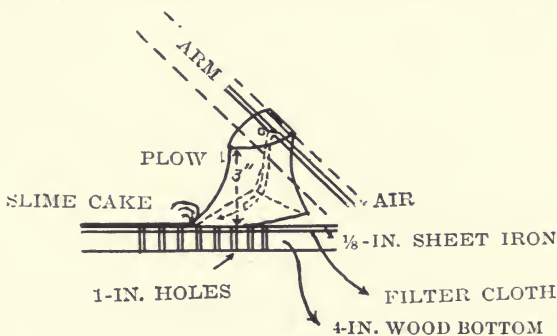

Fig. 81

and the slime allowed to settle. On starting again, the plows are set in motion and gradually lowered through the settled slime until the points just begin to touch the filter. There it is made secure by means of a clamp-wheel *M* on the threaded end of the vertical driving-shaft. The plows revolving close to the filter prevent any slime-cake from forming, thereby allowing continuous leaching from above of the gold solutions into the compartment *I* beneath the filter, and thence to clarifying presses or sand-tanks, through which the clear solution passes to zinc-boxes.

There is no trouble in lowering the arms when plow-shaped shoes are attached. I have never found any other form of shoe that would successfully work down on this heavy, thick, sulphide slime after it was once allowed to settle, especially the last layer of slightly coarser material next to the filter, which packs like cement.

An agitator of this type is particularly adapted to the treatment of heavy sulphide slime. There is always a small amount of fine concentrate that is bound to escape into an agitator from the classifiers, even though all is ground to pass a 200-mesh screen. With a sulphide, the coarser portion passing a 200-mesh screen will give serious trouble to any other form of agitator upon allowing the charge to settle, on account of being unable to work down on a cemented sulphide.

Compressed air for aerating, agitating, and softening of cake is introduced through the hollow vertical driving-shaft, and from

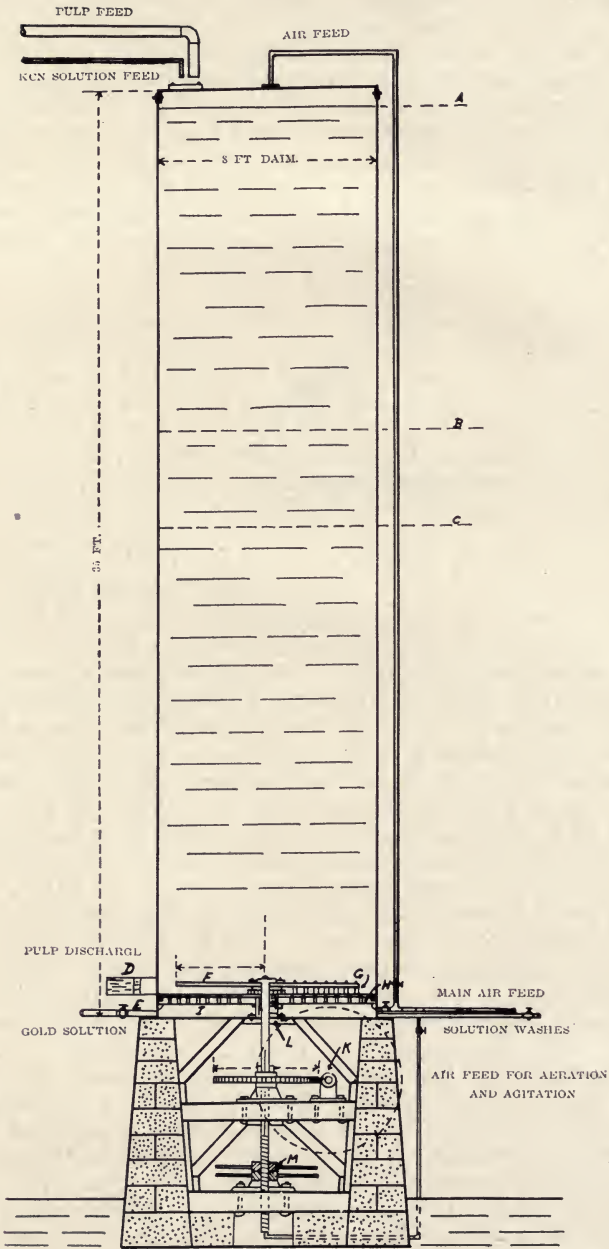

Fig. 82

the top is conveyed by means of small pipes to the points of each plow as shown. At the end of each air-jet within the plow a rubber nipple is attached, so that when air is being forced through, the nipple expands and allows the air to do its work. When the air is turned off the nipple contracts, preventing any slime from entering the pipes and clogging them. The air-connection at the bottom of the hollow shaft is made by means of a swivel and rubber hose, so as to allow a vertical movement upward or downward of the arms to which the plows are attached.

The object of forcing air beneath the cutting-points of the plows is to somewhat soften the cake, thereby helping the plows in their work. At the same time this air is being well distributed at the bottom of the vat, and bubbles up through the charge, keeping the pulp well agitated and preventing settlement of the slime. Everything seems to be actually boiling. Aeration and agitation are perfect at every point of the vat. Each agitator has a friction-clutch beneath the vat for starting or stopping the plows. With four of these vats placed in a row one main horizontal line-shaft *K* drives all, a friction-clutch being needed for each vat.

The vertical driving-shaft to which the arms are attached passes up through a stuffing-box *i* in the bottom of the vat, so as to prevent leakage of solution pulp at the entrance of the shaft. This packing-box is placed so that it can be readily tightened from beneath the vat when required. After removing the first strong cyanide solution down to about 30% moisture by means of pressure-filtering, all subsequent barren cyanide washes, if necessary, are to be forced up through the vertical driving-shaft, and out through the pipes on the arms to the points of each plow. By this means the wash is added at the bottom of the vat and works itself upward through the thick pulp, giving a perfect mixing and wash. After sufficient wash-solution has been added it is turned off, but the arms are caused to rotate, while pressure-filtering is resorted to for driving the solution through the filter to the zinc-boxes. When this operation is complete there remains about 30% moisture within the thick pulp. This slime is forced into a filter-press where it is given a weak wash, and the 3-in. cakes finally discharged as a residue with about 10% moisture.

With a 40-ton vat (8 by 35 ft.) treating clean sulphide slime, and requiring a 4-day treatment, the following power is necessary:

40-TON CHARGE

	Horse-power.
For driving short arms (intermittent power).....	1
Air agitation (15 cu. ft. air per min. at 26-lb. pressure; intermittent power)	1½
Total intermittent power	2½
Continuous power	2
Continuous power per ton treated.....	0.05

The operations can be divided as follows after all-sliming the sulphide within a tube-mill in cyanide solution, taking for example a 4-day treatment.

1. Collecting a full charge in agitator (undergoing an air agitation and leaching while filling)..... 24 hours
 2. Air-agitation and continuous leaching (cyanide solution carrying gold and silver, continuously flowing to the zinc-boxes; pulp finally pressure-filtered down to 30% moisture before washing) 36 hours
 3. Intermediate barren cyanide wash (mixing and finally pressure-filtering down to 30% moisture before sending to filter-press). 12 hours
 4. Filter-pressing, weak wash, discharging..... 24 hours
- Total 4 days

ANALYSIS OF SULPHIDE SLIME TREATED IN KOREA

No. 1 Sulphide

	Per cent.
Iron pyrite (FeS_2)	56
Galena (PbS)	36
Sphalerite (ZnS)	6
Arsenopyrite (FeAsS)	2
	100

No. 2 Sulphide

Arsenopyrite	72
Marcasite	27
Galena }	1
Sphalerite }	traces
Copper pyrite	traces
	100

The No. 1 sulphide carries from \$40 to \$50 in gold. Only a fraction of an ounce of silver is present in this sulphide. An actual extraction in bullion of 92 to 94% was obtained by my combined agitator and leaching-vat at the experimental plant in Korea during 1908. The old method of leaching No. 1 sulphide (without all-sliming in tube-mill) for 18 days in shallow vats, with strong cyanide solutions, gave an extraction of 84%. No. 2 sulphide carries from \$20 to \$30 in gold. A 16-day leach in shallow vats (without all-sliming) gives an actual gold extraction of about 70 to 75%. Upon all-sliming this sulphide in a tube-mill, and finally treating in my combined agitator and leaching-vat, the extraction was increased to 92% with only a 4-day treatment. Costs depend upon conditions, and these vary greatly in different parts of the world. In Korea our expensive item is power, while labor is cheap and efficient. A comparison between old and new methods of treating sulphides in Korea per ton of clean sulphide treated (1200 tons per month), shows: (1) Old method, 18-day leaching in shallow vats, estimated at \$2.17 to \$2.37; new method, all-sliming and tall air-agitators, estimated at \$2.75 to \$3. (2) Per ton of ore milled or concentrated (20,000 tons per month), old method, 13 to 14c. (taken from company report); new method, 16 to 17c. (estimated).

In a great many places (Australia, America, Mexico, and New Zealand), the ore is concentrated before cyaniding, and the sulphide concentrate shipped to the nearest smelter for reduction, the owners being content with high smelter and transportation charges. The smelters, however, do not pay for the whole of the precious metal.

If one realize 95% of the true assay-value he is lucky, after taking into consideration the percentage of moisture and improper sampling. Why ship concentrate to smelters that can be successfully treated by the cyanide process? The majority of gold and silver bearing sulphides can be treated on the spot at a far better profit than by shipping to the smelters.

Most sulphides (concentrate) offer little trouble to a successful cyanide treatment provided the following points are observed: (1) The ore to be treated fresh and re-ground in a tube-mill with strong cyanide solution (0.15 to 0.20% KCN) so that the product going to the agitator will all pass a 200-mesh screen. (2) To be air-agitated and aerated in the combined agitator and leaching-vat shown in the drawing. Treatment from 20 to 36 hours. (3) It is a very important point to continuously leach at the same time the pulp is being air-agitated, so that at the end of the 20 to 36-hour treatment practically the bulk of the gold and silver has been deposited in the zinc-boxes. This method gives excellent results. It not only cuts down on the time of treatment to a large extent, but also avoids the numerous washes formerly required with the old methods of agitation in one solution. (4) Keep an eye on the protective alkalinity of the cyanide solutions. Do not attempt to use cyanide solutions testing only 0.05 to 0.15% KCN and expect to get good results in a 20 to 36-hour agitation. About 0.25% in free KCN I find suitable for most sulphides. Use KCN in preference to NaCN, when air-agitation is employed. KCN gives better results at a less consumption of cyanide. (5) Do not allow the strong cyanide solution to become so foul as to become inactive. This is one of the serious troubles in treating sulphides. A newly made solution, free from reducing agents, will give the best extraction, and have the greatest dissolving power, but as it becomes older and takes up various foreign substances, which act as reducing agents, robbing the solution of its oxygen, the extraction gradually falls. The cheapest and most effective way of maintaining the extraction and overcoming this reducing action is by a thorough aeration while agitating the pulp with cyanide solution. In treating concentrate (sulphide) it is not a bad plan to make a new strong solution every six months.

DIAPHRAGM CONES AND TUBE-MILLING

By WALTER NEAL

(April 2, 1910)

Numerous references have recently been made to the invention by W. A. Caldecott known as a 'diaphragm cone'. As all of these have referred to work done on the other side of the world, a brief description of the apparatus as used in the mills of the Cia. Minera Las Dos Estrellas, and some experiments made with it as a thickener before tube-milling, will be of interest.

The apparatus is described by its inventor as a "classifier of

the conical type * * * kept filled nearly to the top with sand, and an essential patented feature of its successful operation consists of an internal serrated or notched horizontal disc-diaphragm near the bottom. '*



Fig. 83. DIAPHRAGM CONE

As used at Dos Estrellas it consists of a circular sheet-iron plate, supported toward the apex of an ordinary cone-classifier by two straps riveted to the plate, and having their ends riveted to the sides of the cone, leaving an annular space between the plate and the sides. The width of this annular space, and the height of the diaphragm above the apex of the cone, vary with the size of the cone and the tonnage and character of the pulp. So far as my experience goes these points are best determined experimentally, although with sufficient data doubtless some approximate formula could be deduced. A cast-iron plug-cock at the apex provides a means for regulating the underflow.

When starting operation this cock is closed, and the pulp is turned into the cone. Sand is allowed to collect until it is within about 10 in. of the overflow. The cock is then opened enough so that thick sand may issue at the same rate that it settles out of the thin pulp flowing into the cone.

The settled sand, on account of its thickness, issues from the spigot in a stream of low velocity but of large area. The pulp entering the cone above, drops its heavier particles, thus automatically renewing the bed, and the valve at the apex is regulated so that

**Journal of the South African Association of Engineers*, Dec. '08.

the level of the bed neither rises nor lowers. Should the bed of sand drop too low a break occurs, and thin pulp issues from the spigot, the same as in a simple cone. The remedy is to close the

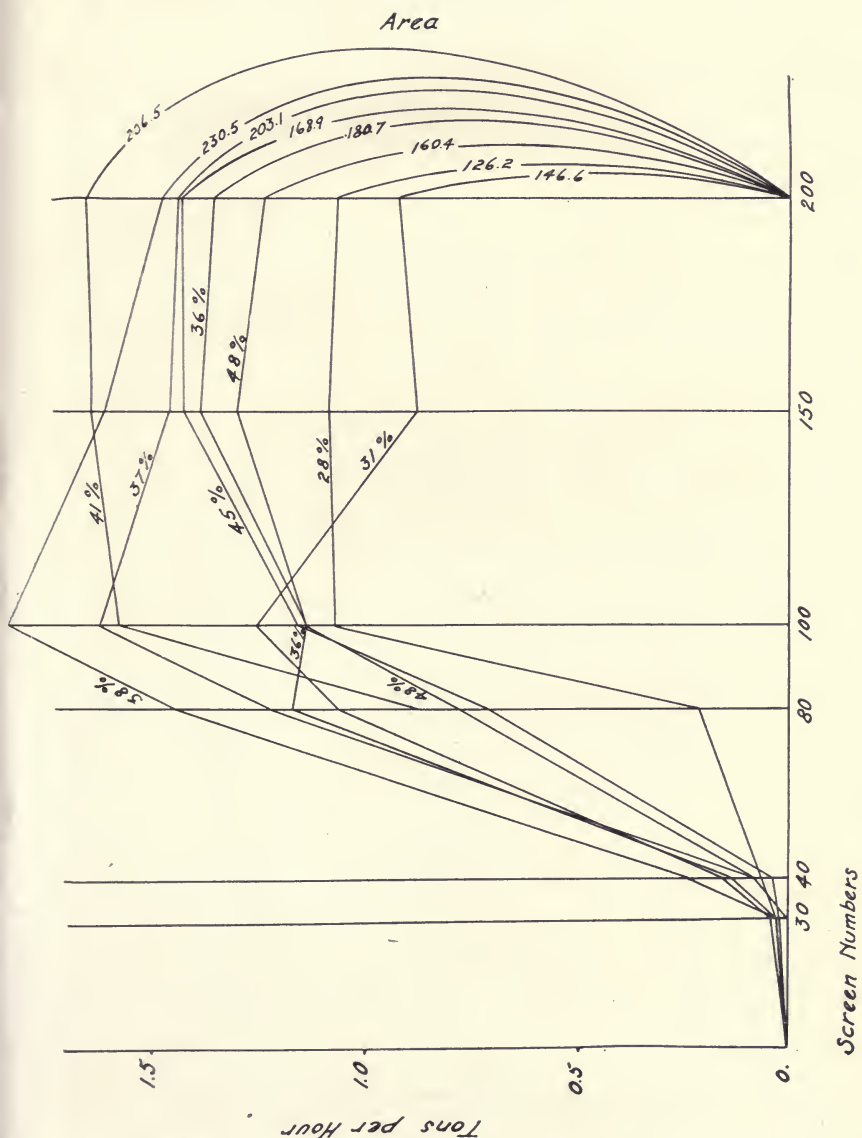

Fig. 84. TEST ON BEST THICKNESS OF TUBE-MILL FEED

cock and allow the channel to pack with sand again. Should the spigot, on the contrary, not be opened sufficiently, the bed of sand will rise to the rim of the cone and a sandy overflow will result.

It will be seen from the above that the apparatus does its best work on large cones where the level of the bed of sand has sufficient vertical variation to allow for slight fluctuations in the feed, without dropping too low and breaking through, or rising so high

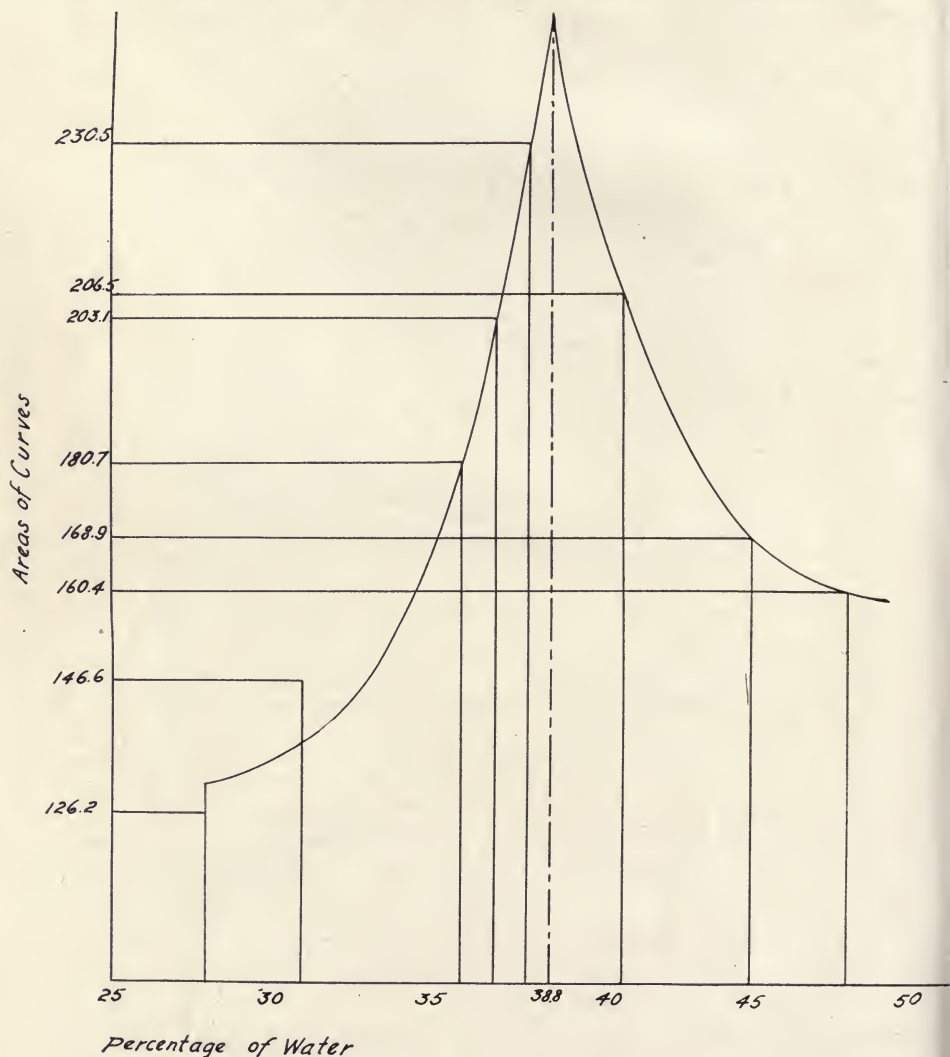

Fig. 85. TEST ON BEST DILUTION OF TUBE-MILL FEED

as to cause an overflow of sand. A steady feed is, of course, desirable. Where the fall in a mill is insufficient to allow for the installation of large cones, it is my experience that it is better to allow a sandy overflow which may be passed through a sand-return

cone without a diaphragm. On large cones, 9 ft. or more in height, but little trouble is experienced, and with the underflow once properly regulated and a steady feed established, the cone will run for

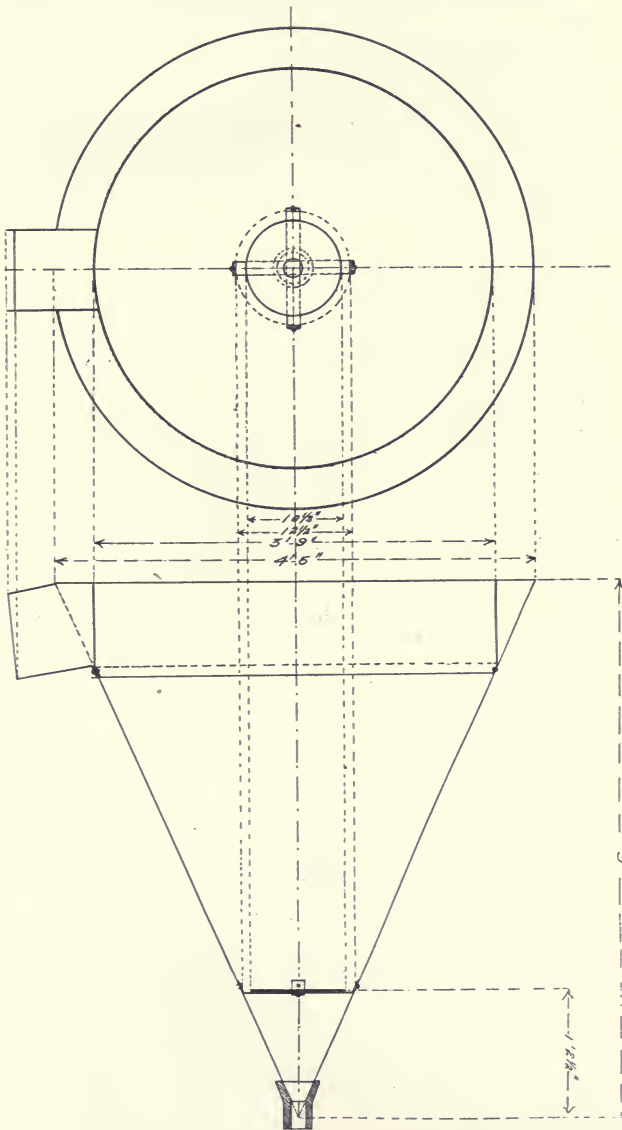

Fig. 86. FIVE-FOOT DIAPHRAGM CONE

hours, giving a slime-clear underflow and a sand-clear overflow with no attention whatever. Because of the large aperture of the underflow, nothing smaller than a gunny sack will stop it up.

The experience at Dos Estrellas has been that the diaphragm cone does better work when given a heavy feed than when given a light feed. For instance, a tube-mill thickener 8 ft. high by 7 ft. diam. did its best work (without diaphragm) with underflow bushed down to a 1/2-in. pipe-nipple and receiving 150 tons of ore per day (16 mesh) direct from the batteries, having a dilution of about 9 to 1. The same cone, when fitted with a diaphragm 16 in. above its apex, did its best work when receiving about 250 tons of the same pulp per day. The reason is that the thick sand underflow ran steadier through the larger aperture required for the greater tonnage than through the smaller one. Probably change in the proportions of the diaphragm would improve matters on the smaller tonnage.

The underflow consists of remarkably clean sand. In the case of the cone mentioned above the underflow through the 1/2-in. nipple carried from 15 to 20% through a 200-mesh screen, whereas the average underflow, after installing the diaphragm, carried from 3 to 5% passing a 200-mesh screen. This is, of course, a great advantage when thickening for tube-milling, since no one likes to pay for power to grind pulp finer than 200 mesh, while coarser sand is actually going into the slime-tanks. The underflow from the diaphragm cones contains from 28 to 30% moisture.

When the diaphragms were first installed at Dos Estrellas great grinding efficiency was anticipated on such extremely thick pulp. The results, however, were disappointing, being no better than had been obtained on pulp with 50 to 55% moisture. Experiments were then started to see where the trouble lay, and as the pulp appeared to be too thick for efficient grinding, to determine at just what dilution the tube-mill would do its best work.

The tube-mill used was of the Gates type; made by the Allis-Chalmers Co., and had an inside diameter of 5 ft. and a length of 24 ft. The effective diameter is reduced about 6 in. by the 'El Oro' liners used. The mill ran at 26 r.p.m. The thick sand from the diaphragm was fed into the mill through a small sheet-iron launder passing from below the cone to the trunnion of the mill. In order to feed the sand at varying degrees of dilution for purposes of experiment, a water hose was laid in the feed-launder, and the required amount of water allowed to run into the mill along with the sand. The mill was allowed to run long enough for conditions to adjust themselves within it, and during the experiments samples were taken at five-minute intervals of the heads and tailing. A determination of the tonnage crushed per hour was also made at the middle of each experiment by weighing the amount of wet pulp discharged by the mill in a measured time. Having the specific gravity of the tailing, the dry tonnage crushed per hour could be calculated from this.

The results of sizing tests on these samples are shown in Table 1. The figures in Table 2 were obtained by subtracting the total percentage remaining on any mesh in the tailing from the whole amount remaining on the same mesh in the heads. Thus in test

No. 1 is obtained for 30-mesh $0.5 - 0 = 0.5$; for the 40-mesh $1.5 + 0.5 - 0.5 = 1.5$; for 80-mesh $0.5 + 1.5 + 12.5 - (0.5 + 9.5) = 4.5$, and so forth. Table 3 was obtained by multiplying the percentages

Sample	Specific Gravity	Tons per Hour	On 30 mesh	On 40 mesh	On 80 mesh	On 100 mesh	On 150 mesh	On 200 mesh	Through 200 mesh
1H	1.760	4.7	0.5	1.5	12.5	33.5	35.0	1.0	16.0
1T			—	0.5	9.5	16.0	34.0	2.0	38.0
2H	1.708	4.6	1.0	3.0	28.5	19.0	28.5	3.0	16.0
2T			—	0.5	10.0	15.0	36.5	2.0	36.0
3H	1.627	5.4	0.5	3.0	32.5	15.0	33.0	4.0	12.0
3T			—	1.0	13.5	15.5	28.5	4.5	37.0
4H	1.605	5.1	—	2.0	36.0	19.5	30.5	3.0	9.0
4T			—	0.5	13.5	12.0	33.5	3.5	37.0
5H	1.594	5.1	0.5	4.5	34.0	19.0	29.0	3.5	9.5
5T			—	0.5	10.0	11.5	33.5	6.0	38.5
6H	1.546	5.4	0.5	1.5	20.0	24.0	35.0	3.5	15.5
6T			—	0.5	5.5	11.0	34.0	4.0	45.0
7H	1.489	4.5	0.5	1.0	18.5	20.0	38.0	5.5	16.5
7T			—	0.5	4.0	10.0	32.0	5.5	48.0
8H	1.453	5.0	—	2.0	27.5	21.5	34.0	3.0	12.0
8T			—	0.5	13.5	14.5	30.5	4.5	36.5

TABLE 1

shown in Table 2 by the actual tonnage per hour. It thus shows the actual amount of pulp formerly too coarse to pass through each mesh, but which was made to pass through it during the process of grinding. Table 3 supplies the ordinates for the curves in Fig. 84.

Test No	Percent Water	Tons per Hour	On 30 mesh	On 40 mesh	On 80 mesh	On 100 mesh	On 150 mesh	On 200 mesh
1	28	4.7	0.5	1.5	4.5	22.0	23.0	22.0
2	31	4.6	1.0	3.5	23.0	27.0	18.0	20.0
3	36	5.4	0.5	2.5	21.5	21.0	25.5	25.0
4	31	5.1	—	1.5	24.0	31.5	28.5	28.0
5	33	5.1	0.5	4.5	28.5	35.0	31.5	29.0
6	41	5.4	0.5	1.5	16.0	29.0	30.0	30.5
7	45	4.5	0.5	1.0	15.5	25.5	31.5	31.5
8	48	5.0	—	1.5	15.5	22.5	26.0	24.5

TABLE 2

The included areas of the curves in Fig. 84 are shown, plotted as ordinates in Fig. 85, as giving some sort of a basis of comparison of crushing efficiency.

These tables clearly show the ideal dilution to be in the neighborhood of 39% moisture. It is surprising to note what a marked

difference in grinding, a comparatively small difference in dilution makes, and it immediately suggests that not enough attention has been paid to this point in the past. To bring the matter home in another way, it may be stated that approximately three tube-mills working on 39% pulp will do the work of four mills working on 36 or 48% pulp.

It is probable that the 'critical dilution' would vary at different plants on account of different ores and various makes of tube-mills, but certainly the matter is worth investigating. Undoubtedly it is

On 50 mesh	On 40 mesh	On 30 mesh	On 100 mesh	On 150 mesh	On 200 mesh
0.024	0.071	0.212	1.06	1.08	1.06
0.046	0.161	1.06	1.24	0.87	0.32
0.021	0.135	1.16	1.13	1.38	1.35
—	0.077	1.22	1.61	1.45	1.43
0.025	0.228	1.45	1.83	1.60	1.47
0.027	0.081	0.865	1.57	1.63	1.65
0.022	0.045	0.697	1.15	1.42	1.42
—	0.075	0.775	1.13	1.30	1.23

TABLE 3

more than a coincidence that V. B. Sherrod, experimenting with tube-mills at the Guerrero mill, Real del Monte, finds that "the grinding efficiency increases with the percentage of solids in the feed up to about 55 or 60%."* My acknowledgments are due to A. Quartano for his skill and care in carrying out the experiments herein described.

IMPROVEMENTS IN THE CYANIDE PROCESS

By BERNARD MACDONALD

(May 28, 1910)

The fact is generally recognized that the only important improvement made in the cyanidation of gold and silver ores during the last five years has been in the mechanical manipulation of the ore-pulp during treatment, and in the methods of recovering the metals brought into solution, and that the chemistry of the process has remained practically unchanged. The sum of the mechanical means and methods that have been developed and improved during this period, omitting the numerous details of manipulation, may be set down as: (1) Stamping through coarse battery screens. (2) Classification and dewatering of the battery product into sand and slime. (3) Fine grinding (sliming) the sand. (4) Dewatering (thickening) the slime-pulp. (5) Treatment of the slime in high tanks by air-lift agitation. (6) Recovery of the solution from the

**Informes y Memorias del Instituto Mexicano de Minas y Metalúrgia*, December 1909.

treated pulp by filter-pressing. (7) Precipitation of the gold and silver from the solution by zinc-dust.

In Mexico where the tonnage of silver ore treated by stamp-milling and cyanidation is greater than in all other mining regions combined, and where the largest part of this tonnage is of very low-grade ore, every new design promising greater economy and efficiency has been adopted and used.

The high royalties charged by proprietors of patent devices used in the processes have furnished the incentive if not imposed the duty upon all mining engineers charged with the design of new plants to evolve other methods equally as effective to accomplish the same purpose, hence the number of filter-presses and variety of design of other equipment now on the market. The result is competition and a choice of machinery that makes for cheaper and more efficient plant, with correspondingly greater economy of operation, making possible the profitable treatment of lower grade ores.

A recent improvement in tanks for the treatment of slime-pulp is shown in the accompanying figures, for which United States Patent No. 948,766 and Mexican Patent No. 9948 have been issued. I believe this tank to be a great improvement over any hitherto used in the treatment of the slime-pulp of gold and silver ores. This tank, with its special equipment, is known as the 'Parral' tank, a sectional view of which is seen in Fig. 88. The main improvements in this tank are: (1) The division of the tank-bottom into two or more pockets or compartments of inverted conical or pyramidal form, made of wood or steel partitions. (2) A charge-pipe extending from the top of the tank and terminating in nozzles placed at the apex of the bottom-compartments through which the pulp-charge entering the tank passes, and is delivered under the pressure of the hydrostatic head due to the height of the charge-pipe over the pulp-level in the tank. (3) Two or more transfer-pipes set at or near the sides of the tank, and extending from the bottom to the top of the tank, having the lower ends resting on the tank-bottom, but open, so as to admit the entrance of the pulp which settles to the bottom of the tank for transfer through these pipes and delivery on the top of the tank-charge.

These methods of charging the pulp into the tank and of transferring to the top of the charge the heavier particles as they settle secure an intimate admixture of the cyanide solution and the pulp-particles which is necessary for bringing the contained metals into solution. This type of tank equipment makes it possible and even desirable in large milling plants to use treatment-tanks each having a holding capacity of 300 to 400 tons of dry pulp, for these tanks may be made of any diameter and any height warranted by local conditions, as the full charge of pulp can be treated with efficiency and economy equal to that in the ordinary small tanks.

In operation the tank receives the charge of pulp for treatment through a charge-pipe of any suitable diameter which may be placed within or without the tank, according to local conditions. The pulp

passing downward through this charge-pipe is delivered through branches terminating in nozzles, one nozzle at the apex or bottom of each of the two or more pockets or compartments built on the tank-bottom, as shown in the figure. The pulp being thus charged enters these compartments through the nozzles under hydrostatic pressure which creates sufficient agitation to prevent settlement of

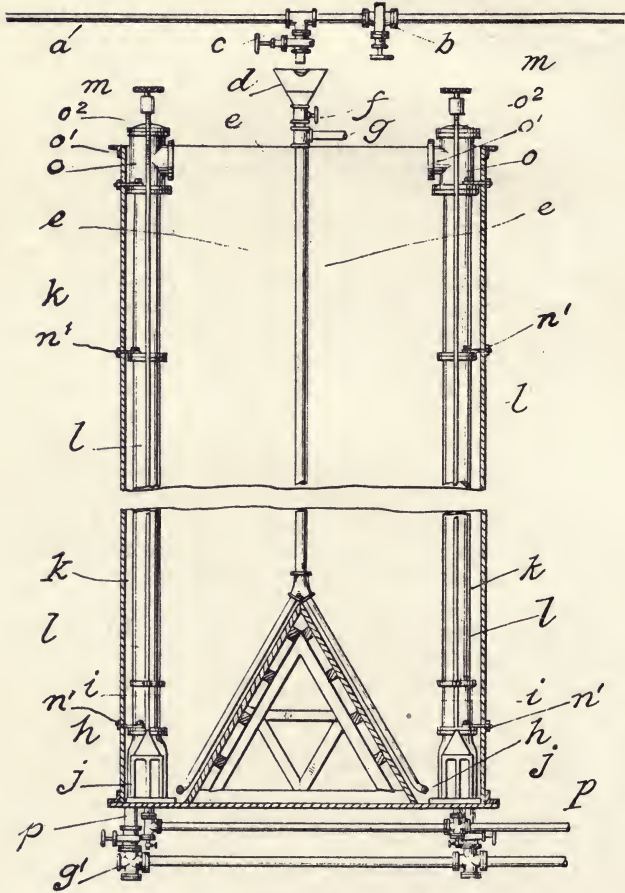

FIG. 87

the pulp-particles on the bottom of the tank. However, to prevent the possibility of pulp settlement on the bottom of the tank, provision is made for the admission of compressed air or cyanide solution under pressure at the bottom of these compartments through the same nozzles. This gives any desired amount of agitation. The charge-pipe at its intake at the top of the tank is provided with a receiving hopper, or funnel, having a screen bottom. The chemicals necessary to bring the solution contained in the pulp-charge

up to working strength are weighed and placed in this hopper periodically, as required, and the pulp being charged into the tanks flows over and through them, dissolves and carries them in solution with it as it is injected into the bottom of the tanks through the terminating nozzles of the charge-pipe.

The advantage of this method of under-feeding the pulp which is charged into the tank, and having it intimately mixed with the required strength of chemicals freshly brought into solution, as compared with the open feed on the top of the charge, which allows the heavier pulp particles to settle out of the associated solution to the bottom, leaving the latter on the top, is apparent.

This treatment-tank is designed to receive its charge of pulp directly as delivered from the pulp dewatering (slime-thickening)

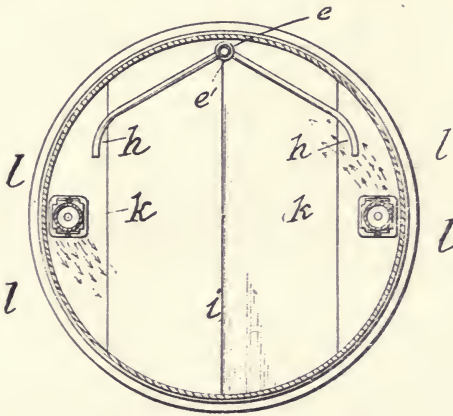

Fig. 88. PARRAL TANK

tanks, and thus it fills the functions of a collecting and treatment tank simultaneously. When the tank has received its full charge the agitation necessary to complete the treatment by bringing the valuable metals into solution, is begun. This is effected through the two or more transfer pipes referred to, one for each of the compartments into which the bottom of the tank is divided. These transfer pipes are firmly supported on the bottom of the tank by open foot-pieces of suitable design. Through these foot-pieces compressed air is introduced to the transfer pipes in an upward current, which effects the rapid transfer of the pulp from the bottom of the tank, and its delivery at the top of the charge. The top or delivery ends of the transfer pipes are fitted with tees, or ells, placed at such an angle that their delivery outlets are in the same direction and circumferential to the sides of the tanks. The force of the pulp thus being delivered on the top of the charge imparts to it a whirling motion which carries the pulp particles in a spiral course around the tank in their settlement toward the bottom. When they reach and settle into the apex of the bottom compartments

they are again picked up and carried through the transfer pipes and delivered on the surface of the charge, and the agitation is thus continued until the treatment is complete. It is reasonable to believe that this whirlpool motion disentangles the heavier pulp-particles from the colloidal material in the pulp-mass in which they may be imprisoned, exposing them to freer contact with the chemical solutions, and thereby hastening the extraction of the metals they may contain. It is also considered that a plurality of transfer pipes of smaller diameter can be operated with greater economy than one large pipe of equal area. The reason for this belief lies in the fact that compressed air, in order to be effective as a lifting agent in a submerged pipe, must form in discs, the circumference of which must touch the sides of the transfer pipes and thus travel upward through it, while if the transfer pipe be of large diameter the compressed air will rise as bubbles through its centre and have no more lifting effect on the pulp contained therein than if a rod were rammed up through the centre of the pipe. The bubbles of compressed air merely take a zigzag upward course through the pulp which fills the column, leaving it to remain balanced in equilibrium with the pulp or liquid in the tank outside the transfer pipe. Of course, this equilibrium can be overcome by the injection of a sufficiently large volume of compressed air to fill the transfer pipe so that air may form in discs extending across the pipe, no matter what its diameter may be, but this is wasteful and expensive.

The lifting action of compressed air in a submerged pipe-column is effected by a complete intermittent cut-off or separation of the liquid in the column, from the liquid outside it, by air discs, as described. Separate bubbles, no matter how many, rising through the transfer pipes have no more lifting effect on the pulp contained than the ascending bubbles in a glass of champagne has on its contents. To be effective for this purpose the air must form in discs wholly across the transfer pipe, in which form they act as the piston of a pump, each disc separating and completely cutting off a certain amount of pulp from the mass in the tank outside and carrying this amount with it as it rises to the top. The number of such discs formed per minute is analogous, in lifting effect, to the number of piston-strokes of a pump.

As stated before, one of the main advantages of the 'Parral' tank is that the apparatus with which it is equipped makes it possible and even desirable to build it of larger dimensions than would be commendable in the use of one central transfer pipe. A tank 15 ft. diam. (which is the limit for a treatment tank with one transfer pipe) by from 45 to 47 ft. high is the average of the largest treatment tanks in general use, and has an approximate holding capacity under ordinary consistence of pulp of 100 tons of dry slime, while a tank of equal height and 30 ft. diam. would have a holding capacity of 400 tons of dry slime of similar consistence. It will be readily seen how the larger tank with four bottom-compartments, or pockets, and four transfer pipes, placed around the sides with their intake ends opening into the apex bottom of these

pockets would effect equally as good agitation and treatment as would be the case in a tank of 100 tons capacity with one air-lift transfer pipe, while the economy in extraction and operation per ton would be an item of considerable importance.

METHODS OF PULP-AGITATION

By LLOYD M. KNIFFIN

(June 4, 1910)

It is good to see that more attention is being paid to the question of agitating pulp during cyanide treatment and that the metallurgist is not now limited to centrifugal pumps and arm agitators. The waste of energy with these methods is enormous. At one plant 40 hp. are required to agitate a pulp containing 100 tons of dry slime, and power there costs 3c. per horse-power hour. The proper choice of an agitating device depends upon the amount of aeration that the ore requires during treatment, and, therefore, upon the form in which the silver is combined, because the gold usually submits to any treatment required for the silver, and for this reason no one system is applicable to all ores.

In the following analysis I have tried to arrange the various systems in the order of their aerating capacity, for it should not be forgotten that length of treatment required with any system must enter into the question of cost. A system which would extract the silver from an ore in half as much time as some other system, would have an even chance, though it required twice as much energy.

If the ore only requires that fresh molecules of cyanide be brought continually to the particles of metal, and that the air which is included in the solution be sufficient for the reaction, there is no system at present better than the arm agitators, raised a few feet above the bottom of the tank, and driven at 800 linear feet per minute. At this speed no difficulty is experienced in starting, because during operation the pulp is picked up far enough below the arms to leave space for the sand to settle when the arms are stopped. This method is giving excellent results on many Mexican silver ores, but other ores require a varying amount of aeration. For these other systems of agitation must be used. As one means, the centrifugal pump in conjunction with arms does the work, and the pulp often contains as much as 2% atomized air which is discharged on standing. The disadvantages of high cost of operation, and wear on linings, however, usually prohibits its use. By introducing compressed air into the suction more aeration may be obtained with less expenditure of energy.

The Pachuca system is the cheapest in operation of all that have been devised. A pulp containing 100 tons of dry slime and 150 of solution, can be treated with $4\frac{1}{2}$ hp. This is cheap work, but as an aerator the Pachuca tank is not in the first class, as the pulp usually contains little absorbed air. Most of the air used for

agitation escapes as large bubbles at the top of the column-pipe, and does not come in contact with the ore. The expansion of this large quantity of air abstracts heat from the charge. Also Pachuca tanks as at present built leave room for a large amount of sand to accumulate on the sides of the cone, which does not get agitated, and the circulation takes place in a limited cross-section. When the tank is emptied part of this sand slides out through the discharging pipe so that its true amount is not really known. Where Pachuca tanks are not required for such aerating function as they can perform they should not be installed, because they present the disadvantage of introducing air that is not available for treatment, but from which carbon dioxide enters the solution and precipitates and wastes the lime. Part of the calcium carbonate formed is deposited on the canvas of the filter-presses, if these are employed, and in this way makes an unnecessary cost for acid-treating. Herein lies a hint for selecting an agitator, namely, employ that system which will give the proper amount of aeration but no more, as an excess will be expensive.

The Hendryx system gives good aeration, and on one ore is doing more rapid work than the Trent. This result is principally due to the use of the apron, around the column-pipe, whereby a new quantity of pulp is being continually brought into contact with the atmosphere. It might be of interest that this apron has been used at one plant on Pachuca tanks, and it is deserving of an extended trial on silver ores in Mexico. The principal disadvantages of the Hendryx agitator are: high cost of installation, high cost of operation, 18 hp. per 100 tons of dry slime, and cost of wear of the moving parts.

Next in order, as an efficient aerator, I would put the system employed at the Pinguico mill at Guanajuato, Mexico. There the treatment-tank is equipped with arms for agitation and an air-pipe with a coupling, to allow for rotation, is taken down the shaft and out upon the arms. Small vents let the air escape, and the motion of the arms breaks it up and gives intimate contact of the pulp with the air. The amount of air used is thus easily controlled.

The Trent agitation system is one in which the pulp is taken from the top of the charge and pumped through arms which revolve near the bottom, due to their reaction from the force of the flow. This gives excellent aeration. The air if admitted through the centrifugal pumps gets thoroughly atomized and uniformly mixed with the pulp. The quantity of air can be regulated so that a small excess will be evolved gradually over the whole top of the charge. The disadvantage in the use of centrifugal pumps is with their low efficiency. Also, as many ores admit of treatment with a pulp of heavy consistence (sometimes one of solution to one of ore), it is hard to see why the sand would not reach the top of the charge and then the wear on the pumps would have to be contended with. Per 100 tons of dry slime, 12 hp. is required for this method. The pulp contains 3% of free air in the tank. The Just process seems to employ an excellent principle, although it has not been tried long

enough to prove it thoroughly. Both this and the Trent agitator possess the advantage of being suitable for installation in existing tanks with only slight modifications. In the Just system a false-bottom of patented porous brick is laid, which supports the charge. Air from a rotary blower is forced beneath the brick and finds its way through the pores. In this way it becomes very finely divided and agitates the charge uniformly. It is claimed that pulp 9 ft. deep can be agitated with 5 lb. of air. If the mechanical difficulties of holding the brick securely, and keeping the pores open, can be overcome this process ought to have a wide application, as many silver ores need all the aeration possible. Where it is necessary to carry a high protective alkalinity it might be necessary to acid-treat the bricks, which would be a troublesome operation.

Some plants are now making steam for the purpose of heating the charge during treatment. The condensation of this steam dilutes the charge and decreases the quantity of water that can be used for washing on the filter-presses. The use of pre-heated air for the agitation would overcome these difficulties, and offers a good field for investigation. For overcoming the difficulty in the use of air in treatment-tanks, namely, the precipitation of the lime, an apparatus using calcium oxide or other means for removing the carbon dioxide from the air before compression might be a valuable adjunct. Some of the foregoing remarks may meet with objections, but they are open to discussion. They may help to clarify a subject which is more unsettled than any other branch of cyanidation at present.

ASSAY OF GOLD-SILVER CYANIDE SOLUTIONS

By THEO. P. HOLT

(June 11, 1910)

Many methods have been published for the determination of gold and silver in cyanide solutions, which with proper care will give reliable results. Most of these, however, fail to meet the requirements of speed, accuracy, and a minimum of attention, desired by the cyanide chemist. In general, they require three operations: (1) a precipitation or evaporation of the measured solution; (2) a fusion or scorification of the product, and, (3) a cupellation of the resulting lead button. The second operation is obviated by modifications of Chiddey's well-known method, and the schemes outlined by William Magenau* and Mr. Barton† under most conditions are very satisfactory. In connection with experimental work at the Utah School of Mines and elsewhere, I have had occasion to test these methods on a large variety of solutions. I find that it is best to omit the zinc-dust entirely and precipitate the precious metals along with the sponge lead on a square of aluminum foil. Because of the position of aluminum in the electromotive series of the metals, it is a more effective precipitant in an acid solution than zinc. It also readily replaces lead from solution, the lead forming a convenient collector for the small amount of gold and silver

present. The process as outlined below permits of direct cupellation, is reliable, and requires little attention.

Take from 5 to 10 assay-tons of solution in a beaker, place on a hot plate and heat almost to boiling. Add from 15 to 20 c.c. of a saturated solution of lead acetate, a 1½-in. square of aluminum foil, and 10 to 15 c.c. of strong hydrochloric acid. A heavy white precipitate of lead and silver chlorides appears at this point, but passes again into solution as the metals are deposited. Leave the assay on the hot plate until the solution clears up and the lead sponge has all collected on the aluminum. Decant the solution, pressing the water out of the lead sponge with a rubber-tipped stirring rod, and transfer the assay to a 2½-in. square of lead foil. Take out the aluminum square, which will be found to separate readily from the lead, and roll the sponge with a round bottle to free from moisture. Fold up into a convenient form and drop into a hot cupel. The aluminum sheet should be $\frac{1}{16}$ inch or more in thickness, otherwise small pieces may become detached and remain with the lead sponge, causing the cupellation to spit. The assay requires very little attention. The re-agents are all added at one time and while the sponge may be ready for cupellation in 20 minutes, it may remain for an hour or more should the assayer be busy with other work.

I have tested the method on a large variety of solutions, and find that the losses are less than commonly occur in cupellation. A few examples from my notes may be of interest here.

No.	Solution assay.		Residue loss.	
	Au (mg.)	Ag (mg.)	Au (mg.)	Ag (mg.)
1A	0.17	5.19	0.00	tr.
1B	0.165	5.18	0.00	tr.
2B	0.835	25.14	0.00	0.06
2C	0.85	25.07	0.00	0.04
2D	0.84	25.38	0.00	0.06
2E	0.84	25.09	0.00	0.04
3A	1.73	50.56	0.00	0.05
3B	1.73	50.62	0.00	0.00
3C	1.71	50.20	0.00	tr.
3D	1.69	50.47	tr.	0.56

The above assays were made on pipette measurements of a standard solution. The residue loss was determined by a fusion on the evaporated solution and the aluminum foil. The loss during cupellation varied from one to two per cent, but since it affected the assays much alike it does not appear in the results.

**Mining and Scientific Press*, April 14, 1906.

†*Mines and Minerals*, April 1908.

INDEX

	Page		Page
Aaron, C. H.	63	Aldrich Triplex Pump	204
Acetate of Lead	14	Alkalinity, How Determined ..	229
Of Lead, Function of	234	All-Sliming	293
Acid Refining of Zinc Precipitate	278	Amalgam Plates with Iron Bar. .	72
Regeneration of Solutions,		Amalgamating Plates, Removal	
Tests on	341, 352	of	234
Acidity in Cyanide Solutions..		Amalgamation	46
	171, 172	Preceding Cyanidation	63
Action of Bromo-Cyanide on		Ammonium Per-Sulphate	313
Iron Sulphide and Metallic		Analysis of Concentrate at Gold-	
Iron	230	field	54
Of Caustic Potash	288	Of Crushing Machines	123
Of Crushing Rolls	124	Of Ore	10
Of Ferricyanides	175	Of Portland Ore	89
Adair-Usher Process	243	Of Sulphide Slime	388
Adaptability of Cyaniding to		Anderson, Isaac	352, 355
Ores	170	Annual Cyanide Letter of Al-	
Aeration	321	fred James	372
Africa, Costs in	235	Application of Cyanide Process. .	170
Decantation in	243	Arbuckle Process	367
African Stamp Capacity	235	Argall and Greenawalt	86
Agitating Arms	401	Argall, Philip	64, 86, 106
Pachuca Tanks	60	Argentite	10
Agitation	236	Treatment of	176
At Candlestick Mill, Korea..	222	Arm Agitator	401
By Compressed Air	210	Ashanti Goldfields	339
By Hendryx System	402	Assay of Cyanide Precipitate..	326
By Trent System	402	Of Gold-Silver Cyanide Solu-	
Of Pulp, Methods of	401	tions	403
Agitator and Filter Combined..	225	Of Solution at El Oro	80
And Leaching Vat Combined. .	384	Of Telluride Ores	90
And Vacuum Filter Combined	192	Assaying of Vat Sand	16
Brown	60, 365	Associated Northern Mine, Ore	
Brown Type of Laboratory..	290	Treatment at	82
For Cyanide Tests	278	Auriferous Orthoclase	382
For Treating Concentrate ...	384	Auro-Cyanide, Assay of	326
Leaching Construction of ...	385	Treatment of	19, 322
Mechanical	16	Australia, Flotation Process ...	235
Air Agitation and Continuous		Automatic Linings	114
Leaching	384	Sampler	304
And Power Required to Oper-		Tripper	14
rate Pachuca Tank	213	Auxiliary Filter	46
Alarm, Electric	304		
Albu, George	115	Babcock and Wilcox Boilers ...	9
		Baildon, Rivers R.	247

	Page		Page
Ball Pulverizers	29, 43	Butler, J. C.	234
Banks, E. G.	111	Butters & Co., Chas.	165
Barrel Chlorination	312	Butters Centrifugal Pumps ...	12
Barry Filter	237	Filter	16, 62, 237
Patent Tube-Mill Lining	111	Filter, Time of Operating ...	18
Base Metal Salts, Interfering:..	171	Filtering, Cost of	206
Belt Conveyors	10, 14, 159	Plant, Virginia City	50
Benguet, P. I.	380	Butters & Mein Distributers.13,	296
Best Percentage of Dilution of		Butters-Cassel Filter	115
Pulp in Tube-Milling	395	Calaverite	88, 105
Bismuthinite at Goldfield	153	Caldecott, W. A.	70, 329
Bisulphate of Sodium, Use of..	311	Cams, Blanton	159
Black Hills, South Dakota	303	Candlestick Mill, Korea	220
Blaisdell Company	110	Capacity of Pebbles in Crushing	108
Excavator	14, 15, 159	Of Ridgway Filter	238
Distributor	159	Cause for Failure of Leaching.	295
Black Oak Mine	198	Of Brittle Zinc	276
Blake Crushers	89	Caustic Potash, Action of	288
Static-Electric Process	106	Cement Tables	159
Blanton Cams	159	Centrifugal Pumps, Butters ...	12
Boericke, W. F.	231	Pumps, Jackson	19
Boulder, Colorado	84	Pumps, Morris	203
Boss, M. P.	122	Pumps, Rand	332
Boston-Sunshine Mill	303	Pumps, Wheeler	9
Bosqui, F. L.	152, 201, 274	Challenge Feeders	12
Briquetting Precipitate	249	Character of Cripple Creek Ores	85
Brittle Zinc	274, 275	Of Crushing Devices	128
Broken Hill, Flotation at	243	Of Lubricants	24
Bromo-Cyanide	87	Of Ore	10, 21
Action on Pyrite and Parti-		Of Tonopah Ores.....	201
cles of Iron	230	Charging Agitator Vats	16
Effect of Presence of Lime..	231	Chemical Reactions in Cyanida-	
In Australia	316	tion	171
Process, Chemistry of	250	Chemicals, Consumption of..20,	207
Solution, Making	227	Chemistry of the Bromo-Cyano-	
Testing	228	gen Process	250
Bromo-Cyaniding of Gold Ores.	226	Of the Cyanide Process ...	171
Brooks, Huxley St. J.	302	Chilean Mills	124, 131,
Brown, F. C.	210		239, 245, 246
Brown, Joseph Rodney	120	Chloride of Silver	10
Brown Agitator	117, 365	Chlorination at Goldfield	155
Laboratory Agitator	290	Barrel	312
Lining, Invention of	120	Practice	49
Vat, Cyanidation with	60	Versus Cyanidation at Crip-	
Browne, R. Stuart	39, 275	ple Creek	86
Bucket-Elevator Wheel	12	Chlorine, Generation of	155
Burt, E.	76, 110	Christy, S. B.	175, 287
Burt Filter	76, 239		

	Page
Chrome Steel Shoes and Dies..	12
Clarifying Wash Water with Lime	253
Clark, A. J.	275
Classification	13
Classifiers, Cone	12, 329
Dorr	157, 206, 364
Classifying and Dewatering Pulp	364
Claudet, A. A.	372
Clean-Up	244
Clevenger, G. H.	278
Coarse Gold, Saving	64
Cocoa-Matting	308
Cogswell, C. V. R.	365
Collection of Sand for Cyanid- ing, Continuous	329
Collector Vat	309
Collins, Edgar A. ..40, 50, 153,	302
Combination Mill, Goldfield..51,	152
Mine, Goldfield	40
Combined Agitator and Leach- ing Vat	384
Agitator and Vacuum Filter. 192, 225	
Comparative Cost of Cyaniding	150
Comparison of Filter Pressing and Decantation	366
In Treatment	235
Of Various Filters	370
Of Wet and Dry Methods ...	47
Compressed-Air Agitation	210
Comstock Lode, Yellow Jacket Mill	165
Concentrate, Cyanidation of ..	190,
318, 384	
Goldfield, Analysis of	54
Concentration	243
At Goldfield	56
Concentrator Vibrations	13
Wilfley	12, 13, 160
Concheno, Chihuahua, Mexico..	169
Concrete Mortar Foundations..	264
Condensation of Steam	9
Condensers, Edwards	9
Cone Classifiers	12, 302, 329
Conical Tube-Mill	105

	Page
Consistence of Tube-Mill Feed, Test of	391
Constantan Couple	94
Construction, Details of Pachu- ca Tank	215
Mill	306
Of Hunt Filter	216
Consumption of Chemicals..20,	207
Of Cyanide	163, 247
Of Pebbles	206
Of Zinc Dust	205
Continuous Collection of Sand for Cyaniding	329
Filter, Oliver	333
Sand Collector	309
Slime Filter	194
Vacuum Filter	216
Conveyor, Robins	159
Copper and Lead Ores, Effect of	342
Corrigan and McKinney	169
Cost of Butters Filtering	206
Of Cyaniding	148, 149
Of Cyaniding at Guanajuato.	170
Of Cyaniding at Liberty Bell Mill	148
Of Filtering	206
Of Filter-Pressing	204
Of Milling at Combination Mill	55
Of Mining and Milling at Yel- low Jacket	166
Of Roasting Telluride Ores..	92
Of Slime Treatment at Home- stake	209
Of Treatment at North Star Mine	335
Of Tube-Milling	205
Relative, Gravity <i>v.</i> Pump Filling	83
Costs at Dos Estrellas	120
At Great Boulder	236
At Ivanhoe	236
At Rosario Mine, Honduras..	256
At Silver Peak Mill	272
In Africa	235
Crimmann, O.	121
Crimped-Wire Screens	159
Cripple Creek, Colorado ...	84, 88

Page	Page
Chlorination <i>v.</i> Cyanidation. 86	Plant, Silver Peak Mill 269
Ores, Character of 85, 312	Practice in Korea 220
Processes at 312	Practice San Prospero Mill, Guanajuato 158
Crookes, Sir W. 73	Precipitate, Assay of 326
Crowe, Thos. B. 312	Process, Improvements in ... 396
Crown Reef, Tube-Mill at ... 242	Sodium at San Prospero Mill. 163
Crusher, Gates 10	Solution, Crushing in ... 12, 160
Crushing Capacity of Pebbles.. 108	Tests, Agitator for 278
Devices, Character of 128	Cyaniding, Adaptability to Cer- tain Ores 170
Dry 43	After Amalgamation 142
Energy Expended in 24	At Desert Power & Mill Com- pany's Mill 149
In Cyanide Solution...12, 63, 160	At Grass Valley, California.. 231
Machines Analyzed 123	At Pinguico Mill 150
Ore 43, 122, 239, 363	At Silver Peak, Nevada 266
Ore, Economy of Power in.. 20	Chemical Reactions in 171
Rolls, Action of 124	Comparative Cost of 150
Cuprous Chloride for Determin- ing Gold and Silver in So- lution 175	Concentrate at Taracol, Korea 318
Curves of Extraction, San Pros- pero Mill 162	Costs at Guanajuato 170
Of Solubility 161	Costs at North Star Mine ... 335
Temperature 100, 101	Silver Ore in Honduras 253
Custom Mill Plant 198	Silver Ores, Variations of ... 284
Cyanicide, Iron as a 231	With Lead Acetate 246
Washing Out 380	Cyanogen Bromide 87, 226
Cyanidation at Mercur, Utah.. 256	Iodide 312
In Mexico 167	Cylindrical Rollers 132
In Nevada 39	Daily Testing and Assaying ... 16
Of Concentrate 384	Daly Reduction Company's Mill 142
Of Fine and Coarse Gold 63	Decantation at Ferreira 244
Of Silver Ores 178, 282, 382	Compared with Filter Press- ing 366
Progress in 233	In Africa 243
Sliming Ore for 37	Process 114
Versus Chlorination, Cripple Creek 86	Slime Plant 310
With the Brown Vat 60	Definition of Slime 293
Cyanide, Consumption of 247	Deformation of Ore Particles in Crushing 25, 26, 27
Costs 148, 149, 150	Dehne and Moore Filters Com- pared 377
Extraction, Percentage of ... 20	And Vacuum Filters Com- pared 372
Filter, Burt Rapid 76	Filter-Press 82, 369, 376
In the Battery 63	Delster Table 157
Letter, James' Annual 362	De Kalb, Courtenay 35
Loss of 247	Del Mar, A. 150
Mill in Mexico, Recent 143	
Notes 316	
Of Sodium 142	
Plant, Home-made 231	

Page	Page		
Dern, George H.	303	Eagle-Shawmut, Ore Roasting at	44
Desert Mill	9	Eastman, B. L.	231
Mill, Flow-Sheet	11	Economy of Power in Crushing Ore	20
Mill, Millers, Nevada, Costs at	149	Edwards Condensers	9
Ores, Treatment of	45	Furnace	44
Design of Extractor-Houses ...	235	Effect of Litharge	189
Determination of Alkalinity ...	229	Of Graphite	336
Of Temperature	93	Of Lime in Presence of Bromo-Cyanide	231
Determining Gold and Silver in Solution with Cuprous Chloride	175	Of Lime on Solubility of Gold and Silver	188
Dewatering and Classifying Pulp	364	Electric Alarm	304
Diaphragm Cones and Tube- Milling	389	El Oro Mining & Railway Com- pany	76
Spitzkasten	364	El Oro, Filter Press at	77
Diehl Process	226	Ores	37
Difficulties Encountered	372	Ribbed Plate	138
Disadvantage of Pachuca Tanks	402	Solution Assays	80
Disc Excavator	14	Tube-Mill Lining	120, 240
Discharge, Peripheral	242	El Sotol Mine	60
Discharging Cake, Experiments in	18	Energy Expended in Crushing.	24
Discovery of Telluride Ores ...	84	Enriched Wash-Water, Disposi- tion of	280
Dissolving Power of Regene- rated Solution	344	Errors in Estimating Gold Solu- tion	372
Distributer, Blaisdell	159	Excavator, Blaisdell	14, 159
Butters & Mein Type ...	13, 296	Excessive Use of Lime	234
Dixon Pump	233	Experiments at Cripple Creek..	312
Dos Estrellas, Costs at	120	For Laboratory with Funnels	108
Mill	110, 118	In Discharging Cake	18
Milling at	394	In Roasting Telluride Ores..	88
Treatment of Precipitate at..	248	On Effect of Lead and Copper Ores	342
Value of Ore	118	With Telluride of Gold	48
Dorr, J. V. N.	303	Experimental Roasting	93
Dorr Classifiers	157, 206, 259, 303, 364	Extraction at San Prospero Mill	163
Driscoll, George E.	253	By Cyanide, Percentage of... Curves, San Prospero Mill...	20 162
Drop of Stamps	12	Houses, Design of	235
Drucker, A. E.	190, 220, 384	On Goldfield Ores	58
Dry and Wet Methods, Compar- ison of	47	Percentage of, Combination Mill	53
Crushing	43	Eye, C. M.	246, 380
Dump Material in Korea, Treat- ment of	379	Failure in Leaching, Cause of.	295
Duncan, G. A.	146	Feeders, Challenge	12
Durango, Mexico	168		
Duty of Stamps	12		

	Page		Page
Pryce	308	Flux for Auro-Cyanides	250
Ferreira, Process at	244	For Precipitate	322
Ferricyanides, Action of	175	Foote, Arthur De Wint	111
Fery Pyrometer	93	Forwood-Down Pans	82
Filter, Barry	237, 369	Foster, Donald F.	338
Burt	76, 239	Foundations, Concrete at Silver	
Butters	16, 237	Peak	264
Continuous	194	Freeing Sapphires from Matrix.	106
Hunt	46, 239	Fricker, R. G.	240
Leaves, Silver on	378	Frictional Loss in Ore Crushing	22
Merrill	239	Frue Vanner	76, 167, 203
Moore	369	Fuel Oil	45
Oliver Continuous	333	Furnace, Edwards	44
Ridgway	145, 235, 237, 238, 325, 369	Holthoff	104
Sand-Slat, Construction of... ..	217	Melting, Description of	322
Slat-Sand	50	Merton	44, 82
Tables, Rotary	305	Reverberatory	94
Vacuum Process	190	Gates Crusher	10
Filtering at Goldfield, Time of.	281	Rack and Pinion	12
Cost of	206	Gaze, W. H.	316
In Western Australia	376	Generation of Chlorine	155
Time Required, San Prospero		Geological Survey, United States	10
Mill	163	Geology of Cripple Creek	88
Filter-Press at El Oro	77	Gold and Silver Solutions, As-	
Dehne	82, 369, 376	say of	403
Johnson	19	Coarse and Fine, Cyaniding.. ..	63
Merrill	203	Or Silver-Bearing Solution,	
Perrin	158	Recovery of	365
Sweetland	357	Ore, Progress in the Treat-	
Filter-Pressing, Cost of	204	ment of	114
On the Rand	362	Solution, Errors of Estima-	
Filters, Comparison of	370	tion of	372
Submerged	146	Golden Cycle Mill	43 56
Vacuum	46	Goldfield, Chlorination at.	154, 155
Vacuum at Goldfield	279	Concentration at	56
Filtration by Pressure	356	Cost of Milling at	55
Vacuum	237	Metallurgical Development at	151
Fine and Coarse Gold, Cyanid-		Nevada	151
ing	63	Ore, Character of	153
Grinding Necessary	301	Ore, Description of.	39, 40, 41
First Cyanide Mill	250	Ores, Extraction on	52, 58
Leaching Solution	14	Ores, Tests on	41
Flotation at Broken Hill	243	Roasting Ore at	155
Methods	243	Tellurides at	40, 41
Processes	118, 235	Time Required Filtering	281
Flow-Sheet, Combination Mill.	152	Vacuum Filters at	279
Desert Mill	11		

	Page		Page
Goldfield Consolidated	156	Slime-Plant Costs	209
Mill	157	Honduras, Cyaniding at	253
Gould Pumps	259	Hornsilver	10
Grand Junction Mine	210	Hubbard, J. D.	318
Graphite	336, 372, 378	Hunt, Bertram	46, 48, 176, 216, 274, 316
Retorts, Life of	19	Hunt Filter	46, 219, 239
Graphitic Ores, Treatment of..	339	Huntington-Heberlein Process..	85
Grass Valley, California, Cya- niding at	231	Huntington Mills ...	13, 28, 75, 239
Cost of Treatment at.....	335	Hydrochloric Acid to Remove Lime Incrustation	255
Gravel Mill, Improvised	111	Hydrogen Sulphide in Ore Treat- ment	58
Great Boulder, Costs at	236	Improvements in the Cyanide Process	396
Mine	115	Improvised Gravel Mill	111
Grinding Action of Conical Tube-Mill	107	India, Kolar Mines	381
Mills, Operation of	28	Influence of Fine Iron on Zinc..	273
Pans	128	Interfering Base-Metal Salts... 	171, 174
Greenawalt, John E.	154	Investigation of Chemical Re- actions	183
Greenawalt and Argall	86	Iodide of Cyanogen	312
Grothe, Albert	60	Iron as a Cyanicide	231
Grothe-Mennell	375	Bar on Amalgam Plate	72
Guanajuato, Cost of Cyaniding at	170	Irvin, Donald F.	378
Cyanide Practice at	158	Ivanhoe Costs	236
Guanajuato Reduction & Mines Company	143	Jackling, D. C.	257
Guides, El Oro Type	159	Jackson Centrifugal Pumps ...	19
Hamilton, E. M.	37, 69, 73, 293, 372	James, Alfred	114, 233, 362
Handling of Tailing	13	Annual Cyanide Letter ..	362, 372
Hannan's Star Mine, Process at	226	James, W. H. Trewartha	176
Hanson, Henry	263	Janin, Louis, Jr.	286
Hardinge, H. W.	105, 139	Jaw Crushers	28
Hendryx Aeration System	402	Johnson Filter-Press	19
Hersam, Ernest A.	20, 106	Johnston Vanner	13
Hillebrand, W. F.	10	Kalgoorlie, Australia	84
History of Tube-Mill Linings.. 	120, 139	Slime Treatment at	82
Hobson, Francis J.	167	Kelly Press	247
Holbrook, E. A.	142	Kennedy, E. P.	67
Holden, Edwin C.	68	King, Lochiel M.	41
Holderman Process	262	Kinhead Mill	165
Holmes, W. L.	117	Kirby, A. G.	50
Holt, Theo. P.	186, 282, 403	Kniffin, Lloyd M.	382, 401
Holthoff Furnace	104	Kofa, Arizona, Losses at	247
Home-Made Cyanide Plant	231	Kolar, India	381
Homestake Mortar	201		

	Page		Page
Komata Reefs	117, 211	Process in Durango.....	169
Kominuter	43	Loss by Dusting and Volatiliza- tion	99
Korea, Cyaniding Concentrate in	318	By Friction in Ore Crushing..	22
Mining in	379	In Roasting Telluride Ores..	88
Recent Cyanide Practice in..	220	In Handling Zinc Shavings..	322
Treatment of Dumps in	379	Of Cyanide, Mechanical.....	247
Unsan	378	Louis, Henry	86
Krupp Tube-Mills	307	Lubricants, Character of.....	24
Laboratory Agitator, Brown ...	290	MacDonald, Bernard	164, 396
Experiment with Funnels ...	108	MacDonald, Joseph	145
La Luz, Mill Tests at	137	Mack, R. L.....	84
Lamb, Mark R.	37, 136, 145	Maclaurin, J. S.....	287
Lawlor, T. S.	290	Magenau, William	246
Leaching Agitator, Details of		Making Bromo-Cyanide	227
Construction	384	Manning, Utah, Mill at.....	262
Failure, Cause of	295	Martin, A. H.....	333
Sand at Grass Valey	232	Masonry Vats	160
Solution	14	Matting, Cocoa	308
Time of	14	McMiken, S. D.....	213
Lead Acetate	14	Mechanical agitators	16
Acetate, Function of	234	Excavator, Blaisdell	14
Acetate in Cyanidation	246	Handling of Tailing	13
Acetate <i>v.</i> Litharge	246	Loss of Cyanide	247
And Copper Ores, Effect of..	342	Mechanics of Ore Crushing....	35
Leaver, E. S.	198	Melting Bullion	250
Leslie, H. W.	381	Furnace, Description of.....	322
Liberty Bell Mill, Costs of Cya- niding at	148	Point of Calaverite	105
Mine	66	Mercur, Utah, Cyanidation at..	256
Life of Graphite Retorts.....	19	Milling at	48
Lime, Effect of Bromo-Cyanide		District, Character of Ore in.	256
Solution	231	Mill, Utah	260
Effect of, Solubility of Gold		Treatment at	257
and Silver	188	Mercury Seals, Use of.....	236
Excessive Use of	234	Merrill, C. W.....	46, 209
Removal from Zinc	224	Merrill Filter	239
Slacked	14	Plant at Deadwood	116
To Clarify Wash-Water	253	Presses	203
Versus Lime-Water	231	Merton Furnace	44, 82
Lining for Grinding Mills	141	Meserve, H. F.....	379
Of Tube-Mill	108, 120, 137, 206, 364	Metallurgical Development at	
Litharge, Effect of	189	Goldfield	151
Versus Lead Acetate	246	Patents	113
Lixiviation Plant, Durango, Mexico	168	Metals, Solution of	365
		Meter, Worthington	18
		Method of Saving Coarse Gold.	64
		Of Pulp-Agitation	401

Page	Page		
Of Treatment of Slime Con- centrate	190	Mortars, Multiple-Discharge . . .	374
Mexican Gold & Silver Company	176	Moulton, W. A.	148
Mexican Patent for Tube-Mill Lining	109	Multiple-Discharge Mortars . . .	374
Mexico, Cyanidation in	167	Muntz Metal	66
Mill at Manning, Utah.	262	Murphy Barrel	105
At Mercur, Utah.	260	Mysore, India	381
Combination at Goldfield.	51	Process at	381
Construction	306	Nardin, E. W.	226, 251
Desert	9	Narvaez, Francisco.	60, 239, 245
Dos Estrellas	118	Neal, Walter	248, 364, 389
Huntington	13	Necessity for Fine-Grinding. . .	301
Of Daly Reduction Company.	142	Neill, James W.	112
Of Goldfield Consolidated.	157	Nevada, Cyanidation in.	39
Of Montana Tonopah Com- pany	201	Nevada Gold Reduction Com- pany	154
San Francisco	60	New Zealand, Experience in.	210
Silver-Peak, Description of.	265	Noble, J. R.	213
Tests	136	Nicholas, Askin M.	112
Vulture, Arizona	50	Nichols, Horace G.	368
Yellow Jacket, Comstock Lode	165	Nichols, Ralph	376
Milliken, John Tait	43	Nicol, John M.	376
Milling and Cyaniding at San Prospero Mill	158	Noble, J. R.	213
At Dos Estrellas	394	North Star Mine, Grass Valley. 112, 333	
Cost at Combination Mill.	55	Notes, Cyanide	316
Cost at Silver Peak Mill.	272	On New Zealand Experience.	210
Practice, Nevada Goldfield Reduction Works	198	Nutter, Edward H.	66
Practice, Recent	378	Obstacle to Treatment, Graphite	336
Minas del Tajo, Mexico.	335	Oil as Fuel	45
Minerals Containing Tellurium.	85	Oliver, Edwin Letts	112, 333
Mining Costs in Africa.	235	Oliver Continuous Filter	333
In Korea	379	Ore Analysis	10
Modern Practice in Roasting Telluride Ores	102	Bin Gates	12
Montana Tonopah Company Mill	201	Character of	10
Moore, Chas. C. & Co.	9	Crushing	122
Moore, George	112	Crushing, Economy of Power in	26
Moore and Dehne Filters Com- pared	377	Crushing, Mechanics of	35
Filter	116	Goldfield, Description of.	39
Filter Patents	112	Of Tonopah, Character of.	201
Process	147, 304	Particles, Sizing of.	30
Morris Centrifugal Pump.	203	Physical Character of.	21
Mortar, Homestake	201	Power Required to Crush.	21
		Roasting	44, 49
		Sliming for Cyanidation.	37
		Telluride, Roasting of.	84

	Page		Page
Treatment, Associated North- ern Mine	82	Portland Gold Mining Company	312
Treatment, Combination Mill.	52	Portland Mine	88
Treatment, Mercur	48	Ore, Analysis of	89
Treatment, Scheme for	40	Potash, Caustic, Action of.....	288
Treatment, Western Australia	87	Potassium-Cyanide Vat	16
Orebodies, Tonopah	10	Power, Economy of Crushing	
Oriental Con. Mine, Korea.....	318	Ore	20
Overflow, Wier	300	Manning Mill	263
Overstrom Concentrator	144	Required to Crush Ore.....	21
Oxidizers	312	Victoria Falls	306
 		Practice on the Rand.....	330
Pachuca System	401	Rhodesia	114
Tank...60, 117, 157, 210, 365,	375	Precipitate, Assay of.....	326
Tank, Details of Construction	215	Briquetting	249
Tank, Disadvantage of.....	402	Flux for	250
Tank, Sizes of	214	Treatment at Dos Estrellas..	248
Packard, George A.....	69	Treatment of	19, 322
Palmer, Leroy A.....	256	Precipitating Boxes	19
Pan Amalgamation, Mexico....	168	Precipitation with Zinc Dust..	204
Pans, Grinding	128	Preliminary Roast	94
Panuco, Mexico	170	Pressure Filtration	356
Parral Tank	399	Process, Adair-Usher	243
Parrish, Edward	323	Arbuckle	367
Parsons, A. R.....	149	Boston-Sunshine Mill	303
Parsons, Cyril E.....	142	Cripple Creek	312
Patents, Moore Slime Filter... 112		Decantation	114
Tube-Mill Lining, and Slime		Ferreira	244
Filters	111	Flotation in Australia	235
Paul, Almarin B.....	63	Hannan's Star, W. A.....	226
Pebble-Mill	105	Holderman	262
Pebbles, Consumption of	206	Huntington-Heberlein	85
Percentage of Cyanide Extrac- tion	20	Tonopah Mill	203
Peripheral Discharge	242	Moore	147
Perrin Filter-Presses	158	Rand	305
Per-Sulphate of Ammonium... 313		Slime	233
Petroleum Fuel	45	Producer Gas	155
Philippines, Benguet	380	Progress in Cyanidation.....	233
Physical Character of Ore.....	21	In Treatment of Gold Ore... 114	
Pinguico, Costs of Cyaniding at	150	Protection from Cyanide Solu- tion	321
Pittsburg Silver Peak, Mines		Pryce Feeders	308
and Plants of the.....	263	Pulp-Agitation, Methods of... 401	
Plan, Silver Peak Mill.....	268	Pump, Aldrich Triplex.....	204
Plant, Benguet, P. I.....	380	Dixon	233
Pittsburg Silver Peak.....	263	Morris Centrifugal	203
Plates, Amalgamating, Remov- al of	234	Versus Gravity Filling, Rela- tive Cost of	82
		Pumps, Butters Centrifugal... 12	

	Page		Page
Gould Rotary	259	Ribbed Plate at El Oro.....	138
Wheeler Centrifugal	9	Rickard, T. A.....	151
Putnam, Dana G.....	247	Ridgway Filter.....	115, 145, 235, 237, 238, 325, 369
Pyrite, Action of Bromo-Cya- nide on	230	Riley, R	121
Pyrometer, Fery	93	Risdon-Johnston Concentrators	144, 166
Pyrrhotite	372	Roast, Preliminary	94
Question	63	Roasting	239
Rand Centrifugal Pump.....	332	Experimental	93
Filter Pressing on the.....	362	Ore	44, 49, 84
Practice	330	Ore at the Eagle Shawmut...	45
Process on the	305	Ore at Goldfield.....	41, 155
Simmer Deep and Jupiter Re- duction Works	305	Telluride Ores	84
Stamp Capacity	235	Telluride Ores, Aim of.....	91
Rapid City, Lane Mill.....	68	Telluride Ores, Cost of.....	92
Rate of Solubility of Silver in Ore	282	Robins Belt Conveyor	10, 159
Ratio of Silver to Gold.....	10	Robinson Deep, Tube-Mills at.	240
Reactions in Cyaniding....	171, 183	Rock Crusher, Gates	10
Read, Thomas T.....	84	Crushing, Theory of. 28, 31, 32, 33	
Recent Cyanide Mill in Mexico.	143	Roller Mills	28, 132
Cyanide Practice in Korea...	220	Rolls, Crushing Action of....	124
Reciprocating Crushers	125	Rosario Mine, Honduras, Costs	
Recovery of Gold or Silver- Bearing Solution	365	at	253
Regeneration of Cyanide Solu- tion	384	Mine, Process at.....	253
Of Cyanide Solution, Acid		Rose, T. K.	245
Test on	341, 352	Rotary Filter-Tables	305
Re-grinding in Huntington Mills	13	Rotherham, G. H.....	201
Reid, Walter L.....	67	Sampler, Automatic	304
Reinforced Concrete Mortar		Snyder	11
Foundations	264	San Francisco Mill, Process at	60
Relative Cost Gravity <i>v.</i> Pump		San Prospero Mill, Cyaniding	
Filling	82	and Milling at	158
Removal of Amalgamating		San Rafael Mine Ore Extrac- tion	62
Plates	234	Sand and Slime Separator....	295
Removing of Lime from Zinc		Collector	296, 299
Shavings	224	Continuous Collection for	
Results of Tube-Milling.....	240	Cyaniding	329
Retorts, Life of Graphite....	19	Leaching at Grass Valley...	232
Reverberatory Furnaces	94	Plant	159
Rhodes, C. E.....	109, 150	Sizing Test of Residue....	14
Rhodesian Practice	114, 363	Treatment	13
Rib-Liner	110	Sapphires, Freeing from Ma- trix	106
		Saving Gold, Silver, and Cop- per with Sulphuric Acid..	352

	Page		Page
Scheme of Ore Treatment....	40	Smuggler-Union Mine	65
Schorr, Robert	194	Snyder Sampler	11, 12
Scibird, G. H.	84	Sodium Bisulphide, Use of....	311
Screen Tests	30, 57, 89	Cyanide	142
Screens, Crimped Wire	159	Cyanide, San Prospero Mill.	163
Second Treatment	14	Solubility Curves	161
Separator for Slime and Sand	295	Rate of Silver in Ore.....	282
Settlement Process	368	Solution Assay at El Oro.....	80
Sharwood, W. J.	178	Assay of Gold-Silver Cyanide	403
Silver, Character of	10	Crushing in	63
Chloride	10	Metals	365
In Ore, Rate of Solubility of	282	Precipitated Amount of	19
On Filter Leaves	378	Recovery of Gold on Silver	
Ores, Cyanidation of.178, 282,	382	Bearing	365
Ores, Variations in Treat-		Solvent for Silver	313
ment of	284	Special Vat for Cyanide Solu-	
Solvent	313	tion	16
Silver Peak, Mines and Plants		Spitzkasten	13
of the Pittsburg	263	Diaphragm	364
Simmer Deep and Jupiter Re-		Stamp Battery	28
duction Works	305	Boss	130
Sinaloa, Mexico	167	Capacity of the Rand	235
Size of Crushing	10	Drop of	12
Of Pachuca Tanks	214	Duty	12
Sizing of Ore Particles	30	Duty at Dos Estrellas	119
Tests	12, 14, 57, 89	Guides, El Oro	158
Slime and Sand Separator....	295	Stems, Vibration of	131
Analysis of Sulphide	388	Wear of	126
Definition of	293, 323	Static-Electric Process, Blake..	106
Filter, Continuous	194	Steam, Condensation of	9
Plant Costs, Homestake	209	Stamps	28
Plant, Decantation	310	Stolen Ore, Treatment of.....	155
Plant Equipment	16	Strengthening Solution	16
Processes	233	Submerged Filters	146
Thickener	159, 303	Subsidiary Filter	46
Treatment	243	Sulman, H. L.	251
Treatment at Kalgoorlie....	82	Sulman Feed Process	250
Treatment of a Concentrate.	190	Sulphide Ores, Goldfield	50
Treatment, Theory of	324	Slime, Analysis of	388
Sliming Ore for Cyanidation.	37	Sulpho-Tellurides	226
Shoes and Dies, Chrome Steel	12	Sunshine Mill, Boston	303
Short Zinc	273	Sweetland, Ernest J.	356
Skill in Rock Breaking	26	Sweetland Filter-Press	357
Slacked Lime	14	Swan, Henry L.	365
Slat-Sand Filter	46, 217	Table, Cement Covered	159
Slosson, H. L.	165	Deister	157
Smith, Alfred Merritt	279, 369		
Smith, F. C.	88		

	Page
Tailing, Mechanical Handling	
of	13
Wheel	12
Talcose Ore	303
Tank, Parral	399
Taracol, Korea	246
Tays, E. A. H.	67, 169
Telluride at Goldfield ...	40, 41, 50
Ores, Action Under High	
Temperature	92
Ores, Assay of	90
Ores, Cripple Creek	312
Ores, Discovery of	84
Ores, Modern Practice in	
Roasting	102
Ores, Roasting of	84
Tellurium Gold Ore, Experi-	
ment With	48
Minerals	85
Temperature Curves	100, 101
Determinations	93
Of Ore Roasting	49
Test by Screening	89
Of Consistence of Tube-Mill	
Feed	391
On Acid Regeneration of Cy-	
anide Solutions	341, 352
On Goldfield Ores	41
On Zambona Ores	383
Sizing	12, 14
Testing Bromo-Cyanide	228
Thomson, J. A.	213
Time of Filtering, Goldfield..	281
Of Filtering, San Prospero	
Mill	163
Of Leaching	14
Operating Butters Filter ...	18
Tripper, Automatic	14
Tonopah Mining Co. of Nevada	9
Orebodies	10
Treatment at Mysore	381
At Silver Peak Mill	266
Comparisons in	236
Cost at North Star Mine....	335
Of Argentite	176
Of Coarse Gold	60, 70, 72
Of Concentrate Slime	190
Of Gold Ore, Progress in....	114

	Page
Of Ore at Associated North-	
ern Mine	82
Of Ore at Combination Mill,	
Goldfield	52
Of Ore at Mercur	48, 257
Of Precipitate	248, 322
Of Sand	13
Of Silver Ore, Variation in..	284
Of Slime at Kalgoorlie	82
Of Stolen Ore	155
Of Telluride Ores	86
Of Zinc Precipitate	19
Scheme for Ore	40
Trent Agitation System	402
Triplex Pump, Aldrich	204
Tripper, Automatic	14
Tube Mill	29, 136, 363
Mill, A Conical	105
Mill at El Oro	240
Mill at Robinson Deep	240
Mill at Tonopah	202
Mill, Improvised	111
Mill, Krupp	307
Mill Lining.....	108, 120, 137,
141, 206, 364	
Mill Lining, Mexican Patent	
for	109
Mill Lining, Slime Filters,	
and Patents	111
Mill Results	240
Milling and Diaphragm Cones	389
Milling, Best Percentage of	
Dilution of Pulp for	395
Milling, Cost of	205
Union Iron Works	12
United States Geological Sur-	
vey	10
Unsan, Korea	378
Use of Lime in Excess	234
Of Mercury Seals	236
Vacuum and Dehne Filters	
Compared	372
Filter	46, 115
Filter and Agitator Com-	
bined	225
Filter, Continuous	216

	Page		Page
Filter Process	190	West, H. E.	137
Filtration	38, 237	Western Australia, Filtering in	376
Slime-Filters at Goldfield...	279	Australia Treatment	338
Van Law, C. W.	65	Wet and Dry Methods, Compar-	
Vanner, Frue	167, 203	ison of	47
Johnston	13	Wheeler Centrifugal Pumps ...	9
Variations in Treatment of Sil-		Pans	82
ver Ores	284	Wheelock, R. P.	341, 352
Various Filters Compared	370	Whitman, P. R.	299
Vat, Collector	309	Wilfley Concentrators	12, 13,
Masonry	160		86, 154, 160
V-Boxes	13	Williams, J. R.	362
Viator	45, 63	Willis, H. T.	274
Vibrating Concentrator	13	Wire Screens, Crimped	159
Vibration of Stamp-Stems....	131	Wood, G. W.	303
Victoria Falls Power	306	Works of Simmer Deep and Ju-	
Virginia City, Butters Plant at		piter	305
	50, 165	Worrell, S. H.	250
Virgoe, Walter H.	176	Worthington Meter	18
Volatilization and Dusting Loss	99	Wyly, A. J.	377
Von Bernewitz, M. W.	316, 336,		
	339, 377	Yellow Jacket Mill, Comstock	
Vulture Mill, Arizona	50	Lode	165
Waihi Grand Junction Co., Ltd.	138	Zambona Mine, Mexico	382
Walker, E. N.	197	Zinc, Action of Fine Particles	
Ward, O. B.	226	of Iron Upon	274
Wash Water	14	Boxes	19
Water, Disposition of En-		Boxes, Loss in	322
riched	280	Dust at Silver Peak Mill....	270
Washing and Cyanicides	380	Dust Consumption of	205
Water, Wash	14	Dust Precipitation	204
Wear of Stamps	126	Precipitate, Treatment of....	19
Weir Overflow	300	Shavings, Removal of Lime	
Wells, J. S. C.	69, 72	from	224

Mining and Scientific Press

Established 1869.

CONTROLLED BY T. A. RICKARD.

EDITOR - - H. FOSTER BAIN

Subscription Price:

United States and Mexico - - - - -	\$3
Canada - - - - -	4
Other Countries - - - - -	5

The latest accurate mining news every Saturday. Published at a great mining centre, by engineers for engineers.

The established organ of the profession. Valuable and timely discussions of the daily problems of the men at the mine, mill, and smelter.

667 Howard St.,

San Francisco, California.

London Office, 819, Salisbury House, E.C.

COMBINATION SUBSCRIPTION PRICE.

To new subscribers to both papers in

United States, Mexico, and Canada - - - - -	\$6 (24s.)
United Kingdom - - - - -	7 (28s.)
Other Countries in Postal Union - - - - -	8 (32s.)

The Mining Magazine

Established September 1909.

T. A. RICKARD, Editor.

EDGAR RICKARD, Business Manager.

Subscription Price:

United Kingdom and Canada - - - - -	12s. (\$3)
Other Countries - - - - -	16s. (\$4)

A monthly magazine is the natural corollary of a technical weekly. It permits of more deliberate and more extended notice of matters concerning which the news element is less important.

THE MINING MAGAZINE includes a review of the world's progress in mining, metallurgy, and economic geology, written by men who have personal knowledge of the regions and conditions discussed.

819, Salisbury House, London, E. C., England.

San Francisco Office, 667 Howard St.

THE OLIVER FILTER

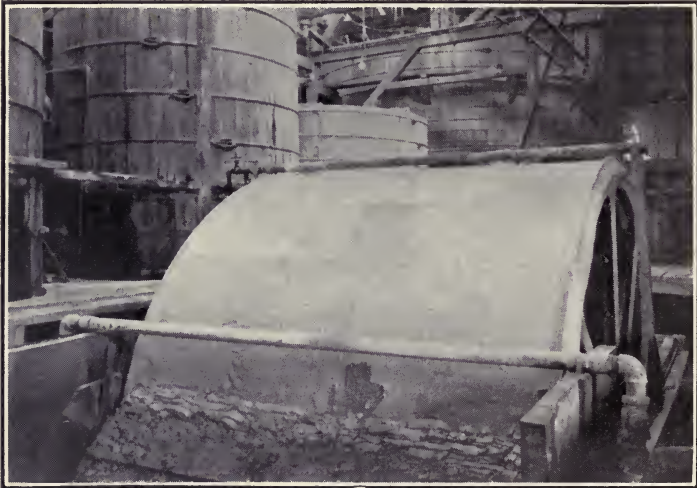

One of Four Oliver Continuous Filters at North Star Mines, Grass Valley, Cal.

CONTINUOUS AUTOMATIC EFFICIENT LABOR SAVING

☐ Not an experiment. In practical operation since 1908. Over 35 installations in September, 1910, in United States, Mexico, Central America, Canada, and Philippine Islands.

FULL INFORMATION ON REQUEST.

PATENTED APRIL 27, 1909.

THE OLIVER CONTINUOUS FILTER CO.
7 AND 9 FIRST ST.
SAN FRANCISCO, CAL.

THE MOORE SLIMES PROCESS

"The first epoch-making improvement in Cyanidation."

WHAT EVERY METALLURGIST THE WORLD OVER NOW KNOWS:

(And therefore must have their opinion of those who publish statements to the contrary). That the only plants in existence in 1903 equipped with "Vacuum Filters" were

"MOORE SLIMES PROCESS PLANTS"

at the Buxton & Big Bonanza and Consolidated Mercur Gold Mines Co., Mercur, Utah, and Lundberg, Dorr & Wilson, Terry, South Dakota.

AND FURTHER: That every Vacuum Slimes Filtration Plant since then installed (no matter by what name called) is a

"MOORE SLIMES PROCESS PLANT."

THAT: Anyone using this Process under alleged rights obtained from others, UNDER WHATSOEVER NAME OR "GUARANTEE," SO-CALLED, will very soon have to account to THE MOORE FILTER COMPANY in HEAVY DAMAGES for every ton of ore treated.

Full Particulars, Detail Drawings, Specifications, and all necessary Engineering Data acquired by an Engineering Staff, EXPERIENCED not only in DESIGNING, but in the OPERATION of the Plants, may be obtained by applying to either of the following representatives:

LONDON:

BERTRAND C. HINMAN,
Coventry House, South Place, E.C.
Cable: Underfeed, London.

WEST AUSTRALIA:

FRANK R. PERROT,
883 Hay Street, Perth.
Cable: Lapwing, Perth.

MEXICO:

THE MOORE FILTER CO.,
32 Ave Cinco de Mayo,
Mexico, D.F.
Cable: Morefilter, Mexico.

AUSTRALIA (except W. A.):

A. J. M. CHAPPLE,
Oriental Street, Stawell, Victoria.
Cable: Chapple, Stawell.

SOUTH AFRICA:

HERBERT AINSWORTH,
Johannesburg.
Cable: Ainsco, Johannesburg.

PERU:

NICANOR GARCIA Y LASTRES,
Pasaje No. 2 Lima.

THE MOORE FILTER COMPANY

This Company either EXCLUSIVELY OWNS or EXCLUSIVELY CONTROLS the Moore-Cassel-Clancy Patents and pending applications.

Cable: **New York, U. S. A.**
Morefilter, New York.

Code:
Bedford McNeill.

Books published and for sale by the **MINING AND SCIENTIFIC PRESS**. Home office: 667 Howard St., San Francisco. Branch offices: Chicago, 934 Monadnock Block; New York, 29 Broadway; Denver, 420 McPhee Bdg.; London, **THE MINING MAGAZINE**, 819 Salisbury House, E. C.

THROUGH THE YUKON AND ALASKA.

By **T. A. RICKARD.**

This book is *not* a re-print of articles already published, but a non-technical description of a region of great technical interest. The scenery, people, and industries of the North are described by a traveler trained to observe and to write in an interesting manner.

400 Pages; 175 Illustrations; Indexed. \$2.50 postpaid.

AARON'S ASSAYING.

By **C. H. AARON.**

Standard Texts Based on Experience.

PART I.—Gold and Silver Ores.

Sixth Edition. 140 Pages; Indexed. \$1 postpaid.

PARTS II and III—Gold and Silver Bullion, Lead, Copper, Tin, Mercury.

Fourth Edition. 162 Pages; Indexed. \$1.50 postpaid.

METALLURGY OF THE COMMON METALS.

By **LEONARD S. AUSTIN.**

Principles and methods are so discussed and illustrated as to give a solid foundation for special studies.

Second Edition. 500 Pages; Illustrated; Indexed. \$4 postpaid.

DREDGING FOR GOLD IN CALIFORNIA.

By **D'ARCY WEATHERBE.**

The only book giving details of costs and methods of dredging written from first-hand information. Illustrated with diagrams, drawings, and photographs.

220 Pages; Indexed. \$4 postpaid.

FIRE ASSAY.

By **LEONARD S. AUSTIN.**

There are many books on assaying. This is the one to keep on your bench for reference.

88 Pages; Illustrated; Indexed. \$1 postpaid.

HINTS ON AMALGAMATION AND THE CARE OF GOLD MILLS.

By **W. J. ADAMS.**

A reference book of Actual Gold Mill Practice as determined by an experience of 20 years.

Second Edition. 120 Pages; Illustrated; Indexed. \$2 postpaid.

JOURNEYS OF OBSERVATION.

By **T. A. RICKARD.**

Mexico and the San Juan District of Colorado as seen by a mining engineer.

400 Pages; Beautifully Illustrated; Indexed. \$3.50 postpaid.

RECENT CYANIDE PRACTICE.

Edited by T. A. RICKARD.

The best things by those best qualified to write on this important branch of metallurgy.

350 Pages; Illustrated; Indexed. \$2 postpaid.

MORE RECENT CYANIDE PRACTICE.

Edited by H. FOSTER BAIN.

In 'More Recent Cyanide Practice' are compiled the leading articles on cyanidation that have appeared since 'Recent Cyanide Practice' was published.

The result is an invaluable compendium of data relating to mill construction and operation, to costs, and to the chemistry of the process, written by the men who have built and operated the latest and best mills, and the chemists and metallurgists who have solved the problems as they arose.

420 Pages; Illustrated, Indexed. \$2 postpaid.

TESTING FOR METALLURGICAL PROCESSES.

By J. A. BARR.

This unique little book is designed to assist in the selection of the process of treatment for any ore. The author describes the apparatus and methods employed in making laboratory and small-lot tests. It is founded upon experimental work at the Michigan College of Mines, and the methods recommended have been tested in practice. It is brief and practical, equally valuable to the student and practicing engineer.

160 Pages; Illustrated; Indexed. \$2 postpaid.

PRACTICAL STAMP MILLING AND AMALGAMATION.

By H. W. MacFARREN.

The product of experience enriched by observation. Gives details needed in every-day work. The stamp-mill, its location and design; the mortar, die, shoes, tappet, and cam; adjustment of height, order of drop, feeder, and screens; water supply and power; principles of amalgamation and treatment of plates; retorting; loss of gold, mill tests, and mill management; all these are treated in an illuminating manner by one who has himself solved the problems.

180 Pages; Indexed. \$2 postpaid.

A GUIDE TO TECHNICAL WRITING.

By T. A. RICKARD.

The man who knows how is always in demand, but he must know how to tell what he knows or he remains undiscovered.

Second Edition, Revised. 170 Pages; Indexed. \$1 postpaid.

VAN NORDEN'S COMPUTER.

This enables the hydraulic engineer to use slide-rule methods in his every-day calculations.

\$3.50 postpaid.

AFTER EARTHQUAKE AND FIRE.

A permanent record of the history-marking experience of San Francisco in April 1906. The book is of great technical interest to geologists and engineers, and an excellent aid to teachers.

194 Pages; Handsomely Illustrated. \$1 postpaid.

Technical Books

A LARGE STOCK of technical books always on hand enables us to make prompt shipments. We will be glad to advise the best books on any particular subject.

SEND FOR A CATALOGUE

Mining and Scientific Press

667 Howard St., San Francisco

THE MINING MAGAZINE, 819, Salisbury House
London, E. C.



YC 33911

YC 33911

M127120 TN 767

B3

1910

cop. 3

Mining
dept

THE UNIVERSITY OF CALIFORNIA LIBRARY

