



Mosquito Control in Panama

The Eradication of Malaria and Yellow Fever in
Cuba and Panama

BY

Joseph A. Le Prince, C.E., A.M.

Chief Sanitary Inspector, Isthmian Canal Commission
1904-1914

and

A. J. Orenstein, M.D.

Assistant Chief Sanitary Inspector, Isthmian Canal Commission

With an Introduction by

L. O. Howard, LL.D.

Entomologist and Chief, Bureau of Entomology
United States Department of Agriculture

With 100 Illustrations



G. P. PUTNAM'S SONS
NEW YORK AND LONDON
The Knickerbocker Press

1916

RC116
L43

COPYRIGHT, 1916
BY
JOSEPH A. LE PRINCE



\$2.50

The Knickerbocker Press, New York

FEB 17 1916

© Cl. A 418849

no. 1.

INTRODUCTION

^{theo}
PRESIDENT ROOSEVELT early appreciated the fact that great as were the engineering difficulties to be surmounted in the making of the Panama Canal, the difficulties of sanitation would be fully as great, if not greater, and, before the first Canal Commission was appointed, he told a committee of the American Medical Association, the American Association for the Advancement of Science, and the New York Academy of Medicine, consisting of Doctor Welch and Doctor Osler of Baltimore, Doctor Musser of Philadelphia, Doctor Bryant of New York, and the writer, that it was his intention to seek for the best man in the world for the task, to pay him whatever would be necessary, and to give him full power. Fortunately, the man needed was found in the person of Colonel (now General) Gorgas, fresh from his triumphant cleaning up of Havana with the consequent elimination of yellow fever and malaria. General Gorgas took with him from Cuba to Panama a man who

had been his right hand in the cleaning up of Havana, J. A. Le Prince, the author of this book.

The writer well remembers one morning when, before starting for Panama, General Gorgas and Mr. Le Prince called on him at his office in Washington to talk about mosquitoes, and the confidence which they felt of accomplishing their gigantic task was inspiring. He asked General Gorgas to have specimens of all the Panama mosquitoes sent to him for naming, and the General said, "I will assign Mr. Le Prince to see that it is done." Upon which Mr. Le Prince remarked, "I will have to do it soon, Doctor, for in a year or so there will be no mosquitoes there!"

The brilliant results of the work of General Gorgas and his assistants are now known over the whole civilized globe. It has been an object-lesson for the sanitarians of the world and has demonstrated the vitally important fact that it is possible for the white race to live healthfully in the tropics.

And now, the whole world wants to know how they did it. Every detail becomes of the greatest interest, and, in consequence, what Mr. Le Prince has written here will be not only of great practical importance as a guide to

Introduction

v

future work of the same character, especially in the tropics, but also of permanent historic value.

L. O. HOWARD.

BUREAU OF ENTOMOLOGY,

U. S. DEPARTMENT OF AGRICULTURE.



CONTENTS

PART I. ANTI-MALARIA CAMPAIGN

| CHAPTER | PAGE |
|---|------|
| I.—THE STATUS OF KNOWLEDGE OF ANTI-MALARIA WORK IN 1904 AND THE PREVIOUS CAMPAIGN IN HAVANA . | 3 |
| II.—THE SITUATION ON THE ISTHMUS IN 1904, BEFORE AMERICAN OCCUPATION . | 16 |
| III.—METEOROLOGICAL AND TOPOGRAPHICAL CONDITIONS. TOPOGRAPHICAL CHANGES AND THEIR BEARING ON ISTHMIAN ANOPHELES | 27 |
| IV.—THE SPECIES OF ANOPHELES ON THE ISTHMUS | 43 |
| V.—ANOPHELES PROPAGATION AREAS | 55 |
| VI.—HARBORING PLACES AND FOOD OF ANOPHELES | 83 |
| VII.—FLIGHT AND ATTRACTION OF MOSQUITOES | 94 |

| CHAPTER | PAGE |
|--|------|
| VIII.—ATTACK ON PROPAGATION AREAS BY FILLING | 115 |
| IX.—ATTACK ON PROPAGATION AREAS BY DRAINAGE | 122 |
| X.—ATTACK ON PROPAGATION AREAS BY OILING | 151 |
| XI.—ATTACK ON PROPAGATION AREAS BY LARVICIDES | 173 |
| XII.—ATTACK ON PROPAGATION AREAS AND ADULT MOSQUITOES BY NATURAL ENEMIES | 180 |
| XIII.—ATTACK ON PROPAGATION AREAS BY CLEARING BODIES OF WATER | 190 |
| XIV.—ATTACK ON PROPAGATION AREAS BY REMOVAL OF JUNGLE | 195 |
| XV.—SCREENING AND PRACTICAL DESTRUC- TION OF ADULT ANOPHELES IN HOUSES | 198 |
| XVI.—THE RESULTS ACCOMPLISHED BY THE ANTI-MALARIA CAMPAIGN | 218 |

PART II. THE YELLOW FEVER CAMPAIGN

| | |
|--|-----|
| I.—THE CAMPAIGN IN HAVANA | 231 |
| II.—THE SITUATION ON THE ISTHMUS BEFORE SANITARY WORK WAS STARTED | 261 |

Contents

ix

| CHAPTER | PAGE |
|--|------|
| III.—GEOGRAPHY, METEOROLOGY, ETC., AND THEIR BEARING ON THE PRESENCE OF <i>AËDES CALOPUS</i> | 268 |
| IV.—THE FIRST SANITARY WORK DONE IN PANAMA—ITS PURPOSE | 271 |
| V.—THE ANTI-YELLOW FEVER CAMPAIGN AND ITS RESULTS | 293 |
| VI.—MEASURES TAKEN TO KEEP THE ISTH- MUS FREE FROM YELLOW FEVER . | 306 |
| VII.—THE VALUE OF YELLOW FEVER ERADI- CATION IN THE CONSTRUCTION OF THE PANAMA CANAL | 314 |
| INDEX | 325 |

NOTE—The word mosquito refers to the *Anopheles* in Part I., and to *Aëdes calopus* in Part II., unless otherwise stated.



ILLUSTRATIONS

| | PAGE |
|---|------|
| CHART SHOWING MALARIA DEATH-RATE AT HAVANA, 1871 TO 1914 | 13 ✓ |
| ANT-GUARDS: OLD HOSPITAL AT ANCON | 18 ✓ |
| A DITCH AT ANCON: WEEDS RETARDING WATER FLOW | 20 ✓ |
| JUNGLE COVERING A STREAM | 22 ✓ |
| MAP OF THE CANAL ZONE | 26 ✓ |
| METEOROLOGICAL TABLES I TO 9 | 28 ✓ |
| RAINFALL: CURVES FOR 1909, 1912, 1913 | 37 ✓ |
| A TOPOGRAPHIC CHANGE: NEAR EMPIRE | 38 ✓ |
| CONSTANTLY CHANGING TOPOGRAPHY: NEAR MIRAFLORES | 38 ✓ |
| DAILY CHANGE OF TOPOGRAPHY | 40 ✓ |
| BLOCKED WATER-COURSE CHANGED INTO AN <i>ANOPHELES</i> BREEDING PLACE | 42 ✓ |
| AQUATIC VEGETATION SHELTERING LARVÆ | 48 ✓ |
| SWAMP NEAR BALBOA, CAUSED BY BUILDING OF DIKES | 52 ✓ |

| | PAGE |
|--|------|
| THE RISING WATERS OF GATUN LAKE | 54 ✓ |
| CATTLE ON LOW PASTURE LANDS: PANAMA | 56 ✓ |
| THE EFFECT OF FLOODS: EMPIRE | 58 ✓ |
| ALGÆ UNITED WITH OIL IN MAT-LIKE MASSES: EMPIRE | 58 ✓ |
| RAILROAD TIE LEFT IN A TREE BY A SUBSIDING FLOOD | 62 ✓ |
| OILING OF BREEDING PLACES ALONG A RIVER- BANK | 64 ✓ |
| VEGETATION PROTECTING MOSQUITO LARVÆ | 66 ✓ |
| A SEEPAGE OUTCROP, CONTROLLED BY AN INTER- CEPTING TILE DITCH: ANCON | 68 ✓ |
| VEGETATION REMOVED FROM THE EDGE OF A POND AT BOHIO | 70 ✓ |
| RESULT OF BLOCKING THE RIO CARDENAS | 72 ✓ |
| PROPAGATION AREA OF GATUN MOSQUITO INFLUX WHERE MOSQUITO FLIGHT WAS DISCOVERED | 76 ✓ |
| DETAIL OF <i>ANOPHELES</i> BREEDING GROUND WHERE FLIGHT OBSERVATIONS WERE MADE | 78 ✓ |
| GRASS AND PLANTS ALMOST COVERING THE WATER SURFACE AND PROTECTING MOSQUITO LARVÆ | 78 ✓ |
| DIAGRAMS SHOWING BEST LOCATIONS FOR SCREENED DOORS | 87 ✓ |

Illustrations

xiii

| | PAGE |
|--|-------|
| <i>ANOPHELES</i> COLLECTED IN THE GROUND CRACKS UNDER THE HOUSES | 90 ✓ |
| THE RELATIVE POSITIONS OF PANAMA, ANCON, COROZAL, AND MIRAFLORES | 95 ✓ |
| MOSQUITO TRAP ATTACHED TO A WINDOW SCREEN | 96 ✓ |
| MOSQUITO TRAP (SEEN FROM INSIDE THE HOUSE) | 96 ✓ |
| EXPERIMENT STATION: COROZAL | 98 ✓ |
| THE SHORE OF GATUN LAKE | 100 ✓ |
| MAP OF GATUN: SHOWING <i>ANOPHELES</i> PROPAGATION AREA AND HOUSES WHERE STAINED SPECIMENS WERE RECAPTURED | 101 ✓ |
| FLOATING ISLANDS BLOWN TOWARD GATUN LAKE | 102 ✓ |
| MASSES OF AQUATIC PLANTS AND FLOATING ISLANDS IN GATUN LAKE | 102 ✓ |
| THE <i>ANOPHELES</i> BREEDING GROUND NEAR GATUN | 106 ✓ |
| A DEVICE FOR DETERMINING THE FLIGHT DIRECTION OF <i>ANOPHELES</i> | 108 ✓ |
| TABLE SHOWING NUMBER OF <i>ANOPHELES</i> CAUGHT IN HOUSES AT GATUN | 110 ✓ |
| STAINING <i>ANOPHELES</i> WITH ANILINE DYE TO DETERMINE LENGTH OF FLIGHT | 112 ✓ |

| | PAGE |
|--|-------|
| <i>ANOPHELES</i> IN A MOSQUITO-BAR EXPOSED TO AIR CURRENTS AT NIGHT | 114 ✓ |
| CRACKS IN A HYDRAULIC FILL | 120 ✓ |
| LONGITUDINAL SECTION AND CROSS-SECTION OF AN INTERCEPTING TILE DRAIN | 131 ✓ |
| DETAIL OF OUTLET OF A TILE DRAIN | 135 ✓ |
| PLAN AND SIDE VIEW OF A JUNCTION OF TILE LINES | 136 ✓ |
| CONCRETE LINING OF A DITCH OF SMALL CROSS- SECTION | 138 ✓ |
| REINFORCED THIN CONCRETE LINING OF A ROADSIDE DITCH, AND SUPPORT OF THE SLIDING TOE OF A HILL WITH CONDEMNED CROSS-TIES | 138 ✓ |
| PLAN AND CROSS-SECTION OF A KEY-WALL AND POSITION OF WEEP-HOLES | 139 ✓ |
| CONCRETE DITCH LINING | 140 ✓ |
| CONCRETE LINED DITCH AT BALBOA | 140 ✓ |
| KEY-WALLS TO PREVENT WATER LEAVING LINED DITCHES | 140 ✓ |
| BRANCH DITCHES | 141 ✓ |
| JUNCTION OF CONCRETE DITCHES, SHOWING SPLASH-WALL | 142 ✓ |
| CONCRETE LINING FOR THE BOTTOM OF A SMALL DITCH | 142 ✓ |

Illustrations

xv

| | PAGE |
|---|-------|
| JUNCTION OF A BRANCH DITCH WITH A LINED DITCH | 143 ✓ |
| BURNING GRASS FROM THE SIDE OF A DITCH; CRUDE OIL USED AS FUEL | 144 ✓ |
| CONDITION OF THE DITCH TWO MONTHS AFTER BURNING. | 146 ✓ |
| DITCH CLEARED BY HAND LABOR, SHOWING CONDITION TWO MONTHS AFTER REMOVING GRASS | 148 ✓ |
| A GATE TO IMPOUND WATER FOR FLUSHING A DITCH: EMPIRE | 150 ✓ |
| REMOVAL AND DESTRUCTION OF LARVÆ AND MATTED ALGÆ IN A DITCH BY FLUSHING: EMPIRE | 150 ✓ |
| A SIMPLE FORM OF OIL DRIP | 158 ✓ |
| THE FLAT LAMPWICK DRIP FOR HEAVY OILS | 160 ✓ |
| OIL DRIP APPLIED TO A HILLSIDE STREAM | 162 ✓ |
| OILING OBSTRUCTED STREAMS ON CUT-OVER LANDS | 164 ✓ |
| BRUSH IN VALLEY OF PEDRO MIGUEL RIVER | 164 ✓ |
| APPLICATION OF LARVACIDE OR OIL BY KNAP- SACK SPRAYER: MIRAFLORES | 166 ✓ |
| SPRAY NOZZLES | 167 ✓ |
| FIELD SUPPLY TANK | 168 ✓ |
| OIL-CART FOR APPLYING OIL TO ROADSIDE DITCHES | 168 ✓ |

| | PAGE |
|---|-------|
| PACK-MULES, FOR OIL TRANSPORTATION IN JUNGLE TRAILS | 170 ✓ |
| THE LARVACIDE PLANT AT ANCON | 174 ✓ |
| REMOVING VEGETATION FROM OVERGROWN STREAMS | 192 ✓ |
| SCREENED VERANDAS: ANCON | 192 ✓ |
| A GOOD DEVICE TO PREVENT THE SAGGING OF SCREENED DOORS | 201 ✓ |
| TYPES OF SCREENED HOUSES: COLON HOSPITAL GROUNDS | 204 ✓ |
| TYPES OF SCREENED HOUSES: CULEBRA | 206 ✓ |
| SCREENED CARS IN RAILROAD CONSTRUCTION CAMPS | 206 ✓ |
| TABLE OF MALARIA INCIDENCE AT CONSTRUC- TION CAMPS | 209 ✓ |
| SLAPPER, CHLOROFORM TUBE, ACETYLENE LAMP, AND PILL-BOX; USED IN CATCHING <i>ANOPHELES</i> IN HOUSES | 212 ✓ |
| MOSQUITO TRAP, WITH DETAILS OF CON- STRUCTION | 214 ✓ |
| INTERIOR OF LABORERS' BARRACKS; WHERE <i>ANOPHELES</i> WERE CAUGHT DAILY | 216 ✓ |
| CHART SHOWING PERCENTAGE OF EMPLOYEES SICK WITH MALARIA IN THE WET SEASONS OF 1911, 1912, AND 1913 | 221 ✓ |

Illustrations

xvii

| | PAGE |
|--|-------|
| DIAGRAM SHOWING THE YEARLY REDUCTION OF MALARIA AMONG CANAL EMPLOYEES | 226 ✓ |
| CHART SHOWING THE MONTHLY MALARIA SICK-RATE FROM 1906 TO 1914 | 228 ✓ |
| MAP OF HAVANA; SHOWING THE YELLOW FEVER DISTRICT | 236 ✓ |
| CHART SHOWING THE PREVALENCE OF YELLOW FEVER IN HAVANA, CUBA | 244 ✓ |
| CHART SHOWING YELLOW FEVER CASES ON THE ISTHMUS FROM 1881 TO 1889 | 264 ✓ |
| PART OF THE PANAMA FUMIGATION BRIGADE | 284 ✓ |
| SCREENED VESTIBULE DOOR | 286 ✓ |
| A POORLY CONSTRUCTED EAVE-TROUGH | 288 ✓ |
| A CLOGGED EAVE-TROUGH | 288 ✓ |
| DIAGRAM OF A FIRMLY SUPPORTED EAVE- TROUGH | 289 ✓ |
| A FIRMLY SUPPORTED EAVE-TROUGH WITH A GOOD SLOPE | 290 ✓ |
| MOSQUITO-PROOF WATER BARREL | 290 ✓ |
| A SHORT LENGTH OF EAVE-TROUGH USED OVER A DOORWAY | 310 ✓ |

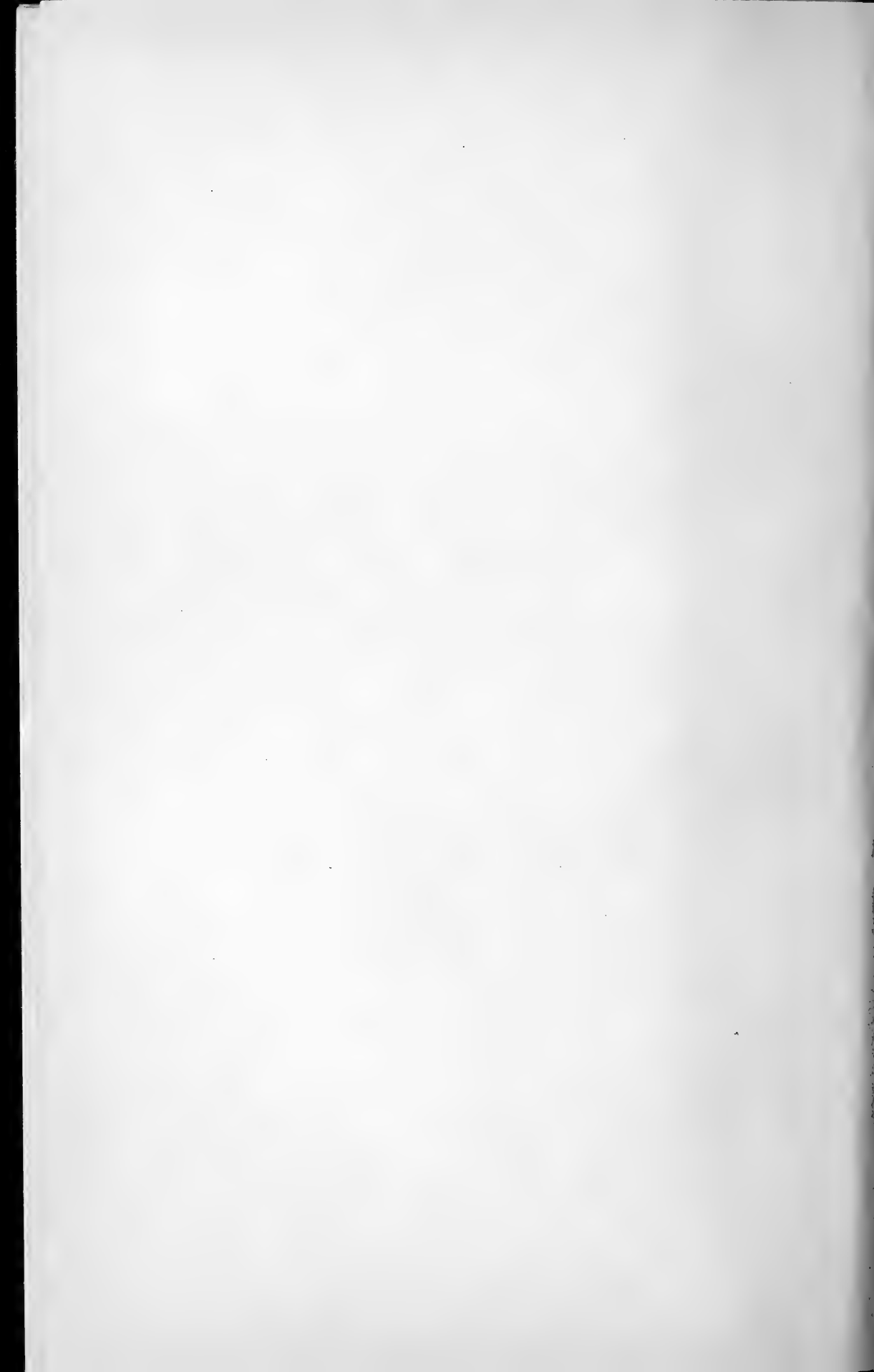

PART I
Anti-Malaria Campaign

CHAPTER I

THE STATUS OF KNOWLEDGE OF ANTI-MALARIA WORK IN 1904 AND THE CAMPAIGN AT HAVANA

THE anti-malaria work of importance accomplished previous to 1904 was that done by Colonel Gorgas in Cuba and Sir Ronald Ross in the British Colonies in the East.

The necessity for mosquito control has been appreciated since it was first demonstrated that some mosquitoes may transmit disease. Since 1900 great progress has been made in the study of the life history and habits of mosquitoes. As a result, we find remarkable differences in habits, even among species of the same genus. The determination of such facts is of great importance in the economic control or eradication of the disease-conveying species, and also in that of other genera that affect personal comfort or real estate values.

It is realized that conditions pertaining to *Anopheles* control on the Isthmus and the habits

4 The Control of Mosquitoes

of the species encountered may differ from those which will be found elsewhere, and that methods of procedure for malaria control must be modified accordingly; but if in a large territory like Panama, where conditions are most favorable for the multiplication of mosquitoes every day in the year, malaria has been controlled at a reasonable cost, the methods which accomplished the change are worth consideration.

Health officials from foreign countries have visited the Isthmus to obtain practical information in order to apply this later in malaria and yellow fever eradication abroad.

Much interest was shown by the thousands of Americans who visited the canal, and many of them asked why the same class of work could not be attempted in malarial districts in the United States, and also sought information about the work accomplished and methods of procedure.

The canal will be used by the commerce of all nations, and the progress made in sanitation in Cuba and Panama will have far-reaching effects.

The character of the work at Havana was quite different from that required on the Isthmus. The general situation resembled more closely the conditions and drainage problems occurring in the southern part of the United States, and subtropical

countries not having an excessive annual rainfall. This work was started in 1901 when the yellow fever campaign was well advanced. No anti-malaria work had been attempted elsewhere previous to the Cuban anti-malaria campaign. Ross started his practical field work in the East at the same time that work was begun in Havana. There was no previously acquired information available on the subject nor any known practical methods that could be followed, or that could assist those in charge of operations. At that time, very little was known regarding the habits and life history of *Anopheles*. It was practically all pioneer work, and improvements and methods of procedure were devised as the work progressed. Years of subsequent experience have shown that for pioneer work the scheme was excellent.

A survey was first made to determine the principal sources of *Anopheles* affecting Havana and its outlying suburbs. The most important propagation areas received first attention. Treatment of pools with oil having a paraffin base was tested. As the wet places harboring *Anopheles* were widely scattered over a large area, a covered wagon was used for transporting laborers, tools, and oil to control as much territory as possible with the small force employed. The plan of oiling was

6 The Control of Mosquitoes

arranged so that areas were not treated at regular intervals, but when *Anopheles* and other mosquito larvæ were present.

The system of inspection was well carried out, and inspections were independently checked at proper intervals. The result of *Anopheles* eradication by use of oil was fairly good, and better results were obtained than expected under the climatic and topographical conditions on the Isthmus. Very few topographical changes were being made in the vicinity of Havana. The class of labor available was very good, and fairly intelligent. The wages paid to the men in the *Anopheles* brigade were a little above average laborer's wages; this enabled the sanitary department to obtain the best class of labor and to retain it. The men used their heads as well as their hands, and worked with interest. The unit cost of ditching and of oil application was very low, and much was saved by the proper selection and payment of labor. Poor labor on anti-malaria work is most unsatisfactory, and no saving has ever been made by its employment.

It was soon found that there were disadvantages in using oil, as well as much repetition of work that could be eliminated. As rapidly as the limited appropriation would allow, the pools costing most

to control were drained or filled in, and the area under control thus increased. Each place drained or filled became one less to inspect and treat.

As time went on, the anti-*Anopheles* work consisted chiefly of draining and filling depressions in fields where water collected. The use of what is known as the "herring bone" system of ditching, the training of streams to more direct courses, and the reducing of the average wetted section of ditches, rapidly decreased the necessity for regular application of oil and for frequent inspection.

The geological formation and topographical conditions were favorable. The watercourses and areas to be treated were often distant from one another, yet the streams were of fair grade, and most of the areas needing treatment were located so that they could be drained. In some cases the impervious surface clay rested upon a coral formation. The latter was of a porous nature, and absorbed a large quantity of water in a relatively short time. In some places where there were ponds, and surface drainage was out of the question, they were connected by one or more ditches, and led to shallow wells in the coral formation, where the water was absorbed. When one well was not sufficient, two or more were made and connected, to increase the absorbent surface.

8 The Control of Mosquitoes

It was found that the bottom of these wells became clogged with clay and silt, but that the sides supplied sufficient absorbent surface to give satisfactory results. Fish were used to keep some of the wells free from mosquito life; in others, that frequently became dry, oil was used. Sometimes it was necessary to scrape well walls several times during the wet season to increase absorption.

The limited funds available did not permit the permanent lining of ditches, although in many cases it would have been more economical than treating and maintaining them for an indefinite length of time.

Anopheles production in wet areas caused by seepage occurs in Cuba, and one case near Havana was especially interesting. In 1900, a few houses were located near the top of the hill known as Jesus del Monte. Malaria prevailed among the tenants, and several deaths from pernicious malaria occurred there immediately before the undertaking of anti-malaria work. The hill appeared to be dry, and was well above the elevation of the surrounding ground. Many inspections were made to locate the source of *Anopheles* with negative results. It was supposed that they came from a distance, but an extended inspection of the surrounding country disproved this conclusion.

Finally, it was decided that the breeding place must be local, and the labor force was put in line, men eight feet apart so that every square yard of the hill would be seen, and no wet place, however small, could be missed. They marched along for some time before a piece of partially soft ground was found. There were no surface indications, such as a change in the vegetation or its color, to mark the outline of the wet area. A thin film of water was found to outcrop along a contour line, to run along the surface for a distance of about twenty feet, and then disappear into the ground. The mosquito larvæ were very plentiful. A ditch was made above the seepage outcrop line, but failed to intercept the water. Two short and deep parallel intercepting ditches were made about nine feet apart, but failed to prevent the water coming up between the two ditches. It became evident that the local porous water-bearing strata were inclined and pointed upwards, and that a distant pressure was forcing the water uphill. Ditching was out of the question. At a small cost the ground affected by the surface flow was covered with gravel and cinders to a depth of about six inches, so that the mosquitoes could not reach the water which continued in its original path.

Since that time the importance of hidden mos-

10 The Control of Mosquitoes

quito-producing areas, and their relation to the malaria situation, has been fully appreciated by those engaged in anti-malaria work. Beginners usually learn facts by temporary failure. Soon after the completion of this work the adult *Anopheles* disappeared from the vicinity. No new cases of malaria occurred. The houses that had been so long vacant because of the prevalence of malaria were again occupied. When it became known that malaria no longer existed in that locality, it was plotted into lots, and has become one of the popular residential sections of the town. Real estate values have advanced accordingly.

On low flat lands where cattle were pastured, it was found difficult to prevent *Anopheles* propagation in the water retained by hoof-prints. It became essential to prevent certain portions of fields from being used for grazing purposes during the wet season.

It was also found that plants along the shore line, as well as aquatic plants, reduced the surface velocity of water in streams and rivers to such an extent as to afford protection and harboring places for mosquito larvæ. The vegetation at the edges of ponds and streams was kept cut short. Aquatic vegetation was pulled up by the roots and removed. Small fish were very efficient larvæ

exterminators after the clearing and training of natural watercourses was accomplished. Conditions affecting growth of vegetation and algæ were less favorable in Cuba, and, in consequence, fish are of more use there as destroyers of mosquito larvæ than on the Isthmus.

Beds of watercress in the Chinese truck gardens were a prolific source of *Anopheles* in Havana. The cress beds were made by erecting small dikes on flat land, and bringing water to them by ditches from nearby streams. When the enclosure was filled, the water was left standing for long periods. In order to control the situation, small wooden sliding gates were installed at each end of the watercress beds, which were flooded at frequent intervals for short periods, and the water then allowed to escape back to the stream. This scheme, when properly carried out, practically stopped *Anopheles* development. The gardeners who refused to adopt the new method were not allowed to grow watercress. The crops grown in this manner were as vigorous as those raised in the continuously flooded patches.

Between the heavy showers that occur near Havana there are dry periods, accompanied by strong winds. When the ditches and watercourses are kept fairly free from vegetation, the heavy

showers are often beneficial, as they remove any *Anopheles* larvæ clinging to banks of ditches or cleared streams. The trade winds assist evaporation to a considerable extent, and help to dry the depressions in flat areas that hold water. The soil is of such a character that the trained streams and ditches can be kept to a proper section with less work than is necessary to attain this result at Panama. Washouts and caving of ditch banks did not happen as frequently.

In many places apparently well fitted for the support of *Anopheles* larvæ, they were absent; yet lived and developed when placed therein as an experiment. The reason why *Anopheles* eggs are not laid in certain areas apparently in every way similar to those in which larvæ are found is yet unexplained. The season of *Anopheles* production in Cuba is much shorter and less continuous than on the Isthmus. It was largely due to these causes that oiling at irregular intervals gave satisfactory results. Conditions of soil, topography, and climate there do not favor the rapid and continuous production of mosquitoes as much as in the Canal Zone.

The drainage connected with the Havana campaign was completed within a year of the time anti-malaria work began, and its maintenance

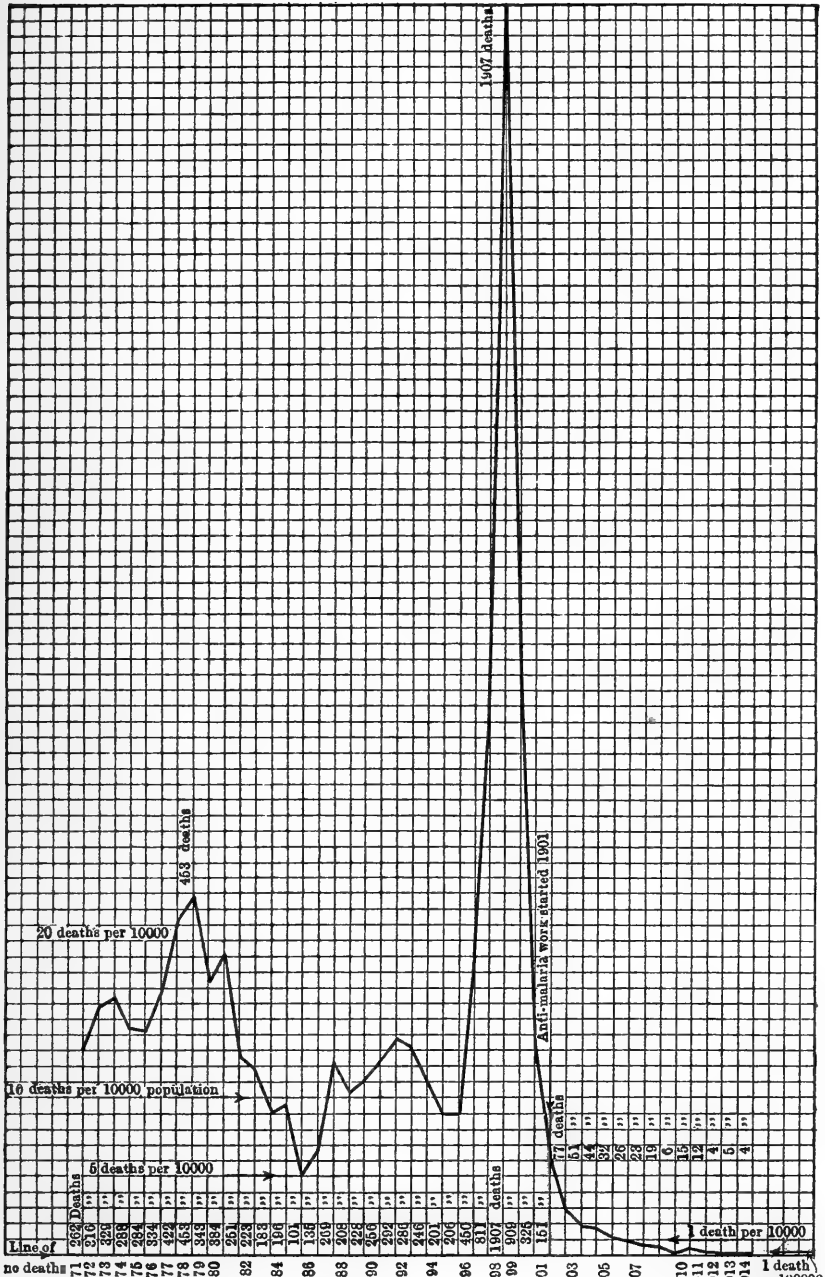

Deaths caused by Malaria in Havana 1871-1914
Anti Malaria Campaign was Started in 1901 - Note the Curve from 1901 to 1914

- 1871 to 1880 - 3415 deaths
- 1881 to 1890 - 2050 "
- 1891 to 1900 - 5633 "
- 1901 to 1910 - 444 " (for 4 years)
- 1911 to 1914 - 25 " "

1871 to 1914 (12,567 " in 44 years)

Chart showing malaria death-rate at Havana 1871 to 1914.

14 The Control of Mosquitoes

since then has been mostly a question of economy. The sanitary department of the Republic of Cuba has continued the work started by Colonel Gorgas and deserves great praise for the excellent record it has maintained.

To review the results of the Havana campaign, the records show:

Population of Havana, 350,000.

From 1890 to 1900,—5643 deaths from malaria.

From 1900 to 1910,—444 deaths from malaria, with a largely increased population.

It is interesting to note the rapidity with which malaria control was accomplished, as shown by the following table:

TABLE OF DEATHS FROM MALARIA IN HAVANA, CUBA,
1901 TO 1912

| <i>Year</i> | <i>No. of Deaths</i> | <i>Year</i> | <i>No. of Deaths</i> | <i>Year</i> | <i>No. of Deaths</i> |
|-------------|----------------------|-------------|----------------------|-------------|----------------------|
| 1901 | 151 | 1905 | 32 | 1909 | 6 |
| 1902 | 77 | 1906 | 26 | 1910 | 15 |
| 1903 | 51 | 1907 | 23 | 1911 | 12 |
| 1904 | 44 | 1908 | 19 | 1912 | 4 |

Malarial fever is almost eliminated from Havana and its suburbs.

The cost of maintaining this condition is very

low, and might be further reduced by lining the bottoms of the small streams and ditches with reinforced concrete, in order to lower the cost of cleaning and ditch maintenance.

CHAPTER II

THE SITUATION ON THE ISTHMUS IN 1904, BEFORE AMERICAN OCCUPATION

PRESIDENT ROOSEVELT appointed Colonel W. C. Gorgas as Chief Sanitary Officer of the Isthmian Canal Commission, and it was under his leadership that the first sanitary survey was made. He established temporary headquarters for his first assistants at Ancon, where the French had terraced the hillsides and had established a hospital of about twenty wards. The situation selected by the French was excellent, but to-day, from our more advanced knowledge, we can readily understand why their sick-rate was so high, and can also realize that it would have been equally so under an American administration working with the limited knowledge pertaining to malaria previous to the year 1900.

At the time the American government assumed control of the Canal Zone, there was a succession of villages strung along the line of the canal; most

of them close to the camps occupied by the laborers during the days of the French Canal Company. They were located apparently with reference to proximity to work and many were near a convenient source of water supply. At the time these camps were established, nothing was known regarding the transmission of malaria. Better locations were available, but they were in nearly all cases far distant from the canal. Some of the camps had been abandoned altogether and could not be reached without cutting pathways through the jungle.

In some cases, where the rafters had decayed and the roofs had collapsed, trees with a diameter of ten inches were growing inside the buildings. The natural watercourses were overgrown by dense jungle, and nearly all of the villages were practically in the jungle itself. The French engineers had, for drainage purposes, placed masonry lined ditches near some settlements, and the work was excellent; it is in as good condition to-day as at the date of completion, and will probably remain so for many years to come.

In June, 1904, about 1100 laborers were employed in canal work at Culebra; they lived in the adjacent villages, and very few isolated houses existed in the bush. Many of the old French

18 The Control of Mosquitoes

buildings were occupied by laborers who had remained after the financial failure of the French company.

Malarial fever was prevalent among these people, and they had neither the knowledge nor the means to combat it. At Paraiso, in September, 1904, there was a population of 350 of which 42 were sick in bed. At Bohio, a village fifteen miles south of Colon, blood samples were taken from natives, and eighty per cent. showed malaria infection. But even this poor and ignorant class of people took steps to do the best they knew how; they prayed for deliverance from fever and shunned certain localities in which the sick-rate was abnormally high as compared with the prevailing high fever rate.

At Corozal, the nearest village to Panama, only one house was occupied, and many colored people told us that "to live there is to be sick and die."

The situation at Ancon Hospital was extremely interesting. The grounds were magnificent; there were palms, beautiful crotons, and other decorative plants near the wards and on the terrace, but the insects, and especially the ants, destroyed them repeatedly. The gardeners partially overcame this difficulty by placing hollow earthenware



Ant-guards: Old hospital at Ancon

rings of a semi-spherical section around each plant. They were kept filled with water and of course contained many larvæ of both *Aedes calopus* and *Anopheles* as well as algæ, vegetable debris, etc.

The ditches near the wards were lined with field stone; the spaces between the stones were filled with earth and grass which retarded the current of water. These ditches discharged onto the grass-covered, clayey soils, and pools remained there, distributed over a large area.

The natural topography of the hill gave a fairly steep slope with a more gently sloping bench below it. The highest part of the hill is about six hundred feet above sea level. The water absorbed by the upper part of the hill came to the surface at a lower level on a clay-like formation covered with grass, making the hillside resemble a bog in many places. The outcrop of water, which oozed slowly from the ground, often followed the contour of the hill for a considerable distance. Consequently the area immediately below that contour was wet almost continually.

There was a cow pasture on the top of the hill, and throughout the rainy season the hoof-prints remained wet or full of water. Ditches of varying widths ran down the slope, and the water spread

over the ground and sometimes did not return to the lower part of the ditch. In addition, the foot of the hill formed the shore line of an extensive swamp. These adverse conditions, and wet areas covered with vegetation, encouraged *Anopheles*. A more prolific source would be hard to imagine.

The number of adult *Anopheles* present in the hospital wards and buildings corresponded with the numerous favorable propagation areas on and near the hillside. At night, comfort was impossible and mosquito bars indispensable. Not a single building was screened. The malaria and yellow fever patients had been accessible to *Anopheles* and *Aedes calopus*, and the other patients were near them. The patients in wards were located according to nationality instead of according to the nature of their illness. Had it been intended to spread yellow fever and malaria with the greatest rapidity among the patients as soon as they arrived, no better plan could have been adopted. Similar conditions have existed in other tropical countries; in fact, were customary in past years.

Before sanitary work was fairly under way, with one or two exceptions, the small hospital sanitary force was down with malaria. During the first year of work, all the force suffered. At one time



A ditch at Ancon: weeds retarding water flow

it became necessary for the sanitary inspectors to be employed all night in clerical work. The *Anopheles* were so numerous that night work had to be done in relays; one set of men using fans to protect those working. We were two thousand miles from the source of supplies and had to wait for screening, its installation, necessary supplies, etc.

When the hospital was first opened and treatment given without charge to employees, the native laborers who had known of the suffering and deaths in previous years at Ancon refused to go to the hospital, stating that they "preferred to die at home." We could readily sympathize with their ideas, knowing what had happened in the past. No attempt was made to approximate the number of *Anopheles* present. The prevailing species was *Anopheles albimanus*. Inside one of the buildings near the hospital, fifty-four adult *Anopheles* were noted on the upper panel of a screen door.

It was desirable to know the time of the day or night when the *Anopheles* would take blood. In July of 1904, men were dressed in white clothing and dark coats and made to lie on cots in an un-screened ward at Ancon. They were furnished with pill-boxes and a clock. Each time a mos-

quito bit them, or tried to, it was captured and placed in a pill-box and the date and hour written on the box. It was found at that time that *Anopheles* in the ward attacked men at rest at all hours of the day, and at night they became too numerous to make the work pleasant. It was noticed that they did not bite as freely near the doorway, where there was more light during the daytime, and that they absolutely refused to follow a man out into the bright rays of the sun.

Before anti-malaria work was begun, a preliminary survey was made and *Anopheles* production areas were found near every existing settlement, as well as all abandoned camps that had been used by the French. The greater part of these areas was covered with dense jungle, and their extent could not be at once determined. There were numerous seepage outcrops and their output varied according to the rainfall; and probably the contour line of seepage varied also. The character of the soil was often such as to retain the rainfall for relatively long periods, and innumerable small depressions existed, which might produce mature pupæ or not according to weather conditions. The survey showed that it would be necessary to clear off large areas of jungle near settlements before any effective results



Jungle covering a stream entering the Chagres River at Bohio

could be obtained, and it was decided to begin work at the camps that were first to be occupied by the laborers and American forces. It was thought also that oiling of wet areas would be attended with less successful results than in the Cuban campaign, because the rainfall of the Isthmus was often sufficiently continuous to remove all traces of oil before it had had much effect on the mosquito larvæ. When pathways were cut through the jungle new mosquito producing areas were found.

The statistics of the days of the French Canal Company are incomplete, and include only a portion of the deaths due to malaria, as only cases in hospitals, or patients able to pay for hospital treatment, were recorded.

In the city of Panama, which was not so badly infested with *Anopheles* as Colon, the malaria sick-rate and death-rate were high. The number of deaths recorded as due to malarial fever was:

| <i>Date</i> | <i>Number of Deaths</i> | <i>Population</i> |
|-------------------|-------------------------|-------------------|
| From 1884 to 1893 | | 20,000 to |
| inclusive | 3504 | 22,000 |
| 1885 | 687 | 20,276 |

During 1906, the year of highest malaria sick-rate of the American period of occupation, among

21,934 malarial fever patients entering the hospitals, 195 deaths occurred, or less than one per cent. of the cases. It can be readily understood from these death-rates how prevalent infection was in the city of Panama before 1904. The hospital physicians who were at Colon and Panama previous to 1904 state that over seventy-five per cent. of all hospital patients had malaria. Of course, in the villages out in the Canal Zone surrounded by jungle, breeding places for *Anopheles* were quite numerous and close to the houses. The question of controlling malaria appeared at first sight to be utterly hopeless. The United States Public Health Reports describe the situation as follows:

From Panama to Colon, a distance of forty-seven miles, along the railroad there are many villages, in fact almost a continuous settlement the entire distance, the total estimated population being 15,000 in January, 1904. The population is almost entirely negro and Chinese. All the villages are filthy, without regulations or restrictions, without sewers, and having the usual water supply of the country, viz., rain-water during the wet season, and water from streams during the dry season. No attention is paid to the wholesomeness of the source of the water supply. Mosquitoes are prevalent in all these villages, breeding in rainwater barrels, in the swamps, along the streams, and in ponds. Malaria, elephantiasis, and beriberi

are always to be found, and yellow fever and smallpox will occur when favorable clinical material presents itself, unless proper precautions are taken.

In order to obtain certain data concerning malaria transmission, an experimental station was established at Ancon, and non-immunes were isolated there for the experiments, but so many *Anopheles al imanus* were present that it was extremely difficult to prevent natural malaria transmission.

Low lying flat areas occurred for a distance of six miles inland from the Pacific terminal and to a still greater distance from the Atlantic Coast. Much of this area was affected by the highest tides, and *Anopheles* larvæ were present in streams on steep hillsides as well as on the lowlands.

The preliminary survey showed that *Anopheles* and other mosquitoes were present near all the camps, but the impassable jungle made it impossible to determine the extent of the propagation areas and it was evident that considerable clearing would have to be done to obtain the data desired. Innumerable small puddles were everywhere, and their possibilities as mosquito producers depended upon the frequency of the successive showers. The rapidity of growth of vegetation was remarkable, and showed that its control would be an important

26 The Control of Mosquitoes

factor in the anti-malaria campaign. Algæ that protected the larvæ from their natural enemies was often found and appeared to develop in a few day's time. It was evident that work would have to be done on an extensive scale and that the climatic conditions would make the campaign a strenuous one. One apparently discouraging feature was the frequent occurrence of showers that removed oil applied to breeding areas before it could accomplish its purpose.

CHAPTER III

METEOROLOGICAL AND TOPOGRAPHICAL CONDITIONS. TOPOGRAPHICAL CHANGES AND THEIR BEARING ON ISTHMIAN ANOPHELES

THE Isthmian Canal Zone has a tropical climate, high humidity, heavy rainfall, and a short dry season of four months or less. The continental divide occurs at Culebra about twelve miles from the Pacific canal terminal. North of Culebra all drainage goes to the Atlantic Ocean through the Chagres Valley. The attached Table No. 1 describing the air temperature for 1912 shows the seasonal variation to be very slight, with no excessive heat, and no marked difference of temperature at different points in the Zone. It always remains within limits that are favorable to the development of mosquito life.

The yearly rainfall is not equal in all parts of the Canal Zone. The extremes are noted at Colon and Panama. On lands adjacent to the Pacific coast, near the city of Panama, the precipitation

TABLE No. 1.—*Monthly rainfall on the Isthmus of Panama, 1912-13, and station averages.*

[Values in inches.]

| Station. | July. | August. | Septem-ber. | October. | Novem-ber. | Decem-ber. | January. | February. | March. | April. | May. | June. | Annual. |
|------------------------|-------|---------|-------------|----------|------------|------------|----------|-----------|--------|--------|-------|-------|---------|
| Ancon: | | | | | | | | | | | | | |
| 1912 for 15 years..... | 10.25 | 6.33 | 8.38 | 17.89 | 6.38 | 3.27 | T. | 0.08 | 0.01 | 2.68 | 10.71 | 5.80 | 71.78 |
| 1913 for 15 years..... | 8.16 | 7.53 | 7.46 | 10.92 | 10.45 | 4.18 | 0.63 | .22 | .43 | .03 | 8.27 | 8.15 | |
| Average for 15 years.. | 9.76 | 6.79 | 10.01 | 15.75 | 6.14 | 4.94 | 1.02 | .86 | .78 | 2.76 | 8.98 | 8.15 | 71.25 |
| Balboa: | | | | | | | | | | | | | |
| 1912 for 14 years..... | 9.88 | 7.55 | 6.79 | 9.55 | 9.09 | 5.98 | .00 | .18 | .00 | 2.88 | 9.56 | 5.88 | 71.89 |
| 1913 for 14 years..... | 8.37 | 11.35 | 14.45 | 15.44 | 11.89 | 6.75 | .78 | .19 | .00 | .08 | 8.04 | 7.15 | |
| Average for 14 years.. | 9.20 | 9.21 | 11.04 | 12.99 | 12.23 | 8.16 | 1.11 | .57 | .84 | 4.09 | 7.22 | 7.98 | 70.62 |
| Miraflores: | | | | | | | | | | | | | |
| 1912 for 4 years..... | 11.54 | 9.51 | 10.76 | 10.48 | 8.43 | 3.91 | .00 | .34 | .00 | 4.79 | 7.60 | 7.51 | 38.49 |
| 1913 for 4 years..... | 9.11 | 8.88 | 8.91 | 12.54 | 10.99 | 7.38 | 2.65 | .22 | .00 | .79 | 12.33 | 9.49 | |
| Average for 4 years.. | 9.11 | 13.19 | 15.10 | 9.46 | 7.01 | 4.04 | 2.01 | 1.65 | .90 | 3.78 | 9.22 | 10.83 | 91.22 |
| Pedro Miguel: | | | | | | | | | | | | | |
| 1912 for 5 years..... | 11.04 | 10.34 | 11.18 | 13.10 | 11.12 | 5.93 | .00 | .07 | .00 | 4.23 | 6.92 | 9.69 | 75.71 |
| 1913 for 5 years..... | 9.11 | 8.88 | 8.91 | 12.54 | 10.99 | 7.38 | 1.10 | .07 | .00 | 1.04 | 13.48 | 9.00 | |
| Average for 5 years.. | 9.11 | 13.19 | 15.10 | 9.46 | 7.01 | 4.04 | .99 | 1.08 | .44 | 3.62 | 10.59 | 10.31 | 84.84 |
| Rio Grande: | | | | | | | | | | | | | |
| 1912 for 8 years..... | 10.12 | 12.88 | 14.12 | 10.15 | 7.59 | 4.87 | .03 | .33 | .03 | 3.03 | 7.18 | 6.63 | 75.14 |
| 1913 for 8 years..... | 11.04 | 10.34 | 11.18 | 13.10 | 11.12 | 5.93 | 2.09 | .43 | .30 | 1.12 | 12.33 | 8.03 | |
| Average for 8 years.. | 9.52 | 10.58 | 11.23 | 11.54 | 12.30 | 7.68 | 1.35 | .68 | .33 | 3.52 | 10.91 | 9.34 | 88.84 |
| Culebra: | | | | | | | | | | | | | |
| 1912 for 22 years..... | 10.87 | 13.77 | 14.14 | 11.57 | 7.06 | 3.46 | .05 | .33 | .02 | 3.14 | 8.15 | 7.57 | 78.99 |
| 1913 for 22 years..... | 10.87 | 10.43 | 11.11 | 14.14 | 13.29 | 6.64 | 1.57 | .78 | .57 | .71 | 11.74 | 9.10 | |
| Average for 22 years.. | 9.52 | 10.58 | 11.23 | 11.54 | 12.30 | 7.68 | 1.75 | .56 | .68 | 3.80 | 11.16 | 8.86 | 89.66 |
| Camacho: | | | | | | | | | | | | | |
| 1912 for 6 years..... | 10.87 | 13.77 | 14.14 | 11.57 | 7.06 | 3.46 | .04 | .65 | .06 | 2.44 | 6.15 | 7.77 | 77.98 |
| 1913 for 6 years..... | 10.87 | 10.43 | 11.11 | 14.14 | 13.29 | 6.64 | 1.60 | .44 | .00 | 2.52 | 16.03 | 8.65 | |
| Average for 6 years.. | 9.15 | 10.53 | 13.78 | 12.44 | 7.24 | 8.71 | 1.20 | .82 | .58 | 3.52 | 11.38 | 10.11 | 94.09 |
| Empire: | | | | | | | | | | | | | |
| 1912 for 8 years..... | 14.27 | 16.64 | 12.75 | 13.60 | 6.56 | 3.63 | .01 | .34 | .01 | 2.64 | 6.21 | 8.50 | 74.56 |
| 1913 for 8 years..... | 10.44 | 12.20 | 10.50 | 12.80 | 12.26 | 6.97 | 1.67 | .79 | .22 | .90 | 11.74 | 11.48 | |
| Average for 8 years.. | 9.32 | 9.72 | 8.31 | 14.05 | 10.99 | 5.57 | .73 | .55 | .43 | 3.56 | 9.64 | 8.27 | 81.14 |
| Gambos: | | | | | | | | | | | | | |
| 1912 for 30 years..... | 9.96 | 11.04 | 11.42 | 12.42 | 12.53 | 6.42 | .06 | 1.11 | .10 | .77 | 7.94 | 11.64 | 89.07 |
| 1913 for 30 years..... | 9.22 | 11.96 | 11.42 | 12.42 | 12.53 | 6.42 | 2.65 | .68 | .08 | 1.07 | 15.13 | 8.02 | |
| Average for 30 years.. | 9.22 | 11.96 | 11.42 | 12.42 | 12.53 | 6.42 | 1.84 | .85 | .84 | 3.54 | 10.91 | 9.70 | 92.85 |
| Juan Mina: | | | | | | | | | | | | | |
| 1912 for 2 years..... | 9.22 | 11.96 | 11.42 | 12.42 | 12.53 | 6.42 | .15 | .90 | .07 | .86 | 10.86 | 12.65 | 88.24 |
| 1913 for 2 years..... | 9.22 | 11.96 | 11.42 | 12.42 | 12.53 | 6.42 | 1.01 | .94 | .36 | .54 | 13.20 | 9.67 | |
| Average for 2 years.. | 9.22 | 11.96 | 11.42 | 12.42 | 12.53 | 6.42 | 1.10 | 1.14 | .14 | 1.70 | 13.38 | 10.88 | 91.31 |

| | | | | | | | | | | | | | |
|---------------------------|-------|-------|-------|-------|-------|-------|-------|-------|-------|-------|-------|-------|--------|
| Alhuelna: | 10.17 | 12.87 | 9.12 | 13.52 | 9.62 | 2.20 | .08 | .33 | .02 | .20 | 13.43 | 12.17 | 88.73 |
| 1912 for 13 years..... | | | | | | | .96 | .22 | .08 | .72 | 12.63 | 11.51 | |
| 1913 for 13 years..... | 13.23 | 13.08 | 11.60 | 13.52 | 14.24 | 7.08 | 1.23 | .79 | .66 | 3.22 | 12.75 | 12.86 | 104.26 |
| Average for 13 years..... | | | | | | | | | | | | | |
| El Viga: | 13.95 | 14.96 | 10.10 | 14.85 | 10.79 | 1.53 | .08 | .62 | .08 | .37 | 12.81 | 14.51 | 94.65 |
| 1912 for 4 years..... | | | | | | | .78 | .86 | .10 | .98 | 13.35 | 10.80 | |
| 1913 for 4 years..... | 12.99 | 13.44 | 12.78 | 16.12 | 16.45 | 6.52 | 1.22 | 2.78 | .85 | 2.10 | 12.38 | 13.89 | 111.50 |
| Average for 4 years..... | | | | | | | | | | | | | |
| Gorgona: | 10.46 | 14.82 | 12.80 | 16.89 | 7.15 | 4.80 | .20 | .35 | .02 | .71 | 8.03 | 14.82 | 91.05 |
| 1912 for 8 years..... | | | | | | | 3.17 | .30 | .03 | 3.48 | 13.82 | 9.48 | |
| 1913 for 8 years..... | 11.21 | 12.21 | 12.46 | 13.53 | 13.11 | 7.03 | 1.85 | .86 | .98 | 2.87 | 12.35 | 9.52 | 97.98 |
| Average for 8 years..... | | | | | | | | | | | | | |
| Frijoles: | 9.87 | 13.63 | 11.93 | 19.20 | 15.88 | 5.65 | .67 | 3.01 | .10 | 1.19 | 10.28 | 13.25 | 104.63 |
| 1912..... | | | | | | | | 3.03 | .29 | 2.44 | 21.07 | 8.72 | |
| 1913..... | | | | | | | | | | | | | |
| Average..... | | | | | | | | | | | | | |
| Trinidad: | 11.80 | 7.68 | 11.36 | 16.80 | 20.36 | 5.61 | 1.38 | 1.15 | .28 | 3.03 | 11.79 | 11.80 | 103.04 |
| 1912 for 5 years..... | | | | | | | 3.45 | 1.80 | 1.11 | 2.52 | 17.73 | 11.20 | |
| 1913 for 5 years..... | 9.52 | 11.28 | 12.20 | 15.17 | 21.91 | 11.21 | 3.32 | 2.85 | 3.17 | 5.20 | 14.08 | 11.08 | 120.99 |
| Average for 5 years..... | | | | | | | | | | | | | |
| Monte Lirio: | 11.60 | 8.15 | 9.39 | 21.17 | 16.35 | 5.24 | 2.14 | 3.32 | .24 | 1.29 | 8.34 | 13.51 | 100.74 |
| 1912 for 5 years..... | | | | | | | 3.57 | 2.52 | .60 | 3.54 | 16.29 | 10.71 | |
| 1913 for 5 years..... | 14.13 | 11.14 | 12.11 | 16.60 | 24.46 | 11.09 | 3.61 | 4.35 | 3.76 | 4.88 | 14.34 | 13.62 | 134.09 |
| Average for 5 years..... | | | | | | | | | | | | | |
| Gatun: | 11.84 | 11.98 | 7.84 | 14.52 | 19.18 | 9.82 | .91 | 2.38 | .55 | 4.18 | 13.83 | 14.80 | 111.83 |
| 1912 for 6 years..... | | | | | | | 4.63 | 2.92 | 1.01 | 5.38 | 17.06 | 10.70 | |
| 1913 for 6 years..... | 12.41 | 14.34 | 9.70 | 16.62 | 22.40 | 13.38 | 3.83 | 2.40 | 2.91 | 4.05 | 15.66 | 13.78 | 131.43 |
| Average for 6 years..... | | | | | | | | | | | | | |
| Brazos Brook: | 16.85 | 14.42 | 9.11 | 17.97 | 21.86 | 9.63 | .61 | 2.26 | .53 | .85 | 11.45 | 19.12 | 124.66 |
| 1912 for 6 years..... | | | | | | | 5.72 | 4.20 | .71 | 5.23 | 18.77 | 12.17 | |
| 1913 for 6 years..... | 16.88 | 14.68 | 11.57 | 15.19 | 24.69 | 14.19 | 3.52 | 2.30 | 3.24 | 3.16 | 13.18 | 15.89 | 138.49 |
| Average for 6 years..... | | | | | | | | | | | | | |
| Colon: | 13.13 | 9.87 | 12.23 | 17.65 | 21.81 | 11.47 | .28 | 1.81 | .66 | .75 | 12.03 | 15.90 | 117.89 |
| 1912 for 42 years..... | | | | | | | 6.71 | 1.75 | .79 | 2.69 | 22.60 | 11.81 | |
| 1913 for 42 years..... | 16.38 | 15.01 | 12.53 | 44.29 | 21.86 | 12.31 | 3.96 | 1.47 | 1.67 | 4.08 | 12.41 | 13.35 | 129.32 |
| Average for 42 years..... | | | | | | | | | | | | | |
| Porto Bello: | 24.21 | 14.15 | 15.03 | 17.01 | 25.82 | 11.52 | .67 | 1.64 | .60 | .54 | 16.65 | 19.77 | 147.61 |
| 1912 for 5 years..... | | | | | | | 5.84 | 2.03 | 1.17 | 2.34 | 9.00 | 9.00 | 30.51 |
| 1913 for 5 years..... | 19.56 | 17.65 | 13.66 | 11.26 | 29.60 | 22.33 | 7.84 | 4.55 | 2.76 | 6.56 | 15.18 | 17.55 | 163.50 |
| Average for 5 years..... | | | | | | | | | | | | | |

One year only.

NOTE.—Station averages do not include records for the year 1913.

30 The Control of Mosquitoes

is from seventy to eighty inches per year. Toward the divide the rainfall increases, and between Culebra and Colon is very heavy, increasing as the Atlantic coast is approached. The annual precipitation at Colon is between 120 and 180 inches.

The country along the line of the Canal is low and near tide level for a distance of six miles from the Pacific, and fifteen from the Atlantic ocean. The remainder of the country is thickly studded with hills and contains numerous springs, seepage outcrops, swamps, and streams. The Canal approximately follows the line of the Chagres River as far as the divide at Culebra Cut, and then down the valley of the Rio Grande to the Pacific. There is very little porous soil on the Isthmus, and a large part of the surface soil is of a claylike character and is so densely clothed with luxuriant vegetation that travel is impossible except along the trails, which if not constantly used soon become overgrown and disappear. The lands immediately adjacent to the Canal produce more mosquitoes than places a mile or more east and west of it. There are extensive areas toward the Canal Zone boundary line and in the Republic of Panama in which *Anopheles* do not exist.

The meteorological tables, on the pages previously referred to, show the large percentage of

TABLE No. 2.—Monthly rainfall by sections, Canal Zone— Year 1912 and averages.

[Values in inches.]

| Month | Pacific section. | | Central section. | | Atlantic section. | |
|----------------|------------------|----------|------------------|----------|-------------------|----------|
| | 1912 | Average. | 1912 | Average. | 1912 | Average. |
| January..... | 0.01 | 1.30 | 0.44 | 1.62 | 0.62 | 4.79 |
| February..... | .23 | .97 | 1.10 | 1.69 | 2.02 | 2.68 |
| March..... | .01 | .66 | .09 | 1.21 | .58 | 2.64 |
| April..... | 3.52 | 3.55 | 1.51 | 3.65 | 1.58 | 4.46 |
| May..... | 8.39 | 9.37 | 9.45 | 12.29 | 13.49 | 14.11 |
| June..... | 7.10 | 9.32 | 11.65 | 10.99 | 17.34 | 15.14 |
| July..... | 9.81 | 9.48 | 11.11 | 11.22 | 16.51 | 16.31 |
| August..... | 9.43 | 8.70 | 12.45 | 11.89 | 12.60 | 15.42 |
| September..... | 11.74 | 9.08 | 12.16 | 11.37 | 11.05 | 11.86 |
| October..... | 13.80 | 11.82 | 14.81 | 13.99 | 16.79 | 14.34 |
| November..... | 7.97 | 10.78 | 11.03 | 15.54 | 22.17 | 24.64 |
| December..... | 4.58 | 6.33 | 3.88 | 7.90 | 10.61 | 15.55 |
| Year..... | 76.58 | 81.36 | 89.68 | 103.36 | 125.36 | 141.94 |

NOTE.—Means are based on the records from 5 stations in the Pacific section, 11 in the Central section, and 4 in the Atlantic section. All available records are used in computing averages.

TABLE No. 3.—Maximum rainfall in Canal Zone Oct. 1, 1905, to June 30, 1913.

| Stations. | Maximum rainfall. | | | | | |
|------------------------------|-------------------|---------------|---------|----------------|------------------------|----------------------------|
| | 5 minutes. | | 1 hour. | | 24 hours. ¹ | |
| | Inches. | Date. | Inches. | Date. | Inches. | Date. |
| Ancon (Oct. 1, 1905)..... | 0.64 | Aug. 7, 1908 | 3.98 | Oct. 9, 1911 | 7.23 | May 12-13, 1912. |
| Balboa (June 10, 1906).... | .90 | May 12, 1912 | 5.86 | June 2, 1906 | 7.57 | Nov. 16-17, 1906. |
| Pedro Miguel (Jan. 1, 1908). | .60 | Nov. 11, 1908 | 3.30 | Aug. 27, 1908 | 4.56 | Sept. 30-Oct. 1, 1909. |
| Rio Grande (Dec. 29, 1905). | .75 | July 24, 1908 | 3.10 | Sept. 21, 1912 | 6.00 | Dec. 2-3, 1906. |
| Culebra (July 1, 1906)..... | .64 | May 2, 1908 | 3.69 | Oct. 16, 1907 | 5.55 | Dec. 3, 1906. ² |
| Empire (July 18, 1906).... | .60 | July 25, 1906 | 3.63 | Oct. 1, 1909 | 6.15 | Do. |
| Gamboa (Nov. 18, 1905).... | .59 | July 27, 1908 | 3.32 | May 11, 1911 | 6.56 | Dec. 2-3, 1906. |
| Alhajuela (Mar. 31, 1907)... | .60 | July 20, 1909 | 3.40 | Dec. 28, 1909 | 8.19 | Dec. 3, 1906. ³ |
| Gatun (Aug. 24, 1907)..... | .62 | Aug. 3, 1912 | 3.82 | May 26, 1910 | 10.48 | Do. |
| Colon (Oct. 1, 1905)..... | .64 | Aug. 25, 1909 | 4.90 | Oct. 8, 1909 | 8.53 | Dec. 2-3, 1906. |
| Porto Bello (May 1, 1908)... | * 2.48 | Nov. 29, 1911 | 4.53 | Nov. 29, 1911 | 10.86 | Dec. 23-29, 1909. |

¹ Maximum fall in any 24 consecutive hours.

² No automatic record on this date; total for 24 hours ending at noon.

³ Approximate; automatic record indistinct, due to unusually excessive rate of fall.

NOTE.—Dates in parentheses opposite station names refer to installation of automatic rainfall registers.

TABLE No. 4.—Hourly distribution of rainfall in Canal Zone, year 1912.

[Values in inches.]

| Station. | Total annual rainfall. | Rainfall during working hours, 7 a. m. to 5 p. m. | | Hourly rainfall. | | | |
|-------------------|------------------------|---|--------------------|------------------|---------------------|----------------------------|---------------------|
| | | Amount. | Per cent of total. | Maximum. | | Minimum. | |
| | | | | Hour of maximum. | Accumulated amount. | Hour of minimum. | Accumulated amount. |
| Ancon..... | 71.78 | 45.37 | 63 | 2-3 p. m... | 10.27 | 1-2 a. m... | 0.32 |
| Balboa..... | 71.89 | 44.34 | 62 | 2-3 p. m... | 10.69 | 1-2 a. m... | .29 |
| Pedro Miguel..... | 75.71 | 57.95 | 77 | 2-3 p. m... | 14.88 | 2-3 a. m... | .16 |
| Rio Grande..... | 75.14 | 53.13 | 71 | 2-3 p. m... | 15.15 | 4-5 a. m., and 11 p. m. | .28 |
| Culebra..... | 78.99 | 43.45 | 55 | 2-3 p. m... | 14.51 | 11 p. m... | .27 |
| Gamboa..... | 89.07 | 68.14 | 77 | 3-4 p. m... | 16.20 | 10-11 p. m. | .27 |
| Alhajuela..... | 83.73 | 65.70 | 78 | 2-3 p. m... | 15.44 | 1-2 a. m... | .34 |
| Gatun..... | 111.83 | 48.28 | 43 | 3-4 p. m... | 8.50 | 9-10 a. m... | 2.56 |
| Colon..... | 117.59 | 44.26 | 38 | 5-6 a. m... | 8.25 | 8-9 p. m... | 1.91 |
| Porto Bello..... | 147.61 | 72.58 | 49 | 2-3 p. m... | 12.51 | 6-7 p. m... | 2.65 |

32 The Control of Mosquitoes

rainy days that occur each year, and particularly during certain months. At Panama from July to

TABLE No. 5.—Monthly meteorological data—Ancon, Canal Zone, year 1912.

| Month. | Atmospheric pressure (inches). | | Air temperature (degrees Fahrenheit). | | | | | | | | Mean wet thermometer. | Mean temperature, dew point. | Mean relative humidity (Per cent). |
|----------------|--------------------------------|------------|---------------------------------------|----------|------|---------------|----------|------|---------------|----------------------|-----------------------|------------------------------|------------------------------------|
| | Station. ¹ | Sea level. | Monthly mean. | Maximum. | Day. | Mean maximum. | Minimum. | Day. | Mean minimum. | Maximum daily range. | | | |
| January..... | 29.742 | 29.838 | 80.6 | 93 | 22 | 91 | 68 | 26 | 71 | 23 | 72 | 70 | 82 |
| February..... | 29.762 | 29.858 | 81.3 | 94 | 19 | 91 | 66 | 1 | 71 | 26 | 72 | 70 | 82 |
| March..... | 29.749 | 29.844 | 83.0 | 96 | 7 | 94 | 69 | 12 | 72 | 24 | 73 | 71 | 77 |
| April..... | 29.770 | 29.865 | 82.1 | 97 | 7 | 92 | 69 | 2 | 72 | 26 | 74 | 72 | 78 |
| May..... | 29.732 | 29.828 | 82.0 | 96 | 7 | 90 | 71 | 20 | 74 | 21 | 76 | 75 | 87 |
| June..... | 29.742 | 29.837 | 80.8 | 94 | 21 | 89 | 70 | 16 | 73 | 23 | 75 | 75 | 90 |
| July..... | 29.728 | 29.823 | 80.6 | 94 | 27 | 88 | 70 | 14 | 73 | 19 | 75 | 74 | 91 |
| August..... | 29.728 | 29.824 | 80.2 | 94 | 31 | 88 | 69 | 7 | 72 | 21 | 75 | 75 | 90 |
| September..... | 29.726 | 29.822 | 79.4 | 92 | 9 | 87 | 68 | 24 | 72 | 20 | 75 | 74 | 91 |
| October..... | 29.735 | 29.830 | 79.0 | 92 | 5 | 86 | 69 | 29 | 72 | 19 | 75 | 74 | 93 |
| November..... | 29.736 | 29.831 | 79.0 | 91 | 26 | 86 | 69 | 17 | 74 | 21 | 74 | 74 | 92 |
| December..... | 29.722 | 29.818 | 80.8 | 93 | 5 | 90 | 69 | 18 | 72 | 21 | 74 | 73 | 89 |
| Year..... | 29.739 | 29.835 | 80.7 | 97 | 47 | 89.3 | 66 | * 1 | 72.3 | 26 | 74.2 | 73.1 | 86.8 |

| Month. | Precipitation (inches). | | | Wind. | | | | Number of days. | | | | | |
|----------------|-------------------------|----------|-------------|-------------------------|-----------------------|-------------------|------------|-----------------|--------|--------------|---------|----------------|----------------------|
| | Monthly total. | Normal.* | Rainy days. | Total movement (miles). | Prevailing direction. | Maximum velocity. | | | Clear. | Part cloudy. | Cloudy. | Thunderstorms. | Average cloudiness.* |
| | | | | | | Miles per hour. | Direction. | Day. | | | | | |
| January..... | T. | 1.02 | 0 | 8,564 | NW. | 24 | NW. | 3 | 17 | 14 | 0 | 1 | 3.8 |
| February..... | 0.08 | .86 | 2 | 7,705 | NW. | 29 | NW. | 23 | 3 | 17 | 9 | 0 | 6.1 |
| March..... | .01 | .78 | 1 | 8,965 | NW. | 30 | NW. | 1 | 3 | 26 | 2 | 0 | 5.6 |
| April..... | 2.68 | 2.76 | 5 | 6,390 | NW. | 25 | N. | 5 | 8 | 16 | 6 | 6 | 5.1 |
| May..... | 10.71 | 8.98 | 14 | 4,999 | NW. | 23 | NW. | 2 | 0 | 15 | 16 | 14 | 7.7 |
| June..... | 5.80 | 8.15 | 13 | 4,118 | NW. | 34 | S. | 15 | 0 | 18 | 12 | 20 | 7.4 |
| July..... | 10.25 | 8.16 | 20 | 5,176 | NW. | 24 | SE. | 14 | 1 | 10 | 20 | 18 | 7.8 |
| August..... | 6.33 | 7.53 | 20 | 5,024 | NW. | 24 | N. | 18 | 1 | 14 | 16 | 18 | 7.3 |
| September..... | 8.38 | 7.46 | 20 | 4,451 | NW. | 31 | NE. | 23 | 0 | 14 | 16 | 20 | 7.6 |
| October..... | 17.89 | 10.92 | 23 | 4,538 | NW. | 23 | S. | 28 | 1 | 11 | 19 | 14 | 7.5 |
| November..... | 6.38 | 10.45 | 22 | 5,105 | NW. | 25 | NW. | 17 | 2 | 13 | 15 | 5 | 6.9 |
| December..... | 3.27 | 4.18 | 13 | 5,007 | NW. | 20 | NW. | 16 | 6 | 16 | 9 | 9 | 5.8 |
| Year..... | 71.78 | 71.25 | 153 | 70,042 | NW. | 34 | S. | * 15 | 42 | 184 | 140 | 125 | 6.6 |

¹ Elevation of barometer 92 feet above sea level.
² Average for 14 years' record.
³ Tenths of sky.

⁴ April.
⁵ February.
⁶ June.

November, 1912, inclusive, twenty or more rainy days occurred each month. At Culebra, from nineteen to twenty-four, and at Colon from twenty

to twenty-seven. These conditions favored rapid development of vegetation and kept in existence

TABLE No. 6.—Monthly meteorological data—Culebra, Canal Zone, year 1912.

| Month. | Atmospheric pressure (inches). | | Air temperature (degrees Fahrenheit). | | | | | | | | Mean wet thermometer. | Mean temperature dew point. | Mean relative humidity (per cent). |
|----------------|--------------------------------|------------|---------------------------------------|----------|------|---------------|----------|------|---------------|----------------------|-----------------------|-----------------------------|------------------------------------|
| | Station. ¹ | Sea level. | Monthly mean. | Maximum. | Day. | Mean maximum. | Minimum. | Day. | Mean minimum. | Maximum daily range. | | | |
| January..... | 29.438 | 29.851 | 79.0 | 90 | 8 | 87 | 68 | 27 | 70 | 21 | 71 | 70 | 85 |
| February..... | 29.460 | 29.874 | 79.2 | 91 | 10 | 88 | 65 | 2 | 71 | 24 | 72 | 70 | 84 |
| March..... | 29.442 | 29.854 | 80.4 | 92 | 7 | 89 | 68 | 12 | 72 | 23 | 72 | 70 | 79 |
| April..... | 29.464 | 29.874 | 81.4 | 96 | 17 | 91 | 67 | 2 | 72 | 27 | 73 | 70 | 79 |
| May..... | 29.430 | 29.840 | 81.2 | 96 | 6 | 89 | 70 | 20 | 74 | 22 | 75 | 74 | 87 |
| June..... | 29.436 | 29.848 | 80.2 | 91 | 21 | 88 | 70 | 16 | 73 | 20 | 75 | 74 | 92 |
| July..... | 29.420 | 29.832 | 79.8 | 91 | 12 | 80 | 70 | 17 | 73 | 18 | 74 | 74 | 92 |
| August..... | 29.423 | 29.836 | 79.5 | 92 | 8 | 87 | 69 | 12 | 72 | 19 | 74 | 73 | 92 |
| September..... | 29.422 | 29.834 | 78.7 | 90 | 1 | 86 | 67 | 24 | 72 | 21 | 74 | 73 | 93 |
| October..... | 29.430 | 29.844 | 78.6 | 90 | 5 | 86 | 68 | 29 | 72 | 17 | 73 | 73 | 93 |
| November..... | 29.428 | 29.842 | 78.0 | 88 | 22 | 84 | 69 | 17 | 72 | 17 | 73 | 72 | 93 |
| December..... | 29.414 | 29.828 | 78.8 | 88 | 1 | 86 | 67 | 18 | 72 | 19 | 73 | 72 | 91 |
| Year..... | 29.434 | 29.846 | 79.6 | 96 | 4.5 | 87.2 | 65 | 5.2 | 72.1 | 27 | 73.2 | 72.1 | 88.3 |

| Month. | Precipitation (inches). | | | Wind. | | | | | Number of days. | | | | Average cloudiness. ³ |
|----------------|-------------------------|----------------------|-------------|-------------------------|-----------------------|-------------------|------------|------|-----------------|--------------|---------|----------------|----------------------------------|
| | Monthly total. | Normal. ² | Rainy days. | Total movement (miles). | Prevailing direction. | Maximum velocity. | | | Clear. | Part cloudy. | Cloudy. | Thunderstorms. | |
| | | | | | | Miles per hour. | Direction. | Day. | | | | | |
| January..... | 0.05 | 1.75 | 2 | 7,697 | NW. | 28 | NW. | 31 | 17 | 14 | 0 | 0 | 3.5 |
| February..... | .33 | .56 | 4 | 7,864 | NW. | 30 | NW. | 24 | 9 | 20 | 0 | 0 | 4.3 |
| March..... | .02 | .68 | 1 | 8,893 | NW. | 35 | N. | 4 | 9 | 22 | 0 | 0 | 4.1 |
| April..... | 3.14 | 3.80 | 4 | 7,059 | NW. | 30 | N. | 25 | 6 | 21 | 3 | 2 | 4.9 |
| May..... | 8.15 | 11.16 | 15 | 5,538 | NW. | 27 | SW. | 8 | 0 | 11 | 20 | 15 | 7.4 |
| June..... | 7.57 | 8.86 | 21 | 3,715 | NW. | 25 | SE. | 15 | 0 | 9 | 21 | 21 | 7.8 |
| July..... | 10.12 | 9.52 | 22 | 4,962 | NW. | 36 | NE. | 30 | 0 | 13 | 18 | 14 | 7.7 |
| August..... | 12.88 | 10.58 | 19 | 4,592 | NW. | 33 | NE. | 12 | 2 | 12 | 17 | 23 | 7.3 |
| September..... | 14.12 | 11.23 | 20 | 3,975 | NW. | 32 | NE. | 23 | 1 | 10 | 19 | 22 | 7.5 |
| October..... | 10.15 | 11.54 | 25 | 3,505 | NW. | 21 | N. | 7 | 0 | 9 | 22 | 22 | 7.6 |
| November..... | 7.59 | 12.30 | 24 | 5,039 | NW. | 27 | NW. | 17 | 0 | 15 | 15 | 11 | 7.4 |
| December..... | 4.87 | 7.68 | 15 | 5,567 | NW. | 24 | N. | 9 | 6 | 20 | 5 | 7 | 5.2 |
| Year..... | 78.99 | 89.66 | 172 | 68,406 | NW. | 36 | NE. | 30 | 50 | 176 | 140 | 137 | 6.2 |

¹ Elevation of barometer 404 feet above sea level.
² Average for 22 years' record.
³ Tenths of sky.

⁴ May.
⁵ February.
⁶ July.

innumerable small collections of water which could not evaporate before being replenished. The continuity of the rainy periods, rather than the total

34 The Control of Mosquitoes

volume of rainfall, is the important factor affecting *Anopheles* propagation.

TABLE No. 7.—Monthly meteorological data—Colon, Republic of Panama, year 1912.

| Month. | Atmospheric pressure (inches). | | Air temperature (degrees Fahrenheit). | | | | | | | | | | |
|----------------|--------------------------------|------------|---------------------------------------|----------|------|---------------|----------|------|---------------|----------------------|-----------------------|-----------------------------|------------------------------------|
| | Station. ¹ | Sea level. | Monthly mean. | Maximum. | Day. | Mean maximum. | Minimum. | Day. | Mean minimum. | Maximum daily range. | Mean wet thermometer. | Mean temperature dew point. | Mean relative humidity (per cent). |
| January..... | 29.862 | 29.872 | 82.2 | 88 | 22 | 86 | 76 | 8 | 78 | 11 | 74 | 72 | 77 |
| February..... | 29.880 | 29.892 | 80.8 | 88 | 27 | 85 | 71 | 10 | 77 | 15 | 75 | 73 | 82 |
| March..... | 29.870 | 29.882 | 82.4 | 88 | 29 | 87 | 76 | 11 | 78 | 11 | 75 | 73 | 79 |
| April..... | 29.886 | 29.897 | 82.8 | 90 | 20 | 88 | 74 | 18 | 78 | 15 | 75 | 73 | 78 |
| May..... | 29.844 | 29.854 | 82.0 | 91 | 5 | 87 | 73 | 21 | 77 | 14 | 77 | 76 | 85 |
| June..... | 29.849 | 29.860 | 80.2 | 89 | 9 | 84 | 73 | 16 | 76 | 15 | 77 | 76 | 88 |
| July..... | 29.841 | 29.852 | 80.6 | 89 | 27 | 84 | 71 | 1 | 77 | 14 | 77 | 76 | 88 |
| August..... | 29.836 | 29.846 | 80.2 | 89 | 9 | 84 | 72 | 7 | 76 | 14 | 76 | 75 | 87 |
| September..... | 29.829 | 29.840 | 79.4 | 89 | 17 | 84 | 71 | 25 | 75 | 15 | 76 | 75 | 87 |
| October..... | 29.834 | 29.846 | 79.0 | 88 | 12 | 84 | 72 | 29 | 75 | 14 | 75 | 74 | 88 |
| November..... | 29.840 | 29.850 | 78.6 | 88 | 5 | 82 | 73 | 14 | 75 | 14 | 76 | 74 | 89 |
| December..... | 29.834 | 29.845 | 80.4 | 87 | 26 | 84 | 73 | 17 | 76 | 12 | 76 | 74 | 84 |
| Year..... | 29.850 | 29.861 | 80.7 | 91 | 45 | 84.9 | 71 | 10 | 76.5 | 15 | 75.8 | 74.2 | 84.3 |

| Month. | Precipitation (inches). | | | Wind. | | | | Number of days. | | | | | |
|----------------|-------------------------|----------------------|-------------|-------------------------|-----------------------|-----------------|------------|-----------------|--------|--------------|---------|----------------|----------------------------------|
| | Monthly total. | Normal. ² | Rainy days. | Total movement (miles). | Prevailing direction. | Miles per hour. | Direction. | Day. | Clear. | Part cloudy. | Cloudy. | Thunderstorms. | Average cloudiness. ³ |
| January..... | 0.28 | 3.96 | 9 | 10,772 | N. | 32 | NE. | 5 | 7 | 23 | 1 | 0 | 4.9 |
| February..... | 1.81 | 1.47 | 15 | 10,066 | N. | 32 | N. | 8 | 5 | 21 | 3 | 0 | 5.5 |
| March..... | 0.66 | 1.67 | 11 | 12,550 | N. | 33 | NE. | 5 | 13 | 16 | 2 | 0 | 4.4 |
| April..... | 0.75 | 4.08 | 6 | 10,620 | N. | 33 | NE. | 24 | 16 | 12 | 2 | 0 | 3.7 |
| May..... | 12.03 | 12.41 | 17 | 7,614 | N. | 26 | NE. | 18 | 2 | 17 | 12 | 12 | 6.6 |
| June..... | 15.90 | 13.35 | 24 | 5,165 | W. | 26 | NE. | 17 | 1 | 15 | 14 | 19 | 7.3 |
| July..... | 13.13 | 16.38 | 26 | 7,574 | N. | 25 | NE. | 28 | 3 | 12 | 16 | 8 | 7.1 |
| August..... | 9.87 | 15.01 | 20 | 6,892 | N. | 29 | W. | 19 | 1 | 18 | 12 | 21 | 6.8 |
| September..... | 12.23 | 12.53 | 22 | 5,473 | SE. | 37 | W. | 2 | 3 | 10 | 17 | 16 | 7.0 |
| October..... | 17.65 | 14.29 | 26 | 5,490 | SE. | 38 | SW. | 23 | 1 | 12 | 18 | 14 | 7.5 |
| November..... | 21.81 | 21.86 | 27 | 7,519 | W. | 34 | NW. | 17 | 0 | 10 | 20 | 10 | 8.4 |
| December..... | 11.47 | 12.31 | 21 | 8,992 | NE. | 29 | NE. | 13 | 9 | 17 | 5 | 1 | 5.3 |
| Year..... | 117.59 | 129.32 | 224 | 98,727 | N. | 38 | SW. | 23 | 61 | 183 | 122 | 101 | 6.2 |

¹ Elevation of barometer 10 feet above sea level.
² Average for 42 years' record.
³ Tenths of sky.

⁴ May.
⁵ February.
⁶ October.

The Isthmus, as may be seen by reference to the map of the Canal Zone, is well supplied with streams and natural watercourses. Some of them

are of great length. At Gatun many flow from the hills toward the settled area. During many rainy periods, when all the soil is well water-soaked, the hillside streams give least trouble, as the larvæ are washed out of them. Unfortunately

TABLE No. 8.—Comparative wind records—Ancon and Sosa, fiscal year 1912-13.

| Month. | Ancon. | | | | | Sosa. | | | | | Excess wind movement (per cent). ¹ |
|----------------|-------------------------------|--------------------|-------------------|------------|------|-------------------------------|--------------------|-------------------|------------|------|---|
| | Average hourly wind movement. | Per cent NW. wind. | Maximum velocity. | | | Average hourly wind movement. | Per cent NW. wind. | Maximum velocity. | | | |
| | | | Miles per hour. | Direction. | Day. | | | Miles per hour. | Direction. | Day. | |
| 1912. | | | | | | | | | | | |
| July..... | 7.0 | 70 | 24 | SE. | 14 | 10.5 | 90 | 44 | SE. | 14 | 50 |
| August..... | 6.8 | 55 | 24 | N. | 18 | 9.9 | 76 | 40 | NE. | 23 | 46 |
| September..... | 6.2 | 43 | 31 | NE. | 23 | 8.9 | 71 | 39 | SE. | 14 | 44 |
| October..... | 6.1 | 37 | 23 | S. | 28 | 7.6 | 59 | 28 | NW. | 22 | 25 |
| November..... | 7.1 | 47 | 25 | NW. | 17 | 9.7 | 66 | 36 | NW. | 17 | 37 |
| December..... | 6.7 | 58 | 20 | NW. | 16 | 9.3 | 88 | 27 | NW. | 16 | 48 |
| 1913. | | | | | | | | | | | |
| January..... | 7.3 | 64 | 21. | N. | 29 | 10.7 | 89 | 30 | NW. | 7 | 45 |
| February..... | 9.3 | 68 | 26 | N. | 10 | 13.3 | 94 | 36 | NW. | 17 | 44 |
| March..... | 10.6 | 77 | 26 | NW. | 23 | 15.6 | 96 | 36 | NW. | 23 | 47 |
| April..... | 9.7 | 69 | 24 | N. | 2 | 13.5 | 88 | 36 | NW. | 5 | 40 |
| May..... | 6.7 | 63 | 20 | N. | 1 | 9.4 | 79 | 34 | NW. | 1 | 45 |
| June..... | 5.5 | 43 | 32 | S. | 11 | 8.0 | 61 | 48 | S. | 11 | 49 |
| Year..... | 7.4 | 58 | 32 | S. | 11 | 10.6 | 80 | 48 | S. | 11 | 43 |

¹ Sosa records compared with Ancon.

² June.

NOTE.—Elevation of Ancon anemometer 69 feet above ground and approximately 160 feet above mean sea level. Sosa anemometer 25 feet above ground and approximately 220 feet above mean sea level.

these hillside streams are often transporters of larvæ and pupæ, and become an important source of mosquitoes when they reach a lower grade, or enter larger streams or rivers near a settlement.

During dry periods streams become prolific sources of mosquitoes; and even after the stream becomes dry many depressions still contain water in which larvæ rapidly develop. As the rainfall is heavy, there is a rapid run off, and erosion

36 The Control of Mosquitoes

and the formation of pot-holes frequently result, often making it difficult to keep a stream properly trained, and unless controlled, larvæ will be found at its edges where there is least current velocity. Where branch streams occur, debris, sand, etc., are deposited at their junction with the main stream,

TABLE No. 9.—*Monthly evaporation—Canal Zone, years 1912, 1913, and averages.*

[Value in inches.]

| Month. | Ancon. | | | Rio Grande. | | | Gatun. | | | Brazos Brook. | | |
|--------------|--------|-------|----------|-------------|-------|----------|--------|-------|----------|---------------|-------|----------|
| | 1912 | 1913 | Average. | 1912 | 1913 | Average. | 1912 | 1913 | Average. | 1912 | 1913 | Average. |
| January.... | 7.370 | 5.935 | 4.889 | 6.363 | 5.392 | 5.577 | 7.208 | 5.435 | 6.322 | 6.066 | 6.387 | 5.842 |
| February.. | 6.755 | 6.439 | 5.384 | 6.134 | 5.844 | 5.605 | 6.048 | 6.889 | 6.468 | 5.572 | 6.616 | 5.493 |
| March..... | 7.795 | 7.816 | 6.480 | 77.099 | 6.762 | 6.832 | 7.649 | 8.602 | 8.126 | 7.081 | 8.455 | 7.140 |
| April..... | 5.721 | 6.465 | 4.813 | 6.732 | 6.436 | 5.454 | 7.394 | 7.333 | 7.364 | 7.321 | 7.466 | 5.663 |
| May..... | 3.746 | 3.963 | 3.149 | 5.350 | 4.033 | 4.372 | 5.335 | 4.606 | 4.970 | 5.707 | 4.167 | 4.474 |
| June..... | 3.098 | 3.615 | 2.708 | 3.836 | 3.812 | 3.388 | 3.263 | 5.083 | 3.031 | 3.729 | 4.500 | 3.492 |
| July..... | 3.386 | | 3.018 | 3.908 | | 3.715 | 3.889 | | 4.224 | 4.425 | | 3.710 |
| August..... | 3.648 | | 3.021 | 3.983 | | 3.749 | 4.316 | | 4.362 | 4.611 | | 3.906 |
| September.. | 3.395 | | 3.120 | 3.335 | | 3.719 | 3.799 | | 4.191 | 4.487 | | 4.140 |
| October..... | 3.458 | | 3.314 | 3.763 | | 3.590 | 4.123 | | 3.866 | 3.970 | | 4.063 |
| November.. | 3.723 | | 2.956 | 3.275 | | 3.010 | 3.351 | | 3.016 | 3.100 | | 2.834 |
| December.. | 5.333 | | 4.025 | 4.723 | | 4.126 | 4.809 | | 5.092 | 4.860 | | 3.790 |
| Year..... | 57.428 | | 46.877 | 58.501 | | 53.137 | 61.184 | | 61.032 | 60.929 | | 54.547 |
| Daily mean | .157 | | .128 | .160 | | .146 | .167 | | .167 | .166 | | .149 |

NOTE.—Averages at Rio Grande and Brazos Brook are based on four years' record; Ancon five years' record; and Gatun two years' record.

Evaporation measurements are from floating pans 4 feet in diameter and 10 inches deep at Rio Grande, Gatun and Brazos Brook, and insulated tank 10 inches in diameter at Ancon.

For monthly evaporation during past years, see previous annual reports.

and afford collecting places for larvæ brought down-stream.

Various accumulations of vegetable matter, twigs, branches, etc., are found at the edges of rivers and make suitable hiding places, often inaccessible to the fish that prey upon mosquito larvæ. At some points, seepage outcrops occur on the stream banks and are constant sources of larvæ throughout the year. It was not at all

unusual for the water in a stream to disappear into the substrata during the dry season and reappear at a lower level. As the areas so affected vary from year to year, it was necessary to inspect the stream beds up to their sources. There are

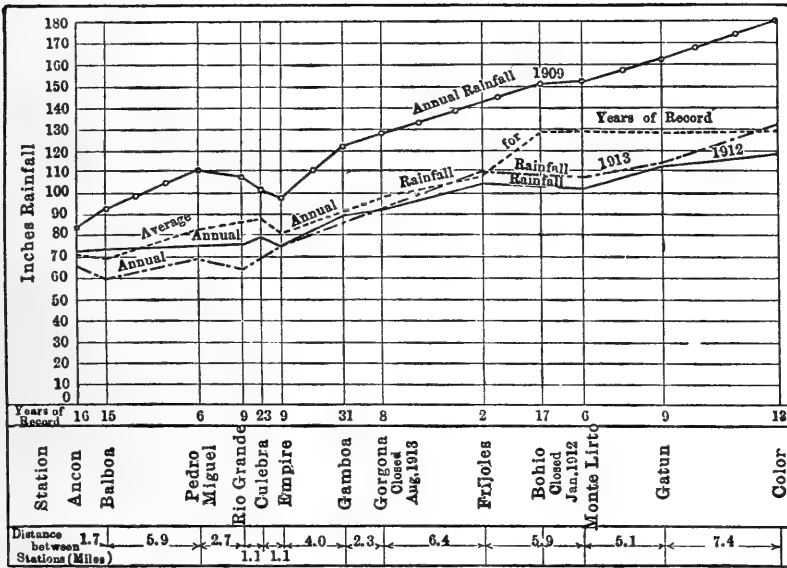

RAINFALL CHART

many marshy areas of large extent within fifteen miles from the Atlantic and six miles from the Pacific, in addition to the inland marshes near the occupied camps.

There is much marshy hillside caused by seepage outcrops. The impervious character of the soil enables small depressions to hold water for relatively long periods, especially where rank vegetation proves a barrier to evaporation by sun and

38 The Control of Mosquitoes

wind. The rainfall tables show the number of days a month on which rain fell. The depressions referred to above take time to dry out, and mud contains sufficient moisture to maintain life in larvæ of *Anopheles* and other mosquitoes. Admitting that the *Anopheles albimanus* readily travels half a mile or more, the numerous small depressions hidden by vegetation within a circle of half a mile radius are of importance, especially during very wet periods.

The climatic conditions of the Isthmus, except during the brief period of a few weeks toward the end of the dry season, are ideal for the propagation and multiplication of *Anopheles*. It is difficult to conceive of a locality where topographical changes have been made more frequently and rapidly. The cost of anti-malaria work depends largely upon topographical and climatic conditions.

Many miles of temporary track were frequently changed and often each tie removed left a water-holding depression. The excavation and transportation of material excavated was continuous for ten years. As the depth increased, more water seeped into the new channels or benches being cut by the steam shovels, and the former ditch sites were excavated.

As the bottom of the Canal was lower than the



A topographic change: near Empire



Constantly changing topography: near Miraflores

surrounding country most of the sub-surface water went toward it. The dumps where the excavated material was "wasted" often blocked natural drainage channels and ditches. Water collected constantly and proposed excavations and fills interfered with or prevented permanent drainage schemes. As the Canal neared completion, the bottom became too flat to drain economically and numerous small pools were left. Hundreds of acres of this territory had to be inspected and oiled each week. The hilltop of to-day becomes a depression a month later, and permanent drainage is often out of the question. The history of tropical malaria is generally alike east or west. It develops most rapidly when the soil is disturbed by large and extensive excavations and fills accompanied by the introduction of non-immune labor housed near the site of their work. Until now, no precautions had ever been taken in similar construction work in the tropics to prevent an increase in the number of places suitable for the development of malaria-conveying mosquitoes. Pools and stagnant water were brought into existence by fills that had settled. By the time the surface of a dump was in condition to hold water it was covered with rank vegetation, often more than

40 The Control of Mosquitoes

six or eight feet high, and the pools formed were hidden.

If inadequate provision is made for taking care of natural watercourses blocked by uninterested engineers, acres upon acres of new swamp lands may be formed, which are often ideal breeding grounds for mosquitoes. They contain few aquatic enemies of mosquito larvæ, plenty of food supply, and the tangle of vegetable growth protects the eggs and furnishes hiding-places for larvæ and pupæ. Such places are ideal for mosquitoes as soon as made, and outrival the freshly dug excavation, which is not frequently used by the *Anopheles* for ovipositing until conditions, such as protection for the young, food supply, and vegetable matter, tempt their presence.

It can be readily understood that if the area at the rear of the new dump or blocked portion of the drainage channel is flat or gently sloping toward the dam, a much larger area containing vegetation will become flooded. If the final water surface does not rise above the vegetation, the mosquitoes are better pleased. In many cases, nature lends a helping hand, and the vegetation under the water grows rapidly until it reaches and extends beyond the surface. Under these conditions, aquatic plants develop and fish find the larvæ with diffi-



Daily change of topography



culty and remove few of them. The water-fowl appear and may be the cause of the introduction of the kind of fish they come to catch. It is not at all improbable that fish-eggs stick to their legs and are thus transported from one place to another.

Extensive construction work, as a rule, is performed by contract. Each of the contractor's superintendents is responsible for one particular phase of the work and his entire time and attention are devoted to it. The foreman on the dump must unload his cars and return them within a minimum of time, the tracks must be moved with equal rapidity. If a culvert is to be elongated and no pipe is available, some makeshift is used and probably no attention is given to grade when the pipe is laid. The work is performed in record time, or possibly a record is broken, and the cost of the work for that day, week, or month is reduced an appreciable amount. Probably such saving and efficiency are properly rewarded, and the increased salary or bonus acts as a spur to even more rapid work. The makeshift culvert is soon covered up and does not show. If it collapses some time afterwards, the cause of the collapse is unknown. A lagoon is formed at the back of the dam. Unless the entire valley is filled, the artificial mosquito-producing area created is permanent, and when

42 The Control of Mosquitoes

the country becomes settled those living within a half-mile or so will be malarial, and people passing through the district will be affected similarly.

It is not an economy to expedite construction in such a manner. If a contract takes a long time to execute and the laborers become infected by *Anopheles*, created by the foreman's energetic though short-sighted action, what of the reduced energy or vital force of the workmen? Labor receives a daily wage and any decrease of output increases the cost of supervision. How does the loss of the laborers' efficiency compare with the saving made by neglecting proper care of the natural watercourse? If all, or a large part, of the force becomes infected what is the contractor's monetary loss?

History shows that important contracts have failed in the tropics, and in some cases the entire project has had to be abandoned. The anti-malaria campaign on the Isthmus showed exactly how and why these failures happen, and also provided opportunity for the study that may assist in determining the best and most economical means of overcoming future difficulties of similar or related character.



Blocked watercourse changed into an *Anopheles* breeding-place

CHAPTER IV

THE SPECIES OF ANOPHELES ON THE ISTHMUS

AT the beginning of the Isthmian anti-malaria campaign available knowledge on this subject was very limited, and confined largely to the experience gained in Cuba. It was not known how many different species of *Anopheles* existed, nor was it definitely known which of them were the important malaria carriers. The preliminary investigations demonstrated that they were not of domestic habits similar to the *Aedes calopus* and could not be considered house mosquitoes. Numerous containers near dwellings were carefully examined for *Anopheles* larvæ but none were discovered. The propagation areas appeared to be limited to seepage outcrops, pools, ponds, lagoons, ditches, streams, and the edges of rivers.

It was not thought that the daily flight range was extensive, nor was any information available on this subject with respect to the different species. It was easy to see that rank vegetation served as a

44 The Control of Mosquitoes

shelter or harboring place for *Anopheles* during the daytime, as well as for other mosquitoes. The climatic conditions were so different from those previously encountered that it was evident much investigation or pioneer work was required to obtain data pertaining to the general life history and habits of Isthmian *Anopheles*. We had no means of determining how seasonal changes would affect propagation, and the available data were unreliable. It was generally believed at that time that all mosquitoes traveled more or less with gentle air currents, but there was no positive knowledge of the habits of flight, and the length of flight of *Anopheles*, or of any other Isthmian mosquito. This was yet to be determined. It was not known if or how topography affected the distribution of species, whether *Anopheles* larvæ thriving in small collections of water held by plants were of economic importance, or whether certain species were confined by fixed geographical limits.

Dr. O. L. Howard assisted in the work in many ways and furnished valuable suggestions and advice.

Important collections of available species of Zone mosquitoes were made by Mr. A. Busck of the Smithsonian Institute and by Mr. A. H. Jennings, entomologist of the Isthmian Sanitary

Department. The determination of species found was made by Mr. F. Knab. Detailed studies of the relation to malaria of Isthmian *Anopheles* were made by Dr. S. T. Darling,¹ and portions of his published work are quoted.

In order to have sufficient adults for the experimental work, the sanitary inspectors along the line of the Canal sent pupæ and well developed larvæ to the laboratory daily. *Anopheles* larvæ and pupæ are delicate organisms and must not be subjected to rough treatment. They were transported in wide-mouthed jars, not too many in a jar, containing about an inch of water and shaded from the sun. If several inches of water are placed in the temporary container and subjected to the direct rays of the sun, or if the larvæ are too much overcrowded and subjected to constant shaking, many will die. By having shallow water but slight effort is needed for the larvæ to reach the surface. In collecting larvæ in the field white enameled saucers or dippers were found convenient, as the larvæ are easily visible against a white background.

In connection with the experimental work conducted at the laboratory, it became necessary to collect live adult *Anopheles* from houses at the

¹ See his *Studies in Relation to Malaria*.

46 The Control of Mosquitoes

various villages, ship them across the Isthmus, and have them arrive in their normal healthy condition. It was found absolutely essential to keep them shaded from sunlight, rain, and strong air currents. They appear to die rapidly if placed in a drying wind, which apparently causes evaporation that is fatal to them. The adults die if left overnight in mosquito-bars out in the open. If transported in cages few will die if the cage is completely covered with paper.

In the biting experiments made by Dr. Darling to determine which of the Isthmian *Anopheles* were malaria carriers, seventy per cent. of the *Anopheles albimanus* used became infected, about sixty per cent. of the *Anopheles tarsimaculata*, and thirteen per cent. of the *Anopheles pseudopunctipennis*. No *Anopheles malefactor* became infected although several bit the same person who infected the *Anopheles albimanus*. The conclusions drawn were: that *Anopheles albimanus* was the all-important transmitter of malaria fever in the Canal Zone at the time the experiments were made. *Anopheles tarsimaculata* was probably as susceptible to infection as *Anopheles albimanus*. The former, however, had a much more limited geographical distribution at that time, and appeared to be numerous only near Colon on the Atlantic coast.

Anopheles pseudopunctipennis appeared to be only slightly concerned in the transmission of malarial fever, if at all, as only about twelve per cent. of the specimens used became infected under the most favorable artificial conditions.

Anopheles malefactor did not become infected.

It also appeared in some cases that even the susceptible mosquitoes possessed immunity toward the malaria parasite and failed to become infected.

Unfortunately, *Anopheles albimanus* is the most abundant of the Isthmian *Anopheles*, and it makes stronger efforts to obtain entrance into inhabited buildings than any other species. It seems to prefer breeding places exposed well to the sun, and the green algæ in such exposed collections of water provides food for its larvæ. The larvæ are found in stagnant water but not when heavily charged with sewage; and at the edges of streams and rivers in places where there is practically no current. Although they are found at the surface in deep bodies of water when plenty of aquatic vegetation, debris, or other forms of protection are present, yet they are frequently found in puddles having a depth of only a fraction of an inch. Even after the water disappears the larvæ often continue to live for some time under a layer of algæ or in the soft mud. The adult will fly a long

48 The Control of Mosquitoes

distance to reach occupied houses; but is seldom found in vacant buildings.

The *Anopheles pseudopunctipennis* is found throughout the Isthmus, is not as strong a traveler as the other carriers, and is not so commonly found in houses as *Anopheles albimanus* or *Anopheles tarsimaculata*. Its season of abundance appears to be more limited. Running water that is relatively clear seems to appeal to this species. It does not bite as persistently as the others, and its relation to malaria on the Isthmus is not considered important.

Anopheles malefactor is apparently a non-carrier but a vigorous biter. At times large numbers of this species are found in houses. It recently became the most numerous species at the huts along the shore of Gatun Lake, when the water elevation reached eighty feet above sea level. Several months later it became relatively scarce.

The other species of *Anopheles* are not commonly found in buildings, and so far as malarial fever transmission is concerned are not of economic importance. Regarding the identification of larvæ, Dr. Darling has supplied the following data:

I have made no attempt to determine in detail all the anatomical characteristics of anopheline larvæ of this region; that has been done for some species by



Aquatic vegetation sheltering larvæ



Aquatic vegetation sheltering larvæ

Knab. The chief differentiating larval characters of the common anophelines of this region are these:

A. albimanus or white-footed group:

Palmate hairs on all abdominal segments and sometimes on postero-external angle of the thorax.

Antennæ without a tuft of hairs.

A. pseudopunctipennis group:

Palmate hairs on third, fourth, fifth, sixth, and seventh abdominal segments, but none on the first and second. On the latter two, however, there is a rudimentary stalked tuft replacing the palmate hairs.

Antennæ without a tuft of hairs.

A. malefactor or spotted-legged group:

No palmate hairs on first and second abdominal segments, but palmate hairs on all remaining segments.

Antennæ with a tuft of hairs.

These characters are very striking and sharply separate the malaria transmitting *A. albimanus* group from other varieties. With care it is frequently possible even in muddy water, from an examination of the indentations of the surface film caused by the palmate hairs, to at once determine the presence or absence of members of the *A. albimanus* group. In this group there is no break in the indented film, but in the two other groups there is a well-defined non-indented break in the film, due to the lack of palmate hairs on the first and second abdominal segments.

The size of the palmate hairs on the postero-lateral angle of the thorax, and the presence of these hairs on the thorax, first and second abdominal segments, is

subject to some variation. It would seem that the white-footed group is undergoing some variation with regard to the size and location of these hairs, and apparently they are becoming rudimentary on the thorax and first abdominal segment.

The larvæ are easily frightened and remain hidden under water during long intervals, and for that reason are sometimes difficult to detect. Experiments were made by immersing larvæ in cages in the body of water from which they were taken, and it was found that some of them remained alive under water for a period of two hours, even though the surface of the water was covered with oil after the cage was immersed. It is not widely known that *Anopheles* rest and remain upon dark clothing for relatively long periods although the wearer may be walking rapidly. It has been ascertained by observation that in this manner people convey them into houses that have been properly screened. Large numbers are carried long distances by trains at night. One observation was made in a case where a mosquito (genus unknown) resting on the shoulders of a man wearing a dark blue serge coat was carried from Colon to Porto Bello on board a steamer. The time of the trip was nearly three hours, and the distance about twenty miles. Observers were

afraid of disturbing the specimen by close approach but it was not an *Anopheles*.

There is no doubt at the present time that the *Anopheles albimanus* is responsible for practically all of the malaria transmission in the Canal Zone, except at Gatun and Colon, where *Anopheles tarsimaculata* sometimes exist in numbers large enough to be of equal economic importance. The decrease of malarial fever in Panama will be in proportion to the eradication of these two species.

It is now known that both species travel in enormous numbers over long distances (if other suitable propagation areas are not available) between their place of origin and the nearby settlements. On the Isthmus, in two instances where breeding was prolific, they have been known to travel from half a mile to a mile to reach houses. They do not seem able to remain long in a very strong light, and as a rule prefer darker places. No other Isthmian mosquitoes are so persistent in attempting to enter screened houses, and yet once inside they seem unable to find a way out, and collect on the screening soon after daylight, and again at dusk. When they find they cannot get out they return to the interior of the building, but make another effort to pass the screened openings at the same hours next day. They are seldom

found on the screens between 9 A.M. and dusk. When *Anopheles* in buildings are trying to find openings in the screens of windows or balconies they are not easily frightened and are readily captured. They are so persistent in seeking an opening that it is necessary to alarm them several times before they will leave the screening.

When such extensive topographical changes were made that it was temporarily impossible to control the increased influx of mosquitoes at a camp, the laborers of the oiling brigade destroyed mosquitoes found in barracks in the early mornings.

A description of Isthmian *Anopheles* as given in Darling's *Studies in Relation to Malaria* is quoted below:

The following is a list of anophelines of the Canal Zone:

- Anopheles argyritarsis*, R. D.
- Anopheles tarsimaculata*, Goeldi.
- Anopheles gorgasi*, D. K.
- Anopheles albimanus*, Wied.
- Anopheles cruzii*, D. K.
- Anopheles apicmacula*, D. K.
- Anopheles punctimacula*, D. K.
- Anopheles malefactor*, D. K.
- Anopheles eiseni*, Coquill.
- Anopheles franciscanus*, McCrack.
- Anopheles pseudopunctipennis*, Theob.



Swamp near Balboa, caused by building of dikes

The above eleven species of anophelines have been collected in the Canal Zone during the past eight years. They are not taken nor do they exist in their breeding places in anything like equal numbers. For example: Only one specimen of *A. gorgasi* has been found. Of the eleven species, the commonest ones are *A. albimanus*, *A. pseudopunctipennis*, and *A. malefactor*, but this again must be qualified by stating that the predominance of a species varies from season to season and from place to place. In certain villages, upon going through the barracks only *A. albimanus* will be found, while in other villages from five to ten per cent. of the mosquitoes will be *A. pseudopunctipennis*, and at Ancon during October, 1908, twenty-seven per cent. were *A. malefactor* and seventy-two per cent. *A. albimanus*. *A. tarsimaculata* appears to be distributed solely near the Atlantic. Mr. A. Busck, of the Bureau of Entomology, United States Department of Agriculture, who collected and made observations on Zone mosquitoes during 1907, gave it as his opinion that *A. pseudopunctipennis* was the commonest anopheline during the period of his stay.

The necessities of the Canal operations in excavating and filling change the topography of districts and localities so as sometimes to convert salt marshes into fresh-water ponds, or to make tracts of land containing few anophelines into a vast swamp in which they luxuriate. On the other hand, swamps and breeding places may be drained or filled in the work of excavation. These factors, among others, influence the number and variety of species in a locality.

The commoner anophelines of the Canal Zone may be divided into three groups:

- (A) The white hind-footed group, comprising: *A. argyritarsis*, *A. albimanus*, *A. tarsimaculata*.
- (B) The leg-uniformly-colored group, comprising: *A. pseudopunctipennis*, *A. franciscanus*.
- (C) The spotted-leg group, comprising: *A. malefactor*, *A. apicmacula*.

These groups present well-marked differences in the markings of adults, in the breeding habits and anatomical characters of the larvæ, and, as will be shown, they possess varying susceptibilities to malaria.

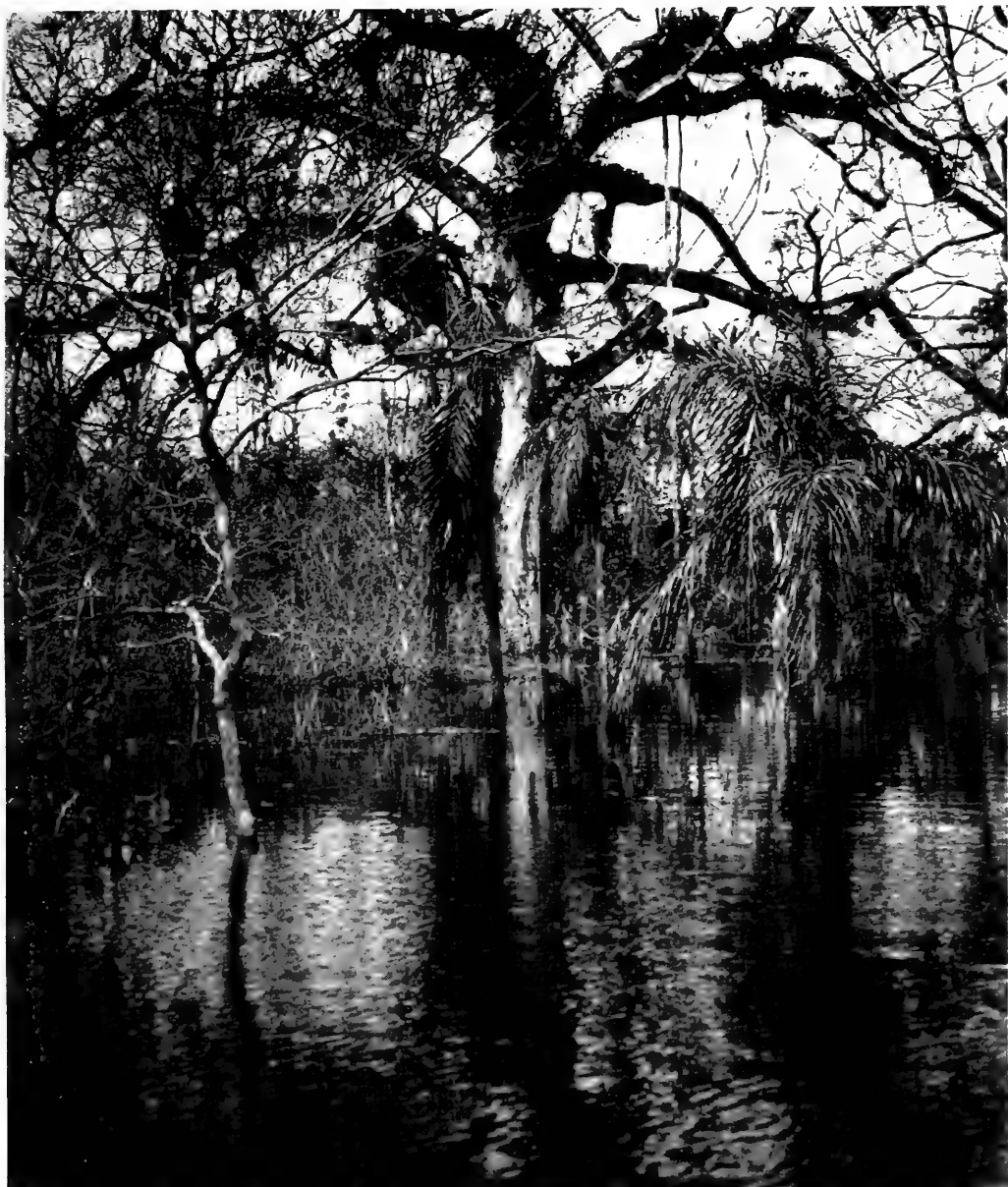

The rising waters of Gatun Lake

CHAPTER V

ANOPHELES PROPAGATION AREAS

WATER CONTAINERS

THE larvæ of *Aedes calopus* and *Anopheles* are seldom found in the same water. On the Isthmus the larvæ of the latter are seldom found in containers, while *Aedes calopus* are found only in containers near inhabited buildings. If containers are upset or their contents enter into a pond or ditch the larvæ of *Aedes calopus* will develop to maturity; again, if broad flat containers are so placed that vegetation grows in them, or if they are covered up in the grass and gather vegetable matter, dead leaves, twigs, etc., resembling natural breeding places, *Anopheles* will at times be found in them, but these conditions rarely occur and are not of practical importance. Isthmian *Anopheles* are not container breeders, and the sum total produced by water containers is very small. They are found occasionally in large wells or cisterns where

the water is near the ground surface, and into which dead grass, sticks, and leaves have fallen. The number of these collections of water is limited.

HOOF-PRINTS

The hoof-prints of cows and horses become important *Anopheles* producers. Riders often take horses over soft ground and in the wet season each hoof-print may become a source of larvæ. Cows seem to be particularly fond of walking in soft-bottomed ditches, and remaining at the edges of ponds. In this climate they are not stabled. Where the soil of the pasture is of a soft or clayey character, the foot-prints may be one to six inches or more in depth. These depressions often hold water throughout the wet season, and retain it from showers during the dry season. It is a difficult and expensive task to locate and fill, or treat, all hoof-marks holding water in a large flat field. The conditions are not improved if such a pasture is subjected to occasional flooding. It has been necessary in some instances to place fences around ponds and portions of pasture lands that become prolific sources of mosquitoes. In a few cases, where wet pasture lands were close to thickly settled suburbs, or villages, it became necessary to have the cattle removed elsewhere.



Cattle on low pasture lands: Panama

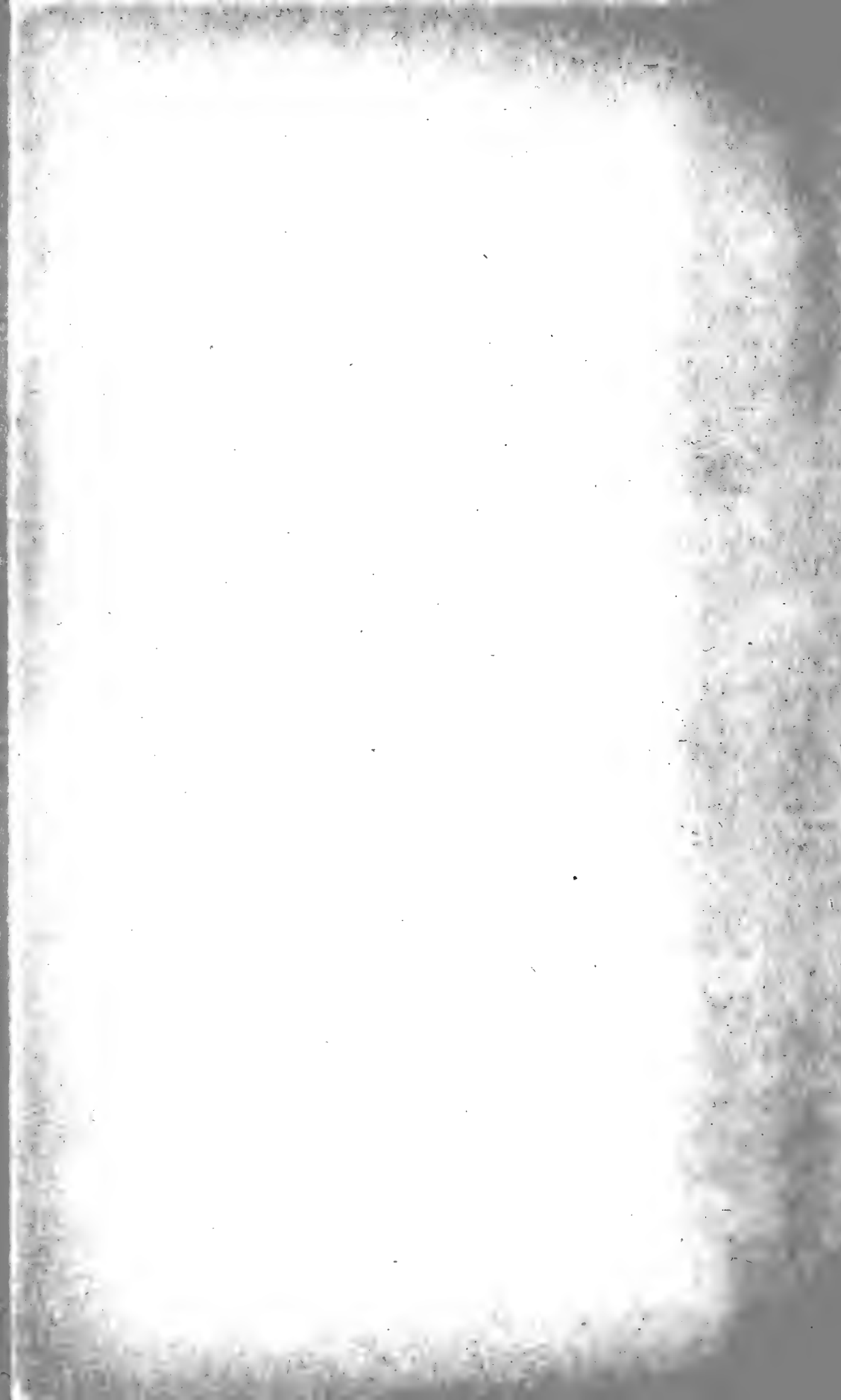

In the dry season pasturage is not good on dry lands, and the owners of animals are then inclined to turn them loose, or fasten them in low spots, and near ditches. An active animal can spoil a trained ditch in one night, and leave it in a condition to become the most prolific source of mosquitoes in the vicinity. This matter was found to be so important that legislation became necessary to keep ditches in proper shape. It is unlawful now for horses or cattle to be at large, or tied in places where their presence interferes with anti-*Anopheles* operations and becomes a sanitary nuisance. Even so, it is necessary to put up sign boards along ditches and in places where animals are not desired. When sign boards were first placed on soft ground to notify people not to tie animals in that vicinity, some poor ignorant natives who could not read thought the sign posts were excellent objects to which to tie their animals. Night policing is still essential to enforce the ordinance.

WHEEL TRACKS OF WAGONS

On bad roads, not frequently used, the rut marks produce *Anopheles* and *Culex*, but where travel is frequent there are no larvæ. Where wagons pass through pasture land in the wet

season and haul material over fields for construction purposes, areas of considerable extent are cut up and the drivers seldom use the same route twice; they find hauling easier over untrodden ground, and temporary roadways may thus be widened as much as a hundred feet. Near settlements the matter is of sufficient importance to make the filling of these new ruts necessary. It is more economical to fill in than to treat with oil weekly for an indefinite period.

EFFECT OF LONG RAINY PERIODS AND FLOODS

Floods occur during the rainy season and are generally preceded and followed by showers; and the rapid currents thus caused removed many if not most of the larvæ from the banks of rivers, streams, ditches, and the pools or depressions near them. Unfortunately the overflow reached depressions on adjacent lands and caused new temporary breeding places. When the flood was of short duration and was followed by dry weather and strong winds it was even advantageous. The latter condition rarely happened on the Isthmus.

Continuous rainy periods with daily showers for twelve days or more, whether accompanied by floods or not, are the cause of prolific mosquito production on flat lands. Practically all Canal



The effect of floods: Empire



Algae united with oil in mat-like masses: Empire

Zone land is covered with luxuriant vegetation which retards evaporation. On flat lands mosquito eggs were laid in shallow water pools or films of water and accumulated in the relatively low spots. These places were grass covered and before they dried sufficiently to kill off the developing larvæ, another shower fell. If the wet mud was collected and dissolved in water, mosquito larvæ in all stages of development were often found. In excessively long rainy periods it is not easy to locate, reach, and treat small places dispersed over large areas, but if they are neglected, enormous numbers of mosquitoes ensue. Evaporation and ground absorption may or may not dry ground sufficiently to prevent the development of the greater part of the mosquito crop. Just what will occur cannot be foreseen, nor can it be estimated in advance during which month of the rainy season such ideal mosquito conditions may prevail.

A variation of rainfall at villages three miles apart often resulted in a large influx of adults in one village and not in the other. At times the areas apparently needing attention were so extensive that the situation appeared hopeless, but experience gained in each locality by the inspector in charge was of great value. A new man requires

60 The Control of Mosquitoes

time to become thoroughly acquainted with the conditions peculiar to his district, that each day's work may produce the maximum of effective results. In time he becomes expert in omitting much that is but apparently necessary.

STREAMS

Large and small streams and natural water-courses, although dry for several months of the year, often become important propagation areas. Their relative importance or output of adults varies with the season. As a rule, during the wet season larvæ are found in quiet places along the banks where vegetation occurs or overhangs the banks or where debris collects. It seems to be an instinct of the *Anopheles* to lay her eggs where there will be a maximum of protection, or hiding places, and of food supply for her brood. Small detached bodies of water adjacent to the stream are favorable; and where the banks are muddy, the footprints of those looking for larvæ may become filled with water by seepage from the stream, and later contain larvæ. Where the water is quiet or shallow, green algæ develop rapidly and by retarding the current assist the *Anopheles*. These places offer favorable harboring places for larvæ.

Anopheles Propagation Areas 61

“Pot-holes,” or circular depressions, often form in the stream bed. The current may be swift only at the center and larvæ may be present at the edges where the debris collects. A sharp down-pour will often collect most of the debris, algæ, eggs, larvæ, and pupæ and carry them on downstream. They may, and often do, collect in quieter places in the larger stream or lagoon below. Where streams flow toward a settlement and empty into quieter waters near it, the adult mosquitoes in houses often increase suddenly, due to the new supply of pupæ and larvæ thus transported toward it.

It must not be assumed that algæ in ditches when treated with oil or larvacide will cease to exist. A week or less may start and complete a new growth. Often crude oil and algæ unite and form a mat that floats on the surface and in a few days a part or all will settle to the bottom of the stream; or may collect in irregular depressions along the bank. Such conditions offer hiding places for larvæ and make inspection both slower and more difficult. In shallow streams having coarse gravel or stones on the bottom and along the wetted perimeter, when debris, grass, or well-developed algæ are absent, larvæ hide under the small stones, and though none may be detected

at the water surface it is always well to remove sufficient stones to be sure that they are not hiding underneath. Frequently they remain hidden for long intervals. When the stone under which the larvæ are hiding is moved, they will rapidly travel to the next nearest stone that affords a suitable hiding-place.

As the dry season advances, the source of hill-side streams moves farther downhill, the upper part remaining dry. In case the stream bed is of irregular grade and contains deep depressions, as the bed becomes dry pools remain and become breeding places. Should the stream be of great length it is so easy to assume that its entire upper length is dry that such places are apt to be overlooked. Eventually the pools become dry, but generally produce one or more crops of mosquitoes before this happens. During the dry season, if a shower falls, the stream bed will probably be dry within a day or two, but it is never certain that these depressions have not collected water which they may retain for a week or more.

In the upper portion of the stream bed and higher than its dry season source, the sub-surface flow may outcrop at one or more points, and, due to the soil formation, grade, etc., flow along the stream for a short distance and again disappear



Railroad tie left in a tree by a subsiding flood in the Chagres Valley

Anopheles Propagation Areas 63

into the ground. The locations of the portions of the stream that act in this manner may change from year to year, and the observer is never sure that a dry stream is not producing mosquito larvæ until he has followed it throughout its entire length.

A minimum of mosquito larvæ will be present in a stream when it has been properly trained, that is, reduced to the minimum width of uniform cross section and freed from stones, grass, and debris that would interfere with the flow or velocity and furnish hiding-places for larvæ.

RIVERS

The larger rivers, where the banks are steep, are not sources of larvæ. As a rule they are less troublesome in the wet season than in the short dry one. If the banks are not much above the average water level, where flat lands are adjacent and floods occur, we have conditions similar to those in lagoons. At times of great floods, twigs, branches, and even whole trees are carried downstream and when they come to rest may act as collectors and hold grass, vines, and finely divided debris. Such places become sources of mosquitoes that larvæ-eating fish or top minnows often cannot catch. Obstructions of this nature at times change

64 The Control of Mosquitoes

the direction of the river bottom and leave new isolated pools as the water recedes. The high water causes much silt containing plant food to collect on the banks. This in turn produces luxuriant vegetation at the water's edge. Frequently the vegetation extends into the water and retards the current near the shore sufficiently to create suitable areas along shore in which *Anopheles* larvæ accumulate and remain. The Rio Grande on the Pacific slope of the Isthmus has been expensive to control because of these conditions, and it has been necessary to have workmen in boats continually on the river for mosquito control.

Rivers may or may not assist mosquito development in the wet season as above described. They are generally a most prolific source in the dry season. As the pools, ponds, streams, and marsh lands dry, the rivers become more sluggish and are the only available water sources remaining. Naturally the mosquitoes use them. Where the banks are kept clean, free from vegetation, debris, and stones in shallow water, the larvæ are seldom found. Mosquitoes instinctively avoid places that fish and other enemies reach easily, and lay their eggs in more favorable places. They select shallow pools with stony bottoms in the river



Oiling of breeding-places along a river bank



bed. Then vegetation grows around the edges in shallow water giving the desired protection. As the water is shallow, it becomes warmer and this assists the rapid development of algæ.

The larvæ can penetrate the algæ but small fish cannot. Algæ containing larvæ may be detached and floated downstream. Fish swim to and fro around it, and follow it, trying to seize the larvæ, but they seldom appear to succeed. Where the slope of the river bank is gradual, and the water at the edges shallow, with gravel or stone at the bottom, *Anopheles* larvæ are often found, providing other nearby and better protected breeding places do not exist. With the first heavy floods of the rainy season most of these river production areas are promptly eradicated.

SEEPAGE

Seepage water is water that flows underground along an impervious stratum and reaches the ground surface when that stratum becomes exposed at the surface, or approaches it. Or it may come through a stratum that is more or less porous and water bearing. The places where the water appears at the surface are called seepage outcrops. They are frequently found on benches, hillsides, and in small valleys. In areas where they

are present, sharp changes of grade, such as steep hillsides terminating on flat ground, or on more gentle slopes, should be carefully examined. The seepage on a hillside outcrop may approximately follow a contour line. The escaping water then flows downhill, and may again be absorbed by the soil, or continue to flow until it reaches a natural drainage course, or come to rest in a depression and form a pool or pond. On hillside seepage areas only a thin film of water is present, but small depressions in the ground give a depth of water sufficient for mosquito development.

Naturally the temperature of the water is relatively high and frequently seepage areas contain much algæ and few enemies of larvæ. Cattle complicate the situation by leaving deep hoof-prints. The outcropping water may be present throughout the year or only during short periods. Each outcrop is a law unto itself. Strange as it may seem, some places produce more water immediately after the rainy season, than during it. One such area was discovered at Balboa at the foot of a hill composed largely of trap rock.

In several localities seepage outcrops had been present only twice in ten years. Of course if such places are neglected it will be extremely

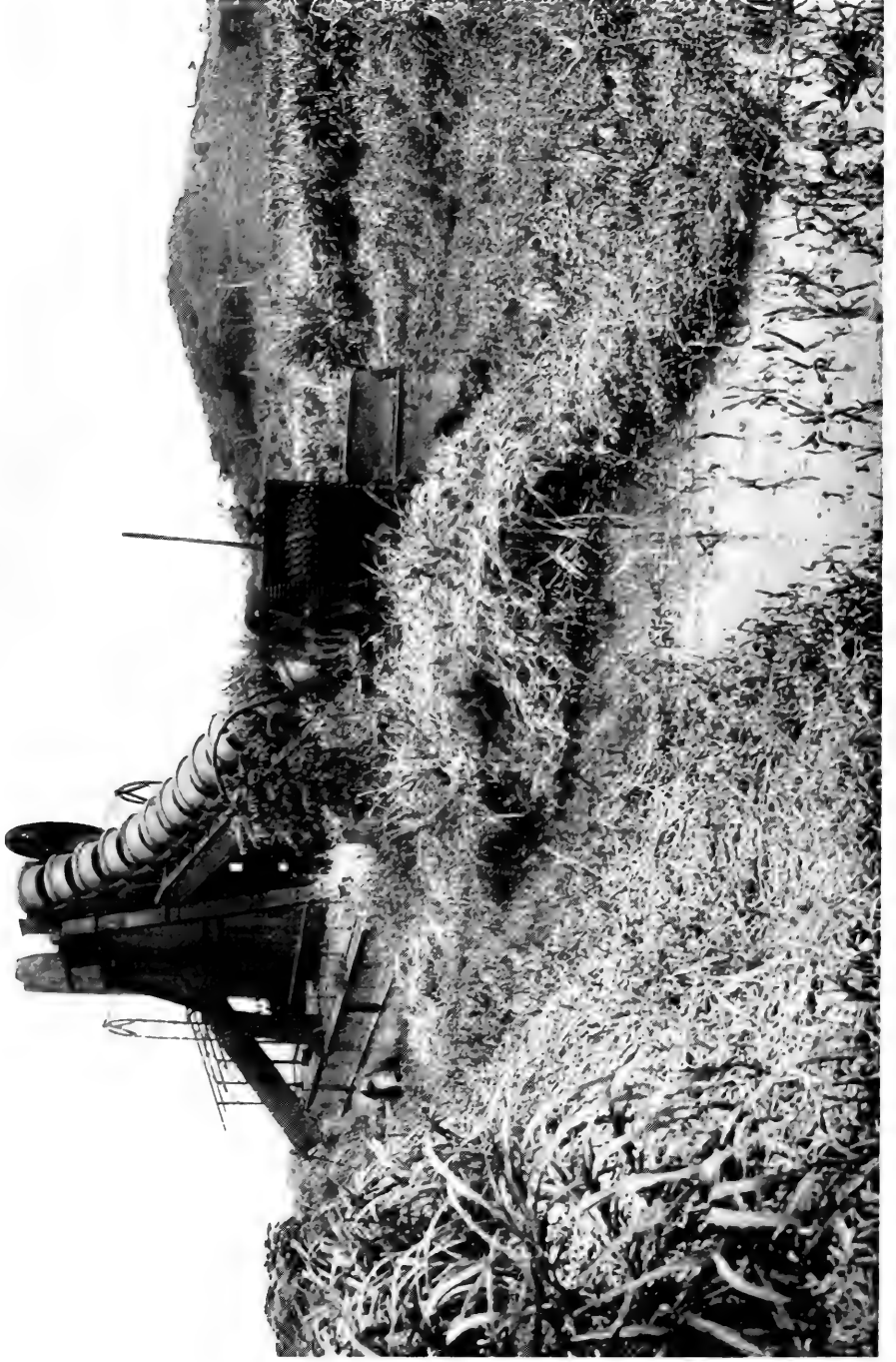

Vegetation protecting mosquito larvæ near an old French dredge

difficult to account for the presence of mosquitoes, and more distant production areas, winds, etc., may wrongly be held responsible for a temporary influx. Seepage may be found at most unexpected places during or after long rainy periods; it almost invariably produces mosquitoes, and in many cases may not be noticed until some adults have been produced. Nearly all seepage outcrops as well as areas flooded by seepage water were covered by the same class of vegetation that grew above the outcrop, and there was nothing to denote their presence. One cannot appreciate the number of mosquitoes produced by even small seepage outcrops without actually inspecting them.

LAGOONS, LAKES, PONDS, ETC.

Many parts of lagoons in the tropics are impassable and *trochas* or paths have to be cut through the heavy growth to penetrate some parts of them. Examination, or mosquito inspection, when the bottoms are soft deep mud is tedious but interesting, and the splashing of an occasional alligator removes any sense of monotony. It is surprising how many of these areas do not produce mosquitoes although conditions as to food, protection, etc., seem to be ideal. After examining many of this character the observer is apt to take it for

68 The Control of Mosquitoes

granted that *Anopheles* are absent. There are some prolific breeding areas whose importance cannot be determined without a thorough and painstaking examination.

Many lagoons, ponds, etc., have been seen where larvæ were not present near the shore line, but were very numerous in protected portions of deeper water. Water more than a foot deep, free from vegetation, debris, algæ, etc., is generally non-productive. It often happens that numerous larvæ are present only in particular parts of a large and apparently suitable breeding place, and it should be thoroughly investigated before any conclusions are drawn regarding its possibilities.

Again, some areas may produce a species of *Anopheles* larvæ only at certain times, and it is wrong to conclude that because results are negative to-day the conditions will not change sooner or later. Seasonal changes have an important bearing upon mosquito propagation.

In clear water such as reservoirs with clean edges and abrupt banks, more or less finely divided debris collects and is often removed from one side of the lake to the other by winds. Larvæ are frequently present in this mass, and apparently the small fish cannot reach them. Marked wave action prevents mosquito production. If the



A seepage outcrop, controlled by an intercepting tile ditch: Ancon

wind direction is uniform and continuous, larvæ will be absent on the shore affected by wave action. However, if there are small inlets along the shore line the wave action may not affect the larvæ in them, and they will need attention.

NON-PRODUCTIVE ANOPHELES PROPAGATION AREAS

In the Cuban anti-malaria campaign as well as on the Isthmus, there were so many apparently suitable places for mosquito development in which the larvæ were absent, that attempts were made to determine why *Anopheles* did not oviposit in them. The attempts were not successful. Larvæ were placed in many of these places and became fully developed. Mosquitoes were sometimes induced to lay their eggs in non-productive places by putting dead grass there. Investigation and research along this line is essential. Probably new facts will be discovered that may enable us to make existing production areas unattractive as breeding places and render them sterile. A dark brown or reddish substance resembling iron rust (name unknown), which is often accompanied by a small amount of natural oil, is found occasionally on the Isthmus at the edges of ditches or ponds in the form of a limited seepage outcrop and appears to be repulsive to *Anopheles*. Larvæ are never

found in that part of a body of water affected by it, although they are found in other parts of the same body of water to which this substance has not extended.

PROPAGATION AREAS CREATED BY MAN

It is surprising how many mosquitoes are unnecessarily brought into existence by people who are aware that the construction work they are doing will cause *Anopheles* to multiply. They do this even when it would cost no more to arrange for proper drainage. Borrow pits or excavations are made where they tap seepage water planes, and are sometimes left to collect water, in places where they cannot be drained.

River channels are blocked up near settlements, flooding hundreds of acres with shallow water. Culverts are situated in a way that causes ponds to be formed, and streams and ditches to fill with silt. They are often entirely closed up, and the water allowed to spread where it will. Such conditions have been created by engineers who knew the ensuing results, but were apparently in no way interested providing they did not suffer personally or financially.

The additional cost of controlling malaria in these localities has been enormous and made the



Vegetation removed from the edge of a pond at Bohio

cost of the anti-malaria campaign very much higher than it would have been had sufficient authority been given to the sanitary officials to prevent the unnecessary formation of hundreds of acres of artificially created mosquito-producing areas, with the corresponding attendant costs for their control, and for the care of sick laborers affected.

DITCHES

Even where anti-malaria work is being performed, parts of ditches or pools not kept in proper condition will harbor larvæ. Any obstruction or change of conditions that interferes with the flow of water in a ditch, and any condition that brings about the breaking of the continuity of the oil film may attract mosquitoes. Production is increased if the amount of water flowing in the ditch decreases.

Where the matted algæ breaks up and some portions of it sink, the direction of the small current in the ditch bed changes frequently, and increases the number of places and the extent of area where larvæ may be found. Conditions are aggravated if cattle have access to the ditch. If treatment is neglected or faulty inspection is made, the ditch becomes a menace and produces large numbers of mosquitoes daily. The flatter the

grade the more likely are such conditions to occur. The higher the temperature of the water the more favorable it becomes for rapid development. *Anopheles* larvæ have been taken in ditch water having a temperature of 102 degrees Fahrenheit.

CRAB HOLES AND PLANTS AS SOURCES OF ANOPHELES

Anopheles larvæ have been taken from crab holes both in depressions on flat land and on river banks which received larvæ from receding waters. It is known that *Anopheles* seldom if ever lay eggs in crab holes where water is below the ground surface. One species of mosquito, which does not bite man, habitually lays its eggs in sub-surface water in crab holes. It is not an *Anopheles*.

While larvæ of some species are found in water held by stems of plants, and in tree holes, the species that enter dwellings and are known to be malaria carriers seldom oviposit in such places. Propagation in water held by plants and trees was not considered of economic importance on the Isthmus.

CHANGE OF SPECIES CAUSED BY CHANGES OF SEASON OR OF LOCAL CONDITIONS AT BREEDING PLACES

It would be natural to expect a prolific source of *Anopheles albimanus*, or *Anopheles malefactor*, to



Result of blocking the Rio Cardenas. A change of species of *Anopheles* occurred here

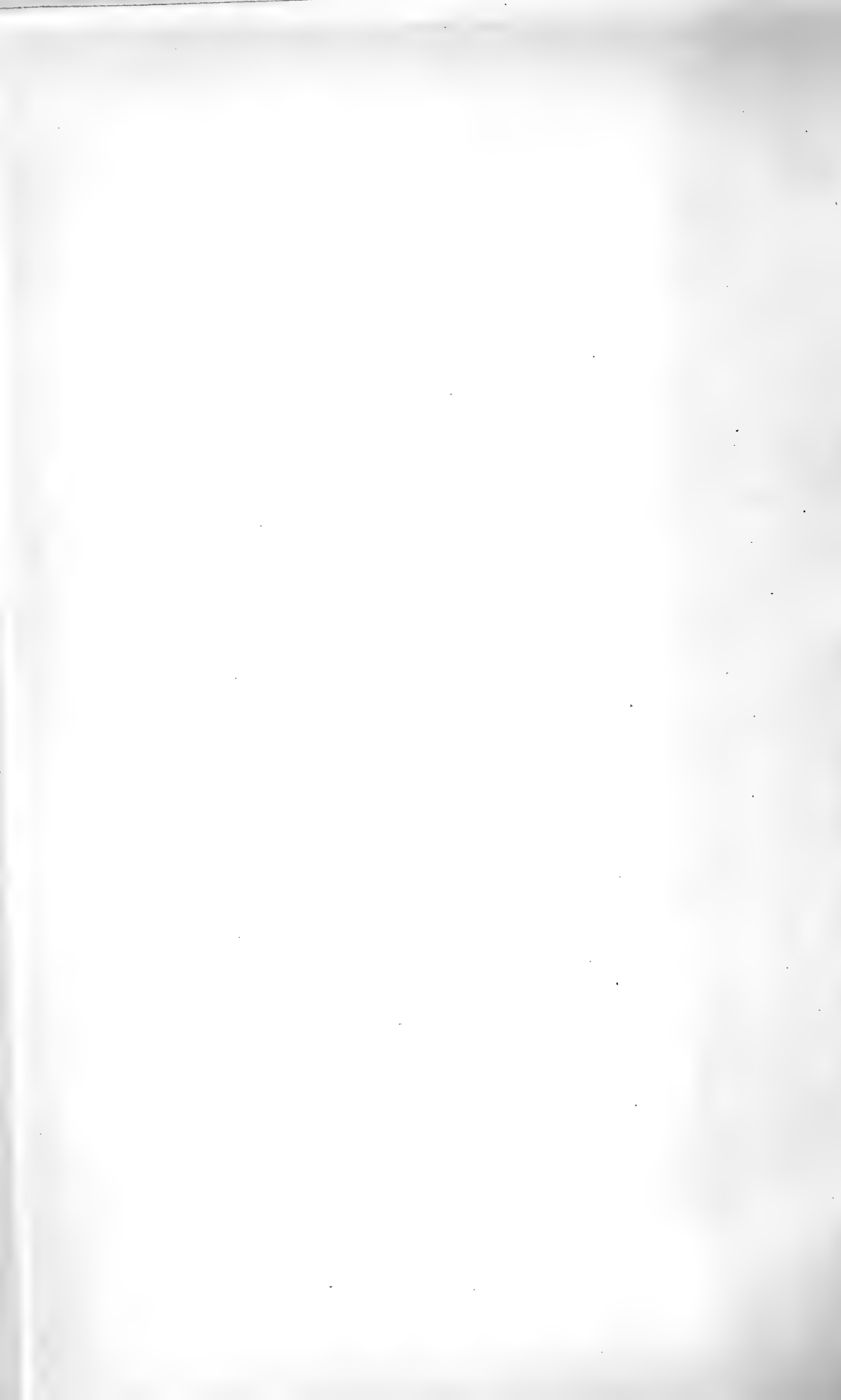

remain favorable to that species. We do not think this to be true. Certain changes take place the nature of which is not yet well understood. The fact remains that within a short period one species will sometimes disappear and be replaced soon afterwards by a large number of larvæ of another species. There are changes in the food-stuffs present, formation of algæ, plant growth, etc., and also other factors and changes that are at the present time unknown. Changes of species have been observed in relatively large bodies of water, such as lagoons, wide parts of rivers containing much aquatic growth, and in large ponds. In 1913 when the lake at Gatun was formed, conditions appeared to be quite favorable to the development of *Anopheles malefactor* and it became the prevailing species at Gamboa from November, 1913, to February, 1914, while previously the *Anopheles albimanus* was more common in houses. Since the last mentioned date the *Anopheles albimanus* has replaced it and later constituted about ninety per cent. of all *Anopheles* at Gamboa.

A similar change is taking place at Caño Camp, southwest of Gatun, on the shore of the lake. At that point the jungle is flooded with water and most of the trees and brush are now dead. Much of this growth was alive when the camp was first

established, about December 1, 1913. The monthly *Anopheles* catch at this camp was, December, 1913, 320; January, 1914, 1969; February, 1914, 2834. Recently the *Anopheles albimanus* is becoming the predominating species.

Strange to say until January, 1914, there has been no influx of *Anopheles* from the lake at Gatun and practically no breeding along the shore of the lake near that town, although within a mile conditions along the lake shore appear quite similar to those near Caño and Gamboa. Conditions may change and become favorable at a later date.

OCCURRENCE OF ANOPHELES IN BRACKISH WATERS

At Cristobal, Beach Island, in the Rio Grande valley, and at Gatun, *Anopheles* larvæ have been found in brackish and salt water. In the first three locations the propagation areas were affected directly by tide water. At Cristobal, in that part of the tidal flats covered by high tides and by excessive tides, larvæ were found to be numerous wherever clearings were made and leaves remained in the water. Clumps of plant stems afforded hiding-places to the larvæ of *Anopheles albimanus* and *Anopheles tarsimaculata*, even when small fish were present. Invariably larvæ were most

Anopheles Propagation Areas 75

numerous where the fallen leaves were most plentiful. These leaves were about eighteen inches wide and four feet or more in length. At Beach Island, the wet area, a mangrove swamp, was less brackish and well shaded by trees. It had a depth of from two to twelve inches and was filled with stumps of young trees relatively close together. No algæ and very little debris were present. The young larvæ were more numerous than those further developed. The older larvæ kept closer to the stumps. Probably the fish preferred them; this would account for the relative absence of large larvæ. In the swampy area in the Rio Grande valley the percentage of salt water varied with the tide and rainfall. *Anopheles albimanus* was the prevailing species. The deep water contained many mangrove trees and drift from upstream, while the more shallow water was well covered with grass, dead leaves, and plants that thrive in brackish water in the tropics. Larvæ could always be found in untreated portions of this area where there were sufficient hiding-places. The area was about a mile in length.

GATUN PROPAGATION AREA IN 1913

The largest influx of *Anopheles* that occurred in the Canal Zone during the canal construction

period came from a flat depression north of Gatun Dam. In making the channel near the entrance to the lower lock the material was excavated by dredges and passed through pipes onto the area referred to.¹ The canal channel at points where the dredges operated was several hundred feet wide and subject to the usual rise and fall of the tide. Previous to the introduction of salt water into this area it produced some *Culex* but not many *Anopheles*. It was covered with high grass and in many places with brush. The brush and trees began to die soon after the introduction of salt water. As the work of filling progressed, the increasing body of water spread over many acres and this sheet of water, about six inches deep, was hidden by tall grass. The water was deeper farther off shore. The area was more than a mile long and about half a mile wide. Flight observations indicated and fairly proved the direction the influx was taking before it was known by actual inspection of the swamp that this water was the source of thousands of mosquitoes that affected the settlement from half a mile to a mile distant. The water in the grass around the edges of the newly formed lagoon remained nearly fresh and no salt could be tasted along shore. In some

¹See Map of Gatun No. 36



Propagation area of Gatun mosquito influx where mosquito flight was discovered

places where tall grass grew salt was not perceptible to taste six hundred feet from the shore line. In wading out from the shore the water was tasted every few yards, and it was noted that young *Culex* and *Anopheles* larvæ appeared with the first indication of brackishness. In going farther from the shore as the water became more brackish the *Anopheles* larvæ found were more numerous and more mature. When the water became salty enough to be decidedly disagreeable to taste, *Anopheles* larvæ were most numerous. They were more numerous per unit of area than had been noted anywhere on the Isthmus during the previous nine years of anti-mosquito work. The absence of *Anopheles* and the scarcity of *Culex* larvæ in the wet zone not affected by salt water was unique. Tests made along shore at many points established the fact. The condition was so uniform that by wading slowly from shore to shore with eyes closed, and testing by taste alone, we were able to reach the infested zone and secure larvæ in collecting cups. The water surface contained large quantities of leaves that had fallen from the dying trees. Small larvæ-destroying fish were quite numerous, but larvæ of *Anopheles* and *Culex* were so plentiful in the salty water that it was impossible for the fish to make

any reduction. As time went on the density of larvæ increased. The observers studying the situation were bitten continuously by *Anopheles* of both species while standing in the water in full sunlight. The adult species present was chiefly *Anopheles tarsimaculata* although *Anopheles albimanus* and *Culex* were very plentiful. This was the only time or place on the Isthmus in which *Anopheles* were known to come out into the open and bite freely in full sunlight.

This production area continued in existence for several months and frequent analyses of the water for sea water content were made. In places where the larvæ were very numerous the water contained sixty per cent. or more of sea water and at times above eighty per cent.

Although the *Anopheles tarsimaculata* appears to thrive best in salty water, yet the larvæ have been found in fresh water in small quantities, and a few adults have occurred ten miles away from water affected by tide water.

METHODS OF DETERMINING THE PRESENCE OR ABSENCE OF ANOPHELES LARVÆ

In general we may expect to find larvæ in relatively quiet water where aquatic growth, vegetation, dead leaves, debris, and twigs have



Detail of *Anopheles* breeding ground where flight observations were made



Grass and plants almost covering the water surface and protecting mosquito larvæ

accumulated. If not disturbed or frightened they can be seen at rest on the water surface but often they dive or hide before the observer is sufficiently near to notice them. It is not usual to find them where such natural protection or source of food are absent. Grass and plants growing in the water are favorable, but dead vegetation appears to be more satisfactory. After a little practice an observer becomes expert in judging whether parts of a body of water contain larvæ. It is found convenient to use a small white enamel-ware saucer to dip for larvæ; this can be carried in a coat pocket when not needed. For continuous inspection work a white enamel-ware dipper is used to advantage. Where vegetation is present and larvæ are hiding in it, the saucer or dipper may be pushed up to the plant or grass stalks rapidly, and the larvæ drawn out of their hiding-places by suction as the water enters the saucer, or dipper. This method will obtain larvæ that are not detected in the water by the eye alone. When either of these methods fail, the larvæ may be detected by the application of larvacide. This substance spreads quickly under the water surface, and the larvæ rise rapidly in their efforts to escape. It is much used in the Canal Zone and many places can be rapidly examined by using a small quantity.

80 The Control of Mosquitoes

The commercial kresol preparations on the market have similar qualities but are more expensive than the product we use. If these aids are not at hand, fairly good results may be obtained in water of less than a foot deep by thoroughly stirring up the mud below the water. This generally makes the larvæ come to the surface in a short time. In shallow water where a large number of places must be examined in a short time, inspection is made by walking in the water and stirring with the foot. If grass or debris is present it must be pushed or held back to leave a clear area for observation. Where the water has almost disappeared from depressions, or only soft mud remains, samples may be washed in clear water to determine the presence of larvæ. The observer should walk along the beds of streams, or the edges of ditches or ponds, and examine all places that appear favorable, including floating debris on the surface of deep water. In ponds and lagoons in which tall grass grows examination should be made by boat, or if none is available the inspector must wade out until he knows the condition of all places that may harbor larvæ. It must always be remembered that the productive portions of a relatively large area may be limited to certain small ones, either in fresh or brackish water marshes.

Anopheles Propagation Areas 81

Seasonal changes must be also borne in mind. The unexpected happens very frequently in this class of work.

Only a few of the negro laborers wore hip boots for work in deep water. In the wet season the sanitary inspectors dressed in khaki, heavy leather shoes, and stiff pig-skin leggins. When heavy showers fell unexpectedly it was impossible to keep dry, and when bodies of water had to be examined they waded into them, and let the hot sun dry their clothing as it could. It was fortunate that the inspectors' enthusiasm lasted longer than their clothing! They found being drenched to the skin several times a day less fatiguing than wearing surveyor's boots for work in lagoons having soft mud bottoms. Boots would have been too heavy for the amount of walking and work of a day in such a hot and humid climate. The leggins were essential for protection from thorns, spines, and the red bugs that make life a misery to some.

It is often stated that sewage and polluted waters are favorable to the development of *Culex*, and that *Anopheles* are not found in it. This assertion did not hold true under the conditions in Cuba and Panama. The farther from the sewer outlet, the less will be the amount of organic substance carried by the water, and a

82 The Control of Mosquitoes

point is reached where the quality of the water becomes satisfactory to *Anopheles*.

In cases where sewers have broken on grass-covered hillsides mosquito larvæ have been found numerous within one to two hundred feet of the point of discharge.

CHAPTER VI

HARBORING PLACES AND FOOD OF ANOPHELES

IN uninhabited regions this species feeds on the blood of birds and animals, juices of fruits and of plants, and probably on the pollen of certain plants. Some observers think that blood is the normal food of female *Anopheles* and that other food is taken only when blood cannot be obtained. *Anopheles* apparently try to obtain more of it than other mosquitoes. We have observed that they do not bite in full sunlight. Constant observations on the Isthmus for a period of eight years, 1904 to 1912, failed to establish a single case. During these years, when numerous, they bit freely in the shade of woods. In 1912, at the breeding area of Gatun, direct sunlight on brightest days did not prevent six or eight *Anopheles* biting the face at one time. The species were *Anopheles tarsimaculata* and *Anopheles albimanus*. They attacked us while up to the knees in water as well as on shore. It is interesting to note that

84 The Control of Mosquitoes

both species were to some extent afraid of the light of a lantern at night in that particular location. If the lantern were behind the neck the face was bitten, and on bringing the light around toward the face, they immediately ceased operations on it and collected on the back of the neck, and continued biting vigorously. The same was true of the biting of the hands. The hand farthest from the light was the one bitten. They invariably left the lighted side of the hand, if it were slowly moved to about eighteen inches from the lantern. The same rule held true with regard to their settling on the observers' clothing, which continually occurred. This apparent fear of artificial lights had been noted in previous years at Corozal, three miles from the Pacific Ocean, but in that locality *Anopheles tarsimaculata* were then absent and *Anopheles albimanus* was the prevailing species.

When bright acetylene lights with reflectors (automobile lamps) were used at Corozal, an observer standing in the direct rays and holding his bare arms in them ten feet away from the lamp was never bitten. Yet when an obstruction was placed in the column of light and one inch of finger put behind the obstruction, in its shadow, several *Anopheles albimanus* settled on that finger in less

than one minute. Four observers were present when these tests were carried out. One of the men was known to be more attractive to mosquitoes than the others, but when, having started with his arms literally covered with *Anopheles*, he reached the zone of a certain intensity of light not one remained. They fled with a rapidity similar to the movement of people or animals whose eyes had been suddenly hurt. In all cases the light was sufficiently distant to cause no increase in temperature. It is difficult to account for the instance of biting in full sunlight at Gatun (near the breeding place only) as compared with all other cases of absolute repulsion caused by artificial light. Of course it is possible that the *Anopheles* at Gatun bit us while in the sunlight because otherwise they could never have obtained any blood. Their natural instincts are difficult to determine. In general, they are most ravenous at dusk and soon after daylight. When numerous they bite freely in shady places near the production area and at places distant from it where they rest during the daytime. Many were noted less than a foot above the ground on the leeward side of trees near the breeding area. On one tree forty-three were counted.

In a similar manner they are found on wire

86 The Control of Mosquitoes

screens on the leeward side of houses in large numbers while absent from screens on the windward side. At Gatun, when the mosquito influx was at its maximum, they were found at rest in brush and under dead grass on the wind-swept hillside, in large numbers under houses, and in any place that afforded protection from sun and wind. This condition existed for several months during the dry season. No natural flight in the sunlight has yet been observed. While, no suitable hiding places except vacant houses were without mosquitoes in the daytime, yet beyond the settled area none were found. They only rested in places between the brackish body of water and the village limits; and when grass in which they were resting was disturbed in the full sunlight they flew about ten feet to the next nearest shaded place.

Large numbers were collected under houses where the breeze was sufficiently strong to make the lighting of a match difficult. These inhabited houses were on posts from two to ten feet above ground. The dry weather ground-cracks under the houses were several inches deep and the mosquitoes collected in them, but when small bunches of grass or dry hay were placed under the houses they hid in these in preference to the cracks. None rested on the floor beams under the houses,

**Influence of Prevailing Wind Direction
and its relation to Anopheles entering houses.**

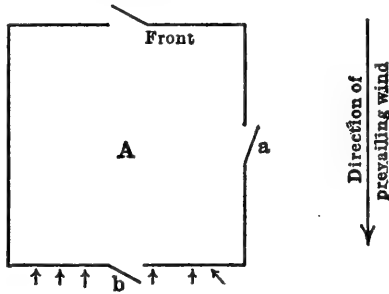

**A.-At time of wind Anopheles collect at rear of house.
(leeward side).**

Door (b) is the danger point.

Door (a) may be held open by wind.

Arrows denote resting or collecting places of Anopheles.

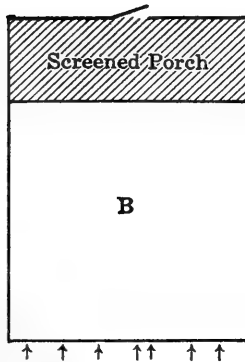

B.- Screened porch advantageously located.

Diagrams showing best locations for screen doors

**Influence of Prevailing Wind Direction
and its relation to Anopheles entering houses.**

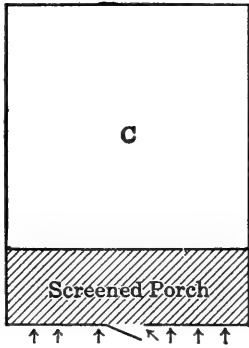

C- Anopheles collect on screen and enter if door is left open long enough.

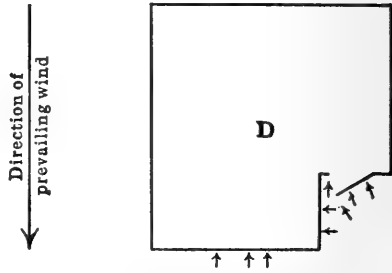

A Door in a re-entrant angle facilitates entrance of mosquitoes. They enter when the door is opened.

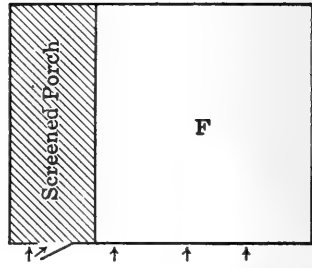
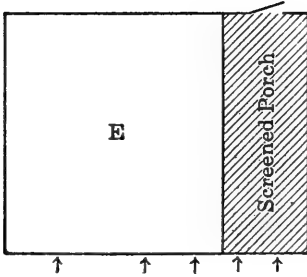

The door of screened porch (E.) is better located than that at (F).
↑↑↑ Anopheles

Diagrams showing best locations for screen doors

where there was enough light to read by with comfort.

In order to determine to what extent the mosquitoes rested in the shade under houses, mosquito bars were hung up to clear the ground by a few inches. A laborer was placed under each net. The mosquitoes did not hesitate to leave their daytime resting places and soon reached the nets, where they were collected. Account was kept of the number taken between six-thirty A.M. and five P.M. During a period of twenty-two days it was observed that thirty-three per cent. of their total number entered the nets between six-thirty and eight A.M. The total catch by this method under five houses in the same period was 14,322 adult *Anopheles*, mostly *Anopheles tarsimaculata*. These came from ground-cracks under the house and from the small quantity of dead grass that had blown there. In another five-day test, with a man under a mosquito bar beneath each of the five houses, 4389 female and 132 male *Anopheles tarsimaculata* were captured inside the nets. All these mosquitoes had been resting on the ground or in the ground-cracks under the houses. By poking the cracks with a stick they were disturbed, but flew away only a few feet to another hiding-place; none went out into the open where the sun was

shining. Although so many were under the houses none came out to bite anyone standing in the sun.

The Gatun salt-water swamp was the source of these mosquitoes.¹ The houses affected were numbers 3, 184, 185, 195, and 220, located near the railroad depot.² There are many other houses at Gatun, some less and some equally distant from the propagation area. Under most of them no mosquitoes were present in the daytime.

Although it is customary for mosquitoes to bite soon after sunset, cases have been known where observers remaining in one place from six P.M. were not bitten until eleven P.M., when *Anopheles albimanus* became suddenly numerous and fed freely. When the jungle surrounding houses was cleared, for several days mosquitoes entered them in much larger numbers than before the clearing was made. It is said that a fairly brisk wind prevents the flight and biting of mosquitoes, but on the Atlantic slope where the trade winds blow nearly all the year round, they often bite at dusk whether the wind blows or not. In infested settlements mosquitoes are seldom found in vacant houses.

When houses are imperfectly screened *Anopheles* are more apt to find defects than other mos-

¹ See map p. 101.

² See map p. 101.



Anopheles collected in the ground cracks under the houses in the foreground on the wind-swept hill. The breeding area was near the distant dredge. The houses and dredge are marked on the map of Catun

quitoes, but they have difficulty in finding their way out of buildings. In the daytime, they are more commonly found in the bedrooms than in any other part of the house.

Some people are more attractive to *Anopheles* than others. One of the sanitary inspectors was known to possess this quality, and the arms of three men were placed around his bare arm, so that any *Anopheles* desiring to bite him had to find their way to him through an inch wide opening between the bared arms of two other men. Several *Anopheles albimanus* did this. Some time later the same person and two observers trying to locate the principal source of *Anopheles* causing the influx at Cristobal were not bitten once from dusk to nine o'clock. A brown horse nearby was examined and found to be well covered with *Anopheles albimanus*. The observers sat down near the animal, but failed to attract a single mosquito in thirty minutes. They then began to catch the *Anopheles* that were biting the horse, using chloroform tubes: the mosquitoes attacking the horse arrived more quickly than they could be captured and kept the party busy. The catching was continued for an hour, and during that period none of the men were bitten. They had lamps and noticed that no mosquitoes settled on

their clothing, although they frequently examined the parts which were not exposed to the direct rays of light.

Mosquitoes not only enter trains to bite people, but remain in passenger cars that are in motion for long periods during the night time; they usually leave the car soon after daylight. Some are accidentally trapped in train closets and freight cars and are then transported long distances.

The importance of *Anopheles* settling on people's clothing, and being transported long distances and into screened houses has not received the attention it deserves. Cases have frequently been noted in which they remained on a man's coat during a stiff wind while he walked a hundred yards; and even longer transportation by this means, or on the backs of animals, is quite possible.

While flight observations were being made at Gatun, a chicken coop was examined at eight o'clock on two consecutive nights. The observers were bitten by *Anopheles* while watching the chickens, but failed to note any mosquitoes trying to bite the fowls. The *Culex* resting in large numbers on the chicken roost were not gorged and did not bite the fowls, but their position gave them shelter from the breeze. Those outside this shelter bit us freely.

In one instance three mosquito bars were placed in the woods for one night with a man under one bar, a dog under the second, and a coop containing fowls under the third. The net with the man collected 274 *Anopheles* and fifteen *Culex*, the dog's net had five *Anopheles* and nine *Culex*, and the fowls' net contained twelve *Anopheles* and six *Culex*.

CHAPTER VII

FLIGHT AND ATTRACTION OF MOSQUITOES

THE various species of mosquitoes have not the same habits. The differences of time of biting, of selection of propagation areas, quality of water in which larvæ are found, etc., are well known. Every night at certain periods of the year, hundreds of *Culices* are found dead in the globes of electric arc lights. *Anopheles* on the contrary are practically never found in the globes and will not fly close to a bright light. Apparently only a few species of one genus of mosquito are attracted by light sufficiently to be destroyed by the flame, while the Isthmian *Anopheles* and possibly others find a strong light repulsive. It is possible that some *Anopheles* associate lights with man.

The general direction of the wind at Panama is from north to south and it blows from south to north on but few days in the year. Many years of careful observation on the Pacific slope of the Isthmus gave fairly conclusive evidence of a marked

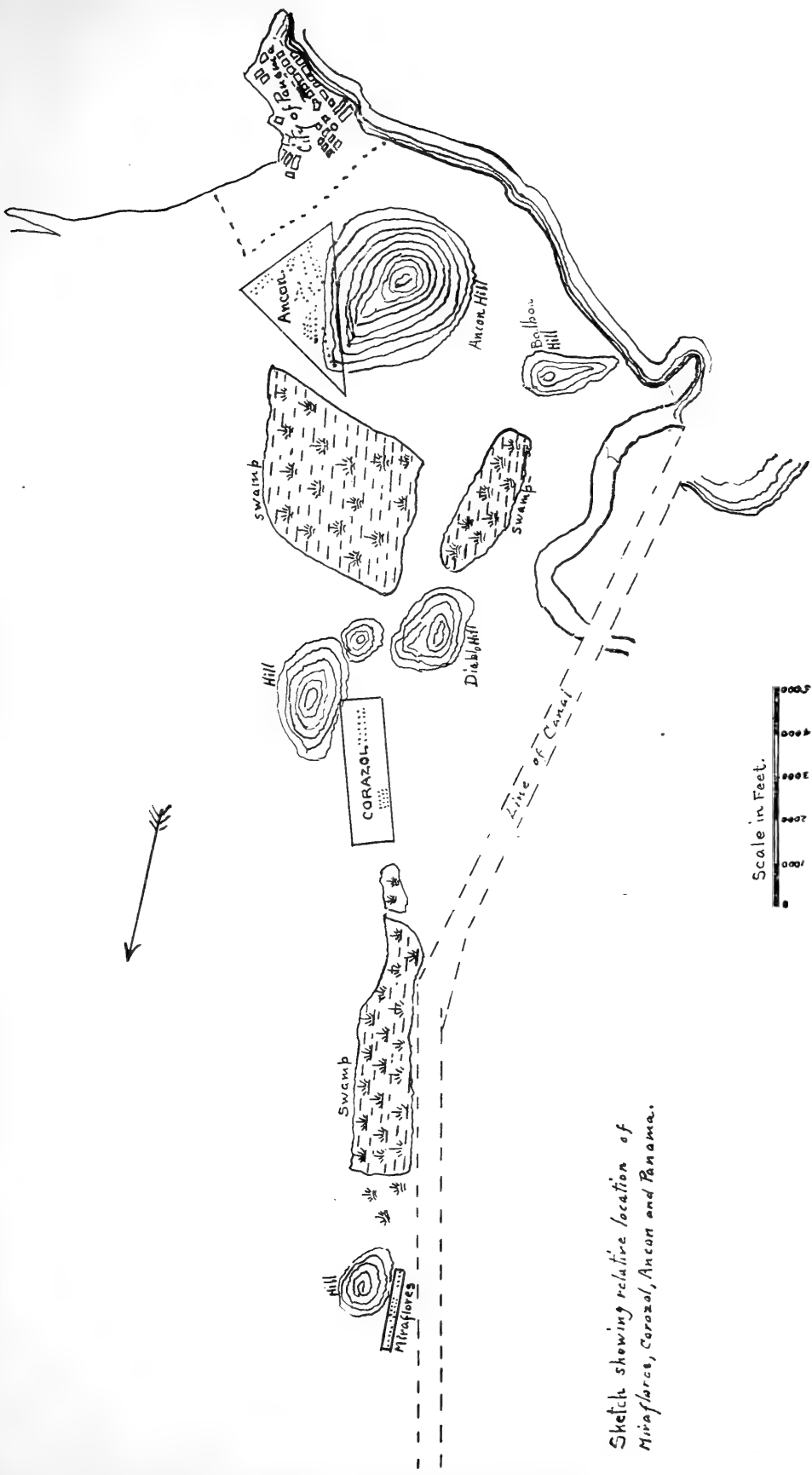

Sketch showing relative location of Miraflores, Corozal, Ancon and Panama.

The relative positions of Panama, Ancon, Corozal, and Miraflores



flight of *Anopheles* in a northerly direction, or against the wind, and this was reported by Le Prince at the International Congress of Hygiene, 1912.

Anopheles propagation areas occur near Ancon and the city of Panama, and the wind blows from those places toward the houses: if the flight of *Anopheles* was assisted by gentle winds the houses should contain many.¹ As a matter of fact, there are few at Ancon as compared with other settlements, and the production area there has been under observation for nine years.

Panama touches the Pacific Ocean. Beginning at the base of the hill on which Ancon, its suburb, is located, a swampy area extends for about two miles northwards, and the village of Corozal is three miles north of Panama. Three miles north of Corozal is the village of Miraflores, and a prolific *Anopheles*-breeding area lies between the two villages, extending over the larger part of the intervening distance. The southern end of this area is nearer Corozal than any part of the Ancon-Corozal swamp.

In 1911, work was concentrated on the southern portion of the Corozal-Miraflores swamp, in order to reduce the *Anopheles* arriving at Corozal. The

¹ See map opposite p. 95.

96 The Control of Mosquitoes

work on the windward side was ineffective, and the influx of *Anopheles albimanus* increased. Work in this swamp was then stopped and the force concentrated in a larvæ-infested portion of the Ancon-Corozal swamp about a mile south of Corozal. Since the latter area has been controlled no large influx of *Anopheles* has taken place at Corozal, except during short periods when the wind changed and blew from south to north.

The large swamp between Corozal and Miraflores was difficult to control in a satisfactory manner. It was neglected for a certain time to ascertain if, when producing *Anopheles* at its maximum capacity, many of them would reach Corozal, traveling with the wind. Apparently this did not happen, as the number of adults at Corozal did not increase while the other area a mile to the south of Corozal was kept under proper control.

Soon after the Corozal-Miraflores area was purposely neglected the catch at the laborers' barracks at Miraflores increased and the influx continued. The maximum catch in a single trap on one night was more than a thousand. This trap was attached to an 8" x 24" opening in the screening and the total area of small openings in the trap screen through which mosquitoes passed



Mosquito trap attached to a window screen



Mosquito trap (seen from inside the house)

Flight and Attraction of Mosquitoes 97

was less than eight square inches. During this high influx at Miraflores the low catch at Corozal continued. The most prolific part of the intervening production area was much nearer to Corozal than it was to Miraflores.

Is it the usual custom for this *Anopheles* to fly against light breezes? Is it possible that they are attracted by scent? Or when the number of *Anopheles* being produced in a limited area amounts to millions, do the habits of flight to obtain blood then change? These questions are exceedingly difficult to answer, but as they are of the utmost importance in successful and economical control of *Anopheles* they should be investigated.

The increase or decrease of electric lights in buildings apparently does not make much difference in the number of *Anopheles* entering. In several instances, by increasing the amount of light in a small experimental house at Corozal, the number of *Culex* (species not determined) increased even when vacant. When the building was empty or without lights, only an occasional *Anopheles* entered, but when one or two men were sleeping in the building *Anopheles* crowded through small openings and bit them whether the building was lighted or not.

Where buildings are well screened and *Anopheles*

outside are numerous, they will try to force their way through incredibly small cracks or defects in the screen. Many cases have been noted where they have become tightly wedged in their efforts to pass through openings that were too small, and then were unable to free themselves. While this experimental work was being done it was found that although the breeding of *Anopheles pseudo-punctipennis* and *Anopheles malefactor* was taking place much nearer to the buildings at Corozal than *Anopheles albimanus*, mosquitoes of the former species were not found at Corozal camp. It is evident, from the long-distance flights described above, that in some instances it was essential to locate and control the principal source or sources of *Anopheles*, which although more distant than other propagation areas located relatively near, may be, and in the two instances above mentioned actually were, the source of malaria-carrying *Anopheles* that reached the houses.

Gatun, about seven miles south of Colon, is one of the largest settlements in the Canal Zone. Above five thousand canal employees live there. Between January and March, 1913, more mosquitoes were found there than had been found in any settlement since work began on the canal. The weekly catch of the *Anopheles* that gained

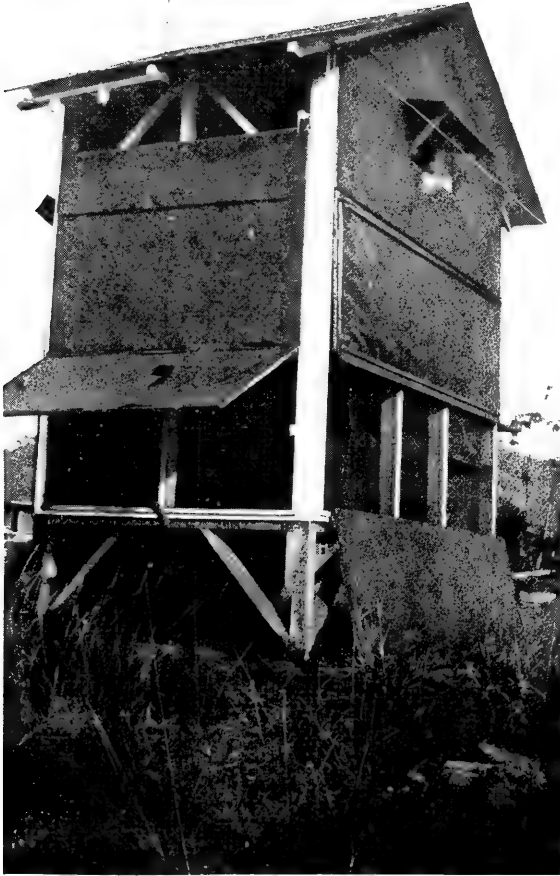

Experiment Station, Corozal, where studies were made of mosquito attraction by light

Flight and Attraction of Mosquitoes 99

access to the interior of dwellings varied from 7000 to 22,000. It was necessary for office men to burn smudges and wear leggins. The seats of cane-seated chairs were covered with paper, and many devices invented to make life more pleasant. During the worst part of the period of influx anyone out of doors at dusk was bitten many times per minute.

It was evident that some new source of *Anopheles* had been brought into existence. Wherever anti-malaria work had been done before, all known production areas were thoroughly examined, but gave no clue to the new situation, as they were in normal condition. The area under inspection for propagation places was extended. Mosquitoes were present in the daytime in all places sheltered from the sun and wind, except at the east of the settlement. To the south, was the shore of Gatun Lake along which much plant growth, debris, and floating islands collected. Certain aquatic plants were growing in solid masses from the shore line out into the water, and filled the spaces between the floating islands that had collected near the shore. Vines were growing on the debris, and the floating mass was more or less continuous along the shore. All of this new possible production area was carefully examined and very few larvæ were found.

100 The Control of Mosquitoes

The daily inspection was supplemented by night observations; the shore and the lake just off shore being observed. No mosquitoes were present on the lake at night and people in small boats close to the lake shore not far from the settlement were not bitten. It was evident after making many observations that the lake was not the source. Careful examination of all the territory to the north of the settlement failed to show any breeding places of sufficient extent or importance to account for the influx. The area to the west was examined last, because of the extensive cleared area west of the settlement which was known to be free from possible breeding places.¹

To the west of the old French canal there was some flat land into which the sea water and mud from the American canal was being pumped. This place had never before produced mosquitoes that affected Gatun, and was so located that to reach the settlement the adults would have to fly from half a mile to a mile straight across or at right angles to the stiff breezes which prevail at Gatun in the dry season, over ground containing very little protection from wind by high grass or bushes. Flight of this length under such conditions was not thought to be possible. Between the wet area

¹ See map.

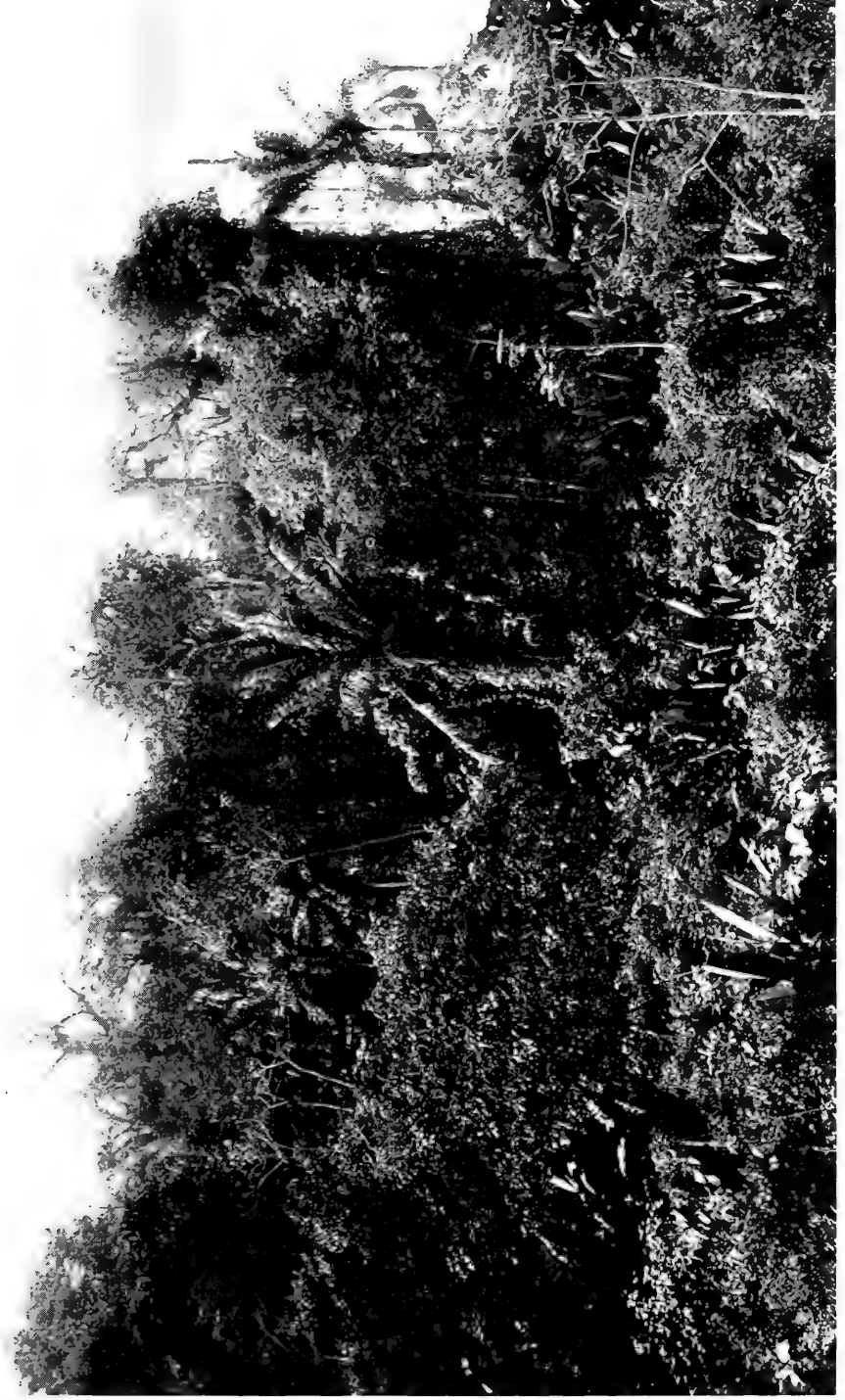

The shore of Gatun Lake



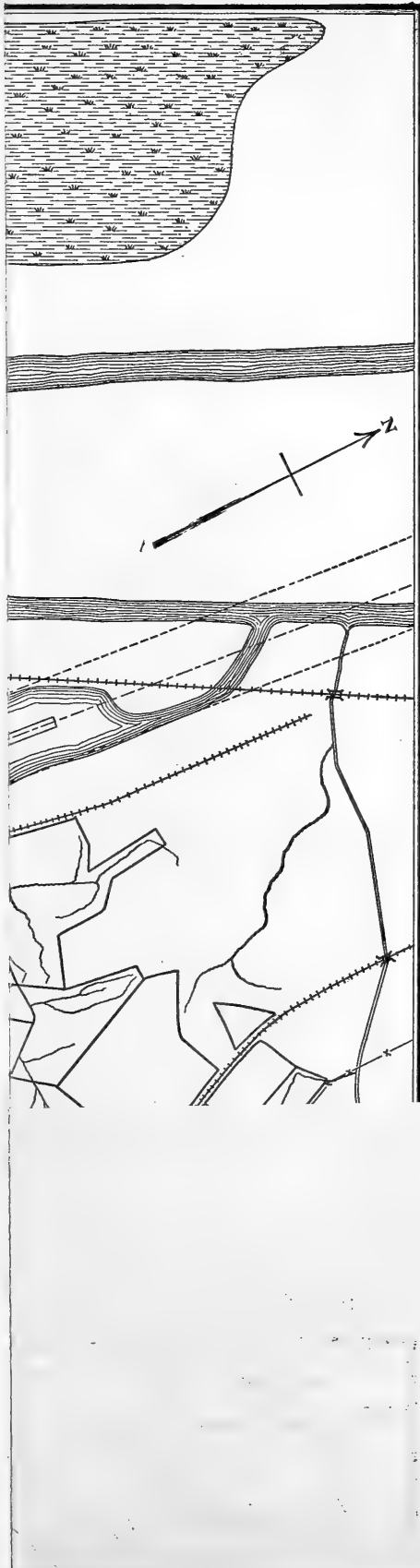



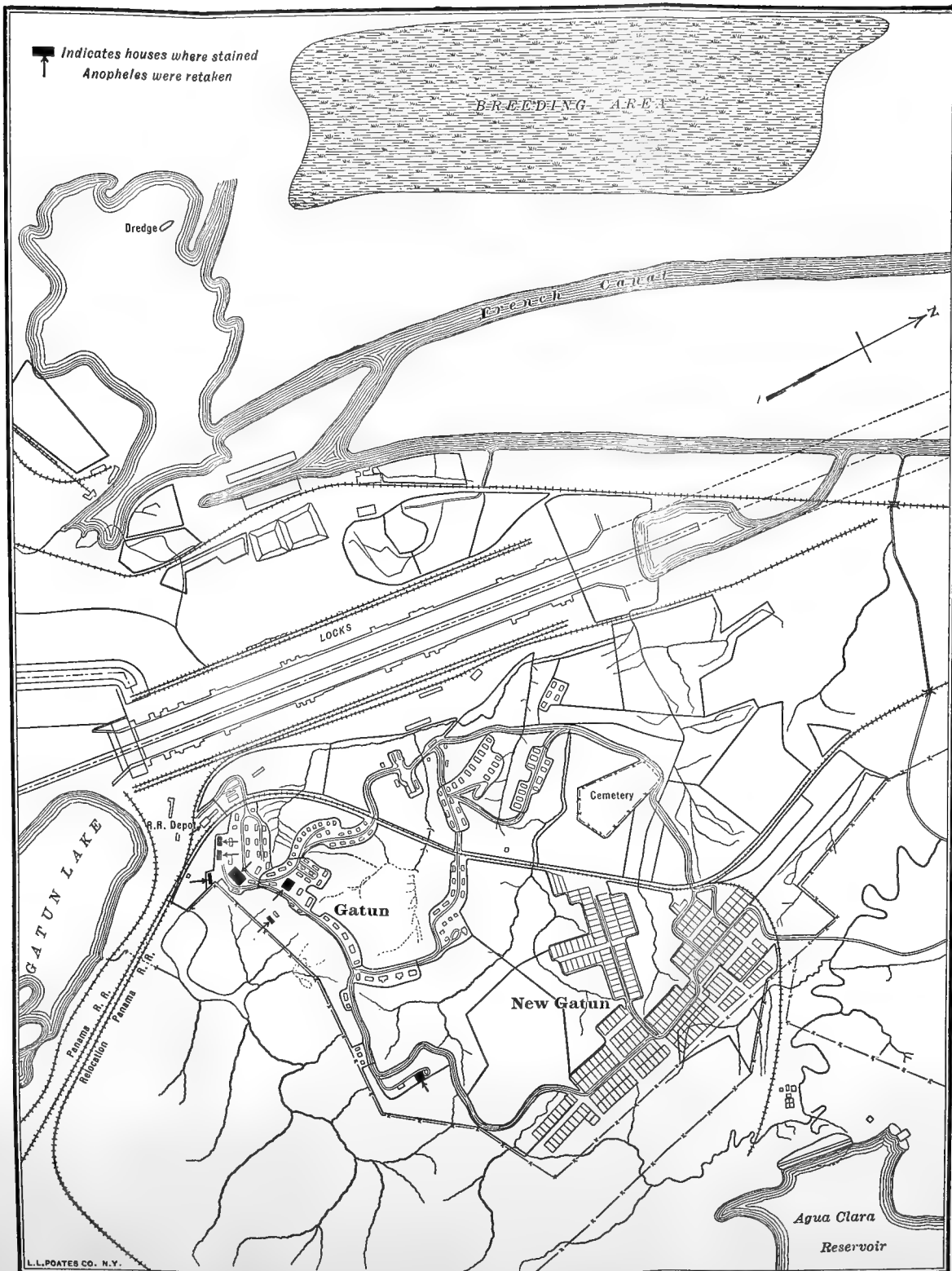

Map of Gatun: Showing *Anopheles* propagation area and houses where stained specimens were recaptured



The right side of the page is mostly blank, with some very faint, illegible text or markings that are likely bleed-through from the reverse side of the paper.

Flight and Attraction of Mosquitoes 101

formed by dredging operations and the French canal, and parallel to the latter, was a strip of woodland and heavy brush having a width of from one to two hundred yards. In this thicket mosquitoes were more numerous than at any other place in the Gatun district or on any area examined in trying to locate the source of the influx. The larvæ in the water and the mosquitoes near were numerous enough to account for the influx at Gatun; but was this the source? That was the important question to determine.

Several volunteer investigators visited the thicket at night and retreated in a very short time. After slowly rowing up and down the French canal at night it was determined that very few *Anopheles* were crossing that body of water. The party was seldom bitten until the boat was fastened to the bank, when it was bitten unmercifully. The same results were noted on successive nights and doubts arose as to whether this newly created area had any connection with the *Anopheles* at the houses about a mile distant. The surrounding country was again examined but with negative results. It was assumed that the enormous number of mosquitoes produced every twenty-four hours at the brackish water production area must of necessity spread out or travel a long distance to

find blood sufficient to satisfy them. It appeared within the limits of possibility that they might fly high at night during the lulls in the wind, and not be noted by people in boats on the French canal. The assumption was also made that the period of long flight might be of limited duration. Other factors bearing on the problem and all previous information obtained relating to Isthmian mosquitoes were given due consideration. We continued the investigation, beginning by making several careful observations on the French canal lasting more than twenty-four hours each before reaching any partial conclusions.

On January 20, 1913, at 4.30 P.M., two observers were posted on the opposite bank of the French canal from the propagation area, and, facing the latter, watched carefully for any indication of flights. They were prepared for a twenty-four hour watch, although extra night work had robbed them of much sleep in the past week. For two hours nothing happened. At 6.20 P.M. birds appeared in the air, apparently catching insects. They were at an elevation of thirty feet or more above the water surface. A little later it was noted that these birds fed at a lower elevation. At 6.30 interest deepened. The birds kept on feeding and then flew rapidly back and forth at six



Floating islands blown toward Gatun



Masses of aquatic plants and floating islands in Gatun Lake

Flight and Attraction of Mosquitoes 103

feet or less from the water surface. It was then that Le Prince, looking over the side of a flat bottomed boat toward the clear sky line, discovered the first appearance of the flight of *Anopheles* accompanied by *Culex*. The flight was from west to east and quite marked. He then selected a place on the opposite bank of the canal from the propagation area and faced it. As it became darker, the quantity of flying *Anopheles* increased, and, by bending low and looking past a dark object at the clear sky line, hundreds of *Anopheles* could be seen passing by in one definite direction. They not only traveled in a fixed direction but many appeared to hurry about it. After dark the flight was reduced to practically nothing. During the period of flight, the observers were bitten continuously. Soon after the flight ceased one could remain on the east bank (in the path of the recent flight) and be attacked only once or twice in an hour's time. All night long on the west bank, near the propagation area, and between it and the French canal, hundreds of mosquitoes surrounded and bit an observer. There was no secondary flight period, although observers remained to note if this occurred.

During subsequent evenings, the flight was recorded; it started about the same time each day.

On the second evening, directly after the birds arrived and began feeding, several were shot and examined. It was found that they were catching the *Anopheles*, some of which were found in their throats. These birds are called "night-jars"; they were feeding between thirty and forty feet above the canal and had not fed at a lower elevation.

After the flight direction near the canal was ascertained points of observation were selected between it and the settlement, and the direction of flight was noted to be relatively constant. When the winds came in short strong puffs, the *Anopheles* headed directly into it, but "skidded" sideways and were able to fly for short intervals at right angles to the direction they were facing. Some remained on the wing in a fixed location and as soon as they succeeded in controlling themselves, and conditions were right, dashed off eastward, at right angles to the direction of the wind. This forward flight of *Anopheles tarsimaculata* and *Anopheles albimanus* was so decidedly marked that after its discovery by the senior author it was easily noted by many, including those who at first scarcely believed it could be true. No one in the entire area so thickly infested noticed the flight direction until instructed how to observe it.

It was thought that with thousands of mos-

Flight and Attraction of Mosquitoes 105

quitoes traveling from the swamp to the settlement each night, an appreciable number might fly beyond the settlement.

Large numbers passed occupied houses and appeared at more distant ones; but apparently none passed the houses most distant from the breeding area. We remained in the shade in the day and thrashed the bush for a hundred yards beyond the settlement and stayed there at night without securing any specimens. Yet during this period they were present in practically all occupied houses, and particularly numerous in screened houses where the doors were frequently used, as at the hotel, Y. M. C. A. building, bachelors' and laborers' barracks, etc.¹

The results of the numerous observations showed that the *Anopheles* knew where they desired to go; that they traveled in a direct route at practically right angles to a strong breeze, and that large numbers went forward between 6.30 and 7.00 P.M. daily. It was not ascertained whether any of them made more than one forward trip to the feeding ground. It may be that several trips were taken, but had none returned the thousands passing out daily were sufficient to continue the influx at the settlement.

¹ See map opposite p. 101.

106 The Control of Mosquitoes

As it was definitely proved that the forward long-distance flight was of limited duration and occurred just at dusk, it was assumed that there should be a visible return flight at or before dawn. The first morning this was carefully waited for from midnight to 6 A.M. but did not occur, and the observers noticed very few mosquitoes, although thousands had passed them on the forward flight. It was thought that there must be a return flight to the propagation area of a nature not yet understood. It had been noted that at the start of the forward flight (*i.e.* over the canal) the *Anopheles* were forty feet up in the air, and it was possible that the end of the return flight was also above the range of vision. Additional investigation, however, showed that there was a marked return flight and though this happened on several successive mornings, other mornings showed practically no return flight from the village, or houses, to the breeding place, so far as could be noticed. This return flight did not begin until 6.00 A.M. although there was sufficient light to read by ten minutes before that time. The return flight, once fairly started, was of much shorter duration and more rapid than the forward flight. The "night-jars" accompanied the return flight, but were absent on those mornings when no return flight occurred. As the daylight became



To the right, in the foreground is the Y. M. C. A. building. The pale line beyond the lock wall is the near shore of the *Anopheles* breeding grounds. The Atlantic Ocean in the distance is six miles away

Flight and Attraction of Mosquitoes 107

stronger the speed of the returning *Anopheles* increased. The termination of both forward and return flight was remarkably abrupt, or as one observer expressed it, "the flight stops with almost mechanical precision when there is too much daylight or too much darkness."

As already mentioned, the *Anopheles* travel at incredible speed toward the end of the return flight. The only change taking place was the increasing intensity of light. This, together with the fact that when sheltering from the wind or sunlight they will remain hungry rather than fly three feet out into the sunlight to bite a person standing in the sun, but will immediately attack him if he steps into the shade, is at least suggestive. Are both heat and a certain intensity of light repulsive to *Anopheles*, or is it the light only? The latter would seem to be the case under natural conditions, as they do not come out into the sun to bite after 7.00 A.M. One of the observers, Mr. Zetek, noted some males in the return flight, and also found blood in the mosquitoes returning.

During the flight observations Mr. E. F. Quimby conceived the idea of using an apparatus for registering the direction of the flight of *Anopheles* with a view to determining the direction of, and

108 The Control of Mosquitoes

the area covered by, heavy flights. The apparatus is here shown. It consists of four glass plates set in a metal frame; the latter mounted on a

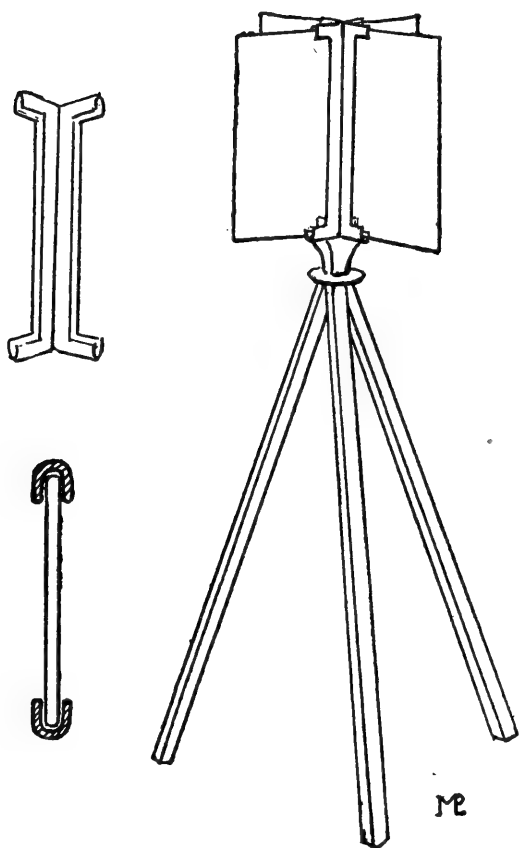

tripod. The plates are set in two vertical planes at right angles to each other. The instruments can be set up so that the plates point north, south, east, and west. The glass was painted with a mixture of resin and castor oil giving a practically transparent coating capable of holding any

A device for showing flight direction of *Anopheles*

mosquitoes that came into contact with it. The solution was made by adding small quantities of pulverized resin to heated castor oil; constant stirring was necessary. The proportions used were one quarter pound of resin to a pint of castor

Flight and Attraction of Mosquitoes 109

oil. The instrument was used and the results obtained checked with the results of personal observations on both forward and return flight, with the exception of one case, where a male *Anopheles* was apparently traveling at least temporarily in an opposite direction from the main flight.

It is possible that where anti-malaria work is to be taken up in badly infested regions observations of flight made in connection with this apparatus will indicate which, of several possible production areas, is the principal source of the particular species of mosquito that it is desirable to eradicate.

One interesting feature in connection with this long-distance flight was that the malaria sick-rate did not increase much although the number of malaria-carrying species of *Anopheles* present in houses increased enormously. Eight men were employed daily catching mosquitoes in houses at Gatun. The indoor catch of each week and corresponding cases of malaria are given in the table on the following page.

Although, as already stated, long flights of mosquitoes on the Isthmus were known to some of us, we were unfortunately unable to trace any individual mosquito and find out by actual observation how far it went, and in what direction. The necessity for this information was apparent.

110 The Control of Mosquitoes

The chief sanitary inspector assigned to Mr. J. Zetek the task of marking mosquitoes in such a manner that they could be recognized. We had previously tried to induce them to mark themselves

| Week ending— | Number of adult <i>Anopheles</i> destroyed in houses. | Malaria cases per week per 1,000 employees. | Percentage of employees sick with malaria. |
|--------------|---|---|--|
| | | | <i>Per cent.</i> |
| Oct. 19..... | 207 | 2.7 | 0.27 |
| Oct. 26..... | 149 | 3.5 | .35 |
| Nov. 2..... | 199 | 4.5 | .45 |
| Nov. 9..... | 404 | 2.5 | .25 |
| Nov. 16..... | 666 | 6.8 | .68 |
| Nov. 23..... | 779 | 6.8 | .68 |
| Nov. 30..... | 3,397 | 6.1 | .61 |
| Dec. 7..... | 3,150 | 10.1 | 1.01 |
| Dec. 14..... | 3,296 | 6.1 | .61 |
| Dec. 21..... | 5,430 | 5.1 | .51 |
| Dec. 28..... | 9,415 | 3.9 | .39 |
| Jan. 4..... | 11,698 | 5.0 | .50 |
| Jan. 11..... | 22,074 | 4.1 | .41 |
| Jan. 18..... | 22,988 | 5.5 | .55 |
| Jan. 25..... | 19,873 | 6.2 | .62 |
| Feb. 1..... | 15,746 | 7.5 | .75 |
| Feb. 8..... | 15,580 | 8.2 | .82 |
| Feb. 15..... | 15,676 | 9.3 | .93 |
| Feb. 22..... | 11,441 | 6.8 | .68 |
| Mar. 1..... | 11,234 | 5.4 | .54 |

Table showing number of *Anopheles* caught in houses at Gatun each week during the heavy influx

with red ink while escaping from cages, but the experiment failed. Fortunately Mr. Zetek solved the problem before the influx at Gatun took place. The method devised for following up the individual mosquito was as follows:

Larvæ and preferably pupæ of *Anopheles* were collected and developed into adults. These were placed in cages, protected from sun or wind, and

Flight and Attraction of Mosquitoes 111

stained with an aqueous solution of an aniline dye. They were given a period of rest and liberated toward evening. Aqueous solutions of eosin, methylene-blue, etc., were used, one gram of dry stain to fifty cubic centimeters of water. An atomizer was used to direct a fine spray upon the mosquitoes. When spraying care was taken to avoid covering them entirely with the stain; only minute particles were allowed to touch them. It was found that too much stain rendered the mosquitoes useless for purposes of experimental flight. The stained mosquitoes were liberated at known distances from the laborers' barracks at Corozal and to the south of it. All mosquitoes noted in the building at that camp were carefully collected; those from each house placed in a separate box, dated and labeled. Later they were placed on a glass plate that rested on white paper and spread out. Each one was treated with a small amount of a solution that dissolved the dye on any stained specimen. When stained specimens were encountered, the color was seen to be present as soon as the testing solution came in contact with it. The solvent for testing consisted of three parts alcohol, three parts glycerine, and one part chloroform. As a result of this method of staining and consequent ability to follow the movement of mosquitoes

112 The Control of Mosquitoes

near Corozal, the previous northward flight already referred to (*i.e.* against the wind) was established beyond a doubt. One of the many difficulties in this work at first was due to seasonal changes.

From time to time the supply of mosquitoes gave out and we had to transport larvæ and pupæ across the Isthmus; many died of the rough handling and shaking unavoidable with inexperienced collectors, and when many larvæ must be collected quickly.

At Gatun, where staining methods were again used to check the flight already observed, we collected mosquitoes in tents near the breeding places, and also tried small paper houses. The work was tedious, and it was difficult to move about in such small places, or to keep quiet while being bitten by hundreds of mosquitoes and still more sand flies. This method of collection was replaced by using mosquito bars. They were hung up in the woods and the lower edges pinned up and kept a few inches from the ground. It was soon found that by occasionally brushing the mosquitoes from the hands, face, and clothing, they would fly upwards and eventually come to rest in the upper part of the net. Sometimes they were but half an inch apart. This method was so



Staining *Anopheles* with aniline dye to determine
length of flight

Flight and Attraction of Mosquitoes 113

successful that other methods of collecting were abandoned.

When the first net was installed the biting was so continuous that after it became well filled with mosquitoes the observers crawled out from under and tied up the bottom of the net. Conditions were becoming unbearable even to those persons who were accustomed to be bitten frequently. Next morning soon after daylight nearly all the mosquitoes within the bar were dead, apparently killed by the drying action of the wind during the night. After this experience, as soon as a sufficient quantity of mosquitoes collected in the upper parts of the mosquito bars, they were sprayed very lightly with aqueous solution of aniline dye and liberated by turning the mosquito bar inside out. This operation was repeated as long as the observers could keep their tempers, and then a general retreat was made to the other side of the canal where there were no mosquitoes.

Very patient negroes were necessary to act as bait under the mosquito bars! Had the boat used for crossing the canal been conveniently near the bait might have escaped. Many of the stained mosquitoes were recovered, and even two weeks after the last catch was stained, some of them were captured near the place where the nets had been.

114 The Control of Mosquitoes

Considering the small number that were stained compared with the enormous number that took part in the Gatun flights, it was not to be expected that many stained specimens would be recaptured. Forty stained specimens were recovered at distances varying from 1200 to 6250 feet from the liberation station:

| | | | | | | |
|----|---------|------|-----|------|------|---------|
| 2 | between | 1000 | and | 2000 | feet | distant |
| 7 | " | 2000 | " | 3000 | " | " |
| 0 | " | 3000 | " | 4000 | " | " |
| 24 | " | 4000 | " | 5000 | " | " |
| 2 | " | 5000 | " | 6000 | " | " |
| 5 | at | | | 6250 | " | " |

At the time of the staining the *Anopheles tarsimaculata* was the most numerous species, although *Anopheles albimanus* and *Culex* were present both at the breeding place and in the flight. Among the specimens recovered, thirty-three were *Anopheles tarsimaculata*; five *Anopheles albimanus*; one *Culex*, and one undetermined. Some of them were captured in mosquito bars under houses. Of the five that made the longest flight, four were *Anopheles tarsimaculata* and one *Anopheles albimanus*. They were caught by an observer under a net placed in the shade of a building 6250 feet from the liberation station.



Anopheles in a mosquito-bar exposed to air currents at night



CHAPTER VIII

ATTACK ON PROPAGATION AREAS BY FILLING

IN beginning anti-malarial work near a village where this work has not been done before, the filling of depressions, etc., that hold water should be accomplished. These places may be controlled by the application of oil or larvacides, but this method is not as good, because the work needs to be repeated at frequent intervals, and also because the personal equation is involved and some propagation areas may be left untreated sufficiently long to produce one or more broods. All small depressions that hold water, including cow-hoof marks, badly cut-up land, wheel-track marks, small ponds that cannot be drained satisfactorily, and flat lands that do not dry with sufficient frequency to prevent the development of pupæ during the wettest periods, should receive attention. There is nothing to be gained by filling depressions having such absorbent qualities that they become dry before a brood of mosquito

116 The Control of Mosquitoes

larvæ can mature. Lowlands that cannot be drained and those parts of extensive swampy land that produce *Anopheles* can often be filled to advantage.

It is also important to enact laws preventing excavation or filling from becoming the source of new broods of mosquitoes. In borrowing material for fills, relatively porous material should be selected, if available, because depressions in a fill made of clay will retain rain-water. If the material is taken from a hillside, the bottom of the borrow pit should be left properly graded.

If seepage planes are suspected, the proposed site of the borrow pit should be examined with an earth augur to determine the depth of any seepage plane that may be present, and the borrow-pit floor must be kept well above the damp soil overlying the plane of seepage. If this is not done it may become necessary, later, to install seepage intercepting ditches to take care of the borrow pit. The finished surface of fills should be properly graded and allowance made for subsequent settlement, which always takes place after filling.

Attempts to cover wet places where subsurface water under pressure is the difficulty will often fail when a fill is shallow, and the entire new fill

may become saturated. If there are but a few springs or sources of water, the fill can be kept dry by making small ditches care for the water. It is more economical and satisfactory to treat flat ditches than to attempt to oil wet grass-covered areas. In the latter case, as the work is performed by laborers who are fatigued by carrying loads of oil in mud and water all day long, we cannot count on their vigilance to ensure the entire surface of every small body of water covered by grass being completely covered by oil. Consequently it is essential to use large quantities of oil and thoroughly saturate all of the wet land. The area of the ditch as compared with the area of the wet land to be filled will indicate the relative cost of oiling each. Small areas are filled by pick, shovel, and wheelbarrows. For larger areas where suitable material is near, drag scrapers or wheel scrapers drawn by horses are used.

On the Isthmus much excavated material was available and many acres were filled by dump cars and Lidgerwood cars from which the material was removed by a plow drawn by a steel rope. On some of the heavy or deep fills made by dump cars the soft land at the toe of the new fills was sometimes thrust up by the weight of the fill or rolled up in front of it. In making fills of

this nature when the heavy rocks roll down the slope faster and go farther than the accompanying earth, it generally happens that a layer of rocks and boulders lies under the heavy fills thus made.

Much of the rock used in filling taken from Culebra Cut decomposes rapidly when exposed to the air, and turns into soil in a few months time. The freshly made dumps are at first sufficiently porous to absorb the rain-water that collects in the low parts of the uneven surface of the dump. However, in a year's time settlement takes place and also the impervious particles of the decomposed rock as well as clay are washed by storm water into the depressions. When the depressions cannot be economically drained it is frequently possible to get rid of the water by leading it down to the spaces in the layer of loose stones at the bottom of the dump. This is done by drilling a hole near the pond and using a little dynamite.

Within a year's time the new dumps on the Isthmus were covered with dense vegetation and had to be frequently inspected as the older they became the more numerous were the small surface pools.

The vegetation may make travel difficult. Sometimes it is burned in the dry season, to facili-

tate the finding of newly formed breeding places at the early part of the wet season when much *Anopheles* production takes place.

After the deep fills are made there is sometimes a considerable flow of water under them, which outcrops near the toe of the fill and has to be cared for, either by an intercepting ditch, or by oiling.

HYDRAULIC FILLS

In digging the canal channel near the Pacific and Atlantic terminals, pipe line dredges were used. These dredges cut the material near the suction end of the pumps and draw it in with the water. This muddy liquid, containing from ten to twenty per cent. of solid material, is then forced through pipe lines for long distances. The lowlands are surrounded by dykes and the liquid mass fills the enclosure. When the surface water is at first drained off, the mass of silt and mud dries very slowly. Its depth may be anywhere from one to ten feet or more.

In many places pools and depressions produce mosquitoes before the fill has time to settle and dry. As the mud dries numerous cracks are formed which catch and hold rain-water. As the drying proceeds the cracks widen from a fraction of an inch to three inches and sometimes are more

than a foot deep. The dried surface soil is at first merely resting on liquid mud and if a person stands on one of the solid portions it frequently sinks beneath him. When the crust becomes thicker, the cracks are more numerous, and so are the numbers of *Anopheles* developing in the cracks after showers. To control similar conditions we installed surface drainage to assist the drying. This had to be accomplished without drowning the laborers. Large sheets of waste galvanized iron roofing were thrown forward and heavy planks used to bridge the space between these sheets and put only light pressure on the thin crust. Shallow ditches were then dug by laborers standing on the planks. They do not prefer work of this nature! This preliminary ditch rapidly dries the soil at its sides so that it will bear a man's weight if he does not stay too long in one place, and it can then be made deeper. The process is repeated until the desired depth and grade are obtained. When the cracks do not become filled by the action of rains, as soon as the crust is sufficiently strong to support a mule, an iron rail is dragged over the surface, to level and fill the cracks. When the material contains much sand or gravel, the cracks do not form.

About one half of the area on which Colon is



Cracks in a hydraulic fill

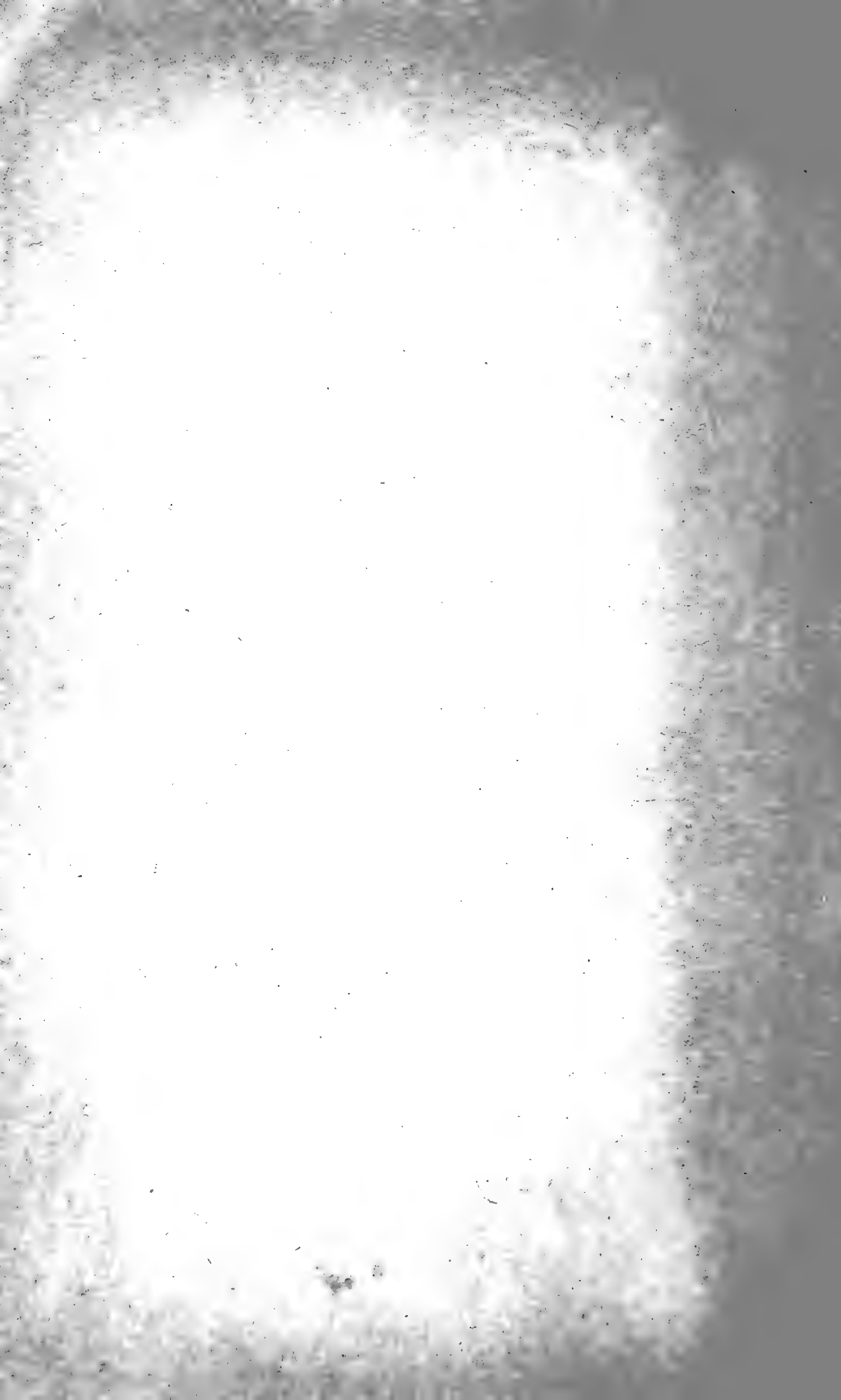

built was filled by this hydraulic method at the request of the sanitary department and is now producing a revenue. The cost of this work at Colon was charged against the sanitary department, but the large ground rents accruing have not been placed to its credit. The extensive area on which the new town of Balboa is being built was formerly a tidal swamp. It was filled by dumping soil from Culebra Cut upon it. It was more expensive to dump waste in that locality than at other established dumps, where it would have served no purpose and had no future value. But the difference of cost of dumping was also charged against sanitation, although the sanitary department has not been credited with the rise in value of property formerly worthless.

The work of filling the large swampy area north of Ancon will be similarly charged. Of course the paper cost of Isthmian sanitation is increased by these charges. After the hydraulic fills near settlements become thoroughly dry and receive the necessary surface drainage, the value of formerly useless property increases.

CHAPTER IX

ATTACK ON PROPAGATION AREAS BY DRAINAGE

GENERAL CONSIDERATIONS

WITHOUT doubt, proper drainage is the all-important and most effective method of eliminating malaria. It should be more generally known that so far as mosquito eradication is concerned, the drainage scheme should be planned with a view to destroying them. The sanitarian and the engineer often look at the problem from different points of view. The sanitarian wishes to eliminate all *Anopheles*-propagation areas permanently. If that end cannot be obtained at a reasonable cost, to ensure success he plans a scheme of drainage which would eliminate or reduce the possible breeding areas as much as possible, keep the annual maintenance expenses at the lowest figure, and eliminate to the utmost conditions favorable to mosquito development and the necessity for continuous future inspection of ditches. Any

scheme that prevents a possible failure due to improper or neglected inspection, or which abolishes the personal equation, is worthy of consideration.

The engineer often has another point of view. He plans the ditches for rapid removal of storm water, but gives no thought to the condition of the ditch between showers, and seldom has any interest in or responsibility for the future success of the mosquito drainage work. The sanitary officer in charge may be replaced by a man inexperienced in *Anopheles* control. The engineer who planned the work may be in another part of the world and probably has not designed his drainage scheme to meet these conditions. In general, he tries to be rid of a body of standing water at the lowest first cost. To him the problem is very simple, and apparently not worth much consideration. He may not be interested in the habits of mosquitoes and is generally ignorant of the fact that small puddles or even a fraction of an inch of water left standing will defeat the sanitarian's object. He may not care if the water in the ditches runs rapidly enough to remove *Anopheles* larvæ, but in the tropics the width of the bottom of a ditch often determines whether it is to be a means of reducing *Anopheles* or of producing an additional supply.

124 The Control of Mosquitoes

If a competent civil engineer devotes his entire attention to these matters, he not only makes a study of details affecting the problem, but will probably invent new methods of procedure and new short cuts. It is not unusual for an engineer to leave minor ditching work to the judgment of a gang foreman, who makes the ditches too wide, spoils the grades, and frequently the work is not only unsuccessful, but expensive to maintain, and ultimately becomes a dangerous source of *Anopheles*. It is possible for an improperly drained area to produce more mosquitoes after the ill-planned work is concluded, than before the drainage was begun.

An ideal scheme of drainage would be a plan to remove all standing water from the *Anopheles*-producing area, and take care of all storm water in such a manner that within a short period after a storm the ground surface and ditches would become dry. These conditions would eliminate *Anopheles* and many other species of troublesome mosquitoes.

In many places in the tropics this ideal cannot be attained, because of such factors as geological formation, texture of surface soil and subsoil, topography, vegetation, the extent and distribution of rainfall, and air movement. The mere fact

that open ditches are not always followed by perfect "*Anopheles* drainage" need not in any way discourage the sanitarian. He must overcome many apparently difficult problems, or his work will not be successful. Open ditches should be made as straight as possible, and have narrow bottoms. The side slopes should be clean cut.

Drains with flat grades may often deteriorate to conditions that actually produce *Anopheles*. Sometimes it is difficult to prevent the formation of "pot-holes" in ditches on heavy grades, and as each foot of open ditch means an item of expense for maintenance, the drainage scheme should be planned to use the least total length of ditches. To attain the best results, we must be sure the drain is correctly located. There is often a choice of locations for a drainage ditch. The character of the surface soil may be such that the necessity for certain branch ditches is doubtful. When working in wet areas it is often best to locate and install the main ditches before the laterals are definitely located. This is especially true of extensive areas covered with water and jungle where the low places are not yet known, and their drainage can be planned better after the deep water has been removed.

Additional advantages ensue in cases where

126 The Control of Mosquitoes

seepage water and springs complicate the problem. Where these conditions are found the use of the herring-bone type of ditch is often unsatisfactory, and the position of the branch ditches may depend to a large extent on the location of the seepage water and the points at which it comes to the surface, "seepage outcrops."

A man who has had extensive practice in drainage for anti-malaria purposes can do much of the minor detail work without supervision, but where grades are light and work extensive, it is essential to have levels taken, to profit by all the existing grade. If ground and relative elevations are judged by the eye alone, wrong conclusions may easily be drawn as to the possibilities of drainage, and it is too late, or at least more expensive, to correct errors after the actual work is well advanced.

It must be kept in mind that some swampy areas, for reasons not yet thoroughly understood, are not sources of *Anopheles*. In other cases they may be the source of non-malaria conveying species. Where possible, without increasing the cost of the drainage work, it is often advisable to determine the most prolific sources of the malaria-carrying *Anopheles*, and to give the drainage of these places preference over other work.

Seasonal changes may affect the production of

mosquitoes, and certain breeding grounds may be harmful only at one short period of the year, or only during the wettest part of an unusually rainy year. The latter condition calls for attention when *Anopheles* originate in water coming from seepage outcrops.

Many problems on the Isthmus differ from those encountered in other parts of the tropics where mosquito eradication or control measures will be undertaken in the near future, and it may become necessary to modify Isthmian sanitary practice to attain results rapidly and economically in other localities. However, it is thought that an outline of difficulties encountered, and a brief account of the methods used to overcome them, may be of assistance to other communities suffering from malarial fever.

OPEN DRAINS OR DITCHES

This type of drain may be divided into two classes: First, those that are intended to carry off storm water during rainy periods, and becoming dry a day or two after the rain ceases, are known as storm-water drains. Secondly, those that carry off water for a period of more than a week, or which hold more or less water continuously.

Some storm-water ditches may fall under the

second classification for varying periods of time during the wet season, depending upon the rain distribution in respect to time or continuity.

Storm-water drains may fail to give satisfactory results because of a tendency of the bottom or sides to scour at times of heavy flow. The character of soil at the bottom and sides of the ditch determines its ability to remain standing with fixed cross-section. It should be remembered that at times of maximum rainfall the ditch water may carry large quantities of gravel and stones, which assist in causing more erosion than usual. Other conditions being equal, the steeper the grade of the ditch the greater will be the tendency to the scouring of the sides and bottom. Soft spots or places are often found along the line of the ditch where the texture of soil lends itself to erosion; and washouts may be expected at these points.

Again, where the ditch becomes temporarily obstructed by stone or otherwise, excessive local scouring action may ensue, removing soil from below the grade line of the ditch bottom, and causing a hole in it. During subsequent storms one or more stones may collect in this depression, and travel with a circular grinding motion, that enlarges the hole. These cavities are known as pot-holes, and retain water long after the storm

ditch is dry. In many cases these depressions may be filled with stone, well rammed into place and chinked, and the original grade of the ditch bottom reestablished before much harm is done. There is a tendency to neglect these holes, and to assume that the ditch is dry and does not need inspection. This assumption would result in *Anopheles* production in the depressions below the ditch grade line.

When ditches contain water continuously, or for periods long enough to bring *Anopheles* larvæ to full development, they must receive regular weekly inspection. During the part of the year when large volumes of water pass off in short periods, the ditches are generally swept free of mosquito larvæ. When the average flow is fairly rapid, the same effect is produced.

It is when the velocity of the water becomes retarded that conditions become most favorable to mosquito development. In open ditches having a rather flat grade such conditions often prevail, and vegetation within them may develop rapidly. Both grass and aquatic vegetation assist in retarding the stream flow, besides furnishing food and hiding-places for mosquito larvæ. The retarding of the current causes silt to deposit and this affords sufficient plant food to make vegetation

grow rapidly, and also raises the grade of the ditch bottom.

Ditches in soft soil and having a low grade are the most expensive to maintain, and may become a prolific source of *Anopheles*. Vegetation on the sloping sides of open ditches prevents the banks from scouring, but when the grass grows long it falls into the water, retards the current, and often assists in making conditions favorable to mosquito propagation. Streams and ditches are treated similarly; by straightening the channel and re-grading parts of the bottom, we confine the normal water flow and increase its velocity, which removes the hiding-places of larvæ.

TILE DRAINS

When rock, hard-pan, or other impervious material underlies the surface soil, the ground water not being able to penetrate it follows downhill on its upper surface, and where the impervious stratum comes to the surface of the ground or close to it, there may be a source of water. When small quantities of water appear in this way on the ground surface, they are called "seepage outcrops." The line where water seeps out of the ground may be short, or may extend along the entire side of a hill, and become the source of a hillside swampy

area. The extent of the seepage outcrop line may vary with the duration of a rainy season. Some seepage outcrops may be permanent, others intermittent, and yet others may be active only for a short time, during periods of excessive rain, and may not become active every year.

The character of the surface soil below the

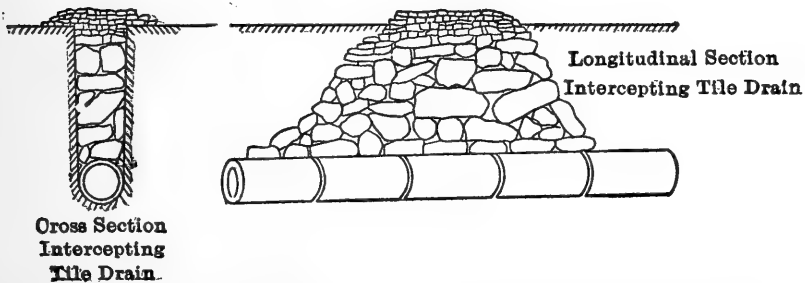

Longitudinal section and cross section of intercepting tile drain.

seepage area may vary. If more or less impervious, water remains on the ground surface, and *Anopheles* are produced. In places where seepage water is commonly found, it is well to examine all sharp changes of grade in surface topography, and the ground near the toes of abrupt slopes. As the rainy season advances, the line of seepage outcrop often moves up the slope, and in controlling this water the highest points of the outcrop must be determined. Under the conditions existing at Panama it was found best, as a general rule, to

132 The Control of Mosquitoes

control seepage water outcrops by tile drainage, with a minimum grade limit of one foot in two hundred. The plan adopted is to intercept the seepage water by tile drains placed approximately at right angles to the line of flow of seepage water.

The line of seepage outcrop is determined during the wet season, when the seepage is most pronounced, and levels taken with an instrument. The proposed ditch to take the tile drain is staked in the field, and a profile map made. The profile, compared to surface conditions, will show any changes that can be made with advantage, and at times it is essential to try out several lines in order to obtain the best and most economical location for the tile drain. When the uphill portion of the tile line had a long steep grade, no harm was done by using a flatter grade for a short length toward the outlet, as the excessive rains in Panama caused the pipes to run full section or nearly so.

The tile ditches are made as narrow as convenient, and their bottoms are kept at the established grade. The openings left between the successive tile lengths are from one eighth to one quarter of an inch, and the joints are not wrapped with muslin or covered in any way. If soft spots are found in the bottom of the trench, stones are rammed into place until a solid foundation is

obtained. After the tile is wedged securely in place the trench is filled with stone to the height of a few inches above the original ground surface. Earth excavated is placed only on the downhill side of the excavation. Small stone is preferable for the top layer of cover stone at the ground surface. This scheme of drainage has given excellent results.

There are conditions under which intercepting tile drainage should not be used. If unforeseen future changes of topography produce these conditions, the tile line will probably operate in an unsatisfactory manner. The soil over the greater part of the Isthmus contains a large percentage of clay. If the lands above the tile line are kept covered with vegetation or left in their natural condition, the surface water running down the hillsides is not heavily charged with clay and silt, and passes through the cover stone above the tile line and then off through the tile. Should the soil be bared or excavated above the tile line, or a hillside road located across the tile line, large quantities of impervious material will be washed onto the cover stone, and fill up all the spaces between the stones, and no water can reach the tile. Tile drains are not planned to meet these conditions, and cannot operate under them without costly maintenance.

134 The Control of Mosquitoes

Under normal conditions the subsurface drainage systems cost practically nothing to maintain. Many of the drains installed seven years ago have received no attention whatever since they were laid, and are doing their work now as well as when new. *Anopheles* are not produced in subsurface drains.

A few essential points to be kept in mind for intercepting tile drainage for *Anopheles* eradication are as follows: No water should be allowed to enter the upper end of the tile drain or of its branches. The grade of the trench bottom should be true; tiles must not be located on soft mud, where they may sink. Where the tile line comes near the surface, due to topographical variations, proper bridge crossings must be made, so that wagons will not pass over and crush the tile. Greasy water and house waste must not be allowed to discharge into any part of the tile line system. If drainage from roadside ditches or excavated areas is turned onto the cover stone, a tile line will probably become useless.

The profile of a proposed line will indicate the amount of material to be excavated, and the depth of the trench. It may often be advisable to use one or more branch lines to include all the seepage water, as the cost of excavation and cover stone may be less than that of a single deep ditch.

The outlet or point of discharge of a tile drain must be well above the ground surface or above the body of water onto which it is to discharge its contents. Much solid matter is transported through the pipe, and may in time block the outlet at the point of discharge. This condition might

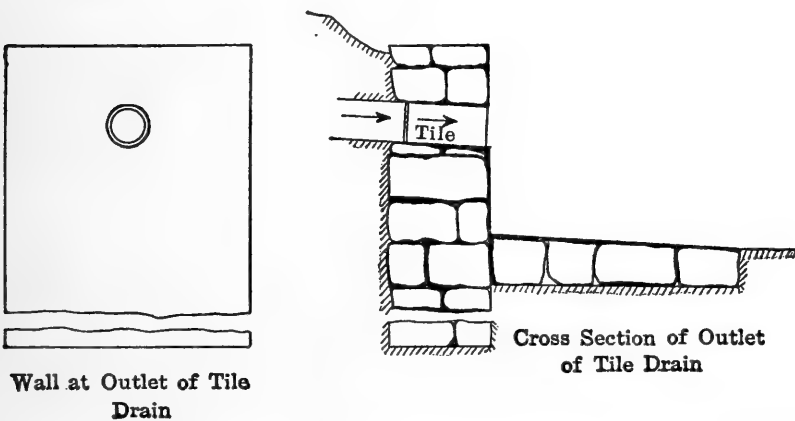

Detail of outlet of a tile drain.

result in the clogging of a part, or all of the line. It is well to arrange for periodical inspection of all outlets, especially where the lower end of the tile line has a relatively low grade.

Branch lines should be connected to the main line by means of Y joints and approach it at an acute angle or on a curve. Water-bearing strata may be deep enough to necessitate the installation of several parallel branch lines placed to prevent seepage water outcrop between the lines of tile.

136 The Control of Mosquitoes

Where seepage outcrops on bare hillsides, or at the foot of slopes where there is insufficient grade for the use of tile drains, open ditches are used. In these cases the water is intercepted as in the

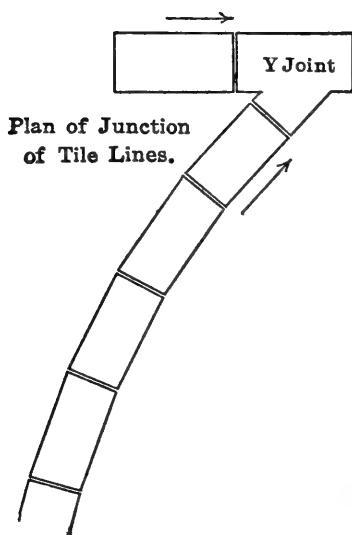

Plan and side view of junction of tile lines.

case of a tile ditch, but the side of the ditch nearest the hill must be given flatter slope than the other side, because it is wet and more apt to break off and fall into the ditch. If such a ditch is expensive to maintain, it should be lined with concrete, and plenty of weep holes left to care for seepage water.

PERMANENT LINING OF DITCHES

The method that is most economical and durable for any special locality should be used. It is often more economical in the long run to line ditches with stone or concrete in permanent villages and suburbs of towns. A ditch may be properly shaped and roughly lined with field stones, and the bottom finished with cement mortar. If a flat V-shaped section is used, it is found best to round off the bottom, so that obstructions will not remain in the ditch and collect other debris. Elaborate or very smooth finish for ditches is not essential.

It may be thought more economical to maintain open ditches than to line them, and in this case the actual cost of maintenance, including cleaning, regrading, and oiling treatment, should be accurately kept. If one or more ditches are lined, a true comparison of cost of the open ditch versus the lined ditch can be made.

Experience on the Isthmus has indicated that in most cases it is better to line permanent small ditches which would otherwise have to receive treatment throughout the year. Before lining a ditch an estimate of cost of lining was obtained, and compared with the estimated cost of maintenance and treatment necessary for the unlined ditch.

138 The Control of Mosquitoes

In some cases lime mortar and rough stone have been used to advantage, with a small amount of cement mortar for a finishing surface, or the bottom was lined with flat stone, the interspaces chinked with small stone and sealed with cement mortar. Where it was necessary to line the bottom of the ditch only, the sides were given a slope beyond the angle of repose, and allowed to become covered with grass. As stone is sometimes costly, the quantity used should be reduced to a minimum.

REINFORCED CONCRETE LINING FOR DITCHES

Where broken stone "screenings" or gravel can be obtained at a reasonable rate, a reinforced concrete ditch of light section may be the best method of ditch lining. In the Canal Zone, a thickness of about two inches is used for small ditches with two-inch mesh hexagonal poultry netting for reinforcing. In one case where a steep embankment slid, a section of seven feet of this lining was lifted out in one piece. It was only necessary to regrade the ditch and replace the section where it belonged. With most ditches it is sufficient to line the bottoms and a few inches up each side, as we are interested in the flow line of the stream only after the rain has ceased.

Work of this nature cost about twelve cents per



Concrete lining of a ditch of small cross-section



Reinforced thin concrete lining of a roadside ditch, and support of sliding toe of hill with

linear foot, in place, for ditches a foot wide, with unsatisfactory labor costing ten cents per hour. Reinforced concrete lining should be selected for

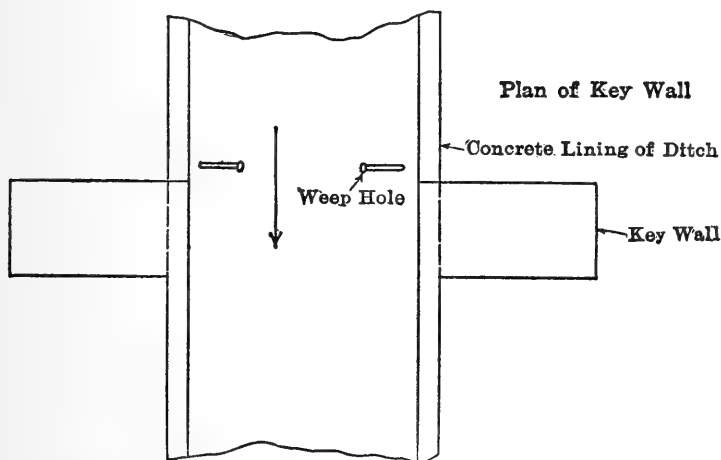
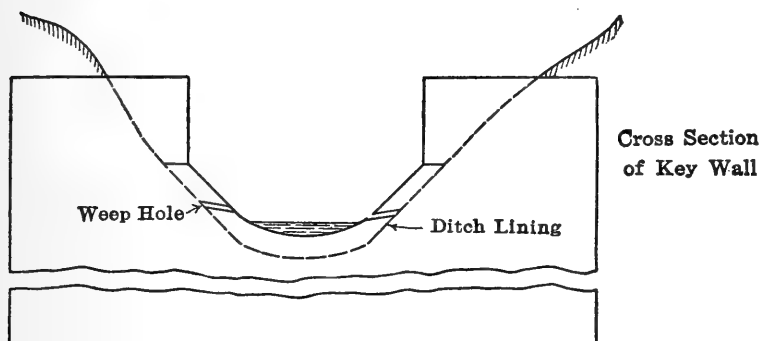

Plan and cross section of key wall and position of weep holes.

ditches near permanent settlements that are possible mosquito producers throughout the greater part of the year. The work should be accomplished during the dry season, and the ditch

140 The Control of Mosquitoes

water temporarily diverted until the concrete has set. A thin layer of concrete about one inch thick should be laid on the prepared ditch bottom, the

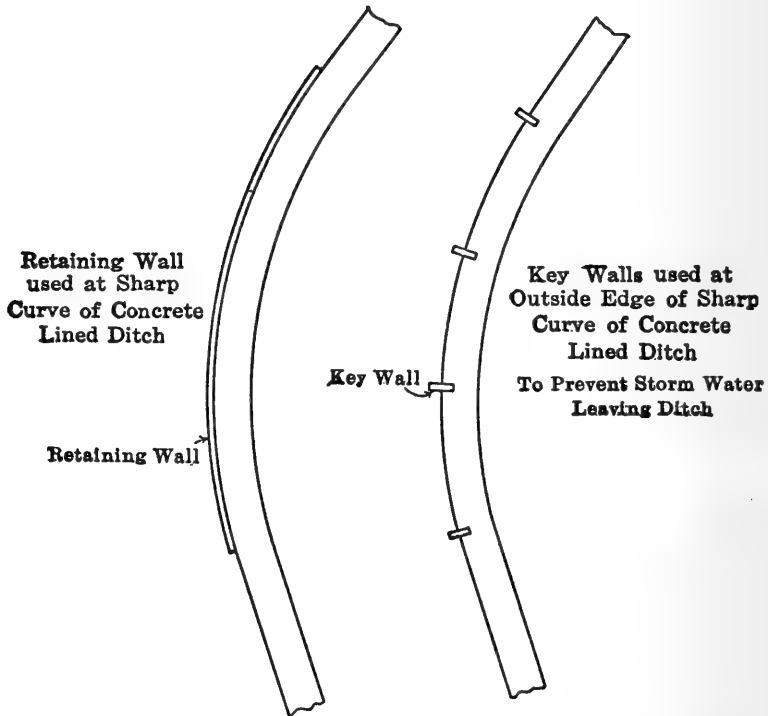

To prevent water leaving lined ditches at bends or sharp curves, key walls are used to break the current, or the outside wall is made higher.

wire mesh pinned down on it, and the second layer of concrete installed, leaving the wire mesh embedded in the concrete. River gravel is as good as broken stone or screenings and sand for this purpose. In larger ditches the sides are sloped, and lined for about a foot above the floor line.



Concrete ditch lining



Concrete-lined ditch at Balboa

When natural watercourses are treated in this way advantageous realignment is first made; and grades are used that fit the topography; in many cases causing the actual length of the stream to be considerably shortened, and its velocity increased.

Whenever ditches are lined, sufficient weep holes

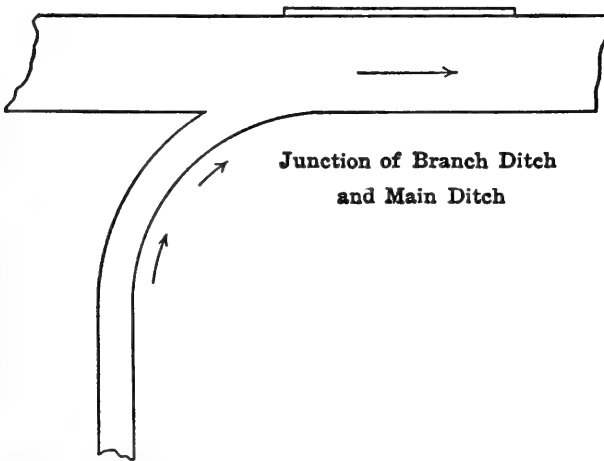

Branch ditches should join main ditches at an acute angle or on a curve.

must be installed to enable the water that follows the sides of the concrete lining to enter the ditch. When weep holes are omitted water is apt to stay in puddles near the stone lining. Water has a tendency to flow along the side walls and under lined ditches. In many instances this is sufficient to tear away the earth supporting the ditch sides and at times even to undermine the lining. This action is prevented by installing key walls at right

142 The Control of Mosquitoes

angles to the axis of the ditch at necessary intervals. Weep holes are placed in the side walls on the upstream side of the key wall, and, if necessary, the key wall can be carried up to the level of the top of the ditch or above it. These walls act as a barrier in time of freshets and break the rapid current that would otherwise tear away the earth banks and make pockets immediately outside the

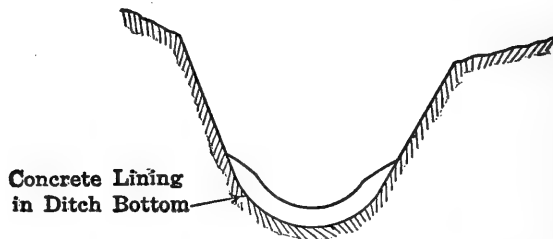

Concrete lining for bottom of small ditch.

ditch lining. On heavy grades it is necessary for the key walls to extend about a foot below the ditch bottom and under the ditch floor, extending well into each bank.

Where weep holes fail to operate because of becoming clogged with impervious material, broken stone can be used to replace the clay near the weep hole. They should always point downward toward the center line of the ditch, or else in extreme dry seasons they become mosquito breeding places.



Junction of concrete ditches, showing splash wall to confine water within the ditch

Where sharp bends or curves occur in lined ditches, and especially on heavy grades, provision must be made to prevent storm water climbing out of the ditch, and undermining a considerable section of the lining. This is easily arranged by introducing one or more key walls on the outer side of the curve, widening the ditch near the point of curvature, or by raising the outer wall in

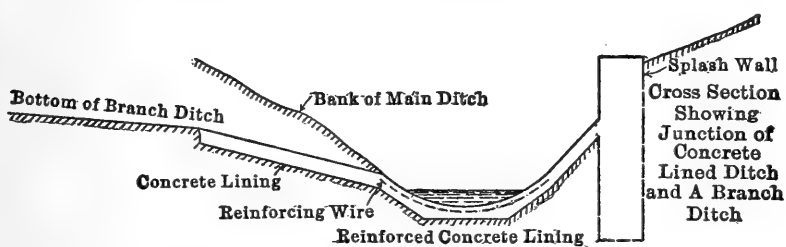

Junction of branch ditch with a lined ditch.

the vicinity of the point of curvature. In small ditches the same result is obtained by decreasing the slope of the outer wall, or making it vertical near the point of curvature.

It is not advisable to have a branch ditch meet a larger ditch and be at right angles to it. It is better to curve the small ditch near the junction of the two so that they meet in a Y joint. If this is not done, much vegetable debris, mud, and stone may be deposited in the smaller ditch. It is well to make the main ditch somewhat wider at junction points, sharp bends, and points of curvature.

144 The Control of Mosquitoes

In wide ditches the stone or concrete floor lining should slope toward the center.

MAINTENANCE OF DITCHES

Maintenance of a ditch implies keeping it in a condition to carry off water and not produce mosquitoes. The work in Panama consisted of keeping the bottom to proper grade, the cross section of uniform width, the removal of all obstructions that affected the velocity of the water, and also vegetable growth and algæ that furnished food and protection for the larvæ. It included treating the ditch with oil and other forms of larvacide when necessary to destroy larvæ, and periodical inspection to make sure that the ditch was in satisfactory condition and free from mosquito larvæ.

In comparing an open earth ditch with a concrete lined one, we found the following advantages in favor of the lined ditch: The velocity of water is increased to such an extent that mosquito larvæ cannot live in it but are washed away or destroyed. The increased velocity prevents the deposit of silt, etc. Each shower cleans the ditch out, and generally removes any debris that has collected. The cross section of the ditch remains uniform. No grass or other vegetation clogs the ditch. Algæ



Burning grass from side of ditch ; crude oil used as fuel



only occurs in lined ditches having practically no grade, and then only at periods of minimum flow. It is rapidly removed by the application of a small quantity of copper sulphate used at the head of the ditch. Food and protection for *Anopheles* larvæ are absent, and they appear to avoid instinctively ovipositing in places where these conditions prevail.

On fair grades there is no necessity for oiling or treatment of a lined ditch. Inspection may be made less often and as rapidly as one can walk. Defects may be noted at a glance. If the lining has been properly planned and installed, there is but little maintenance cost, and in most cases none at all.

Where ditches are practically without grade, and the soil in the higher lands above the ditch is heavily eroded by storm water, as the velocity decreases, the depositing of matter in suspension increases, but generally only a fraction of the amount is deposited in a lined ditch that remains in an open earth ditch. In fact, concrete lined ditches often take care of themselves, and they need very little attention.

The disadvantage of concrete lined ditches is the higher first cost, and in case of construction work, where the topography is being constantly

changed, it is not advisable to install permanent work that must soon be destroyed or covered up.

Under the conditions existing on the Isthmus, the proper maintenance of open ditches is often a difficult task. It is necessary at all times to keep them free from obstructions. Even a small twig caught by an irregularity on the bank will cause other matter to collect and form a temporary dam. When this happens in a ditch of low grade, it may result in the deposit of silt, sand, and clay for one or several hundred yards above the obstruction.

In a deep ditch regrading and cleaning are expensive. The current velocity may be increased on the side of the ditch opposite an obstruction, undermining that bank completely, and depositing large amounts of material at points lower down.

Where a ditch passes through soft material, the channel frequently becomes out of alignment, and constant cleaning and regrading tends to widen it. During dry periods it may develop into a semi-stagnant pool, in which algæ forms rapidly, making a new small temporary ditch necessary within the larger one. The small one has a tendency to close up, and is often destroyed by the first shower. If cattle walk in the ditch, the water in each hoof-print must be separately oiled. In general, as the

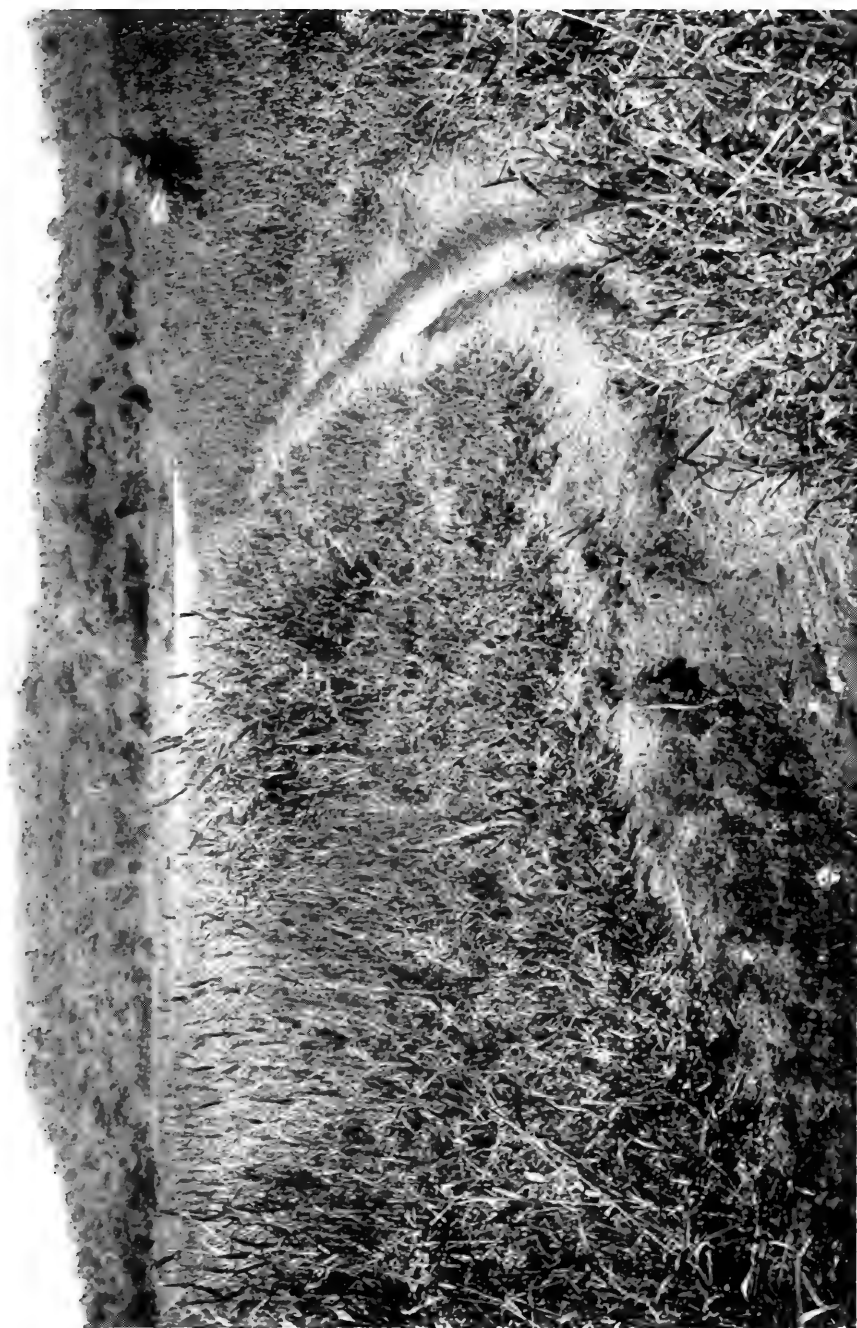

Condition of ditch two months after burning

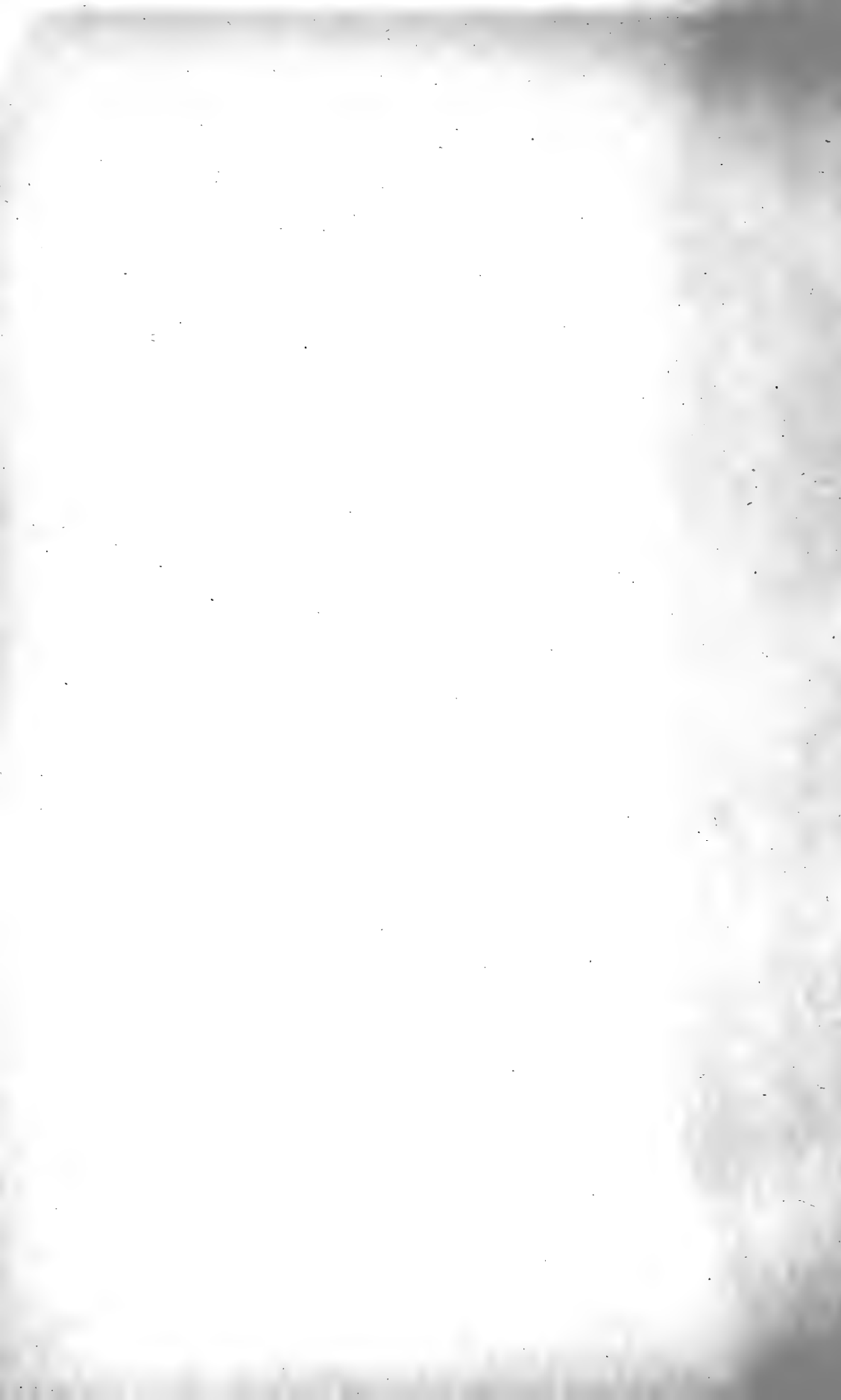

dry season advances, the cross section of the wetted portion of a ditch grows smaller, and little puddles capable of mosquito production are left in the stream bed detached from the oiled water in motion. All these depressions must be separately oiled, and only an intelligent and interested laborer can be trusted to do this. As the quantity of ditch water decreases, the rate of growth of vegetation increases, and it is then necessary to remove it, or smear it thickly with oil to leave the film free from air holes. Then the work must be thoroughly inspected to see that it has been properly accomplished. A sudden shower may remove all the oil and the work have to be repeated.

When the grade becomes flat by removing the vegetation, the ditch may gradually change into a long stagnant pool, and the advantage gained by velocity is lost. It can readily be seen how important it is to have for foreman in charge of the ditching maintenance gang a man who knows the necessity of working correctly, and who can be held responsible for results.

Spoiling the grade of ditches causes more costly future oiling and ditch maintenance. Ditches and streams should have a uniform grade, and as straight a course as local conditions permit. Least

148 The Control of Mosquitoes

larvæ will be found where steep banks stretch above and below the normal flow line. The width of ditches should be no more than is absolutely essential, and the water in them should be kept in motion. Prompt removal of obstructions and attention to minor detail save much future expenditure and reduce propagation. Laborers at work cleaning or regrading a ditch frequently pile the excavated mud in such a manner that sooner or later it returns to its original position. This practice is common along railroads, and laborers should be closely watched to prevent it.

Ditch maintenance gangs often make ditches wider and deeper. On hillsides the banks of ditches are apt to collapse from constant deepening of flood water. This can be partially controlled by giving a proper slope to the ditch sides, allowing grass to grow on them, and preventing holes forming in the bottom of the ditch. As soon as the soft spots are formed, they must be filled with stone, thoroughly tamped into place. When it is definitely known that the erosion cannot be stopped, and that the material carried away will be deposited in the ditch at a point lower downstream, to be removed at regular intervals, an estimate should be made of the cost of constant removal compared with the expense of lining the parts of the ditch being



Ditch cleared by hand labor, showing condition two months after removing grass

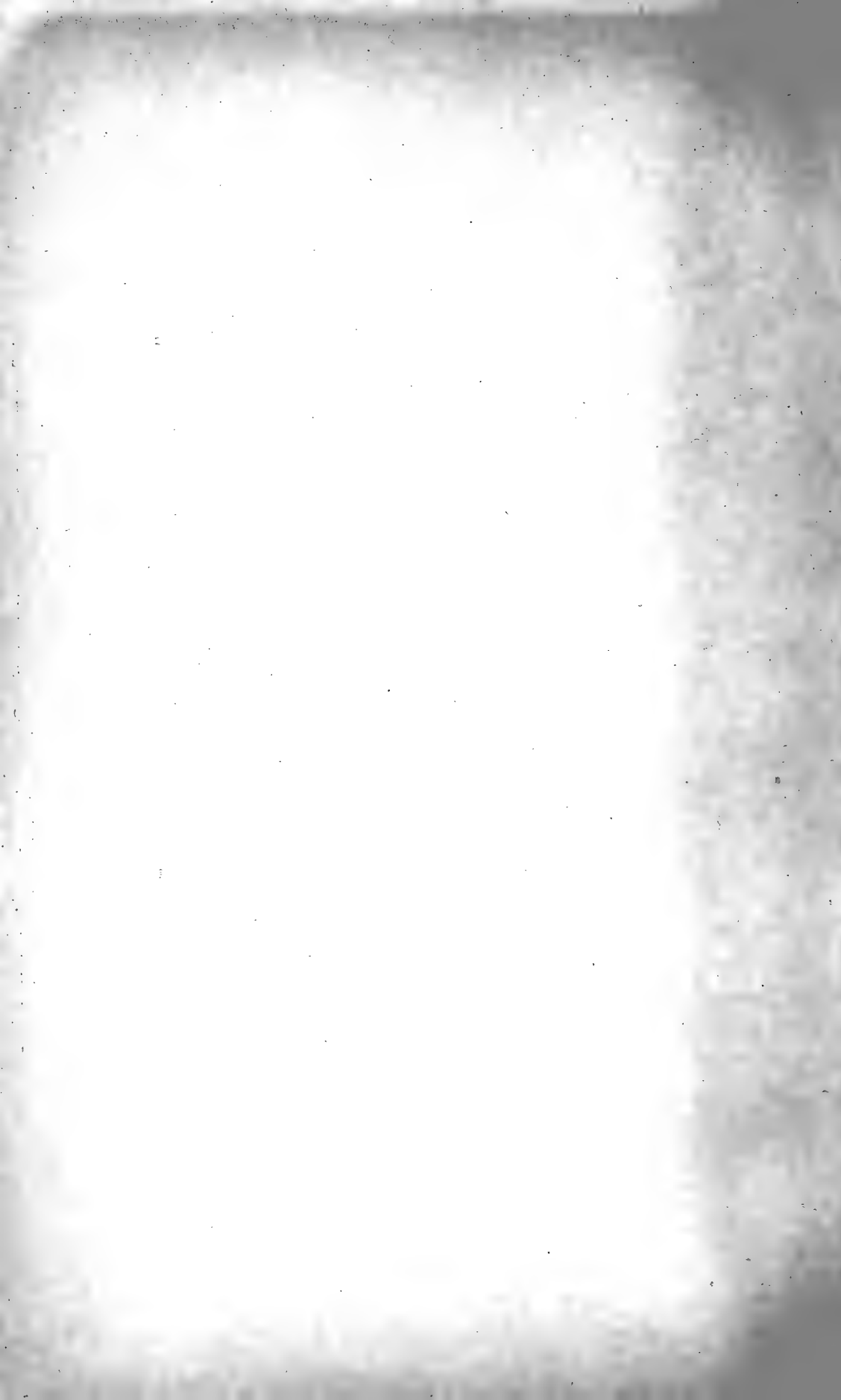

washed away. The grades of pipe lines conveying ditch water under roads or buildings should be slightly more than that of the ditch leading to them. Their entrances should be screened to prevent debris entering the pipe without causing water to be impounded above the pipe at time of floods. A stone or board floor, or apron, at the pipe outlet will prevent erosion.

The stability of open ditches and the cost of keeping them to true grade and uniform cross section with freedom from larvæ depends upon the following factors:

Character of the soil.

Frequency of heavy rainfall.

Grade of the ditch bottom.

Change of grade with corresponding deposit of material carried in flood time.

Presence of seepage water in banks of ditch.

Natural angle of repose of ditch banks when wet.

Presence or absence of vegetable matter washed downstream.

Absence or presence of grass on the banks.

Natural watercourses are classified as ditches, and have to be trained to keep the water at maximum velocity during dry periods.

The question of uniform cross section of ditches has already been referred to, and variations of width in a body of flowing water may not only

150 The Control of Mosquitoes

cause silt, etc., to be deposited, but decreases the surface velocity near the banks in the wider section, and in such places algæ will grow and mosquito larvæ thrive. Near Empire the topography was suitable for the temporary impounding of water, and by placing a gate at the entrance to a culvert, sufficient water was obtained to thoroughly flush the ditch below it and remove all mosquito larvæ whenever desired.

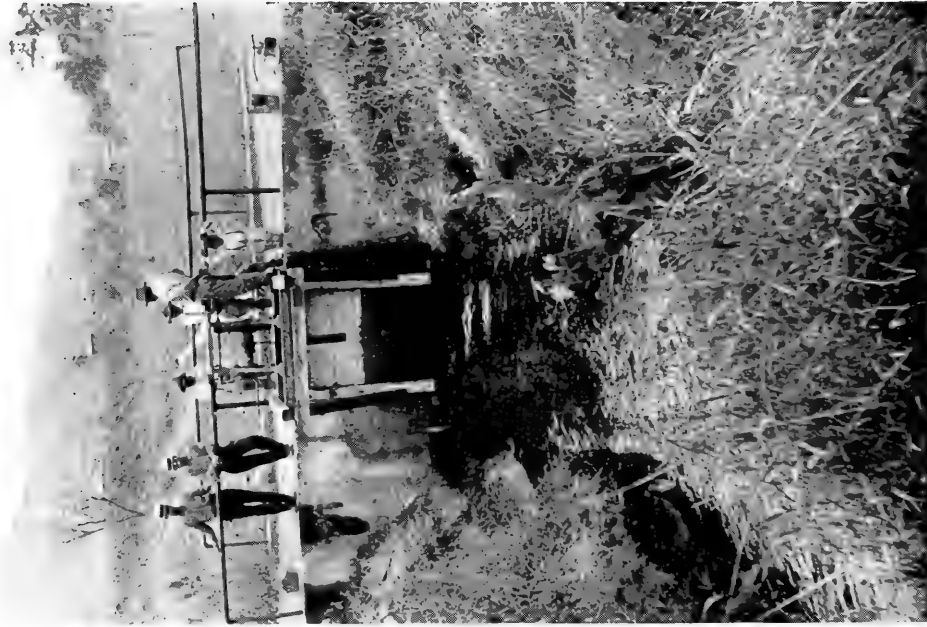

A gate to impound water for flushing a ditch: Empire



Removal and destruction of larvæ and matted algae in a ditch by flushing: Empire

CHAPTER X

ATTACK ON PROPAGATION AREAS BY OILING

UNDER unfavorable conditions larvæ will probably be found in various bodies of water notwithstanding all that may be done by filling and drainage to reduce to a minimum the areas favorable for breeding, and if they are to be prevented from maturing into adults some other method of destruction must be adopted. Oil is the most commonly used larvacide, and being generally applicable is the most useful. Kerosene, crude oils of paraffin and of asphaltum base, and the various distillates have been used, and also crude creosote, eucalyptus, and juniper oil.¹

Just how oil kills mosquito larvæ and pupæ, the writers are not prepared to assert. The generally accepted theory is that oil clogs the breathing tubes of the larvæ and pupæ. Another theory is that by reducing the surface tension, the oil film makes it difficult, if not impossible, for the larvæ

¹ See Ross on the Prevention of Malaria.

to hold themselves at the surface. Possibly a combination of three causes kills the larvæ:

1. Specific toxicity of the oil to the larvæ and pupæ.
2. Minute particles of oil clogging the breathing tube.
3. Reduction of surface tension, making it difficult for the larvæ to remain long enough at the surface to make a rupture in the oil film and thus obtain air.

Oil appears to be toxic to mosquito larvæ. We have observed that a number of larvæ die shortly after coming in contact with it. Mere deprivation of air does not cause death very rapidly in mosquito larvæ. In submerged cages the larvæ and pupæ of *Anopheles* often survive more than an hour.

Probably the minute particles of oil find their way into the breathing tubes, and cause death by clogging. We have seen larvæ take their breathing tubes into their mouths after the contact with the oil and apparently make frantic endeavors to remove some offending substance.

The decrease in surface tension is also a factor, although its importance varies with the various genera of mosquitoes. The *Aedes calopus* can remain at the bottom of a water vessel for a long

time; the *Anopheles* larvæ remain on the surface of the water unless frightened, and are more rapidly killed by the oil film than others.

There is little, if any, ovipositing by mosquitoes on water heavily treated with oil.

Kerosene has its merits. Its especial desirability is its property of rapidly forming a thin film. It was tried in Panama, but rejected in favor of crude oil. The objections to its use are:

1. The film is so thin that very slight disturbances of the water surface, by flotsam, vegetation projecting through the surface of the water, ripples caused by wind or current, etc., break the continuity of the film.

2. Kerosene is expensive.

3. It is transparent, and is wasted by oilers because it is difficult to see where the film is satisfactory.

4. Liability to fire, where sparks may drop into it; for instance, near a railroad.

Crude oil of asphaltum base is used extensively in Panama. Its great advantage is its low cost, and because of that, its poor spreading qualities and high specific gravity may be overlooked in a warm country. We doubt if the quality of oil used in Panama would serve in a cooler country during spring and fall months. The oil delivered in

Panama is imported from California. It averages 20° Baumé. Oil from the same source, testing 30° Baumé, was much more satisfactory, but only a limited amount could be obtained. The crude oil was mixed with kerosene in varying proportions to increase its spreading qualities, but the resulting mixture proved more expensive and less effective for practical field work than treating this particular grade of oil with larvacide which contained phenol compounds. It is possible that some other grades of relatively heavy oils may be more advantageously used after mixing them with kerosene, when its cost is not excessive.

METHODS OF APPLICATION

The methods of applying oil for larvicidal purposes may be classified as continuous or intermittent.

The most serviceable for continuous effect is the "drip method" in which drops of oil fall upon the surface of the water from a specially designed container with sufficient frequency and in such a manner as to form a continuous thin film of oil over a certain area of water. This layer of oil is usually known as the "oil film."

"Drips" are used advantageously where there is a moderate surface current, where the water

surface flows smoothly, where the channel is fairly free from obstructions and flotsam, and where there is very little vegetation and algæ. In a word "drips" are most useful where there are few, if any, impediments to the formation of a good unbroken film. An important advantage gained by using oil drips is that oil is transported by the stream, and left in the form of an oil film on the quiet water along the bank where there is little or no current, and where mosquito larvæ are most apt to be found.

Circumstances occasionally arise which call for the installation of a drip on a stream that does not offer the requirements mentioned. For instance, a rapidly moving, tortuous stream may empty into a quiet, wide pond, in which conditions are favorable to mosquito breeding. This stream may flow close to a road along which oil may be easily transported. The pond may be at an inconvenient distance from the road, and difficult of access for wagon or cart. Under these circumstances, it may be advisable to install a drip on the stream at some point near the road, and by this means carry the oil to the pond, where it is needed. This example shows the possibilities of utilizing a stream as an oil carrier. Our construction camps were frequently situated near sluggish streams or branches

of rivers. Hillside streams from distant hills joined the quieter water near the camp. Larvæ and pupæ were frequently carried by storm water toward the settlement and remained to develop in the quieter water in its vicinity. A rainstorm thus produced a sudden influx of mosquitoes at the settlement. This was prevented by installing oil drips on all streams flowing toward settlements.

The drip may be used on temporary lagoons, as an auxiliary to intermittent treatment. In the rainy season in Panama lagoons are formed in certain depressions from which drainage is difficult. These lagoons rise and fall several feet in a few days. Each fall of the water surface causes the deposit of a large quantity of oil upon the banks, where it is soon absorbed by the soil. After every fall the oil film on the lagoon may have to be restored by reapplication. This is, of course, a great waste of labor and material. In many instances labor and oil can be saved in such places by introducing a few crude rafts carrying drips and moored at suitable intervals in such a way that they will readily rise and fall with the movement of the water, and yet remain in about the same position on the lagoon. The drips automatically maintain the desired oil film, and are replenished from time to time from a punt or boat.

Breeding places for mosquitoes have been found in catch basins of sewers, particularly during long intervals between rains. This condition has been remedied by small drips, but it would be better to use a device making it impossible for mosquitoes to enter catch basins except at the time water flows into the basin.

The measure of success in the operation of a drip is that it shall work as nearly automatically as possible. The ideal drip is one that, once adjusted, requires no further attention except refilling. With heavy oil, the ideal has not been attained in Panama. We were compelled to use drips that worked in a fairly satisfactory manner. Although far from perfection, the drips were extremely useful.

The difficulties encountered in devising a satisfactory drip are:

That crude oil is too thick to permit of making use of capillary attraction, as may be done with kerosene and light oils.

It contains a large quantity of suspended solids, which in time block a small hole or wick, and the flow either stops altogether, or is greatly impeded.

The oil becomes more viscid in the cooler temperature of the night, and may stop flowing until it is warmed later in the morning.

158 The Control of Mosquitoes

These difficulties have been partially overcome by using the following drips:

The simplest form of drip is a vessel with a small hole punched in the bottom. This form is still much used in places where the installation is temporary, as on temporary ditches that are wet

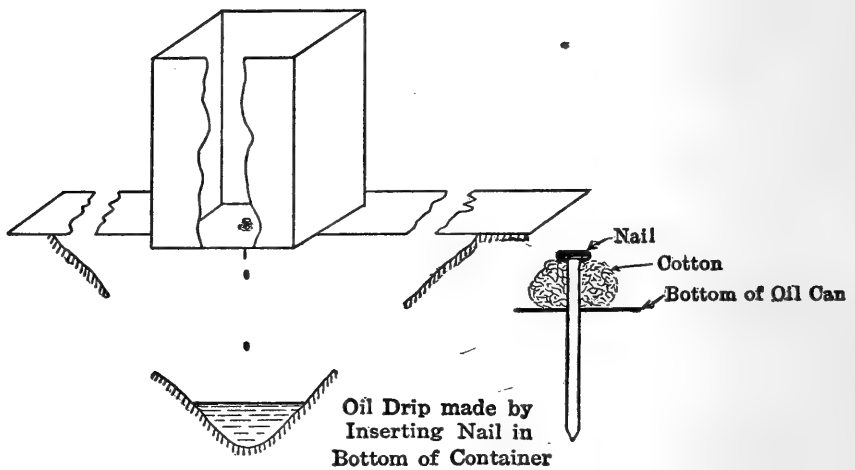

A simple form of oil drip.

for relatively short periods, small pools shortly to be drained, etc. A five-gallon kerosene can is commonly used, having a hole punched in it by a nail. A small quantity of cotton waste is wound around the nail just below its head. The nail is then pushed through the small hole from the inside of the can. The quantity of oil allowed to drip through the opening is regulated by pushing the nail point upward or pulling the nail downward.

Barrels fitted with various adjustable spigots are also used, and work fairly well. The ordinary wooden spigot serves for barrels located on the larger streams.

On the whole, perhaps the most satisfactory drip is one made of a standard garbage can of thirty gallons capacity. A slot $\frac{3}{8}$ inch by $1\frac{1}{2}$ inch is cut in the side of the can about five inches from the bottom. Into this slot a flat spout about three inches long is soldered, and an ordinary lamp wick inserted and made to project inside and outside the spout.

Water is poured into the bottom of the can until it reaches within an inch of the flat spout. Oil is then slowly poured in after previous mixing with about five per cent. by volume of larvacide, the latter thinning the oil. The amount of oil flowing from the can is regulated by compressing or prying open the spout until the drip gives the desired number of drops of oil per minute.

In order to spread, the drops of heavy oil must strike the water surface with considerable force, hence it is best to elevate the drip so that the oil drops at least three feet before striking the surface of the water. On streams having an average width of one to two feet, from ten to twenty drops of oil per minute are applied. The quantity of oil

The Control of Mosquitoes

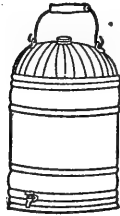

Oil Can used to Drip Light Oils.

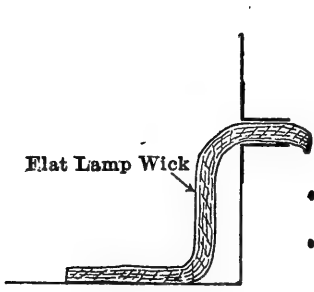

Flat Lamp Wick

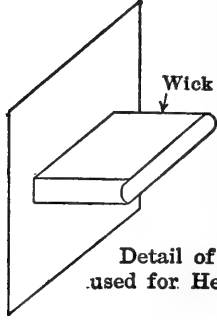

Wick Holder

Detail of Drip used for Heavy Oils

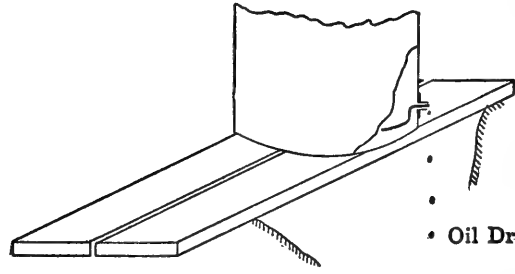

Oil Drip for Heavy Oils

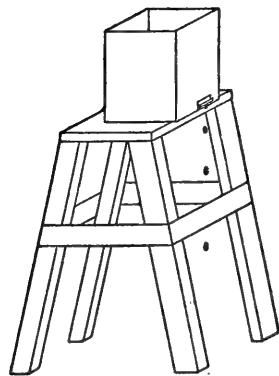

Oil Drip Can Support

The flat lamp wick drip for heavy oils.

required depends upon the spread of the oil, the alignment of the stream, roughness of banks, grade, algæ present, obstructions, etc. For economic control a trial should be made at each ditch or stream where a drip is used to determine the requisite rate of flow. In many cases the drip need only be operated continuously for one or two days a week. On long streams or ditches it was sometimes necessary to use several drip cans, so placed that where the effect of the drip at the source of water ceased, the next drip was installed. Settled dry weather may permit the discontinuance of some drips and allow their location to be changed. The isolated pools remaining in the drying stream bed were treated by using knapsack sprayers.

In practice it was found that drips required periodic attention. Each drip should be visited and adjusted at least twice a week; when new, three or four times a week. Even the best designed drip has required this periodic attention.

Occasionally it may be necessary to install drips on streams subject to freshets. On such streams they should be secured to prevent their being carried off by a flood.

Another way to obtain a continuous application of oil is to use cotton waste impregnated with it. This method has a limited field of application, but

may occasionally be used with advantage. Discarded oil-soaked cotton waste is tied into small bundles, immersed in crude oil, and then placed in small seepage streams and outcrops. If there is danger of its being washed away, it can be tied to a stone. These oil-soaked bundles of waste give a thin film of oil to the water passing by or underneath them during seven to ten days. They may be resoaked in oil and used many times. This method of oiling is used where the volume of water is insufficient to warrant the use of a drip can. Other uses may suggest themselves under varying local conditions.

As the conditions under which continuous oiling can be successfully carried out are rather limited, it follows that the larger part of oil application to mosquito breeding areas must be done by the periodical application of oil or "intermittent method."

In the intermittent method the aim is to produce a continuous film, and to retain it in place sufficiently long to kill all larvæ in the water covered by the oil film. Given a perfect film, it must remain unbroken at least several hours to insure a marked reduction in the larvæ under it. Intentionally we do not say "destruction of all the larvæ under the film," because in the tropics it is



Oil drip applied to hillside stream

not always possible, in the field, to produce and maintain an oil film on a large body of water at reasonable cost that will insure the death of all the larvæ under the film. We have found *Culex* larvæ under an apparently good oil film that had been in place several days in succession. The explanation may be found in the fact that the oil film, in the field, is frequently not continuous, and that defective places may be found in it by which the larvæ and pupæ obtain air. However, a very great reduction in the larvæ may be achieved by proper oiling, and *Anopheles* larvæ succumb much more rapidly than the *Culex*.

The question of how frequently the oil must be applied, can be answered only after a knowledge of local conditions has been acquired. The rule is to oil at least once within the minimum of time required to mature an egg into an adult. In the Canal Zone for the mosquitoes most frequently encountered, this period is about eight days, and oil was therefore applied weekly.

In the intermittent method enough oil must be applied to produce a continuous film, heavy enough to withstand the tearing action of small ripples, and the light flotsam and vegetation projecting through it.

It is difficult, if not impossible, to say just how

much oil must be applied to a given area of water surface. Such an estimate may be made for laboratory work, but it cannot be made for successful field application. Many factors operate to make such an estimate difficult: Wind and wave action; presence of vegetation, grass and brush projecting through the water surface or floating on it, and algæ; the varying density of the heavier oils, the diverse quality of various lots, and the variations in a given lot under differences in temperature. In Panama just enough is applied to attain the desired result.

Where large quantities of oil are to be used, the first consideration, from a standpoint of economy, is the distribution of the oil from its source to the places where it is to be used. The following methods of distribution were used in Panama.

About 600,000 gallons of crude oil have been used annually for the sanitary work in the Canal Zone. The oil was brought from California in tank steamers, principally for use as fuel, and the supply for sanitary purposes was obtained from the oil company. The oil steamers discharged their cargo into storage tanks situated at the Pacific Ocean canal terminus. From these tanks it was pumped across the Isthmus of Panama through pipes owned by the oil company. At various



Oiling obstructed streams on cut-over lands



Brush in valley of Pedro Miguel River. Some Isthmian topographical conditions increased the cost of transportation and treatment to several times the initial value of the oil



points on the Isthmus this oil main was tapped, and smaller storage tanks connected with it. Part of the oil used was obtained from the storage tanks at various places along the line, either directly, or by running small branch pipe lines from these tanks to smaller ones nearer the areas where the oil was to be applied. Part of the oil supply was transported in two railroad tank cars to places where connections could not be economically made with the trans-isthmian oil line. These tank cars were filled at the Pacific storage tanks, and discharged their cargo into small tanks at various points. The aim was to have the tanks as near the ultimate destination of the oil as possible, but an adjacent location was sometimes impracticable, because of the absence of railroad and road facilities. The tanks were properly covered, their faucets kept locked, and sand was piled near them for fire protection purposes.

From the small tanks the oil was transported to the points where it was to be applied, through pipes, in mule-drawn tank carts, in canisters, on mule back, or rolled in drums or barrels. Where none of the above methods was feasible, it was carried by hand, or on the backs of laborers.

The Isthmian topographical conditions frequently raised the cost of transportation and

166 The Control of Mosquitoes

application to several times the initial value of the oil.

Heavy oils are best applied to water in the form of a stream or spray. When applied in this manner, the tendency to form a film is much greater. A number of pumps on the market are entirely satisfactory for this purpose. The pump found most satisfactory in the Canal Zone was called a "barrel pump" and was especially strong. The smaller types of hand boiler-pumps are also serviceable. The requisites of a good pump for heavy oils are simplicity and strength of construction, and valves without rubber.

It will be found occasionally that the heavier fuel oils, those below 25° Baumé, are too thick for the pumps ordinarily used. These oils may be thinned by adding kerosene, two per cent. by volume of crude carbolic acid, or five per cent. of the "larvacide" described in this chapter. Other compounds of a character similar to the "larvacide" can also be used.

A "knapsack sprayer" of the type used for spraying in orchards has given satisfactory service. This knapsack is made of heavy galvanized steel, or of copper; it contains a small powerful pump and has a capacity of five gallons. It pumps very satisfactorily the asphaltum base



Application of larvacide or oil by knapsack sprayer: Miraflores



fuel oil used in Panama, about 20° Baumé, provided five per cent. to ten per cent. by volume of larvacide is added.

The advantages of its use are that oil may be applied properly on the water surface wherever desired from one to twenty feet from the operator.

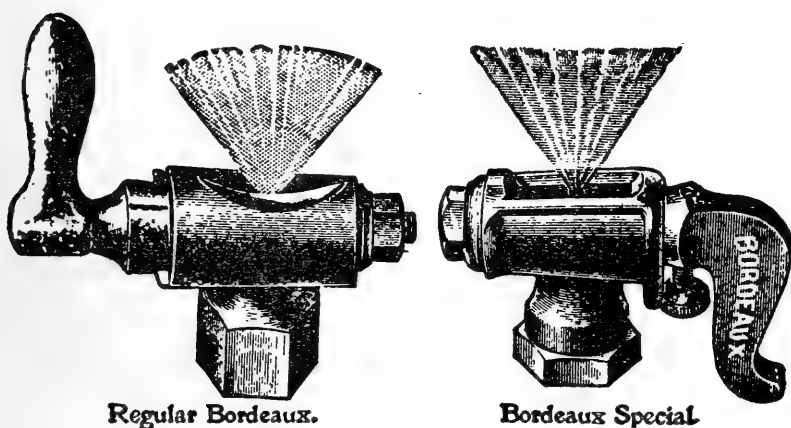

Spray nozzles.

He pumps with one hand and directs the oil-stream or spray with the other. The work is less tiring than using a watering can, and while traveling over rough ground the laborer has both hands free. No oil is spilled or wasted by too rapid application.

It is not necessary to have the spray as fine or its particles of liquid as minute as those used in the application of insecticide. All that is desired is that the oil should spread rapidly upon the water and form a thin film.

168 The Control of Mosquitoes

Oil may also be applied by using a garden watering can; this method is useful where a very heavy layer of oil is desired, and where the places to be treated are accessible.

In oiling shallow waters inaccessible from the shore, a flat bottomed boat with an oil tank may be used. The boat may be propelled by a small motor, or by hand, and may have a motor or hand-driven pump. A spray nozzle of the type shown is very useful, and saves time.

Two and four-wheel horse carts of special design are used on the Canal Zone for applying oil. The carts were designed by Mr. H. R. Trask, an inspector in the sanitary service of the Canal Zone. They consist of iron tanks, holding two hundred to five hundred gallons of oil, mounted on suitable wagon gear. To the lower sides of the tanks are attached three-inch pipes leading to a transverse pipe mounted in front, at the feet of the driver. This pipe is ten feet long, and the outermost three feet of it is perforated with three rows of one-eighth-inch holes set an inch apart. The pipe is mounted with a universal joint, and is controlled by a leather-operated valve. It is raised and lowered by a pedal. In addition, each cart is provided with a large valve at the back, for withdrawing the oil.



Field supply tank



Oil cart for applying oil to roadside ditches



These carts are very useful where they can be driven, and save much labor in transporting and applying oil. The illustration shows their construction.

They are especially useful in applying heavy coatings of oil to roadside ditches, for inhibiting vegetation, and preventing collapse and erosion.

They may also be used for transporting oil from the storage tanks to service tanks and drip devices.

In the jungle covered country of the Canal Zone, there are many places where the lightest of carts cannot penetrate, and yet are accessible to pack animals. These animals carried two fifteen-gallon cylinders of oil fastened to the regulation pack saddle. These little tanks are provided with a two-inch screw stopper for filling, and a one-inch spigot for discharging. The pack mule is especially useful when filling drip barrels situated on streams flowing through the jungle, where only trails can be used. Trails had to be cut for the mule, but the trouble was repaid. One good mule carried as much oil as six porters on each trip, and in less time. The photograph shows the pack mule which has done valiant service in the cause of sanitation for about five years. The equipment shown is of the simplest type.

After the oil is sprayed on the water, the

170 The Control of Mosquitoes

problem of keeping the oil film in place arises, for on water surface of more than a few square feet the oil film tends to drift to leeward under the impulse of a moderate air current, and leaves much water uncovered.

The tendency to drifting is very difficult to overcome. Various devices are in use, all being modifications of the "boom" principle used by lumbermen to catch log drifts. The simplest method is to anchor planks at intervals of five or six feet at right angles to the prevailing wind movement. Where the winds are variable and strong, a wooden grille may be employed, with spaces inversely proportional to the wind force.

Stumps, brush, grass, and stones projecting through the oil film tend to form oil-free rings around themselves by their oscillation, and by the breaking of the ripples against these obstructions. All such obstructions should be removed from areas to be treated with oil.

The heavier oils in conjunction with algæ form a tangled heavy mass, and while some of these masses sink, many do not, but remain on the surface, and produce defects in the film by drifting with the surface current. It is well to remove all algæ from water to be oiled.

When heavy oil is poured repeatedly and liber-



Pack mules, for oil transportation in jungle trails

ally on the common grasses, their growth is inhibited and in time the grasses die. This property of the oil is used to advantage on the sides of ditches and in shallow depressions where water stands during rainy periods, when draining and filling is not economically feasible.

Oil in any form is not an entirely satisfactory larvacide for the following reasons:

Its effectiveness depends on a perfect film. Films are unreliable. Perfect films can be obtained only under exceptional circumstances, and even a perfect film frequently develops defects.

The larvacidal action of oil is slow. In some instances several hours must elapse after the oil is applied before the larvæ of *Culex* are killed. During this time many opportunities may arise for the development of defects in the film. The light oils are expensive, and the heavier oils do not always spread well, unless treated in some manner to decrease their specific gravity and viscosity.

A relatively large amount of oil is needed to cover a given water surface, thus increasing the cost of handling, especially where the oil has to be transported a long distance by hand.

There is always more or less danger from fire, while the oil is in storage.

The application of oil in the quantity necessary

172 The Control of Mosquitoes

to kill mosquito larvæ spoils water for use for domestic or industrial purposes.

For certain purposes, however, oil is very useful, and in the absence of a more acceptable larvacide, the sanitarian must depend largely upon it.

The defects of oil were soon recognized in Panama, and persistent efforts made to find a more desirable larvacide. The product named "larvacide" in Panama was thus introduced, and although short of perfection, is under many conditions superior to oil.

CHAPTER XI

ATTACK ON PROPAGATION AREAS BY LARVICIDES

THE requirements for a good larvicide are:

1. That it shall be of high toxic power, so that a small quantity may suffice for a large volume of water. This requirement is important for its economic use in water lying far from roads and trails.

2. That it shall kill rapidly, preferably in less than ten minutes, that rain intervening, and consequent dilution and weakening, may have as little effect as possible.

3. That it be uniform in its toxic power and capable of standardization.

4. That it shall mix freely with brackish and alkaline waters.

5. That it be harmless to man, and domestic animals, when in the dilution necessary for larvicidal action.

6. That it shall not be susceptible to rapid deterioration through age, and exposure to the

174 The Control of Mosquitoes

air or light, *i.e.*, it must have good keeping quality.

7. It must be inexpensive.

A number of commercial products now on the market satisfy these conditions to a large extent. Many of these have been tried and a few have proved equal to some of the requirements. Others were frauds. None fulfilled all the requirements desired. All commercial products were quoted at high prices. The larvacide we finally adopted cost one half less than commercial products.

While working out the problem of a satisfactory larvacide, Mr. Jacobs, the chemist of the Board of Health laboratory in Panama, suggested the following formula for a larvacide:

| | |
|----------------|-------------------|
| Resin, | 150 to 200 pounds |
| Soda, | 30 pounds |
| Carbolic acid, | 150 gallons |

This product is a black liquid resin soap, that freely emulsifies with fresh water. In brackish or alkaline water emulsion does not take place.

The active ingredient of the larvacide being carbolic acid, to secure uniformity in the larvacidal power of the product it is necessary that the active constituent of crude carbolic acid, phenol, shall be uniform in quantity. It is found that the best



The larvacide plant at Ancon

results are obtained with a content of not less than fifteen per cent. phenols. In order that the finished product may neither float nor sink rapidly to the bottom, but diffuse through the water uniformly and with fair rapidity, the crude carbolic acid should have a specific gravity of about 0.97.

The process of manufacture is as follows: One hundred and fifty gallons of the carbolic acid is heated in a steel tank fitted with a steam coil. When the acid is steaming hot, two hundred pounds of powdered resin is added and the mixture continuously stirred by means of a paddle agitator, until complete solution is effected. Thirty pounds of caustic soda (sodium hydroxide) is dissolved in six gallons of water, and this is added to the resin-carbolic acid mixture. The heating and stirring is kept up for about five minutes, and then a sample of the product is withdrawn, and poured into water. If complete and rapid emulsion results, the larvacide is ready and is withdrawn from the mixing tank into shipping drums. If emulsion does not occur, or is incomplete, the heating is continued until a sample emulsifies satisfactorily.

Each lot of carbolic acid should be assayed for phenol content. Carbolic acid containing less

than fifteen per cent. of phenols, or of a greater specific gravity than 0.97, will not make a satisfactory larvacide.

From time to time, preferably from each lot, a specimen of the larvacide should be tested for its larvacidal powers. If a 1 to 5000 emulsion does not kill full-grown *Anopheles* larvæ in ten minutes, the product is unsatisfactory.

This larvacide, however, loses some of its efficiency when exposed, in emulsion, to the action of the air, and still more when exposed to contact with algæ and other organic matter. Under the latter conditions its efficiency is lowered considerably after twenty-four hours' contact, and after a few days' exposure its larvacidal power is practically extinct.

The advantages of this phenol-resin soap larvacide are:

1. High toxicity to mosquito larvæ. A 1 to 5000 emulsion kills full-grown *Anopheles* larvæ in from three to ten minutes.

2. Concentration. Being effective for practical use in a 1 to 5000 emulsion, only a relatively small quantity of the larvacide need be transported to a given body of water.

3. Uniformity of toxic power. This product, when carefully made, is uniform in toxicity.

4. Simplicity of composition. The manufacture of this larvacide requires neither complicated apparatus nor highly skilled labor.

5. Low toxicity to higher animals. It is practically harmless in ordinary dosage or in dilution to cattle, poultry, etc.

6. Rapidity of toxic action. When used in the field, it killed all *Anopheles* larvæ and pupæ in ten to twenty minutes.

7. Cheapness of the product. In Panama, the cost is about eighteen cents a gallon.

8. Absence of danger from fire. The concentrated larvacide is inflammable, but not easily ignited. In dilution it is not inflammable.

9. It is useful in the rapid determination of the presence of mosquito larvæ and kills those at rest embedded in the mud.

10. In addition to its toxicity for mosquito larvæ the phenol-resin larvacide is also highly toxic to protozoa and algæ, as well as most of the varieties of the common grasses encountered in Panama. The algacidal and herbicidal properties of this larvacide are of frequent use in mosquito eradication.

The disadvantages of this larvacide are:

1. It does not emulsify and is inert in brackish water. This is a serious disadvantage because

178 The Control of Mosquitoes

many *Anopheles* breed in brackish water and *Culex* breed in salt-water marshes and pools. This defect, however, is shared by all the commercial larvacides tested on the Isthmus.

2. The pure larvacide deteriorates upon exposure to the air and must be kept in drums, barrels, and other tightly closed containers.

3. It rapidly loses its toxicity after mixing with water containing algæ and other organic matter. After twenty-four hours its toxicity is so far diminished that it is practically non-toxic from the standpoint of field practice.

The ideal mosquito lavacide should, in addition to possessing all the desirable qualities of the phenol-resin soap described above, possess none of the disadvantages enumerated. We have not yet found such a product, either on the market or by experimenting with various mixtures.

The toxic action of the pheno-resin larvacide upon mosquito larvæ is probably due to the action of its phenol content upon the protoplasm of the larvæ, probably intensified by the fact that the phenol is in emulsion.

We have had practical field experience with Pyrocresol. In composition and action this product closely resembled the pheno-resin larvacide

manufactured in Panama. Its greatest disadvantage was variability of toxicity. Some samples were practically inert. The cost of this larvacide is considerably higher than the cost of the product we used.

CHAPTER XII

ATTACK ON PROPAGATION AREAS AND ADULT MOSQUITOES BY NATURAL ENEMIES

PROPAGATION AREAS

SMALL top-feeding fish which prefer to obtain their food at or near the water surface are of great value in reducing the number of mosquito larvæ that would otherwise pupate. It was frequently observed that they seemed to prefer the full-grown larvæ and pupæ. Many different kinds of these fish are found in all parts of the Isthmus, in rivers, streams, and drainage ditches connected with them. On the arrival of the dry season they were often left stranded in small puddles and died as these became dry. While fish remain in small bodies of water they greatly assist in reducing mosquito possibilities, but if the water in the pool contains much green algæ the small fish destroy only a portion of the larvæ. Where larvæ can hide easily, fish catch the fewest.

In ditches, streams, ponds, and at the edges of lakes and rivers the less the amount of debris, grass, algæ, or other obstructions, the more useful the fish become. It follows that in countries where rank vegetation and algæ are produced rapidly, fish are less reliable as destroyers of mosquito larvæ than in more northern climates.

During the first American anti-malaria campaign at Havana, fish were of greater assistance, and reduced the mosquito propagation more than in the Canal Zone. Large amounts of finely divided debris with bits of twigs and leaves are washed down the streams during heavy downpours of rain and collect in the lakes and quiet parts of rivers. The constant winds collected this material and concentrated it. At these places small fish were nearly always to be seen, and darted about catching the larvæ as soon as the sheet of debris was stirred up or disturbed. By dipping out and stirring a small portion of it in a white enamel pail *Anopheles* larvæ in all stages of development were seen as well as large pupæ; it was evident that the fish caught but few of the larvæ so hidden.

When portions of green algæ are detached from the stream bank, fish invariably follow the floating mass and work hard for the few larvæ they catch. They cannot penetrate the mass, nor

pass through the small openings into which the larvæ dart. When larvacide is applied at the edges of streams, mosquito larvæ sometimes escape beyond the treated zone and are immediately snapped up by fish. When rainstorms remove the algæ, debris, etc., and break up the hiding-places in streams and ditches, the fish are most actively employed and have a feast. In quiet waters they pick up the larvæ that venture far from their hiding-places.

In one instance two solid embankments were placed across the Corundu River and extended from Diablo Hill to Balboa. Between the embankments was a large flat area of about five hundred acres. During the rainy season much water collected in it and was followed by a change in the character of the vegetation.

One of the growths was a moss-like weed that had not been seen before. It grew in the water to within an eighth of an inch or less of the surface but did not quite reach it. There was enough water above the growth to support *Anopheles* larvæ, but not sufficient for the fish to swim in. This area was about a mile south of Corozal and was not treated until it had produced thousands of full-grown larvæ. This happened before the flight of Isthmian *Anopheles* was understood as it

is to-day, but the adults that traveled against the breeze to Corozal were tracked back to this source. Small fish were useless in this case, they could not reach the larvæ.

In certain parts of the Bas Obispo River during the dry season, shallow water varying in depth from an inch to a foot ran over a bottom covered with stones and gravel. A thin film of oil was generally present, but seemed in no way to interfere with the numerous small fish. We knew that mosquitoes were still there in spite of oil and fish. The film was apparently inadequate to suppress many of the larvæ, probably owing to free air spaces on the downstream side of some of the partially exposed stones.

In the camps affected by this river the malaria fever rate had been higher in the dry than in the wet season. At all other camps in the Canal Zone we had more cases of fever in the wet season. When a heavy application of larvacide was given to this moving water, numerous *Culex* and *Anopheles* larvæ immediately appeared at the surface. Some of the fish affected jumped out on to the banks and the remainder were killed. Since that time the local fever rate during the dry season has not exceeded that of the wet season, and year after year the adjacent camps have had few mosquitoes

and a very low fever rate. These instances in which fish alone have not proved satisfactory are not intended to give the impression that fish are of small service in combating mosquitoes, but to show that on the Isthmus recently developed methods of control are more swiftly effective than nature's methods of more limited control. Fish are most useful under many conditions, but the places in the tropics where their control reaches perfection are limited. Undoubtedly if all fish were removed the number of adult mosquitoes including *Anopheles* might become so great as to be unbearable and many places would be uninhabitable.

We believe that the introduction of the proper species of top feeding minnows into lakes and large ponds would be of decided advantage for purposes of mosquito control in countries less favorable to mosquito propagation than Panama, and that the introduction of fish should be accomplished and the species selected with care, after consultation with those competent to give advice regarding fish propagation.

Probably in the near future artificial control of mosquito propagation by means of top feeding minnows will be used extensively. Many miles of drainage ditches on the seacoast meadows of the

State of New Jersey are now being kept entirely free from mosquito larvæ by small fish.

In Isthmian practice we examine places for larvæ. If fish are able to give us satisfactory results so much the better, if not, then fish must be temporarily sacrificed to prevent human suffering. To profit as much as possible by fish control in general mosquito reduction, the sanitary authorities introduced the *Girardinus pæcillodes* of Barbadoes into the Isthmus. This is a small fish commonly called a "top minnow" which feeds at the water surface. The female is about an inch and a half long and is a rapid breeder. It was bred successfully in tanks. The young were liberated in the reservoirs, rivers, and ponds and at various parts of Gatun Lake, but not in places where fish were unable to control the situation and larvacide and oil were used.

Tadpoles were found in cow hoof-prints when water was present, but the Isthmian species did not reduce the larvæ in the depressions and observation failed to prove their value as mosquito destroyers. The larvæ of dragon flies and water beetles were of great value and were found in places of a temporary character in which fish could not live long and were not found. Probably other aquatic insects were of value.

DESTRUCTION OF ADULT ANOPHELES

Spiders are useful as destroyers of mosquitoes. Because mosquitoes prefer to rest on dark surfaces, a black band two feet wide was painted on the walls of the barracks at Balboa between three and five feet from the floor that they might collect where they could easily be reached by the men employed to catch mosquitoes. The walls above and below this band were white. It was noted that after the black band was applied spiders collected on it while they were not to be seen on the white paint.

Certain insects are caught and held fast when they rest on spider webs, but it is not definitely known that *Anopheles* and other mosquitoes on the Isthmus are destroyed in this way. They may be caught by spiders while at rest on or near the webs.

Anopheles appear to have no difficulty in leaving the strand of a spider web which they have selected for a resting place. Thousands of spiders and millions of ants are to be seen on tall grass and weeds growing in shallow water on the Isthmus and they probably destroy many newly emerged mosquitoes.

The small lizards of different colored markings,

found in Cuba and on the Isthmus, are constantly catching mosquitoes. They collect insects out of doors on the patio walls as well as indoors, and after watching them at work, we were satisfied that they should be propagated or at least protected in every way possible. Near Havana in the afternoons they come out on the whitewashed walls and never miss a mosquito that dares to alight within fifteen feet. They often take four moves forward accompanied by rests, before making the final rapid dash at the mosquito. Sometimes they patrol the walls from about four o'clock until dark, and are hard at work again in the morning when the mosquitoes come out of the rooms and settle on the walls.

In the Canal Zone they were found in the old French barracks. Cunnette camp, near Empire, held more than other camps. The buildings are on posts about six feet from the ground and one or more of the little brown lizards with brownish orange colored heads can be seen on the house walls at any time. One of these little fellows if kept in a screened room would take care of any mosquitoes or flies entering when the door was temporarily opened, or carried in on clothing.

Small ants destroy mosquitoes whenever they have the opportunity; they even interfered with

our mosquito trap experiments and caged mosquitoes at the experiment station. As soon as they find a mosquito trap there is a constant stream of them going to and from it and when they have disposed of the dead mosquitoes they begin on the live ones. One ant catches a mosquito by a leg and almost immediately others come to assist. In one instance they were seen catching a mosquito larva in the cup of water at the base of a banana leaf.

The "night jar" is the most interesting of the numerous birds that feed on mosquitoes while in flight. At Gatun, these birds invariably appeared just before the evening flight began. And in the morning they could be heard at the settlement, and followed the returning flight from the settlement back to the breeding place. They disappeared when the morning return flight stopped. After dusk it was too dark to see how late they fed.

Bats destroy large numbers of mosquitoes near houses. Before the houses on the Isthmus were screened they passed back and forth through the balconies, and the flight range extended only a short distance beyond the house. Since the balconies were screened they have been more numerous between half-past six and seven o'clock, which is the time the *Anopheles* assemble on the

screens. They invariably fly back and forth in wind-shaded gullies containing brush, where mosquitoes are more numerous than on the adjacent higher land. In these sheltered places when *Culex* were swarming about the observers and biting them, the bats approached closely, while when they were not being bitten by mosquitoes the bats were fully ten feet away.

CHAPTER XIII

ATTACK ON PROPAGATION AREAS BY CLEARING BODIES OF WATER

BY removing vegetation, algæ, and drift from bodies of water, much of the food and most of the protection of *Anopheles* larvæ are withdrawn. Under normal conditions these larvæ prefer to remain at the surface of the water where they find their food.

Where vegetation in the water is plentiful, it is difficult to use oil effectively, and in order not to leave any air holes large quantities must be used. Vegetation interferes with the spreading of the oil film; it also interrupts the action of the larvacide. When rank grasses come up through the water it is not easy to see if the oil film is satisfactory or not. In moving water, such as ditches and streams, where the vegetation is removed the current velocity is increased, and tends toward washing the larvæ away; and by leaving no hiding-place during rainstorms, the stream or ditch can be swept clear of larvæ.

Another advantage is that fish and aquatic insects that prey on the larvæ have no difficulty in capturing them and under these conditions are extremely valuable in eradicating them. In large ponds and at the edges of lakes where larvæ are frequently found it is often necessary to remove all vegetation in the water, and along the shore, if it will ultimately reach over into the water. Once this is accomplished the fish will keep down mosquito propagation until the vegetation again becomes rank, or until algæ gives the required protection. The application of small quantities of copper sulphate along the shore or periodical applications of larvacide to the small area infested with algæ will destroy it. Lagoons and many streams of slow current contain water surface vegetation, such as leaves of lilies, etc., which affords excellent protection to the larvæ of both *Culex* and *Anopheles*. *Culex* are seen in large patches under these conditions and may be so close together as to form a black mass of thirty or more square feet. This takes place even when there are fish. When all vegetation is removed, additional fish arrive and the larvæ soon disappear. To sum up the advantages to be gained, the clearing of water may increase the stream velocity, destroy the food supply, remove the hiding-places, enable fish to become

more useful, and produce conditions that cease to attract the mosquito.

Most species of *Anopheles* will not deposit their eggs in bodies of water that would be unfavorable to their complete development. They shun localities that expose them to natural enemies, lack of food, drying up of water, etc. The difficulties in clearing bodies of water on the Isthmus are the rapidity with which certain grasses grow up through the water and along shore, and the rapid formation of algæ in shallow water exposed to the sun. Where the bottom of a pond is soft some of the grasses may be pulled up by the roots by means of long-handled potato hooks, and give little future trouble. On the Isthmus various attempts have been made to prevent the growth of vegetation, but no satisfactory economical and permanent method has yet been devised. Preparations containing arsenical compounds were tested both in the dry and the wet seasons, in ditches, ponds, and depressions on low flat lands that became dry. The results were never permanent, although in some cases vegetation was retarded for several months. Certain grasses that run flat along the ground and throw out roots at each joint grew over ground recently treated with arsenical compounds without forming roots,



Removing vegetation from overgrown streams:
Machetes are used



Screened verandas: Ancon

but as soon as they reached the water in a ditch their roots penetrated the soft mud. Experience indicated that the results obtained by applications of grass and weed destroyers in the dry season were better than similar treatment in the wet season. In some instances Bermuda grass was planted, or encouraged, in order to replace and kill other grasses and plants that grow taller and are more troublesome and costly to control.

When it was purposed to use lands near settlements in the Canal Zone for reservoirs, etc., the edges were cleared of vegetation and debris, before the water rose, and the grass was cut very short just above and below the proposed water surface elevations. All dead vegetable matter on the ground to be flooded that might float on the water surface was collected and burned.

As a result we had bodies of water that were relatively free from floating timber, sticks, leaves, debris, etc., and with edges in a condition that allowed oil or larvacide to be rapidly and economically applied whenever and wherever necessary. Near small or temporary camps where conditions did not warrant much expenditure of funds, the trees in lagoons and flooded areas were not removed. Under the above conditions it was found best to remove brush, grass, and floating sticks and

194 The Control of Mosquitoes

debris, which afford better protection to mosquito larvæ than is given by standing trees. When trees are not standing close together, unless their branches reach the water surface, collections of debris are not apt to gather and remain near them.

In the absence of an oil film small fish devour most of the larvæ close to the tree trunk. After the tree decays and falls, its twigs and branches may tend to collect floating debris and afford protection to larvæ. In the tropics vines and plants may grow on floating logs and become the nucleus of floating islands.

CHAPTER XIV

ATTACK ON PROPAGATION AREAS BY REMOVAL OF JUNGLE

MANY square miles of jungle in the Canal Zone have been removed since the American occupation, including all camp and town sites with their surrounding cleared areas, and charged against sanitation. In 1904 some of the houses could not be reached without cutting a way through the intervening jungle. This first clearing was made by using the "machete," and the native laborer is at his best in using this instrument. Until this clearing was made, it was impossible to locate the breeding places near settlements, or to follow up streams or small natural watercourses. The seepage areas, pools, and water-holding depressions were frequently covered and hidden.

Clearing uncovers many propagation areas, and when the sun and wind act on the cleared spaces, evaporation is greatly increased, and numerous small ones become dry before a brood of

mosquitoes matures. It also facilitates inspection and enables the location and extent of the seepage outcrops to be determined. It shortens the effective length of the wet season so far as mosquito production is concerned, and makes it possible to locate all new small temporary production areas that may exist during excessively wet periods. We found it advisable to clear the ground before locating ditches, to ensure their correct placing. The jungle was so thick that on relatively flat lands it was impossible to determine the position of the low places by inspection, for when wandering around in the brush it is easy to lose all sense of direction. Adult *Anopheles* and other mosquitoes rest in the shade, and the removal of the jungle reduces the number that enter dwellings. Clearing made it impossible for the negroes to throw containers into the tall grass or brush near their houses without detection. They were accustomed to throw them away and would carry unserviceable containers a long distance to dispose of them rather than put them in the nearby garbage cans! We cut pathways along the edges of streams and ditches, cleared the edges of ponds, and removed grass from puddles and wet lands to facilitate the application of oil and larvacide. Much of the clearing in lagoons had to be done

from boats. In wet periods certain grasses and plants grew an inch or more per day, and the work had to be done repeatedly over the same territory.

Toward the end of the dry season, spaces were cleared by fire, whenever they could be burned over without danger to property because of the trade winds that assist in spreading flames. Near all permanent settlements where the topography permitted, the ground was prepared for using mowers, and on some steep hillsides heavy spikes were used on the wheels to prevent the machines from sliding downhill. This was especially necessary where the hillside terminated at the abrupt canal banks. At times, when the tall grass needed cutting, the ground was so soft that the use of horses meant the creation of many new breeding places by hoof-prints, etc. If the grass remained uncut, evaporation was retarded and mud breeding aggravated conditions.

The day's work had to be arranged according to weather conditions.

CHAPTER XV

SCREENING AND PRACTICAL DESTRUCTION OF ADULT ANOPHELES IN HOUSES

SINCE Sambon and Low with their two companions lived for three months in their screened hut in Ostia, Roman Campagna, where malaria is usually prevalent, without contracting it, attention has been directed to the possibility of securing protection from mosquitoes by protecting the dwellings with mosquito-proof material and a variety of fabrics have been used in various places and many details of technique have been elaborated. After many experiments, both in the laboratory and in practice, the methods of mosquito-proofing described are now used in the Canal Zone, where screening of dwellings has been carried out on a scale never attempted elsewhere.

Because of the atmospheric humidity and the salt laden air it was found that only the best copper gauze will resist corrosion and subsequent deterioration. The copper gauze used in the

Canal Zone must have not less than ninety per cent. of pure copper, and not more than one half of one per cent. of iron. The cost of this screening is approximately fifty cents per square yard for the 18 mesh, No. 31, B. W. G. gauze, *i.e.*, gauze having eighteen strands of wire of one one hundredth of an inch diameter in each linear inch, which is the number of strands necessary to reduce the apertures to a size that will not permit the passage of *Aedes calopus* and the smaller specimens of *Anopheles* and *Culex*, and yet retain reasonable strength of material and open space area.

Verandas are usually screened as shown on the photograph. In the tropics the veranda is practically the living room; people usually spend their evenings in it, and it must be screened. Aside from the fact that screened verandas contribute very largely to the comfort and probably to the health of the occupants of the dwellings, screening on verandas is easier and cheaper to maintain than the screening of many doors and windows that would otherwise have to be screened. And because of their larger air and light admitting area, screened verandas do not exclude quite as much air and light as screened doors and windows.

A decided advantage is gained by having but one door through which mosquitoes may enter.

200 The Control of Mosquitoes

Unless near a wall mosquitoes do not congregate about the door of a screened veranda as they do about a screened door in a solid wall. They are too busy examining all the screened surface to concentrate at its entry.

If there is a prevailing wind direction during the mosquito breeding season it is advisable to have the balcony door on the windward side of the house.

Where windows have to be screened, the sashes, shutters, and frames are so arranged that a permanently fixed screened frame can be fastened in place. Sliding screen frames are very unsatisfactory in practice; they warp and refuse to shut tightly, they cost more to install and maintain, and are often left open.

A light solid door, well designed and made, and rapidly self closing is preferable for a mosquito-proof house. In damp countries such doors should be made of close-pored lumber, well dried and carefully filled and varnished, or painted, and designed to reduce to the minimum the tendency toward sagging, warping, and swelling. The doors should be provided with efficient self-closing devices, and they should open outward to frighten away any mosquitoes resting on or near the door or hovering in the vicinity. Occa-

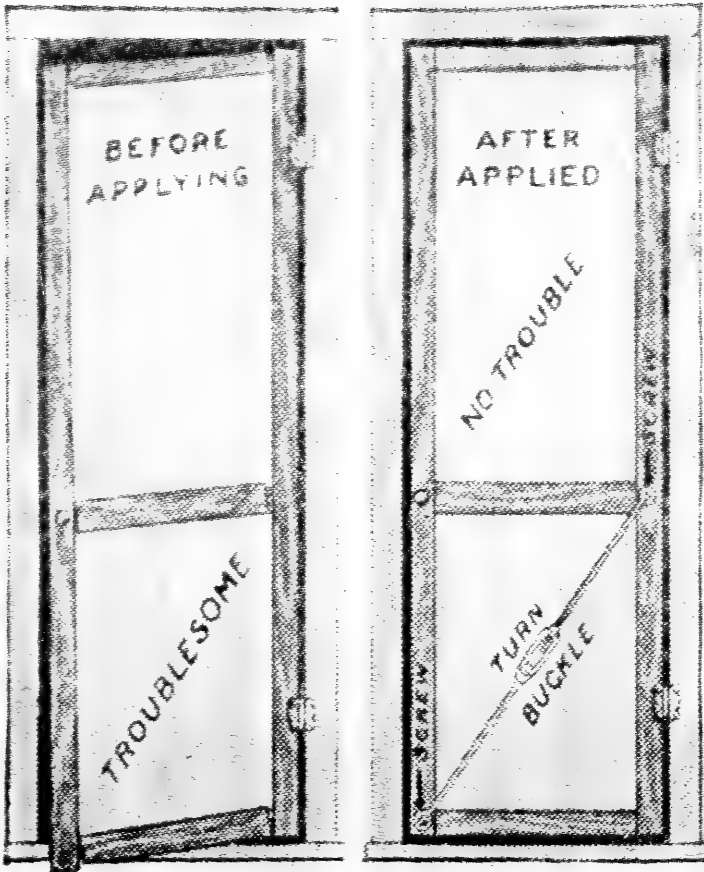

A good device to prevent the sagging of screened doors

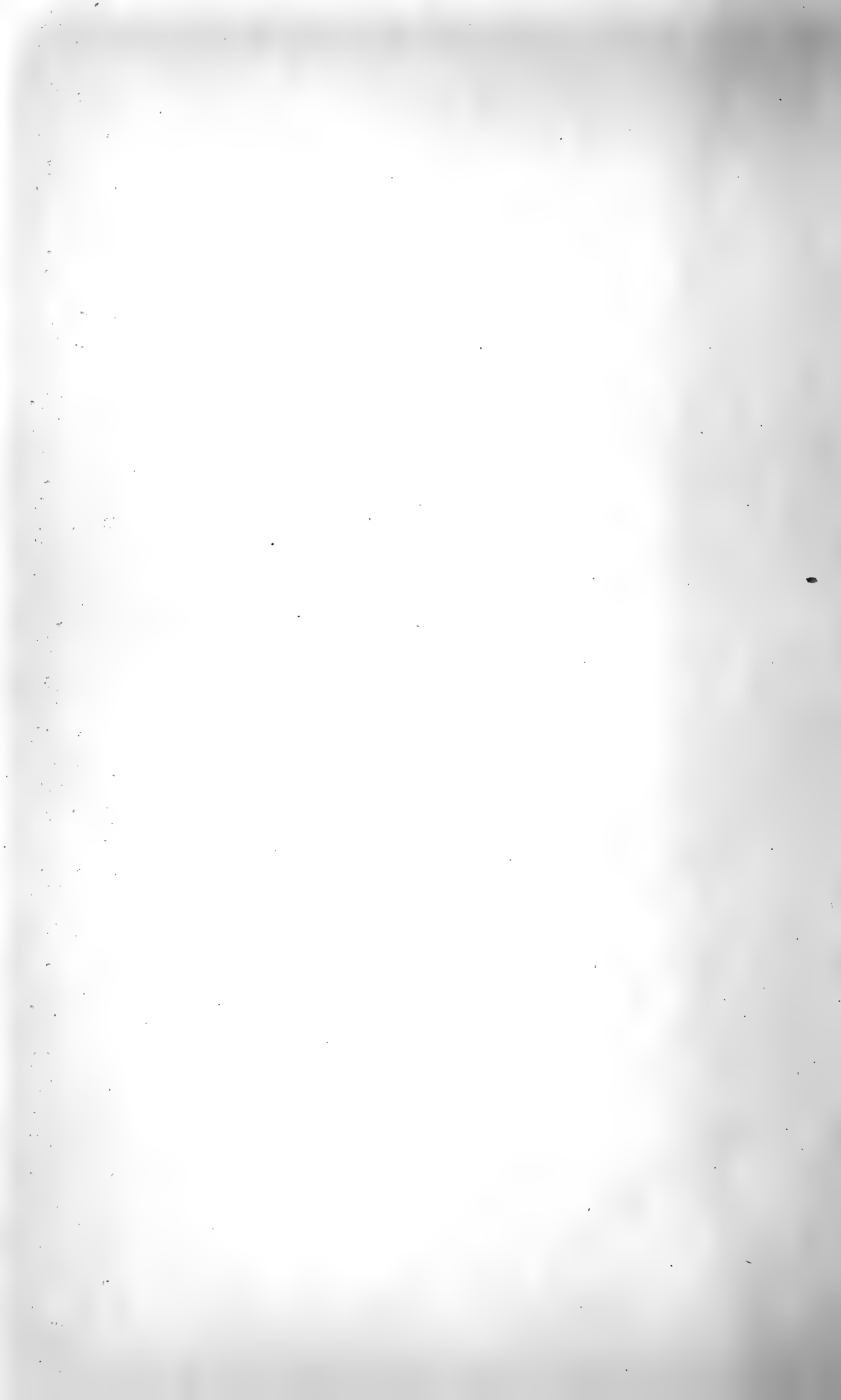

sionally, when mosquitoes are very numerous on hospital buildings, especially yellow fever wards, it is desirable to double-guard the entrance by providing a screened vestibule. Such a vestibule should be at least six feet wide from door to door, and should be arranged so that one door must be closed before the other can be opened. A number of devices will readily suggest themselves. One that has been used with considerable success is a pulley and rope arrangement.

If screened doors are to be used, the frame should be made of light material that will resist warping and swelling, and should be provided with a brace to prevent sagging. A good contrivance for this purpose is two rods connected by a turnbuckle. One free end is fastened at the upper corner on the hinge side of the door, and the other free end to the corner diagonally opposite, as shown on the diagram opposite. Tendency to sagging is corrected by twisting the turnbuckle.

The screen panels should be protected from injury by hands and feet by fastening over the gauze on the outside of it, so as not to interfere with any mosquito catching that may be required, one quarter inch or three eighths inch galvanized wire netting made of wire sufficiently thick to resist denting by a push of the hand or foot against

the panel. Screen panels should not be more than three feet wide and eight feet long. Wider or longer panels resist wear less satisfactorily.

The screening should be fastened with copper tacks to prevent galvanic action, and the edges overlaid with wooden strips three-eighths of an inch by one inch, and fastened with galvanized wire nails. The tacks should be placed at least one half inch from the edge of the screening. The screening should be drawn as tight as possible, without the aid of special stretching devices; *i.e.*, it should be stretched tightly enough to prevent denting and consequent breaking in cleaning, but not so tightly as to put immoderate strain upon the strands bearing against the tacks.

It was found advantageous to protect in a similar manner the lower panels of verandas, the lower parts of the panels above hand rails, panels immediately adjacent to doors, and other panels subjected to hard usage by the inhabitants. Strips of wood have not proven satisfactory in the protection of screening. They have the inherent defect of interfering seriously with the success of mosquito destruction within the houses.

When screening is kept clean, by frequent removal of the dust and the products of corrosion, the amount of light and air excluded by the eigh-

teen-mesh gauze used on the Canal Zone is negligible. The best proof that screening does not materially interfere with the comforts of the house occupants is the fact that not a single complaint has ever been heard on that score from the people on the Zone.

It was occasionally necessary to use tents and railway cars for quarters. The method of making tents mosquito-proof was as follows: A matched lumber floor is laid, and on this are built up the sides of a framework of two by fours, with the necessary doors. These frames are screened. The ridge pole is formed by two vertical two by fours, and one horizontal member, properly braced. Brackets of the right length and height are fastened to the wall frames at intervals. The tent is fastened to these brackets by pulling it tightly over the upper horizontal members of the wall frames, and fastening it to the members by clamping strips of wood to form mosquito-proof joints. Over the tent roof a fly is drawn, and its edges fastened near the ends of the brackets to leave a space of at least fifteen inches between the tent and the fly edges.

In the railroad construction camps, screened cars are used. The cars are screened in the same manner as the dwellings. The illustration shows

some of these cars. A camp consisting of screened cars, and a tent hospital screened in the manner outlined above, have been in use for about four years. Although *Anopheles* were very numerous, as shown by the daily catches in the cars, and although very little oiling, etc., was done in this locality, the screening, plus daily catch of mosquitoes in the cars, kept the malaria incidence to almost the average incidence of the Canal Zone.

The crucial point about screening is the thoroughness with which the work is done, and the constant vigilance and care that must be exercised in speedily detecting and remedying defects. Mosquitoes, and particularly *Anopheles*, will readily find a very small aperture in their endeavor to enter a house to find blood, but once within a house, the mosquito very seldom, if ever, finds its way out again unless doors or windows are open. A screened house with rents in the screening, cracks in the floor, openings between the plate and roof, or any of the many imperfections of mosquito-proofing, is a veritable trap, and from the point of view of the protection of its inhabitants from mosquitoes, more dangerous than an un-screened house.

A perfectly screened house may yet offer in-



Types of screened houses: Colon Hospital grounds

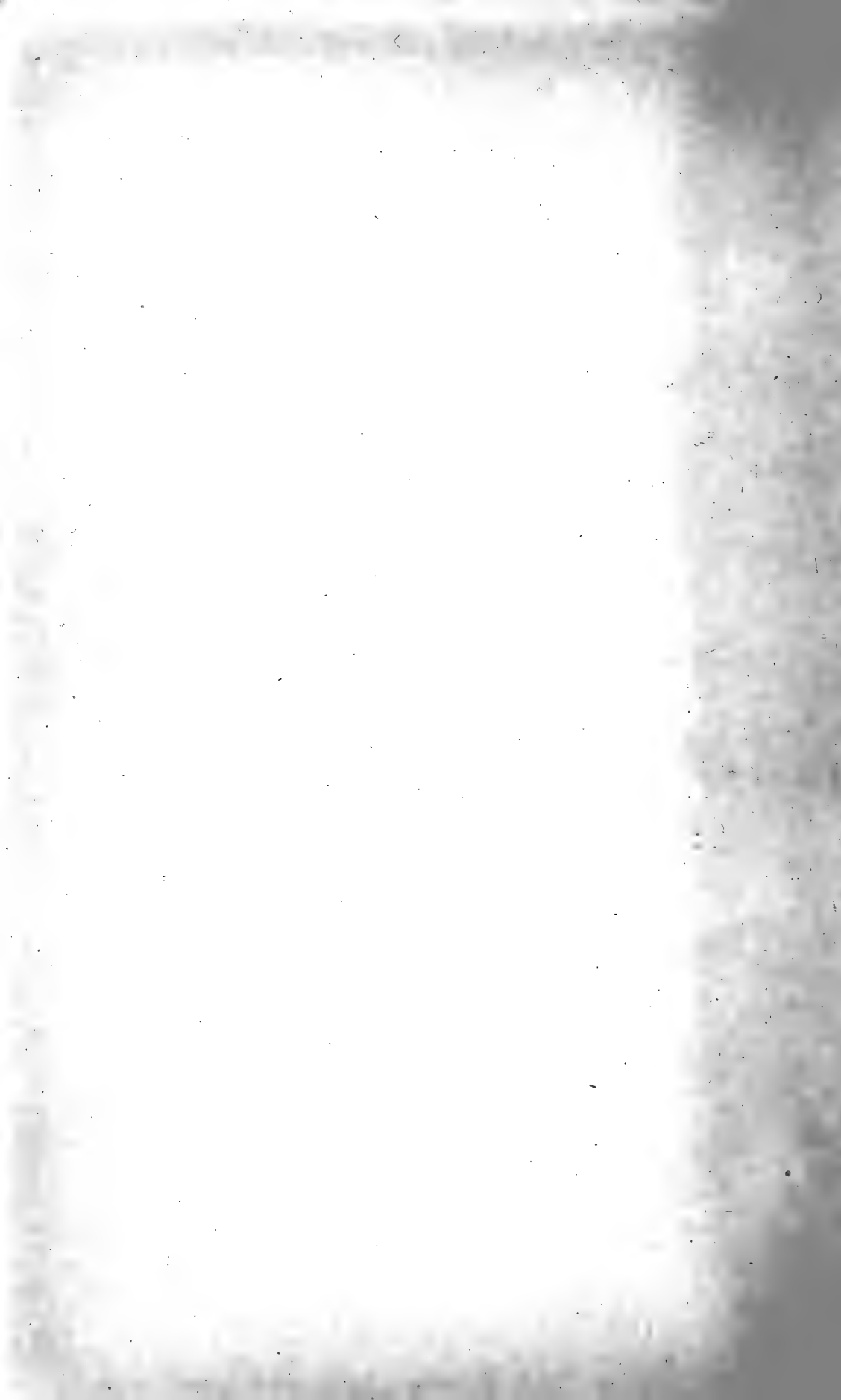

numerable avenues for the entry of mosquitoes. To enumerate a few of these: cracks and knot holes in the floor; ill-fitting doors; spaces between a corrugated iron roof and the plate left uncalked; cracks in the siding of an unsealed frame building; open spaces around plumbing, stove pipe, etc. In the Canal Zone, with the extreme variation in humidity between the dry and wet seasons, defects develop constantly in the woodwork of the light frame constructions employed. The screening is also exposed to rather severe strain. To maintain efficiently the mosquito-proofing of the dwellings, a weekly inspection was made of all the screened houses, and the needed repairs noted, and made at once. Since 1908 the repairing of screening has been delegated to the Quartermaster's Department for administrative reasons. From the standpoint of sanitation, it is wiser to maintain a screen-repairing force under the immediate control of the sanitary authorities, to insure this important work being done by a force specially trained to detect defects in mosquito-proofing, and to render dwellings mosquito-proof unhampered by the interference of other duties. After experience with both systems, the writers earnestly recommend that all questions of mosquito-proofing should be entrusted to the sanitary

206 The Control of Mosquitoes

authorities, who are more competent to judge the importance of the defects deemed unworthy of attention by the average layman, builder, and architect.

In a malarious locality the screening of dwellings is a necessity. With a view to determining as nearly as possible the difference in malaria infection between the inhabitants of screened and unscreened dwellings at Gatun, a study was made by Dr. Orenstein. The conclusions reached were that screened dwellings reduce the malaria incidence by at least one third.

It is almost certain that the protection afforded is greater than this study showed, for the reason that while the people residing in the screened quarters of Gatun were obliged to consult a government physician when incapacitated for duty by illness, the residents of the unscreened section were not required to adhere to this rule, and consequently there is no record of a probably large number of cases from these houses.

INFORMATION CONCERNING METALLIC MOSQUITO SCREENING

16 mesh copper alloy gauze will permit the passage of *Aedes calopus* only under stress of circumstances.



Types of screened houses: Culebra

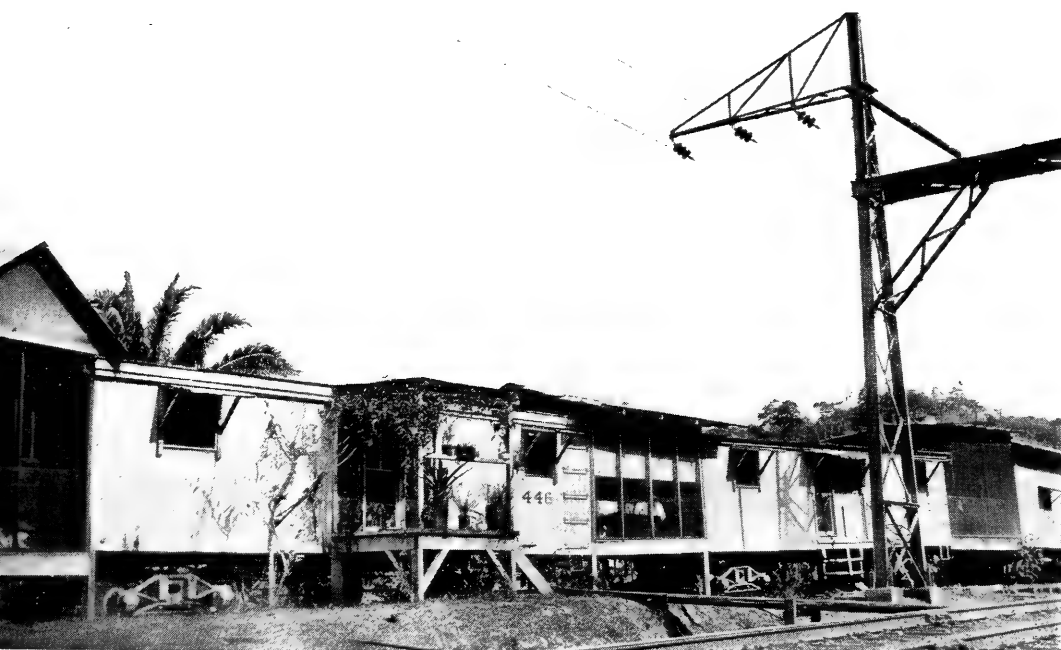

Screened cars in railroad construction camps



17 mesh and 18 mesh will exclude this species.

16 mesh will exclude *Anopheles*.

16 mesh—Area of aperture 0.00235 square inch.

Wire No. 28 B. W. G.—Diameter 0.014 inch.

Weight per square foot 0.2224 lb.

It is twice as strong as 18 mesh.

60.16% of open space.

95% increase in area over No. 31 B. W. G.

17 mesh—Area of aperture 0.00219 square inch.

Wire No. 30 B. W. G.—Diameter 0.012 inch.

Weight per square foot 0.17339 lb.

It is 50% stronger than 18 mesh.

63% of open space.

43% increase in area over No. 31 B. W. G.

18 mesh—Area of aperture 0.00208 square inch.

Wire No. 31 B. W. G.—Diameter 0.01 inch.

Weight per square foot 0.12835 lb.

67.39% of open space.

All copper alloy used in screening should contain not less than ninety per cent. copper and less than one half of one per cent. of iron.

DESTRUCTION OF ADULT ANOPHELES

In addition to the screening, a further decrease in the possibility of infected mosquitoes transmitting malaria can be accomplished by daily destroying

the *Anopheles* found in the dwellings. This has been systematically carried out in all the barracks in the Canal Zone, and is considered a very valuable measure when painstaking men are employed. Systematic mosquito catching in dwellings as a prophylactic measure against malaria originated in the Canal Zone. Briefly, it was the adaptation to sanitary purposes of the method employed by the entomologist in securing specimens. It was first tried in 1908 by W. R. Proctor, sanitary inspector, in a temporary camp known as Cocoli. This camp was in close proximity to extensive *Anopheles* breeding areas. Because of the camp's temporary character, more thorough methods of eradication were not used. Malaria soon developed among the laborers in the camp, and the incidence of this disease became very high.

Although there was much doubt concerning the efficacy of mosquito catching as a means of reducing the malaria incidence, it was tried as other measures could not be applied. To the surprise of all, the systematic destruction in the camp speedily reduced the malaria incidence. The catching was done at sunrise and sunset, by a negro laborer.

Mosquito catching in dwellings was then adopted as one of the regular prophylactic measures.

Screening and Destruction 209

During 1909 a number of camps were located along the new line of the Panama Railroad, officially known as the Panama Railroad Relocation. This is to be the permanent railroad after the Canal is completed. Four of these camps,

| Months. | 1909. | | 1910. | | 1911. | | Remarks. |
|-----------------|----------------------------------|-----------------|----------------------------------|-----------------|----------------------------------|-----------------|---------------|
| | Con- struc- tion Camps. | Entire Zone. | Con- struc- tion Camps. | Entire Zone. | Con- struc- tion Camps. | Entire Zone. | |
| January..... | | | 1.55% | .96% | .67% | .72% | Dry Season. |
| February..... | | | .67% | .71% | .42% | .77% | Dry Season. |
| March..... | | | 1.44% | 1.04% | .28% | .85% | Dry Season. |
| April..... | | | 2.50% | .81% | .56% | .68% | Dry Season. |
| May..... | | | 2.30% | 1.16% | 1.94% | 1.91% | Rainy Season. |
| June..... | | | 2.41% | 2.42% | 5.06% | 3.59% | Rainy Season. |
| July..... | | | 3.29% | 3.39% | 2.84% | 4.14% | Rainy Season. |
| August..... | | | 1.34% | 2.81% | 1.36% | 1.82% | Rainy Season. |
| September..... | | | .96% | 1.76% | 2.64% | 1.40% | Rainy Season. |
| October..... | | | 2.59% | 1.25% | 2.58% | 1.00% | Rainy Season. |
| November..... | | | .50% | 1.16% | 2.58% | .82% | Rainy Season. |
| December..... | .94% | 1.50% | .77% | 1.16% | 1.21% | .76% | Rainy Season. |
| Averagepermonth | .94% | 1.50% | 1.53% | 1.55% | 1.84% | 1.54% | |

Table of malaria incidence at construction camp.

with an aggregate population of about 1200, were located along twelve miles of the road, at intervals of three to four miles.

It would have been costly to attempt drainage and oiling operations of sufficient magnitude to protect all these camps from malaria, and it was decided to house the employees in screened cars, and to carry out daily mosquito catching in all of

them. The number of *Anopheles* caught in the cars, which were surrounded by mosquito breeding places, reached 1800 a week. The malaria incidence in these camps was but slightly above the incidence for the Canal Zone shown in the table. It will be observed that in 1910 the malaria incidence was two one hundredths of one per cent. less for the camps, and in 1911, three tenths of one per cent. more, as gauged by admissions to the hospital. It must be remembered, however, that the percentages for the whole Zone are based on the final diagnoses made by the examining physician. Experience has shown that the examining physicians sometimes give a provisional diagnosis of malaria in a somewhat larger number of cases than the final diagnosis sustains.

Another instance of the application of this prophylactic measure under more favorable conditions occurred near Corazal. In this case the camps were remote from native habitations. In June, 1908, several hundred United States marines were quartered for two months on Diablo Hill. During that period the malaria incidence among them averaged fourteen per cent. a week. No mosquito catching was done. Some cars in which railroad laborers lived were located at the foot of the same hill. From the early part of May to

the end of November, in the rainy season, when malaria incidence is high on the Isthmus, only four cases of malaria occurred among the forty laborers occupying these cars—a weekly incidence of three tenths of one per cent. The difference was due to having a man devote half an hour a day to the destruction of the *Anopheles* found in these cars. The work cost five cents a day.

The technic of hand catching is as follows: A glass tube about four and one half inches long and one inch in diameter, of the variety used for packing small camel hair brushes, is used. An inch layer of small rubber bands is packed into the bottom of the tube. They are held in place by a plug of absorbent cotton, which in turn is covered by a disk of blotting paper to facilitate the removal of mosquitoes from the tube, by preventing their entanglement in the cotton. A few cubic centimeters of chloroform are poured into the tube, which is then covered, and the chloroform allowed to become absorbed by the rubber bands. A tube thus prepared will be lethal to mosquitoes for several days. The chloroform tube has the advantage of being safer than the cyanide tube in the hands of a more or less careless laborer. To catch a mosquito with the tube, the cork is removed, and the mouth of the tube quickly placed

212 The Control of Mosquitoes

over the mosquito while it is at rest on some object. In a few moments the mosquito drops to the bottom of the tube.

Equipped with one of these tubes, a "slapper" made of a six-inch square of wire gauze fastened

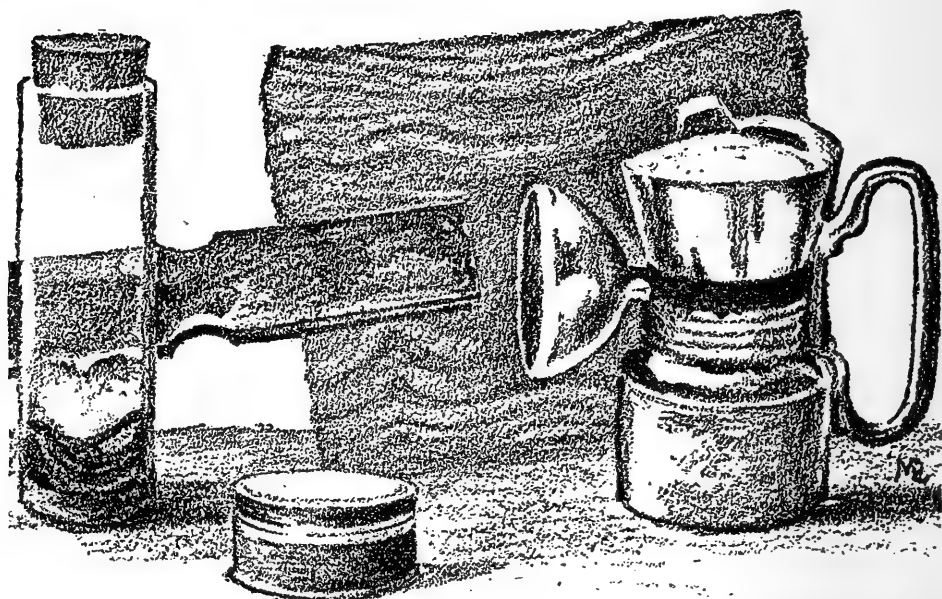

Slapper, chloroform tube, acetylene lamp, and pill box; used in catching *Anopheles* in houses.

to a two-foot stick, and, if necessary, a bright search-lamp or portable electric light and cord, an ordinary laborer will soon learn to catch a surprising number of mosquitoes. That mosquito catching in dwellings may be facilitated, preferably white or light colored walls should be insisted upon. *Anopheles* rest during the day in the

darkest nooks in the room; in remote dark corners, behind various objects on the wall, and under window ledges, etc. Careful search is required to find them and on a dark colored wall they are almost invisible.

In the early morning hours soon after daybreak, and in the twilight hour of the evening, *Anopheles* usually collect on the screening of verandas, doors, and windows, and are more easily caught than when indoors. The chloroform tube does not work very well on screening and the "slapper" is employed.

The cost of mosquito catching in dwellings is very slight. We employed common laborers at ten cents an hour. One man can cover a score of barracks in two or three hours. If the houses are in a group, an experienced mosquito catcher will examine as many as twenty in three hours. Of course, the number of houses covered depends on their size, the number and interior arrangements of the rooms, the number of mosquitoes found, and the distance from one house to another. The statement made above regarding the number of houses a man can examine, refers to the standard barrack of the Canal Zone, a one-room, one-story building about forty by sixty feet.

In the early part of 1911 hand catching was

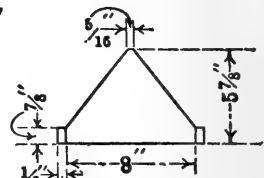
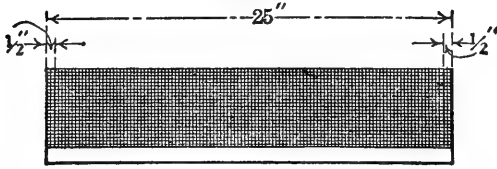
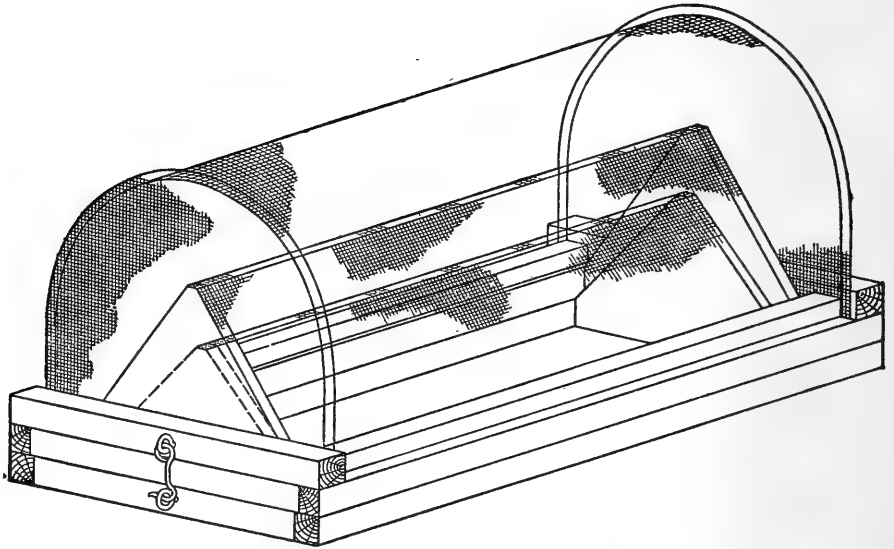

Wire Screen High Ridge
Frame of White Pine

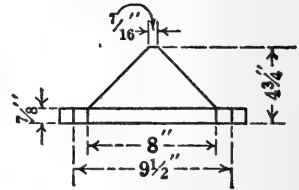
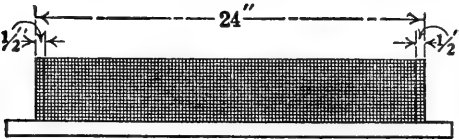
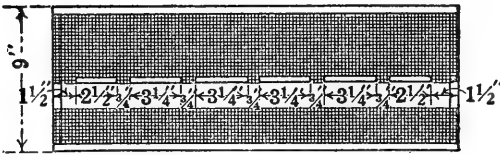

Wire Screen Low
Ridge
Frame of White
Pine

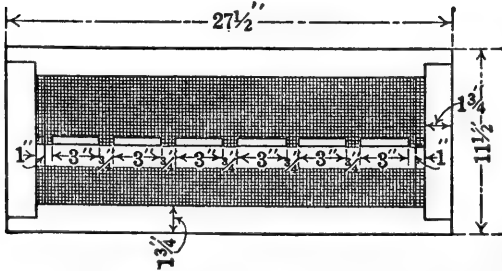

Mosquito trap, with details of construction.

supplemented by mosquito traps. The evolution

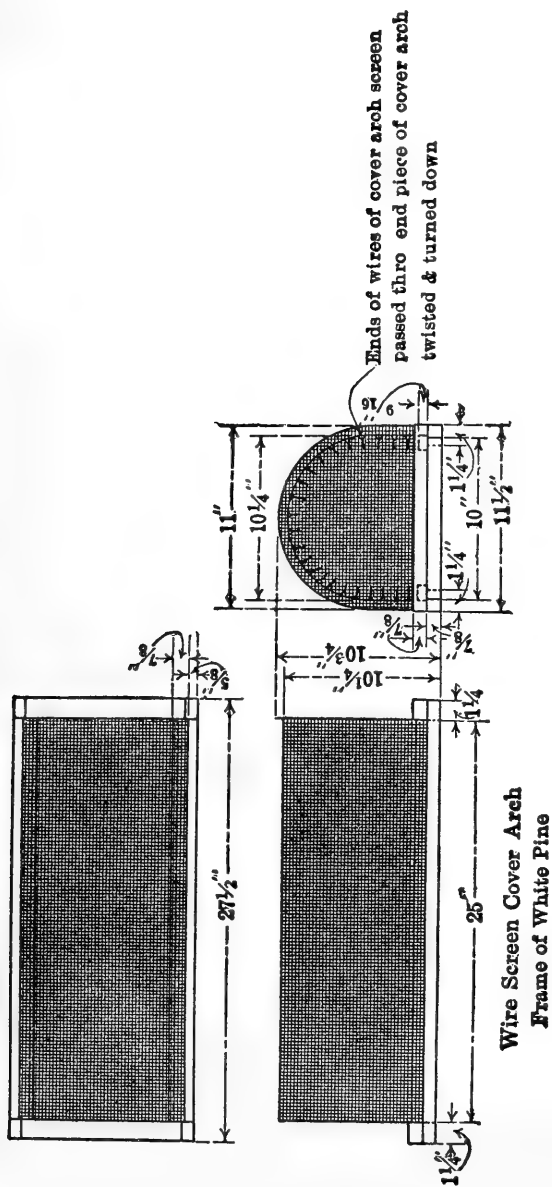

Mosquito trap, with details of construction.

of the mosquito trap into the model used at present has been gradual. The first trap constructed,

216 The Control of Mosquitoes

while ingenious, failed in its purpose—mosquitoes simply would not enter it. Gradually by developing the original ideas and plans of the senior author and by constant experimenting under his immediate direction, Messrs. Bath and Proctor, sanitary inspectors in the Canal Zone service, evolved the *Anopheles* trap now in use.

This trap is essentially a labyrinth built of wire gauze on a wooden framework. The illustrations on pages 214 clearly show its construction, and method of application to a screened window. As a mosquito catcher, the trap is of great service when properly used. It was found that in order to catch *Anopheles* the traps must be attached to the lee side of buildings, and that usually more *Culex* are caught if the trap is fastened on the windward side. The reason for this is yet to be determined, but the phenomenon is a fact, and should always be remembered when installing the traps. The possibility of some species of *Anopheles* being attracted by scent was considered. When two adjacent buildings were supplied with *Anopheles* traps, one inhabited and the other vacant, no *Anopheles* entered the traps attached to the vacant building.

It is found that more mosquitoes are caught when they are attempting to enter a building.



Interior of laborers' barracks, where *Anopheles* were caught daily

Therefore traps are installed with their openings turned outwards and are not used for collecting the *Anopheles* which have already gained access to the building.

Traps are of little use on unscreened houses and are never used on them.

The number of mosquitoes caught in these traps has been surprisingly large and it is not uncommon to catch several hundred per night in one trap.

In order to determine whether any mosquitoes escape, a trap in which a number of mosquitoes were confined was fastened to an empty trap. None passed from one trap to the other. If they could have found the openings in the trap in which they were confined they would have collected in the other trap.

Mosquito traps, built after the model used on the Canal Zone, are of distinct value as a prophylactic measure in anti-malaria campaigns, as an auxiliary to screening, and the destruction of mosquitoes by hand.

These mosquito traps cost about \$1.25 each when made by hand by the dozen.

CHAPTER XVI

THE RESULTS ACCOMPLISHED BY THE ANTI-MALARIA CAMPAIGN

THE methods of malaria control applied and developed on the Isthmus were put to a severe test and gave successful results. The topography, meteorological conditions, and constant changes due to the construction work, together with the character and constant moving of the population and their dwellings, and social conditions, were peculiarly unfavorable to the control work undertaken. The natives and employees, infected or well, were at liberty to live where and how they chose. We had no control over their movements or methods of living.

The area covered by anti-malarial operations was about fifty square miles, with a shifting population of many nationalities. It is now evident that even under such adverse conditions, malaria in the tropics may be kept down to a minimum rate without prohibitive cost.

Much valuable experience has been gained, that will aid future anti-malarial campaigns, and these newly devised methods of procedure and the important discoveries made as the work progressed will now make it possible for many sections of the tropics to develop their agricultural and natural resources.

Until now *Aedes calopus* and a few species of *Anopheles* have prevented the Caucasian race from settling and developing the tropics. In some of the richest parts of the United States more than fifty per cent. of the agricultural population is infected with malaria. In some parts of the tropics the malaria rate exceeds seventy-five per cent. of the rural population, and the transmission of infection often continues throughout the year. Under such conditions can progress or social development be expected?

In South America there are parts of the sea-coast, and even cities, to which laborers from the hill-country cannot be induced to go. They refuse a high rate of wage, and their reasons and judgment are sound. In recent railroad construction in Brazil, European laborers would not remain in the company's employ although paid an exceedingly high rate of wage. Where eighty per cent. of the laboring force is

220 The Control of Mosquitoes

sick at the same time their actual earnings are small.

The rich lands in malarial sections of the tropics cannot be economically developed without systematic malaria control. It is no longer a question of whether a corporation can afford to pay for the necessary anti-malaria measures; it is now admitted to be foolish to attempt development without reasonable sanitary precautions.

The preventive measures taken in the Canal Zone cost less than one cent a day for each person.

During the reconstruction of the Panama Railroad, in many camps we housed laboring forces in outfit-cars surrounded by extensive swamps, where drainage or economic control of mosquito life was impossible. By screening the cars, and destroying *Anopheles* in them once a day, the infection of laborers was prevented. Live mosquitoes caught daily in the cars were examined for parasites, but no infected specimen could be found. These preventive measures had not been attempted before, but can be applied again, and the efficiency of our troops on the Isthmus, and elsewhere, may be kept up to the standard.

Large forces of men employed in commercial enterprises may now be kept in good health where

sickness formerly made their day's work uncertain.

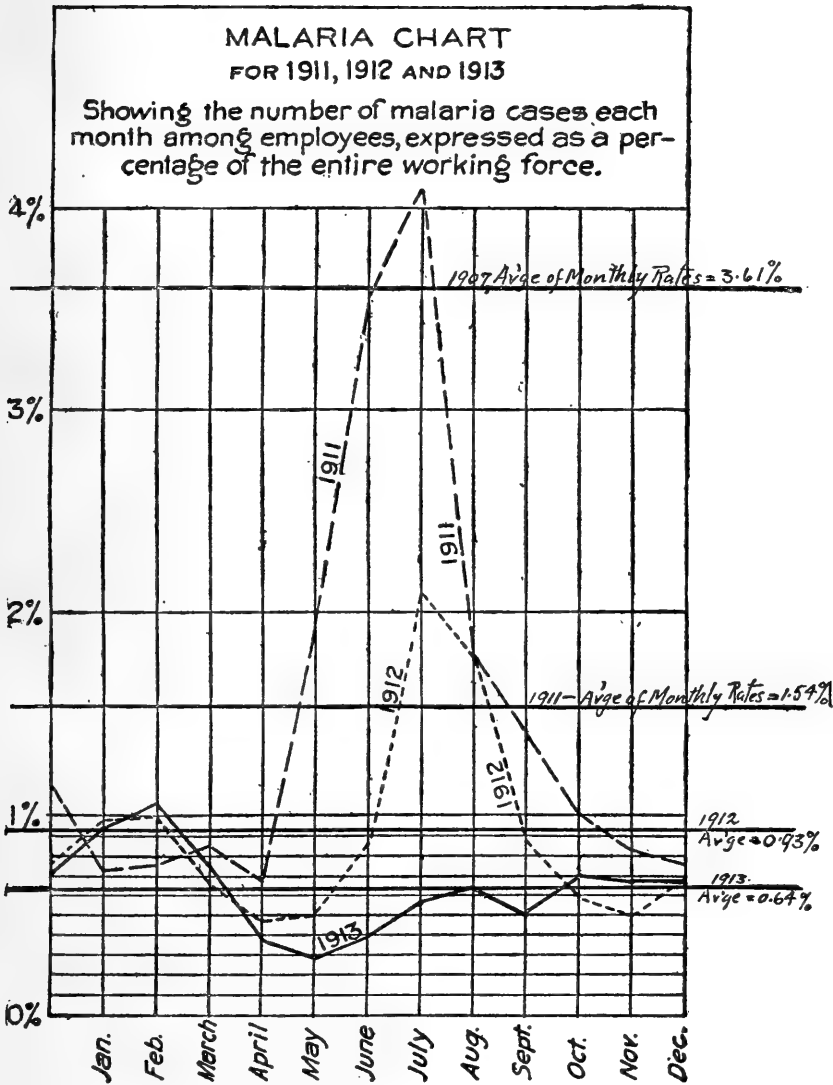

The item of high labor cost, because of malaria, has been a controlling factor in preventing progress in the South.

It has been ascertained that marked differences exist in the habits and life history of different *Anopheles*, and between *Anopheles* and other mosquitoes. We learned how to observe their flight, and that the malaria-carrying species can be stained, and by this means it can be determined how far and in what direction they travel; and by intercepting them in the path of their flight, they are made to register its general direction. It was established that some species of *Anopheles* travel farther than others.

It was observed that while *Culex*, and possibly other mosquitoes, enter a residence on the windward side, Isthmian *Anopheles* seldom do this. The importance of placing screened entrances and verandas on the windward side is now understood, but had not previously been considered. A method of making *Anopheles* trap and destroy themselves has been perfected; and it has been determined that some species avoid bright artificial light.

New methods of collecting specimens have been devised.

The migration of one species across the Isthmus was closely observed. Previously it was thought that malaria increased in proportion to the number of *Anopheles* in a malaria-infested community,

but Isthmian observations show several instances to the contrary. Where *Anopheles tarsimaculata* and *Anopheles albimanus* traveled long distances from the breeding to the feeding grounds their number at the settlements greatly increased, but the malaria rate did not rise. It is of great importance to know if these facts hold true in regard to other malaria-conveying species, as such facts determine the right areas for malaria control operations.

Due to factors not fully ascertained the same species do not always fly long distances, or even a quarter of a mile, to reach a house or village. Since learning how to observe and follow a flight we can now decide correctly which location to drain or treat for the protection of a town or settlement, and leave out the unessential.

The varying distance of mosquito flights of which so much, assumed and untrue, has been said and written, no longer appears impossible to solve. At present the important point to decide is the length of flight of different species of *Anopheles* in so far as it affects malaria transmission, and this may differ from the flight length probably essential for the propagation of the species.

The decidedly brackish marshes and the edges of shallow tidal flats, which were once the chief

sources of *Anopheles* at Gatun, Christobal, and Colon, presented conditions that may not be limited to the tropics, and afford precedents for future anti-malarial work near seacoasts farther north.

Although the *Anopheles* is usually considered a night-biting mosquito, Isthmian observation has proved that some species bite people in the daytime, both in houses and in forest shade; and when very numerous these insects appear less afraid of capture or exposure to natural light. In one instance *Anopheles tarsimaculata* and *Anopheles albimanus* bit freely all day in the sunlight, but this was the sole exception noted during more than twelve years of observation.

Other new facts of importance ascertained and improvements devised relating to control measures that resulted in reducing the cost and increasing the efficiency of anti-malaria work were:

Concentrated larvacide, effective when and where oiling is useless, is now made and transported economically.

Practical tests were made to discover the cause of the decay of copper alloy screening. It was found that monel metal mosquito wire, sixteen or eighteen mesh, remains intact after the best grade of copper bronze wire has decayed.

Devices for making wire screening continuously effective, together with systematic inspection and repair.

The complete eradication of mosquito-producing conditions in hillside ditches and the elimination of maintenance costs by the introduction of a thin reinforced concrete lining of special design.

The elimination of seepage water breeding areas by the use of special methods designed to suit local conditions, where standard methods of sub-surface drainage were valueless.

The use of automatic oil drips to control mosquito breeding in running water in streams and ditches, and that of oil-soaked waste for small see page outcrops.

In describing the use of oil on the Isthmus Dr. Malcom Watson, who has had extensive experience in measures for malaria eradication, and directed the successful control of malaria in the Federated Malay States, after inspecting the methods used at Panama, reported to the Royal Colonial Institute as follows:

As the greatest sanitary achievement the world has seen, it has a lesson for us. I went there because I wanted to study the details of their methods, in particular how much of their excellent results was due to drainage, and how much to screening, oiling,

226 The Control of Mosquitoes

and quinine. From my visit I concluded the results were mainly from oiling, which was done for practically half a mile on each side of the canal, or at least the inhabited portions of the Zone. The great majority of the population do not live in screened houses and very few take quinine. Drainage is constantly interfered with, and there is no agriculture. Colonel Gorgas had therefore everything against him except the determination to win and money to back him. Depending on oiling the organization has to be, and is, perfect, for failure for a single week would allow mosquitoes to develop. Their position is as if they had a wild beast by the throat, but were not allowed to kill it; yet if for a moment their grip were to be released, the beast would be on them. No greater sanitary work has been done: I doubt if we will see as great again. It is perfect work, and its organization is the only kind that would have succeeded under the circumstances. Some of the methods I saw are already being put into action in the Federated Malay States on my advice.

The health officials had no control over the selection of camp sites, yet were expected to maintain the standard of good health of the laborers. In some cases the camps were placed near prolific *Anopheles* production areas, and no extra funds provided for their treatment. Similarly difficult problems and conditions were brought about by unnecessary obstructing of natural watercourses and flooding hundreds of acres of jungle near

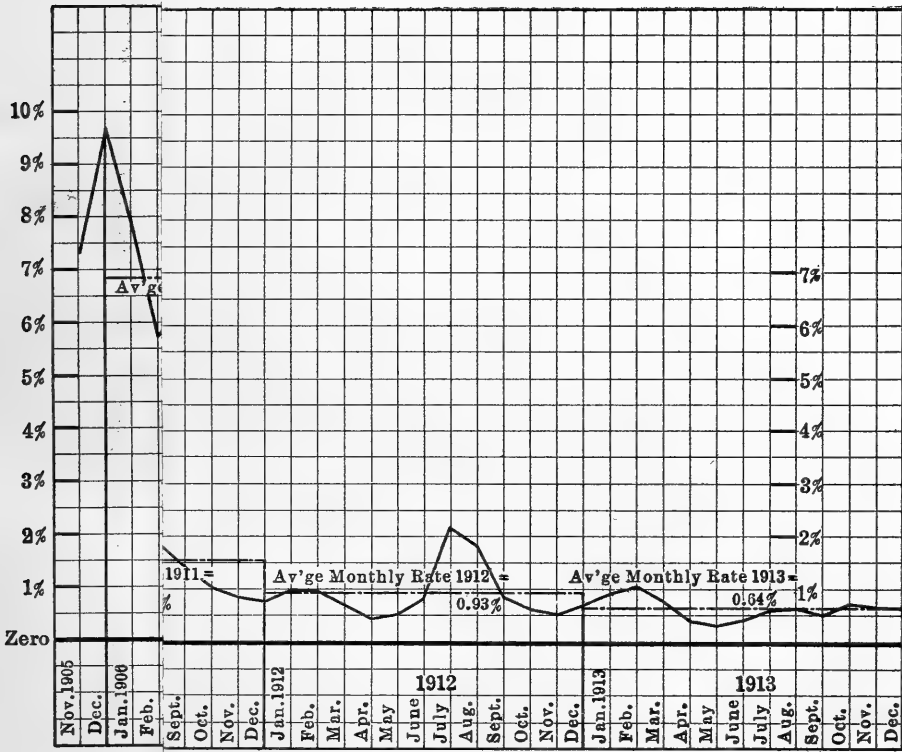

MALARIA IN THE CANAL ZONE; ISTHMUS OF PANAMA
Malaria cases among the employees of the Isthmian Canal Commission
[FROM NOV. 1905 TO 1913]

This Chart shows the number of Malaria cases, admitted to hospital each Month;
 expressed as a percentage of the entire working force

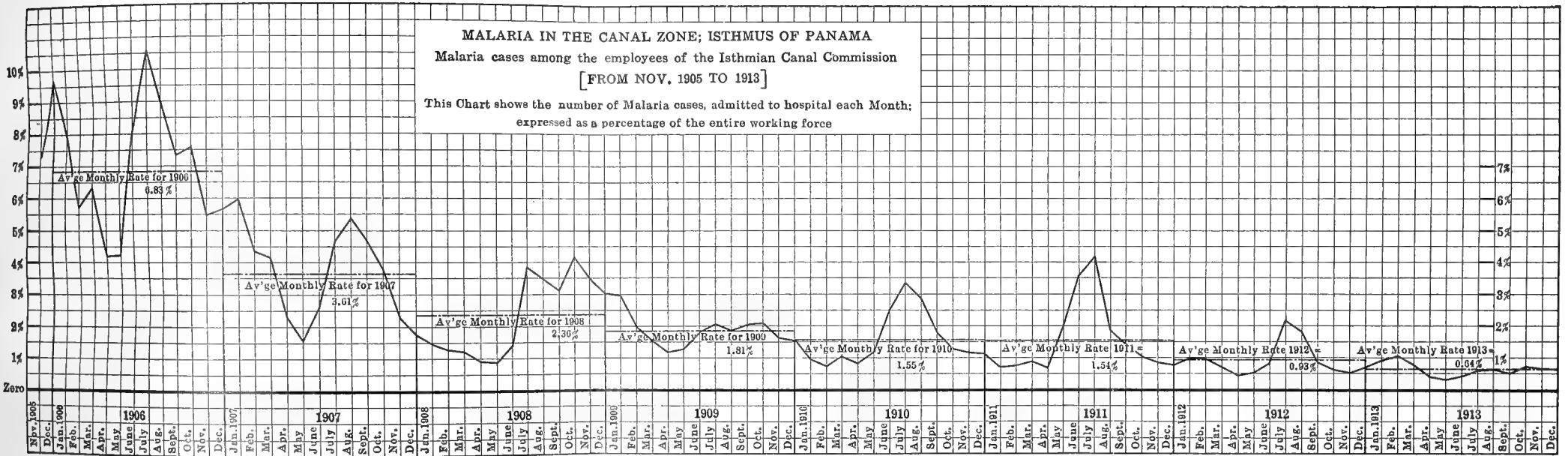

Malaria in the Canal Zone: Isthmus of Panama

1911

1912

1913

1914

1915

1916

1917

1918

1919

1920

1921

1922

1923

1924

1925

1926

1927

1928

1929

1930

1931

1932

1933

1934

1935

1936

1937

1938

1939

1940

1941

1942

1943

populated districts. Had the necessary topographical changes been considered or foreseen, the advantage of selecting other camp sites would have been obvious.

The proximity of proposed camp sites to extensive *Anopheles* producing areas, or native villages in which many cases of malaria exist, merits careful consideration.

The old idea of locating a house on a small hill to escape "malaria miasma" is of little importance. The slight advantage gained is only that of increased air motion causing temporary protection from mosquitoes.

The selection of poor locations for camps, and the creation of new and extensive *Anopheles* production due to topographical changes, and other causes, produced fluctuations in the malaria sick rate, many of which might have been avoided.

By studying each problem separately and devising methods to solve it, and concentrating effort on the most important points of attack in order to obtain the largest net returns for each dollar expended, we were able to reduce, from year to year, the malaria sick rate of the force employed.

The malaria charts show the results accomplished.

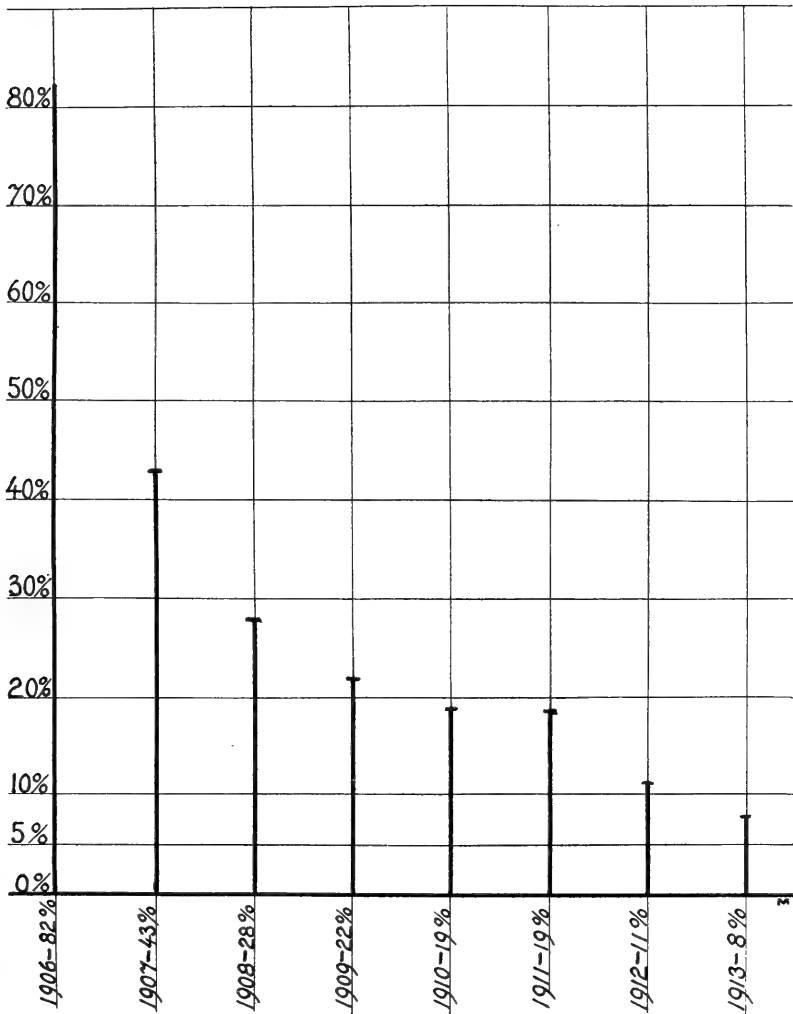

HOSPITAL CASES OF MALARIA AMONG EMPLOYEES-1906-1913
Compiled by adding monthly percentages of force sick with malaria.

PART II

The Yellow Fever Campaign

CHAPTER I

THE CAMPAIGN IN HAVANA

THE measures adopted to eradicate yellow fever from the Isthmus were based upon the knowledge gained from the work done by Colonel Gorgas and his associates in the eradication of yellow fever in Havana, Cuba. Havana was the first place in which anti-yellow fever measures were carried out with success, working along lines suggested by the theory of Carlos Finlay, and observations of H. R. Carter, which greatly aided and were confirmed by the experiments of Reed, Carroll, Lazear, and Agramonte, that the *Stegomyia fasciata*, now known as the *Aedes (Stegomyia) calopus*, was the only transmitting agent of this disease.

In order that the methods adopted in Havana may be better understood, it may be advisable to review the status of the knowledge regarding the transmission of yellow fever at the time the work of its eradication was inaugurated in Havana,

232 The Control of Mosquitoes

under the direction of Colonel Gorgas, in February, 1901.

Colonel Gorgas has treated this subject so comprehensively in his final report to General Leonard Wood that we quote from it:

For over 200 years this disease had, at short intervals, devastated the Atlantic and Gulf coasts of the United States, causing great loss of life, and still greater financial loss, due to the entire cessation of commerce which occurred during the epidemic of 1878, which affected particularly the lower Mississippi Valley, amounted to \$100,000,000, and in years when there was no epidemic, quarantines had to be kept up against the infected regions around the Gulf of Mexico, which stopped almost all travel and greatly interfered with commerce. The United States had come to look upon Havana as the particular point from which infection was spread. Yellow fever had been continually present in this city since 1762. Every month in every year during that time there have been some cases. In all other localities of North America where yellow fever occurred, it occurred epidemically; that is, the locality was free from the disease for a longer or shorter time. In places above the frost line, winter always puts an end to the disease, and in localities in the tropics it always terminates after a greater or lesser period of years from the exhaustion of the non-immune material.

Briefly stated, on February 1, 1901, the date of the commencement of anti-yellow fever work

based upon the theory of mosquito transmission, the following facts were known concerning the method of the transmission of this disease, and concerning the transmitting agent, the *Stegomyia* (*Aedes*) *calopus*, then known as *Culex fasciatus* (Fabricius):

The Army Medical Board had proven:

1. That yellow fever is capable of being transmitted by the female of the mosquito now known as the *Aedes* (*Stegomyia*) *calopus*.

2. That this mosquito must have previously fed on the blood of an individual sick with yellow fever, within the first three days of the disease.

3. That an interval of twelve days or more, after feeding on a yellow fever patient, is necessary before the infected mosquito is capable of conveying the infection.

4. That yellow fever can be produced by the subcutaneous injection of the blood of a yellow fever patient, taken in the first and second days of the disease.

5. That the period of incubation of the disease is between forty-one hours and five days and seventeen hours.

6. That "fomites" cannot convey the disease.

7. That the *Stegomyia fasciata* (*Stegomyia*

calopus; *Aedes calopus*) is a house-haunting mosquito. *Its breeding habits, however, were not known.*

After the conclusions of the Army Medical Board were made known, the next problem of importance was the application of this knowledge to the best advantage. Whether it would be possible to eradicate, or reduce to a non-infective minimum, the *Stegomyia calopus* was then not known, and did not appear practicable. It was noted that the *Aedes calopus* entered and left buildings, and that its larvæ were mostly found out of doors. It was generally thought that it oviposited in the open, under conditions similar to those suitable for various other species of *Culicidæ*; and that it could fly long distances to reach habitations. The limits of its flight were not known. It had been observed that some *Culicidæ* travel with air currents, and it was supposed by many that the *Aedes calopus* did likewise; there being no evidence to the contrary.

These theories brought into the project of eradicating the *Aedes calopus* the question of drainage or filling of all the tidal and swampy land near Havana Bay, a very extensive area.

Further investigation and research was carried on to determine the possibilities of immunizing the non-immune or foreign population, by subject-

ing them to the bites of infected *Aedes calopus*, in the hope of producing mild attacks of yellow fever, and thus conferring immunity. It was soon found, however, that the severity of the attack could not be controlled, and this work was abandoned.

The board of army surgeons who verified Dr. Carlos Finlay's theory of the transmission of yellow fever by the mosquito, and made use of Dr. H. R. Carter's observations on time of incubation, had no opportunity to study the natural life history or the possibilities of controlling the *Aedes calopus*; it was therefore natural that they did not suggest the methods of procedure needful for yellow fever control.

Colonel Gorgas decided to ascertain at once the possibility of *Aedes calopus* destruction on a large scale throughout the city, to determine what could be accomplished along this line. Work of this nature had not been attempted before, and all facts of importance relating to *Aedes calopus* destruction were collected as the work progressed. He believed that the propagation of this mosquito could be controlled, but few other people at that time believed as he did. It was the general opinion, with few exceptions, that an impossible task had been undertaken.

The possibilities of the use of oil for purposes

236 The Control of Mosquitoes

of mosquito destruction and control were discovered by Dr. L. O. Howard and published by him as early as 1892. This information was of great value to the American officials in Cuba and has since been used extensively in many other parts of the world. In 1892 he published an article in *Insect Life* on the use of kerosene against mosquito larvæ; in 1896 in Bulletin No. 4, Bureau of Entomology, Washington, D. C., several pages were devoted to the subject of remedial measures against mosquitoes; and again in 1900 in Bulletin No. 25, he published "Notes on Mosquitoes of the United States, Giving some Account of their Structure and Biology, with Remarks and Remedies." In the latter publication he summarized everything which had been done up to that time on the remedial question.

The first systematic work of mosquito destruction in Havana was started on March 27, 1901. Before this time a considerable number of adult mosquitoes had been destroyed by fumigation directed against fomites. Operations were at first confined to the area lying between Monserrate Street and Havana Bay (see map). This portion of the city was known as the yellow fever district. In this district were the commercial houses, and the hotels and boarding-houses the immigrants

1111



MAP OF THE CITY OF HAVANA

AUGUST 1ST 1899.

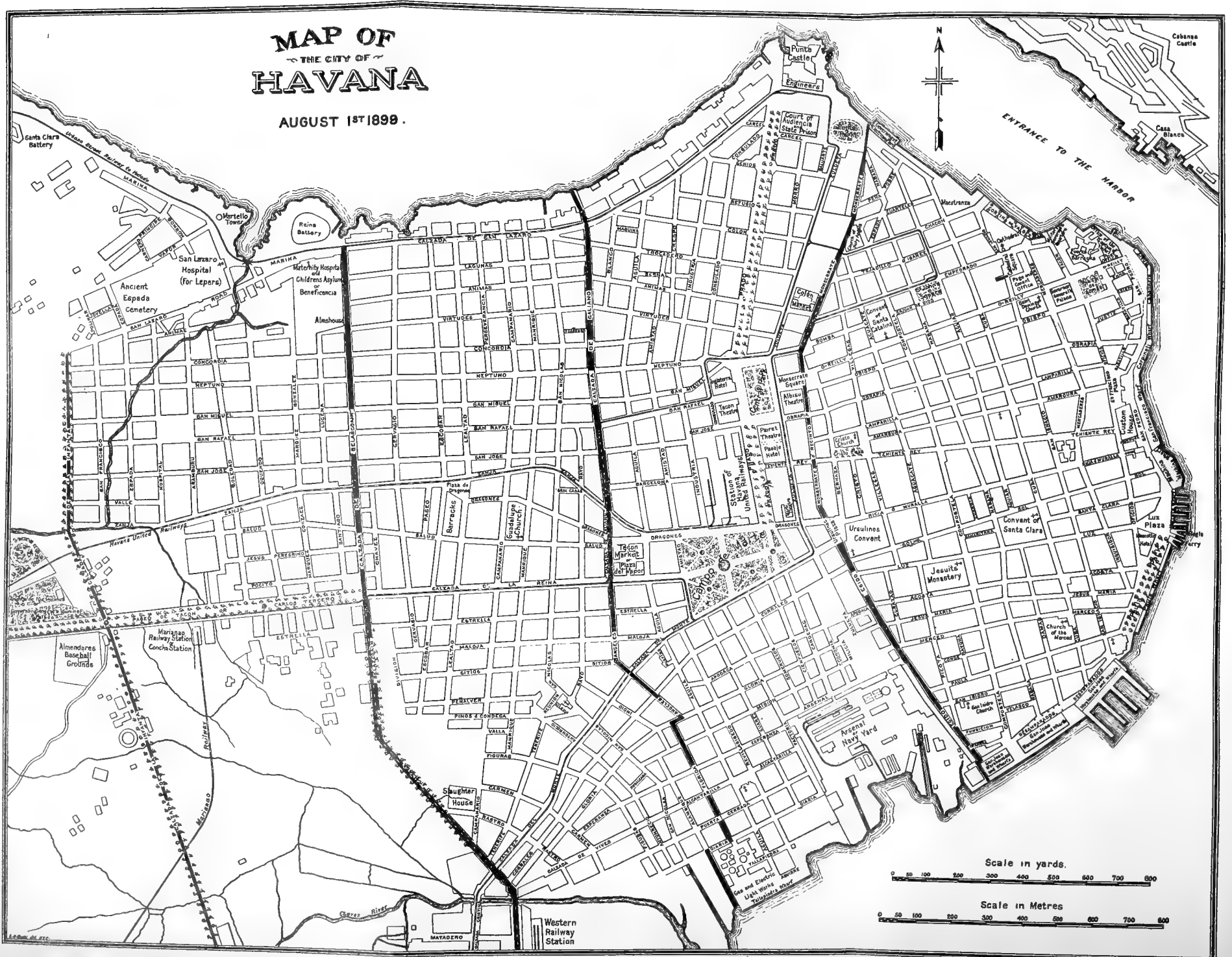

Map of Havana: Showing the yellow fever district



occupied while looking for employment. It is the custom in Havana for clerks and employees to live and sleep in the stores or establishments where they are employed. This arrangement helped to make a concentration of non-immunes, and hence the yellow fever cases in the locality mentioned.

In the preliminary mosquito destruction campaign one inspector and two oilers were employed to visit all houses and yards, and to destroy all mosquito-producing containers. The length of time necessary for the thorough inspection of the district above mentioned was soon determined, and it was then divided into sections, of such sizes that one inspector and two oilers could destroy or control any mosquito breeding places in every house and yard in their section once a week. Later this system was extended throughout the entire city, which was divided into thirty districts. The first inspection of the city showed a total of 26,000 water containers with mosquito larvæ. Most of these were producing *Aedes calopus*, which were very numerous in the residences.

The method of procedure was as follows: A list of all houses was kept at the main office. The district inspectors turned in each day a report of containers found, and an entry was made on

238 The Control of Mosquitoes

a card kept for each house, thus giving a history of the *Aedes calopus* producing status of every house in Havana.

The entire clerical work was accomplished by two men. Abbreviations were used to save time on reports: thus, "Real No. 3, 2B, 3T, 1Tna" recorded the fact that at No. 3 Real Street were two barrels, three tanks, and one *tinaja*, in which mosquito larvæ were found. Similar abbreviations were used for all classes of water containers.

The inspectors' report forms were designed to save time, and were arranged as follows:

District No. 5

| Date _____ | | | | | | | |
|------------|---|---|--------------|-------|-------|----------------------|----------------------|
| Street No. | B | T | Tna (Aljibe) | Latas | Pozos | Misc. | Name of House Tenant |
| Real | 1 | | | | | | Jose Gomez |
| " | 3 | 2 | 3 | 1 | | | Juan Perez |
| " | 5 | 1 | | | 1 | Eave trough | Rosa Mora |
| " | 7 | | | | | Ant Guards in Garden | Alez Rito |
| " | 9 | | 1 | | 1 | | Manuel Moreno |

_____(Inspector)

The reports were read at a glance, and rapidly transferred in the office to the house card showing the names of owner and tenant, with dates showing when mosquito larvæ were found, and in what class of containers. These reports were of great use, in showing progress made in *Aedes calopus* control and preventing the continuance of mosquito propagation, besides furnishing valid evidence in courts adjudging fines.

A system of checking the daily inspection was employed. Each day a trustworthy man made an independent inspection of several houses in every district, both before and following the visit of the district inspector. It was thus known to the office, beforehand, what the district inspector should find and report as well as whether several reports of the previous day's work were reasonably correct. In the early stages of the campaign this checking was very useful, and kept the inspectors up to the mark. Later, however, the inspectors worked more thoroughly, and the preinspections and reinspections seldom differed from the district inspectors' reports. In addition, the inspectors were transferred from one district to another at irregular intervals, and thus a check was obtained, and the force kept very much alive. The chief sanitary officer and his assistant made

frequent inspections, and kept in close touch with the daily work.

It will be readily seen that such a system made the possible mosquito producing water containers disappear speedily. The number of adult *Aedes calopus* in houses quickly decreased, and to this is attributed the rapid disappearance of yellow fever from Havana.

When the work of *Aedes calopus* destruction was commenced, it was not known how far they could travel or migrate, nor was it then known that they were exclusively container breeders. *Culex* with banded legs were seen at a distance from dwellings, and were reported as *Aedes calopus*. Little had been written concerning the habits and life history of mosquitoes up to that time, and it was vaguely supposed that all mosquitoes were more or less alike in their habits, and that all traveled long distances. It was not known that *Aedes calopus* do not breed in pools and puddles, or that the larvæ of this mosquito are never found far from houses, unless conveyed by man. As a matter of fact, we occasionally find a few larvæ in streams and ditches, but it was not known at that time that they had been washed out of containers.

As the larvæ destruction in houses and yards progressed, fewer adults were observed in dwell-

ings. The floors of all rooms were swept after each fumigation, and definite evidence obtained of the decrease in the number of *Aedes calopus*. Having definitely established the possibility of greatly reducing the number of these mosquitoes in Havana, it was easy to foresee that by continued reduction very few of them need exist in the city; and that it was within the bounds of possibility to eradicate them.

It was found that the tenement house districts, locally called *Casas de vicino*, were the most difficult to control. In these houses several families used in common a yard, or *patio*, in which their water-holding containers were placed. It frequently happened that the owner of a container holding mosquito larvæ preferred not to claim ownership through fear of arrest, and at times it was very difficult to prove who was the real owner.

At one time many tenants hid the red earthenware jars (*tinajas*) containing their day's water supply. The coming of the inspector was signalled along the street and the water containers disappeared as though by magic. It even became necessary to use a list of all water containers in some districts to avoid missing any having larvæ, and to save time during inspection.

The experimental work on the prophylactic

inoculation of yellow fever proved unsatisfactory, but fortunately at that time the destruction of *Aedes calopus* had progressed far enough to show what could be accomplished in a few months of effort and persistence.

The discovery that yellow fever propagation could be arrested by destroying, by fumigation, the *Aedes calopus* in the dwelling where the case occurred, and the houses immediately adjacent, showed that they do not fly long distances. This also indicated that even if these mosquitoes bred in the country, they did not find their way into the city in dangerous numbers. This discovery was very useful, as well as encouraging.

The scheme of the work being carried out was strongly supported by General Leonard Wood, military governor of Cuba, who had full confidence in the ability of the chief sanitary officer. The people of Havana, being mostly immune, took small interest in yellow fever eradication, but submitted with little objection to the enforcement of the sanitary regulations. They thought that the Americans did not know how to control the situation, and had seized upon something new to occupy their time and make a showing. There was more opposition, in proportion, from foreigners than from natives. It was most fortunate that

so little opposition interfered with the campaign, for it must be remembered that this was all pioneer work. There was much ridicule of our methods at that time, but fortunately this spirit of raillery and its pernicious influence in encouraging active and passive opposition to sanitary methods is now decreasing. Sanitarians need the interest and coöperation of the general public.

In July, 1901, while the sanitary department was busy with yellow fever in Havana, six cases were reported from Santiago de las Vegas late one afternoon. Before daylight on the following morning a complete sanitary brigade was on its way to that town. In six weeks yellow fever was eradicated, and it became exceedingly difficult to find *Aedes calopus* there.

At the instigation of Colonel Gorgas, a law was enacted, making it compulsory for physicians to report every case of yellow fever; and also all cases of fever, of whatever nature, occurring among foreigners. In locating yellow fever cases, the sanitary department also received assistance from the hospitals in Havana connected with the societies known as *Centros*.

The larger part of the foreign population is Spanish, mostly unmarried men. The majority join one of these *Centros*, each of which has a

244 The Control of Mosquitoes

well-equipped hospital, where the members receive medical and hospital treatment without extra cost above the annual dues. Because of this custom, the hospitals in Havana receive most of the sick Spaniards, and the detection of yellow fever cases was greatly facilitated. All American "yellow fever suspects," as well as yellow fever patients, were sent to Las Animas Hospital, then under the direction of the chief sanitary officer, and as a rule such cases were reported in the earlier stages. All cases were advised to take hospital treatment, and most of them did so. When a patient preferred to remain at his residence, it was allowed; his room was screened, and the screen door was kept locked and continuously guarded. Only persons authorized by the chief sanitary officer could enter. Non-immunes were not allowed in the patient's rooms under any circumstances. As soon as a "yellow fever suspect" was reported, he was conveyed to the hospital, or put in a screened room. Next, the history of his recent visits was traced, recorded, and verified as thoroughly as possible, in order to determine the source of his infection. Then his house and the adjacent houses were fumigated. When the patient preferred treatment at home, his room was not fumigated until he re-





CURVE LINE OF DEATHS BY YELLOW FEVER

CURVA DE MUERTES POR FIEBRE AMARILLA.

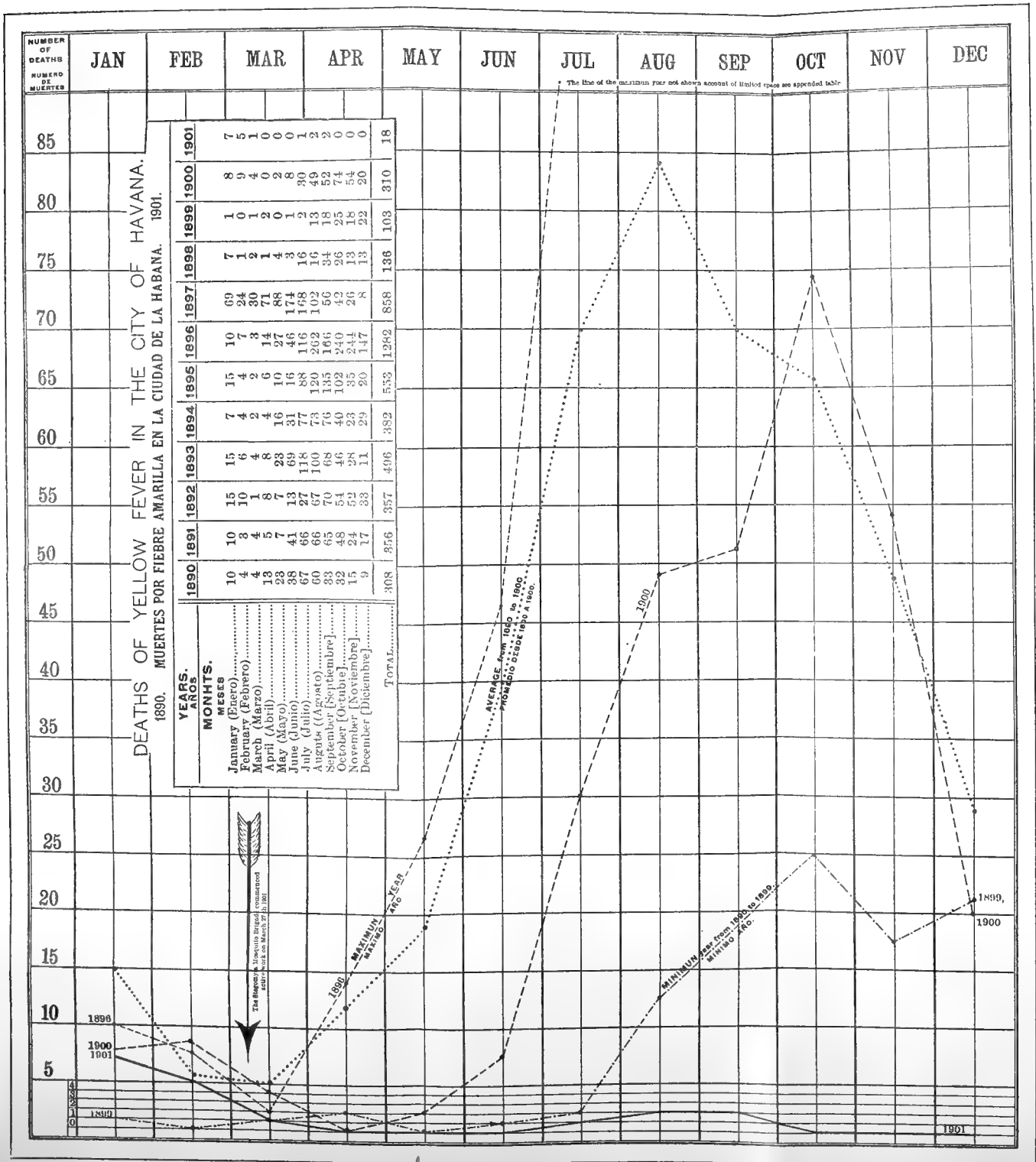

Chart showing prevalence of yellow fever in Havana, Cuba

covered, but all the other rooms were fumigated immediately, together with all places visited by him within a week before the onset of the disease and during three days following. Wherever he might possibly have been bitten, fumigation was ordered to destroy the mosquitoes which had infected him, or might have become infected by biting him. It was found important to investigate his history very thoroughly, and to verify and check all obtainable information. Sometimes the history proved inexact, and certain foci of the infected mosquitoes were left undestroyed. It may also be true that walking cases of yellow fever occurred, which would account for so-called sporadic outbreaks of yellow fever. As the campaign progressed, and the mosquitoes were slowly but surely reduced in number, these instances became of less importance.

The storehouse for all materials and apparatus necessary for fumigation operations on a large scale was established near the stables where the wagons and ambulances of the sanitary department were kept. The fumigation brigades, each consisting of a foreman and ten men, reported every morning for duty at the storehouse. In addition, each foreman knew where to find his men at any hour in case of emergencies, either during or after

246 The Control of Mosquitoes

working hours. Material was kept in such readiness that required quantities could be measured out and issued rapidly, and the brigades relied on for quick service at short notice. Time was also saved by transporting men and supplies in ambulances.

When a suspected case of yellow fever was reported, the yellow fever commission at once saw the case, and if fumigation was decided upon, the tenants were immediately notified of the proposed fumigation, verbally, and by written notice posted on the house, stating the time work would be started, and the probable time of completion. At the date and time arranged for, the fumigation brigade commenced operations. First, openings such as doors and windows were closed, to retain all mosquitoes within the building. As little disturbance as possible was made, in order that they should remain at rest in the rooms.

The doorway through which supplies had to pass, was kept closed as much of the time as circumstances would permit. One or two laborers were assigned to each room, to paste with paper strips all cracks, and other communications with the outside air, to make the room air-tight. Large openings were subdivided by wooden strips so arranged that single sheets of manilla paper would

reach from one piece to the other. On windy days a center support for each large sheet of paper was used. The paste was made of flour and water. Paper strips of different widths were kept in stock to expedite the work.

The cubic contents of each room was ascertained to determine the number of fumigation pans required.

Just before a room was finally closed, the pans containing the sulphur or pyrethrum were placed in position on the floor. Each pan was placed inside a larger shallow iron vessel containing water as a precaution against fire, in the event of the iron pan containing sulphur or pyrethrum breaking during the progress of the fumigation. Small boxes holding exactly one and two pounds of sulphur or pyrethrum powder were used for measuring, and it was the duty of the sanitary inspector in charge of the fumigation to supervise the placing of the fumigants in the pans, and the correct number of pans in each room. When as much of the sealing was accomplished as could be performed without closing the door, or other exit, the inspector arranged the fumigation pans in the most advantageous way, sprinkled the surface of the sulphur or pyrethrum powder with a small amount of wood alcohol, and then ignited the

fumigating material. After igniting the contents of the pans, the inspector remained in the room until he was sure that the fumigating powder was burning properly, and that the fires were not likely to go out before the fumigants were entirely consumed. A man was ready to paste up the exit the moment the inspector left the room. Room after room was treated in this manner, and hallways were treated last. The laborers engaged in pasting work remained at the doors long enough to detect escaping fumes, and repair defects in the sealing.

The amount of pasting varied with the nature of the building treated. In some cases the entire wall of a room had to be covered with paper. All ceilings or roofs, walls, and floors were carefully examined, and every opening closed. Each room was dealt with as a separate unit, to prevent the formation of air currents and the traveling of fumes to a possible avenue of escape. During the entire fumigation period in Havana absolutely nothing was burned by the fumigation operations, although wooden houses might easily have caught fire. Every precaution was taken against accident. It was always necessary to make sure that no cats or dogs were hiding in out-of-the-way places.

In well-built stone houses we used one pound of a

superior grade of pyrethrum powder per thousand cubic feet of air space. Sulphur, in the form of "flowers of sulphur," was used in the same proportion. Where a probable leakage of fumes was seen to be more or less unavoidable, the quantity of fumigants was increased proportionally, and the inspectors became quite expert in gauging the amount required; as a matter of fact, they usually erred on the side of safety.

In loosely built houses, the wind velocity had to be considered. Sometimes it was not advisable to paper the entire wall area of a house to prevent the leakage of fumes. Time was of value, and too much moving around of laborers and the manipulations incident to the papering might cause the mosquitoes to fly away, so that it became necessary to avoid any commotion that would result in sending out of doors the very infected mosquito the fumigation was intended to destroy.

After all the sulphur pans were burning, and the last door of the house was locked and sealed, a notice was posted upon it stating the hour of closing and that of reopening by the sanitary department, and also that any person, other than the inspector in charge, who opened the door would be guilty of a misdemeanor and treated accordingly. A laborer was detailed to watch

250 The Control of Mosquitoes

the house, and attend to any additional pasting that became necessary. When the fumigation period had elapsed (or after three hours), as many doors and windows as possible on the lower floor of the leeward side were first opened to let out the fumes. Those on the windward side were opened next. The inspector entered the building as soon as the fumes would permit, and inspected the pans, to see that none had been prematurely extinguished, and ascertain that the fumigation was entirely satisfactory. A repetition of fumigation was seldom necessary. Floors were then swept and mosquitoes carefully collected. These, although nearly always dead, were at once burned, to obviate danger from their revival.

We had established by experimental fumigation that apparently dead mosquitoes revived after several hours' exposure to the air.

Immediately on the return of tenants to their rooms, they were requested to examine their effects, and verify their good condition.

All traces of paper and paste were removed after each fumigation, by hot water and scrubbing brushes where necessary. Before the fumigators left a house, the inspector obtained a signed statement to the effect that no articles belonging to the tenants were missing. Great care was taken to

select honest laborers, and practically no thefts occurred. As soon as the brigade completed one fumigation, the next was started. Occasionally the removal of paper, cleaning up, etc., was delayed for a day or two and the men were employed at this work while other houses were closed during fumigation.

In Havana houses were being fumigated before February, 1901, and where pyrethrum was used at that time it was bought from local merchants. The results varied considerably. Sometimes the mosquitoes were killed, and at other times they were not. The quality of the pyrethrum varied greatly. Samples were obtained from the dealers, and tests made to determine the quality on which the quantity needed for a given volume of space depends.

A room at Las Animas Hospital was used for the fumigation tests. The cubic content was about 1500 cubic feet. A glass transom over the door served as an observation window to note the effect of fumes on mosquitoes subjected to fumigation. It so happened that house flies were in the room during the first series of tests, and after the killing of *Aedes calopus* it was noted that the flies still lived. The amount of pyrethrum per 1000 cubic feet was increased until it was sufficient to kill the

252 The Control of Mosquitoes

flies. When all flies were killed, no mosquitoes remained alive. An hour longer was required to kill flies. Cages containing both were hung near the windows, close to the glass, that they might be observed through the fumigation period, and it was realized that the pyrethrum on the local market varied so much in quality as to be useless for practical fumigation, and samples for experimental purposes were obtained from the United States.

On receiving a satisfactory quality of powder, larger quantities were purchased, with the privilege of rejection if there was variation in quality as to generation of fumes and culicidal powers. The contractors kept the quality up to standard, and good results on a large scale were obtained.

The experiments determined the fact that in a room with air-tight walls, floor, and ceiling, one pound of this particular grade of pyrethrum powder per thousand cubic feet and a three-hour exposure to the fumes was sufficient to kill all mosquitoes in the room. Subsequent experiments proved that with any possible chance of leakage of the fumes, the quantity of pyrethrum used must be increased to allow for the leakage. Where the room was not reasonably air-tight and the leakage was large, pyrethrum could not be relied upon, unless all walls, ceilings, roofs, etc., were covered

with paper to prevent the escape of the fumes. Where the leakage was extensive it was not effective.

In the experimental work it was observed that there were most dead mosquitoes per unit of area near the source of light. It was also noticed that before they were overcome by the fumes of pyrethrum many of them pulled off one or more of their legs, but that this did not occur when fumigating with sulphur, tobacco, or formaldehyde. Pyrethrum powder deteriorates rapidly when stored in a humid tropical atmosphere.

The proprietors of tobacco warehouses and shops objected to pyrethrum fumigation of their premises because of the odor, and experiments were made to determine the value of tobacco stems as a culicide for *Aedes calopus*. It was found that the results from its use were equal to sulphur, and the tobacco merchants reported no harmful effect or deterioration of value in the stored tobacco and tobacco products.

It was found that sulphur fumes injured all ordinary metals, unless they were protected by vaseline or some other greasy substance; and that it bleached and stained many fabrics, and stained certain painted surfaces. Pyrethrum only stained some materials slightly, but left an odor.

254 The Control of Mosquitoes

The results of experimental tests with the three substances, as obtained at Las Animas, were as follows:

Pyrethrum, burned at the rate of one pound per thousand cubic feet in layers not greater than one inch in thickness, destroyed all mosquitoes in a well sealed air-tight room within three hours.

Tobacco, at the rate of two pounds of stems (waste from Havana factories) per thousand cubic feet, if it all burned, killed them in three hours.

Sulphur, at the rate of one pound per thousand cubic feet, was effective with an exposure of three hours or less.

It is almost impossible to find a satisfactory grade of pyrethrum powder for fumigation purposes on the market at the present time.

In 1906 Kendall experimented with campho-phenique as a fumigant; his methods and conclusions are quoted:

This substance first used in the Gulf States, has been tried with great success here. Berry, experimenting with this mixture, found that a shallow pan placed upon a short piece of stove pipe formed a good apparatus for volatilizing the campho-phenique, and his method was tried here. The results were disappointing, and except for a fortunate trial of the fumes of this substance, they would have been discontinued. It was observed that the fumes killed

mosquitoes with great rapidity, and that the insects were actually dead, not merely stupified, as is the case with pyrethrum. With this observation as a basis, a piece of apparatus, which will be described in great detail later on, was evolved, which has given excellent results in our hands.

The apparatus was constructed with the idea of removing every possible source of danger which would occur with the mixture, as well as to provide for the fact that unskilled labor would have to be employed in practical fumigation. Cheapness is the first consideration, because it is frequently necessary to use large numbers of pots in fumigating large buildings. The use of galvanized iron, which is comparatively inexpensive, not only reduces this factor, but makes the apparatus light and not easily broken.

To provide for the notorious lack of skill shown by native workmen, steps have been taken to make it absolutely necessary for the apparatus to be set up correctly. It is practically impossible to make it work in any other way than the correct one. Each and every part must occupy its correct relation to every other part, and of necessity this must be carried out in order to evolve fumes.

In order to prevent any possible accident due to the catching fire of the camphor, a special fumigating pan has been constructed—this pan is circular in shape, with the edges turned downward and outward, making a total diameter of seven inches. In section it is concave, so that in reality it is a shallow bowl having a diameter greater than that of the stand upon which it is supported, with the edges turned down at an angle of 45° with the perpendicular.

This shaped pan is especially adapted to the evapo-

256 The Control of Mosquitoes

ration of any liquid; the concavity causes the last remaining portions of liquid to remain in the center of the apparatus, where it is exposed to the hottest part of the flame, and the convexity presented to the flame permits the maximum effect of the latter for evaporation. Inasmuch as it is made of galvanized iron, hammered out of one piece, there are no joints to leak, or solder to melt, and the form is eminently suited for stacking a large number, one inside the other, for transportation.

The stand of galvanized iron, riveted into a cylindrical shape, 6 inches in diameter, and $5\frac{1}{2}$ inches high. Near the top is a row of holes through which the hot air from the lamp escapes, forming a natural draft. This hot air acts upon the campho-phenique that may be near the edge of the pan, away from the direct action of the flame, causing rapid evaporation at this point as well as in the center of the pan, which sets into the top of the stand. The stand is supported on three iron legs two inches long in the clear, which is turned outward at right angles at the bottom one-half inch. This is done so that they may fit into appropriate straps in the bottom of the safety pan, in which the stand sets, to assure the correct placing of the latter.

The safety pan is also made of galvanized iron eleven inches in diameter. In the bottom are three straps into which the "turned out" part of the legs of the stand fit. In the center of the safety pan there is a ring one-half inch high, three inches in diameter, into which the alcohol lamp fits. With the stand confined in its proper place by straps, the lamp likewise placed in its ring, it will be seen that there is no possibility of any portion of the apparatus occupy-

ing an incorrect position. The safety pan not only holds the stand in position, but when half-filled with water forms an effective protection in case the alcohol lamp should begin to leak. Any lateral spurt- ing of the alcohol is prevented by the sides of the stand, and the excess alcohol would immediately be extinguished by the water.

It should be mentioned in passing that the edge which is turned down on the fumigating pan is to prevent the flame of the alcohol lamp passing over the edge of the pan, and thus setting fire to the camphor and carbolic acid.

To summarize:

We have an apparatus consisting of four parts, a fumigating pan, designed to evaporate campho- phenique, formaldehyde, or other similar liquid, with an especially moulded edge designed to prevent con- tact of the liquid with the free flame, and to concen- trate the fluid as it is evaporated in such a manner that the last portion shall be distilled off.

The stand is designed for steadiness, protection of flame from drafts, and to give rigidity to the evapo- rating (fumigating) pan.

The safety pan is intended to support in their proper relations both the stand with its pan and the lamp which supplies the heat for evaporation, as well as a safeguard against leakage of the lamp.

The lamp found to give the best flame, everything considered, is No. 15 metal spirit lamp manufactured by Whitall, Tatum & Co.

The whole apparatus is made as cheaply, durably, and easy of transportation as possible. It is so con- structed as to permit its use by unskilled labor, with a minimum chance for damage both to itself and

258 The Control of Mosquitoes

to the house or other structure in which it may be used.

The fumigating pan will use 8 ounces of campho-phenique when made in the dimensions given, namely, $6\frac{1}{2}$ inches in diameter exclusive of the overhanging edge, and $1\frac{1}{2}$ inches in depth in the center. With the alcohol lamp one-third full, ample time is given for complete evaporation of the liquid, with about five minutes to spare to allow for conditions which slow down the rate of evaporation. In a fairly tight house, with corrugated metal roof, tightly papered, campho-phenique has given practically perfect results. Four ounces of the camphor-carbolic acid mixture and sulphur in amounts varying from one to three pounds per 1000 cubic feet have been used for comparative tests. In several instances considerable leakage, due to the wind passing over the metal roof carrying off fumes, has occurred, but even when small leaks of known size have been made purposely no change in the results have occurred. We feel justified in saying that campho-phenique in moderately well-built tight houses will give as good results as sulphur, and considering the extra time needed for sulphur fumigation, at an equal, or more probably, a lesser cost.

In order to test the action of pyrethrum, sulphur, and campho-phenique upon fruit, a series of two experiments have been made under the same conditions. Bananas, quite ripe, mangoes, and oranges have been used in these experiments. The mosquitoes were not only placed in the customary positions in houses, but were also carefully hidden as much as possible in bunches of bananas to simulate conditions which would occur on ship board. The results showed that campho-phenique is less harmful than sulphur or pyre-

thrum to the fruit. There was very little darkening of the skins of the bananas or other fruit when exposed to this substance, and the bananas did not taste bad. Several observers made these observations simultaneously, tasting fruit before and after fumigation, and also carefully preserved controls. The indications are that campho-phenique is less harmful than sulphur. With the campho-phenique these insects were killed in every case; in the first trial, where the time of exposure was only three-quarters of an hour, one mosquito which was situated near the roof, where the fumes were practically removed by the action of the wind, survived for nearly half an hour, although it could not walk or fly. It was the only survivor of about eighty *Aedes calopus* placed in the building at that time. The mosquitoes hidden in the fruit were all killed. It is interesting to note that the first experiment carried out in a strong breeze, also resulted in a large number of survivals of mosquitoes in the house fumigated by sulphur, and that they too, were near the roof, where there was loss of fumes due to wind action.

Sulphur is decidedly objectionable in many ways; it kills mosquitoes, however, and may be looked upon as a nearly perfect fumigant for these insects. Pyrethrum, if it were more efficient, would do very well, although it leaves a decided coloration on light colored paint and is objectionable from the point of view of time consumed in fumigation, three or four hours being necessary, as a rule, for its combustion. Campho-phenique in well-furnished houses (which in the vast majority of cases are also well-constructed) is very much less objectionable than either of the above, and it combines this factor with the comparatively

260 The Control of Mosquitoes

short time necessary for its evaporation, and the fact that it leaves a very slight residual odor, which quickly disappears, so that the houses are comfortably habitable as soon as the cleaning-up process is complete. In such cases it has given quite as good results as sulphur, and, considering everything, is much the cheapest fumigant of the three.

CHAPTER II

THE SITUATION ON THE ISTHMUS BEFORE SANITARY WORK WAS STARTED

IN his Report on the Isthmian Canal, 1904, Colonel Gorgas stated:

In my opinion the sanitary problems are grave. The question of eliminating yellow fever from an endemic focus has only been once before successfully managed, and that was at Havana. And from this successful work, to argue that it is easy and simple, I think is not warranted. The malarial work on the scale at Panama is entirely new. It has never been attempted elsewhere, and any health officer who has any experience in enforcing measures of individual prophylaxis such as will be required at Panama, can understand how great the difficulties of administration will be. Personally, I believe it can be done, and I approach the work with great hope of success, but I know that it will be neither easy nor simple, that we will meet with many disappointments, and have to modify our plans many times.

YELLOW FEVER

From the knowledge gained in the anti-yellow fever campaign in Havana, Colonel Gorgas rightly

262 The Control of Mosquitoes

concluded that, in so far as yellow fever was concerned, the cities of Panama and Colon were the danger points for the Panama Canal. Both of these cities; Panama, with a population in 1904 of about 25,000, and Colon, of about 4000, are seaports situated within a few days' travel from ports where yellow fever is endemic.

Panama and Colon were infested with *Aedes calopus*, the conditions for the propagation of this species of mosquito being exceedingly favorable, as the climatic conditions permit mosquito breeding throughout the year. The people of Panama and Colon depended principally on rain water for their water supply. This was peddled by watermen, and kept in numerous vessels by householders.

Wells, cisterns, barrels, and many other varieties of water containers, were not protected in any way from the female *Aedes calopus* seeking a favorable place for ovipositing. In addition to the various wells and water vessels, a large number of the houses had eave-troughs, to catch the rain water, and conduct it to various storage devices. These troughs, or gutters, many of them sagging, and holding water, were also favorite ovipositories of this mosquito.

There was no systematized garbage collection.

Back yards were littered with refuse of all sorts, as were vacant lots, alleys, and even the streets. This rubbish included many articles capable of holding water, and serving as breeding-places for mosquitoes.

The difficulty of obtaining an ample and cheap supply of water resulted in extreme economy of water consumption by the people of Panama, especially among the poor. This economy found expression in the widespread custom of leaving dregs in the water vessels, and refilling them when the water ran low. To appreciate the full significance of this custom, it must be recalled that larvæ of *Aedes calopus* remain for the greater portion of the time near the bottom of a vessel; they descend, also, with great rapidity, when in any way disturbed. A five-gallon bucket may be nearly emptied by tipping, and if the water is not poured out very rapidly, most of the *Aedes calopus* larvæ will remain in the few teaspoonfuls of water left in the bottom of the bucket.

Ten years ago decorative shrubs in the grounds of Ancon Hospital, and in private grounds in Panama were protected from the ravages of the leaf-cutting ants, by surrounding each shrub with shallow ring-shaped dishes filled with water.

264 The Control of Mosquitoes

Each of these dishes was a mosquito incubator of a most efficient type.

The result of all these factors favoring mosquito propagation was, that the two cities harbored vast numbers of these insects. The *Aedes calopus* was the commonest mosquito in Panama, and the mosquito bars used by some of the natives were intended particularly as a protection against their annoyance.

Turning to the records of the four years immediately preceding the inauguration of sanitary work on the Isthmus, the available records of deaths from yellow fever in the city of Panama show:

| | | | |
|-----|--------|----|------|
| 109 | deaths | in | 1900 |
| 5 | " | " | 1901 |
| 202 | " | " | 1902 |
| 51 | " | " | 1903 |

These figures, however, indicate the yellow fever mortality in a population including few non-immunes. The accuracy of these statistics may also be challenged, as there was practically no sanitary organization in this province of Colombia, nor was the reporting of yellow fever compulsory.

With myriads of *Aedes calopus* on the wing, with

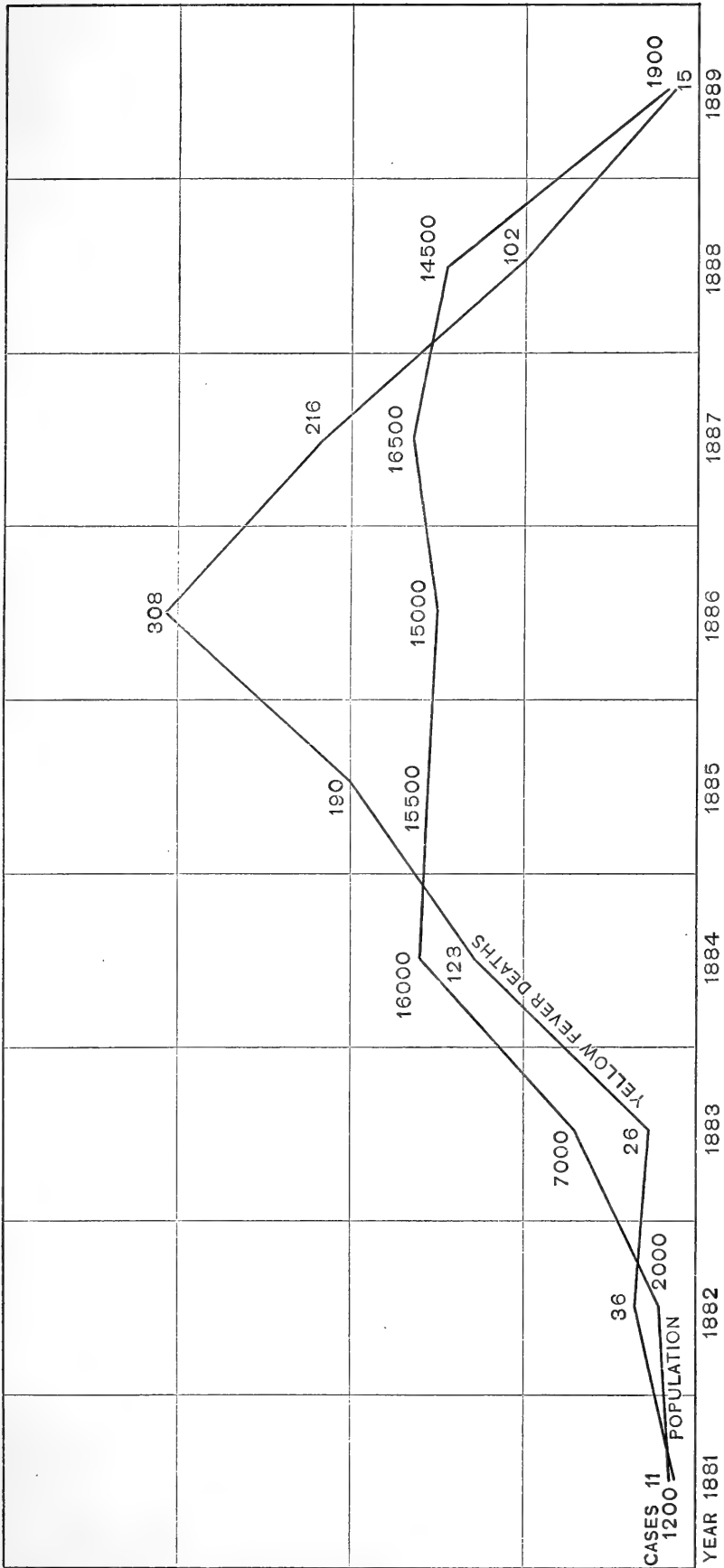

NON-IMMUNE POPULATION AND YELLOW FEVER
 FROM RECORDS OF FRENCH PANAMA CANAL CO.

AJO

3. CHART, SHOWING YELLOW FEVER CASES ON THE ISTHMUS FROM 1881 TO 1889

countless breeding places in and about the houses, with climatic conditions particularly favorable to rapid and continuous development of insect fauna, and yellow fever foci at the very threshold, what would be the expectation for rapid spread of yellow fever were a large non-immune population introduced into Panama, Colon, and their vicinities? A glance at the curves on the chart will furnish a basis for an estimate.

These curves were plotted from the figures published by Colonel Gorgas in a pamphlet issued in 1906, entitled: "Population and Deaths from Various Diseases in the City of Panama, by Months and Years, from November, 1883, to August, 1906. Number of Employees and Deaths from Various Diseases among Employees of the French Canal Companies, by Months and Years, from January, 1881, to April, 1904." The number of employees given is nearly correct, but the number of deaths from yellow fever is probably much below the correct number. The only mortality statistics available are those of Ancon Hospital, and many cases of yellow fever never found their way into the hospital, either dying before they could be sent there, or remaining outside because the contractors were more or less reluctant to pay for the treatment of their employees. After carefully investigating various

266 The Control of Mosquitoes

sources of information, the authors believe that the number of cases given in this table approaches the true mortality more nearly if multiplied by two. Basing the estimate on a case mortality rate of 33% with an average population of 15,000 in 1886, the number of deaths given in the statistics is corrected to the more probable number 616 (308×2); the cases developed during that year must have exceeded 1500 or ten per cent. of the entire working force.

The year 1886 was the fifth of the French occupancy, the year during which the work was at its height, and when the number of non-immunes was comparatively high. This year can be taken as a fair basis for an estimate of the mortality from yellow fever that would probably have had to be faced by the American forces on the Canal. The average force employed by the United States on the Canal was 35,000 to 40,000 mostly non-immune to yellow fever. With a mortality of four per cent. per annum, as was the case with the French force in 1886, we should have lost more than 1400 men each year from yellow fever alone!

The curves on the chart show a very interesting phenomenon, in the rapid rise of yellow fever with the influx of non-immunes; this rise taking place

Conditions before Sanitation 267

at a swiftly accelerating rate; then the decline as the non-immunes either die or recover from the disease; and the subsidence of the epidemic as the non-immune material is exhausted.

CHAPTER III

GEOGRAPHY, METEOROLOGY, ETC., AND THEIR BEARING ON THE PRESENCE OF AÆDES CALOPUS

THE Canal Zone is a narrow strip of land ten miles wide and approximately forty-eight miles long, situated entirely within the torrid zone. Its northern boundary is in latitude $9^{\circ} 24' 40''$ N. (vicinity of Punta Mala Remo). Its southernmost latitude is $8^{\circ} 54' 40''$ N. (Punta Bruja). The seasons are well marked: a rainy season of nearly eight months' duration and a dry season of about four months, January to April.

The mean annual temperature is approximately 80° F.

The extreme range of temperature is between 68° and 97° F.

The climate and temperature are favorable to mosquito propagation the year round.

In 1904 when the Canal Zone was ceded by the Republic of Panama to the United States, it contained a number of villages and small settlements;

two of these were at the ocean terminals of the Canal, Cristobal on the Atlantic, and La Boca, recently renamed Balboa, on the Pacific. In addition to these were the cities of Colon and Panama, which although not in the Canal Zone politically, are yet geographically so, and were placed within the sanitary jurisdiction of the United States by treaty.

Colon and Cristobal are situated on Manzanillo Island, a flat marshy piece of land the elevation of which is approximately four feet above mean tide. This island is largely a coral formation covered with a layer of soil. There are no rivers or springs on the island, and no wells. Formerly the only source of water supply for Colon was rain water and fortunately the precipitation in this locality is very great, averaging 120 inches annually. Some water was brought into Colon by rail and stored for use. The towns in the Canal Zone depended for their supply on adjacent rivers, streams, and springs, which are plentiful in the Zone. Panama, Ancon, and Balboa (La Boca) are situated at the southern extremity of the Canal. The rainfall there is far less than on the Atlantic slope, averaging about seventy inches per annum. The stored rain water was therefore supplemented by wells and aqueducts carrying surface and subsoil water, with tanks for storage.

The owners of the aqueducts and wells sold the water to carriers, who in turn sold it to the consumer. The price of water sold from the carts was usually five cents for a five-gallon can and sometimes doubled toward the end of the dry season.

It will be seen from the foregoing that climatic and topographical conditions are very favorable to *Aedes calopus* in the Canal Zone, and especially in the cities of Panama and Colon. In the adjacent settlements of Balboa, Ancon and Cristobal, where scarcity of water compelled each household to husband to the utmost any supply obtainable, the result was that these cities and their environs harbored thousands of ideal mosquito breeding places.

CHAPTER IV

THE FIRST SANITARY WORK DONE AT PANAMA—ITS PURPOSE

IN July of 1904, when Colonel Gorgas and his assistants undertook the sanitation of the Isthmus, it was not definitely known that yellow fever was present. The authorities were not aware of any cases. At least none had been reported in the months of February, March, or April, 1904, and there was reasonable doubt regarding the diagnosis of the two cases reported in May and June. The number of non-immunes was relatively small in proportion to the native population. It was understood, of course, that as soon as the percentage of non-immunes to total population increased, if yellow fever were present, a number of cases would develop, unless the chief sanitary officer had the necessary organization, police power, supplies, appropriations, and power to enforce the sanitary regulations; in brief, that unless the proper means were used to combat

the disease in its incipience, conditions would be favorable for an epidemic as soon as enough American non-immunes arrived.

Colonel Gorgas earnestly endeavored to have a properly qualified representative of the sanitary department on duty in the United States, so that all supplies necessary for the control of yellow fever and operation of the hospitals might be properly selected, expeditiously purchased, inspected, and rushed to the Isthmus without delay. Delay, he foresaw, might result in many deaths among Americans, and cause a longer and more expensive yellow fever campaign. His recommendations regarding this matter were, unfortunately, not approved.

The treaty between the United States and the Republic of Panama contained the following clauses:

The Republic of Panama agrees that the cities of Panama and Colon shall comply in perpetuity with the sanitary ordinances, whether of a preventive or curative character, prescribed by the United States; and in case the government of Panama is unable or fails in its duty to enforce this compliance by the cities of Panama and Colon with the sanitary ordinances of the United States, the Republic of Panama grants to the United States the right and authority to enforce the same.

In accordance with the terms of the treaty, the Republic of Panama agreed that the sanitation of the cities of Panama and Colon should be directed by the chief sanitary officer of the Isthmian Canal Commission. At the request of the latter, the Mayors (Alcaldes) of the cities of Panama and Colon issued the following ordinance:

Ordinance Number 6. Under the authority granted by decree No. 25, of July 8, 1904, issued by the President of the Republic of Panama, the following sanitary regulation is issued:

Breeding of mosquito larvæ (wigglers) is prohibited within the limits of the city of Panama and the occupants of premises will be held accountable for violation of this regulation.

All cisterns, water barrels, and deposits of fresh water must be made mosquito-proof, and all occupants of premises must see that other deposits of water are so arranged that mosquitoes cannot breed in them.

Violation of this ordinance will make the offenders liable to a fine of five dollars gold.

(Signed) W. C. GORGAS,
Chief Sanitary Officer.

Previous to sailing for the Isthmus, the chief sanitary officer called the attention of the Isthmian Canal Commission to the advisability of immediately obtaining experienced assistants and sanitary supplies. He submitted an itemized list showing what was required. Although the

274 The Control of Mosquitoes

estimated cost was not large, the amount allowed him was below the sum asked for.

The first house to house inspection of the city of Panama showed that *Aedes calopus* larvæ existed at practically every house in town. Adults of the species were plentiful everywhere, and everyone who could afford it used mosquito bars. Foreigners found it impossible to sleep comfortably without a mosquito bar, and one could not sit down even in the daytime without being annoyed.

The ice supply was limited and ice was expensive, five dollars per hundred pounds, when obtainable. The natives cooled water by keeping a supply indoors in semi-porous earthenware vessels, called *tinajas*. In these larvæ thrived in great numbers inside the houses, as well as in the barrels, etc., in the patios.

After the first inspection of the town was completed, and proper notices published in the press concerning the proposed campaign against mosquitoes, a second inspection was made, and at all places where mosquito larvæ were found, the owners of the water containers were requested to assist the sanitary officers by complying with Ordinance Number 6. The number of containers with mosquito larvæ was reduced. A written notice was next sent out, inviting the attention of those

who were violating the ordinance to the fact that they would be liable to prosecution, in accordance with the ordinance; and in every way possible, a strong effort was made to obtain the people's support.

Subsequent inspection showing many delinquents, their names and addresses were forwarded to the mayor of the city, who had authority to impose fines. Practically no fines were imposed, and the people of the lower class, finding the ordinance not insisted on by the mayor, gave it little attention. Each week a list of citizens violating the ordinance during that week was duly forwarded to the mayor. It is not known if any natives were fined although rumor had it that some foreigners were.

The number of American employees and foreign population increased as time passed. Every means was used to induce the Mayor to enforce the law, and render the work effective, but without result.

The first case of yellow fever occurred at the San Tomas Hospital on November 21, 1904. The patient was an Italian, and came from a restaurant at Santa Ana Plaza, near the center of the town. The case was at once isolated in the mosquito-proof ward of the hospital. During De-

276 The Control of Mosquitoes

ember six cases developed. There were no deaths. No cases appeared among Canal employees in 1904. In January, 1905, eight more cases were reported, two resulting fatally. Three cases of yellow fever developed on board the steamship *Dora*, en route to Havana from Colon. They were Italians, members of an opera troupe, and contracted yellow fever while sojourning in Colon. Two of these cases terminated fatally.

An outbreak of yellow fever occurred on the U. S. Cruiser *Boston*, while she was at target practice at Chame Point, in Panama Bay. The *Boston* was in Panama harbor during November, 1904. Six cases developed on board the ship. The vessel was thoroughly fumigated, and no further cases followed.

It was evident that strenuous measures were needed to control the situation; but little help could be counted on from the local native authorities, and with the constantly increasing number of non-immune arrivals, yellow fever cases would increase in number, and assume the form of a serious epidemic. The inspection force was therefore increased to enable the inspection of all houses once a week. All containers found with mosquito larvæ were washed out. Tanks and larger vessels that could not be freed from larvæ

in this manner were treated with oil. Sufficient oil was used to cover the water surface completely. As the force became more experienced, better control was established.

In the early part of 1905 there was a large number of non-immunes in the city of Panama, and it became necessary to work with increased vigor, because, even with a greatly reduced number of *Aedes calopus*, the chances for the spread of yellow fever increased.

The fumigation work proved the marked effects that elimination of the containers had made on the eradication of *Aedes calopus* by the decreased number of dead insects found after fumigation. Ultimately we controlled the situation to the extent that but one per cent. of the houses were producing larvæ, and inspection work caused a large percentage of larvæ to be destroyed. One of the difficulties was in locating hidden containers. A few of these in a single block of houses were sufficient to enable *Aedes calopus* to reach other houses and decrease the efficiency of the work. As the ordinance was not properly supported, it became evident that the sanitary department would be obliged to undertake the task of screening, and making inaccessible to mosquitoes, all water barrels, tanks, cisterns, wells, etc. This

278 The Control of Mosquitoes

work had to be done thoroughly, or was of practically no value.

The city was divided into eleven districts for purposes of house to house inspection for locating and eradicating breeding places. An inspector was assigned to each district. He rendered daily reports of the status of each house visited, with regard to water containers. The force employed was composed largely of natives, who did not at first realize the importance of their work. They were fully instructed as to their duties, and their work was checked. When doubt arose as to the quality of the inspector's work, half a dozen of the houses in his district were inspected the day before he visited them, and his reports were checked against the special inspection reports.

Then, again, the districts were changed at frequent intervals, which served as a check on each man's work, so that before long each inspector either became efficient, or was replaced by a better man. The reason for reinspection and changing of inspectors was to determine the amount of time required for inspecting the districts, and to teach the men not to miss a single container. Every man was checked, and had to work with about the same rapidity, cover as much ground, and show as thorough results as the most efficient

man on the force. The scheme worked out well, although at first, in the weeding-out process, many changes occurred in the force.

Reinspection was continued throughout the entire campaign, to prevent unsatisfactory conditions in any district. A record of every house was kept, and those in which mosquito larvæ were apt to be found most frequently became known to the department, and were watched more closely. These house records showed the number of wells, tanks, cisterns, barrels, etc., within each. In order to eradicate these sources of mosquito production, a force of carpenters was employed to make mosquito-proof covers for them, and another gang to attach the covers to the containers. After they were placed, it became the duty of the inspectors to report any that had been detached or tampered with. When a cover was taken off a barrel or well, the water container was considered a menace to health, and was removed or destroyed. All containers not absolutely necessary were removed, and properly disposed of. The examination of the larger water containers, *tinajas*, open-top stone filters, etc., in dark corners of the houses, consumed much time. These vessels were listed, that none might be missed, and inspectors had to report the condition of each

one at every inspection. House tenants hid containers, and could never understand why an inspector who had missed a container one day always came in search of it the following day. A small acetylene lamp or an electric flash lamp was used to determine the presence of mosquito larvæ in large containers in dark places.

The non-immune residence sections were located in three limited areas, and especial care was taken in these localities. Most of the Americans in Panama in 1905 were employed by the Isthmian Canal Commission, and the greater part of them worked in what was then known as the "Canal Building," which occupies an entire block and is three stories high. Naturally, this building, if it contained infected mosquitoes, would become an important focus for the spread of yellow fever. To prevent such an occurrence, two inspections for water containers were made weekly, and the entire building was fumigated once every fortnight. It was found that the screened doors leading onto the verandas were propped open or held open by the janitors, and that mosquitoes actually gained access to the building through these doors. In order to prevent this, the department of sanitation placed a lock on each veranda door, and kept them locked, with the keys in charge of one re-

sponsible man. Only one entrance door to the building was allowed, and a watchman was stationed continuously at that door to see that it was not left open a moment longer than necessary.

It was unfortunate that greater power was not given to the chief sanitary officer, to enable him to prosecute the yellow fever campaign more rapidly. Under the organization then in power, he was often limited to making recommendations, which were not always carried into effect. Those inexperienced in matters pertaining to yellow fever control cannot and should not be expected to take part in the work of its suppression, unless they are subject to the orders and under the direct control of the officer charged with the eradication of yellow fever.

A case in point was that of the so-called Canal Building in Panama, the original headquarters of the Canal force. There was much delay in having the building properly screened. The architect who had charge of this matter was overworked, and busy with plans and estimates for the repair and construction of buildings all along the line of the Canal. Work was waiting for all the men available, and there was not enough room to accommodate the needed force. Of course, the architect's first consideration was to provide housing facil-

282 The Control of Mosquitoes

ities. The sanitary department thought it of prime importance to have the building, which was located in an infected area, properly screened, as it was used almost exclusively by non-immunes. The importance of neglecting some other work, if need be, and attending immediately to the screening of the Canal Building was brought to the attention of the architect time and again, but he thought the matter of secondary importance compared with the work he was doing elsewhere, and the screening was delayed. The architect even joked about the fuss made over the screening. He had not lived in tropical America before, and had but little faith in modern ideas pertaining to yellow fever transmission and control. This able and efficient young man was among the first Americans who died of yellow fever, contracted in the building he had not screened, and other employees in the offices in the same building also contracted the disease. It cannot be said that the architect was responsible for his own death and the death of the others: the source of the trouble was higher. When the power of the sanitary officer is limited, the efficiency and speed in obtaining results will always be limited proportionally, and often with very serious results.

The non-immune population lived in Panama

in three well-defined areas: the Italian colony on Malambo Street, the Americans near Central Park, and a considerable number near Plaza Santa Ana. Many Americans lived in the Ancon Hospital Reservation. The buildings in these areas most likely to harbor yellow fever cases were fumigated every two weeks, to eradicate any infected mosquitoes that might be present. It is remarkable that in Ancon Hospital, where most of the yellow fever cases were cared for, no cases of yellow fever were contracted. The reason for this was, that the hospital grounds were under the direct control of the chief sanitary officer, and the few adult *Aedes calopus* remaining there were not allowed to enter the buildings after they were once screened. Everybody in the hospital coöperated to prevent them from getting a foothold, and all were interested in the results of the anti-mosquito campaign.

It was often difficult to locate the house where a yellow fever suspect had been bitten by an infected mosquito. In instances of yellow fever "walking cases," not infrequent in the early stages of the disease, the source of the infection may never be located.

When a case or a suspected case of yellow fever was reported we obtained from him as promptly

as possible a list of the places he had frequented (so far as he could remember), and a list of his friends or relatives. We questioned them in turn to make the history of the patient's previous movements as exact as possible. We often received conflicting testimony, and the patient in many cases was not in a condition to remember where he had been at the time of infection, or since. It was very important to obtain this information, so that effective measures might be taken to destroy by fumigation the infected mosquitoes that had inoculated the patient, and that the *Aedes calopus* which had bitten him during the first three days of the disease be destroyed, before they in turn should become infectious and bite non-immunes.

In some cases the patients were delirious, and gave no clue to their history. In a few cases false information was given and the much-needed facts withheld. The missing of one link in the chain of evidence meant leaving some infected mosquitoes alive, with the possibility of secondary cases. As some cases occurred which could not be traced to previous known sources of infection, it was decided to fumigate all houses in the city of Panama in succession as rapidly as possible. The fumigation brigade was increased, and the work pushed as rapidly as conditions would per-



Part of the Panama fumigation brigade

mit. All the houses in one or more blocks were fumigated in a single day. Block after block was fumigated from one end of the town to the other. At this time we had a number of cases of yellow fever, and though the myriads of mosquitoes were greatly reduced, the comparatively few remaining, together with enough cases of yellow fever and a large non-immune population, made transmission easy.

The following measures were adopted to insure knowledge of every case as rapidly as possible.

Reporting of suspected cases of yellow fever, and of all fevers among non-immunes, was made compulsory by the following section of the sanitary rules and regulations for the cities of Panama and Colon:

Contagious Diseases.

Section 10. Every physician, druggist, school teacher, clergyman, midwife, nurse, and every head of a family, having knowledge of any case of the following named diseases, shall immediately report the same to the Health Officer: Asiatic cholera, yellow fever, typhus fever, smallpox, plague, dysentery, diphtheria, and membranous croup.

All hotels, etc., were required to keep a register, and a physician visited every hotel and boarding house daily to ascertain whether any non-immune

286 The Control of Mosquitoes

residents were sick. In order to prevent the concealing of cases, patients were not compelled to go to hospital, but could remain at their residences and be treated by their family physicians under conditions specified by the chief sanitary officer. In addition, a reward of \$50.00 was paid to the first person reporting a case of illness which was subsequently diagnosed by the Yellow Fever Board as yellow fever.

When a suspected case of yellow fever was reported, the patient and his relatives or friends were interviewed, and an effort made to transfer him to Ancon Hospital. Almost all Americans acceded. Where the patient preferred to remain at his home, his room was at once made mosquito-proof. The windows and all doorways except one were screened with immovable screens. The single entrance door was fitted with a vestibule provided with two screened doors. Both these doors were fitted with strong springs to make them self-closing. The outer door was kept locked, and the key was in charge of a guard employed by the sanitary department. These guards were on duty in eight-hour shifts, that the door might not be left unguarded until the patient was removed from the room. At the termination of the case his room was fumigated,



Screened vestibule door



the adjacent rooms and houses having already been so treated.

No non-immunes were allowed in the patient's room. His physician, nurse, and possibly one or more immune friends, with the approval of the chief sanitary officer, were allowed to enter the screened room. No one could pass the guard without written authority.

In Ancon Hospital two wards and several private rooms were used solely for yellow fever suspects. To enter the wards it was necessary to pass through a vestibule provided with three screened doors. A pan of pyrethrum powder was kept burning constantly between the last two doors, and a guard was always present to see that the doors were opened and closed rapidly. The nurses and physicians learned to pass through the doors quickly and inspected the wards daily for *Aedes calopus*. The windows were screened on both the inside and outside and examined twice daily for defects. The buildings and the grounds in the vicinity of the hospital were frequently inspected for possible water containers.

All of the nurses and many of the physicians were non-immunes, but no case of yellow fever developed among those caring for the patients and living in the hospital grounds, although at times

288 The Control of Mosquitoes

there were as many as 200 Americans living there. All suspects arriving at the hospital were placed in beds under large screened cages located within the screened wards, and the yellow fever cases were kept in these cages during the first five days of their illness. These precautions made it necessary for a mosquito to pass through a cloud of smoke and four screened doors before it could reach a patient, and then escape through a door into the ward, where it must survive a twelve days' search for mosquitoes before attacking a non-immune. It was almost impossible for such a combination to happen, and it never happened.

When the yellow fever wards were first fitted up, no metal screening was available. Cotton mosquito bar had to be used for screening the buildings, and with care and the precautions taken, it gave satisfactory results. Its fragile nature renders it unserviceable for extensive use, but in an emergency it can serve, as at Ancon.

With the installation of water and sewerage systems in Panama, it became unnecessary to use water containers for storage purposes, and as fast as water was installed in each house, the tanks, barrels, cisterns, etc., were removed or destroyed. This assisted to a very large extent in eliminating mosquitoes. But public water and sewer systems

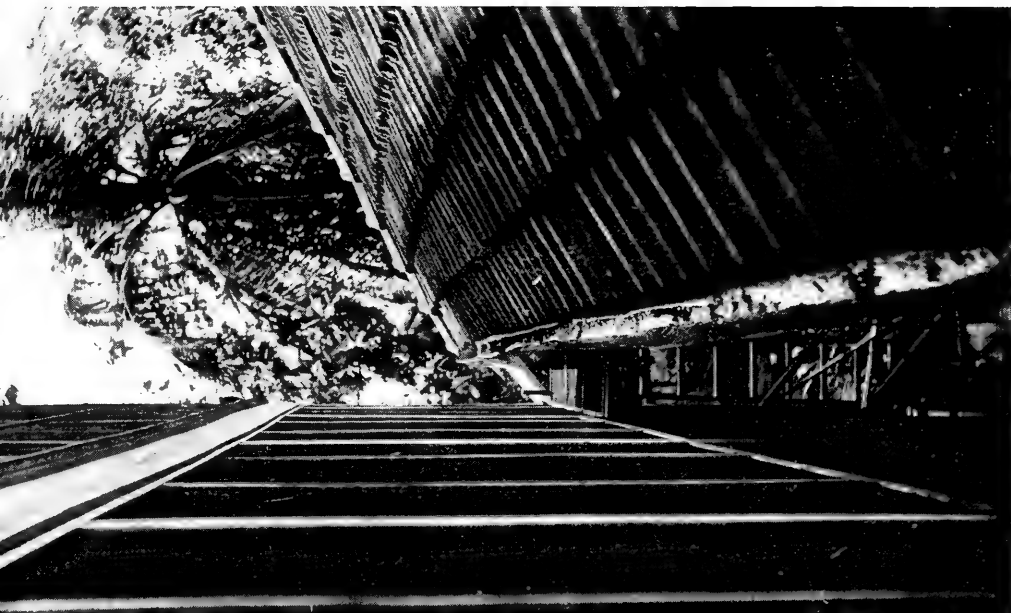

A poorly constructed eave trough

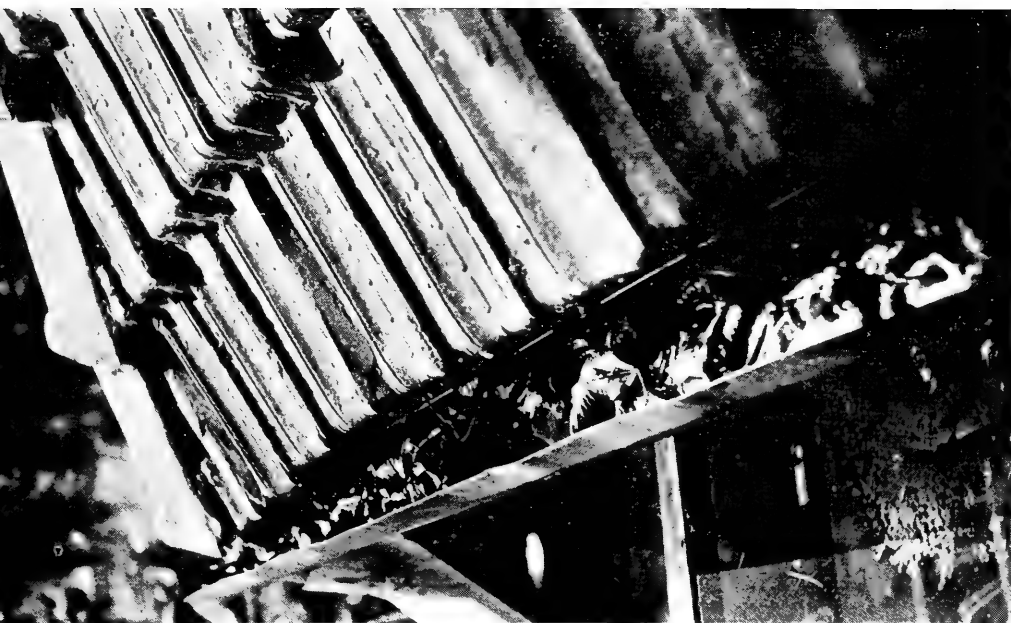

A clogged eave trough

alone do not rid a Central American community of them. Rain water is soft, and people were accustomed to use it. The widespread custom

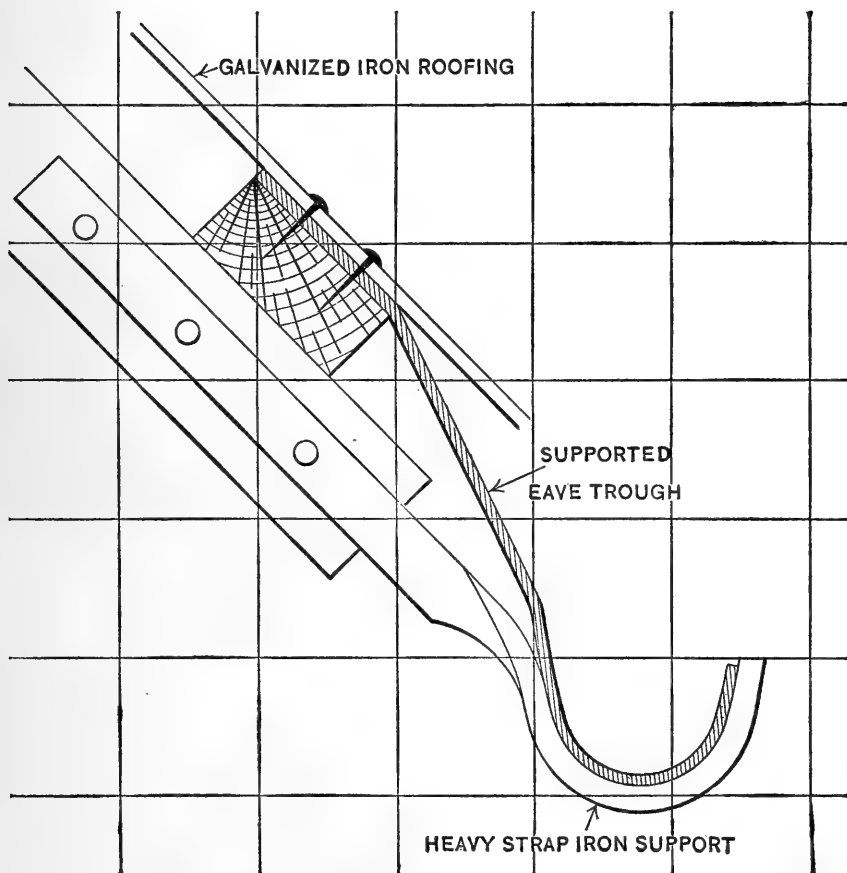

A firmly supported eave-trough.

of collecting and keeping it was difficult to eradicate.

Aedes calopus breeding also occurred in the eave-troughs, which sagged, and were difficult to

290 The Control of Mosquitoes

inspect. Eventually they were all removed. The *tinajas* are still used, but as water costs much less than formerly, they are emptied more frequently, and are less dangerous.

In localities where there is no available water supply other than rain water collected by roofs of buildings, it may be absolutely essential to use eave-troughs to obtain all the water possible for storage and future use.

If eave-troughs are used for that purpose they should be made of galvanized iron of sufficient thickness to prevent sagging, have a good slope, and be securely attached to the roof. It is necessary to have the points of support as close together as possible. They should be arranged to permit inspection without leaning heavy ladders against them. Eave-troughs are convenient but nearly all towns where the yellow fever mosquito is found could do without them.

In an anti-yellow fever campaign, it is not safe to rely on fumigation only, for we cannot be sure that all the places in which infected mosquitoes exist have been fumigated. It is only possible to accomplish a certain amount of fumigation in one day, and meanwhile mosquitoes in the adjacent unfumigated buildings may return. It is evident that fumigating on a wholesale scale, *i.e.*,



Mosquito-proof water-barrel

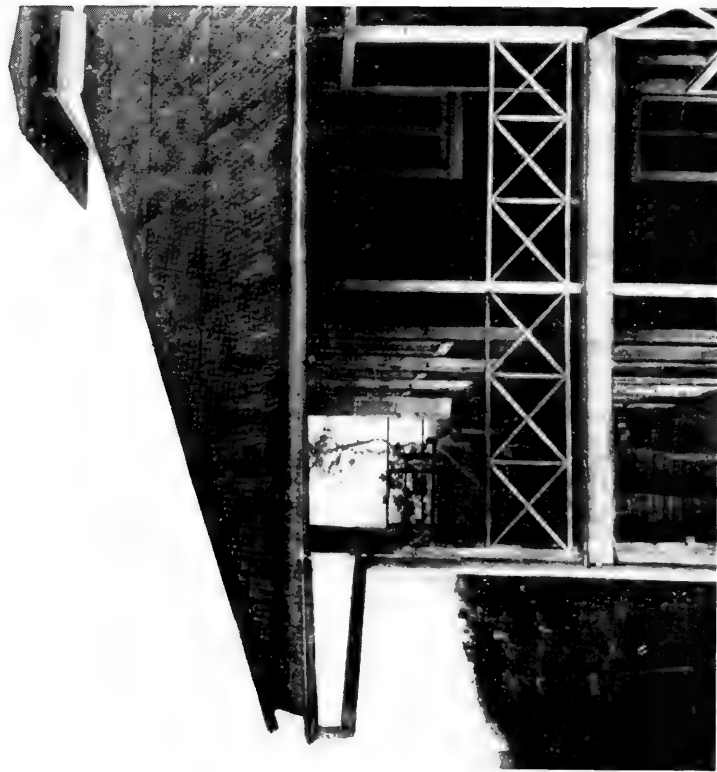

A firmly supported cave trough with good slope



fumigating all houses in a town or village, will not necessarily kill all the mosquitoes present in and about the houses, though probably the greater part may be destroyed. It is surprising how soon they will disappear, if all the water containers and places in which they oviposit are removed. We believe that the thorough and rapid destruction or protection of all possible containers and breeding places is the most effective method of yellow fever control, and that where the health officer is supported by the residents, *Aedes calopus* eradication is quite possible. The campaign at Santiago de las Vegas, Cuba, proved this beyond doubt.

It is not absolutely necessary to eradicate all *Aedes calopus* in order to eradicate yellow fever. It is only necessary to reduce the number of adults sufficiently to prevent their presence in the vicinity of the places visited by non-immunes.

The matter can be stated thus: In order to eradicate yellow fever from a given community it is necessary to reduce the number of *Aedes calopus* to such a minority that there is no opportunity for their biting an infected case during the first three days of the disease, and surviving twelve days after. Of course, the nearer the reduction reaches complete eradication the better, especially in re-

gard to the reintroduction of the disease at some future time.

When the reduction of *Aedes calopus* has reached a certain stage, the chance of a person being bitten becomes so small that transmission of fever stops. Yellow fever was eradicated in the epidemic at Havana, Santiago, and other towns and villages in Cuba, as well as in the Canal Zone and the cities of Panama and Colon, when the number of *Aedes calopus* present was much higher than now. Since the last case of local origin in 1906, on several occasions imported cases have gained access to, and actually been at large in Panama and Colon, without producing secondary cases; because the number of adult *Aedes calopus* is so small that there are almost no chances of completing the chain necessary for the transmission: a patient being bitten, this particular insect surviving twelve days, and then biting a non-immune. In some settlements in the Canal Zone *Aedes calopus* are now seldom seen.

It must be remembered, however, that but a short time is needed to reintroduce this species of mosquito, and that if conditions are allowed to become favorable, it will both multiply and spread over a populated area with great rapidity.

CHAPTER V

THE ANTI-YELLOW FEVER CAMPAIGN AND ITS RESULTS

AFTER the arrival of Colonel Gorgas and his assistants on the Isthmus, preparations for the campaign were begun before the first case of yellow fever was reported. As rapidly as possible all barrels used for storing water were made mosquito-proof. Wooden barrel covers with wire-gauze protected openings were made and shipped to the different villages. These were nailed to the barrel tops by the sanitary department, to leave no doubt of their remaining mosquito-proof. An inch or so below the top of the barrel an augur hole was made, and mosquito wire nailed over it. This hole was intended for an overflow, to prevent the water from coming in contact with the wire-gauze covered opening in the top, and thus inviting ovipositing.

The covers were made by fastening together two boards about twelve by twenty-four inches, leaving

294 The Control of Mosquitoes

an opening four inches square when the boards were fastened together. This opening was covered with a square of eighteen mesh copper wire gauze, protected by placing above it a square of half-inch mesh galvanized iron wire, and the whole fastened in place with wooden strips. A wooden spigot was inserted near the bottom of the barrel.

It was necessary to see that the edge of the barrel was "true," and when not, to correct it; otherwise the cover would not fit snugly and the entire work would be useless.

Prompt results in mosquito control may be obtained by making water barrels non-accessible to mosquitoes in the following manner. Muslin or sacking is fastened securely over the top of the barrel, and also over a one-inch overflow hole six inches below the top. The water is obtained from a wood or metal faucet.

The use of this scheme on a large scale necessitates much careful inspection and also coöperation on the part of the house tenant. When careless people remove and replace this barrel covering, the barrel may be left temporarily uncovered and mosquitoes propagated and liberated unknown to those conducting the anti-mosquito campaign. The cloth should be kept

free from holes and be fastened to the top of the barrel with strong wire. The twisted portion of the wire must be so sealed that it cannot be unfastened or replaced without the fact being easily detected. Although this method of control is often not satisfactory, it may sometimes be helpful. It is rapidly installed, inexpensive, and may serve temporary purposes.

At first the natives took off the covers, and did not replace them properly. When taken to task about this, they professed a desire to clean the barrels. Observation proved that before the barrels had been covered they had seldom been washed out; then it appeared that the people were so accustomed to dipping out the water, they did not want to use the spigots. This practice was soon stopped.

When the sanitary work was started, the houses in the villages were mostly surrounded by jungles or high grass. All bottles, cans, and other potential water containers and rubbish were thrown out of doors, and hidden by the vegetation. It was therefore necessary to do much clearing of vegetation and collecting of water containers. Within a week or two after this work was completed the grass was high again. Much effort was required to make tenants place useless water

296 The Control of Mosquitoes

containers within the garbage cans. Where the houses were close together it was difficult for the inspectors to find the guilty individual. Apparently it was not easy for the people to change their habits. It was found necessary to keep the grass short near houses, so that water containers could be easily found.

The interiors of all houses were inspected for water containers, which disappeared as the inspector approached. Usually the tenants emptied water vessels at the back door, while the inspector was entering at the front.

In 1904 houses in the Canal Zone were not screened. Each American employee was furnished with a mosquito bar, but they were not used in a way to make biting impossible. Even bars that were intact, when improperly tucked in around the mattresses, proved ineffective. Many people roll in bed, and thus come in contact with the mosquito bar while asleep; and mosquitoes bite through the bar and the sleeper may be unaware of it. It was also found that bars were easily torn, and seldom promptly repaired. In order to make the bars effective, the sanitary department undertook to keep those of canal employees in repair, free of charge.

After the houses were screened, and the number

of adult *Aedes calopus* became very small, no more bars were used. At the present time they are unnecessary and are not used by people in the Canal Zone.

We learned by experience that when mosquito bars must be used, the following precautions should be carefully observed.

1. The bar should be ample in size, and made of durable material of considerable tensile strength.

2. It should be carefully tucked under the mattress, or if no mattress is used, under three sides of a piece of matting laid on the bed or cot. Just before entering the bed, the interior of the bar should be carefully searched for mosquitoes, and those within destroyed. When a mosquito is hidden within a net, a small electric flash lamp helps to discover it.

3. Enter the bed quickly, disturbing the bar as little as possible.

4. Tuck in the bar carefully on the side through which you enter.

5. Sleep in a wide bed, and cultivate the habit of sleeping quietly in the middle of it.

We knew that yellow fever would occur at Panama and Colon as soon as the percentage of non-immune population was sufficiently high to favor its propagation. As it was proposed to

concentrate the newly arriving Americans at La Boca, Ancon, Culebra, and Gorgona, a strong effort was made to control the *Aedes calopus* production at these villages as rapidly as possible. It was expected that the employees quartered in these settlements would visit the terminal cities, and that some of them would contract the fever. Every effort was made to prevent transmission of yellow fever from any of those who might have become infected in Panama or Colon, to others living at the villages mentioned. The first cases of yellow fever in the Canal Zone developed at Culebra, Balboa, and Corozal. All Americans living at Corozal worked in the city of Panama and none of the residences of the employees were screened when yellow fever first appeared. When the first cases occurred, the history of every patient was rapidly obtained. All places visited by them since their infection, and where they might have become infected, were fumigated with sulphur, as were also all adjacent houses. The patients whenever possible were removed to the yellow fever wards at Ancon Hospital.

The fumigation was at first a difficult task to accomplish. The sanitary department was allowed to pay only the lowest rate of wages current, and

consequently only poor and unintelligent labor could be obtained. Any intelligent laborer could find employment elsewhere at a higher rate of pay. Even the men employed for scavenging and ditching were used as a fumigation squad. Some of them had not enough sense to hurry while working in sulphur fumes. It was not unusual for them to leave us while fumigations were in progress, for working in sulphur fumes day after day at the lowest rate of wages was not attractive. At that time in the Canal Zone a laborer could find work anywhere else for the asking and often at higher wages. The sanitary inspectors deserve great credit for the manner in which they won success in spite of the numerous difficulties they faced. Apparently many of the laborers had never moved with celerity before in their lives, and some of them could not even climb a ladder. Others who went into the rooms to open windows after fumigation did not understand enough to return quickly, and were dragged out in a state of collapse. This was the *only* class of labor allowed the sanitary department. We had to use it, and succeed or fail.

Many of the native houses were so loosely built, and so full of cracks, that it was necessary to paste paper over the outside of the greater part of them,

and contend with leaks in the roofs also. At times ten pounds of sulphur per thousand cubic feet of air space was used, to obtain a maximum of fumes in a minimum of time, and allow for leakage.

Non-immunes stationed in the Canal Zone were advised not to visit the terminal cities except when absolutely necessary, because yellow fever was more prevalent there than in the Zone. Even the train schedule was changed on Sundays, to make it inconvenient for American employees from the Zone to remain long in the city of Panama. The object was to keep non-immunes away from the infected mosquitoes as much as possible.

Two cases occurred in the Zone that were of special interest. The first was at Paraiso; the patient was a locomotive engineer, and he had not left his home district except for about an hour and a half during the period in which he could have contracted yellow fever. On that occasion he had traveled three miles from Paraiso to Culebra in his engine cab, and arriving at Culebra, stepped out of his machine and into the pay car, where he remained only long enough to collect his pay. He at once returned to Paraiso with his engine. There was such a crowd moving about the pay car and its vicinity, it was not probable that any

Aedes calopus hovered in the vicinity, and there was no house near.

No case of yellow fever had occurred at Paraiso. What was the source of infection? The histories of all cases that might be the source of the infection of the last case were reconsidered, and in point of time occurrence only one case seemed important. It was that of a peddler in the city of Panama, ill with yellow fever in the hospital. His history showed that he had not been to Paraiso, and on being questioned, he confirmed the statement. His friends corroborated it. The Paraiso case was still a puzzle. The patient's quarters at Paraiso, and adjacent houses, were fumigated to prevent secondary cases, and then the following action was taken. It was assumed that the possibility of infection at the pay car was too remote for serious consideration, and that some unknown infected person must have been to Paraiso before the engineer became sick. We visited every house, seeking for information, and received much confusing testimony. A second trip was made to determine if any stranger had been there to sell anything. We found that a man had been there selling trinkets similar to those in the above-mentioned peddler's box. It was finally proven that the Panama peddler had not only

302 The Control of Mosquitoes

been in Paraiso, but had rested in the shade on the porch of the house in which the American engineer slept. The peddler acknowledged this fact later, but refused to give any reason for his previous story.

Another case of interesting history occurred in the city of Panama. A man was arrested for intoxication. While arguing with a policeman, he was seen by a sanitary officer, and sent to the hospital. Soon after arrival he became delirious; he proved to be a yellow fever case, and died that night, leaving only a fragment of his history. His statement, as far as it could be understood, was that he was a native of Greece, had no friends in Panama, and lived at a certain hotel. The hotel proprietor said he had never seen or heard of the man. For a day and a half the city was ransacked for additional information, without result. It became known that the hotel proprietor was not sure if the man had stayed at his establishment.

Several men were employed to look up all the Greeks living in Panama. One of these learned that the case had been seen in an Italian café. The proprietor denied all knowledge of the fact. He was told that it would be necessary to close the café for a day for fumigation purposes, and he then volunteered the information that he knew the

deceased and knew that a fellow-countryman of his was a bartender at the old theater. A day's search located this person. He was in bed, sick with a pronounced case of yellow fever. He stated that he and his fellow-countryman had slept in the barroom of the theater. It was then too late an hour to fumigate the theater. It was closed and no performance permitted. The same night the daughter of the prima donna came down with yellow fever. She died a few days later. The data obtained showed a strong focus of infection at the theater, and this information prevented further spread of the disease. The theater was particularly dangerous, because non-immunes gathered there in numbers, and had infected *Aedes calopus* remained in the building they would have continued the infection.

The last case of yellow fever in the Canal Zone occurred at Matachin on September 28, 1905. The patient was the station agent. The case had a number of interesting features. For two months previous to the attack he had never left the village. No other case of yellow fever had occurred recently in the Canal Zone, although a few had been found in Colon. This was the first and only case that occurred at Matachin. The only case that it corresponded with in point of infection was that

304 The Control of Mosquitoes

of a man at Colon who had never been to Matachin. However, the agent remembered distinctly having been bitten about the ankles and wrists while checking freight in cars that arrived from Colon. This is a characteristic biting habit of *Aedes calopus*. Subsequent investigation showed that these cars had been located on a siding at Colon near the house in which the case of yellow fever had occurred, corresponding exactly as to time of infection with the case at Matachin.

At the time the yellow fever epidemic was coming to an end, the sewer system, water supply, and paving of the city of Panama were well under way. The old theory of the upturning of the soil being responsible for yellow fever was still believed by many. There was not a single case of yellow fever in the houses on or adjacent to the streets being torn up, nor in streets where trenches were being dug. Although the main water supply distribution system was installed before yellow fever was eradicated, it had but little effect upon the suppression of this disease. Few houses were at that time supplied with plumbing fixtures, and the native population preferred rain water, to which they were more accustomed. In subsequent years, as the houses became supplied with plumbing, less rain water

was collected, and rain water barrels were not allowed to exist. Of course this prevented the continuance of breeding places favorable to mosquito development, and has been an important factor in keeping yellow fever out of Panama. Attention is invited to the fact that the city of Havana had an excellent source of water supply, and nearly all the houses in its yellow fever district had water taps in houses and yards long before the first American occupation. But a water supply alone, or even one supplemented by a proper sewer system, is not sufficient to control yellow fever or *Aedes calopus* propagation. In Havana, there was as much mosquito propagation in houses occupied by Americans as in those occupied by natives. Systematic inspection by capable and energetic inspectors, working under a health officer especially trained for this work, is essential for yellow fever control.

CHAPTER VI

MEASURES TAKEN TO KEEP THE ISTHMUS FREE FROM YELLOW FEVER

ALL houses in the Canal Zone occupied by American and foreign employees are not only screened, but the screening is kept in effective condition, inspected at frequent intervals, and repaired whenever defects occur. The lower parts of doors and all other screens subject to abuse are properly protected. All houses near settlements and adjacent territory are inspected each week for possible mosquito-producing containers. Anything that can hold rain water is removed, or so placed that water cannot remain in it. Foremen of gangs are ordered not to leave any material exposed that may collect rain water. Water in or on objects that cannot be moved, is treated with oil or larvacide. Tin cans and other waste material are buried. Where water is collected in barrels or tanks at isolated houses, these containers are made non-accessible to the mosquitoes. Tall

grass is not allowed near settlements, as water containers may become hidden under it. Interiors of houses are inspected to detect mosquito-producing containers, and tenants are invited to complain to the district sanitary inspector when mosquitoes are noted indoors. All houses are inspected for *Anopheles* at frequent intervals, at which times a keen search is also made for *Aedes calopus*. When adults of this species are noticed, very thorough inspection is made of all houses and yards in the vicinity. Each week the district inspector reports the number of *Aedes calopus* breeding places found during the regular weekly inspection, and notes their location in the station diary. As his district is inspected by the division inspector, the assistant chief sanitary inspector, and the chief sanitary inspector, any neglect of duty is soon detected. As a matter of fact, *Aedes calopus* are now very scarce near the settlements where the non-immunes live or spend their time.

Attention is also given to movable containers. Whenever any large machinery or new supplies are moved into a district, they are inspected for parts capable of containing rain or other water. It has been found that certain types of tanks on locomotives and parts of certain dump cars hold rain water, and are capable of breeding *Aedes*

308 The Control of Mosquitoes

calopus. Such traveling containers can do much harm, as they may release mosquitoes at many places in a relatively short period. Many types of barges and canal boats contain and retain rain water. On one or two occasions they were known to have transported *Aedes calopus* twenty miles down the coast, from Colon to Porto Bello; adults appeared in large numbers in the settlement adjacent to the wharf to which the barge was tied, and in which this species had been absent for a long period.

Although every precaution is taken to keep yellow fever out, it is always assumed that a case may enter at any time without the knowledge of the health authorities, and precautions are taken accordingly. The light cases known as "walking cases" are the most dangerous type.

In order to keep a record of everyone coming from possibly infected areas, the chief sanitary officer keeps in touch with all infected seaports north and south of the Isthmus. Boarding houses and hotels are compelled to keep a correct register of guests, showing port of departure, and date of arrival of each, so that the history of any case may be rapidly obtained, and non-immunes associated with a case located at once and kept under observation.

Yellow fever is kept out of the Canal Zone and the cities of Panama and Colon by the following measures: Inspection of arrivals, quarantine suspects, and of all who have been less than six days in transit from ports where yellow fever is present, in order to complete the period of incubation of yellow fever under observation. For quarantine purposes this period is considered to be six days. In the ports of Panama-Balboa and Colon-Cristobal the quarantine officers board all vessels, and in addition to the usual examination and quarantine measures, detain those who appear at all likely to be suffering from yellow fever, and also all those who have boarded the ship at yellow fever ports less than six days from the day of the inspection.

The careful exercise of quarantine regulations by vigilant, conscientious, and competent officers makes it unlikely that a case of yellow fever can land in a port, and be allowed to go at large.

The three weak links in the chain are:

1. An unrecognized case, in the early stages, might be allowed to go at large.
2. A person in the early stages of yellow fever might land on the coast from some small vessel, and find his way overland into the Canal Zone, Panama, or Colon. This is possible, but extremely improbable because it would be a mat-

ter of considerable difficulty to find a suitable landing place and then travel overland to some center of population.

3. A ship might touch at a yellow fever port, and either take on a passenger there, and show him, by false entry on a passenger list, as having boarded at another port; or allow some passengers or members of the crew to go ashore for awhile at a yellow fever port, and not make this fact known to the quarantine officers at Colon or Panama. While this would be a dangerous thing for the commander of a ship to do, one such case occurred at Colon. A ship of a well-known steamship line touched at a certain yellow fever port before coming to Colon. At Colon the captain subscribed to the statement that no one was allowed ashore while the ship remained in the yellow fever port. This statement was accepted by the quarantine officer at Colon, and the passengers allowed to land.

Among the passengers was a young Englishman. Four days after his arrival he had an attack of yellow fever. Eight days later he was taken to Ancon Hospital where he died on the thirteenth day of the disease. Before he was taken to the hospital, throughout the period of infectibility, he lived in an apartment house in the city of Panama,



A short length of eave trough used over a doorway

boarded in a hotel, and mingled freely with people, many of whom were not immune to yellow fever. After the patient's removal, the usual precautions of fumigating were taken in the house in which he resided in Panama, as well as the house where he visited his sister, her boarding house, and a factory in which he had worked a few days. No other cases developed, because absolute reliance is not placed on quarantine alone, but on quarantine service supplemented by continuously sustained efforts for *Aedes calopus* destruction, which is the second and most important line of defense.

As means of prevention of the reintroduction of yellow fever the following measures are adopted:

Each house, garbage dump, cistern, well, water barrel, water-jug (*tinaja*), and other breeding places of *Aedes calopus* are inspected at least once a week.

Breeding places that can be destroyed are immediately abolished, or notices are served upon the owners to destroy them within twenty-four hours.

Wells, cisterns, water barrels, etc., which are more or less permanent, are protected against mosquitoes by screening with mosquito-proof metal screening.

Troublesome eave gutters are cared for by

312 The Control of Mosquitoes

frequent inspections to detect sagging, etc., which tends to collect water. In practice it was almost impossible to maintain existing roof gutters on private residences in a self-draining condition except those placed over entrances and not exceeding eight feet in length.

From time to time a wooden vessel holding a little clean water is exposed in a position convenient for ovipositing. The vessel is observed daily for a week or two to detect the presence of larvæ in a given locality and reach a fairly definite conclusion regarding their presence or absence.

The methods adopted to keep the number of *Aedes calopus* on the Isthmus below the infective minimum and the results that have been accomplished are due to the thorough and painstaking application of now well-known measures. It has been asserted that the eradication of such a prolific insect species as the *Aedes calopus* is impossible. The senior author believes it possible; but for the practical purposes of the prophylaxis of yellow fever, entire eradication of *Aedes calopus* is desirable but not a necessity. What is needful, is to keep their number in a given locality below that required to propagate the disease. It is difficult to determine what this number is. It would differ according to the number of fever cases

present; to the efficiency of the measures taken by quarantine for the exclusion of yellow fever; and to local conditions of housing. Each locality must establish its own rules in this respect.

Discussion has arisen at intervals regarding the advisability of destroying water-holding plants such as banana, alocasia, etc. We are inclined to believe that danger from these plants has been greatly overestimated. It is possible that larvæ of *Aedes calopus* may have been found in them, but careful observation in Cuba and on the Isthmus has convinced us that fully developed larvæ or pupæ of this species seldom occur in these water-holding plants, and that the banana plants are unimportant in producing them. The destruction of ornamental and useful plants causes opposition and we would urge that, before the wholesale destruction of these plants is undertaken, very careful observations be made to determine their true importance in the propagation of this mosquito.

CHAPTER VII

THE VALUE OF YELLOW FEVER ERADICATION IN THE CONSTRUCTION OF THE PANAMA CANAL

ASIDE from the humanitarian aspect, the value of the work lies in its practical aid to the problem before the people of the United States: the construction of the Panama Canal. Was the eradication of yellow fever essential to the solution of the problem of digging the canal?

In reply three points must be considered:

First, the loss of employees through the mortality of yellow fever.

Second, the effect of the presence of yellow fever on the morale of the corps of employees.

Third, the effect of the presence of yellow fever on the canal on the attitude of the people and press of the United States and other nations towards the canal construction.

The average number of employees on the canal

has been about 40,000, practically all of whom are non-immune. Their families residing on the Zone and in Panama and Colon would add approximately as many more. If the yellow fever rate of the French company's employees is used as a basis for estimating the probable yellow fever mortality among the canal employees between 1905 and 1915 a mortality of about 1400 per annum among the employees would not err on the side of exaggeration. To this should be added at least an equal number for the employees' families, were their families there. At this rate, during the ten years estimated for the completion of the canal, mortality from yellow fever would reach the frightful total of 14,000 employees,—300 deaths for each mile of the canal. Even this estimate is based on the assumption that yellow fever increases in direct ratio with the increase of non-immune population, and that the number of cases of yellow fever progresses along a definite level, while in fact, the curve of yellow fever ascends much more rapidly than the curve of non-immune population; as knowledge of the mode of the transmission of yellow fever would premise.

It is impossible to estimate even approximately the probable mortality from yellow fever had its devastation been left unchecked.

The effect on the morale of the employees. The presence of yellow fever in a community has a peculiarly depressing effect upon the non-immune inhabitants. Yellow fever is one of the diseases for which the human race may be said to have an inherited phobia. It is well known that in 1904-1905 special inducements were required to secure desirable men for work on the canal and even many of these soon left. We can testify from personal experience to the panic which cases of yellow fever occasioned among the American employees, many of whom returned to the United States within a few days after arrival, frightened away by the presence of yellow fever. It is obvious that the class of men who go to a yellow-fever-ridden country might not be the best from an economic point of view.

The effect on the people and press of the United States, etc. The bulk of the laborers were recruited from Barbadoes, Jamaica, Trinidad, Spain, Italy, and Greece. Would these countries have permitted the emigration of a large number of their non-immune citizens to a country where yellow fever was rampant? Witness the action taken by these governments to prevent emigration to the Manaos region, and Brazil region. The skilled labor, professional and clerical employees,

are American. Many people in the United States regarded the project, if not with hostility, then with indifference. The general mental attitude was that of judgment reserved, but with an underlying expectation that for one reason or another the Canal might not be completed. With several hundred cases of yellow fever among the employees, how long would the people of the United States have countenanced the construction of the Canal *at such a price?* We think that had the method of yellow fever transmission not been discovered before 1904, and had it been impossible to eradicate it from the Isthmus, the Panama Canal would not be completed, as anticipated, in 1914.

Nor should another phase be forgotten. The work accomplished in Panama proved to the world the possibility of eradicating yellow fever from any locality where the work is properly conducted. Colonel Gorgas expressed his opinion regarding the eradication of yellow fever as follows:

I look forward in the future to a time when yellow fever will have entirely disappeared as a disease to which mankind is subject, for I believe that when the yellow fever parasite has once become extinct, it can no more return than the dodo or any other species of animal that has disappeared from the earth.

318 The Control of Mosquitoes

At what cost can this work be accomplished? Many factors must be taken into consideration before even an approximate estimate can be attempted. The size of the community; the geographical and topographical features; the meteorological data; the character of the water supply; the method of sewage and refuse disposal; the architectural characteristics of the dwellings; and the customs and habits of the natives, must all be considered.

If it is desired to permanently rid a city of yellow fever, a complete water and sewer system should be installed, and all houses connected with them, to remove the necessity of having water containers in or near habitations.

It is obvious that the cost of such a system must vary, and depend on local conditions, such as the size of the community, the distance from available water supply and sewage disposal points, the cost of material and labor, etc. It is scarcely fair, however, to charge the cost of water and sewerage system to anti-yellow fever work exclusively, because these systems will benefit the community in many more ways than in aiding yellow fever eradication; some of the most obvious benefits being the reduction, if not the entire elimination,

of water- and fly-borne diseases, of the cost and trouble to the individual householder in obtaining and maintaining a private water supply, and refuse disposal plant, and also in protection from fire with all the gain the last item carries with it in the way of reduced insurance rates, business development, etc.

The cost of maritime quarantine, if necessary in a given community, should also not be charged entirely to anti-yellow fever work. Maritime quarantine will benefit the community in many ways, by excluding undesirables and carriers of various infectious diseases. Only a portion of this expenditure, say one fourth, can be justly charged to anti-yellow fever measures.

Assuming that an anti-yellow fever campaign were to be inaugurated in a city similar to Panama, a city of 40,000 inhabitants, covering an area of approximately one square mile; with a well-marked rainy season of eight months' duration and *Aedes calopus* breeding all the time; with yellow fever foci within six days' travel, and being in constant communication with the city; with no communal water and sewer system, and with yellow fever cases present, the following preliminary organization would be desirable for an anti-yellow fever campaign:

320 The Control of Mosquitoes

Preventive Organization

| | Per Month |
|---------------------------------|------------|
| 1 health officer..... | \$ 300.00 |
| 1 assistant health officer..... | 250.00 |
| 3 clerks..... | 250.00 |
| 8 inspectors..... | 1,000.00 |
| 10 foremen..... | 350.00 |
| 100 laborers..... | 2,500.00 |
| 7 wagoners..... | 225.00 |
| | <hr/> |
| | \$4,875.00 |
| 7 wagons..... | \$ 250.00 |
| 14 mules..... | 2,000.00 |
| 14 sets of harness..... | 450.00 |
| | <hr/> |
| | \$2,700.00 |

Material necessary: Ladders, sulphur, pyrethrum, alcohol, paper, one-inch strips of wood in lengths of six to twelve feet, tacks, tools, oakum or cotton waste for calking, canvas for tentage, cords, pans for fumigation, brushes for pasting, flour for paste, scrubbing brushes for removing the adherent paper, soap, wire gauze, spigots, and barrel tops.

The hospital organization: A fifty-bed hospital of small wards preferably. Double-screened vestibules, with the doors arranged so that only one door can be opened at a time and a watchman constantly on duty to see that both doors are

never opened at the same time. The hospital personnel should consist of:

| | |
|--------------------------------|------------|
| 2 physicians..... | \$450.00 |
| 15 nurses (1 chief nurse)..... | 1,100.00 |
| 25 orderlies, etc..... | 400.00 |
| 1 druggist..... | 150.00 |
| 1 clerk..... | 125.00 |
| 2 cooks..... | 100.00 |
| 1 ambulance driver..... | 50.00 |
| | <hr/> |
| | \$2,375.00 |

1 ambulance with appurtenances.....\$1,200.00
 Subsistence of patients at \$1.00 per day per patient.

The Quarantine Organization

| | |
|---|--------------------------|
| 1 quarantine officer..... | \$ 300.00 |
| 1 assistant quarantine officer | 250.00 |
| 1 launch engineer..... | 75.00 |
| 1 launch hand..... | 30.00 |
| 1 custodian of quarantine station..... | 125.00 |
| | <hr/> |
| | \$ 780.00 × ¼ = \$195.00 |

and the necessary attendants, waiters, etc., required for the detention house, which should pay a considerable portion of its maintenance from the fees collected from the passengers.

Calculating the cost of this organization on the basis of salaries paid in Panama by the United

322 The Control of Mosquitoes

States, the cost chargeable to the anti-yellow fever campaign would be as follows:

For salaries and wages about \$7500 per month.

For material, etc., \$3000, inclusive of cost of maintenance of hospital and one quarter the cost of the maritime quarantine, but not including that of water and sewer installation.

The campaign in Panama lasted approximately fourteen months. It is the opinion of the chief sanitary inspector, who conducted the campaign, that this time could have been reduced to six months had supplies been more readily available, together with active coöperation on the part of the civil authorities. Assuming that the preliminary work could be completed in nine months, the cost of the

| | |
|-------------------------------------|-------------|
| Preventive Organization would total | \$57,400.00 |
| Hospital Organization would total | 34,875.00 |
| | <hr/> |
| | \$92,275.00 |

After this period, only a small fraction of the time of the health officer and his organization need be given to anti-yellow fever work, and the organization could be reduced or its activities directed into other channels.

The hospital could be converted into a general

hospital, or closed. The quarantine organization should remain permanent.

It is to be understood that the figures given are merely approximate, and based on the cost in the city of Panama. This estimate is subject to wide variations under varying local conditions.

Yellow fever was eradicated in towns in Cuba without the installation of sewer and water supply. In the absence of these conveniences, it will depend upon the conscientious work of those in charge of the mosquito-control campaign whether fever will be reintroduced. At Santiago de las Vegas, Cuba, a town of about 10,000 inhabitants of which ten per cent. were non-immunes, yellow fever was eradicated and mosquito breeding places eliminated within three months at a cost of less than \$5000.

In that case the chief sanitary officer was well supported by the governor and town officials.

In 1911, in reply to a question relating to the world's greatest events, the Right Honourable James Bryce, Ambassador to the United States, said: In modern times most of the events of highest ultimate significance have been discoveries in the realms of nature or inventions in the realm of industry; and their magnitude is seldom known at first. Little was said of the discovery that

324 The Control of Mosquitoes

mosquitoes are the carriers of yellow fever and the intermittent fevers, yet what immense consequences are already seen to flow from the determination of that fact!

INDEX

- Acetylene lamp for mosquito catching, 91, 211
- Aedes calopus*, biting experiments, 234
- biting habits of, 304
 - collection of dead, 241, 277
 - container breeders, 55, 240
 - control of, 235
 - detection of, 312
 - eradication of, 234, 241, 291, 312
 - flight of, 234, 242
 - habits of, 234, 240
 - infection of, 245
 - larvæ, habits of, 263
 - period of incubation, 235
 - time of biting, 274
- Agramonte, Dr., experiments in Havana, 231
- Algæ, copper sulphate applied to, 45
- larvæ found in, 47
 - matted with crude oil, 61, 71, 170
 - penetration by larvæ, 65
 - protect larvæ, 26, 65, 180
 - rapid development of, 26
 - retards currents, 60
 - warmth increases growth of, 65
- Ancon Hospital, before 1904, 16, 18
- mortality statistics, 265
 - preventive measures adopted at, 283, 287
- Anopheles*, avoidance of light by, 22, 51, 84, 94
- Anopheles*, biting experiments with, 21, 46, 89
- biting in sunlight, 78, 90
 - in brackish water, 74
 - carriers, animals, 92
 - — boats, 308
 - — cars, passenger and freight, 92
 - — travelers, 50, 51, 92
 - caught after staining, 114
 - characteristics of larvæ, 5, 222
 - collection of larvæ and pupæ for laboratory, 45, 46
 - in cracks of hydraulic fills, 120
 - deprivation of air, 152
 - destruction by hand, 52, 186, 202, 208, 220
 - evaporation fatal to, 46
 - flight, against the wind, 95
 - — at Gatun, 76, 98
 - — long distance, 47, 96, 98, 100
 - — in relation to rainfall, 38
 - — time of, 188
 - hiding places of larvæ, 62
 - in hospital wards, 20
 - hours of biting, 21, 85, 89, 224
 - identification of larvæ, 48
 - lack of data concerning, 43, 44, 73
 - larvæ, methods of detection of, 78
 - long distance transportation, 50, 92

- Anopheles*, methods of staining, 110
 — prevalence of, before sanitation, 20
 — prevalence of, at Gatun, 1913, 98
 — propagation areas, 43, 64
 — sheltering habits, 86
 — time of collecting on screening, 51, 213
 Anophelines of the Canal Zone, 51
 — habits of, 47, 91, 196
 — persistence of, 52, 204
 Ants, natural enemies of mosquitoes, 186
 Apparatus to register flight of mosquitoes, 108
 Aquatic insects, natural enemies of mosquitoes, 185
 Aquatic plants, 10, 40, 97, 129, 182, 190
 — change in character of, 190
 — in Gatun Lake, 99
 — protect larvæ, 40
 — reduce stream flow, 10, 29
 — reduce surface velocity, 10
 Army Medical Board, conclusions of, 233, 235
- Bath, Mr., mosquito trap, 216
 Bats, natural enemies of mosquitoes, 188
 Bermuda grass, 193
 Birds, natural enemies of mosquitoes, 188
 Birds, "night-jars," 102, 104, 106, 188
 Birds, water-fowl, 41
 Blood samples, taking of, 18
 Boats as carriers of malaria, 308
 Boats, for clearing rivers, 64, 196
 — flat-bottomed, for oiling, 168
 Borrow-pits (*see* fills)
- Breeding places, of *A. albimanus*, 47
 — in borrow pits, 70
 — clearing promotes evaporation of, 195
 — crab holes, 72
 — excavations, 40, 70
 — puddles, 25
 — railroad tracks, 38
 — rivers in dry season, 64
 — stream-beds, 62, 63
 — streams on steep hillsides, 25
 — temperature of water in, 72
 Bryce, Right Honorable James, 323
 Busck, A., of Smithsonian Institute, 44, 53
- Cages, for *Anopheles* transportation, 46
 — for fumigation tests, 252
 — for immersing larvæ, 50, 152
 — screened, for yellow fever patients, 288
 — for staining *Anopheles*, 110
 Campho-phenique (*see* Fumigants)
 Camps, near Bas Obispo River, 183
 — selection of sites, 226
 — for troops in tropics, 220
 "Canal Building," screening of, 282
 — yellow fever focus, 280
 Carroll, Dr., experiments in Havana, 231
 Cars, screening of, 203
 Carter, Dr. H. R., observations on time of incubation, 231, 235
 Case histories, 300
 — to determine sources of infection, 244, 308
 — Panama, 285
 Catch basins in sewers, 157

- Chloroform tube for mosquito catching, 91, 211
 Clothing for rainy season, 81
 Collecting *Anopheles* larvæ and pupæ for laboratory, 45
 Colombia, lack of sanitary organization, 264
 Concrete (*see* Ditches)
 Containers, the breeding places of *Aedes calopus*, 55, 240
 — dregs in, 263
 — experimental wooden, 312
 — flower-pots at Ancon Hospital, 18, 263
 — hidden, 241, 280
 — mosquito producing in Havana, 237, 240
 — mosquitoes disappear on removal of, 290
 — movable and traveling, 307
 — resembling natural breeding places, 55
 — in rubbish heaps, 263
 — screening of, 311
 Coral formation, 7, 269
 Costs of Canal Zone prevention measures, 220
 Crab holes, 72
 Culverts (*see* Drainage)
- Darling, Dr. S. T., biting experiments by, 46
 — identification of larvæ by, 48
 — studies of Isthmian *Anopheles*, 45
 Diary, station, 307
 Ditches, alignment of, 146
 — branch, 126, 134, 141, 143
 — comparative cost of linings, 137, 145, 148
 — concrete lining, 136
 — conditions producing mosquitoes, 71
 — cost of spoiling grade, 147
 — factors in construction of, 149
 — fieldstone lined, 19
 — Ditches, grading of, 126, 128, 132, 134, 147
 — herring bone, 7, 126
 — on hydraulic fills, 120
 — inspection of, 129, 144, 145
 — intercepting, 9, 16
 — key walls, 140
 — location of, 125, 196
 — maintenance of, 125, 144
 — cost of maintenance of, 15, 137, 145
 — masonry lined, 17
 — narrow bottomed, 125
 — natural water-courses, 149
 — near seepage outcrops, 136
 — open, 125, 129, 130, 136, 149
 — permanent lining of, 8, 137
 — pot-holes in, 61, 125, 128
 — regrading of, 130
 — reinforced concrete lining, 15, 138
 — reinforced concrete lining, cost of, 138
 — scouring of, 128, 130
 — slope of, 125, 136, 138, 140, 144, 148
 — soft bottomed, 56, 148
 — storm water, 127
 — in truck gardens, 11
 — undermining of, 41, 143, 144, 146
 — width of, 123, 143, 148
 — weep holes in, 136, 139, 141
 Dragon flies, 185
 Drains, outlet of intercepting tile, 135
 Drains, storm water, 127
 "Drainage, *Anopheles*," requirements for, 125
 Drainage, badly planned, 124
 — channels, blocking of, 39
 — in coral formation, 7
 — culverts, 41, 70, 150
 — use of dynamite in, 118
 — grade, change of, 131, 149

- Drainage, grade, to fit topography, 141
 ——— flatness of, 72, 125
 ——— steepness of, 128, 132
 ——— taking levels for, 126, 132
 ——— open, 125
 ——— pipe lines for, 149
 ——— subsurface, cost of maintenance, 134
 ——— tile, 130, 132
 ——— intercepting tile, 131, 134
 "Drips" (*see* Oil)
- Eave-troughs, 262, 289, 311
 Employees, mortality of, 314
 Enamel-ware saucers and dippers, 45, 79
 Evaporation of cleared spaces, 12, 195
 Excavations, 70
- Fills, on absorbent ground, 115
 ——— borrow pits for, 116
 ——— heavy, 118
 ——— hydraulic, cost of, 121
 ——— cracks in, 119
 ——— filling cracks in, 120
 ——— shallow ditches on, 120
 ——— porous material for, 116
 ——— settling of, 39
 ——— shallow, 116
 ——— vegetation on, 118
 Fines, sanitary regulations, 239, 275
 Finlay, Dr. Carlos, theory of yellow fever transmission, 231, 235
 Fire, clearing by, 197
 ——— danger from stored oil, 165, 171
 ——— precautions in fumigation, 248
 Fish, Barbadoes, 185
 ——— used after clearing and training, 10
 ——— notes on, 64, 184
- Fish, small, cannot penetrate algæ, 65
 ——— value as eradicators of larvæ, 182, 191, 194
 ——— value as eradicators in New Jersey, 185
 ——— in wells, 8
 Flight, apparatus for registering, 108
 ——— solution for registering, 108
 ——— (*see* *Aedes calopus* and *Anopheles*)
 Floating islands, drifting of, 99, 194
 Fomites, yellow fever, 233, 236
 Foot-prints, holding water, 60
 Formula for drip oil, 159
 ——— Panama larvicide, 174
 ——— pumping oils, 167
 ——— stain, 111
 ——— stain testing solvent, 111
 French occupancy of Canal Zone, statistics, 23
 ——— villages and camps, 17
 Fumigant, campho-phenique, 254
 ——— formaldehyde, 253
 ——— pyrethrum, 254
 ——— pyrethrum, deterioration of, 253
 ——— sulphur, 254, 300
 ——— tobacco, 253, 254
 Fumigation, action on fruit cargoes, 258
 ——— Ancon Hospital Reservation, 283
 ——— brigades in Havana, 243, 245
 ——— brigades in Panama, 284
 ——— city of Panama, 284
 ——— experiments in Havana, 250
 ——— methods of, 246
 ——— pans, 247, 258
 ——— system of, 236, 244, 252, 286
 ——— tests, 251
 ——— of theater, 303
 ——— uncertainty of, 290

- Fumigation of vestibule at Ancon Hospital, 287
 — after yellow fever cases, 244, 286
- Geography of the Canal Zone, 268
- Gorgas, General W. C., anti-malaria work before 1904, 3
 — appointed by President Roosevelt, 16
 — *Aedes calopus* destruction in Panama, 235
 — on disappearance of yellow fever, 317
 — eradication of yellow fever in Havana, 231
 — Ordinance 6, 273
 — pamphlet, 1906, 265
 — physicians' reports, 243
 — preparations for campaign in Panama, 272, 293
 — rapid selection and delivery of supplies, 272, 273
 — report to General Leonard Wood, 232
 — report on Isthmian Canal, 1904, 261
- Grade (*see* Drainage and Ditches)
- Guard, at door of "Canal Building," 281
 — at door of yellow fever ward, 320
 — at residences of yellow fever patients, 244, 286, 287
- Hand catching, (*see* *Anopheles*)
- Hoof-prints, 19
 — *Anopheles* propagation in, 10, 71, 146
 — difficulty of treating with oil, 56
 — filling, 115
 — of horses with mowers, 197
- Hoof-prints, sanitary regulations, for 57
- Hospital organization, a plan for, 320
- Hotels and boarding houses, sanitary regulations for, 308
- House flies, fumigation effects on, 251
- Howard, Dr. L. O., suggestions and advice in Panama campaign, 44
 — on oil for mosquito destruction, 235
 — writings of, 236
- Hydraulic fills (*see* Fills)
- Infection of *Aedes calopus*, 284
 — from seaports, 308
- Inspection, checking system, 239
 — of ditches, weekly, 129, 144
 — of fumigation, 247, 250
 — house to house for *Aedes calopus* larvæ, 237, 274, 278
 — of houses weekly for *Aedes calopus* larvæ, 276
 — of oil drips, 161
 — of quarantine suspects, 309
 — of screening, weekly, 205
 — systematic, 305, 307
 — system of, in Havana, 6, 236
 — yellow fever campaign, Panama, 274
 — of yellow fever wards, 287
- Inspectors, efficiency of, 59, 305
 — report forms, 238
 — responsibility of foreman, 147
- Jennings, A. H., collections of Zone mosquitoes, 44
- Jungle, cleared from camp and town sites, 195

- Jungle, cleared from abandoned French camps, 22
 — unexplored, 22, 125
- Kendall, on fumigation, 254
- Key walls (*see* Ditches)
- Knab, F., determination of species of Isthmian mosquitoes, 45
- Labor, class allowed Sanitary Dept., in Panama, 298, 299
 — high cost of, prevents progress in the South, 221
 — intelligent, at Havana, 6
 — non-immune, infection of, 39
 — shortage of, in malarial districts, 219
 — transportation of, in ambulances, 246
 — transportation of in covered wagons, 5
 — ultimate cost of infection of, 42
- Laborers, barracks, 213
- Larvacide as a detective, 79
 — Panama, advantages of, 172, 176
 — — cost of, 174, 177
 — — formula for, 174
 — — process of manufacture, 175
 — — toxicity of, 152, 176, 178
 — requirements for, 173
- Larvacides, comparative values of, 151
- Larvæ (*see* *Aedes calopus* and *Anopheles*)
- Lazear, Dr., yellow fever experiments, 231
- Legislation, Panama, 243
- Le Prince, J. A., discovery of mosquito flight, 103
 — report to International Congress of Hygiene, 1912, 95
- Light, effect on mosquitoes, 94, 97, 253
- Light and dark, effect on mosquitoes, 186
- Lizards, 186
- Low, Dr. G. C., observations at Ostia, 198
- Machetes, use of, 195
- Malaria developed by excavation and settling of fills, 39
 — control, effect of topography and climate on cost of, 165
 — control, avoidable costs, 70
 — cost of preventive measures in the Canal Zone, 220
 — effect on labor cost, 219, 221
 — infection, effect of screening on, 206
 — infection of United States agricultural population, 219, 221
 — mortality statistics in Havana, 13, 14
 — mortality statistics, city of Panama, 23, 24
 — in native population, Panama before 1904, 16, 18
 — at old Ancon Hospital, 20
 — parasite, 47
 — pernicious, 8
 — prevents development of the tropics, 42, 220
 — prevention, need for sanitary regulations for, during engineering work, 38, 70, 116
 — rate in the tropics, 219
 — transmission of, 51
 — United States Public Health Service reports, 24
- Materials for a plan of campaign, 320
- Materials, storehouse for, 245

- Monel metal, mosquito wire, 224
 Mortality statistics, city of Panama, 23, 24
 — under French occupancy, 23
 Mosquito bars, 20, 46, 89, 112, 274, 288, 296
 Mosquito catching in dwellings as a prophylactic measure, 202, 208
 — in screened cars, 210
 — destruction in Havana, 236
 Mosquitoes, artificial producing areas, 41
 — biting experiments, 89, 91, 92
 — carried on clothing, 187
 — change of species, 72
 — collection of dead, 250
 — collecting and staining, 112
 — flight observation, 76
 — hiding places of, 36
 — hidden producing areas, 9
 — hours of biting, 21
 — infective minimum, 312
 — Isthmian climate favorable to, 268
 — larvæ, destruction by aquatic insects, 185, 191
 — natural enemies of, 185, 191
 — sudden influx at camps, 155
 — trap for, 96, 214
 Oil, application of, 171
 — rule for application of, 163
 — carts, 168
 — cost of distribution, 164, 165, 166
 — low cost of crude, 153
 — drips, barrels, 159
 — — for heavy and light oils, 160
 — — inspection of, 161
 — — notes on, 154, 225
 Oil drips on rafts, 156
 — — on streams, 155, 156
 — films, 154, 162, 171
 — — breaking of, 71
 — — drifting of, 170
 — — spreading of, 190
 — heavy, inhibits vegetation, 171
 — how it kills larvæ and pupæ, 151
 — and larvacide for pumps, 166
 — methods of distribution, 164
 — pipe lines for, 164
 — spraying, 166
 — tanks, 164, 168
 — viscosity in lower temperature, 157
 Oiling, from boats, 168
 — continuous, 154
 — costs of, 171
 — cotton waste in drip can, 158
 — application by cotton waste, 161
 — drips for light oils, 160
 — intermittent, 162
 — at irregular intervals, 6, 12
 — by "knapsack sprayer," 166
 — methods of, 154
 — precautions for floods, 161
 — simplest form of drip, 158
 — treatment at Havana, 5
 — with watering can, 168
 Orenstein, Dr. A. J., prophylactic value of screening, 206
 Outlet of tile drain (*see* Drain)
 Pack mules, for transportation of oil, 169
 Panama population near endemic sources of yellow fever, 262
 Preventive organization, a plan for, 320
 Pipe lines for distribution of oil, 164

- Pipe for drainage, 149
 — screening entrances of, 149
 Plan of campaign, estimated cost, 321
 Plants, water holding, 72
 Porto Bello, reintroduction of *Aedes calopus*, 308
 Pot-holes (*see* Ditches)
 Potato hooks, to uproot aquatic plants, 192
 Proctor, Mr., mosquito trap, 216
 Prophylactic inoculation of yellow fever, 241
 Pumps for oiling, 166, 168
 Pyrethrum, fumigant, 247, 254
 Pyrocresol, larvacide, 178
- Quarantine, cost of maritime, 319
 — a plan for organization, 319, 321
 — precautions, 308
 — suspects, 309
 Quimby, E. F., apparatus for registering flight, 107
- Rainfall, charts, and topography, 27
 — continuous, effect of, 23, 58
 — continuity compared with volume, 33
 — heavy showers remove larvæ, 11
 — effect of sudden, 61
 — variations of, 59
 Real estate values affected by mosquito control, 3, 10, 121, 319
 Reed, Dr. W., experiments in yellow fever transmission, 231
 Reinforced concrete (*see* Ditches)
 Research required, 69, 223
 Reservoirs, clearing of, 68
 — preparation of sites for, 193
- Rivers, blocking of, 70
 Rivers, mosquito control on the Rio Grande, 64
 Rock, decomposition of, at Culebra Cut, 118
 Roosevelt, President, appointment of Colonel Gorgas, 16
 Ross, Sir Ronald, anti-malaria work in the East, 3, 5
 — *Prevention of Malaria*, 151
- Sambon, Dr. L. W., observations at Ostia, 198
 Sanitary regulations, compulsory reports of fevers in Panama, 285
 — fines, 239, 275
 — hotel and boarding house registers, 308
 — impounding cattle, 57
 — need for, during engineering work, 70, 116
 — Ordinance 6, 273
 — physicians' reports at Havana, 243
 — in Panama treaty, 272
 Santiago de las Vegas, cost of yellow fever eradication, 323
 — eradication of yellow fever, 243, 291
 Screening of cars, 203
 — city of Panama, 277
 — copper gauze, 198
 — crevices in perfectly screened buildings, 204
 — doors, 87, 199, 201, 280, 306
 — imperfect, 204
 — inspection by Health Dept., 205
 — metal, composition of, 199, 207, 224
 — metallic, 206
 — position for doors, 87
 — protection of, 201
 — repairing of, 205, 306
 — of sick-rooms, 244
 — of tents, 203
 — verandas, 199

- Screening vestibules, 201
— water-barrels, 279, 293
— windows, 200
Seasonal changes, effect on
 mosquito production, 44
 68, 72, 81, 112, 126
Seepage, location of, 126
— notes on, 65
— outcrop, Ancon, 19
— — Havana, corrected
 by gravel and cin-
 ders, 8
— outcrops between lines
 of tile, 135
— — covered by vegeta-
 tion, 196
— — on hill side, 37
— — permanent and in-
 termittent, 131
— — on stream banks, 36
— — in unusually rainy
 years, 127
— planes, 116
— sharp changes of grade, 66
Sewerage, catch basins in, 157
—, installation in Panama,
 288
Slapper, for mosquito catching,
 212
Species, change of, *Anopheles*,
 72
— determination of, 45
Spiders, 186
Spraying, methods of, 166
Spray-nozzle, 167
Staining of *Anopheles*, 110
Station, experimental, for ma-
 laria transmission data, 25
Stations, meteorological, 31
Stream-beds, erosion of, 35
Streams, branch, 36
— and drains, blocking of,
 39
— "drips" on, 155
— on hillside, carriers of
 larvæ, 35
— on hillsides, changes of
 source, 62
— as oil carriers, 155, 161
— pot-holes in, 36, 61
Streams, regrading of, 130
— as sources of mosqui-
 toes, 35, 60
— training of, 7, 63, 141
Subsurface drainage, (*see*)
 Drainage)
Sulphur, fumigant, 253, 254
Supplies, importance of rapid
 delivery, 21, 272, 273, 246
— system of preparation,
 245, 246
— — — — — — — — —
 torehouse for, 245
Surveys, preliminary, 16, 22,
 25, 126
Susceptibility to bites, 85, 91,
 93
System of checking inspections,
 239
Tadpoles, 185
Temperature of water, effect
 of, 65, 66, 72
Tent hospitals, 204
Tents, screening of, 203
Tides, low lands near coasts
 affected by, 25, 75
Tides in Rio Grande valley, 75
Tile drainage (*see* Drainage)
Tile drains, inspection of, 135
Tobacco, fumigant, 253, 254
Topography, changes in, 6,
 38, 145
Topography, cause of difficulty
 in mowing, 197
Trask, H. R., cart for oiling,
 168
Treaty, United States and
 Republic of Panama, sanita-
 tion clause, 272
Trees, in flooded areas, 63, 72,
 75, 193
Truck gardens, irrigation of,
 11
United States Public Health
 Service reports, 24
Vegetation breaks oil film, 190
— burning of, 118, 197

- Vegetation, changes in, 182
 — clearing of, from water, 63, 191
 — cutting on edges of streams, 10, 64
 — grass cutting, 295
 — effect of dead, 79
 — on fills, 39, 118
 — inhibition of, 171, 177, 192
 — retards current, 129, 130
 — retards surface velocity, 10
 — on seepage outcrops, 196
 — shelters mosquitoes, 43
 — toxic effect of Panama larvacide on, 177
 — uncut, retards evaporation, 37, 197
 Verandas, screening of, 199, 202
 Vestibule, on houses of yellow fever patients, 286
 — yellow fever ward, 287
 Walking cases (*see* Yellow fever)
 Water barrels, mosquito proofing of, 293
 — impounding of, 150
 — near sewer outlets, 81
 — subsurface, 116
 — supply, effect on yellow fever in Panama, 262, 269, 288, 304
 — in French camps, 17
 — in Havana before yellow fever campaign, 305
 — notes on, 318
 — in towns in Cuba, 323
 — temperature of, in relation to *Anopheles* production, 65, 66, 72
 — velocity of, effect on larvæ, 144, 149
 Watson, Dr. Malcom, report to Royal Colonial Institute, 225
 Wave action, effect on mosquito larvæ, 68
 — ripples break oil films, 163, 170
 Weep holes (*see* Ditches)
 Wells, *Anopheles* in, 55
 — in coral formation, 7
 Wheel-tracks, filling of, 58, 115
 Wind action, loss of fumes by, 259
 — moves and collects debris, 68
 — *Anopheles* travel at right angles to, 105
 — *Anopheles* rest under houses during, 86
 — breaks, 170
 — drying effect on mosquitoes, 46, 113
 — effect on larvæ in lakes, etc., 68
 — evaporation of flat areas, 12
 — velocity of, 86, 90
 Wood, General Leonard, supported mosquito control measures in Cuba, 242
 Yellow Fever Board, Panama, 286
 — a plan of campaign against, 320
 — cases, 243, 275
 — investigation of cases and suspected cases, 283
 — case histories, 300
 — chain of transmission, 292
 — Commission, Cuba, 246
 — cost of eradication, 318
 — effect on emigration, 316
 — effect on morale of employees, 314, 316
 — eradication, 291, 314, 317
 — eradication without sewer and water supply, 323
 — foci, 265
 — fomites, 233, 236
 — history of, 232
 — imported cases, 292
 — infection, 245
 — mortality curves of, 315

- Yellow fever, mortality statistics in Panama, 264
 — old theory of, 304
 — panic, 316
 — parasite, 317
 — period of incubation, 233, 309
 — phobia, 316
 — a plan of campaign with costs, 319
 — prophylactic inoculation of, 241
 — reintroduction of, 291, 311
 — subsidence of, with exhaustion of non-immune material, 267
 Yellow fever, "suspects," 241, 246, 283, 286
 — transmission, 232, 292, 298, 323
 — on United States Cruiser *Boston*, 276
 — "walking cases," 245, 283, 308
 — wards, Ancon Hospital, 287
 Zetek, J., marking and staining mosquitoes, 107, 110

Putnam's Science Series

-
- | | | |
|-----|--|--------|
| 1. | The Study of Man. By A. C. HADDON. | \$2.00 |
| 2. | The Groundwork of Science. By ST. GEORGE MIVART. | \$1.75 |
| 3. | Rivers of North America. By ISRAEL C. RUSSELL. | \$2.00 |
| 4. | Earth Sculpture; or, The Origin of Land Forms. By JAMES GEIKIE. | \$2.00 |
| 5. | Volcanoes: Their Structure and Significance. Revised Ed. By T. G. BONNEY. | \$2.00 |
| 6. | Bacteria. By GEORGE NEWMAN. | \$2.00 |
| 7. | A Book of Whales. By F. E. BEDDARD. | \$2.00 |
| 8. | Comparative Physiology of the Brain, etc. By JACQUES LOEB. | \$1.75 |
| 9. | The Stars. By SIMON NEWCOMB. | \$2.00 |
| 10. | The Basis of Social Relations. By DANIEL G. BRINTON. | \$1.50 |
| 11. | Experiments on Animals. By STEPHEN PAGET. | \$2.00 |
| 12. | Infection and Immunity. By GEORGE M. STERNBERG. | \$1.75 |
| 13. | Fatigue. By A. MOSSO. | \$1.50 |
| 14. | Earthquakes. By CLARENCE E. DUTTON. | \$2.00 |
| 15. | The Nature of Man. By ÉLIE METCHNIKOFF. | \$1.50 |
| 16. | Nervous and Mental Hygiene in Health and Disease. By AUGUST FOREL. | \$2.00 |
| 17. | The Prolongation of Life. By ÉLIE METCHNIKOFF. | \$1.75 |
| 18. | The Solar System. By CHARLES LANE POOR. | \$2.00 |
| 19. | Heredity. By J. ARTHUR THOMPSON, M.A. | \$3.50 |
| 20. | Climate. By ROBERT DECOURCY WARD. | \$2.00 |
| 21. | Age, Growth, and Death. By CHARLES S. MINOT. | \$2.50 |
| 22. | The Interpretation of Nature. By C. LLOYD MORGAN. | \$1.25 |
| 23. | Mosquito Life. By EVELYN GROESBEECK MITCHELL. | \$2.00 |
| 24. | Thinking, Feeling, Doing. By E. W. SCRIPTURE. | \$1.75 |
| 25. | The World's Gold. By L. DE LAUNAY. | \$1.75 |
| 26. | The Interpretation of Radium. Revised Ed. By F. SODDY. | \$2.00 |
| 27. | Criminal Man. By CESARE LOMBROSO. | \$2.00 |
| 28. | Social Evil. By E. R. A. SELIGMAN. | \$1.75 |
| 29. | Microbes and Toxins in Nature. By E. BURNET. | \$2.00 |
| 30. | Problems of Life and Reproduction. By M. HARTOG. | \$2.00 |
| 31. | Problem of the Sexes. By J. FINOT. | \$2.00 |
| 32. | The Positive Evolution of Religion. By F. HARRISON. | \$2.00 |
| 33. | The Science of Happiness. By J. FINOT. | \$1.75 |
| 34. | Life and Death of the Globe. By A. BERGET. | \$1.75 |
| 35. | Genetic Interpretation. By JAMES MARK BALDWIN. | \$2.00 |

THE FLY

Some Important Books on this Subject.

The Subject of the Fly, the Mosquito, and other insects as carriers of disease is receiving more attention at the present moment than it ever has before. Knowledge of recent investigation in this field is essential to every physician in both practice and research work.

Flies in Relation to Disease

Non-Bloodsucking Flies. \$3.50 net. Revised and Enlarged

By G. S. GRAHAM-SMITH, M.D.

24 Plates and 32 Text Figures. (Cambridge Public Health Series)

Flies in Relation to Disease

Bloodsucking Flies. \$3.75 net

By E. HINDLE, B.A., Ph.D.

(Cambridge Public Health Series)

The House-Fly

Musca Domestica, Linn. Its Structure, Habits, Development
Relation to Disease, and Control. \$4.50 net

By C. GORDON HEWITT, D.Sc., F.R.S.C.

With 104 Illustrations and a Map. (Cambridge Zoölogical Series)

House-Flies and How They Spread Disease

By C. G. HEWITT, D.Sc. 40 cts. net

No. 46 of the Cambridge Manuals of Science and Literature

Insolation Hospitals

By H. FRANKLIN PARSONS, M.D., D.P.H.

Formerly First Assistant Medical Officer of the Local Government
Board. \$3.75 net. With 24 Plates and 32 Text Figures

The Bacteriological Examination of Food and Water

By W. G. SAVAGE, B. Sc., M.D., D.P.H.

County Medical Officer of Health, Somerset. \$2.25 net

With 16 Illustrations

Complete Catalogue Sent on Request

G. P. Putnam's Sons

American Representatives of the
University Press, Cambridge, England

H 227 831





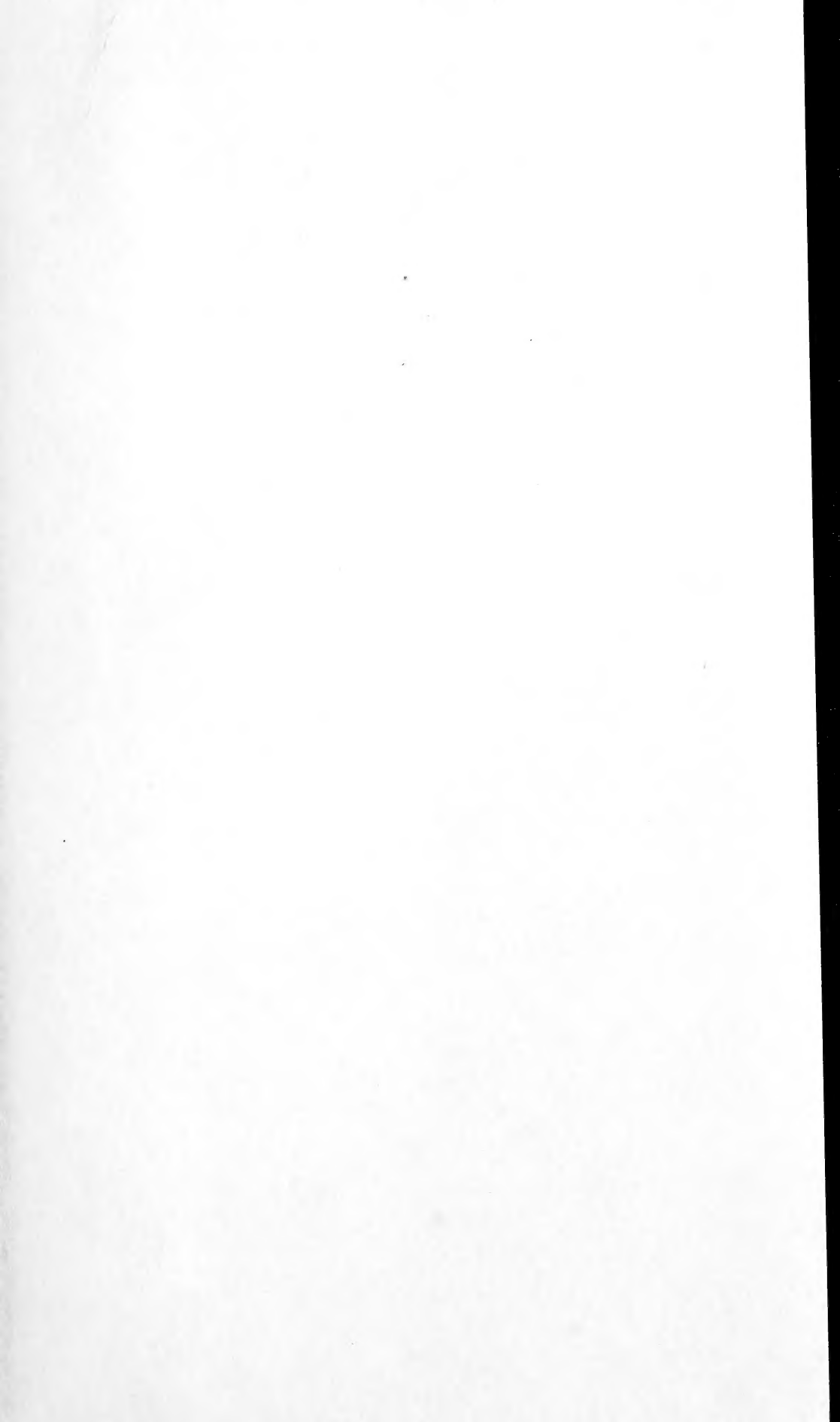

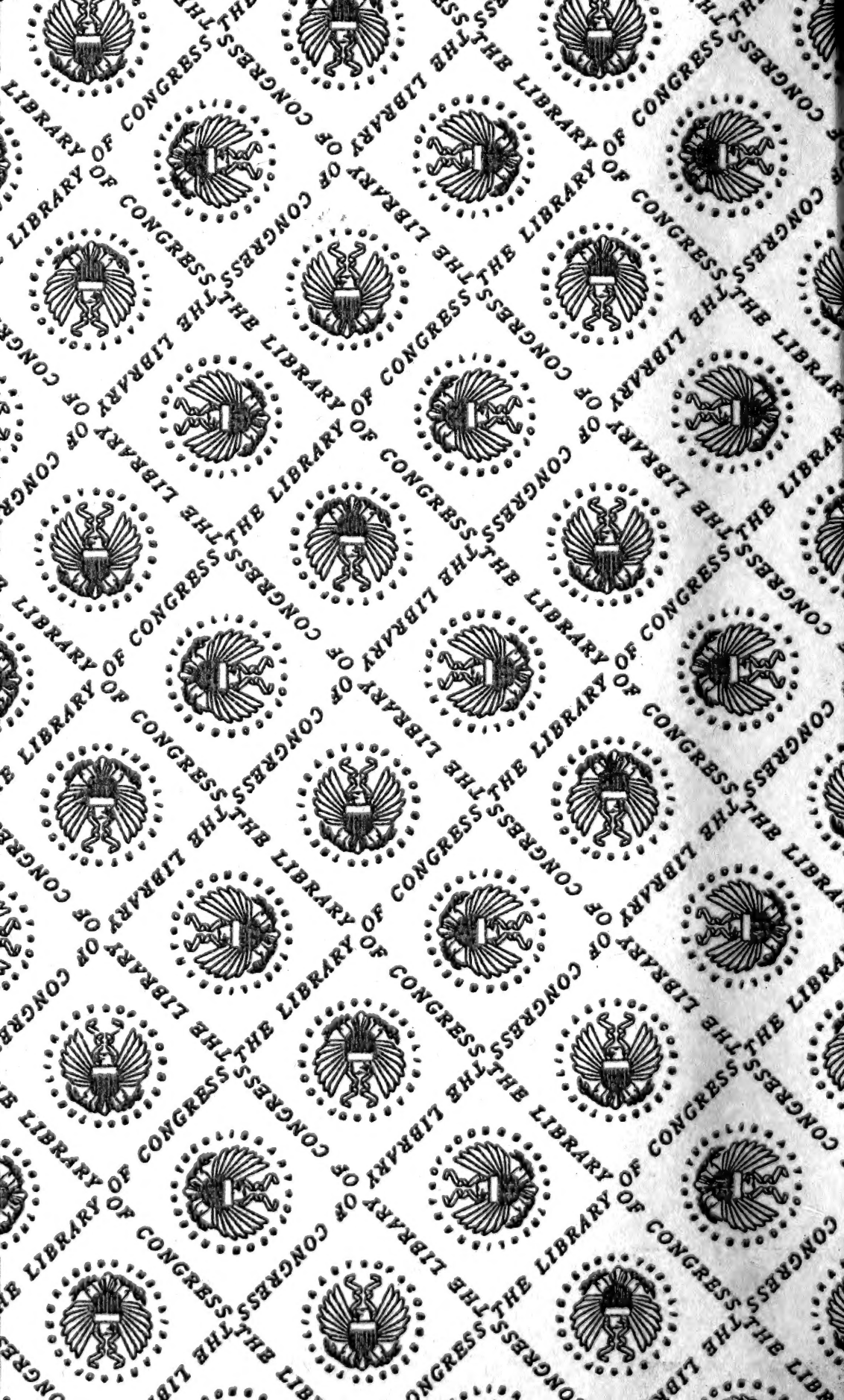

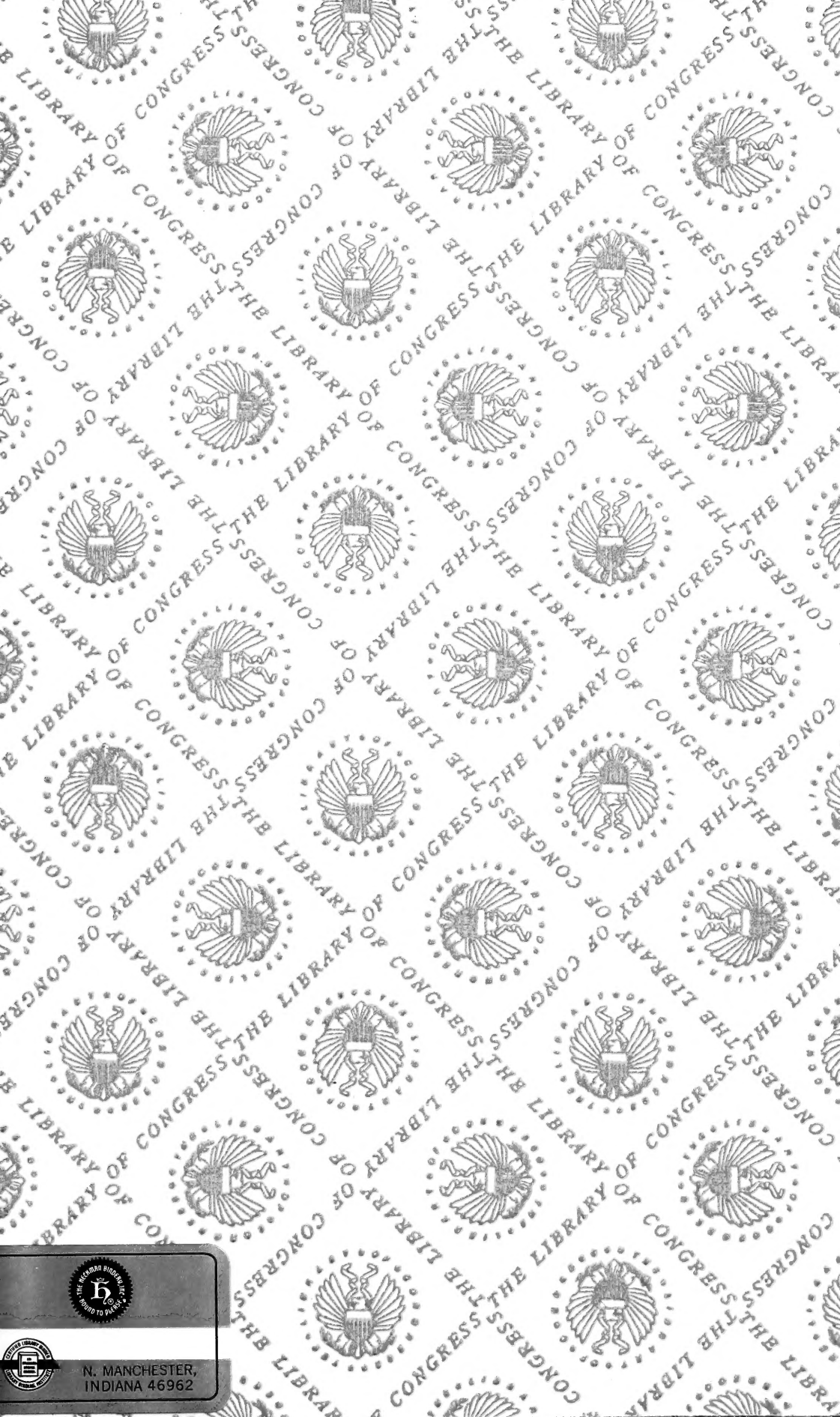

N. MANCHESTER,
INDIANA 46962

LIBRARY OF CONGRESS



0 029 827 962 9