

\$1.00 a Year · APRIL 1909 · 15¢ a Copy

ROD AND GUN

IN CANADA

Sk
1
R6
Vol. 10
no. 11
Cop. 2



W. J. TAYLOR
Publisher ·
TORONTO

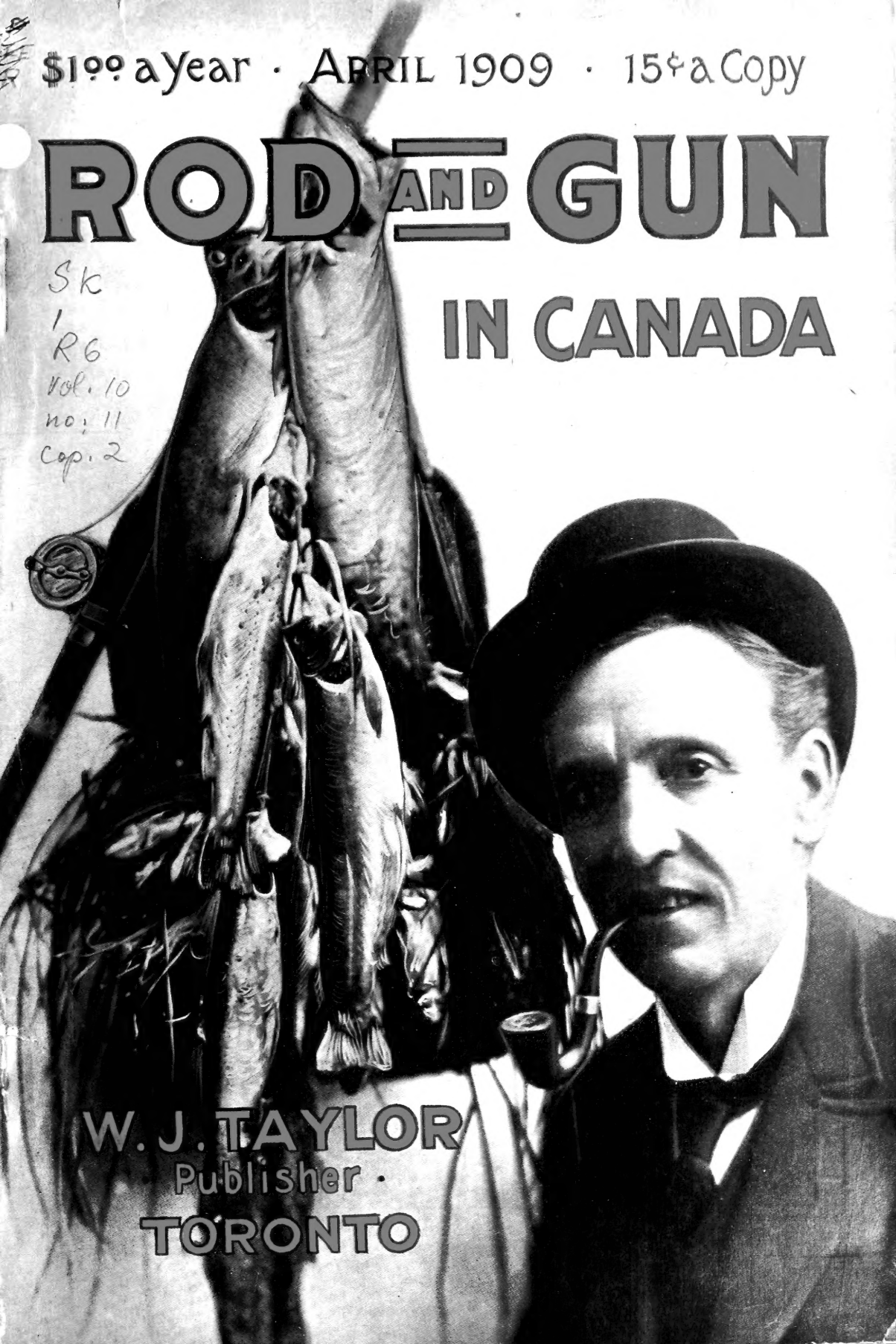

The Red W Combination Wins
First Place for 1908.



96.77%

THE INTERSTATE TRAP SHOOTING
ASSOCIATION'S OFFICIAL SEASON'S
AVERAGE, THE HIGHEST EVER
RECORDED. MADE WITH A

WINCHESTER

Repeating Shotgun and Shotgun Shells

5 out of the 8
first men shot
Winchester Re-
peating Shotguns

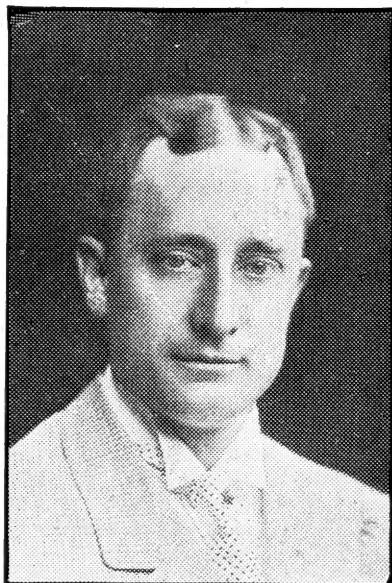

5 out of the 8
first men shot
Winchester
Shotgun Shells

— C. G. SPENCER —

High Average Winner for 1908—96.77% for 11,175 Targets made with a Winchester Repeating \$27.00 grade Shotgun and Winchester "Leader" and "Repeater" Shells, regular stock loads,

THE UNEQUALLED RED W RECORD FOR 1908.

High Average for the Year.
Professional Championship.
Olympic World's Target Championship.

Grand American Handicap.
Target Championship of the World.
7 out of the 10 Interstate Handicaps.

A Handsome Catalogue of FERRO MOTORS

WILL be sent free to those who are thinking of buying an engine or a power boat. It is impossible for anyone to buy a motor intelligently unless he first studies its merits. The merits of the Ferro Motor cannot be set down in the space of this advertisement. Our Catalogue and the 1909 "Treatise" give you the information you want. If you are in the market for an engine get our catalogue at once.

THERE are thousands of Ferro Motors in use all over the world. Twice as many of them were sold last year as any other 2-cycle engine. In all kinds of boats, in all kinds of service under all kinds of conditions, the Ferro gives less trouble, requires less repair, consumes less fuel than any other motor. We want you to know why this is true. Read the Catalogue and get a "Treatise."

The 1909 "Treatise" is the best Guide and Reference Book ever published on Marine Motors.

It tells in simple language and with the aid of more than Three Hundred illustrations all about the construction, installation and operation of marine motors. It is a handsome book, 9 x 12 inches—much larger than editions of former years. It has been compiled by some of the most practical motor and boat experts in the country. The "Treatise" is full of general information which you should have before you buy an engine. It is so expensive that we ask 25c for it—half the cost and postage. Sent postpaid upon receipt of.....

25c

5000 Ferro Specials at a Very Low Price

WE have built a special 3 h. p. motor with all modern improvements, which we sell at a very low price. Making such large quantities we are able to bring down the price and keep up the quality. In every detail this is the best motor that money can build. Latest design, best material and workmanship.

Described fully in our catalogue. Write for it.

The Ferro Machine & Foundry Co.

Wade Building, 816 Superior Ave., N. W.

CLEVELAND, OHIO

New York Address: 44 Cortlandt St., 2nd Floor

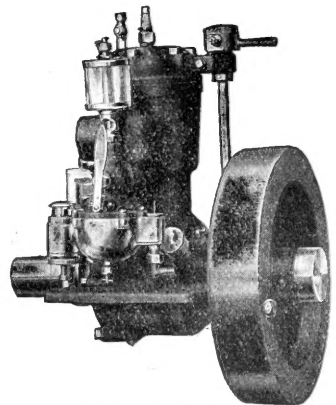

The Ferro Special

Automatic

is the finest and most effective marine engine made

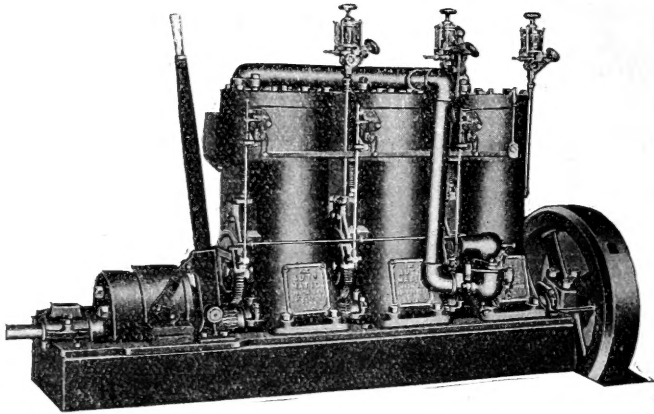

Experienced users of both steam and gasoline engines testify to these facts.

"There is nothing to equal the AUTOMATIC for general good points—everything is so accessible without being in the way, everything seems so carefully thought out to give satisfaction and as little chance as possible for trouble." This is the statement of one satisfied customer.

The record for marine gasoline engines is held by the AUTOMATIC.

The schooner "Sophie Johnson," equipped with an AUTOMATIC, made a trip across the Arctic Circle from Seattle, Wash., to Siberia and return.

The "Sophie Johnson," a 40-ton schooner, equipped with a 3-cylinder 48-h.p. "AUTOMATIC" Marine Gasoline Engine, left Seattle on June 9th and returned Sept. 30th, having covered over 8,000 miles, using both engine and sail all the way. Fifteen days at sea crossing the Behring Sea in heavy storms did not stop the engine once for repair. After returning from Siberia and laying in the harbor for six weeks without any repairing whatever on her engine, she started on another trip to Alaska.

No other build of engine has ever equalled this performance.

THE AUTOMATIC MACHINE COMPANY have always on hand several second hand engines in good order for sale at very reasonable prices.

Launches and heavy duty marine gasoline engines from one to six cylinders, ranging from 6 to 150 horse power.

Write for catalogue to

The Automatic Machine Co.

BRIDGEPORT, CONN.

Canadian Agency: Mianus Motor Works, St. John, N. B.

MOOSE HEADS

We now have to offer some of the finest Moose Heads killed this fall, either mounted or raw. Write us for descriptions and prices. We can quote attractive prices on heads delivered in any part of the world.

ALL HEADS MOUNTED BY OUR PATENT METHOD

Mr. Sportsman or Hotelkeeper, have you not got an old head hanging on your walls that is now an eyesore? Why not send it to us and have it remounted by our new method. Costs moderate and satisfaction guaranteed. Write us anyway and let us quote you.

Taxidermists, amateurs and professionals, postal us for a copy of our Taxidermist's Supply Catalogue.

A good stock of large moose scalps carried. Do you want any?

EMACK BROS.

Taxidermists, Etc.

FREDERICTON, N.B., CAN.

Largest Firm in Canada.

"Wellington"

S. C. P.



The Queen of Gaslight Papers

WRITE FOR PARTICULARS

WARD & CO., "Wellington" Photo Specialties
13 ST. JOHN ST., MONTREAL.

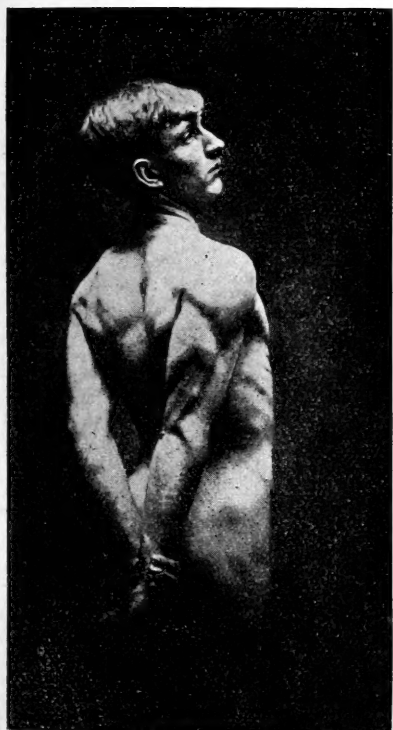

After 14 Days of This System. Age 18.

Canada's Leading Physical Culture System

"Dorchester's"

Pupil writes: "Your system is the surest and quickest extant." Another says: "I am surprised at the quick results." Whilst others say: "A benefit to humanity."

Write for Curative Course, \$10.00, if you have chronic complaints or weaknesses. Send particulars.

Write for Development Course, \$5.00, if you wish splendid muscles with GREAT STRENGTH. Give height, weight, measurements and particulars.

F. E. DORCHESTER

Physical Culture Expert, Regina



— SMOKE —

Van Horne

The highest grade 10 cent
cigar in Canada.

Sold at 10 cents and—by
comparison—worth more.

Harris, Harkness & Co., Makers, Montreal, Que.

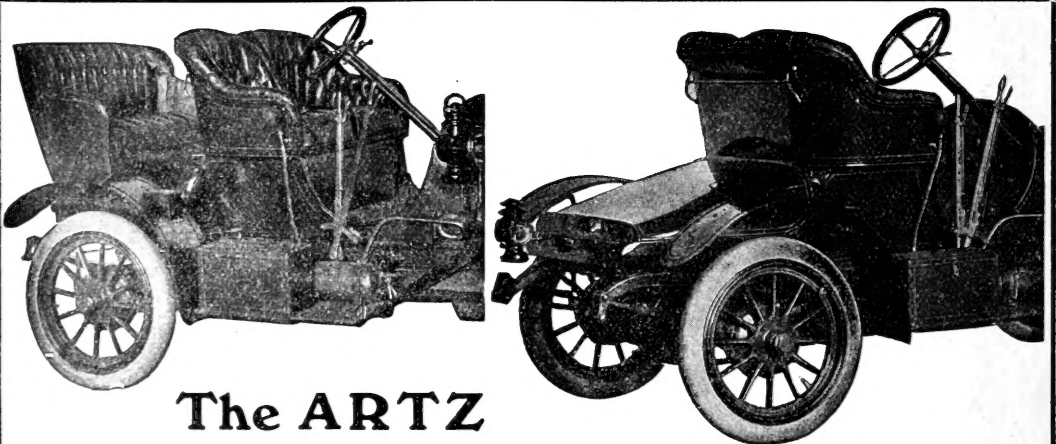

The ARTZ

Folding Tonneau on the MITCHELL RUNABOUT

Opened or closed in 5 seconds without the use of any tools. As firm, strong and comfortable as a standing tonneau.

Also made for Fords, Cadillacs, Buicks and many others.

Write for full description and prices to

DAYTON FOLDING TONNEAU COMPANY

DAYTON, OHIO, U. S. A.

"Empire" Bulk
and
"Ballistite" DENSE
Smokeless Powders

Leaders in the best class of Nitro Explosives

Grand American Handicap, 1908,
Columbus, Ohio, June 23-26

BALLISTITE WINS

PRELIMINARY HANDICAP	-	SCORE	95 x 100
AMATEUR CHAMPIONSHIP	-	"	222 x 240
HIGH SCORE IN STATE TEAM EVENT	"	"	97 x 100

EMPIRE WINS

HIGH PROFESSIONAL IN PRELIMINARY HANDICAP	SCORE	95 x 100
SECOND HIGH SCORE in STATE TEAM EVENT	- - SCORE	96 x 100

AGENTS IN CANADA

Hamilton Powder Co.

Montreal, P. Q. Toronto, Ont. Kenora, Ont.
Victoria, B. C.

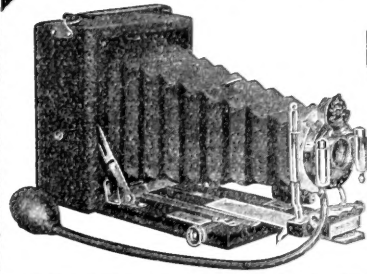

IT'S ALL
IN THE
LENS

Korona Cameras

always represent the highest standard of camera quality. If carefully examined they will win your approbation by their perfection in every detail and the many little features which give them their individuality. Koronas are famous for their lens equipments and they are sold at very reasonable prices fitted with our

TURNER-REICH

Convertible Anastigmat f. 6. 8.
The perfect American lens.

Send for Catalogue

Gundlach-Manhattan Optical Co.
798 Clinton Ave. So., Rochester, N. Y.

National Coils and National Spark Plugs



DASH TYPE.

**Insure Efficiency, Reliability,
Economy and Quality**

The COIL that holds the world's record for non-stop runs, 4,492 miles on Reo Car. Also on the Pilot Car in the New York to Paris race.

Question: Why was the NATIONAL COIL used?

Answer: RELIABILITY.

We are the Makers of the
Reliable National Box Coil.

National Coil Co., Incorporated Lansing, Mich., U. S. A.

Lockwood-Ash Marine Motors

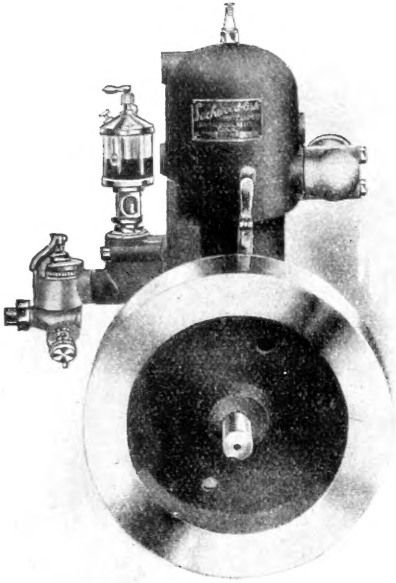

SINGLE CYLINDER TYPE A 2 1-2 H.P.

THE accompanying cuts show our 1-cylinder 2½ H.P. Type A motor, and 2-cylinder 5 to 6 H.P. Type C motor, which are but two sizes of our line.

We build them from 2½ to 25 H.P. in single, double and four cylinders, all two port two cycle.

The best at any price for working or pleasure craft.

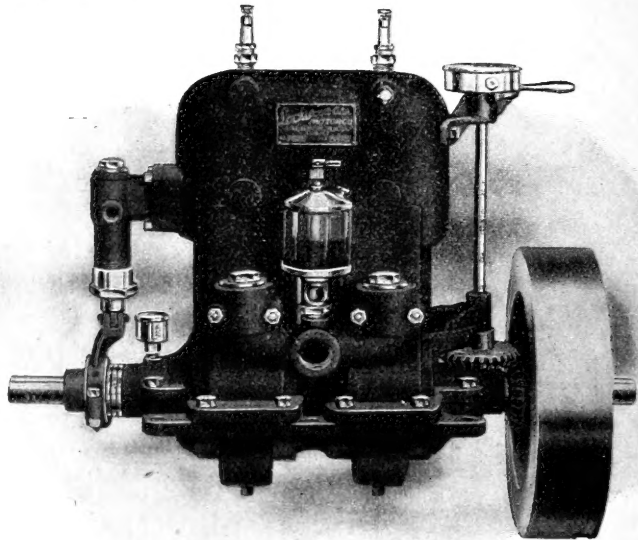

DOUBLE CYLINDER TYPE C 5-6 H.P.

Our new catalogue gives detailed description and may be had for the asking.

LOCKWOOD-ASH MOTOR CO.
Horton Street, Near Main, JACKSON, MICH.

Boats and Frames on the Easy Payment System

Agents
Wanted

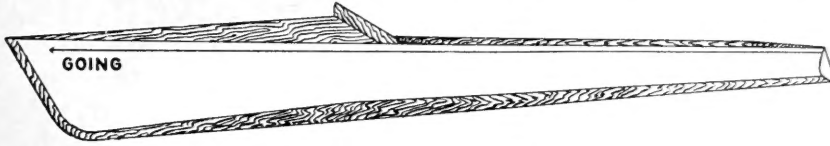

Send for
Catalog

A revolution in Boat Frames and Boats in any stage of construction. My 25 years' experience is at your disposal. State your requirements and the price you want to pay. I'll meet you.

ALF. COWARD
Proprietor

COWARD'S BOAT FACTORY, Kingston, Ont.

"Vulcan Sparker"

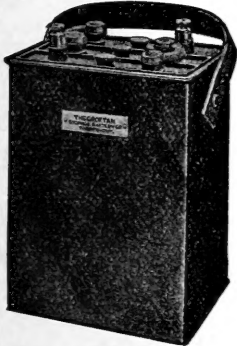

No. 305 Six Volt 70 Ampere

MADE IN CANADA.

Established 1898

"Vulcan" { SPARKING BATTERIES
YACHT LIGHTING and
SPARKING SYSTEMS

Are standard equipment on all high
grade Automobiles and Motor Boats

Over 300 Outfits in use in Canada.

GUARANTEED FOR TWO YEARS

The CROFTAN STORAGE BATTERY CO. 423-425 West Queen St.
TORONTO, CANADA
Montreal and East, John Forman. Winnipeg, Cooper Engine Co.
Vancouver, Vancouver Shipyard, Ltd.

GOOD HEALTH!
DRINK

Bromo Mineral

The well known morning bracer.
Sweetens a sour stomach.

Sold at all Hotels in Canada.

ALSO DEALERS
IN ALL KINDS OF

HOTEL GLASSWARE
AND
HOTEL SUPPLIES.

BROMO MINERAL CO.

86 Church Street, Toronto, Ont.

E. W. DARBEY

Wholesale and Retail Dealer in

Indian Curios
Game Heads
Elk Tusks
Live Animals
Glass Eyes

Official Taxidermist to Manitoba
Government

TAXIDERMIST SUPPLIES

233 MAIN STREET
WINNIPEG, - MAN.

ROSS RIFLES

FOR TARGET AND SPORTING PURPOSES

- "Long range champion, breaks all records, a rifle of wondrous precision"
London Morning Post, July 16th
- "Fine Canadian rifle. Records broken at Bisley."
London Daily Express, July 16th
- "Record Scoring," - - - - *London Daily Telegraph, July 15th*
- "Champion of the year." - - - - *New York Herald, July 16th*
- "Phenomenal performance at Bisley." - - - - *London Field, July 18th*
- "An altogether unexpected and successful appearance
of the new Canadian rifle." - - - - *London Daily Mail, July 15th*
- "Triumph for Ross rifle. Beats all the world's rifles"
London Standard, July 15th
- "Many experts declare the Ross rifle better than new U. S. rifle."
Nottingham Guardian, July 17th
- "An individual triumph. Lee-Enfield hopelessly behind."
London Morning Post, July 15th
- "Achievements at Bisley truly remarkable."
London Evening Standard July 15th
- "Great victory for the Ross rifle from Canada."
London Daily Express, July 15th
- "Great victory at Bisley for the Ross rifle the 'rifle of the future.'
London Times, July 15th
- "A plague of possibles with the Ross rifle."
London Sphere, July 25th

CATALOGUE ON APPLICATION

ROSS RIFLE COMPANY

Quebec

**WHEN IN DETROIT STOP AT
THE TULLER**

Absolutely Fireproof
Cor. Adams Avenue and Park Street

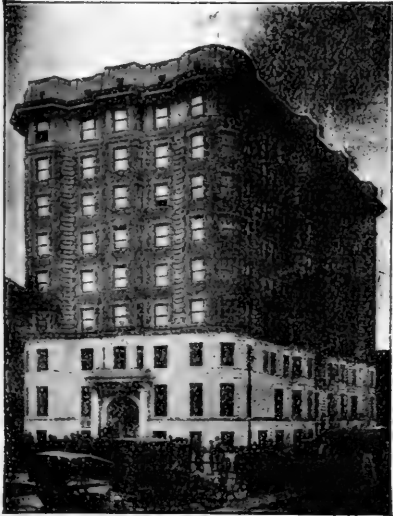

In the centre of the Theatre, Shopping and Business District. A la Carte Cafe. Grille Room. Service Unexcelled. Every Room With Bath. European Plan. Rates \$1.50 per day and up.
M. A. SHAW, MANAGER.



After Shaving

USE

**MENNEN'S
BORATED TALCUM
TOILET POWDER**

and insist that your barber use it also. It is **Antiseptic**, and will prevent any of the skin diseases often contracted.

A positive relief for **Chapped Hands, Chafing**, and all afflictions of the skin. Removes all odor of perspiration. **Get Mennen's**—the original.

Put up in **non-refillable** boxes—the "**Box that Lox.**" Sold everywhere or mailed for **25 cents. Sample free.**



Try Mennen's Violet (Borated) Talcum Toilet Powder. Sample free.

Guaranteed under the Food and Drugs Act, June 30, 1906. Serial No. 1542.

GERHARD MENNEN, Newark, N. J.

\$88.00 SPECIAL



2½ H. P. Engine with patent reversible propeller wheel, 6 feet of shaft with log tube, sleeve, stern bearing, inside stuffing box and reverse outfit complete to install in boat—same engine, with solid wheel and 6 ft. of shaft, **\$78.00** f.o.b. Ithaca. For other sizes write

\$7800 With Solid Wheel

THOMAS & GRANT
ITHACA, N. Y.

U. S. A.

ALL GOODS GUARANTEED

The Glorious Kootenay

Trout and Salmon
Bear, Sheep and Goat
Caribou, etc.

If you wish to have an outing amid the finest scenery and surroundings in America, apply for particulars to

GEO. P. WELLS,

Prop. Hume Hotel,

NELSON, B. C.

NO COLD HANDS

THE ONLY WAY to clean vehicles is with the "Ideal" Carriage Washer. Price of Washer, without overhead, ex. prepaid, \$3.00. Price of Overhead Revolving Hose Arm, ex. prepaid, \$12.00. Fits any hose. Uses any sponge. Order now. Discounts to dealers. Canadian patent for sale. An alluring money making opportunity. Ask for Catalog No. 7.

IDEAL

Ideal Carriage Washer Co., ROCHESTER, N. Y.

Hildreth Marine Motors

Powerful, Economical, Durable
THEY ALWAYS MAKE GOOD.

2
to
25
Horse
Power

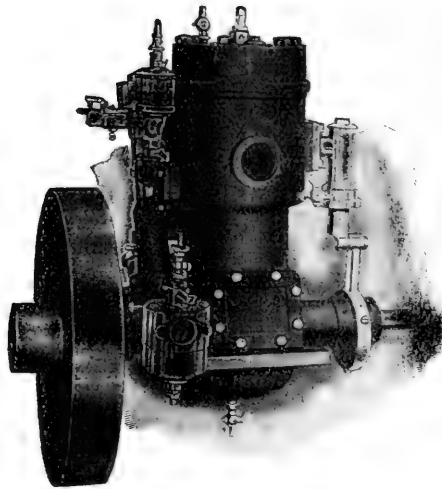

One
Two
Three and
Four Cylinder

The Hildreth Manufacturing Co.
3 Sheridan Ave., LANSING, MICH.

*Write for Catalogue
and Prices*

Manufacturers of high grade
Stationary and Marine Gasoline Motors.

Henry Morgan & Co., Ltd., Montreal, Agents for Province of Quebec
Rice Lewis & Son, Ltd., Toronto, Agents for Province of Ontario

CRUISING AND RACING
GASOLINE LAUNCHES
FULLY EQUIPPED



A VARIETY OF STYLES IN STOCK
FROM 16 to 35 ft. IN LENGTH

Special Light Motor Boats

FOR HUNTING AND FISHING

Hulls furnished, caulked, puttied and painted ready for interior fittings.
Knock Down Frames, Frame and Plank Patterns.
Second Hand Launches.

Send for Catalog

Robertson Bros.

Yards and Launch Works

Foot of Bay St.,

HAMILTON, CANADA.

ROSS CANOES

Our No. 58 is the Prospector's Best Friend

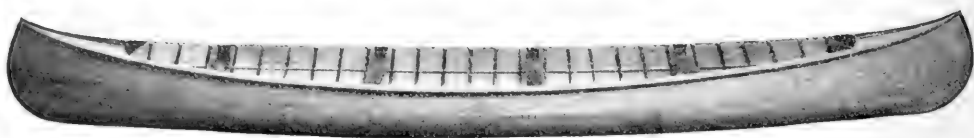

Because they will carry him safely through swift and treacherous waters. Stand hard usage, having an inside keel, which makes them extra strong. They are easily handled in rapids, light to portage, and will carry more ordinary dunnage than can be put into them. Attractive prices. No waiting, can ship same day as order is received.

WRITE FOR CATALOG

The J. H. Ross Boat & Canoe Co.
ORILLIA, ONTARIO

Hotel Winters

Vancouver, B. C.

**A PERFECT HOTEL FOR
PARTICULAR PEOPLE**

Large and New with Every Modern
Convenience
Elevator—Steam Heat
Hot and Cold Water and Telephones
in Every Room
Many with Private Baths

Rates American Plan, \$2.00 up
European Plan, 75c up

FREE BUS

WINTERS & STEVENSON
PROPRIETORS

Prevent Consumption

The way to prevent consumption or ward it off is to get strength to resist it. For strength of tissues and muscles you need Cod Liver Oil. For good rich blood, and plenty of it, you need Iron. For your nervous system you need Phosphorus.

To get the best results take them in

Ferrol
(tasteless)

a scientific combination of all three. It is palatable, and is a blood tissue and strength builder beyond comparison.

Especially valuable in tubercular cases.

Physicians recommend it.

Will be sent, express prepaid, one dollar per bottle, or sold by druggists.

Address

THE NATIONAL FERROL CO.
Buffalo, N. Y., or Bridgeburg, Canada

Try the Saline Waters

OF THE

“St. Catharines Well”

For Rheumatism and Kindred Diseases, and for all forms of Nervous Trouble,
Hydropathic Treatments with Massage, Diet, Rest, Supervised
by Physicians and Nurses.



Avoid the expense of a trip south, try instead the tonic
Influence of
“THE ST. CATHARINES WELL”

Reached by Grand Trunk Railway System
Apply “The Welland,” St. Catharines.

WATERMAN

Marine Motors

Unsurpassed for simplicity, reliability, durability. Few parts.
Easily understood and most reasonable in cost.

Here is Model A

2 cylinder—2 cycle; built with the cylinder and head in one piece; no joints to leak. Cylinders quickly removable. Ignition is jump spark. Plunger pump insures perfect circulation of water in cylinder—can be fitted to use as bilge pump. Can be reversed instantly while running, and runs with equal power in either direction. Equipped with *Schebler Carburetor* and rotary timer and multiple sight feed oiler. Designed for all types of pleasure and commercial boats. Many of these Model A motors have records of 5 years' actual service without calling for one cent for repairs.

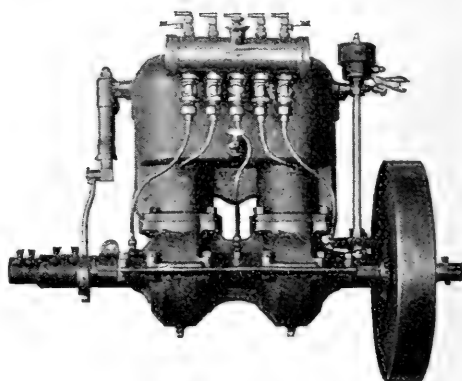

MODEL A

6-8 H. P. 150 pounds

10-12 H. P. 200 pounds

Actual power, not "motor power"

The best motor ever built, quality, equipment and price considered. Every one fully and specifically tested before shipment. Send for **Catalogue A** and learn fully about this dependable motor.

Make a Motor Boat of any Boat in 5 Minutes

And it's no experiment—there's no guesswork about it—neither is there disappointment—simply can't be because the little motor "motes." It is not a toy but a dependable motor. If you've a skiff, row or sailboat, or dinghy, you ought to have one.

A little 2 h.p. marine motor (40 lbs complete), that you attach to the stem-post of your boat in 5 minutes without any tools. Drives an 18-ft. rowboat 7 miles an hour and run 4 hours on 1 gallon gasoline. Can be detached from boat just as quickly and stored in box in which it is carried. Equipped with *Schebler Carburetor*. Simplest motor made—does not get out of order. Four years successful results behind it. Don't be afraid, it will fill your expectations. Send for **Catalog C**.

Waterman Canoe Motors The Waterman Canoe Motor is the only specially designed canoe motor on the market. Made in 1, 2, 3 and 4 cylinders and shipped ready for installation. Send for **Catalog K**.

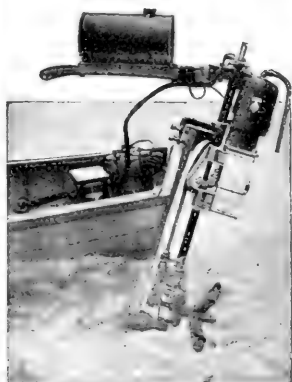

WATERMAN MARINE MOTOR CO.

1519 FORT STREET WEST, DETROIT, MICH., U.S.A.

ROBER MACHINERY CO., Portland, Ore., Western Distributors for Our Products.

Patented 1908 Unbreakable Silk Bound Rod

THE GREATEST NOVELTY IN FISHING RODS

Silk bound, waterproof, Split Cane Rod in Trout and Bass. Strongest rod in the world. Every dealer and fisherman should see this rod. Price is most reasonable and within the reach of all. Made only by us in our factory at Toronto.

The Allcock, Laight & Westwood Co., Limited
78 Bay Street, Toronto, Ontario, Canada

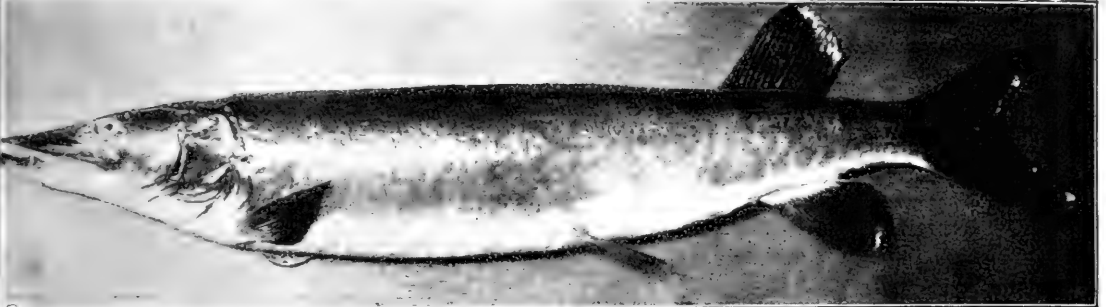

MASKANONGE

Caught by Benjamin Westwood, October 20th, 1908, on the Trent River, with Westwood's Patent Unbreakable Silk Bound 8oz. Bass Rod and Hercules Silk Line No. E. with Live Minnow.

WHY?



Because the Never Miss No. 8 is Guaranteed for 1 year's wear

**No Trouble
No Sooting
No Short Circuits
No Broken Porcelains**

JUST

Real Spark Plug satisfaction and at the price you ought to pay.

**\$1.00 each
Mica \$1.50**

**Don't Wait
Do it To-day
Order a Set**

Your Dealer or Jobber or Direct, Prepaid.

**NEVER MISS SPARK PLUG CO.
LANSING, MICH., U. S. A.**



Steel Fishing Rods

FLY RODS, 8 1/2 or 9 1/2 feet	- - - -	\$ 1.00
BAIT RODS, 5 1/2 or 6 3/8 feet	- - - -	1.25
CASTING RODS, 4 1/2 or 5 feet	- - - -	1.50
CASTING RODS, with Agate Guide and Tip	- - - -	2.50
CASTING RODS, full Agate Mountings	- - - -	3.50



Trout Flies

For Trial—Send Us

18c	for an assorted sample dozen. Regular price, 24 cents.	Quality A Flies
30c	for an assorted sample dozen. Regular price, 60 cents.	Quality B Flies
60c	for an assorted sample dozen. Regular price, 84 cents.	Quality C Flies
65c	for an assorted dozen. Regular price, 84 cents.	Bass Flies

OLDTOWN CANOES

15 and 16 ft.



THE H. H. KIFFE CO., 525 Broadway, New York

Illustrated Catalogue free on application

— HOW ABOUT A —

New Engine for Your Boat?

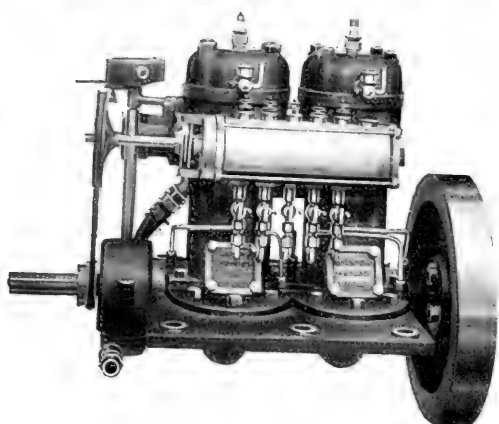

We make them all sizes from $7\frac{1}{2}$ to 60 H.P. This little one is our 8 H.P. Special for 1909. We guarantee it to deliver 8 Brake H.P. at 800 revolutions and it can be run up to 1,100 or 1,200 with a proportionate gain in H.P.

Perfectly Simple
Simply Perfect

Ask about our 6 cylinder light racing engine.

Ask the man who owns one.

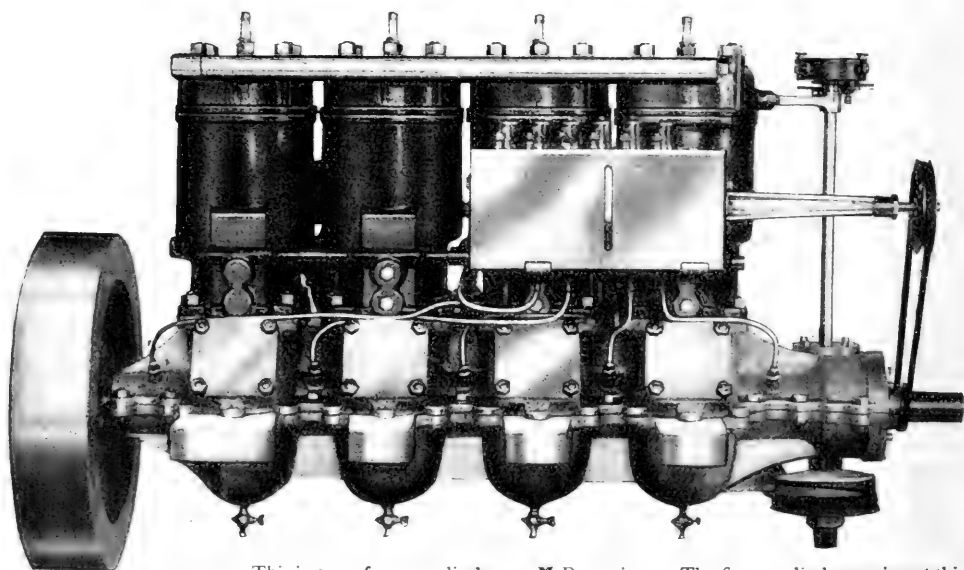

This is one of our 4 cylinder, 30 H.P. engines. The first 4 cylinder engine of this type we built was installed in our fast boat, "Miss Fidgety," which, although not intended for a speed boat, and weighing 3,000 lbs., attained a speed of $21\frac{1}{2}$ miles an hour. This engine has been in hard use for three years. It has never been taken down nor has it had a single piston removed from the cylinders during the three years of its life. We have not spent ten cents in repairs to this engine since it was put together. We can today, turning the fly wheel by hand, show 60 lbs. of compression in her cylinders, which was all we could do the first day she was made.

We build boats to order and test them under any reasonable conditions. There is no cranking with our engines, all that is done in the shop while the engine is being built. We insure you against repair bills. Send for catalogue.

SCHOFIELD-HOLDEN MACHINE CO., LTD.

14 Court Street and 2 Carlaw Avenue, TORONTO, ONT.

Rod and Gun and Motor Sports in Canada

The contents of this magazine are copyrighted and must not be reprinted without permission.

Contents for April, 1909.

Canoe and Pack Strap.....	<i>A. J. Algate</i>	1017
The Moose.....	<i>A. R. Douglas</i>	1022
Preserving the Nation's Fish.....	<i>Cyrus MacMillan</i>	1023
A Fishing Trip up the River Mersey, N. S.....	<i>H. H. Burnaby</i>	1026
The Unsolved Mystery of the Salmon.....	<i>Bonnycastle Dale</i>	1028
A New Brunswick Lost Lake Found.....	<i>Arthur L. Slipp, LL.B.</i>	1032
A Moose Hunt in New Brunswick.....	<i>W. W. L.</i>	1034
The Old Home.....	<i>Dr. Wycliffe Marshall</i>	1036
Bass Fishing in Florida.....	<i>Ezra P. Young</i>	1038
A Quebec Fishing Lake.....		1039
A Day at "the Orifice": Black Bass Fishing in the Cool Waters of the Georgian Bay.....	<i>G. J. Mitchell</i>	1040
A Day in the North Woods.....	<i>Chas. Cameron</i>	1042
A Nova Scotian Fishing Experience.....	<i>Harold B. Whidden</i>	1044
A Derelict.....	<i>Rev. A. L. Fraser</i>	1046
Conservation of Non-Nest Building Fishes of the Great Lakes	<i>W. E. Meehan</i>	1047
Game Protective Work in British Columbia.....		1049
An Interesting Hunting Incident.....		1050
The Big Game of Northern Ontario.....	<i>Jack Miner</i>	1051
Personal Experiences of Two Hunting Seasons.....	<i>R. E. Sparks</i>	1052
Our Annual Fishing and Hunting Trip.....	<i>W. Hickson</i>	1053
Saskatchewan Fish and Game Protective Association.....		1056
Fish and Game Protection in Ontario: A Reply to the Rev. E. M. Rowland.....	<i>Capt. E. H. Kelcey</i>	1057
The Problems of Protective Work.....	<i>Cinna</i>	1058
The Difficulty of Enforcing the Law.....		1060
Another Strong Indictment.....	<i>Wm. Pratt</i>	1061
The Quebec Fish and Game Leases: Hon. C. R. Delvin Banquetted at Quebec.....		1062
Canadian Forestry Association: Important Conferences at Toronto		1064
A Lady's Moose Hunt in New Brunswick.....	<i>Sade M. Emack</i>	1068
Game Protection in Southern Ontario.....		1072
Net Fishing in Ontario Rivers: Strong Objections to Renewal of Licenses.....		1074
The People's Game and Fish Protective Association of Nova Scotia.....		1076
Physical Culture: Laws of Exercise Continued—Baths, etc., No. V.....	<i>Frank. E. Dorchester, N. S. P. E.</i>	1080
Alpine Club Notes.....		1083
Isaak Walton's Will.....		1085
Our Medicine Bag.....		1086
Sports Afloat.....		1097
Automobiles and Automobiling.....		1100
The Trap.....		1112

When Sending Change of Address Subscribers are Requested to Give the Old Address as Well as the New.

Communications on all topics pertaining to fishing, shooting, canoeing, yachting, automobiling, the kennel, amateur photography and trapshooting will be welcomed and published if possible. All communications must be accompanied by the name of the writer, not necessarily for publication, however.

ROD AND GUN AND MOTOR SPORTS IN CANADA does not assume any responsibility for, or necessarily endorse, any views expressed by contributors to its columns. **W. J. TAYLOR Publisher, Woodstock, Ont.**

BRANCH OFFICES: 5 King St. W. Toronto, Ont.
Outer Temple, 223-225 Strand, London, W.C., Eng.

Herald Building, Montreal, Que.
5 Beekman St., Temple Court, New York, N.Y.

Entered Feb. 17, 1908, at the Post Office at Buffalo, N.Y., as second-class matter under act of March 3, 1908



KAMLOOPS TROUT (*Salmo Gairdneri Kamloops*) Jordan.

ROD AND GUN IN CANADA

VOL. 10

APRIL, 1909

NO. 11

Canoe and Pack Strap.

BY A. J. ALGATE.

"I tell you, there's more excitement to the square inch in New York than you'll get in a mile of your north country." The words reached me through the open doorway of Jay P's room as I mounted the stairway to his attic abode one stormy night last winter. Outside, the fine dry snow-dust swirled in spiteful gusts, and between the rifts the stars shone brilliantly with that steely glint premonitory of a further tightening of winter's grip,—just such a night to make one truly appreciate the kindly warmth of a good fire. The voice was not Jay P's, I knew,—he was too good a woodsman to speak thus—and as I passed into the cheery glow of the den, I found the speaker crouched before an open grate as if to coax further warmth from its bright blaze. The face was sallow, the eyes dull, the cheeks sunken,—his whole carriage bespoke fagged out manhood, and as I gripped the soft flabby hand in a cordial shake, he winced visibly under the pressure.

"There's where we differ, Jeffreys," I ventured, "for I've sampled both." "I've been whirled thru the underground tubes of

the Big City to be spewed out at 14th Street for a maddening hour amidst the crowding and the crushing of the big down-town shops,—I've swung round the giddy curves of the 'L' for a morning among the big ships,—I've spent hours at the Bronx watching the restless, rhythmic motions of the caged creatures in the Zoo,—I've taken in all the sights, and after it all was glad, for the mere change, to pack myself into a crowded excursion boat and make pilgrimage to West

Point. Yes, I saw the sights, got some excitement, too I guess, but once was enough. New York's all right for business, but its not the place for a holiday."

Jeffrey's sought to justify his statement, but his scant acquaintance with the northern country was against him, for it extended no farther than fashionable Windermere. Such a vacation he argued meant a broader knowledge of men and things; an extension of friendships; new views of business, and many other things. His very talk stamped him as a man of all work and no play. It was ever business with him, and one wondered



THE AUTHOR.

how long his 'broader knowledge' and 'extended friendships' would be needed in this work-a-day world.

"What weight do you take on?" Jay P. interjected, and Jeffreys had to admit he usually lost, but always 'rested up' when he got back. "Look here, Jeff" he resumed, "just peep into that mirror, will you? Satisfied? No,—hardly expected you would be. I know what's wrong with you, you need to get away from this excitement, and eternal grind of business, get out and breathe some of God's pure air, or else, by George, you'll pay for it before long. Algie's right, this hurry and scurry for fifty weeks in the year, and the same thing, only worse and more of it, for the other two, never sent a man back to his

thought it might interest you." Just at this juncture, the street door banged shut, and Tooky burst into the room simultaneously. "Jimminy crickets, its cold enough to freeze the tail off a brass monkey. B'lieve its worse than that night at Twin Falls, d'y r'member Algie?" Twin Falls was forty miles from nowhere, and the night was that following a day of heavy rain. I had good cause to remember the chilly experience, but to explain would be to anticipate.

Tooky jerked off his coat, beat the air viciously to warm up, and then settled into a heap on the floor with his usual query "what's doin'?" The tale of a past summer's joys and tribulations was finally brought forth and exposed to the scathing and merciless criticism of the trio.

It may be well to explain that we started on Friday, July 13th, despite the attempts of certain superstitious ones to dissuade us. Tooky and myself were alone the early part of the



PACK, TIN SACK, AND TWO WEEK'S SUPPLIES.

desk fit to grapple with big things. The woods for me every time. Why, last summer's trip—and it was a rough one too—gave me eleven pounds, and an appetite that scared the good landlady, and Algie there gained eight. I know how *you* felt when you struck town; sour, clean sour, had no 'go' in you, and nothing was good enough to coax you to eat. I'd cut it if I were you, and try one real trip into the north, then I'll listen to your baby talk about your 'square inch of excitement.'"

Jay P's closing was pure sarcasm, and no doubt hurt, but Jeffreys needed it—and the change too. As he finished, Jay P. turned to fetch his bunch of prints from last year's trip. "I didn't tell you Jeff" he resumed "that Algie wrote things sometimes, did I? He's got a sketch of last year's trip with Tooky, and

trip, but by prearrangement we picked up Jay P.'s party on the down trip.

With misgivings I open the tale: "The shriek of the locomotive and the whirr of wheels had never so near approached harmony as on that night aboard the 'Northland Limited.' It had been a strenuous week of clearing up for the holidays, through the weary season these same sounds had meant nothing but the ceaseless grind of commerce—but tonight they were as the thunder of water or the roar of storm-tossed pine. "Gee" broke in the effervescent Tooky "sounds pretty, don't it, but say, that's just how it felt to me, whenever I woke up." Further comment was interrupted by a cushion shied at him by Jay P. which he skillfully managed to parry, and I resumed "The night mists were making a last futile struggle

against the uprising sun as it swept over the ridges when we swung out from the Pullman, and scarcely had its rays broken clear of the horizon before two paddles beat time to its upward march. Tooky was an old hand at the game, and I had been there before, so that it was not new to either, and as the put in was close to the station, but a few minutes were required to get the canoe into the water and load up with pack, tin sack and two weeks' supplies, about 175 lbs in all.

As the mills of busy Huntsville dropped behind and the isle-bedecked waters of Fairy Lake reached out before us, there came that joyous thrill of freedom, and one's back stiffened to the paddle, sending the canoe along at a merry clip, so

that this pretty stretch was left rippling in our wake before time for morning snack. Just hot tea and a bite to satisfy the inner craving, constituted this meal, then a short paddle through the narrows and across the Peninsula Lake, that little gem of the Highlands, brought us to the portage. It is here at the peninsula portage, that the waters divide and choose the north or south branch of the Muskoka only to re-unite below the falls at Bracebridge enroute to Georgian Bay.

As portages go, this one, five-eighths of a mile in length, is easy, and then it boasts the most unique railway in America, if one chooses to use it instead of the road. That miniature, narrow-gauge, locally termed the "Corkscrew Limited" goes careening across the serpentine stretch of rail like a frightened thing, trailing behind a flat car and a passenger coach, the latter composed of two remodelled tram cars. At Dwight, nestling in the northern arm of Lake of Bays, we leave behind the remnant of civilization, and must now choose between the river, with low water, or a seven mile drive over the portage. We shall have lots of river travel farther on, and so, for once, let us accept this opportunity for a diversion. True, it is but to choose the lesser of two evils, and at

times one wonders how these horses ever maintain a footing on the steep and rocky path. The way these sturdy animals negotiate the last half of this sublime rural roadway, is indeed a revelation to the city bred. Three hours for seven miles is good going, and as we come out at the extremity of the road, there lies before us a beautiful expanse of shimmering water, Octongue Lake. Unlike most lakes, its inlet is on the right shore, and outlet on the left instead of at the extreme ends as is usually found in the narrow deep lakes of this section. Yonder is our camp on the island—we have made a good day's travel and will camp here for the night.

Brr - - r - - r - - grr - - r - w - ow



"THE CORKSCREW LIMITED"

The sounds oozed into a sleepy brain as from a great distance, but suddenly was swallowed in a mighty peal of thunder and I was out of the blankets as though shot. There was Tooky gurgling away to himself as he held up to view a dripping sock. 'Twas scarcely day, the heavy drops spattered angrily against the canvas, drowned momentarily to silence by volleying thunder. The storm was at its height, and we evidently slept through part of it, for as I reached to unclasp the flap the taut canvas gave reluctantly and there at our very 'front door' was a diminutive lake. In our haste the evening before, we had accepted the first convenient spot, and the overflow from our lakelet which formed in the depression at the foot of our tent



A SUBLIME RURAL ROADWAY.

had trickled into Tooky's corner, attracted I alleged by the magnitude of his sizable understandings.

It was scarcely five o'clock, and with the rain still falling we lay there listening to the swish of the great drops on the canvas and the thunders reverberating among the distant hills. By six-thirty there were signs of clearing, and before seven o'clock splashes of gold in the grey eastern sky gave promise of a bright day. Scarcely waiting for our canvas to dry, we made a hasty meal and were off up the lake before the last reluctant storm clouds had surrendered to the rising sun. Joyously we drove our canoe through the water, only to discover after twenty minutes paddle, dead water ahead. We pushed well into the cranberry and shrub in the vain hope of finding an outlet but were forced to retrace our

'steps' and eventually discovered the main channel off the right shore of the lake. To be impatient at such mishaps is not the part of the philosophic wayfarer of the woods, such detours as this are to be expected as part of the day's experiences and are invariably chalked up in the diary as 'explorations.' 'Twas easy to read the promise of a steep portage as we drew into the basin. The waters boiled over a succession of falls (Ragged Falls) while between the water and the portage stretched upward for a hundred feet, the lumberman's skidway or sluice. The climb, though only three hundred yards, is steep, and as we scrambled upward another trail was disclosed sloping down shore, evidently modifying the climb but lengthening the portage.

We pushed out from the eddies above the falls, and at the first bend were greeted with the low rumble of rapids ahead. Plainly here was a case of get out and walk. Tooky went ashore with the tow line and gradually worked up stream while I took to the water. Suddenly there was a lurch from the side and I was swimming for it. The river bed was bad and I had walked into a pitch hole. Fortunately Tooky was alert and the shore was easily gained. This proved but the first of an extended series of chutes, rapids and pitches, which could have been obviated by packing up the lumber trail along the left bank. Our choice was to make the canoe work wherever possible, and when the current proved too strong, we picked the shallows and hauled her behind. Slow work you say, surely, but



WE PICKED THE SHALLOWS AND HAULÉD HER BEHIND.

great fun for one who delights to feel the rushing, gurgling water eddying about his knees and hips. But the trail is good, and safest too.

High Falls portage, the next drop in the river, offers a stiff argument with its rapid, rocky ascent on the left bank (a continuation of the trail above referred to.) Here, one needs his grit and stamina to make this quarter mile at one lift. The trail to the put-in above is winding though fairly clear, and should be followed well up shore to avoid some bad eddies.

It's now past noon and there is a good spot above the falls for dinner. Here we cooked a hearty meal and rested up. Here too it was that we held the 'feast of forty' which will live green in our memories for many moons, and we hope, through many scenes of roughing and exploring in days to come. 'Twas in the down trip, and we had broken camp at Twin Falls some miles above, intending to make time. Rounding corner and curve, we made good progress for a time, leaving behind at every turn, unmolested and peaceful, colonies of fat, sleek frogs, basking in the glorious morning sun. Real frog had not been on the bill



AN EASY TRAIL

for days, and as these settlements slipped by, our resolutions faded into visions of browning, juicy, hind-quarters. All one needs is a quick eye and a ready hand, and we soon had a joyous assortment aboard, varying perhaps twelve to eighteen inches. What! you doubt it? Yes sir, eighteen inches was our best catch, and the proof is on the paddle here. Why, you could cut steaks from that fellow, and his thigh bones were like joints in one's small fingers. Twenty pair of legs, great and small, rolled in flour and cooked to a turn. Ay, a feast of forty, but for two. Ay, may their legs never grow shorter, and may they always choose a lily pad for their morning siesta! Our method of capture may be new to some—but with a sharp eye and ready hand it never fails. Rounding a bend, there in the back water is the inevitable lily garden; we make straight for it, run alongside noiselessly and pick our prize off without even stopping. Even two at a time is possible by a lightning change from right hand to left of first captive. Try it next time, and if you are running in free water, patience and practice will be rewarded by some gratifying sport.

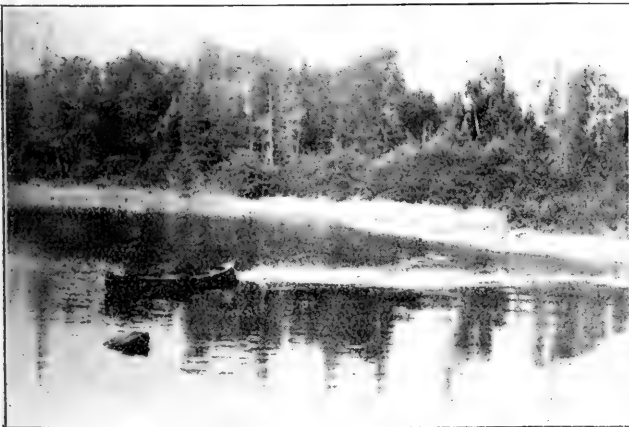

TOOKY SWUNG IN BEHIND AS OUR OUTFIT BACKED INTO THE EDDIES.

Upwards from High Falls, are a series of rapids mostly small, which

may be easily waded with the exercise of a little care. The numerous rapids and falls, make the first day one of arduous toil, but as the afternoon draws in, the smoother stretches of river are reached and we leave behind the first shelter hut which marks the boundary of our Provincial Preserve, Algonquin Park. We are now able to enjoy some solid paddling till Twin Falls is reached, where we will make camp.



THE WATER HISSED AND LEAPED.

The worn rocks on the right bank give indication of the trail, but a few steps suffice to show that we are the first over this season. It is difficult work to push through the wild growth of fern and raspberry which completely obliterates the trail and hides its many boulders and fallen trees. This extends several hundred yards, but through the bushes open water is discernible, making it useless to follow further, what appears to be a disused lumber trail. As we headed back down the trail Tooky broke suddenly into a run and before I reached the water he was madly tearing off his clothes. The canoe was missing, and as I looked, there below the rapids, she was heading out into the stream. Such a predicament! I dashed down the rocky embankment to head her off—and Tooky with a clean dive from shore made half the distance and swung in behind with a strong stroke just as our outfit backed into the eddies. 'Twas just in time—and when the excitement was over we had time to reflect

upon our carelessness and laugh at the humor of the situation.

Further investigation of the opposite bank, revealed the true trail and a very suitable spot for camp. We were tired, dog tired, but a bath works wonders, and after a hearty meal, we were glad to draw up the blankets with the fitful glare of our night fire against the canvas. Away from civilization and the work of man we had opportunity to meditate upon our own insignificance and the greatness and grandeur of the Almighty's handiwork. At our very door the waters hissed and leaped, but gradually the boom of the falls and roar of rapids blended in a grand chorale and our tired frames relaxed in well-earned sleep.

NOTE.—The above covers a day and a half's slow travelling, part being Sunday morning, which can readily be covered in a day.

(To be Continued.)

The Moose.

BY A. R. DOUGLAS.

Amid the forest's sombre depths
The lordly moose holds sway
Proud-antlered monarch, fleet of foot,
The hunter's kingly prey.

Far up the mountain-side he strays
Or seeks the valleys low
To browse in sweet contentment
Where tender willows grow.

He bids defiance to his foes
His challenge echoes clear,
E'en slinks from sight the hungry wolf
Nor dares to venture near.

Long may he roam the northern wilds
Where nature's silence reigns
And vanquish all in battle-royal
While he as King remains.

Preserving the Nation's Fish.

BY CYRUS MACMILLAN.

THE fishing industry of Canada has for many years been an important factor in the nation's riches. Shell fishing for profit has long been followed with remarkable success. The streams and lakes of the country have never failed to contribute generously to commerce and to sport. On the seaboard of the Atlantic and Pacific the harvests of sea and river are a fabulous source of revenue to almost countless toilers, who brave storms and dangers in their efforts to secure the deep sea's toll. Beneath Canadian waters a mine of wealth lies hidden,—a mine that

knows no monopoly and is not controlled by trusts. It yields liberal rewards to honest and persistent labour. Canada provides more than her share in various kinds of fish, for the waiting breakfast and dinner tables of the world. Day after day and night after night her bays and streams and shell fish beds are energetically farmed by the farmers of the deep, until today her wealth of sea has reached enormous proportions. But these rich harvests, it is feared, cannot continue to be reaped in unfailling abundance. Even Nature has her losses; and these losses, combined with constant fishing, will in the end exhaust Canada's waters if art is not called to Nature's aid to replenish the sea with seed. This inevitable result the Canadian Department of Marine and Fisheries has long ago realized; and already, scattered along our streams are numerous hatcheries where billions of

artificially hatched fish are yearly added to Nature's own production.

It is only in comparatively recent years that extensive measures have been taken to increase the value of eastern fisheries by artificial means. In the Atlantic Provinces several hatcheries have already been established, and from these, millions of young salmon are yearly sent into the sea to add to its natural wealth. These hatcheries have been operated with great success and their value is almost inestimable.

The salmon hatchery in Prince Edward

Island may be taken as a typical example of the methods employed on the Atlantic coast to preserve the Nation's fish. The unassuming but valuable little building has been placed on the banks of a quiet stream—Morrison's Brook—in a beautiful sylvan valley. Half a mile from the hatchery the stream flows into Hillsboro Bay, just op-



JOSEPH HAYLEY, THE VETERAN FISH CULTURIST OF PRINCE EDWARD ISLAND.

posite Charlottetown, a mile distant. It is thus within easy access of steamboats and trains, and for transportation purposes is ideally situated.

The work of the fish culturists, while it is full of interest, requires constant care. It extends over a period of seven months. From a salmon spawning stream or lake, perhaps several hundred miles away, and usually in a sister province, the salmon eggs are brought to the hatchery, generally during the second week of November, to be hatched into fish. When the parent salmon in some

far away stream are returning in the autumn to the spawning grounds to breed they are netted by hatchery operators, and in hatchery parlance, "stripped" of their eggs.

The operator takes the live female salmon gently from the net; holds her in the region of the anal fin, with the head under his arm pit; then with thumb and fore finger he presses the abdomen until the eggs run freely into the waiting pan. A male salmon is then treated in the same way; the milt flows into the spawning pan amongst the eggs, and by being stirred lightly with a feather fertilization is secured. The ripe fish are spawned painlessly, with the utmost readiness and ease, and are returned to the water, with rare exceptions alive and unharmed. The fertilized eggs are then transported to the hatchery.

In the hatchery the process of incubation is carefully carried out. The eggs are deposited in black Japanese tin trays about five thousand in each tray. Last season in the Prince Edward Island hatchery three hundred

trays were cared for, or a total of a million and a half eggs. As the eggs are now alive they require abundant oxygen, and a continuous stream of pure water is kept pouring over them day and night. The temperature is not allowed to vary. The trays are perforated with small holes covered with a gauze netting to prevent the eggs floating out. Here there are no hungry birds or fish waiting to devour the eggs as on the natural spawning beds. In the hatchery the only enemy of the little pea shaded jelly-like objects is fungus which rapidly gathers on them and proves destructive, if daily watchfulness and care by

the operator does not prevent its growth.

It is little wonder that the salmon is a fighting fish. Circumstances and heredity combine to make him a self dependent warrior. He goes through life a splendid example of Nature's provision for her children; a wanderer in the deep, he makes his own way alone in the world. In the hatchery the little eggs slowly develop. By the first of February the eyes of the young fish are plainly visible through the jelly-like substance. One by one the organs appear and develop; underneath, the mouth soon shows V shaped; by late April a little tail shoots out from the ovum, and the little fish, still transparent, at last emerges from the egg, less than half an inch long. As a rule it has as yet little resemblance to a fish, but to the naked eye it appears more like a small worm or a wriggling insect. If art protects the little fellow externally, Nature provides bountifully for his existence. Underneath his little body is attached a finger shaped food bag or yoke sac



A. E. MORRISON'S STREAM AND SUMMER BUNGALOW
—LOCATION OF PRINCE EDWARD ISLAND
HATCHERY.

nearly two inches long which contains his store of nourishment for four or five weeks. For that period he is self-sustaining; he thrives on his natural food, and rapidly grows larger. When he emerges from the egg he is at once transferred from the hatchery to a larger tank with gauze covered holes through which water continually streams over him as in the tray; and carrying his food bag, the little traveller sets out on his life journey.

For some days he lies with his brothers in the tank, living on the yoke from his gradually diminishing food bag. His struggle for existence has not yet really



MORRISON'S BUNGALOW AT THE MOUTH OF THE HATCHING STREAM.

begun. As the food supply disappears the little fish begins to change his shape; the mouth, which at first was not used at all, becomes actively movable, and numerous minute teeth protrude from the surface of the jaws. Finally, by the first week in June his food supply is exhausted and the food bag entirely disappears. He is now a well developed fry.

The feeding of fry is not easy, the quality and kind of food requires careful regulation or the result may be fatal. At times they are kept for some days but as a rule a large proportion die if retained long from their natural state. The little voyager must if possible be "planted" as soon as his food supply is gone, or even before it disappears; otherwise he will probably die of hunger.

When the yoke sac disappears, the fry are placed in cylindrical cans, and may be taken several miles by train or boat and deposited in the sea without injury. The water in the hatchery tank is kept at a colder temperature than sea water; if the fry are to be taken a long distance, ice is used to keep the water in the cans cool. The first contact of the little fish with the salt water has thus no injurious effects. Usually when "planting" the fry,

the hatchery operator selects in shore shallows or streams not frequented by large fish, or rocky ridges and banks not far from shore. Here he distributes them in small quantities where predaceous fish are least likely to seek them.

But wherever he is placed, the little wanderer soon learns to take care of himself. He has inherited by the inflexible law of heredity the instinct of his parents. He has been noticed at the time of "planting" to act at once with great alertness and intelligence. He begins now his life long battle. Self preservation is with him the first law of life. Instinct teaches him to be suspicious—to avoid all living things larger than himself. When he gets his first plunge into the sea he immediately darts for the nearest shelter. He soon learns to know his enemies and to shun them; to dart from his hiding place for his food; to hug the pools by day and migrate by night; to swim deep out of the reach of diving birds; to float with head up stream that his breathing may be easier when the water enters at his mouth and passes out at his gills. From the planting grounds he begins his long voyage to the sea, growing rapidly large and plump as he drops down stream. Little can be told



THE PRINCE EDWARD ISLAND HATCHERY FROM WHICH A MILLION YOUNG SALMON ARE YEARLY SENT TO THE SEA.

by the hatchery operators of the sea life of the fish. But by marking liberated fry with identification signs, they conclude that the average continuous sea life of salmon is four years. If they escape the nets or hooks of fishermen and survive the attacks of ocean enemies, at the end of that time an impelling law of Nature drives them in from the sea, like the exile returning to the fatherland up the stream in which their wanderings began and back to the original planting grounds to breed.

It is estimated that over ninety per cent of the eggs taken from the parent salmon by the fish culturists can be developed in the hatchery into fry. There can be no doubt that on the natural breeding grounds a much smaller percentage is developed. For here the loss is great; a large number of the deposited eggs are washed away unfertilized or are gobbled up by hungry enemies—suckers, trout, or birds which always hover in hordes about the spawning beds. The chances of life of the artificially hatched fry when deposited in the streams are no less than those of the naturally hatched fish. Both kinds are equally

helpless, dependent solely on their own resources. Humphrey Davy estimated that not six per cent of the eggs left by the parents on the natural breeding grounds are developed, and Stoddart believes that only four or five fish fit for the table come from thirty thousand ova deposited on the spawning beds. Last season from the Prince Edward Island hatchery alone, a million young salmon were sent out to various streams. The distribution, year after year, of this enormous quantity of young fish from only one hatchery must benefit our waters to an incalculable extent. But fish culture is not a substitute for natural propagation; it is a supplementary aid and support. If the natural mode of production be still fostered and guarded by strictly enforced fishery laws, and if the hatcheries continue to add to Nature's contribution, Canadian waters will yield in future even more abundant supplies of fish; the sporting and commercial resources of the Dominion will be amplified, and the harvests reaped yearly by the fishermen of the country will be largely increased. Already the possibilities of the fishery industry in Canada are enormous.

A Fishing Trip up The River Mersey, N. S.

BY H. H. BURNABY

Early one morning, before the sun had risen, my friend Joker and I with a teamster left Milton, N. S. on a fishing trip up the Mersey River.

Our load consisted of a canoe, two good fishing rods, lots of tackle, tent, candles, cooking utensils, coverings and many other useful articles. Sixteen miles of our route went North over the Annapolis Road. We seemed to cover that distance very quickly, although the road was rough and rocky. We amused ourselves by throwing stones at rabbits, taking turns at teaming and many other little ways. The next seven miles we went West over the most rocky, bridgeless, muddy and hilly road one could imagine. After we reached the In-

dian Gardens, those beautiful fishing grounds, we had a very nice dinner, and felt that the rough ride had done us more good than harm. The rest of the day we spent catching trout and chatting with some Americans and a friendly crowd from Greenfield.

The next morning, before the sun was up, we bid adieu to our friends and started over the lakes on our way to Sand Lake, which is about ten miles up the Shelburne River, a small branch of the Mersey. The first night out we camped about four miles north of the Screecher, and had it not been for a heavy thunder storm, we would have gone several miles farther. We had a restful night except for a few ugly growls from a bear not fa-

off. I was a little scared of a bear, but it would take four or five bears to scare Joker, who, I believe was never scared in his life. The next few days we enjoyed very much, catching trout weighing anywhere from one-half to three pounds. Once in a while we would get an extra large one on, and after playing him a few minutes we would be out a fly and casting line and sometimes even a piece off the end of our rods. The fourth day out we met with a bad storm, and we had a very close call that day. With the wind blowing us about twelve miles an hour, we ran upon a rock which punched a hole in the canoe about six inches square. As quick as lightning, Joker off with his coat and plugged the hole up. We soon reached land and in a few minutes the resin was boiling and then the canoe was soon repaired.

We loaded up again and put out into the lake. That night we reached the mouth of the Shelburne River and pitched our tent. When the nights were coming on Joker would kindly hand me an ax that would hardly cut our butter and tell me to cut some wood for we were in for a cold night. Some nights I wished I had cut more wood instead of nearly freezing or perhaps get more while half asleep and in my stocking feet.

After another day's hard paddling up swift streams we reached Sand Lake; one of the most beautiful lakes in Nova Scotia. In less than two days we caught about a barrel of trout; sometimes we would even catch them at ten o'clock at night.

Early the following morning we packed our camping goods and left on our homeward journey, camping at the mouth of the Shelburne River that night. Forgetting about the many wild animals that were hunting for food around the woods we carelessly left our fish on the ground in front of the tent. We both went to sleep thinking we would be just as well off in the morning. As luck would have it Joker opened his eyes first, and looking out he saw a large skunk eating away at the fish. He woke me up and said:—"Lie still." We were just like prisoners of war, dare not move for fear we would be fired on. The only thing for us to do, and as we did do, was

to lie still and wait till the skunk went away.

Had I opened my eyes first that morning, it would not have been well for us, because I would have just let one of my boots fly at it, and then we would have been in trouble. Feeling quite sore over the loss of so many trout, we broke camp and paddled down over the Third Lake, or Rosignol, to the "Hopper," a swift running stream joining Second and Third lakes. Here we stayed two days, catching more trout and watching logs go through the "Hopper." As we were living on fish almost entirely, we thought a change would be good. We had not long to hunt before we saw a porcupine. After killing and dressing him, we put him on the fire to roast and in a little while enjoyed a very nice meal.

Before the wind began to blow next morning we packed our goods once more and made our way down over Second and First lakes, passing the "Sows," some huge rocks under the "Umbrella," a tree shaped like an umbrella, and through the "Narrows," a deep and narrow channel. We soon reached the Indian Gardens, where our good teamster was waiting for us. Fortunately, he had brought some of Joker's good wife's cakes and bread. Having satisfied our hunger once more, we began to load up for home, and to my grief I found that I had lost my boots, probably left them at the "Hopper" and did not miss them on the way down because we were in our stocking feet while in the canoe. We had travelled about two miles up the Garden Road, when we saw a little calf moose and tried to catch it. I chased it till my feet were so sore I could go no farther, but Joker was just about to catch it when the old moose came after us. By dodging behind trees and rocks we got away safely except for a few bad digs from the old moose. Joker had his two legs cut badly, and I had my left knee put out of business. We soon bandaged ourselves up with pieces of shirts and bags, and made for home as quickly as the good horse could carry us.

We arrived home about eleven o'clock that night feeling quite sore, but were just as good as ever in a few days.

Thus closes the story of a fishing trip up the River Mersey with Joker.



LEAPING SALMON AND DYING DOG SALMON FLAPPING OVER THE RIFFLES.

The Unsolved Mystery of the Salmon.

BY BONNYCASTLE DALE.

EVERMAN, and Jordan after a life long study, Babcock after years of practical work in general fishery matters as well as in hatcheries, Cobb in his reports of the Alaska fisheries, the magnificent work of the special Commissions appointed by the Commissioner of Fisheries of the United States, my own two years work—all have failed to solve the mystery of the disappearance of the salmon from our shores and their reappearance several years later.

Our own country has done little to investigate this mystery. I speak of the Dominion when I state this. British Columbia, under the skillful guidance of John Pease Babcock, is doing all the needed guardian and hatchery work and when we have more leisure, when this the largest Province of all, with its my-

riad rivers, its thousand streams, its countless Islands, sounds and fiords, is opened up more thoroughly for man's settlement, then, and only then, will we be able to take our place in the ranks of the investigating Commissioners of the world.

Only one little fact have we gleaned. The salmon hatched out in our wonderfully scattered watersheds, do not disappear for four years as has been so often stated, for I have been able to trace them for at least one year, if not a little more, possibly one year and a half after they leave the parent stream, from that until the full grown four year old salmon returns to spawn and die on our shores as its ancestors have for countless ages, the mystery of its feeding grounds remain unsolved.

Come with Fritz and I and see the salmon as we do daily.

Let me first of all attempt to describe this wildly magnificent Vancouver Island and remember that although it is our largest western island it is only one among many in this mis-named Pacific Ocean, one and the greatest, along our thousand mile sea line. Picture to yourself a red-topped range of hills and mountains that run along past your limited vision for three hundred and fifty miles, a rolling sea of metal-bearing trap rock full eighty miles wide, clothe these almost to the summits with gigantic red and white firs and tall, noble cedars. Fill in all the valleys and bench lands with alder and scrub oak, bull pine and sallow, salmon berry and wild rose bushes, drape all the half exposed ridges and summits with waving fern and clutching moss and lichen, people these with elk and black-tail deer, black bear and cowardly panther. Cut up every mile of this shore line into fantastic harbors, spit sheltered or rock guarded, some many miles long, others wee bit shelters from the wind and the wave. In turn fill all these with every manner of invertebrate, with all the eatable shell fish, with all the good food fishes, add the sharks and the devil-fish, the seal and the sea lion. Litterally spatter the water with black dots, these are the innumerable flocks of sea-fowl, the ducks of all breeds, the brant, the geese, the swans, all the plover and the snipe. En-

liven the little clearings where man has wrested a few acres from the giant vegetables, with quail and pheasant, ruffed and willow grouse—and into this scene of primeval beauty pour a shining, crowding, splashing, leaping host of salmon that no man may number—then you may have a very small conception of the actual wonders of the mighty island!

Here is a typical island river, the Sooke, a brawling rushing torrent in the rainy season, a thing of clean, blue, pebbly beds and deep, transparent pools and dry reaches in the summer season. Up this now halt dry stream during these early fall days the dog salmon, the coho salmon and the Steelhead trout may be seen struggling. We only get these two salmon out of the five varieties of the Pacific salmon or Russian salmon as it is often called. Remember that this fish differs from our true Atlantic salmon in the manner of spawning. The gamey, excellent eating Atlantic salmon spawns in the fresh

waters, rivers and returns to the sea. The coarser cousin, the Pacific salmon, spawns in the fresh water rivers and almost immediately dies and rots upon the shore, as it is emaciated, frayed, starved, torn and half dead when it is spawning. We divide this salmon into five varieties: the Quinnet, or as it is locally called the spring, the blueback,—this is the local sockeye that you eat as canned salmon all over Canada—unless they put up an inferior fish; third the silver, called

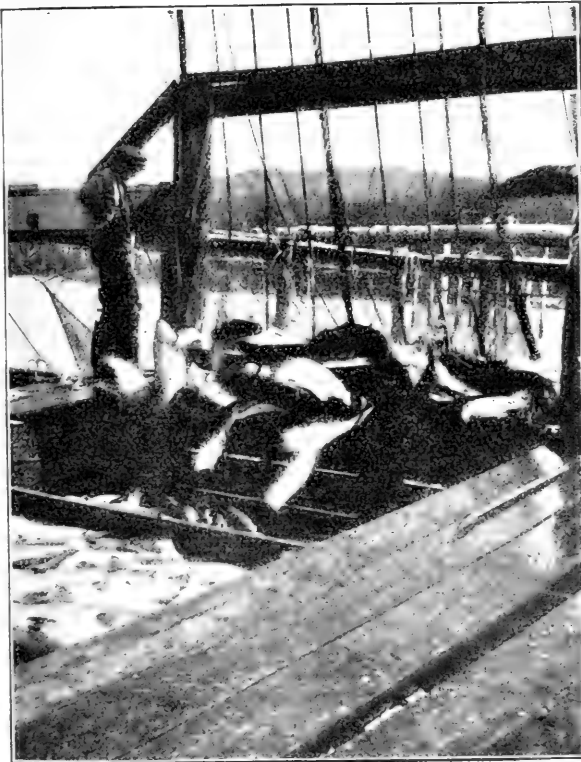

SCOWLOADS OF SHINING SALMON FALLING FROM THE BAILER NET INTO THE SEA.

the coho out here; fourth the humpback, a soft, pink-fleshed fish, not the deep salmon red of the first three good food salmon; and fifth and poorest the dog salmon, a soft pale-fleshed fish. Add to these the big, hard fighting steelhead trout and you have the six fish that yearly crowd up the British Columbia and the United States streams to spawn.

It is in the early fall that the first stragglers, the couriers of the mighty host, arrive. A few of these leap and play about the mouth of the rivers. All during June, July and August huge schools of salmon, mighty, shining living rivers of

past us and to think that they are literally starving, living on the tissues they have builded up. There is a full thousand miles ahead for some of the fish we see passing up the Straits that divide this island from the mountainous U. S. shore, and as these fish swim with each tide, falling back with the next, it takes months to make the full trip. During all this time no food of any kind is eaten by the millions of mouths. Daily, after the egg sacs and milt bags have attained full growth, the fish lose in weight, until later, after they have dragged their bodies over rapids and riffles, up shallow



SALMON CROWDING UP A SHALLOW RIVER.

fish amid the currents of the Straits of Juan de Fuca have passed along the shores of this island on their way to the spawning streams of the mainland. These salmon are spring sockeye and some coho, the families that go far up the great rivers to spawn, hundreds of miles from the ocean mouth. Poor fish! for weeks the egg sacs and the milt bags have been growing larger until now they fill nearly all the body cavity. No room there for a stomach and food, so the stomach shrinks and the fish stops feeding. It is pitiful to look at the thousands of great silvery fish that daily crowd

streams, leaping many a steep fall in the way, they are literally worn to the bone. Many a noble salmon we have seen so frayed and torn by rock and branch and current that its tail becomes extended fleshless from its body, its fins were mere fringes, its body a mass of fungus covered wounds, its once shapely jaw hooked so that it could not nearly close its mouth—and these were not all females, even the males went agape. Onward, ever onward, upwards to the shallows, where both male and female beat and clean out a small depression and the male constantly swimming about the spawning female

impregnates with his milt the several thousand eggs, averaging some six thousand. Many of the fish are so spent that they die before the full course of the spawning is done. Poor, poor fish, what a tragic race it ran to even arrive here at all! As far north as we can trace the starting of the "run," in Behring Sea, the squat natives were active with net and spear and weir. The rivers that debouch into the sea were lined with salmon traps, great long fences of power driven firs, wire netting and cotton net hung, traps that take from a thousand to fifty

into the now diminishing host. No sooner had the survivors of this starving homing army passed the drift nets of the river's mouths and started to ascend the parent streams, or as near to the parent streams as instinct would lead them, than the natives, the Indians to whom by all right the fish belong (and a dying race also) as they form the winter's food of these Pacific tribes, fell upon them with spear and net and weir, dragging the dead and dying fish ashore and drying and smoking them for food, (bad food) cause of the heavy death rate in the tribes.



INDIANS NETTING THE MOUTH OF THE SOOKE RIVER.

thousand fish at one catch. All the sounds and bays and straits held purse and drag nets that took millions from the shining throng. As this gleaming river of fish pressed southward and nearer the rivers a fleet of boats, armed with long drift nets, manned by Japanese, active men of Nippon that have displaced our white fishermen and take nearly all the value of our fisheries back to their island kingdom. These men made sad inroads

Even after this tremendous assault there were sufficient salmon of some of the varieties left to fill the spawning pools in some of the streams. In some rivers the most valuable salmon, the sockeye, had been caught out so thoroughly that none reached the spawning grounds.

We have established hatcheries at some of the headwaters of these rivers, and when enough of the fish are allowed to ascend the stream the eggs are taken

from the female and successfully hatched without the enormous waste that Nature has allowed—if the balance has not been disturbed by man this waste would not have been apparent.

November and December see the shores of the rivers and lakes, the streams and bays lined by the dead and dying salmon. This occurs over thousands of miles of sea and river front. I think one of the most pitiful sights in Nature is to see a male salmon, one that has passed through the spawning grounds with his mate following that mate as it slowly flaps its way along. Lightened of the great mass of eggs, its poor body weakened by its two or three months fast and torn and wounded by its long journey, it has lost its power of balance and continually turns over. The male, while sadly weakened and actually starving, has been able oftentimes to

keep and retain more power and life. Curious as to the actions of his mate he follows, swimming slowly about her as she struggles in the shallows, edging up to her side as she remains motionless, awkwardly plunging off, for he has lost his primal speed and grace, as she splashes and struggles on her side. At last her journey is ended, a few feeble flaps of the once powerful tail, an intermittent waving of the fins, a gaping of the gills—then death ensues—yet the male fish lingers, swimming about and wondering why his once active mate is so long still in one place. For hours he swims about her, wandering off at times, returning ever to his strange vigil.

Finally the current dislodges her and she sinks, submerged on her side, and down the brawling stream the dead fish, and her faithful, dying mate, swiftly disappear.

A New Brunswick Lost Lake Found.

BY ARTHUR L. SLIPP, LL. B.

ON August 10th, 1907, with a single companion I was on a fishing trip on the headwaters of the Keswick River, New Brunswick. We met accidentally at one of the lakes two gentlemen from Woodstock. Louis Brewer, of Stone Ridge, the well-known guide was with them. We remained together a couple of days, and removing to another lake met a Fredericton fishing party headed by a man from the old country and Col. Loggie, of the Crown Land Department. Chas. McGuiggan of Millville was with the Fredericton outfit and at dinner he was telling about a small lake that he camped near twenty-five years ago. He told of the seamless bags full of trout the men used to drag into camp Sundays, and how he and others had hunted many times since for the lake, but never could find a trace of it. Now I had heard about this lake and its bags full of trout from a man at the present time a resident in Woodstock, and whose veracity has never been questioned—in fact he is now a deacon in one of our churches. Brewer had heard about this magic pond. He had hunted for it several times too. Natur-

ally enough we listened and got what information we could.

After dinner we got our crowd together, that is the Woodstockers and Brewer, and had a council of war. Brewer and I wanted to have a try at lost lake hunting. The rest were not at all anxious to plunge into the unknown wilderness. One was pressed for time.

So it fell out that Brewer and I shook hands with all the rest on the banks of the lake and they started for Millville with Col. Loggie's party.

After travelling for about a mile, most of it heavy up-grade, we called a halt to take our wind and take stock of our supplies and see how much information we had to work on.

Our provisions would last four or five days if we caught plenty of fish to go with them.

We knew that the lake was to the right of the Risteen Portage when facing Nashwaak, and that it was on a Gibson Timber Block. It was near an old camp, that was all—little enough.

So we started and toiled on hour after hour over what seemed a never ending

hardwood ridge, stopping occasionally to climb a tall tree to have a look at the country. We were on very high land. Caribou, moose, bears, deer and small game were abundant.

About four p.m. we began to descend into a low winding valley. The character of the timber changed. It was now chiefly spruce. We made up our minds it was what the lumbermen call the Yerxa Block that we were then passing through. Presently we came to a running stream. It must have emptied into the main Keswick.

At five o'clock we were passing over a country covered with stunted spruce and fir trees, and thickly strewn with drift rocks, and not unlike the style of country met with in the Great North.

Having travelled almost continuously for five hours and a half, we at last came to that part of this region where the lake was supposed to be located.

Brewer's idea was to get somewhere near the lake and then follow the beaten animal paths to the lake. This was a good idea, but the paths ran in all directions, and did not go to the lake, as the whole surrounding country was low and well watered. So we tried a different plan. Compass in hand we travelled about one mile east, then turned at right angles running a mile north. We found a little brook, and thinking it might flow into or out of the lake, followed it. But it lost itself in a shaly tundra bog where we nearly got mired.

Now we traveled west nearly a mile then south another mile. Not finding anything in the last mile we walked back to a small brook we had crossed when coming west and followed it up stream until we found it tumbling down stream over great boulders. I said to Brewer that there couldn't be any lake on the top of this hill. He agreed but thought the water in the brook was rather soft to the hand and must come from a lake or a pond.

We were in a pretty pickle. It was within a half hour of dark. We hadn't found the lake, we had no dry wood for a camp fire, no blankets or overcoats, we were wet and hungry and a downpour of rain was about to commence. Most of my gentle readers will remember that it

rained almost continuously during the month of August '07. However we concluded to follow the brook up the mountain side and what do you suppose we found? The lost lake. It was a little beauty too. While Brewer peeled bark and cut poles for the camp I cut an alder and rigged a line on it. The first cast—no fish. The second—the water boiled with them and soon we had enough for supper—all even size like herring. We made a bark camp and got a supply of wood, the last by torch light, and having raised our bough bed off the wet ground slept soundly till morning although the rain fell constantly in torrents.

Next morning after catching what trout we wanted in five minutes, we blazed a trail to within 100 yards of the Risteen Portage. Then we walked out to the above named road and inscribed our private marks on a large spruce tree. Then we returned to the lake and took life easy for a time. When we left the lake we struck off east instead of retracing our steps westward so I never saw the marked spruce tree again, but think we could find it again as we made a map of all the country traversed on this trip.

We did not catch any fish out of this lake to take home as we were sure of them in another lake we intended to visit before going home which was ten miles nearer the railroad (i. e. Sills Lake.)

It would not be relevant to tell under this heading of how we found another lake so roiled by four moose that were paddling around in it that the fish in it couldn't see and we couldn't catch any there; or how I lost the bottle of fly dope and consequently the flies almost devoured us; nor of the giant moose horn half eaten up by porcupines that we found and brought home as a souvenir. We visited lake after lake, always journeying southeast and camping wherever night overtook us.

At last after a zig-zag course of over fifty miles we came to the railroad at a point fifteen miles south of that at which we entered the forest ten days before. We named the lake "Lake Louis". Some of the New Brunswick Land Co's surveyors, a lumberman or two, and some trappers are the only ones that have been there in twenty years.

A Moose Hunt in New Brunswick.

BY W. W. L.

LEAVING St. John, N. B., at seven forty-five on the morning of September, the eighteenth, on the Shore Line Railway, we arrived at Lepreaux station some time during the morning. (Anyone who has ever travelled on the Shore Line knows that that time is quite accurate enough for that railway. It must be seen to be appreciated.) There we found a buckboard and our guide, Arthur Shaw, waiting for us.

We loaded our provisions on the buckboard and drove six miles into the woods over an old lumber road. It was almost easier to walk than to try to stick on the team, but our driver was a good one and our provisions were tied on firmly. But the stones and bumps were huge. At one jolt I left the front seat so far that when I came down I lit in the back seat and I can assure you I did not stay lit long, but lit out for the camp on my feet.

When we arrived at the camp—which, by the way is perfection itself in the way of luxurious sleeping and cooking appointments—hungry as we were, we could not but pause on the wide verandah to admire the beautiful surroundings. In front of the camp stretched the broad expanse of Seven-Mile Lake, the shores thickly wooded with magnificent evergreens and hardwood, the foliage just changing to yellows and reds. The woods were close to the camp on every side except that of the lake.

The next morning we were up before daylight, and after a hearty breakfast—set off through the forest—Arthur carrying a lantern and we keeping as close to it as possible. I can never describe the

beauty of the dark, silent, frosty woods—one has to be there to feel the whole fascination of it. Before dawn we were ensconced on some hill top, and to see the stars fade, and the dawn brighten in the eastern sky, while every twig and blade of grass began to sparkle and glisten as if incrustated with diamonds. Oh! at such moments it certainly was very good to be alive, “and to be young was Heaven.” At dawn, Arthur began calling for moose, with a horn he had made out of a piece of white birch bark. But the wind came up with the sun, so calling was over for that morning. He called again at sunset from another location, and again at sunrise on Monday, but without tempting a moose forth from his forest home, although he got several “long distance” answers.

Tuesday morning arose at three-thirty, and after a tramp of about six miles we settled ourselves on a hill top near the Ragged Falls, the most perfect spot it has ever



A BIT OF THE RIVER.

been my good fortune to behold. We could see for miles around us—small wooded hills and valleys and lakes and the Lepreaux River winding like a silver ribbon through it all. When we first reached this place it was only half light, and as the dawn came and this sight unfolded before us, like some wonderful panorama, all touched with a silver brush as the frost glittered on every twig—it was a sight one sees but *once* in a lifetime and *never* forgets. As daylight came Arthur began calling moose, and called at intervals until about seven o'clock. By this time there was quite a breeze stirring, so he decided it would be of no use to call longer. So we shook out our cramped

muscles and even ventured to kill a stray mosquito or so, and decided we would stay right where we were for an hour or so longer and *absorb* some more of the beauty. Suddenly Arthur made a sign for silence again, and we simply flattened out.

(His quick ear had heard a moose about a mile away in the woods.) He reached for his horn and sent a long call far off into the forest. For an instant afterwards there was silence; and then faint but unmistakable, we heard an answering "waugh, waugh!" After a moment Arthur called again, and then—Oh! the joy of that moment! The moose answered loudly, and we could hear him coming up a wooded gully towards us. We silently got our rifles ready, putting our sights at one hundred yards. We could now hear him cracking brushwood and twigs as he came along carelessly through the woods; and his "waugh waugh s" were now just

a grumbling murmur. Now he could not be more than two hundred yards from us, and we scarcely breathed but watched with every muscle tense, for him to emerge from the trees and undergrowth. But now there was silence and Arthur

sent a low coaxing call, but all in vain did we listen for an answer. For many minutes there was silence, broken only by Arthur's occasional calls—and then he told us in heart-broken whispers—"He's got wind of us and gone back into the woods." Just

fancy, that huge beast had got suspicious and sneaked silently back to the forest without so much as stepping on a dry leaf or twig. After ten minutes Arthur picked up his horn again, and gave a long peculiar call. For a moment, silence—and then, about a mile away, where we first had heard him, Mr. Moose answered again, but very faint and hesitatingly. Arthur called several times, and finally he decided to make another tour of investigation, and we could hear his answers coming gradually nearer. But this time he came very suspiciously, and we heard no breaking branches or snapping twigs.



OUR GUIDE, ARTHUR, CALLING A MOOSE.

Right here I want to say that until you have heard a moose coming, answering the guide's calls—you have missed the most thrilling moments in your life. Presently we heard him give a long grunt, and start out of the trees on the op-



THE CAMP ON SEVEN MILE LAKE.

posite side of the gully from us, and still quite a distance off. (Arthur just breathed "three" and we changed our rifle sights from one to three hundred yards.) Just then we caught our first sight of him—and I can tell you that was a moment to be remembered forever, as the bushes parted and the majestic animal appeared and started walking up the bare rocky hillside. About six strides he took, then turned partly towards us to listen. At that instant our two rifles rang out simultaneously, and then again—and he dropped, half staggered to his feet again, and slid down the steep rock into a pool in the brook, dead. Three hundred yards may have been quite a

distance to shoot but it certainly did not take as long to get to our game, as we rushed through that gully we touched only the high places. After the meat was dressed, the portage out to an old lumber road was a hard piece of work, for the meat must all be taken out of the woods. But the next morning we cheerfully walked in the six miles to the station, while the team took the meat and head.

Old moose hunters tell us that it was a most wonderful thing to get that moose back the second time—for a suspicious moose is the canniest thing in the woods and Arthur certainly was a wonder to get him back for us with the breeze blowing in his direction. This winter we will have the antlered head, and look back pleasantly to our first moose hunt.



SEVEN MILE LAKE—VIEW FROM CAMP.

The Old Home.

BY DR. WYCLIFFE MARSHALL.

In my childhood there was an oft chosen by-way,
 Where grass in midsummer was wavy and long
 And where, in its joy, was a very bright river
 That rippled and babbled and murmured its song.

And there on its high grassy bank was the beechwood,
 The far reaching elm cast its shadow around.
 'Twas there too the Canada maple was growing,
 And bright fiery tassels of sumach were found.

While on through the patches of shade and of sunshine,
 In ripple and eddy still dancing away,
A dear old, clear old beautiful river
 Kept murmuring and singing the whole summer day.

And there too, the red-breasted robin was singing,
 The bluebird once swayed on the branches on high
As if undecided which charm to be seeking ;
 The green of the earth or the blue of the sky.

And still from the depths of the shadiest places,
 With ripple and song never ceasing to run,
That dear old, clear old beautiful river
 Whirled merrily into the light of the sun.

And there leaped the trout through the rapids and shallows
 Midstream by the dead whitened bough of a tree
Where oft in his glory the bold old kingfisher
 Swooped down on his prize 'twas intended for me.

While I, youthful angler, expectantly waited
The impulse conveyed by the twing on the line
 That hung in that dear old beautiful river
Whose bright speckled beauties no more may be mine

E'en now the gay butterfly flits o'er the water,
 The wild bee returns to the sweet scented flowers,
The pretty clothed bob-o-link flings o'er the meadows
 His shrill whistled praise of the bright sunny hours.

The stately old Hickory still does invite me
 To come back and lounge in the depths of the glen,
That beautiful, beautiful, beautiful river.
 Is calling me back to my boyhood again.

No more by the bend where the water is deepest
 I pile the few garments a boy needs to wear,
No more may I plunge in the pure gurgling water
 To sport with its ripples, their coolness to share.

For I'm far away from that green grassy meadow
 While time into years passes swiftly along.
But still in the distance that charming old river
 Is calling me back with the voice of its song.

Bass Fishing in Florida.

BY EZRA P. YOUNG.

THE writer has spent several winters, very delightfully too, on the west coast of Florida at the village of Dunedin, a small place not far from St. Petersburg and quite near the well known Florida resort, Belleair. Sailing and fishing on the gulf are the sports most enjoyed by visitors and few seem to know of the possibilities of hooking black bass in the fresh water lakes which are so plentiful in this locality. During my first winter's stay in Dunedin I did some little fresh water fishing in a small lake two miles inland, Lake Jerry. Not having a guide I took a companion along, one who enjoyed a bass "strike" too. The boat used was leaky and rather clumsy and I had no suitable bait, it being next to impossible to obtain live minnows. Having some Phantoms along I tried them and caught a number of bass. We alternately pushed or paddled the boat around the grassy shores of the lake, one propelling while the other trolled for fish, all fish caught were hooked close to shore along the edges of the lily pads or water grasses. They were big mouth bass, the only variety of bass found in southern waters.

Profiting by my first winter's experience I procured a canvas boat up north for the next winter and a supply of Dowgiac minnows for bait. The collapsible boat was shipped early in the fall by freight so that it would be sure to be

ready for me by Christmas, when I expected to be in Dunedin. I think it was in February when it did reach me and after I had given it up as hopelessly lost.

The little boat although very light would easily carry three and it was just what I needed for portaging around from lake to lake. Two of us could shoulder it and carry it a mile without much fatigue, it didn't leak a drop and could be rowed with ease through the shallow water. Some of the lakes are shallow, covering large areas with occasional deep holes, and in these we caught our fish.

One morning in February, a bright Spring morning such as we have up north in June, we pushed our little craft into the waters of McClung's lake, about a mile inland, pushing through the reeds and rice a short distance we floated into the first deep pool. Armed with my light steel rod and Dowgiac minnow I soon landed a three pound bass and before leaving the pool I had four beauties. Leaving this pool after getting about all the fish we thought it would yield on this particular occasion

we again pushed into shallow water. For about a mile we rowed through shallow water covered with a growth of wild rice and swamp grass. Seemingly we were sailing through a great grain field for no water was in sight. Finally, a little ahead I saw some dark water, quite a pond of it. Getting my rod and minnow



MR. E. P. YOUNG WITH HIS FINE FISH.

in shape I had my companion slip up to the deep water very quietly with our little boat. We felt sure that bass were lurking in the depths of this pool. While still floating in shallow water I made a cast ahead among the lily pads that skirted the pool and my bait had hardly touched the water when I felt a big tug, sending an electric thrill through my body. He took nearly all the line off my reel before he stopped at the further side of the pool. I knew he was firmly hooked and it was only a question of tiring him out to land the big fish safely. I saw and felt enough of him to know that he was the biggest bass I ever hooked. My little steel rod bent double as I checked his speed. When I tried to keep him from entangling the line among the lillies he tugged and pulled like a whale. I have never seen a big mouth bass show so much game. Twenty minutes later I drew him up meekly alongside the boat put my fingers through his gills and lifted my ten pound bass into the boat. His length was twenty-four inches and he was certainly a beauty. Several other

'little' fellows weighing only three or four pounds were added to our string in that pool before we went home triumphant with our ten pounder.

Bass and brim are about the only two good varieties of fish found in these lakes. There is little fishing done, however, and the waters abound in these fine fish. I saw one native trying to "bob" bass, he was on board a sort of ark made boxy of pine boards and painted bright red, a danger signal probably for the fish. Armed with a long pine pole, a short line and bob with bait on its end he bobbed along but bobbed in vain and seemed much surprised at our luck when he never had a strike.

On these waters we find the blue heron, our Ontario crane, wading in the lakes and nesting in the low shrubbery growing in the water. They find the winter climate in Florida very much like the summers in Ontario, averaging about seventy. Like these birds and the wild geese I fly to the south in the winter and it might be called a "Wild Goose Chase!"

A Quebec Fishing Lake.

The praises of Brome Lake and its fishing advantages continue to be sung. Last fishing season saw a number of visitors on the Lake, some coming from England, and others from different Provinces and States of the Union, while all appeared to be satisfied with their sport.

Brome Lake is in the Province of Quebec and is about five miles long by three wide. It is a beautiful sheet of water, eight miles from Sutton, and easy of access. It was in this lake that Mr. E. J. Carpenter captured his record black bass as stated in our November number. Our present illustration shows the result of a July day's hook and line fishing by Messrs. Clark, who are proprietors of a butter tub factory at Sutton, and who in addition to a couple of pleasure trips across the lake, caught thirty-six pickerel, weighing ninety-two pounds, the shortest being twenty inches.

The gentlemen holding the upright pole in his hand is Mr. George E. Clark, with his eldest son, George Clark, Jr. to the left, and two young twin sons in the stern. The other gentleman with the cap is Mr. Wm. C. Clark, the senior member of the firm. The Messrs. Clark are well known business men and sports-



men—known from Montreal to the Maine Woods and through the Megantic region as well as in Northern Vermont.

A Day at "the Orifice."

Black Bass Fishing in the Cool Waters of the Georgian Bay.

BY G. J. MITCHELL.

HAPPY indeed is the fisherman who can avail himself of a vacation in bass time, that delightful season of the year when one most strongly desires to get out of doors and away from the city.

'Tis not difficult to analyze the feelings of an ardent angler who finds the summer slipping away with no opportunity offering to cast line on water or feel the exultant thrill of a lusty strike. Such indeed seemed our portion, when, the holiday falling on a Monday, gave us an extended week-end which looked particularly inviting and we made hurried arrangements for an assault on the bass family.

I had been invited by an old pal to join him on a visit to his family at their summer home on one of the many islands of the Georgian Bay, whose adjacent waters promised some famous fishing and my acceptance was but a matter of course. With our tackle and outfit we boarded an early Saturday morning train that, contrary to expectations, landed us at our destination on time. Transferring our belongings to the launch, a short half hour's run up the choppy Narrows and we were landed at "Kilcoo," hungry but happy with that feeling of an enjoyable freedom that follows an enforced six months' grind at the desk.

Luncheon over, we changed to soiled ducks and jerseys which made us, if possible, more comfortable and were soon busy selecting tackle preparatory to a sortie on the "*Micropterus Dolomieu*" or preferably small mouth Bass. With indifferent luck we tried the likely spots and returned at sundown with a fair catch.

Sunday we spent quietly, following a dip in the Bay and breakfast, we convoyed the children in their rambles over the Island and enjoyed, quite as much as the youngsters, the many little happenings incident to such a tramp. After dinner, a most elaborate meal, we struck north-

west and did a four or five mile stroll, returning in time for tea. Winding up the rocks towards the cottage, which nestled cosily amongst the trees, and facing the bay, the view before us was indeed beautiful and amply justified our host in his choice of location. We were driven indoors in the evening by a passing shower accompanied by most vivid lightning flashes, whose reflected glare from the placid waters of the bay provided a most interesting display.

Five-thirty found Haec and myself astir; with a gorgeous sun-rise before us as we paddled across to a small island not far from the river mouth and landed four nice fish before breakfast, including a four pounder that strained the Bristol to the breaking point as he swirled back and forth, breaking water, chugging and gamely fighting until finally exhausted he was lifted into the boat and despatched. Returning for breakfast we found the family busily preparing for a day's fishing at the "Orifice," a bass ground of much repute, some two and a half miles north east. A shortage of bread necessitated a run to the port which we made in record time before a spanking breeze in a St. Lawrence skiff with a leg o' mutton. The two larger boats with the Governor, his daughters and their husbands had gone away sometime before when we followed in the canoe, which loaded as it was with lunch baskets, anchor and sundry tackle afforded scant free-board for the rather choppy roll which we encountered as we rounded the point and faced the Georgian proper.

With some slight shifting of ballast we tackled it and had an exciting paddle of twenty minutes or so, the big white capped combers that rolled up to meet us threatening to capsize us at any moment. With the spray in our faces we stuck to the paddles and watching our opportunity came about and made the channel,

where, once inside, the water was as smooth as the veritable mill pond. We went ashore, emptied the bilge water, rearranged our disordered cargo and again set out. A short sprint brought us up with the rest of the party who signalled to come ashore for luncheon. Appropriating a disused camp for the purpose, a fire was lighted and we shortly sat down to a smacking fine dinner with an excellent pot of coffee that required the combined efforts of the party to rescue when our fire place collapsed under the strong breeze.

The meal over, we launched the boats and paddled across to the "Orifice" at the mouth of the channel, anchors were run out and the assault began. A sweeping swell rolled in from the bay and our small craft were kept in active motion, though the conditions were well nigh perfect for good fishing. We had it, my dear readers! But I am anticipating. The first fish, in true courtier style, went to the ladies, the governor immediately followed with another and for sometime thereafter followed a succession of strikes, struggles and exciting captures. Our canoe well placed just off the rocks seemed out of the run and we pulled up anchor and back paddled a hundred feet or so farther out. In a minute we got a strike and landed a two pounder, in twenty minutes we had a half dozen, two over the three pounds. During the afternoon a number of others were added to the catch, thick sturdy fellows who took bait warily, but once hooked and you had a thrilling few moments as they swirled under and about the canoe, forced you to give line as they made off, and again coming to the surface with a mighty spring, made their best efforts to dislodge the hooks. These were the small mouth black Bass in their native environment and well worthy of any man's seeking.

While we were engaged in this most enjoyable sport one of our party chose to enliven the proceedings and added a dash of color to our outing by accidentally plunging overboard from his rather precarious position on the after gunwale, describing a most graceful arch as he descended into the cool waters of the cut. Reappearing shortly he was soon rescued and taken ashore, a change of clothing supplied by the various members of the

party while his own were drying, soon restored his good humor and he returned to his fishing none the worse for his ducking, to find the fish had remained in his vicinity with commendable loyalty, as he demonstrated by almost immediately landing a fine three pound bass.

Our catch now numbered some twenty five, averaging, possibly, two pounds each and the boats hauled line and prepared for the homeward trip. The sport was of the best and though loath to leave Haec and I each with a fresh bait cast for the last fish. My twelve foot of line had barely reached below water when I felt a tug in response and after a short, crisp tussle lifted the last black beauty into the boat. Stowing the tackle we raised anchor, knelt to our paddles and started on our return to the camp.

The gale of noon-day had subsided when we slowly made our way down the wide reach connecting the bays. With a glorious sunset before us we wound in and out of the rush beds, the soft twittering of the reed birds hushed in unison with the restful silence of the summer evenings in the north country proving grateful indeed to eyes and ears accustomed to busy streets and clanging car-bells and we wished for a longer holiday that we might enjoy its pleasures and delight in the open. 'Twas deep twilight ere we made the wharf and after a wash up sat down to a bounteous supper at which two of us at least fairly outdid ourselves. The catch was entered in the official log and we shortly climbed aloft, being reminded of an early start in the morning. A few minutes spent in packing for the return trip and the lights were out. I said "good night," everybody pulled the blankets closer, turned once or twice, settled comfortably and lo; it was morning—with a cheerful voice calling us to get up. A hasty breakfast, after which good-byes were said to our kind host and family and we stepped aboard the palatial launch of an accommodating neighbor, caught our train without difficulty and shortly stepped down at the "Union," well browned by the sun, with a pleasant memory of our week-end on the Georgian and a substantial box containing the catch of, probably, the finest black Bass it has ever been my pleasure to hook.

A Day in the North Woods.

BY CHARLES CAMERON.

WE had that morning located the ground where deer were actively working, and had taken close observation of their runways. At an early hour in the afternoon we took our positions, and the wind was in our favor. From the place I had selected under a spruce on the brow of the hill I could see two runways that united a short distance below, and led to the head of the lake where deer were accustomed to go down and drink and wallow in the shallow water near the shore. About sixty yards south of me my guide had stationed himself where he could see still another runway, that led down through a ravine and joined those above referred to leading to the water.

I was so situated that I could see a small part of the ravine over which the guide was keeping guard, and I probably spent quite as much time watching in that direction as I did in scanning the two converging trails in front of me. I felt quite sure—without knowing why—that if our anticipations were realized the developments would be along his ravine and not on my side of the hill.

It was tedious waiting, but the monotony was somewhat relieved for a time by the audacity of a red squirrel that evidently had his home in the maple at the foot of which the guide had entrenched himself. From this tree a hollow log extended out almost to the edge of the ravine, and was the avenue through or over which the little quadruped usually travelled to and from his home. Upon his return from a foraging expedition shortly after our arrival, he saw the log was occupied by an intruder, and barked a vigorous protest from the farther end; but by degrees grew bolder and approached nearer and nearer until he was not more than ten feet from the man on the log, and then persistently barked defiance in his very face. It was difficult to know which was disturbed the most. It was plain the hunter did not want to make any movement to frighten the squirrel away, but knew his angry chatter would

indicate to an animal as cunning as a deer that something was alarming the rodent, and that it would be safer to keep in the background. At length the squirrel realizing that he could not dislodge the occupant of his pathway, jumped from the log, made a detour and went up the tree; I then supposed the incident was closed. Unwilling to give up the contest however, he immediately came down the tree and barked more furiously than ever, directly over and within a few feet of his enemy's head. This was too much. The Winchester that was intended for another purpose was used for a club, and the daring creature had such a narrow escape from an untimely end that he scurried up the tree to his home and caused no further trouble.

We had been concealed for hours and it was getting late. We could tarry but little longer and expect to reach our camp that night. The patches of sunlight that had forced themselves through the tree-tops here and there, grew smaller and smaller and then disappeared. The gloom of the forest began to deepen, and we knew that a darkness in which human eyes would be of little service was coming speedily. Still we waited. I had just scrutinized closely the runways on the hillside, and not seeing anything turned to see if conditions were the same in the other direction, and suddenly, just as I turned, two gray shadowy forms came loping down the ravine. A buck and a doe. It was too dusky and the timber was too thick for accurate aim, but the guide took the chances and fired; I hoped for the best but he had missed, and a second time he fired, at longer range of course and with no better results, and they both disappeared around the base of the hill. Turning to me he said "the jig is up, we won't see any more deer around here to-night", and it seemed to me there could be no questioning his conclusion.

To miss twice under any circumstances seemed to him a reflection on his reputation and he was not in a talkative

mood as we prepared to take our way homeward. He at once set a good pace, while I silently followed but was careful not to fall too far in the rear. The trail—if it could be called a trail—seemed to become more and more obstructed by fallen trees and bog holes, and when we found ourselves in a dense cedar swamp, my pathfinder paused to take his bearings, then turned abruptly right about and started in the direction from which he came. Thirty years' experience as a guide had not made him infallible in following a rough and little used pathway through the dense forest in the semi-darkness of the coming night. He had lost the trail and knew that he must find it speedily or we must spend the night in the woods as best we could.

I followed as before, but noticed that he was swearing steadily in an undertone. I have no doubt he had to swear in an emergency of this kind, but I liked him for being so considerate of others that he would not swear out loud. It was evident however that he was quite proficient in this line, as the flow of words continued without interruption until the difficulty was overcome and he was safely on the right trail; but I am inclined to think that the fact of missing the deer both times stimulated him somewhat in expressing his sentiments.

Presently he stopped again to take his bearings—and breath—and I heard him say to himself “now I'm too far the other way”. Again he turned about and retraced his steps, and after going a few hundred feet for the third time halted, and taking a careful survey of the surroundings, said, “now I'm all right”. It was not quite clear to me that it was “all right”, but it proved to be so for in a short time an opening in the forest showed that we were approaching the landing where our boat was concealed. We had a row of three miles before us, and it was too dark even on the water to be agreeable, but we were able to find our landing without much difficulty.

After the routine work had been done that night, the tent flap fastened down with a safety pin, the lights put out, and we had found our respective places under the blankets, I recalled the events of the day. I would not admit that I was disappointed, but I could not help feeling

how much more satisfactory it would have been if that bullet from the Winchester had lodged just back of the shoulder blade of that handsome buck, instead of burying itself in the mud of the ravine. It occurred to me also that my views in this matter might not harmonize with his, and the fact that the bullet went wild that was intended for him was probably not keeping him awake.

Perhaps it was reflections of this kind that kept me awake longer than usual. At all events I was still thinking the matter over, when I felt my partner, who had been asleep, strike vigorously at something and hastily light a match. “What is it now?” I asked. “A spider as big as a mouse was on my face, and he is coming for me again,” he answered, as he held the match to the ground with one hand and struck at the aggressive insect with the other.

It occurred to me that it was a little out of season for spiders, but I had learned not to question his views on wild things whether insects or larger game, and inasmuch as I am so constituted that I have no desire to have spiders the size of a mouse, or even those of a smaller species, explore my face, I asked with some concern as to the result of his second attempt on the life of the midnight prowler.

He assured me that he had exterminated the insect, rolled himself up a little tighter in the blankets, and his deep breathing soon indicated that the interruption had ceased to disturb him.

The hoarse inimitable hoot of the great voiced owls has always interested me, and I have often listened to their answering calls, one near, the other far away, and wondered why they placed themselves so far apart, when exchanging their evening compliments. Possibly they may have learned that it is at long range, and when giving full expression to their deep voiced notes, that their owlish sentiments can be most appropriately expressed. At all events they no doubt have reasons of their own that we need not try to understand; at least that is what I thought, as from our camp I heard the lusty call from the forest on the mainland across the bay, answered at regular intervals by a hoot from our island home, and I listened to this hoarse dialogue until I also fell asleep.

A Nova Scotian Fishing Experience.

BY HAROLD B. WHIDDEN.

FLAT Lake is situated in the depths of the largest area of forest land in Antigonish County, Nova Scotia, and is only a few hundred yards distant from the old stump that marks the boundary line between Antigonish and Guysborough counties. This lake was dynamited four or five years ago by some useless characters, who not being able to catch the trout inhabiting the lake in a sportsmanlike manner, took revenge on the fish by dynamiting their place of abode, and thus killing hundreds of very fine trout. This, however, did not prevent Flat Lake from remaining a home for thousands of trout, owing to the fact that at the time the dynamiting took place hundreds of trout were in the brook which runs from the lake into the South River, and these with others from the river soon returned to their old home.

Two years ago Flat Lake was leased from the owner of the surrounding land by three sportsmen, namely, Dr. Huntley MacDonal, Dr. C. S. Agnew, and Mr. C. M. Henry, who organized, what is called, the "Valley Fishing Club." Since leasing this lake they have imported some very fine trout fry, which they placed in the water, and when these trout are fully matured they will weigh from four to six pounds.

I was invited by a member of this club to accompany them on a fishing excursion to their lake and of course accepted. The pleasure was enhanced by the anticipation of being once more in the woods.

As Mr. Henry was unable to accompany us, much to our regret, there were just three of us to form the party.

We had only been driving about an hour when it commenced to rain, but being filled with determination which none but a lover of sport can possess, we determined to keep on, rain or shine. After driving twenty-three miles we arrived at Polson's brook, (the brook that flows from the lake,) and put our horse in Mr. Wm. Polson's barn, as his home is handier to the lake than any of the other houses in that district. After finishing



THE HUT. (FROM LEFT TO RIGHT) DR. C. S. AGNEW, WM. POLSON (THE GUIDE) AND DR. HUNTLEY MACDONALD.

our various duties about making ourselves known etc., we proceeded on our tramp through the woods, and I must say that we presented a laughable spectacle, each carrying some peculiar article or articles, such as blankets, a frying pan, fishing rods, fishing baskets and last, but no means least, the grub.

After walking along a narrow, rough path in the thick of the woods for about two and a half miles, we came to the club's shanty which was built the previous winter by Mr. Polson. Our first move after arriving at our destination was to eat a good big lunch, and we certainly did eat, as we were more than hungry, we were starving.

We were not in the very best of spirits now as the rain had not yet ceased, but instead was coming down in drops as big as marbles. However, we soon found plenty of work to do, to keep us busy, and to our surprise and regret we discov-

ered that the scow was not in good seaworthy condition, her bottom being one mass of holes and cracks. A little oakum driven into these openings made a great difference, but did not make our craft water tight.

The rain ceased almost as suddenly as it had started, so we soon had our scow launched, and were afloat. Although it seemed hard to believe, we were speedily fishing at the place of our dreams, Flat Lake. The Doctor caught several trout, but the recent rain put us at a great disadvantage, as we were fishing with flies. I had never fished with a fly rod before, and when I think of the awkward manner in which I made my casts on that occasion I have to blush and laugh. I will guarantee that if my line tangled in my friends' lines once that night it tangled fifty times. At last I became so ashamed of myself that I stopped fishing to give the Doctors a chance such as they rightly deserved, and as the scow was leaking badly I spent the time bailing. At times when the craft did not need

the assistance of the "tin can," I would watch my friends admiringly, as they cast their long lines and placed the flies on exactly the spot on which they wished them to alight.

Darkness prevented further fishing that night so we beached our "flat box," and proceeded to prepare a hot supper. Dr. Agnew made a fire under a large stone where the rain neglected to fall. Dr. Huntley made the tea, boiled the eggs and fried the beef steak. To our disappointment Mr. Polson, our guide, would not accept our invitation to eat at our house, but went home saying that he would return in the morning. The hot food certainly did taste good that night, and

we all declared that we had never tasted anything to equal it.

The way we spent the night in that hut will never be forgotten by any of us. We all slept in one large bunk packed like sardines, but that did not aid in keeping us warm, and the rain prevented us from securing some spruce or fir for a tick, and as we had only three blankets between us, each person wrapped in one and we were cold, cold, cold. Dr. Agnew slept on the weather side and he became so uncomfortable that he got up at half past three in the morning and dressed. Dr. Huntley and I arose an hour later, after securing about an hour's sleep.

Talk about rain! We certainly did have it in that locality. It seemed as if the main pipe in the clouds had burst

right over our dwelling. There was nothing for us to do now, but to wait until the rain let up a bit, and during that wait the interior of the hut would have presented a very amusing spectacle to any one who could have seen it. One fellow was sitting on the edge of the bunk with his



AFTER THE SPORT.

legs hanging down, another sitting on an old cracker box, using it as a rocking chair, and the third was walking from one end of the room to the other in such a serious manner that one would think his life depended on the number of times he crossed the floor. One was whistling and keeping time with his feet, another singing, and a third humming, each trying to make a louder noise than his companions, and each using a different tune with not a note of music in them all. As the rain did not abate we decided to pack up for home. Dr. Huntley went over to the lake to get his rod, which he had left there the night before, and soon returned but to our surprise had not only his rod but a

beautiful trout. The Doctor was about as much surprised as we were and said with us, "that we had never heard of catching trout with a fly in the pouring rain." This event gave us new life, and we were soon fishing in the pouring rain with flies.

Our flies were in great demand that rainy morning, and when the sun came out about ten o'clock, we had an hour's fishing which would be hard to beat, as with every cast we would catch one or two beautiful trout.

I had improved greatly in my casting, which was due to the coaching of my kind friends. After catching all the fish we wanted we landed, and were greatly pleased to find Mr. Polson at the hut with a large fire in readiness for us. After eating a hearty, warm meal in the historic dwelling, we proceeded on our journey through the woods, but not without a feeling of sadness at leaving the scene of our very pleasant outing, which was enjoyed immensely by the three of us.

I shall never forget that morning. Every thing seemed to be endowed with new



HOMeward BOUND.

life. The grass was much greener than on the day previous and looked as if it had grown at least an inch. The buds on the trees of the previous day were now leaves and the birds sang as if they were in a new world, where they had to sing their sweetest.

After bidding our friend adieu, we proceeded on our long journey home, where we arrived without meeting with any notable adventure on the way.

A Derelict.

BY THE REV. A. L. FRASER.

In robes of splendour once men saw thee leave
 Some dipping shore, borne on a swelling tide,
 And to the offing thus so proudly ride,
 While fancies for thy future they did weave.
 We find thee now,—not where far billows heave
 Round steaming prows, that sail the boundless main;
 But on this tideless flat, where thou hast lain
 A thing undone,—for which thy friends must grieve !

Likewise, in quiet coves within life's bay
 Are stranded ones, who bring from us a tear,
 As we return to some glad golden day
 When thine clean canvas caught the lifting cheer :
 In vain for them now blows the buoyant breeze
 That bids each flapping sail to try the seas !

Conservation of Non-Nest Building Fishes of the Great Lakes *

BY W. E. MEEHAN

PROFESSOR Baird, the first United States Fish Commissioner, once declared that fishes should be artificially propagated in such vast quantities that it would be unnecessary for either the Nation or any State to enact laws declaring a close season at any time of the year, not even during the spawning period. The utterance at the time was generally regarded as the expression of an enthusiast and as a brilliant dream impossible of fulfillment. Conditions, and the position which fish culture then occupied, seemed to warrant the general incredulity with which the utterance of Professor Baird was received; indeed it is not yet entirely a fact accomplished, though with few exceptions possibly it could be, if the National Government and the States would or could furnish money enough to hatch all the fish required to meet the needs and demands of anglers and the market. Professor Baird's remarks, which may be regarded in a measure as a prophesy, is nearer realization than was thought possible a few years ago. It is generally freely admitted, that, with increased population, and increased number of anglers and commercial fishermen and consequently greater demand, it is now impossible to maintain and increase fish life, at least in the fresh waters, without the aid of artificial propagation. Evidence of this is too great for successful denial. One clear proof is that in every instance where food fishes are being propagated in vast quantities, and where nets and other devices are lawfully used, there is a more or less marked increase in the number of those fishes. On the other hand species not artificially propagated are rapidly diminishing in number.

A notable example of decrease under such circumstances is the sturgeon.

I think it is universally conceded by fish culturists that for years to come it will be necessary for Governments to

provide by law for an annual close season for nest building fishes, for a period before and during their time of spawning, and further to forbid by law, the catching of such fish until they will have reached a size and age which will assure of their naturally spawning once. Among this class of fishes may be named prominently the black bass and trout.

Huge appropriations and large areas of land for fish hatching purposes are not necessary for fish culturists for the propagation of non-nest building fishes on a scale more than sufficient to meet the annually growing demand of the market. A close season during the spawning period for such fishes is today not only unnecessary but would likely be a hindrance to effective work by fish culturists. The eggs of non-nest building fishes, are all taken from fish which are caught in nets or devices used for the market. If there is a close season, for non-nest building fishes, then, either there could be no artificial hatching or there could only be comparatively a few eggs taken from fish caught by Government officials themselves, or the close season law nullified by the Governments through the necessity of setting all the fishermen in every part of the lake to work for the purpose of catching fish to fill the hatcheries with spawn. If any number are not set to work an injustice is done them and there will be a less number of eggs for hatching purposes.

The cost of gathering non-nest building fishes of the Great Lakes and their hatching, and that on a vast scale, is comparatively inexpensive. Pennsylvania for example hatches annually over 250,000,000 white fish, lake herring, yellow perch and blue pike at a cost of less than \$5,000 a year. If it could secure the eggs it could hatch double the number without increasing its plant materially, and with an expenditure of not more than an additional thousand dollars a

*A Paper read at the Conference of the North American Fish and Game Protective Association at Toronto.

year. In order to obtain eggs of the white fish and herring sufficient to produce the number of fish named, every boat fishing out of the port of Erie, Pennsylvania, most of the boats fishing out of Port Stanley, and Port Burwell, Canada, and a large number from Ohio, waters are required. By increasing the size of the hatchery plants in Pennsylvania one thousand jars, all the boats fishing from Port Stanley eastwardly in Canada and all the boats fishing from Ashtabula, Ohio, to Buffalo could be employed. As the state of Ohio hatches herring on a vast scale and as the United States Government hatches three or four times the amount of white fish, and fully as many herring as Pennsylvania, it can readily be seen that notwithstanding a close season during the spawning period every boat fishing on Lake Erie would have to be in operation or the work of the National Government and the two States would be greatly restricted or stopped altogether. If there were a stoppage or a restriction there would quickly be a diminishing supply of white fish and lake herring instead of the great increase which has been experienced in the last three years.

Natural hatching of white fish and lake herring with the present population of states bordering on Lake Erie could not furnish a tithe of the necessary supply. The average white fish deposits wherever convenient about 30,000 eggs, of which according to eminent fish culturists, at the most only a few hundred hatch, while by artificial propagation at least sixty per cent would be brought from the egg. Under the circumstances, with the present facilities for hatching and the comparatively small expense of increasing the work, it seems to me not only unnecessary but foolish to the last degree to declare a close season for non-nest building fishes like the white fish, lake herring, yellow pike and blue pike during the spawning season; moreover, the first two are at their best for food purposes at this period. And since there is an ample supply it seems to me a wrong to deprive people of an excellent aquatic food.

It is idle for anyone to declare that there is a diminishing supply of the four

fishes named or that they are not increasing. Figures to the contrary are too overwhelming. The catch of white fish by fishermen from Port of Erie in 1903 was 36,500 pounds, in 1905, 31,969 pounds, in 1906, 113,278 pounds, in 1907, 574,265 pounds.

In 1908, in spite of a strike and in spite of the nets of one concern not being fished for some weeks, the catch was over 400,000 pounds or over four times what it was in 1906 and nearly fifteen times what it was in 1905. The catch of lake herring in 1905 was 3,060,250 pounds and in 1906, 2,696,065 pounds. in 1907, 1,883,963 pounds and in 1908 nearly 5,000,000 pounds. The herring were in such vast quantities that, from the summer of 1908 until the practically shutting down of the season there were times when more fish were caught than could be handled by the dealers. On one occasion in September the fishermen gave away more than twenty tons and every day for more than a week tons were given to people who would come after them. By the first of December the dealers had their houses packed with as many herring as they could handle.

Fishermen of Ohio and Canada also felt the increase of fish due undoubtedly to the work of the United States Government, Ohio, and Pennsylvania. Under such circumstances a close season during the spawning period appears paradoxical. What is required is not a legal close season at such times but on the contrary to give free facilities to fishermen to ply their trade and for the United States Government, the States and Canada to see to it that they have a sufficient number of hatcheries and to hatch all ripe eggs from fish that are taken in the nets and to take measures that all ripe eggs are gathered.

There is some argument for a close season, not during the spawning period, but during a portion of the summer months, say July and August. It is then that young and immature white fish and herring, especially the former, congregate on what is usually the fishing grounds in the greatest number. An open season at that time permits these young and immature fish to be caught and this too at

a time when on account of the higher water temperature and the warm weather, the flesh qualities are not as good and it is more difficult to handle them safely for the market. On a broad general princi-

ple that fish should be allowed to grow to maturity and pass at least the first spawning period, there is some sense and utility in a close season, during July and August.

Game Protective Work in British Columbia.

Moose are increasing and spreading further south; caribou have been seen in greater numbers in Cassiar; deer, except near the coast cities, appear to be on the increase, while the East Kootenay is being restocked with wapiti. However, on Vancouver Island these animals are being killed for their teeth and protective measures are necessary. The outlook for sheep is also encouraging.

A. Bryan Williams, game and forest warden in British Columbia, conveys this information in his annual report to the legislature.

Mr. Williams shows that the system introduced last year is working well and that big game is increasing rapidly. He reports that the special grant of \$10,000 by the legislature has been but little drawn upon, as the revenue from licenses and other sources comes to within \$200 of that amount. At the same time the revenue thus assured has permitted the engaging of game wardens whose work bore excellent results. The appointment of additional game wardens is recommended. It is pointed out that in addition to their ordinary duties they are frequently able to lend valuable assistance to the provincial police. These wardens are particularly needed in the country to be traversed by the Grand Trunk Pacific railroad and in the McConnell creek district, where there are thousands of caribou.

Numerous evasions of the license laws along the coast as far as the head of Vancouver island are reported. The chief offenders are from the United States, going into the province in launches or

yachts and rarely, if ever, take out a license to shoot. The purchase of a fast launch is advocated so that these poachers may be looked after. It is also suggested that it be made an offence to carry firearms without a license. The revenue from big game licenses amounted to \$7,700 during 1908.

The Indians appear to have given little trouble last year, and the keeping of the Stoney Indians from Alberta out of the province has had a splendid effect on the game on the eastern boundary.

In the East Kootenay reserve the game is increasing, and it is suggested that the reserve be made a permanent national park. The importation of European red deer and chamois is suggested. It is stated in detail that the first named have been most successfully acclimated in New Zealand.

A plea is entered for the grizzly bear, said to be nearing extermination in several districts. The animals are reported to be timid and it is suggested that it be prohibited to trap them.

Beaver have increased enormously in southern British Columbia, and in some parts of Kootenay, Okanagan, Similkameen and Kamloops, sufficiently so to be a nuisance to fruit growers. Permission to kill them under restrictions is suggested.

The report is not so encouraging as to game birds, though even in this case it would seem that conditions are improving in British Columbia as the result of the work by the warden and his assistants.



"A RED-HEADED, SLOVENLY, ROUGH LOOK-
ING BRUTE."

IN EVERY DAY LIFE.

An Interesting Hunting Incident.

During the last hunting season a gentleman was standing on the platform at Sudbury Station, Ont., and by his side was a large moose head. A passing brakeman stopped to admire the trophy and asked the owner where he had captured it. The gentleman replied that he had been hunting north of Cartier to which place he was directed by a man of the name of Miner, of Kingsville, Ont.

"Oh," commented the brakeman, "I know him. He is in camp up the line now."

"Indeed," remarked the gentleman, "I would like to see him. What kind of a looking fellow is he?"

"Who, Jack Miner?" asked the brakeman. "Oh, he's a redheaded, slovenly, rough looking Brute!"

The Big Game of Northern Ontario.

BY JACK MINER.

IN writing upon this very big question I do not wish readers to imagine that I think I am the only man who knows anything upon this subject. My sole reason for putting my own views forward are that I have hunted in many different portions of the Province during the last few years and my knowledge of the condition of the big game is not founded upon what I have read, but the actual experiences I have undergone.

At several different dropping off places between Fort William and Sudbury have I hunted and the sportsmen of Fort William are entitled to shake hands with themselves and say that they have the best hunting sections within the Province within their reach—some say upon the whole continent. Red deer are coming in from the West and multiplying very fast throughout those sections.

In the fall of 1907 an old French settler told me that five years before he saw the trace of one little deer. The following summer he saw one deer, but "to-day I see one, two, five everytime when I go back to my meadow fields." While I do not know just how long these little white tails have been there, yet I do know that they have become quite plentiful.

With respect to caribou, I saw lots of signs but no "boo." Moose however have become plentiful, having paths through the woods like cattle. The settlers snare quite a few; as a matter of fact they snare, I believe, more than they shoot. Coming east along the north shore of Lake Superior, about one hundred miles near Schreiber, we found the moose still very numerous. The deer are scarce yet in a few places and the same may be said for the next one hundred miles, or till one gets east of White River.

In 1906 I had a few days at Dalton, a flag stop about half-way between White River and Chapleau. Deer signs were encouraging and I knew it would not have taken me long to have secured my limit. I don't think, however, they can be over plentiful between the two stations mentioned because they are hunted by the sportsmen from Chapleau.

From Ridout east, one is almost sure to find fairly good deer shooting—at some

places of course better than at others.

As far as moose are concerned it is simply wonderful the way they are increasing. From east to west this increase is to be noted, and they also appear as if becoming quite civilized. Five years ago one could not think of hunting moose from the railroad. Now one can drop off at almost any place where the country is burnt, and by going back a mile or two find moose. A party of six Kingsville sportsmen, five of whom were over fifty years of age, camped about three miles east of me last fall, and though hardly two of them had ever previously seen a moose, they each got a fine moose head. Four years ago I hunted on the same ground and never saw a moose.

Last year we found things so much improved that my eleven year old boy shot one. They were quite thick on the ground and appeared as tame as a broken down automobile. It was difficult to start them and when they did start they made a noise as though the whole place was being moved.

Now don't think that the boy's father shot his moose for him. The boy shot it himself and the story is not a fake one. I might state just here that the Kingsville party had no guide and their successes were therefore due to themselves.

Just at that point the deer are not increasing. The reason, I believe, is that the wolves are big and fierce and emboldened by long immunity. One might say the fires had driven the moose in, but if that is the case, the fires, occurring as they do along the railway, would also drive them out. The fact, I think, is undeniable that moose are increasing generally all over the Province.

A trapper at Fort William told me that ten or fifteen years ago moose were not plentiful enough to be hunted at all in that neighborhood.

I believe it is very doubtful whether fifty years ago there was a single moose in the Province, and it is certainly encouraging to be able to report that they are now sufficient in numbers to allow an open season each year with good prospects of hunters obtaining a head.

The deer are coming in from the west

and south-west out of Minnesota and are going west and northwest out of Southern Ontario.

If we could only get rid of the wolves there would be good shooting all over the northern portion of the Province in less than ten years, as I veritably believe there is no part of that wild country where deer cannot thrive and do well. It any one should ask where the moose came from I can only express the opinion that they came from all directions.

The future of the moose is a subject worthy of the attention of every sportsman.

Although I don't believe in crossing a bridge before I come to it there is something more than a possibility of moose becoming too thick and falling victims to a contagious disease. I would therefore advise every sportsman desiring a good head not to delay the matter but arrange his hunt for next fall and may success attend him!

My experience in the district I hunted was that ruffed grouse were as four to one compared with the fall of 1907, and it is a pleasure to be able to make such a report. I hope they may soon be as plentiful as ever.

Personal Experiences of Two Hunting Seasons.

BY R. E. SPARKS.

THOUGH young in experience in the fascinating sport of deer hunting, I have learned that the experience of one season is no criterion of what the next may be. To illustrate:

The season of 1907 opened on Friday; I was not ready to join the hunt till the following Monday when I found that one deer had already been shot by a member of the party on the first day, and on the second day, one had taken to the water between a couple of watchers and their boat. On Monday one of the party and I were watching the same lake when a deer came in quite near to us. On Wednesday another came into the same lake while we were watching it, and on Friday, when I was watching a runway, a deer came to within about seventy yards and stood watching my red cap until shot. The following Monday a deer took to the water of another lake very near to where we were watching it. We had no sooner got through with that one and were walking up from the lake, when a big buck, on his way to the water, met us and stopped at about forty yards. On Tuesday morning we left for home while there were yet four days before the season closed.

In 1908, the season opened on Monday, November 2nd and closed on Saturday, November 14th. We went to our hunting territory better equipped than the year before and wondering how we should put in our time after getting our complement, as partridge hunting was prohibited. The opening of the season saw us on the ground ready for an early start; our

dogs worked well; game seemed as plentiful as in the previous year. We remained until the morning of Saturday, the 14th and the first live deer we saw was being pursued by a hunter in a lake as we were on our way to the station.

It is contended that there is no such thing as luck; but I for one am fully convinced that there is such a thing as ill-luck. I watched lakes and runways faithfully. Our hunting was done on two small lakes about half a mile apart. If I watched one lake, the deer came to the other; if I were at the head of the lake, the shooting would be done at the foot; or after I had watched a lake all day a deer would come in at evening.

Before coming away I could fully appreciate an oft repeated remark of our host, a farmer who has lived on his present farm for many years. His brother, who lived a few miles distant, came over for a few days' hunt. It appears they used to do a good deal of hunting when game was more plentiful. Before starting out in the morning they would speculate as to where a deer, which had been started in a certain locality, might be expected to run; or at night they would speculate as to where a deer had run which had been started in a certain locality but which we had failed to secure. These speculations invariably ended in the remark, "Oach!, there's no tellin' which way they'll run!"

However, the weather conditions were perfect; we had a good time, and we fully expect to try again next fall.

Our Annual Fishing and Hunting Trip.

BY W. HICKSON.

TO have a splendid fishing and hunting trip one season, will raise hopes in the true sportsman for a repetition of the same, if not indeed of a more pleasant and successful one the next season. Hope cheers the lover of the Rod and Gun on through his daily toil during the remainder of the season till the day for his annual trip comes round again. Then he packs his fishing tackle, his gun and his duffle and starts for his rendezvous once more in high spirits.

Such were the feelings of the writer when Bruce dropped in one fine autumn evening to see if all things were ready for our yearly trip to Lake Cetchemmacoma. I saw at once that Bruce's heart was beating with high hopes of repeating our successful trip of 1907; but I was even more sanguine and affirmed that I anticipated a much better time as the weather was ideal and there were to be four in the party.

Just as the sun gilded the eastern horizon on a beautiful Autumn Monday morning, our teamster arrived, and in a trice our whole outfit was packed in the rig and our canoes roped on securely. Then in a mild, hazy morning light the camera man took a snapshot of us as we started off for the trout and ducks.

With a flourish and a crack of the driver's whip our team dashed off, uphill, downhill, along the level road and through the valleys, and through long stretches of hard woods, where the proud, chesty partridge sat on moss grown logs in the golden sunlight, or strutted in a dignified

manner on the road before our team. Strange it was, to see these fine ruffed grouse leisurely seated on their favorite logs as our rig trundled along past them, and one certainly had "his nerve" with him, for we thought the horses would be on him before he left the road. Just at the right instant, however, with a hop, step and leap he cleared the track, ducked his head under some brush and disappeared in the woods. Bruce and Sam looked round at the writer and remarked "that fellow noticed that Ontario Fish and Game Protective

badge you are wearing and knows he is perfectly safe." Whether the boys' idea of the badge was correct or not, we could certainly have bagged three or four birds before reaching Lake Massassaga, if partridge shooting had not been prohibited.

Just after noon we arrived at Lake Massassaga and found a

logger's steam yacht, with two miniature scows, one on each side of it, laden with supplies for the lumber camps in Anstruther. The smoke was still curling up from the embers on which the men had cooked their midday meal. We added fresh fuel to it and soon had our dinner steaming, while the lumber yacht steamed off up the lake with its cargo. As soon as we had dined we packed our canoes and started for our camp ground, where we landed early in the afternoon and found everything on our island, as we left it the previous season.

Bruce as usual was brimful of energy; he selected our camp ground, the place for our beds in the sleeping camp, the



OFF FOR THE TROUT AND DUCKS.

camp poles, the place for the camp fire, the place for our ablutions, the place for the looking glass, the place for our toilet, and the big pine roots for the night's camp fire.

As soon as Bruce had done this we erected our two tents, and made our beds. After supper we had a couple of games and then rolled into the blankets and were dead to the world till morning.

Tuesday morning broke clear and summerlike and the Norway pines, the oaks and Jack pines stood out in clear relief in the bright morning sun: all Nature seemed to be on a holiday: the playful squirrel "that had not learned the fear of man" danced about on our table; the ducks all unconscious of our proximity whistled over camp; the partridge drummed in a thicket nearby; the simple woodpecker tapped at the dead limb till Bruce sent a bullet from his 22 whizzing past; the wary loon sailed on the placid waters of the lake without apparent motion or sound save the V shaped ripples he had made as he propelled himself along, and the shy mink paced along the logs and shore in quest of food.

Such was the morning as we sat in the mild, golden sunlight after breakfast arranging our tackle for trout. After we had secured bait we all started for Bruce's old stand, but the writer was the only one who landed a beauty, which we ate at supper.

In the darkness of Wednesday morning I heard Bruce call "Sam! What about those ducks?" and the reply came in a drowsy tone, "Y-e-s! I'm g-o-ing." Then there was a rustle in the blankets and everybody seemed to be tramping on my legs as I lay snugly in my cosy bed, but I was only getting my share, for I soon heard Mr. Hamilton making very

derogatory remarks about some one who had trodden on the calf of his leg, and then he said something in a low undertone which I could not well understand, though he knew what it meant quite well. Just then the flaps of our tent closed and nothing was heard save the sound of footsteps as our companions made their way to the boat. Almost immediately we were in dreamland again, but were soon awakened by "Bang! Bang!" This was the signal that there were "doings" by Bruce and Sam. The fusilade kept up till about eight o'clock and just as Mr. Hamilton and I had finished breakfast, the two came in with four nice birds. "Bouillon!" was the unanimous cry and "Bouillon" we had that evening.

In the afternoon while Mr. Hamilton and Sam fished for bait, Bruce and I set out to the east over the huge granite rocks to find Cloudy Lake, which is reported to be a great place for ducks. As we travelled on in the hot sun, we came to some wildly distorted rocks, which seemed to have been rent asunder by a struggle of the elements and Nature had been



HOW THE BOYS ENJOYED THINGS AFTER BREAKFAST.

terribly wounded in the fray: fearful cliffs stood on their edges, and nodded over us as we passed along at their bases. We got into one of these savage gorges between two of these granite mountains and wormed our way along through an indescribable tangle of bushes and vines till we emerged into a large beaver meadow, bounded on the north and west by these dreary rocks in the form of an amphitheatre. I climbed to the top of the rocks while Bruce wended his way along a deer trail through the meadow.

The meadow extended to the southeast as far as my eye could see, so I concluded

to travel north east on the top of the mountain. Before separating we agreed to meet at four o'clock at the entrance to the ravine. On I went till I arrived at another extensive meadow, around which I made my way and yet I found not "Cloudy Lake." I looked at my watch and discovered that I should be on my return trip, so at once faced about and travelled south west across the sun till I came to the appointed place of meeting. No Bruce was there, so on I went to our boat and found him near the landing. Just as I seated myself in the canoe I looked across the bay to our tents and saw a great smoke rising up near them. "The camp is on fire!" we shouted in concert, as we bent to our paddles and shot the canoe across to our island landing. Bruce jumped on shore first, as the nose of the canoe touched land, and I followed him in hot haste, and found the trees on the island on fire. The flames had not caught either of the tents, although the fire had burned up the tent ropes. Both of us seized boards and slapped them down till we got control of the fire and then drowned it out with several pails of water. A spark from our camp-fire had started the dry leaves. This is another caution to campers to always drown out every spark before they leave the camp.

In the evening we all fished for salmon and Mr. Hamilton and the writer landed eight beauties so the camp was well supplied with fresh trout after this.

On Thursday we went for a trip around the lakes. Bruce and his father brought our deep water line into play. This consisted of a steel rod and reel, two hundred feet of copper wire, with either an archer spinner or a phantom minnow for bait. Mr. Hamilton had not gone far when I heard him call out "Hold on! I have

him," and Bruce, who was acting as guide, slowed the pace of the canoe, while the end of the steel rod was quivering, as it nodded hysterically back and forth, and Mr. Hamilton was busily reeling in the two hundred feet of copper line. All of a sudden there was a swirl behind the canoe and a splash which betokened the presence of a fine salmon; he was played skilfully and then landed and admired. We proceeded on our way for a couple of miles and again we heard the signal shout "I have another" and sure enough another was played and landed. As we came to shallow water our deep sea line was taken in and we paddled along admiring the beautiful scenery of the river and the lakes till four o'clock. We now turned our faces towards camp where we landed at six in the evening and found everybody had brought great appetites

with them. Bruce always shines when a good camp fire is needed, so he built a terrible pile, and capped it with a large pine stump, with great roots sticking out from every side, resembling an octopus. The flames soon curled and wreathed heavenward from these huge pine arms, but still Bruce kept pil-



AN EVENING'S CATCH.

ing on fuel to give us better cheer, till we thought we would have to move the whole camp a couple of rods away. In his intense earnestness he stepped into the butter dish and left the print of his heel: we assured him the butter did not require any print whatever as it was of most excellent quality.

On Friday morning the boys were out again at the ducks, and returned with only one bird. While they were away a partridge came right into our camp, viewed the surroundings, then "whirred" away over to another point; then with innate boldness started to drum. A few

rounds during the day did not satisfy him, but he kept it up, nearly all night to keep us awake. We made a solemn promise that if he should do any such thing next season, we would deal out poetic justice to him.

When we needed some fresh salmon, we fished at intervals, with varying success till the day before we were to leave for home. Then all took a hand and we succeeded in getting twenty-four nice salmon to bring home to our friends. Mr. Hamilton used the line for deep water fishing and out of nine strikes he got eight fish.

Sam had found a veritable paradise for salmon, but as he had only a bass line, it kept breaking every few minutes, so he only landed three. He has found

out that bass lines are not of much use to fish for the lake salmon. Altogether we got some nice strings and enjoyed the fishing and the good suppers they made.

After having ideal weather for eleven days' most pleasant outing, we pulled up stakes on the twelfth morning and landed in Bobcaygeon at 5.15 the same evening. All were greatly recuperated by the trip and we have already decided to repeat it in 1909 if circumstances at all permits it.

Life would seem monotonous if we had not bright places in it, so when we dwell on the pleasant memories of these sportive days and anticipate some better ones that still lie in the future for us, we travel along the pathway of life with a blither heart.

Saskatchewan Fish and Game Protective Association.

A number of enthusiastic sportsmen in the city of Regina and neighborhood met on Tuesday, February second, on the occasion of the annual meeting of the Saskatchewan Fish and Game Protective Association.

In recording the work done by this young but promising Association it was stated that the committee has negotiated with the Government with a view of securing a portion of the buffalo herd which were recently placed on an Alberta reserve, and have them transferred to Saskatchewan. Communications were sent to the members at Ottawa regarding the proposition, and favorable replies were received. The introduction of game reserves has also been taken up and considerable encouragement had been extended the association. Another important feature was an effort on the part of the association to have the lakes stocked with black bass and protected by game wardens. The Minister of Marine and Fisheries had assured them that although the Government was not in a position to act immediately, investigation of the lakes would be made and fry inserted if water permitted within the near future. The prevention of spring shooting or the regulation of the same was also a matter upon which the association has given much consideration. At a previous meet-

ing a resolution dealing specifically with these matters had been passed, and at this meeting a motion, moved by Mr. Lawson, and seconded by Dr. Armstrong, was passed, that the resolution be sent to the Minister of the Interior and Wm. Martin, asking Mr. Martin to urge the Government to appropriate some suitable park in Saskatchewan for game preserving, and that a copy be sent to all members of the province, also asking that the appropriation be set aside during the present session.

Considerable comment regarding the advisability of having game reserves controlled by the Government or whether private owners should be excluded was heard. The general opinion was that native birds hovering over cultivated land owned by private parties could not be controlled by Government. If fish were only in public waters, it was considered that their quantity would decrease more rapidly.

One of the principal objects of the meeting was to form branches of the association in outside points throughout the province, but owing to the scarcity of funds it was impossible to send a representative to explain the work of the association. However, every effort will be promoted by the association to increase and spread their branches throughout the Province in the near future.

Fish and Game Protection in Ontario.

A REPLY TO THE REV. E. M. ROWLAND.

WITH deep regret I read in your issue of February 1909 an article by the Rev. E. M. Rowland, of his experience last fall while hunting in this district. I say regret—because I think you probably made an error in printing such exaggerated statements, and because of the bad effect, first on the Magazine, (of which I am a great admirer,) on the people living in the district, and on the large number who read the magazine through the country. I cannot conceive how any passably intelligent person could make such statements and expect you and your readers to believe them. I think the best way is to take the statements seriatum as they appear in the article.

The first statement is that through his cleverness he followed carrion crows to the carcasses of dead deer shot by the Ontario Lumber Co.'s Cadgers who always carry rifles with them in their wagons and take snap shots of any deer they may see. If deer fall on the spot saddles are taken into camp for the company's use, and if deer run out of sight they allow it to go.

Now such an exaggerated statement as this is out of all reason. In the first place allow me to point out to you that I have been connected in a business way with this Ontario Lumber Co'y. for the last twenty-two years and frequently visit their operations, and I can assure you positively that their cadgers do not carry rifles with them. Further the men are ordered by their foremen not to bring any portion of deer near the camp on pain of dismissal. This may appear to you to be an admission that the men do shoot deer, but let me explain. Often a settler goes into camp in September, and does not wish to lose his job and time to take in the hunting season, and may use some of the company's time to shoot a deer and take it out to his family by cadger team.

Again if the Rev. Gentleman had only allowed himself a few seconds of calm reflection he would have seen how absurd the statement was that venison is used by any Lumber Co'y. Why the very first

man who did not come up to the mark, and was dismissed by the foreman at low wages would enter an action against the company for violation of game laws, the more easily so as he can lay the information secretly so that you can plainly see that it is a matter of self protection for The Lumber Companies to keep all venison away from camp entirely. The above also applies to the Long Lake Lumber Coy., of Restoule.

His next statement is of how he was "told,"(please note the quotation) of one man who came in with seven deer. I firmly believe that the Rev. Gentleman was told a whole lot that caused many a grin to be cracked behind his back. It is not often that we are favored with such a good subject for "telling," as he appears to be and of course we must make the best of the opportunity. The absurdity of selling deer saddles by the ton! Did the Rev. Gentleman figure out how many deer saddles went to the ton, about forty I would estimate, and only one saddle to the deer, think of it! I might also say that seventy-five (75) per cent at least of all settlers living in this district, do not kill any deer at all, simply because they do not own rifles and could not use them if they had them.

His statement with reference to Beaver and Otter also bears the same mark of exaggeration. Now within a radius of a very few miles there are several colonies of Beaver, one of these within one and a half miles of this settlement. These have been there for the last fifteen years, and have not been molested, they are here for anyone to see for themselves if they wish to do so. As to the Otter there has been none offered in our four large stores that I am aware of for years past. I am well acquainted through the district and have not heard of any Otter being killed.

In conclusion I may state that his howl as to deer being scarce is hysterical. The deer are increasing all over this district, and also partridge. From all over the district come reports that the deer have not appeared so plentiful for the past ten years as they are this year, (and as it has

been a mild winter so far the deer have certainly not been driven into the lumbermen's works by hard weather or lack of food.)

I can also assure you that the Game Laws were never lived up to so closely as they have been for the last four or five years. The settlers as a whole, (with hardly an exception) are assisting the Department in Toronto, with their work of preserving the Game and Fish.

Don't think for one moment that we are fully satisfied with our Game Laws. There are a few holes yet but they are gradually being stopped up. We would like to see the dogs prohibited and also hunters who exaggerate.

My experience with the Game Wardens and Overseers, in this district is that they are hard working people and underpaid. More especially are they very busy during the hunting season. On the go all the time, visiting every hunting camp in their territory and seeing that the laws are being observed.

I must say that our experience in the past is that the wolves kill more deer than all the hunters and settlers put together. There is a swamp a few miles from here where one wolf killed eleven deer. This took place two years ago this winter. Of course this was done on the crust during March and April. We have two men trapping in this vicinity this winter, John Robertson, jr., and R. McKee. I am pleased to say that during January they secured eleven wolves, and hope they may get as many more, as wolves are the most destructive pests we have. If the bounty were raised to \$20.00 or \$25.00 more people would take up this work, but at \$15.00 it does not pay. Some people may think differently after reading above, but they must take into consideration that Robertson and McKee started to trap in November last fall, and did not get a wolf until January.

E. H. Kelcey, Capt.

"D" Coy., 23rd Regt.,
Loring, Ontario.

The Problems of Protective Work

BY CINNA

The question of Game Preserves, like every other, has two sides. Much has been said lately against preserves. Editorials have been written, and resolutions passed by associations organized for the protection of game and fish condemning them.

It would be well in the first place to look into the matter a little closely and try to find out what brought about the desire on the part of individual sportsmen for private game preserves.

In the old times, say forty years ago, when game of all kinds was plentiful, there were no game preserves, public or private, and no one thought of them. As time went on, shooters became more numerous, the breech loader was introduced, bags became much larger, and as a natural consequence, game of all kinds began to diminish year by year.

It is said and with truth, that Canadians are a sport loving people. Of all branches of sport, shooting is the most

fascinating. Its votaries, once they have caught the disease, never get over it until they die, and it is safe to say, that they all hope for a happy hunting ground in Heaven, as did their red brethren who hunted the land before them.

Now, as I have said, game of all kind began to diminish, and shooters on the other hand became much more numerous. Amateur sportsmen who went afield for upland game, or to the marshes for ducks, generally found the market hunter there before them, and their bags became smaller and smaller, until they almost came to the vanishing point.

It was this condition of affairs that made the amateur sportsman, the professional man, merchants, bankers, etc., men who had been in the habit of taking a holiday in the Autumn, spent either in the uplands after Quail, Partridge or Woodcock, or in the marshes after ducks snipe, plover etc., begin to think of a remedy for this lack of sport. What was

more natural, than that they should think of buying or leasing a piece of land and preserving it, and thereby having a little quiet sport for themselves, undisturbed by the hordes of shooters who infested every place where there was any game. Of course marsh lands being the cheapest, were the first to go. It would almost seem as if these men had committed a criminal act in providing for themselves so that they could indulge in their hobby without molestation. Of course the trouble, where marshes were concerned was that the public had had free access to these marshes, and were now sore at their being bought up. But shooting grounds like other things are governed by the law of supply and demand, viz: When a thing is plentiful and not much in demand it is cheap and easy to get, when it becomes scarce and people want it, it costs money.

I suppose it would be better for all, if all preserves were done away with, and the Powers that be, took charge of all the shooting grounds, making proper regulations for the protection and propagation of game, regulating the shooting so that each one should have a proper share etc, But this is too much to expect, in fact Governments as a rule on this side of the Atlantic at any rate, are very careless as to what becomes of the game. We have seen the extinction of several species of our game birds and animals in late years, and several others are on the verge of extinction. This being the case, can men be blamed for looking out for themselves?

The great destroyer and exterminator of both fish and game is the man who shoots or fishes for the money there is in it. To him the word "preserve" is a nightmare. To be restricted in any way calls for his loudest protest. Those who seek to stay his destroying hand are called "Bloated Monopolists" and harder names. Any legislation tending to stay his hand is class legislation intended for the benefit of the sportsmen.

The market fisherman or sportsman claims as his right all the fish and game he can take. If lovers of fish and game seek to stop his destructive work, he lifts his hands and cries they are interfering with vested rights, they are ruining business interests, and so he goes on until there is very little left either of fish or game.

Now, this is not an overdrawn statement, as anyone who has lived long enough and takes an interest in the subject can vouch for.

Take the Southern Peninsula of Ontario for instance. Many of us, not very old, can remember when our woods and fields teemed with game, and our streams and lakes with fish. What is the condition now? Quail, the only game bird left on the uplands, are so scarce that good sportsmen would not shoot one for fear of being in at the death of the last bird. Our small waters that should be reserved for the benefit of the people, are turned over to the deadly Hoop net. Our rivers allowed to be incessantly dragged by seines at a time when the fish gorged with spawn are ascending to deposit their eggs. This being the case, can it be wondered that men fond of sport and recreation, band themselves together so that they may enjoy some sport. Nor can it be proven that preserves are not beneficial, in preserving the game and fish from extinction. The number of preservers having money invested try as a rule to preserve the game. Try to save the bird that lays the eggs as it were. Not so the outsider. With him it is "Kill it or some one else will." The fact of the matter is, that in this country, we have all been on the kill, and not at all on the preserve. It must be remembered that the older settled parts of Ontario, can no longer be called a new country.

We must adopt Old Country ideas, no matter how unpalatable it may be to some, or do without game and fish.

To prove that Game Preserves are not altogether a bad thing in the community, let me tell a little story.

The Duck Club, to which the writer belongs thought it would be a nice thing to have some Quail shooting on the highland adjoining, so leased a tract of land from the farmers, stocked it with birds from the South, and for a number of years had good sport. We found that our birds, although well fed and cared for in the winter, had a habit of straying off to the adjoining land when the breeding season came around, obeying, I suppose the Scriptural injunction to increase and multiply. When the shooting season came around, the adjoining lands held as

many birds as did the preserve. Farmer's boys and others had good shooting, but whilst the club shot with care, and were satisfied with reasonable bags, the outsiders killed all they could. The consequence was that the preserve held birds when the outside grounds had been shot out. This caused envious eyes to be cast on the Club, and they began agitating amongst the farmers from whom the Club leased, even threatening them. The consequence was that a number of farmers refused to lease, although they

were well satisfied with the Club, but their neighbors and even their own sons were opposed to it, and so the Club threw up the whole thing. Of course the idea of the agitators was, that if they had the land the Club had, to add to that which they had already had, they would have doubly good shooting, but what was the actual result? Last season the writer did not hear of a single bird being killed in the neighbourhood, nor could he hear of a single bevy of quail on grounds that before held from thirty-five to forty bevies.

The Difficulty of Enforcing the Law.

A most interesting case to all lovers of fish and game protection has been reported from Sault Ste. Marie, Ont. Oliver Pouquette, who is a jobber at Mile 63 on the Algoma Central, was fined \$200 and costs amounting to something over \$228, for illegally killing deer. The case was more than important owing to the difficulties experienced by the Crown in obtaining evidence sufficient for a conviction.

The only witness, Samuel Allen, was employed in the defendant's lumber camp when it was alleged the deer was killed. After he was summoned to appear as a Crown witness he was discharged from camp and compelled to seek employment elsewhere. He managed to secure, through friends, another situation in a lumber camp but was again discharged because he persisted in telling about the defendant's conduct. When he was discharged a second time he was at a camp at Mile 51 on the Algoma Central Railway and although he had his check for his time he was refused transportation and compelled to walk through a storm the entire distance to the Soo. The walk kept him in the bush all day Friday, Friday night, Saturday, Saturday night and the greater part of Sunday. Unfavorable

weather conditions prolonged this severe test of endurance and had the weather been unusually cold it is doubtful if Allen could have reached the Soo alive. It was stated in court that the persecution of Crown witnesses deserves and should receive the condemnation of all fair and right thinking people.

The evidence for the Crown showed that on December sixth, which was a Sunday, defendant took a gun and left the camp at nine in the morning, returning at one p. m., when he sent a man from the camp to the bush. Later on the man returned with a young deer that was consumed at the camp. On the following Sunday the offence was repeated.

The defence was a complete denial and five witnesses were called in corroboration. A determined effort was also put forth to besmirch the character and reputation of Allen but without success, the magistrate holding that a serious offence had been committed and visiting it with a smart fine.

This case forms a strong illustration of the difficulties under which game wardens work for an enforcement of the law. The arrangements for the case were in the hands of Game Warden Calbeck.

"A Settler" writes from Restoule to protest against the statements of the Rev. E. Rowland, but his letter was full of personal insinuations and cannot be published. As we have shown by publishing Captain Kelcey's letter we are always willing to give both sides a hearing but letters of this kind must deal with principles and leave personal matters alone. It

does not weaken a man's statement to call him names, but it does display a poverty of argument when a reply of this kind is all that can be given. "A Settler" will have to write in a different spirit before he can hope that his writings will have any effect upon the question of the enforcement or non-enforcement of the Ontario Game Laws.

Another Strong Indictment.

BY WILLIAM PRATT.

Notwithstanding the apathy of the public, and also of the powers that be, the question of Fish and Game Preservation will not down, and "Rod and Gun" is to be warmly commended for allotting space so liberally to its discussion.

I think about two years have passed since I presumed to use your columns, so will you again kindly give me space to further discuss this great subject?

The Rev. E. M. Rowland's indictment in your February number was most timely and to the point and I am sorry you saw fit to qualify his contribution somewhat in the March number. Perhaps he could not bring absolute proof of some of his charges, yet the average hunter will take his statement without proof, having in their experience much corroborative evidence.

But I want to go further than Mr. Rowland and give facts that I can prove.

During the hunting season of 1907 I repeatedly came across a lumber camp foreman hunting Deer with dog and rifle, and without a licence, because I asked him for it. On my return home, I gave the man's name to our local Deputy Game Warden, together with dates, location, additional witnesses, etc. The D. G. W. went to Toronto, laid the case before Mr. Tinsley and the result was that the D. G. W. was instructed to do what he could in the matter *at his own risk and expense*. Did you ever hear of a greater farce? Fakirs forsooth!

Further, I had positive knowledge that the offender aforesaid had been hunting previous to the occasions mentioned, because I had met him in the woods with dog and rifle, and I can furnish information that he continued to hunt all the following winter with the result that last season we found our territory practically cleaned out.

Let me say further that I have personal knowledge that in a territory one hundred and fifty miles long by fifty wide the great bulk of the lumber camps are accurately described by Mr. Rowland. Still more, I wrote to Mr. A. Kelly

Evans giving him facts, from personal knowledge, of flagrant offences against both Fish and Game laws, asking him in the strongest possible way to help us, and after some delay he replied to the effect that he had placed my letter before Mr. Whitney and that he had Mr. Whitney's assurance that the matter would get serious consideration. More farce!

Sir, let us be candid about this question of preservation, and own up at once that the Government is all balled up on it. The previous Administrations were up a tree too, but this much can be said of them, that the necessity for vigilance did not seem so great. Now that deer haunts are being made more and more accessible by new railways and ever increasing revenue is being produced from licences, stupid apathy must take a back seat. The Lord helps us if Major Hendrie's prognostication proves true. He says "The local sentiment of every city, town, village or hamlet must be worked up to a centre, thereby giving a united voice, before our Legislature of Toronto will *ever* move outside of an *occasional, spasmodic, ill-conceived effort*". (the italics are mine.) Why! the Major actually proves the Rev. Mr. Rowland's indictment.

The long and the short of it is, neither the present or previous Governments have or had much interest in Game preservation, and if it sometimes happens that extra pressure is brought to bear from some particular spot, the only action is to appoint some needy useless hanger on, to a lucrative job of doing nothing. Of course sometimes a really good man does get the appointment, and the results of such men's work are proof positive that the appointment of a sufficient number of similar men at decent salaries would very soon solve this question of Game Preservation.

Pardon the length of this letter, I feel that I have but touched the fringe of the subject. With your permission I will take up another feature of it later.

The Quebec Fish and Game Leases

HON. C. R. DEVLIN BANQUETTED AT QUEBEC

THE local sportsmen of Quebec believe that the Hon. C. R. Devlin, the Minister of Colonisation, Mines, and Fisheries is doing his work with zeal and good effect. To mark their approval of his actions and to further closer acquaintance, as a result of which they hope for a sympathetic consideration of their requirements, they invited him, at the beginning of February to a banquet at which fish and game topics furnished the burden of the speeches.

Mr. E. G. Joly de Lotbiniere, President of the Sportsmen's Fish and Game Protective Association presided and the banquet was in every respect a marked success.

The table was in the form of a horse-shoe, and in the centre, facing the chair, was a splendid specimen of red deer peeping out of mass of shrubs and greenery, and producing a splendid effect.

After the toast of the King came that of the guest of the evening, the Hon. C. R. Devlin. The Chairman in submitting the toast, made a defence of the Quebec system of leases. He showed that while only a comparatively small proportion of the area of Quebec wild lands was under lease, the splendid protection given by these lessees, in some instances for a quarter of a century and more, was responsible for the salvation of fish and game, not only on the leased territories themselves but also over the adjacent country, into which the surplus game of the woods and fishes of the stream constantly extended themselves. He also furnished statistics of the enormous benefits conferred upon the poor settlers in the generally inhospitable parts of the country where the best fish and game clubs had their preserves. One of these clubs that he knew of had ninety guides out in the woods at one time. All of them spent enormous sums of money among the habitants, and the latter would be very sorry indeed to see a disappearance of the present system. He also pointed out the number of excellent guardians

maintained by the clubs at good salaries who had done, and were still doing so much to protect the provincial supply of fish and game. In this connection he pointed out that more protection was achieved in this manner than could be afforded by government, and it was a matter of much satisfaction to sportsmen that Hon Mr Devlin had decided to pay proper guardians good salaries for good work, and as a preliminary step, had dismissed a number of insufficiently paid men, who had been as a rule sitting all the winter through by their stoves, instead of doing the work expected of them. In very delicate terms he offered a number of amendments that he considered might, with propriety, be made to the fish and game laws. Amongst other matters, Mr. Joly de Lotbiniere referred to the sale of enormous quantities of dangerous Mauser rifles throughout the country, and urged that partridges and hares be given an entire close season of two or three years in which to reproduce and multiply their kind, and that the rules respecting tags on carcasses of big game be so amended as to check certain existing abuses.

The Hon C. R. Devlin expressed his appreciation of the compliment paid him by the sportsmen of Quebec. It had never occurred to him till that afternoon that the little dinner which he had been invited to partake of with a few friends meant a complimentary banquet to himself, and least of all, one of such importance, influence and magnitude. He was glad that their devoted Secretary, Mr. Chambers, who as he had said elsewhere was one of his greatest persecutors in the way of constantly pressing fish and game protection upon him in all its forms, had induced him to go up with him to Toronto to the meeting of the North American Fish and Game Association, where, as anticipated, the effort was made by Toronto people to dictate to the Government of Quebec the abolition of the system of fish and game protection by means of clubs holding leases of fish and game

preserves. He had too much appreciation of the work of fish and game clubs to be affected himself by any resolution that might be adopted at Toronto or anywhere else. He had believed it to be his duty to combat the idea of such dictation, and to prevent the movement for the undue influencing of public opinion in Quebec against a system that was peculiarly adapted to their necessities and condition. The clubs had done good work and he could endorse what the chairman had said of them. In fact, though no member of a government desired to depreciate its work he almost ventured to say that they had done more for protection than the government itself had been able to do. They had made liberal expenditure of their means, trusting to the good faith of the government. Was this good faith to fail them? He had asked the Toronto gentleman who had moved in this matter whether he was expected to tell the members of these clubs who had thus counted on the good faith of the government of Quebec that they had made a mistake and thrown away their money, and that he as Minister, was now about to rob them and turn them out, and he had answered his own question by simply but positively saying: "I won't do it." In the interest of the clubs themselves he had acted with what might appear to be harshness to them. In many instances, rentals had been raised as leases were renewed, and these renewals were usually for a term of five years, instead of nine or ten. If the Ontario system was so much superior to that of Quebec, why did so many Ontario sportsmen come to this province for their hunting and fishing and participate in this system of clubs and leases which some of their people were so anxious to destroy? How many province of Quebec people found it necessary to go into Ontario for their sport?

He made mention of the unprecedented large revenue of \$100,000 which had been received from fish and game by the government last year, and after complimenting the local fish and game protective association upon its good work declared that he had been indebted to it in the past for many excellent suggestions. As illustrating the influence it had exerted upon him he mentioned that

it was in line with its recommendations that the close season for moose, deer and caribou had remained unchanged, that the prohibition of beaver hunting and the sale of partridge had been extended, that contractors, lumbermen and others had been made responsible in law for the violation of fish and game regulations by their employees, and that a number of picayune salaries, insufficient to induce any man to work as a guardian, had been withdrawn from men who did nothing to earn them. In this latter connection, he frankly admitted that men could not be expected to do good work on such miserable pittances. He was a believer in good salaries for efficient services, for the laborer was worthy of his hire. He congratulated himself upon the excellent staff of officials by whom he was surrounded in his department and upon the excellent services rendered by his friend the assistant Attorney-General, Mr. Charles Lantot, in both the framing and enforcing of his legislation. He thanked the chairman for his suggestions. They would all be carefully considered. He invited the association to meet him at his office and discuss proposed amendments to the existing law, and hoped they would present a united front. He urged upon the lumber kings of the province the propriety of disarming all their employees in the woods, as a useful measure of game protection. In expressing his appreciation of the honor done him that evening, he spoke eloquently of Quebec's reputation for hospitality, and recalled his early impressions of it.

Sir George Garneau, Mayor of Quebec, was called upon to address the gathering and in well chosen phrases spoke of the duties which every sportsman should take upon himself to perform, not only to safeguard his own interests but those of the province which derived great revenue from its fish and game. Sir George spoke very feelingly of the delights of the chase and of the good work which had been accomplished, not only by the fish and game association, but also by different clubs holding leases from the government. He joined in the congratulations which had been tendered to the Minister for his efforts in the direction of better protection of fish and game.

Canadian Forestry Association.

Important Conferences at Toronto.

THE members of the Canadian Forestry Association held a two days' Convention in Toronto early in February. The attendance was large and representative, including the Governor General of Canada, the Lieutenant Governor of Ontario, Mr. W. B. Snowball, New Brunswick, the President, &c.

Earl Grey emphasized the direct bearing of forestry upon agricultural and national prosperity and the health and happiness of the people. After dwelling upon the "selfish disregard for the public interest" which had characterised the people of the United States in their past dealings with the natural resources of their country, he pointed out their present activities on these subjects. "The teaching of the people how to care for their forests is becoming the first object of the American Government. I hope it will also become the first object of the Canadian people. The forest area in the Dominion is 354,000,000 acres. By far the greater part of this is still Crown land, or in other words, belongs to the people. The question for you to determine appears to me to be this: Shall this great inheritance, of which you are the trustees, be handed over to uncontrolled individuals to be misused, without regard to the interests of posterity, or shall it be managed under careful and well considered regulations on lines which will increase the public revenues, at the same time that they will ensure a steady advance in capital value."

The Hon. J. M. Gibson pointed out that Ontario had set aside vast forest reserves though he agreed more should rightly be done in that direction. Effective fire ranging was necessary to protect the forests.

Mr. Watson, President of the Toronto Board of Trade, held that no more noble object than the protection of our forests for the benefit of future generations could be conceived. The Toronto Board of Trade were whole heartedly for forest protection.

The Hon. Sydney Fisher, Dominion Minister of Agriculture, regretted that

Canadians had followed the example of the older people to the south and had also been wasteful and reckless in the destruction of their forests. Carelessness and ignorance were great dangers, but he hoped the public awakening would lead young people to carry out the policy of protection in an efficient manner.

Canada has the greatest water system for navigation and transportation in the world, but already the water varied in depth and the channels had to be dredged, and it was feared that the facilities for ocean liners going to Montreal was in danger if the forests, which held the head waters of the rivers, were not protected.

Hon. W. C. H. Grimmer, Surveyor General of New Brunswick, described the efforts of that Province for better things. He believed in the absolute preservation of the forests. In New Brunswick great precautions were taken against fire and a new departure had been made by getting the correct scales of the timber cut.

Mr. Frank Hawkins, Secretary of the Canadian Lumbermen's Association, pointed out how intensely the lumbermen were interested in forest protection, and promised all the help the lumbermen could give in the work.

Professor McClement, of Queen's University, promised that in all the instruction at Queen's he would point out the necessity of every man subordinating his own private interests to those of the public and the future, and to some extent sow the seeds of public opinion which would prevent the exploitation of the forests in a wasteful manner.

Various suggestions were made by Messrs R. Bergerin, Quebec, A. Kelly Evans, Toronto, J. B. Laidlaw and Professor Fernow, the latter describing forestry as true patriotism, because it took thought for the future.

Mr. Snowball, in the course of his presidential address, suggested the appointment of lecturers to visit the forested portions of the country and give practical talks on forestry subjects. He further thought each Province should have the

whole of its wooded area gone over by persons properly qualified to run survey lines. Both the Federal and Provincial Governments should be urged to enact more stringent laws against forest fires and appoint permanent fire guardians on every one hundred square miles. At the head waters of every stream there should be forests reserved for the regulation of the water supply, and fish weirs should be maintained to enable fish to reach their spawning ground.

President Falconer, in welcoming the delegates to the University, dwelt upon the hopes he entertained from the establishment of a School of Forestry at Toronto University. He trusted that the students might so mould public opinion that selfishness would be replaced by a desire to help in the development of the nation.

Mr. A. T. Drummond, in a paper on "The Practical Side of the Forestry Question," suggested the establishment of a forestry bureau in connection with the Provinces of Ontario and Quebec similar to the bureau now in existence at Washington.

Mr. Aubrey White, Deputy Minister of Lands and Forests for Ontario, gave a paper on "The Forest Resources of Ontario". He gave a history of the timber regulations of the Province stating that over fifty millions of dollars had been received by the Provincial exchequer from forest and minerals.

Mr. F. C. Whitman, President of the Nova Scotia Lumbermen's Association, submitted a paper on "Forest Conditions in Nova Scotia". The cutting of timber and the output of lumber had reached the limit of reasonable production, and the increasing value of lumber had a tendency to draw altogether too heavily on the diminishing timber reserves. In Nova Scotia the province long ago lost control of its best land and now the Government was left with 1,500,000 acres of the poorest lots scattered from one end of the province to the other. A forest policy adapted to the present system of tenure was badly needed. The Government was now preparing the way for a descriptive survey of the provincial forest lands and he advocated like action by all the other Provincial Governments.

Mr. R. B. Miller, of the Forestry Department of the New Brunswick University, in a paper on "General Forestry Conditions and Forestry Education" expressed his earnest conviction that education formed the best possible means for carrying out a policy of forest protection.

On the second day Dr. Fernow read a paper on "What We Want". "We want the Governments of the Dominion," he said "to change radically their attitude towards the national property in the forests. We want the Governments to realize that there are other ways of utilizing forest properties than merely exploiting them, that a rational, properly directed, technical management is capable of securing all the value without destroying the capacity for further production, in other words, that forests can be managed as crops to be reproduced while the utilization is going on.

"Next we want the Governments of the provinces, especially the eastern ones, to realize that not less than two-thirds of their territory, and most likely more, is not fit for agriculture and only fit to grow timber. Hence, there should be a more careful distinction made in the treatment of the two situations.

"And here we come to our third and most fundamental want, efficient protection against forest fires, without which all other propositions and the practice of forestry are futile."

"To make fire protection effective in the provinces, there is lacking first, the proper attitude, next the organization, next the men and adequate expenditure, and lastly, proper morality among the people at large.

"I believe the Dominion Government and the Province of Quebec have the feeble beginnings of such an organization which only needs to be further elaborated. These two Governments have inaugurated what would appear to be the first requirement, namely, separate Government agencies to take care of the forest interests, and only an extension of their means and functions are necessary for further developments".

The reason for the scanty results of the long continued propaganda on behalf of conservative forest management, for

the delay of a vigorous reform would, then, appear to be:

Lack of realization on the part of the Governments that supplies are rapidly waning and that, hence, necessity for conservation has arrived.

Lack of realization that the forest resources of Canada can and must be made permanent, because of soil and climatic conditions, and because of its influence upon water powers.

Lack of personnel to inaugurate and carry on any forest policies involving technical knowledge.

Lack of popular knowledge, and popular interest in a question, which does not seem to concern the present.

Lack of definiteness in the propositions for reform, which must naturally differ for different parts of the country.

The momentum of existing methods of disposal of the timber which benefit an influential class of citizens, the timber limit holders, who will naturally battle for their continuance, and the natural unwillingness of Governments to make radical changes.

The Hon. Frank Cochrane, Minister of Lands, Forests and Mines for Ontario said that less timber was burned on Crown Lands per square mile than on private lands.

Professor E. J. Zavitz submitted a paper on "Waste Land Planting in Ontario".

"The Department of Agriculture in Ontario is concerned with two forestry problems, namely: It aims to assist farmers and other land owners in properly handling their woodlands and reforesting waste portions of the farm. It has also inaugurated a policy of segregating and placing under forest management the large areas of waste lands throughout older Ontario".

"The policy of putting these lands under forest management has many arguments in its favor. It will pay as a financial investment, assist in insuring a wood supply, protect the head waters of streams, provide breeding ground for wild game, provide object lessons in forestry and prevent citizens from developing under conditions which can only end in failure."

Mr. Charles Riordan, of the Rior-

dan Paper Mills Company, and representing the Canadian Manufacturers Association, read a carefully prepared paper on "The Attitude of the Paper Manufacturers Towards Conservative Forestry." In the course of the paper he said:

"The forest resources are practically all in the hands of the Governments or large industrial institutions. I do not believe that our Governments will thoroughly conserve the natural resources directly under their control, which are really the capital of the nation, so long as there is any considerable portion of them unappropriated and unexploited, because the people do not care how much of these resources is wasted or stolen so long as they feel that there is more left, that there are still opportunities."

"Only the Government can afford to handle natural resources without regard to the immediate profit from them. The industrial institutions owning natural resources must always first consider immediate profits in appropriating and exploiting these resources, so that the pulp and paper industry must first operate its timber holdings to produce present profits. That being provided for it must then operate them to perpetuate the supply, at any rate in the case of mills in close connection with their timber areas."

"The paper and pulp industry has more need of conservative forestry methods than any other industry that is using the forests, commercially, because it has the largest investment per quantity of timber used, and this investment is represented by plant that is less movable than any other wood-using industry, and also because it requires a large amount of power steadily all through the year, and this depends on the forests remaining at the head waters." The Laurentide Paper Co., the Union Bag and Paper Co., and the Riorden Paper Mills, are all employing trained foresters and spending considerable money in thoroughly investigating their timber resources and everything to do with their development, and in studying timber growth and methods of manufacturing logs. They are inaugurating the policy of marking the trees that shall be cut, and are adop-

ting rules for jobbers and foremen that are eliminating the waste of anything they can possibly use. This means making a great deal more use of the product of the forest than any other industry does.

He also dwelt upon the great importance of the question of the export of pulpwood and bespoke a definite and well considered policy by the Dominion Government on the subject.

Mr. Abraham Knechtel, inspector of Dominion Forest Reserves, described the work of the Dominion Government in the matter of forest preserves. The necessity for the work was becoming more apparent every day.

A number of important resolutions were passed, one of which was the suggestion that a Royal Commission should be appointed to investigate the entire subject and report to Parliament. It was also suggested that the several local Governments controlling Crown lands, not already having done so, be requested to withdraw definitely from location all lands at present open from location as may be found on inspection to be unsuitable for farming purposes, and that no town or settlements as yet unopened for settlement that shall be found on inspection to contain less than fifty per cent of agricultural land be hereafter opened for settlement; further, in case of lands now under licence, now open for settlement, but which are found to contain more than fifty per cent of land suitable for agriculture, that previous to opening such townships or settlement the licencee be given a reasonable time in which to take off the merchantable timber.

It was decided to appoint a committee to consider the preparation of farmers' bulletins of warning and instruction, bulletins for schools and the inclusion of elementary forestry in High school courses, and the preparation of maps and lantern slides for teaching purposes.

The association desired to impress upon the Federal and Provincial Governments the great necessity of placing in forest reserves all lands at the head waters of streams.

The delegates were the guests of the Toronto Board of Trade at a banquet,

which was attended by the Governor General, the Lieutenant Governor of the Province, the Premier of Ontario, and many other representative gentlemen.

The Governor General, in responding to the toast of his health, said it was necessary in the national interests, to preserve the forests. In the United States the destruction of the forests had cost a thousand million dollars, and it was up to Canada to take warning from that loss and stop the wanton and reckless waste of timber resources.

"What we have to do.—I have been so long among you that I say we—is to teach the children of Canada to have patriotic regard to the conservation of the wealth of Canada". The higher thought of "What can I do for Canada?" rather than "What can Canada do for me?" should be impressed upon the young.

The Lieutenant Governor who was also toasted, hoped the result of the Convention would be some practical action in the preservation of the areas set apart for forestry purposes.

Mr. R. S. Gourlay, in proposing the toast of Canada to which Sir James Whitney replied, reminded those present that we were but stewards and it was our bounden duty to consider the interests of future generations who would then enjoy a greater heritage than the people of Canada had at the present time. If Ontario allowed the misuse and overuse of its forest reserves, the whole system of water ways would suffer, and he was glad that some great action was being taken to protect the waterways. The neglect of the proper protection of the forests had left vast stretches of great wildernesses. It was a pleasure to know that the Ontario Government had taken steps to preserve the forests. Sir James Whitney said the subject of the toast was a very large one, but that fact should not deter any good Canadian from attempting to deal with a portion of it. He referred to the late George Canning, who, nearly a hundred years ago, was striving hard against the conspiracy of crowned heads against human rights, and inspired what is known as the Monroe Doctrines.

A Ladies' Moose Hunt in New Brunswick.

BY SADE M. EMACK.

ON Saturday we left Fredericton by the I. C. R. Express at six-thirty p. m. for Taymouth. Arriving there in about an hour's time we were met by one of the guides and a team and were driven to his house, a distance of some six miles, where we spent Sunday.

Early Monday morning we hit the trail for the camp which meant a journey of eight miles into the woods. Our party consisted of the two guides; Jim and Alex. Somerville, my brother Miles, known by his intimate friends as Professor, so called because from his youth up he has never hesitated to express his opinion on any subject whatever, giving one the impression that he knew as much as the other fellow and perhaps a little bit more. I made the fourth, and we anticipated a jolly time, having plenty to eat, and some liquids labelled "for medicinal use only."

The first night in camp I was disturbed by what I supposed were field mice running over the roof; imagine my surprise when on enquiry Jim told

me they were conkerokuses. I had never heard of those animals before and said so, but when I caught them exchanging grins I knew I was being jollied because I was a mere girl. That morning we were awakened by Jim's stentorian tones telling us to "roll out." 'Twas hardly daylight and both looked and felt raw and cold. For a minute how I did wish I

was back in my own little bed, but as we hustled into our clothes that feeling soon wore off and we all talked at once of what we are going to get and how large the spread was going to be, etc. It makes you feel good, even if you do come off the short end of the horn sometimes. The Professor and Jim went in one direction and Alex and I went to a barren about a mile from the camp. Alex, who is a splendid caller, performed well but to no purpose. We laid in wait several hours until the pangs of hunger became too insistent and we hiked for camp and breakfast. I would not have been a bit



AUTHORESS AND GAME.

surprised to have had indigestion after the meal I ate, everything tastes so good in the woods.

We were as lazy as possible that day until four p. m. when we all four walked to the Beaver Pond about two miles from camp. About six we got an answer. It is impossible to describe the thrills that go through you when you hear the deed whoof ! whoof ! and the rattle of horns against the trees. We could hear him coming along very distinctly until he seemed quite near, when, all at once we heard the whining note of a cow. That settled us for he would come no further despite Alex's best endeavors, so we reluctantly started for the camp. We passed a pleasant evening and were only too glad to turn in early. The next morning we packed the necessaries for a two days' jaunt and left for another camp situated on the banks of a deadwater from which it was named. Professor and I read nearly all day while Jim and Alex cooked and fussed around camp. That afternoon, we just walked a short distance from camp and began calling. About an hour later we had an answer, and were waiting with our hearts in our shoes, when, just as he was coming along nicely we heard talking a short distance away and there came into view two men from the settlement. Of course we didn't bless them, Oh ! No ! The following day Alex got up early and called about twenty yards from the camp door while we remained under the blankets. Directly Jim came in all in a flutter ; Alex had been answered. We made all possible haste and soon had the satisfaction of hearing his royal nibs. Again we were doomed to disappointment for all at once a shot rang out followed by another, and all was still. Our friends (?) of the night before. It being still early we went on about a mile beyond the camp ; Alex and Professor went to one corner of the barren and Jim and I to another. We were again answered, Professor saw him and fired. The distance was too great, however, and Mr. Moose wheeled, and was away before you could say "Jack Robinson." Wasn't it enough to drive a man to drink, so near and again so far ? We remained at that camp another day, our luck still unbroken, excepting that we got several partridges and no end of porcupine.

However we were still living in hopes as indications pointed to moose being very plentiful.

That day we set out for the home camp but about half way on a nice hardwood ridge we decided to camp for the night, even if we had only three blankets. During the afternoon Professor and Jim went for a stroll and when they came back they were full up of the big moose they had seen in dense alder thicket. He couldn't possibly have measured less than sixty-five inches, by their talk, and our hopes soared upward. Presently, however, Professor began telling of the snake he had seen and had began throwing small sticks at it until it was practically buried except its head, and it hadn't even moved. The woods rang with laughter. We rolled over and over and laughed. That certainly was the climax. Alex and I would not believe a word they said and teased them unmercifully. They couldn't, apparently, understand why we laughed but don't you think it looked suspicious ? My ! but it was jolly that evening toasting our shins before the fire. We made a lean-to with some poles and one of the blankets and with the other two and some boughs we spent a comfortable night.

The following morning Professor and Jim sallied forth with the intention of still hunting the monster moose while Alex and I went on to camp. He either did not prove as large as anticipated or had decamped, at all events they came back empty handed. The days passed much the same till Saturday, when at the dinner table I remarked that I was going to have fresh meat for Sunday dinner, if I had to walk to the settlement for it, and would you believe it (?) I made good. That afternoon about 4.30 Alex and I went to the Beaver Pond and about six o'clock we had an answer from across the pond. Presently, crash ! bang ! such a racket. The only thing I could compare it to was a team driving over a tote-road with a load of boards. We decided that he would break the record, so imagine our disgust when we heard his lawful spouse calling him back. But he was either inclined towards Mormonism or else was a bold deceiver, since he kept answering and trotting along until all of a sudden nothing but silence reigned.

Were we again to be deprived of our game? But no! Alex started to crawl along stealthily and motioned me to follow. The suspense was fierce. We expected to hear them cut and run any moment. We had gone just a short distance when we saw them both browsing by a tree. The cow was the largest I had ever seen, about as large again as the bull. 'Twas a mutual surprise party all right. I raised my rifle, a Winchester 32 Special, and let drive regardless of aim. Talk about going! I'll wager that old girl is going yet. Not so Mr. Moose. He only ran up a knoll to give me a better chance. I took careful aim this time, the bullet struck him, breaking his neck and he fell like a log. 'Twas all over but the cheering. Needless to say I walked on air back to the camp, proud as Punch. The Professor and I also had an interesting story to tell. It seems while they were lying in wait between calls they chanced to see a fir tree showing the fresh marks, evidently hooked by a bull moose. The tree was so high they were speculating on the enormous size of the moose and sauntered out to examine the tree and found that it had in all

probability been done by a porcupine or a bear. Just as they were turning aside they looked full into the eyes of a bull moose. He never moved for about five minutes during which time they were debating whether to shoot or not, Professor insisting that he was much too small for him. The argument had no sooner been decided in favor of the moose, when up trotted another chap who looked like a two-year-old. There they were, a moose on either side. Professor said it was the best thing he had ever seen, but both were much too small to shoot and they started for camp.

The following day being Sunday we took time about getting up and after breakfast set forth with only our camera as a weapon and spent several pleasant hours, the day being perfect. That evening the four of us walked to a distant barren and Alex called. Isn't it maddening the

contrariness of things? We had no less than four answers, but having a deep respect for the game laws, we could not shoot. Two of them were beauties and with one was the inevitable cow. That is what plays the deuce with moose hunting through calling, the cows are so



THE PROFESSOR AND GUIDES.

contrariness of things? We had no less than four answers, but having a deep respect for the game laws, we could not shoot. Two of them were beauties and with one was the inevitable cow. That is what plays the deuce with moose hunting through calling, the cows are so

plentiful. The temptation to shoot was great but as the old fellow said "we were game to the gizzard," and desisted.

The next morning we intended breaking camp and started on the home stretch, so Fess and Alex turned out before dawn in order to get in some distance ahead of the tote-wagon and see if they could not succeed in landing a moose, since Professor was still minus his moose although on Thursday he secured a splendid deer with a well matched set of antlers. Jim and I remained behind to pack and we were also going to set a bear trap. Such a time as we did have to get that trap sprung. My weight of a hundred and sixty pounds came in handy there. We at last got everything together and ready to start for home. How I did hate to leave. We had spent a very jolly time and all too short. The weather which had been perfect throughout our trip changed almost at once and we took our last look around amidst a downpour of rain.

Our journey out was rather eventful. We had covered about half the distance, having reached Burnt Brook, when we beheld Alex on the other side executing an Indian war dance to attract Jim's attention, since we did not cross the stream at that point but followed it for about a mile. The Professor had scarcely an hour before shot a splendid moose. It seems that they were standing in the open on the hill overlooking the brook and more out of curiosity than of any hope of being answered, Alex gave a short call. Immediately came the answer. They made for cover with all haste and ran almost full tilt into the moose, which was standing not twenty paces away. Not giving him time to

recover from his surprise the Professor, with one well directed shot from his trusty old 49 90, which struck him in the base of the ear, brought his career to a close. I managed to secure a fairly good snapshot of the moose by taking a time exposure, the day being so dark.

The day shone bright for us then, even if we could not discern Old Sol's smiling face as this last success only added more firmly to our deep-rooted belief that good old New Brunswick can't be beat when you're after game and fun and you have the good fortune to have with you two such all round good fellows as Jim and Alex.

Our triumphant entry into civilization was somewhat marred by the breaking down of our overloaded wagon when within half a mile of Jim's home, and our dinner. This mishap caused us later in the day to catch a glimpse of the rear end of our train and to call forth some rather explosive language from the Professor, since we were forced to spend the night and part of the next day in the settlement, but as Jim said "Twas all in the huntin'."

That evening in talking to a native sport we were rather amused by his earnestness in telling of his experience of the day before of having fired fifteen shots at a big bull moose and failed to bring him down, so the Professor with a sly wink at me remarked that it took a full box to shoot a moose, and he answered "By heck! I'll know next time."

Several days after our arrival home I was deeply gratified to learn that the strenuous effects of Jim and myself in setting the trap had been rewarded by a handsome black bear, the skin of which Jim sent in.

Mr. John Bowron, of Innerkip, Ont., called at Rod and Gun office some time ago with a couple of curiosities. The first was a baggage ticket from Niagara Falls to Woodstock issued fifty six years ago at a time when his father first came to Canada. The ticket is still in a good state of preservation and show that meals could be obtained at Niagara Falls N. Y., for twenty five cents. The sec-

ond was a piece of copper weighing about one pound taken from a mine discovered by his father near Chapleau, which mine has been worked for fifty five years and is still working. Unfortunately for Mr. Bowron his father disposed of his share in the mine for a comparative trifle and the piece of copper is now the only portion of the mine still in the family.

Game Protection In Southern Ontario.

The annual meeting the Essex County Game Protective Association was held at Kingsville on Feb. 15. There was a large and representative meeting of the most prominent sportsmen in Essex County present. Mr J. T. Miner, Kingsville, the well known big game hunter, occupied the chair. Dr. Anderson, M. P. P. for South Essex was present.

The chairman opened the discussion by referring to the great danger in using high power rifles indiscriminately in thickly populated districts, such as Essex County in the hunting of wild geese, etc., and thought there should be a clause in the Game Act prohibiting such use. C. I. Pastorius, Harrow, thought it would be a good thing to prohibit the use of high power rifles in such places. F. H. Conover, Leamington, thought it would be a difficult matter to deal with so as not to unnecessarily restrict those who were fond of rifle shooting. W. A. Smith, Kingsville, pointed out that the difficulty was already met by the present law which made a man responsible for the consequence of doing any act the probable result of which would be to endanger human life, but thought a clause might be put in the Game Act, as a specific warning to rifle users, and he moved, seconded by Thorfin Wigle, Gosfield South, "that the use of high power rifles in closely populated districts where the probable consequence would be to endanger human life, be prohibited." This was carried.

The Chairman next took up the question of black squirrels and thought the few that were left should be saved from extinction. Elihu Scratch, Kingsville, hadn't shot a black squirrel in ten years, but thought the small remnant should be protected by a close season. R. Eede, Gosfield South, spoke of the care he had taken to try and preserve the black squirrel on his land but the poachers got them. There should be a stringent law to stop the poacher. He thought there should be a license of \$2 on the gun. He moved, seconded by A. G. Adams, Gosfield South, "that shooting of black

and grey squirrels be prohibited for ten years." Carried.

The Chairman referred to the quail as the bird that affords 90 per cent of the sport in Essex County. Raising pheasant on public lands was a failure as they were too easy a mark for "Johnny Sneak-em." He had liberated many pheasants without satisfactory results, as the poachers got them. With quail it would be different. W. A. Smith, Kingsville, referred to the present unsatisfactory condition of affairs regarding quail, both so far as the farmer and the quail hunter were concerned. He admired the patience of the farmer who submitted to the endless procession of quail hunters crossing his land in the quail season. The greatest menace to the existence of the quail was the snow storms of winter. Something should be done in the interest of the farmer with quail land, by the quail hunter who liked to kill quail but did little to preserve the crop. He proposed that both classes get together at a meeting to be held at once and form an association for the purpose of looking after quail in bad weather and making such regulations as would limit the shooting on Association lands. Shooters who did not own quail lands should be asked to contribute an annual fee to create a fund out which farmers who would do so would be paid for their time in feeding the quail in bad weather. He would limit the shooting to one or two days a week during the open season, but would not favor shortening the season. H. Milkins, Leamington, thought Mr. Smith's suggestion a good one but he did not go far enough. He would tax the gun 50cts to \$2. Quail hatcheries should be started the same as with fish. The natural cover of the quail was gone. The Deputy Game Wardens were not paid enough. The paltry sum of \$400 paid the Game Warden was not sufficient. It would be a serious matter to shorten the quail season.

There were lots of sportsmen in Leamington, but how many of them were there that day. Thomas Pastorius, Kingsville, thought the shooters as a whole should be considered. He would deal with the

quail question through the local association. He did not think the season should be shortened, and moved, seconded by W. Wilson, that the season be left as at present. It was moved as an amendment by W. H. Townsend, seconded by Byron Wigle, that the quail season be the last 15 days of November. The amendment was carried.

The Chairman approved of a license on the gun. Quail must be protected. The first old fashioned winter would wipe them out. The Hungarian partridge was a better bird for this country than the pheasant. Jabez Spencer, Gosfield South, thought rabbit hunting the greatest danger to the quail. Byron Wigle, Gosfield South, did not agree with Mr. Milkins. He was a farmer and thought the season should be shortened to two weeks. F. H. Conover thought the protection of quail an important matter. He would tax the gun and limit the bag. The present season, was late enough on account of the snow. The Chairman would limit the bag each day and for the season. Alex. Cascadden, Kingsville would limit the bag for the season to 12. He moved, seconded by Elihu Scratch, "that the season limit for quail be 12 birds." Lost. Moved in amendment by W. A. Smith, seconded by T. Pastorius "that the limit for quail for the season be 50 quail." Carried. The Chairman, "Don't go away with the idea that the law will protect the quail. There must be something done to feed the quail" and he proceeded to explain at length how he was feeding quail this winter. Also, the necessity of protecting the quail from hawks attracted to the feeding racks by the presence of quail there.

The present season on rabbits was spoken of as very unsatisfactory, because so many hunters made an excuse of hunting rabbits to slaughter quail which could be easily tracked and potted on the snow. It was moved by J. Spencer, seconded by Dr. Jenner, Kingsville, that the open season on rabbits be limited to the month of November. Carried. A short open season on doves was advocated, and it was moved by Dr. Jenner, seconded by J. Spencer, "that the open season on doves be the same as for quail. Carried.

The open season on ducks was then

taken up and discussed. F. H. Conover thought it necessary to shorten the season to protect ducks at this point. Ducks commence to come down about the 1st October. There would be an objection in the North in making the season later, but he would distinguish between Essex, Kent, Lambton and Elgin and the more northern portion of Ontario, so far as the duck laws are concerned. Ducks could be retained here if there were a later season. It was not duck shooting when you had to go out in your shirt sleeves. When the Club controlled Pelee Point not a shot was fired until the 15th of Oct. and the ducks remained there and could be fed. He would have the season for these four counties open on Oct. 15th.

It was moved by F. H. Conover, seconded by J. Spencer, that the open season for wild ducks and water fowl in Essex, Kent, Elgin and Lambton be from October 15th to December 31st, both days inclusive.

A motion by F. S. Moss, seconded by J. Spencer, to prohibit the use of the pump gun at game in Essex, Kent, Elgin and Lambton was voted down. The suggestion to allow spring shooting was not entertained as it was considered a step backward in the matter of game protection.

The Chairman was discouraged about the game law on deer because the Legislature took no interest in it. He was surprised to hear Chief Game Warden Tinsley say that beaver was on the increase when at the same time he could have shown him 100 beaver houses empty. If Maine with 40,000 square miles of territory had a revenue of 12 or 15 millions from her game, what should Ontario get, with seven times as much territory? There were no game laws in Northern Ontario, at least no enforcement of the laws there.

Fire Ranger Colin Wright denied the statement that the game laws were not enforced in Northern Ontario. The laws were enforced as well as it was possible to do in that country. The greatest offenders were the big head hunters, wealthy Englishmen who have guides, and slaughter the moose indiscriminately in order to get a record head to hang up on their wall.

Dr. Anderson, M. P. P. addressed the

meeting. He was glad to be present and hear the arguments and discussions. He considered it his duty to be present. We must remember that Ontario was a large Province. For game protection purposes it might be divided into zones. He would do the best he could to carry out the resolutions passed. Would keep in communication with the leading sportsmen and do what he could to help. He loved a true sportsman, the man who will not take a pot shot or shoot out of season. He was pleased with such men as Miner and Watson, who raise game birds. He was glad no action was taken as to Spring shooting as he did not approve of it, although it looked a little hard to see the Yankees shooting and not to be allowed to do the same. Regarding the deer, the members from the North would look after that. He would be pleased to see the quail increase. He didn't like rabbit shooting with bird dogs. He was afraid when rabbits were hunted in this way, many quail were shot. He

thanked those present for the very satisfactory meeting and promised to do all he could for the people of South Essex. On motion a hearty vote of thanks was tendered Dr. Anderson for coming to the meeting.

C. I. Pastorius, Harrow, spoke briefly on the deer question. He did not think the deer laws were properly enforced. He would not advocate a total prohibition of deer shooting as that method had not increased them in this County.

The meeting then proceeded with the election of officers as follows:—President Elihu Scratch, Kingsville; Vice-Pres., J. T. Miner, Gosfield South; Secty-Treas, W. A. Smith, Kingsville; Executive, F. H. Conover, Leamington; C. I. Pastorius, Harrow; Joel Whitney, Gosfield North; M. B. Squire, Windsor; M. W. White, Paquette.

Moved M. C. Fox, seconded by F. H. Conover that the next meeting be held at Kingsville unless the executive otherwise decided. Carried.

Net Fishing in Ontario Rivers

Strong Objections to Renewal of Licences.

For several years fish protectionists have strongly urged the abolition of net fishing in Ontario rivers and two years ago they were so far successful as to induce the Department of Fisheries for Ontario to stop the issuing of net licenses in the Thames River. This victory, which was repeated the following year, was largely neutralized by the granting of permits, but the improvement in the fishery was so marked that protectionists have urged the entire abolition of licenses and permits for net fishing in the Thames, Lake St. Clair, and Mitchell's Bay. The burden of this contest has been undertaken by the River Thames Angling Association, of London, and the local association, having joined the Ontario Forest, Fish & Game Protective Association, have received the hearty and united support of the Provincial Association.

An important meeting to protest again-

st any re-issuing of licenses was held in London on February thirteenth under the presidency of the Hon. Adam Beck, a member of the Ontario Cabinet, whose address was notable for his strong expression of opinion in favour of the policy of prohibiting netting on all inland streams of the Province. He held that the fish were one of the most important sources of wealth in the country and he was entirely in favour of preservation and protection. He emphasized the attractions of the game fish for sport and the importance of the food fish for the whole people.

Mr. Marshall Graydon, barrister, of London, argued that as the fish belonged to the Crown everyone should have equal rights in fishing. No licenses should be granted and the fish permitted to go up the river to their natural spawning beds.

Mr. N. H. Stevens, President of the

Chatham branch, testified to the improvement in fishing in the Thames since the seines between Chatham and the mouth of the River had been removed. Many of the farmers on the banks of the Thames could not afford to go to Muskoka to fish but if the nets were removed from the river they could fish along its banks with just as much pleasure and success as in Muskoka. Over twelve hundred farmers and residents around Chatham, Blenheim, Wallaceburg, Dresden, Dover and adjoining districts had signed petitions opposing the issuing of licenses to net fishermen.

Mr. William Smith, South London, described conditions at Port Stanley and urged that action should be taken there. Gill nets had been used in the lake, within one hundred yards of the pier, taken up in broad daylight and nothing said to the fishermen.

Mr. A. Kelly Evans, Secretary of the Provincial Association, dwelt upon the depletion of the fish in Lake Ontario owing to net fishing in the Bay of Quinte. He had heard all the arguments the net fishermen could advance and in reply to them he had only to point to the city of Toronto, where 340,000 people had been deprived of their food fish owing to the netting which had been allowed.

Mr. Caleb Wheeler, of the Chatham branch, wired that at an informal meeting held in the city square that afternoon of farmers and mechanics a resolution had been passed demanding equal fishing rights for all.

Mr. L.H. Smith, Strathroy, apologised for non-attendance and added: "Netting at the mouth of the Thames is an outrage on nature and a wrong to every man who wets a line in that river."

On the motion of Mr. J. A. Cottam, seconded by Mr. Marshall Brady, the following resolution was unanimously adopted:

"Whereas many years ago workmen and citizens in general at London, Chatham, and all along the valley of the Thames River were able to catch by hook and line a plentiful supply of game fish and food fish;

"And whereas, owing to the increasing number of licenses, issued for net fishing

and the extremely large quantities of fish caught by nets, these natural rights and inalienable privileges of the people along the River Thames were destroyed and fishing by hook and line was practically done away with for many years;

"And whereas, during the last two years no licenses have been granted for net fishing in the River Thames, and in consequence of this farmers, mechanics, laborers, and all classes have been able to provide food for their families by hook and line and any man out of employment have been able to earn from \$5.00 to \$12 per week by the sale of such fish to poor families at low prices, and affidavits to this effect having been presented from numbers of such men;

"Now, therefore, be it resolved that we the citizens of London, Chatham and the Thames Valley, in mass meeting assembled, do strongly oppose the issuing of any permits or licenses for net fishing in the river Thames;

"And further, be it resolved that this meeting strongly urge upon the department the vital necessity of additional restrictions upon and possibly the entire prohibition of net fishing in Lake St Clair;

"And further, be it resolved that a copy of this resolution be presented to the honorable, the minister of public works and fisheries by the Hon. Adam Beck, the chairman of this meeting."

A conference was held at Chatham on the following Tuesday between the anglers and the net fishermen with the result that the latter offered, if seine licenses were granted, to sell to Chatham and London dealers at two cents less for soft fish and three cents less for pickerel than to American dealers. It was decided to forward the proposal to headquarters at Toronto.

The delegates from the Angling Association, Messrs. James Weldon and W. Smith, were against net fishing on any terms, and under the circumstances the whole matter had to be referred to the Department at Toronto. It is hoped, however, that the interest roused in the subject on the part of the public will secure beneficial results, in greatly curtailing, if not abolishing, not only licenses but also permits.

The People's Game and Fish Protective Association of Nova Scotia.

THE semi annual meetings of the People's Game and Fish Protective Association of Nova Scotia were held at Halifax on February 10th and proved the most important and enthusiastic meetings in the history of the association. One of the most pleasing features of the gathering was the absolute unanimity of those present upon the more important issues which came up for discussion and the very apparent determination to make the views of the association effective. Over forty delegates were in attendance, nearly every branch being represented.

In his Presidential address Mr. H. D. Ruggles said: "I am glad to meet so large a number of delegates representing so many of our branches throughout the Province. This is the sixth meeting of our Provincial association and will, I believe, prove to be the most important yet held, by reason of the questions that are coming up for consideration. I congratulate the Halifax Branch upon the splendid success which they have had in starting their organization, and also our efficient secretary and his zealous assistants, on being able to establish a branch in this important centre.

Every Province of Canada and almost all, if not all the States of the American Union, have associations such as ours, and for the same objects. It is interesting to note that the greatest number of these have arisen within the last ten or fifteen years, showing the great awakening upon the subject of game and fish over the whole continent during recent years. To Nova Scotia belongs the unique honor of having the first society of the sort in British America—the Game and Inland Fishery Protection Society established in this City in 1853. This society in point of age is only exceeded by one in all North America—the New York Association for the Protection of Game established in 1844.

When the questions which now confront us shall have been settled it will, I think, be advisable to enlarge the number

of the objects for which this association exists. First among these I would suggest forest protection. This we have always insisted on by all our members; as without forests our game and fish would perish, our streams dry up and our soil become as barren as has that of many countries, in other parts of the world, once noted for their fertility. My experience is that very few forest fires are the work of fishermen and the time of year in which hunting is done almost precludes the possibility of hunters causing any. The greater number occur from the attempts of people desirous of clearing meadow or other land.

The question arises here whether those owning forest land should not be obliged to leave all trees under a certain size standing. In other words should not the maxim that a man must so use his own land as not to injure his neighbor or the public, apply here with greater force? A strip of country from which everything has been cut is almost in as bad a condition as if a fire had run over it, and the rainfall must be sensibly diminished as a result of it.

Another object which should be incorporated in our constitution, is the protection of song and insectivorous birds. The farmer and the whole community are indebted to our little feathered friends more than most of us realize. Birds annually destroy thousands of tons of noxious weed seeds and billions of harmful insects. From a report recently received from the Department of Game and Fish of the State of Alabama, I quote: "A noted French scientist has asserted that without birds to check the ravages of insects, human life would vanish from this planet in the short space of nine years. He insists that insects would first destroy the growing cereals, next would fall upon the grass and upon the foliage, which would leave nothing upon which cattle and stock could subsist.

The possibilities of agriculture having been destroyed, domestic animals having perished for want of provender, man, in

his extremity in a barren and desolate land, would be driven to the necessity of becoming cannibalized or subsisting exclusively upon a diet of fish. Even granting that only a portion of what the eminent Frenchman asserts is true, it is easy to learn from his theory that birds are man's best allies and should be protected, not only on account of their innocence, bright plumage, and inspiring songs, but because they render to the farmer valuable assistance every day."

In the State just named the 4th day of May in each year, has at the instance of the State Game and Fish Commissioner, been set aside to be celebrated in the various public schools as "Bird Day." This date was fixed upon on account of its being the birthday of Audubon, the great naturalist and bird lover. While I would not wish to add to the number of subjects which our children are required to study I would suggest that teachers in our public schools should not fail to include among the principles which they instil into the pupils' minds that of protecting and preserving our song and insectivorous birds. For this purpose I think a Bird Day might be established with great benefit to this Province.

The State of Alabama is an object lesson to our own Province. Previous to 1907 game matters were in much the same condition as here. The revenue from game amounted to only about \$1,000 a year. During the succeeding year it rose to \$20,000 as result of efficient management, a small resident license and fines for infraction of the law. Give us in Nova Scotia a resident license of \$1 00 for big game and a small fishing permit for non-residents (coming to the the Provincial instead of the Dominion treasury) and Nova Scotia can at least duplicate these figures.

With a revenue such as this, think of the possibilities in the line of game protection! Our forests could then be policed and game and fish protected; a Provincial game farm could be established, new species introduced and the Province made a veritable sportsmen's paradise. In the introduction of new species of either game or fish, great caution should be exercised and no species should be allowed to be brought into the country without permission from the Department.

I refer to such cases as the introduction of rabbits into Australia and the introduction of varieties of fish which might destroy our brook trout.

Among the different branches I might notice that during the past year a move in the right direction has been made, in the introduction of wild rice into our lakes and streams, as food for waterfowl or pheasants. Other branches have devoted their funds especially to patrolling the woods in search of law breakers. On the whole a better state of things existed throughout the Province in respect to game matters than ever before.

I have lately been in correspondence with a firm of naturalists regarding the black game, a magnificent bird of the grouse family, of which it is the second largest in size. This bird inhabits countries similar in climate to our own. Its food is the same as our grouse and I believe this is the ideal bird for introduction here.

But it is useless for us to discuss schemes such as these for the preservation of game and the propagation of new species until the people's rights in respect to game and fish have been ascertained and secured. If we are to be told that, notwithstanding the fact that our money has been used to protect and preserve the game, it belongs to the owner of the land on which it may be found, and that the fish matured from spawn, which our money has placed in the rivers and lakes, belongs to the man who owns a narrow strip along the water's edge, then our only care should be to see that our money is no longer diverted in this direction. And, if, after thousands of dollars of our money have been spent every year to protect the forest land of others from fire, we are trespassers in going upon the lands so protected in search of our game and fish, then our only duty is to see that public money is not henceforth used to protect private property. As a people's association we demand on behalf of our members and of the whole people of Nova Scotia, a statutory declaration that the game and fish of this Province belong to the Crown. All other objects could be dropped until this is secured. Having accomplished this the game and fish will do their share in forest protection.

It matters not what the laws of other lands may decree ; game and fish are not by nature subject of private ownership. In this land no feudal baron with a band of cut throats at his back has ever been able to make his will law ; and game laws that were the outgrowth of feudal oppression are not applicable to the conditions that exist in this country. The time is ripe for action ; we will brook no delay.

In the event of the refusal of our demands one course is still left open to us—organization. This should have received more attention in the past instead of wasting time in the discussion of comparatively unimportant matters. Before the present meeting of this association has ended I trust you will take steps for an immediate increase of our membership in existing branches and the organization of every part of the Province in which branches do not now exist. Already we number our members by the thousand. One month of faithful work by an efficient organizer will place us in such a position numerically that our just demands can no longer be refused. If necessary we must secure a fund by private subscription to defray the expenses of an official organizer.

The interests of the farmer, the sportsmen, the hotel keeper and merchant are identical in this matter ; and the heritage in game and fish that we received from our fathers it is our duty to preserve and transmit entire to our children.

The most important item of business was the adoption of the following :

The petition of the undersigned here by sheweth :

Whereas the people of Nova Scotia have, since its first settlement, enjoyed the privilege of free hunting and fishing in the uncultivated lands of the province, and have thereby, as we believe, acquired at least a prescriptive right therein ; and the said privilege has in our opinion been the cause of keeping many in the province who would not otherwise have remained ;

And whereas, wild animals and fish are not in our opinion, either morally or legally, the subject of private ownership, not being appurtenant to the land or affixed or belonging thereto by nature ; and laws of

other countries tending in any way to confer on the owners of lands the sole right to the game and fish thereon, arose at a period when might alone was right and popular rights were unheard of ;

And whereas the big game of this province, once scarce, has become abundant through the efforts of the government and of private associations, and not through any act of the landowners, whose dams and sawdust have depleted our fisheries and whose lumber gangs have slaughtered our game in large quantities ;

And whereas for a long time past a grant of the public money of this province has been annually made for the protection and preservation of our game and the introduction of new varieties, and the public funds have been used to re-stock the streams of the province, and the greatest injustice would be done to our people if they should now be deprived of or prevented from taking their share of the game and fish which have thus been preserved and increased through their efforts and with their money ;

And whereas, for the protection from fire of the wild lands on which said game and fish are to be found there is an annual assessment made upon the people, amounting to many hundreds of dollars annually in each municipality.

And whereas, doubts have arisen as to the legal rights of the people and landowners of this province, respectively, in regard to game and fish, and we believe that a statute should be passed declaratory of the law on this subject ;

Your petitioners therefore pray that the legislature of Nova Scotia at its present session do amend the Game Act by adding thereto a section declaring the game and fish of this province to belong to the Crown and giving to residents and non-residents the right to take wild animals and birds in their natural state and fish (except in artificial ponds) in any uncultivated lands of this province, subject to any restrictions as to licenses or otherwise in the said Game Act contained.

The petitions were printed and placed in the hands of the delegates for circulation before the meeting adjourned.

A resolution was also passed unanimously in favour of a resident big game license of \$1. A petition will be circulat-

ed asking for legislation to make this resolution effective.

The question of the sale of game was the subject of considerable discussion. While the sentiment of the association was strongly in favour of prohibiting the sale of game it was feared that the mass of the people were not yet awake to the necessity for such a measure and to press for it at this time might prejudice the association with the people whose support is absolutely necessary to the accomplishment of its scheme for making the hunting and fishing free to the public. There was also some opposition to including moose meat in the prohibition. It was decided to defer the discussion of this matter until the annual meeting.

A resolution was passed reaffirming a previous resolution calling upon the local government to resume control of the inland fisheries. The enforcement of the fishery regulations in Nova Scotia is, and always has been, in most districts a farce and in some a scandal. It is felt that with the local government in control more direct pressure could be brought to bear for the better enforcement of the law.

As the funds available for game protection are entirely inadequate for that purpose it was the opinion of the association that the government should increase the appropriation for this purpose.

H. D. Ruggles, President; Frank W. Russell, Secretary; and Rev. D. B. Hemmeon were appointed a committee to present petitions to the legislature.

The following committees were also appointed: To watch legislation: The Secretary, Mr. T. F. Tobin and Mr. E. H. Armstrong, M. L. A. To revise constitution and by-laws: the President, R. S. McKay and Mr. A. D. Johnston. To confer with the Lumbermen's Association to endeavor to secure their co-operation in the protection of the forests fish and game: Mr. G. W. Stewart, Dr. Breck, Rev. D. B. Hemmeon, and Dr. Moore.

Following along the lines of the President's address notice was given of a motion to change the title of the association by inserting after the word "Fish" the word "Forest" making the proposed name "The People's Game, Fish & Forest Protective Association of Nova Scotia."

The Halifax Branch in conjunction with the Waegwoltic Club entertained the visiting delegates at a smoker at the Waegwoltic Club House on the evening of the 17th.

The association has added three new branches, Halifax, Shelburne and Barrington, since the annual meeting and it is hoped that a number of others will be established in the near future.

The first fruits of the endeavor to secure Provincial support for the petition was seen at a meeting at the Yarmouth Board of Trade when Messrs. E. W. Jarvis and Roy S. Kelley were present as a delegation from the Game and Fish Society. Mr. Jarvis presented the claims and importance of the protection of the game and fish of the Province in a most convincing manner, giving facts and figures to back up his assertions. He asked for the countenance and support of the Board to the Game Association in their work.

Mr. Kelley summed up Mr. Jarvis, argument in the following paragraphs:

That in order to raise a fund for the proper protection of game a fee of \$2.00 should be required of all residents of the Province who go in search of big game.

The cow moose should be protected at all seasons.

That a license fee smaller than \$30 (say \$15) should be charged non-residents for the privilege of shooting small game only.

The gaining control of our inland fisheries by the local government, and establishing hatcheries so as to increase and make more generally distributed this valuable attraction to tourists.

That legislation should be enacted that will assure to the people of this Province for all time the privilege they have hitherto enjoyed of entering wild lands for the purpose of hunting and fishing.

That out of the revenues for licenses and otherwise, paid game wardens should be appointed, whose duties should include Forest protection as well as Game protection.

On motion the Game Society was assured the hearty support of the Board in their work of preserving the game and fish for the people of the Province.

Physical Culture.

Laws of Exercise Continued—Baths Etc.

NO. V.

BY FRANK E. DORCHESTER, N. S. P. E.

PRESUMING that you have perused my previous articles on this subject, you will remember what was said on mind concentration. *Unless each exercise is gone through in such a manner that full and hard (as possible) contraction and extension takes place, with the mind playing on each muscle as it comes into play; your work will lose most of its value.* To make muscle and gain health, you must use the mind.

If I may depart a little, I will also assure you that owing to this mind and will force being so used one is not only bodily and mentally benefited, but hitherto weak willed men will surprise their friends by a new and added ability to say "NO" when necessary. Will power is increased wonderfully through this mind concentration and exertion of will force.

Too little is known and understood of the power of exercise. To the thinking man, our muscles themselves must appeal, and inform him that much depends on them. The fact that we have a mind as well as a muscular body, surely implies that both are needed, therefore neither should be neglected. Such a surmise is mere logic. As a matter of fact, if you will study your physiology manuals, at the same time applying the principles found therein, to your muscles and their relation to the brain, I feel sure you will have much food for reflection.

Brain power—*morality*—spirituality, all are so bound up with good healthy muscles that they form a perfect whole.

The brain being the commander of the human forces, is it so strange that weak muscles can be strengthened by an exertion of mind over matter?

Unfortunately, although Canada has many institutions calculated to develop the muscles of her sons, these institutions, or those who run them, often go all round the main point without seeing it. The *mind* must be employed, not so particularly on time, style or prettiness of an action but on the muscle doing

that action, so that each effort shall be fully felt by the muscles. Work as though lifting heavy weights, not in wheezy spasms, holding the breath, or anything so foolish, but a full, free movement contracting each muscle fully in turn, at the same time breathing deeply and regularly.

I have already advised at what times before and after meals to exercise, but for those who cannot obtain back numbers, I will say, never exercise until two hours after, and from fifteen to thirty minutes before, meals.

We are generally strongest at about twelve mid-day, but this is an inconvenient hour to exercise. Before breakfast is probably best for most people. Before going to bed is a good time for those who prefer it. This depends on a person, his or her occupation, and what time they have to get to business or leave the same.

Exercise in the morning keeps one fresh and awake all day, but if forced to do the exercises at night, it will probably be equally beneficial. To quote a pupil recently. "Since I started your exercises, which I do nightly, I can wake much earlier each morning." However, the embryo athlete will soon find which is the better as to convenience or feelings.

Presuming the time selected be morning. Jump out of bed. Take a number of deep breaths before the open window, as explained elsewhere. Then go through your exercises, governing each one with the mind.

After the work, allow yourself to regain your breath, if breathed. Then get into either your cold bath, or take your cold sponge down, whichever you choose, follow with vigorous rub all over with coarse towel. Dress quickly, do not let the body chill.

If after cold baths are taken, any chill is felt, or the reaction is not good, you had better try tepid baths.

Of course all the foregoing instructions are given to average healthy persons. It

is impossible to go into individual cases here. In weak cases—cases above ordinary strength, curative work, all these necessitate individual particulars before any one could give instruction.

The bath is an important item to the athlete, as indeed it is to all. Hot baths should be taken twice a week, not less than once a week at all events, when possible. A good sponge or loofah will get the dirt out, and do more for health than the average observer would imagine.

The skin is one of the principal outlets for the waste matter of the body. The perspiration tubes, i. e. the pores which carry off this waste being somewhere about 7,000,000 over the skin of a person of average height, if the skin is not cleansed, the consequences may be guessed. Every groom knows his horse's skin must be smooth and glossy if the horse is healthy. In such a case we may well take the lesson, and be sure we are benefitted as much or more by having our skins clean.

The skin of those who bathe frequently is more sensitive, the cutaneous waste is carried away as the skin is more active, heat and cold are borne better, and a general lightness and buoyancy is felt. When the waste of the system is carried away and the body is freed from these poisonous matters, growth is assisted, and nutrition is unimpeded. How necessary then is the bath!

Those parts exposed should be washed at least night and morning. Those who cannot get a morning bath, can swill the body down with a sponge or flannel. After the bath the rough towelling.

Some experts say one or two exercises to start warmth would do good. As a matter of fact, vigorous towelling is exercise in itself. Then again if you are in good health, you will feel a glow directly you put your clothes on after the drying. Sandow dresses immediately after the bath without drying. This will do no harm as the water is carried outwards through the clothes if flannel is worn next the skin. At first, however, getting into one's clothes whilst still wet, makes one feel uncomfortable for a few moments.

Personally I pin my faith to cold or tepid bath (optional) or sponge down every morning. Warm or rather hot

bath twice a week and daily washes. This would suit all. Besides these, never neglect your teeth. Keep them clean.

If the reader is desirous of excelling in strength, or at some particular sport, believe me, home exercise will do more than anything to give you the necessary foundation—and a foundation of rock at that, one that will outlast the years and help you into a well preserved old age.

In some cases it may be found that a small biscuit, taken in the morning before exercising, will give the necessary stand-by required by some persons. Otherwise a mouthful of water gargled in the throat should clear the mouth—Never take anything heavy, preferably nothing at all.

When there is food in the stomach to be digested, the stomach requires all the blood possible to assist in the work. By exercising after a meal, the blood is drawn from the stomach, and may thus cause dyspepsia.

The reader may already know a good system of home exercises, which perhaps has not had the desired effect. Ask yourself if you have worked at them properly—as explained before—under proper mind control.

Those who do not know any suitable exercises, will find from time to time that I give an exercise. These will be found to be running one or more to each article, and at the end of the series you will have a set of exercises, which if followed out on the lines laid down in these articles, will be found to be surpassed by none for results.

Always start low and gradually increase number according to the difficulty or necessity of each exercise. Once you have returned to health, with a fine muscular physique, you can keep fit with fifteen minutes daily of *Mind governed exercise*.

Do not expect to see a great difference in a day or two (although a difference may be possible) for as a rule you must have patience. In a month you will be surprised at the result. Always remember that if health and strength could be gained easily—especially great strength—it would be common, but it is a force which raises you above the ordinary and *what is worth having is worth working for*. This

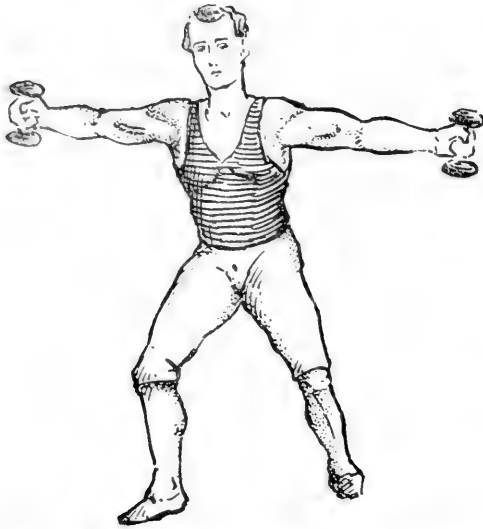

Figure badly drawn, body should be more erect, chest out, right leg well to front, arms in perfect line of shoulder.

so called work, however, will early become a pleasure.

Whenever you are doing your exercises you can feel that you are doing a duty—that of keeping mind and body ready for emergencies.

If you are inclined to take up a sport, or form of athletics — say gymnastics ; take my advice and do a few months home exercise properly first and I will guarantee five times the results at a much quicker pace.

Before giving another two exercises, I must tell you about what size bells to use. A man of twenty in good health can use three pound to five pound bells dependent on his physique. Under this two pound bells. A young boy under fourteen one pound bells. And ladies may start on from three-quarter pounds to one and half pound bells, or even something merely to grip in order to assist the muscular control.

The next exercise for this month is as follows :

From attention i.e., figure erect, arms at side. Now (1) commencing to take a deep long breath, same time raise arms rigidly out straight in front of chin: (2) Still continuing the deep intake of breath throw arms wide open to line of shoulder. same time lunging with right foot to the

full stretch of leg. (3) Now return arms to front in line of chin, same time commence to expel the breath also returning leg : (4) Return arms to side and exhaust the breath. (Repeat left leg.) See figure.

To put it shortly, Nos. one and two are taking in the breath (one deep breath,) Nos. three and four are to expel breath i.e. When arms rise and open breathe in. When arms lower or close, breathe out.

If the preceding exercise is done ten or twelve times a day great benefits will soon be felt.

Another exercise, which is very simple, is also very fine in constipated cases, es-

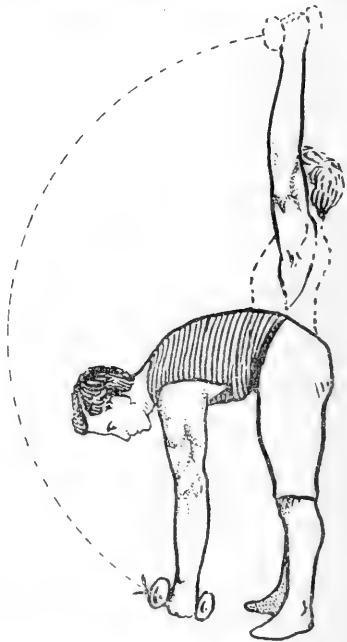

Hands above head, reach down and touch floor—repeat.

pecially if done with the other.

Attention ! Swing arms up in straight line over head, look upward. Now bend down and try to touch toes. Return to upright position with back well hollowed and chest out. Repeat this from eight to twelve times. See figure.

Those readers who have the preceding exercises should do all of them every day. They will do you good. None of them are very picturesque, but all are body-builders, if done properly.

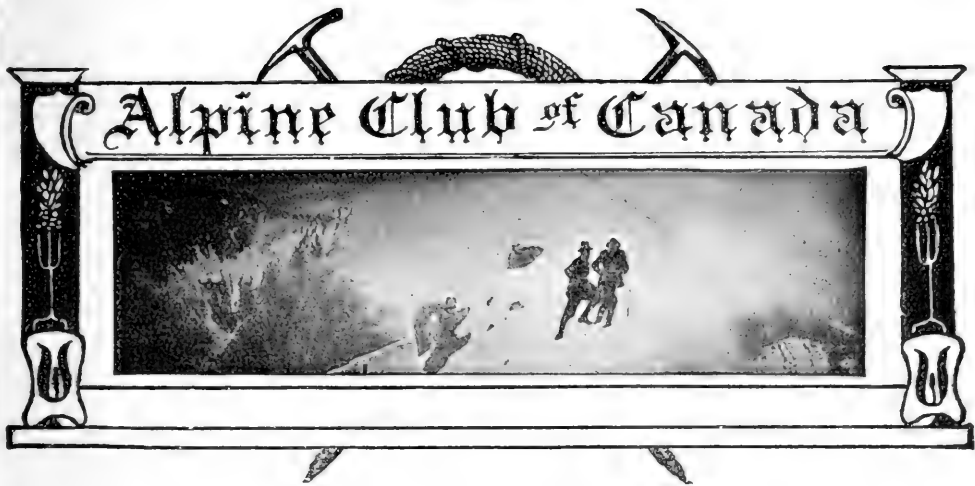

Alpine Club Notes

It is expected that the Club house at Banff and the permanent summer camp in connection with it will be ready for occupation by members from the 15th of July next. The Executive Committee will now be pleased to receive notice of those who contemplate taking advantage of the opportunity offered to enjoy camp life on one of Banff's most beautiful spots. Accommodation is limited to thirty. It is advisable that applications therefor should be made as early as possible so that suitable dates for intending visitors may be arranged.

If the accommodation be fully taken up it is likely a maximum stay of two weeks for each guest will be established, at the expiry of which time it will be necessary to move on to one of the other camps to be operated during the summer months. The rates will be practically the same as at the annual general camps that have been already held.

Members intending to make a trip to the Rocky Mountains this summer should rendezvous at the Club's headquarters at Banff, where the fullest information will be supplied for proposed expeditions and all possible facilities offered.

At Banff will be found on our own grounds all the delights of camp life that have been experienced at the previous camps and, in addition, a comfortable Club house for general assembly purposes. A detailed circular containing

full information will be issued in May next. ■

Owing to the great Exhibition to be held at Seattle, in the State of Washington, this summer all Canadian and American Railroads are making especially low rates to the Pacific Coast, giving generous stop off privileges at all our mountain resorts. It is possible that members may thus obtain even lower rates than they have before enjoyed.

It is proposed this summer to make a special feature of the Alpine attractions of the Province of Alberta contiguous to the Great Divide.

Spring is upon us and the dreams of summer holidays among the mountains must be turned into plans. Members who have done any climbing at all know how necessary an ice-axe or an alpenstock is. Any member who intends to be in camp and desires to procure one or other should write at once to the Executive Secretary, S. H. Mitchell, box 167, Calgary, Alberta, stating his requirements. It is impossible for the Club to guarantee the exact cost. Hitherto the price of the ice-axe has been \$5.00 and of the alpenstock, \$1.00. The ice-axes

have to be procured from Switzerland and an early order is necessary. They will be in Canada by the time the climbing season opens.

Even more important than an ice axe is a sufficiency of nails in the boots. The Club will have some to sell later in the season, but if they can be procured locally the heavy cost of mailing will be avoided. It is better that these should be put in the boots before leaving home, as delay and consequent annoyance can thus be avoided.

The Club's official photographer, Mr. Byron Harmon of Banff, Alberta, has issued a very fine set of stereoscopic alpine views, some of them showing members climbing at the Rogers Pass Camp. Any members ordering through the Club's Executive Secretary, can obtain these for \$1.50 per dozen. There are two dozen in the set. The usual cost of stereoscopic views is \$2.00 per dozen. The views have been obtained through much climbing and hard work on the part of Mr. Harmon.

It is still somewhat early for ladies to spend all their time out of doors. The Club house will have big rooms and spacious varandahs. There will be a big demand for suitable cushions. Here is an opening for many of our lady members to show that they are skilled in the use of the needle as well as of the ice-axe.

On the evening of 30th January, Mr. and Mrs. Frank Yeigh were at home to the local members of the Alpine Club in their house in Toronto. Among the members present were: Miss McLennan, Dr. J. A. Campbell, Mr. and Mrs. J. Watt, Mr. Cowdry, Mr. C. H. Mitchell, Mr. Symington and Mr. F. M. Nicholson. Professor Coleman came and brought his photos and some beautiful water colour sketches illustrating his recent travels in the neighbourhood of Mt. Robson.

Most readers of this section of Rod and Gun will have noticed the ascent of Mt. Huascaran in the Andes by Miss Peck, described in the January issue of Harper's Magazine. One of her guides, Rudolf

Taugwalder of Zermat, was badly frozen on the descent, subsequently losing his left hand, and most of his left foot, his remaining right hand being seriously maimed. He is thus at the early age of 41 incapacitated from earning his living at his trade, and seriously handicapped in any other calling. The American Alpine Club made an appeal for aid in this piteous case "from all those who have experienced the courageous help, the fidelity and the unselfish devotion of Swiss guides." The Executive Committee of the Alpine Club of Canada voted the sum of \$25.00 to this fund, a contribution which was much appreciated.

The "Mountaineer" the organ of the Seattle Mountaineer's Club has been added to the list of exchanges. Among the objects of the club, which is auxiliary to the Mazamas are: To explore the mountains, forests and watercourses of the Pacific Northwest, and to make frequent expeditions into these regions. The get up of the magazine is exceedingly attractive. It is issued quarterly.

The Librarian would like to remind members that the Club library has room for many more books. Among books that are desired are: Palliser's Journal, The Alpine Journal, vols. I to XVI, the Ascent of Ruwenzori, by the Duke of the Abruzzi, the Matterhorn, by Guido Rey, the complete Mountaineer, by Abrahams, and many others. From time to time articles of interest to mountaineers appear in the magazines and newspapers. It is impossible for the Librarian to see all or even many of these. If every member who read an article of this kind were to send it to the library an interest-collection would soon be formed and the articles of lasting interest could be bound in volume form. It has been suggested that a scrap book of amusing engravings, drawings, etc., relating to mountaineering might be formed and kept in the library. It would be a boon on wet days. The Librarian or the Executive Secretary will gladly take the matter in hand.

The Hon. Frank Oliver, Minister of the Interior, has presented the Club with a

copy of the Atlas of Canada, published by the Dominion in 1908. This invaluable work contains not only maps, geological and historical, but many tables of statistics, weather charts and information of all kinds. The Minister could not have made a more acceptable or useful gift.

The Executive Secretary has received a letter from a gentleman interested in orchids throughout the world. He wishes to enter into correspondence with some one familiar with the native habitat of our Canadian alpine cypripediums (Lady's slippers), so as to procure a few growing specimens to enable him to do some hybridizing with some he now has. Should any members desire to correspond,

the Executive Secretary will be glad to give them the full address.

A cablegram of greeting from the youngest to the oldest of the Alpine Clubs was sent in December. The annual meeting of the Alpine Club of England is always held during the last month of the year, followed by a banquet at which it is in order to "praise famous men and the fathers that begot them." The Alpine Club of Canada is second to none in admiration of the heroes of the past and of the great deeds of the present generation. It was felt that the kindest way of evidencing this was by way of cablegram, which was acknowledged in a courteous and cordial letter of good wishes for the prosperity of the Canadian Club.

Izaak Walton's Will.

FEW of the many curious literary relics which have come under the hammer recently have been of greater interest than the original probate of the will of Izaak Walton. It is in excellent preservation, and bears the seal of the Court of Canterbury. The original will in Walton's wonderfully clear handwriting at the age of 90 is preserved at Somerset House, London, and its provisions evidence the kindly and simple nature of the immortal author of "The Compleat Angler."

The will, which is dated August 5, 1683, is prefaced by the following words:—

"In the Name of God, amen. I, Izaak Walton, the elder of Winchester, being this present day in the ninetieth yeare of my age, and in perfect memory, for which praised be God, but considering how sodainely I may be deprived of both, doe therefore make this my last will and testament as followeth. And first, I doe declare my beliefe that there is only one God, who has made the whole world, and me and all mankinde; to whom I shall give an account of all my actions which are not to be justified, but I hope pardoned, for the merritts of my Saviour Jesus. And because the profession of Christianity

does, at this time, seeme to be sub-divided into Papist and Protestant, I take it to be at least convenient to declare my beliefe to be, in all points of faith, as the church of England professeth. And this I doe the rather because of a long and very trew friendship with some of the Roman Church."

After various bequests of land and houses to members of the family the testator wrote:—

"I doe alsoe give five pound yearly to be given to some maideservant, that hath attained the age of twenty and one year (not less), and dwelt long in one service, or to some honest poore man's daughter that hath attained to that age, to be paid her at or on the day of her marriage; and that what money or rent shall remaine undisposed of shall be employed to buy coles for some poore people that shall most need them, in the said towne; the said coles to be delivered in the last weeke in January or in every first weeke in February; I say then, because I take that time to be the hardest and most pinching times with poore people; and God reward those that shall doe this without partiality, and with honesty, and a good conscience."

OUR MEDICINE BAG

Letters from Mr. John Arthur Hope's wolf camps in Northern Ontario, received early in February stated that up to that time four wolves had been secured and it was believed four others had been covered by a heavy snowstorm. Mr. Hope was jubilant over the results having convinced sportsmen from the States that wolves are to be found in our Northern woods and that they can be killed in mid-winter hunts. He has carried conviction home to New York and Philadelphia sportsmen by procuring them pelts which they have taken back with them to those cities. The Philadelphia men in particular were gleeful because their fellows laughed at them when they set off and declared they were going to Canada "to seek the impossible." The couple of pelts taken home for mounting will convince even the most sceptical. The New York men were enthusiastic over their experiences and expect, if the camps are re-opened next winter, to double and treble the number of hunters from that centre.

With a view to effectively protecting the black bass, maskinonge and speckled trout fishery in the Province of Ontario an Order in Council has been passed prohibiting the sale and export of these fish for a period of five years from the 30th of May next. It is provided, however that any person from a foreign country having an angler's permit may take back with him a lawful catch of two days' fishing.

Mr. W. W.—writes stating that as bear stories appear in order he wishes to make a small contribution. The greatest fright of his life was received through a bear upon which he came suddenly a few years ago. He started for a tree with the bear in full pursuit. As he was

scrambling up the tree in all haste the bear made a spring and catching the heel of his boot tore it completely off. This incident induced renewed exertions till safety was achieved in the tree top and hallooing from that point brought friends to the rescue. They succeeded in driving away the bear and allowing Mr. W— to return home for which mercy he was devoutly thankful.

During a flood at Port Hope, Ont. at the end of February J. G. Elliott, foreman in the office of the local Times, is reported to have caught two fish in the office. It is a pity that the species of the fish was omitted from the story.

At a meeting of the Yarmouth branch of the People's Fish and Game Protective Association of Nova Scotia, Mr. Allen Bethune, Cedar Lake, and Mr. W. S. Uhlman, Carleton, advocated the protection of cow moose throughout the Province.

The name of the writer of the open letter to Mr. E. Tinsley, which appeared in our March number and was inadvertently omitted is Mr. W. J. Moodie, Berlin, Ont. Mr. Moodie takes a keen interest in the subject of fish and game protection.

The Duke of Bedford has presented a small herd of yaks to Canada. The animal, whose home is in the colder parts of Thibet, Northern Asia and Europe, is useful both as food and as a fur-bearing animal and an attempt will be made to domesticate it in the western sections of Canada. The herd will be placed on the Central Experimental Farm at Ottawa. The experiment is being tried at the suggestion of Mr. Ernest Thompson Seton, the naturalist.

The Conservation Congress held at Washington at which representatives of Canada, the States and Mexico joined in consultation arrived at some important and far reaching decisions which have been laid before the members of the parliaments of three countries. On forestry matters it is recommended :

1st. That an inventory be taken of forest resources.

2nd. The creation and maintenance of large forest reservations under public control.

3rd. Public ownership of forests supplying the head waters of streams.

4th. Greater precautions by the government against forest fires.

5th. The placing of all lumbering operations under a system of rigid regulation.

6th. The private owners of lands unsuited to agriculture, once forested and now impoverished or denuded, should be encouraged by practical instruction, adjustment of taxation, and in other ways to undertake reforestation.

7th. Excessive taxation on standing timber privately owned is held to be a potent cause of forest destruction by increasing the cost of maintaining growing forests, and it is endorsed that the taxation of timber land be separate from the taxation of the timber growing upon it, and be so adjusted as to encourage forest conservation and forest growing.

On water powers the report is equally outspoken. The public interest requires public control. The government control of minerals is recommended and the suggestion is made that the President of the U. S. invite a world conference on the subject of the conservation of natural resources—their inventory, conservation and wise utilization. There is little doubt of such conference being held and of wide results following. Canada has yet so many undeveloped natural resources within her own control that her interest in this matter is vital.

Six youths of Hamilton, Ont., taking advantage of a fine Sunday in February, went down to the bay to spear fish. While busily engaged in this occupation, Inspector Kerr appeared on the scene, confiscated their spears and other para-

phernalia and told them summons would follow. One of the youths was so frightened that he fell through the ice and was rescued with difficulty. Ultimately they were all allowed to settle with the loss of their tackle and fish and a payment of five dollars each.

Mr. A. C. Pratt, M. P. P. for South Norfolk in the Ontario Legislature, has reintroduced his bill for prohibiting deer hunting with dogs throughout the Province. Mr. Pratt has long been opposed to this practise and introduced his bill last year but without definite result. It may be mentioned that, with the exception of Quebec, where hunting with dogs is allowed for a portion of the season, Ontario is the only Province in Canada where dogs are now permitted in deer hunting.

It is proposed during the Spring of this year to import some Mongolian pheasants for liberation on the mainland of British Columbia near Vancouver. Judging from the manner in which other imported game have multiplied it is believed that, with rigid protection they will become quite numerous in a few years.

From Edmonton comes a story of a wounded deer charging a hunter. Edgar Waters, a former resident of London, Ont., was hunting at Gambier Island and while in a little gully, with a narrow opening, its only entrance and exit, came suddenly upon a deer. The animal dashed up the cliff in a vain effort to escape. The hunter fired, the first bullet breaking its left hind leg, the second, as investigation afterwards proved, going through the top of its heart, and a third breaking a horn close to the skull. The animal kept on its flight, in the course of which it charged right on to Mr. Waters and inflicted a painful injury to his arm. A point blank shot in the brain finally dispatched the infuriated buck.

Mr. Llewellyn Hall, of Peterboro, Ont., on a return journey from British Colum-

bia, stopped off at Fort Francis, Ont., for a moose hunt. Accompanied by a guide he explored the region of Rainy Lake and was fortunate enough to run into three moose. He fired three shots at the largest one hitting him with the first, missing his second shot and bringing him down with the third at a distance of two hundred and fifty yards, as the moose was running through the woods. The moose weighed one thousand pounds and the antlers had a spread of forty-two inches from tip to tip.

At a meeting of the local branch of the People's Fish and Game Protective Association of Nova Scotia held at Yarmouth, a report was read from Chief Game Commissioner Knight, giving a list of moose reported killed during the season of 1908. The following were reported from the different counties:

County	No.			Sex Given
	Killed	Bulls	Cows	
Annapolis	106	52	48	6
Colchester	29	11	14	4
Cumberland	21	12	4	5
Digby	42	20	21	1
Guysboro	61	35	22	4
Hants	17	6	10	1
Halifax	151	72	62	17
Kings	15	8	7	0
Lunenburg	12	6	5	1
Pictou	12	5	5	1
Queens	47	28	12	7
Shelbourne	30	18	10	2
Yarmouth	47	26	20	1
Totals	590	300	240	50

There were about 100 more reported than during the previous year. More reported in this case does not necessarily mean more killed, 1907 being the first year hunters were obliged to report the killing. It is known that quite a number not being familiar with the new law did not report.

During the hunting season in Ontario for 1908, the Canadian Express Company carried 2348 carcasses of deer, with a total weight of 264,308 lbs. The season included a period of fifteen days between November 1st and November 15th inclusive, and the figures show an increase of

181 carcasses over 1907. All of these shipments were from points in the northern division of the Grand Trunk Railway System, the heaviest shipments being made from Burk's Falls, Haliburton, Huntsville, Kinmount, Powassan, Scotia Junction, South River, and Trout Creek. These figures give, however, only an inadequate idea of the number of deer killed during the open season, as each hunter is allowed two deer on his license and as from eight to nine thousand hunters were in the district, it is probable that 10,000 to 12,000 deer were killed during the season. This is estimated from the fact that a large number of deer are eaten in the hunters' camps, and a great many are transported by the settlers by other means than through the railway.

Both parties in the Canadian Federal House are agreed upon the necessity for action in the direction of conserving the natural resources of the Dominion and a decision has been arrived at for increasing the numbers of committees so as to include those investigating matters relating to our fisheries, forests, mines, waterways and waterpowers.

Conferences between the Dominion and the Provincial authorities with regard to the international fisheries have been held at Ottawa. It is understood that the Provincial authorities, particularly those of Ontario, are anxious that the regulations to be made under the international treaty, shall conceive the rights of the various Provinces. The difficulties of treaty making are much increased by the various considerations which have to be given to Provincial as well as Dominion rights.

The following report from Mr. Ed. T. Loveday, Ontario and Quebec Fishery Overseer and Deputy Game Warden, will be good news to sportsmen; "In the Gatineau and Pontiac countries and in the district from thence to North Bay there is no doubt that deer and big game generally are on the increase now, despite the fact that more sportsmen are visiting these territories every year. Universally good sport was enjoyed by those who

IVER JOHNSON

SAFETY AUTOMATIC REVOLVER

We point to the difference between the positively and absolutely safe Iver Johnson Safety Automatic Revolver and the imitation near-safeties. They have some device added to them to make them near-safe. The safety feature of the Iver Johnson Safety is the firing mechanism itself—not some spring or button device to pull or press. That is why you can, in perfect safety—not near-safety—kick it, cuff it, knock it, or

HAMMER THE HAMMER

"SHOTS," our booklet, tells all about it in a plain, simple way, so you can't go astray on the SAFE revolver question. Send for it—FREE.

Iver Johnson Safety Hammer Revolver

Richly nickeled, 22 calibre rim-fire or 32 calibre center-fire, 7.50 (Extra length barrel or blued 3-inch barrel, or 38 calibre center-fire, 3/4-inch barrel, - - - finish at slight extra cost)

Iver Johnson Safety Hammerless Revolver

Richly nickeled, 32 calibre center-fire, 3-inch barrel, or 38 8.50 (Extra length barrel or blued calibre center-fire, 3/4-inch barrel, - - - - - finish at slight extra cost)

Sold by Hardware and Sporting Goods dealers everywhere, or sent prepaid on receipt of price if dealer will not supply. Look for the owl's head on grip and our name on barrel.

IVER JOHNSON'S ARMS & CYCLE WORKS, 157 River Street, Fitchburg, Mass.

New York: 99 Chambers Street. Hamburg, Germany: Pickhuben 4.

San Francisco: Phil. B. Bekeart Co., 717 Market St.

Iver Johnson Single Barrel Shotguns and Truss Bridge Bicycles



hunted in these districts in the fall of 1908. The farmers are becoming educated to the fact that game and fish protection is in their best interests, and not only are the laws obeyed but they are in most instances actively assisting the wardens."

That Ontario and Minnesota will soon join in a great co-operative game preserve scheme to prevent the extermination of the moose, the red deer and other game animals now present in comparatively great numbers in the wooded regions lying on each side of the three hundred mile boundary line between Lake of the Woods and Pigeon River by setting aside a great tract of land as a preserve, is the belief of Mr. Arthur Hawkes, the Canadian delegate to a series of conferences held in St. Paul, Minneapolis and Duluth. Mr. Hawkes carried with him the hearty good-will of Hon. Dr. Reaume, the Minister of Public Works in the Ontario Cabinet, and the assurance that Ontario was very desirous of entering into

any reasonable co-operative scheme by which the rapidly disappearing moose could be preserved for all time. The conferences were all of a harmonious nature, and the Minnesotan delegates were very well pleased with the expression of interest shown by Ontario in the game preserves proposition. On the return of Mr. Hawkes, the Ontario committee was augmented by the addition of Mr. W. A. Preston, Mr. J. J. Carrick, Mr. H. A. C. Machin and Mr. Kelly Evans, Secretary of the Ontario Forest, Fish and Game Protective Association and arrangements were made for a meeting with the Ontario Government to which a deputation from Minnesota has been invited.

The gospel of conservation of the natural resources of the country has gone so far that the Dominion House of Commons unanimously agreed to the appointment of a committee, to deal with fishery matters, and it is hoped that one of the speedy results of its work will be to ensure a more plentiful supply of Canadian fish for Canadian consumers.

A recent copy of the Poughkeepsie News—Press contains a full account of the formation and work of the Clove Valley Rod and Gun Club. The conditions in the State of New York are very different from those in Canada, but Canadian sportsmen are interested in what their fellows are doing elsewhere. They are also concerned in the efforts made to conduct the work of propagation and protection in every way and they sympathize with such efforts whatever form they may take. Dutchess county, N.Y. has suffered like many other places, from over fishing and over shooting and in particular the beautiful Clove Valley lost its one time abundance of fish, bird and animal life. Mr. L. M. Palmer jr, spent a summer vacation there and was never satisfied as the summers came round without repeating his visit. The great decline in fish and game touched him deeply and after hard work he succeeded in forming a club which has taken charge of a preserve. In six years Mr. Palmer has himself expended some fifteen thousand dollars in raising pheasants and fancy game birds. By the Club over fifty thousand dollars have been paid out in purchase of land, erection of building, payments for leases etc., the major portion going to the farmers from whom the game rights were obtained. An allied organization, the Clove Spring Trout Hatchery, purchased the stream, put in a fish hatchery and arranged to raise 60,000 trout, half being brook trout and the other half rainbow, brown, silver and golden trout. They have widened and deepened the stream and mean later on to raise every known species that will hibernate in those waters. Both fish and game experts have been engaged and Mr Palmer elected President of both organizations. Mr. C. A. Dykes, who is also one of the members, is a fish and game expert and has given special attention to the hatchery. We quote the second by-law as best expressing the objects of the organization: "Its object shall be to purchase and lease lands and water within the state of New York and to foster, protect and preserve game fish and game birds and animals and especially to do so upon or in lands or waters owned, leased or controlled by the Club for the enjoyment and benefit of the members

thereof." Although the enjoyment and benefit of the members is put forward as the object of the Club's endeavors, it is contended that the results of the protection it gives is felt throughout a much wider area than its own preserves and enjoyment and benefit is consequently conferred upon a very much larger number of people than are included within its membership.

So bold have the wolves been on the Gatineau this winter that a pack of eight approached near enough to Mr. Thomas Garvin, of Hull, book keeper in one of the lumber camps of the Gilmour and Highson Company, to allow him to shoot the two leaders. It is stated that the men in the camp had to be on the lookout for them even while at work.

The Perth branch of the Ontario Forest, Fish and Game Protective Association continues to do good work in enforcing the law. They recently organized an inspection of the lumber camps in Frontenac county with the result that over \$200 were gathered in through fines for infractions of the law. A correspondent commenting on these facts asks when sportsmen will realize that the present laws are good if only enforced? "Enforce, enforce and educate—as you are doing through the Magazine—but still *enforce*." The branch owes much to its energetic hon. secretary, Mr. A. C. Shaw, of Perth.

Four boxes of undersized pickerel shipped through to New York were seized at the Grand Trunk depot at London, Ont., on the evening of February 23rd. Inspector Weldon, who made the seizure, stated that the traffic had been going on for two winters, and only a few nights before the seizure no less than twenty-five boxes went through. Mr. Weldon stated that he had met fishermen of Chatham who knew the traffic was illegal. The seized fish were distributed amongst the charitable institutes of London and the Inspector declared his intention of seizing all further illegal shipments.

“253 Unfinished”

Was the remarkable **Worlds' Amateur** record of an **A. H. Fox Gun** in the hands of Joe Kautzky, an **Amateur**, at Jewell, Ia., on November 27th and 28th last. The same man, with his “Fox,” also won the “Smith Cup,” making 50 straight at 18 yards, and shot through the second day's program without a miss.

The A. H. Fox Gun

is the gun that takes the trophies. It is *perfect* in balance; simple in construction; reliable in operation; *more* than usually strong, and the closest, hardest hitter of all. Experts everywhere pronounce the “Fox” **“The Finest Gun in the World”**

Ask your dealer to show it, or write us for Catalogue and descriptive matter.

THE A. H. FOX GUN COMPANY
4692 North 18th St., Philadelphia, Pa.

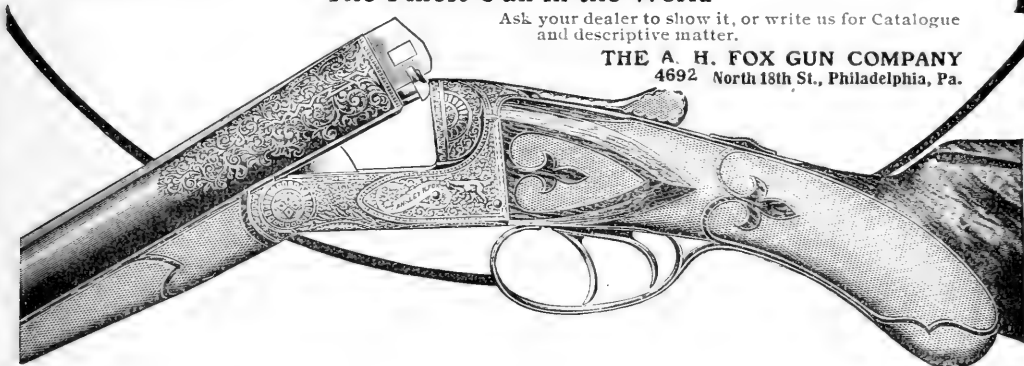

A thrilling experience, surpassing even those gone through in the life of a war veteran, recently fell to the lot of B. C. Sprague. Going down the Stewart River, British Columbia, on a raft of logs his floating home grounded on a sand bar, only a foot and a half above the water and two hundred feet in length. For ten days he was held a prisoner, two streams of ice grinding down on each side of his temporary home. All he had was an axe, a little food and two heavy coats. It was a long, trying wait for the river to close and freeze solid but at length this was done and release came. At that time food was exhausted and it was a famished and worn out man who arrived in camp after a trial exceeding anything he had known in war.

The Winnipeg people have failed as buffalo breeders and what was once the second largest herd in the Dominion is now practically extinct. The cause is said to be neglect and improper pasture. Contrary to the general belief these animals require care in confinement and

their care will repay trouble. This is shown by the success which is attending the herd at Banff. It is a great pity that Winnipeg, with the fine park system the city possesses, could not have done better for the buffaloes. The recommendations of the Superintendent were not acted upon by the Council, with the result that the great attractions of the herd are now lost to the city.

The question of the prohibition of the sale of black bass in New York State is of great interest to Ontario people, and particularly those residing on or near the St. Lawrence. The New York State League of Sportsmen has declared in its favor and the New York members of the North American Fish and Game Protective Association have pledged themselves to work for its insertion in the laws of the State. In the meantime some objection is being taken to this course by the guides of Cape Vincent, N. Y. and others, who have adopted their view, ask why the people should be deprived of the right to purchase good

Canadian Guides

Pleasure Seekers

Wishing to spend a month 'midst the
Greatest, Grandest and most Sublime
Scenery in the

Canadian Rockies

Will consult their interests by corres-
ponding with

ROBT. E. CAMPBELL
BOX 454, CALGARY, ALTA.

The Oldest Established Guide and Outfitting
Business in the CANADIAN ROCKIES

GRIZZLY BEAR

Sportsmen, with ambition to add one or two
Grizzly Bear to their list of trophies, can be absolutely
sure of doing so if they will come to the north-east
Kootenay country in British Columbia at the proper
season—months of May and June. Parties can be
fully equipped by the undersigned. For complete
information address

M. Dainard, Guide and Outfitter, Golden, B. C.

CEETEE UNDERWEAR

GUARANTEED UNSHRINKABLE

CEETEE

PURE WOOL

MADE FROM LONG SOFT FULL-
LENGTH FIBRES OF AUSTRALIAN WOOL
ALWAYS ELASTIC & COMFORTABLE

Made in Canada by
The C. TURNBULL Co.
OF GALT LIMITED

game fish. It is pointed out that the sale is prohibited in Ontario and that the markets in New York State are not supplied by angling alone. This seems to be particularly a case in which the laws on both sides of the river should be uniform if full and effective protection is to be given to the fish. The bulk of the friends of protection in New York State see this point and will, we are convinced, work in the interests of the promotion of harmony in the existing laws on both sides of the line. For Ontario to follow New York would be to go back, and therefore we hope to find New York coming up to the level of Ontario before many months have gone by and that to the great benefit of the future of the black bass.

There are lots of anglers, of course, who would not credit the statement that the moon shining on fish spoils them, says a writer in the Omaha World Herald. There are a large number of skilled old fishermen up about Walker, on Leech Lake, in Minnesota, and on being told of this effect of the moon on the fish, when I was up there several years ago, I enquired of old man Busch, the old hotel man and best maskinonge hunter of the region, and he told me that fish exposed to the moonlight were sure to spoil. A number of other old fishermen about the lake told me the same thing. Old man Busch said that the moonshine made the fish soft, and tainted it to such an extent as to be unfit for the table in a few hours.

Every angler knows the trouble experienced with "snagged" hooks. The best fishing is generally obtained where snags abound and the loss of hooks as well as the loss of time in refitting the line, amounts to a considerable item. Anglers will, therefore, be delighted to learn that a "Snagged" Hook Releaser, which does its work effectively without frightening the fish, has been patented and placed upon the market by the Immell Manufacturing Company, Blair, Wis. The device is small, convenient and workable. When the hook is snagged the Releaser is placed upon the line

A Dependable Companion

Wherever you go or whenever you go, whether on business or pleasure, be sure to take along a Conklin Pen, and you'll always be ready for any writing emergency. You'll never be held up through lack of ink. When last drop is exhausted fill

CONKLIN'S Self-Filling Fountain Pen

again at nearest ink-well by simply dipping in pen and pressing Crescent-Filler. No bothersome dropper, no fuss, no muss, no cleaning up to do. Self-filling, self-cleaning. Won't scratch, blot, balk or skip. There is no other pen in the world like it.

Leading dealers handle the Conklin. If yours don't, order direct. Prices, \$3.00, \$4.00, \$5.00 to \$15.00. Send for handsome new catalogue.

THE CONKLIN PEN MFG. CO.
315 Manhattan Bldg.
TOLEDO, OHIO . . . U. S. A.

*Drinks
Ink
Like
A
Camel*



and let go. A little weight on the guide wire acts like the hammer of a pile driver and drives the hook out of the snag. In this simple manner a "snagged" hook is quickly and effectively recovered. The smaller trout and bass size are retailed for 25c and the larger Releaser, which will bring out spoons, spinners, minnows, &c. for 35c. Anglers who have used the Releaser are enthusiastic in its favor, and declare that so far they have succeeded in releasing hooks every time. One gentleman thinks every angler in America should possess one and is sure it would add very materially to the pleasures of their fishing.

Sportsmen who work hard enjoy their pipe and in quiet contemplation live over again the glories of the chase. For thorough enjoyment a good pipe is necessary and the Sanitary pipe meets all requirements. This pipe is bored in such a way as to prevent the nicotine and saliva from coming into contact. The result is that every particle of tobacco is kept perfectly dry and the after effects of

a smoke are delightfully soothing. The pipe cannot become rank, and a cool, clean, dry smoke, without a biting of the tongue, is ensured. To clean the pipe it is only necessary to remove the bowl device and scrape the nicotine bowl with a pen knife or sharp instrument. The saliva may be poured out by simply removing the stem. The cost, which will be repaid in a few weeks by the saving of tobacco, to say nothing of increased comfort and pleasure, is but one dollar postpaid. The Sanitary Pipe Company, 125 Cutler Building, Rochester, N. Y., will supply any number of pipes for the price mentioned.

Wolf stories come in from Fort William. The wolves are said to have been so numerous and bold during the past winter that settlers could not go out with safety unless well armed. A Finnish settlement off the Shuniah Road was the main point infested by the wolves. One man is said to have seen a pack by his wood pile and thinking they were dogs walked quite close to them on his way

from the barn. Discovering his mistake he made the house in record time. Six wolves chased a settler back to town where the man purchased a rifle before again venturing upon the homeward journey. There were many discussions over organizing a wolf hunt on a considerable scale, as with the settlers roused in defence, and the added incentives of the bounty and the pelts, it was believed such a hunt would have been successful.

Fishing specialties abound but as all fishermen who have tried them are aware none are more effective than those known as "U.B." Their excellence in practical working is so great that once tried they are always used. By means of the U. B. Live Frog Harness the fishing with a frog for a bait is not only made pleasant but effective. By means of this harness the frog is held alive without hooking and having the free use of every part of its

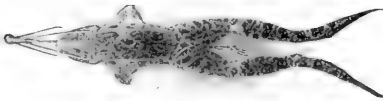

body retains a natural position. Any number of casts can be made without injury to the frog, and it can leap, float and swim with ease. As a spinning bait the U. B. Spin Fly is attractive and effective. Its appearance is life-like and resembling a fly or bug struggling in the water, its alluring features prove irresistible. It is weed proof, with the weed guards appearing as part of the fly. The U. B. Tandem for casting or trolling with live

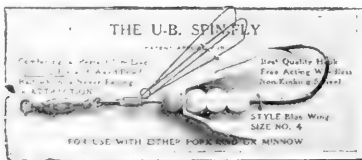

minnow is designed with the view of keeping the minnow alive and prevent its being torn off by casting. Live minnow is always a good bait and the U. B. Tandem is a great bait saver as well as a life-preserver. Then there is the U. B. Weedless Hook. This hook is weed proof and by yielding readily the fish is hooked when a strike is made from any direction. A recognized feature of merit

in the hook is the double ring and the swivel combination which makes it non-kinking, prevents twisting of bait, and adds life-like action by oscillating motion imparted to the minnow or other bait. The U. B. Weedless hook is made of the

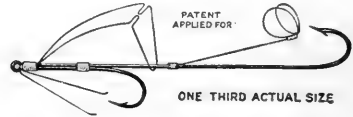

highest grade hollow-point hooks and with weed guards of phosphor bronze absolutely preventing rust. The prices of these specialties range from 15c to 35c and they can be obtained from Unkefer & Bradley, manufacturers, 91 Dearborn St., Chicago.

A correspondent writing from Manitoba in the early part of February states that in his old hunting district he saw but two antlered bulls out of fifty moose, the rest being bulls without horns or old cows. He acted as guide to several parties but though they had no difficulty in getting their game they were all small moose. He did not hear of a decent head being taken and although one man remained the whole season hoping to get a nice head, he failed in his purpose. In his opinion the moose have not yet recovered from their trouble of two years ago, although their skins are now beautifully clean, and the general reports were that they were not as fat as usual. During the winter the snow was very deep and brought down many big game animals from the upper hills, the cold weather being at times as much as 63 degrees below. Trappers reported a restricted fur season and the protected beaver appeared to be the only animal holding its own and increasing in numbers. In one place they dammed the river running through a small town and allowed many people to watch them at their clever engineering feats. As soon as any noise was made the beaver on picket duty struck the water with his tail and in a twinkling all was over for the night. Partridges were plentiful during the fall but weasles did great execution amongst them. Timber wolves were few. Until the rabbits and squirrels return the scarcity of fur is likely to continue.

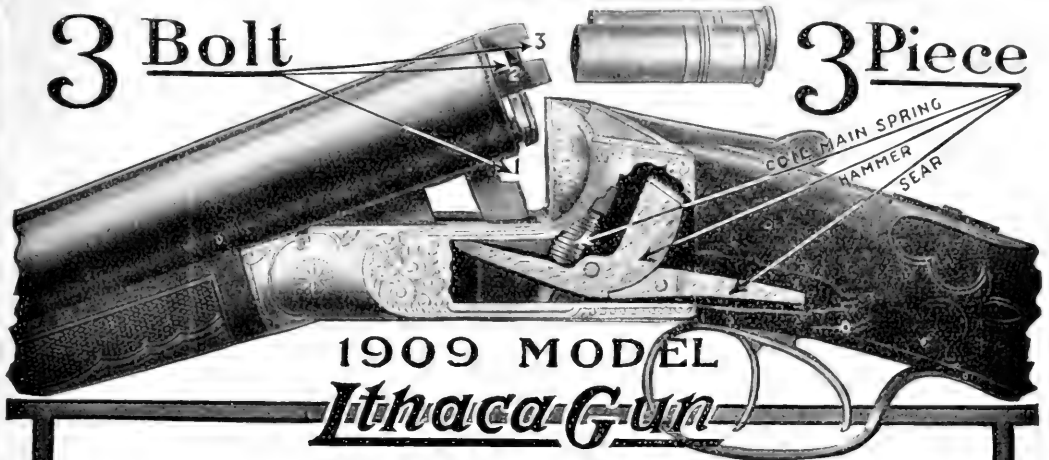

Our new "3 Bolt-3 Piece" 1909 Model gun has the simplest and fastest lock ever put in a gun. Some makers claim a three piece lock but do not show or count the main spring—now we both show and count the main spring—see cut above. Please note we have cut out all cocking bars, levers and push rods and hook right on to the toe of the hammer. This not only makes a lock with large strong parts but a lock that works as smooth as oil. We use an unbreakable coil top lever spring, also a coil main spring, which acts directly on the hammer, and a horizontal sear, which makes a very fast lock with a quick, clean, sharp and snappy pull. The hammer has only a half inch to travel as compared with over an inch travel in other guns, which makes the lock 50 per cent. faster. If you are a trap shooter you will readily see the advantages of this lock—we figure it will increase your score 5 per cent. We make dainty little 20 gauge guns in all grades hammerless. Send for Art Catalog fully describing our 1909 Model gun. Request special prices on our entire line, 18 grades, \$17.75 net to \$300.00 list.

Ithaca Gun Co., Dept. No. 13, Ithaca, N.Y.

Game Inspector Kerr, of Hamilton, prosecuted Albert Wade, of Burlington, for shooting wild duck on Sunday. Wade's excuse was that he shot the bird on Saturday but as the bay was rough he was unable to go after it till Sunday, when he found the bird was only wounded and as the best way of despatching it he fired at it. A fine of five dollars was inflicted.

A well known and favorite rendezvous for sportsmen is the Algoma Hotel, Port Arthur, Ont., and many of our readers, who have at various times enjoyed the comforts to be there obtained, will be interested in knowing that an extensive plan of additions to the premises has recently been carried out. Mr. George Hodder, of Messrs Merrill and Hodder, proprietors of the hotel, was his own architect, and the extensions, which include ten most up-to-date and commodious sample rooms, give evidence of his ability in that line as well as his reliability as a supervisor of extensive work. Sportsmen may not be directly interested in the

new sample rooms, which are complete in every way, but indirectly they are deeply concerned. The increased facilities for business in the commercial trade ensure a continuance of, and improvement upon, the attentions hitherto given them and with increased confidence of securing the best that is possible to provide them, they may visit the Algoma whenever business or pleasure leads them to Port Arthur.

The report of the fisheries branch of the Dominion Marine and Fisheries Department, covering the fiscal year ending with last March, has been presented to Parliament. The report shows that the whole catch of fish by Canadians in Canadian waters totalled for the year twenty-five and a half million dollars. This is a falling off of three quarters of a million, as compared with the preceding year. By Provinces, Nova Scotia leads with a total catch valued at \$7,632,330; British Columbia comes second, with \$6,122,923; New Brunswick third, with \$5,300,564; Quebec fourth, with \$2,047,-

RAW FURS

WANTED IMMEDIATELY

200,000 MUSKRAT

We buy all other kinds of Furs.
Shipments solicited.

The Monteith Strother Fur Co.
11-13 Church St., Toronto, Ont.

390; Ontario fifth, with \$1,935,025; and Prince Edward Island sixth, with \$1,492,695. The output of the salmon fisheries for the year was \$5,014,446; lobsters, \$1,084,122; cod, \$3,619,818; and herring \$2,073,756. The industry employs over 71,000 men. The report urges that the protection and development of the great resources of the waters of the Dominion would be facilitated were the present divided authority and overlapping of federal and provincial jurisdiction united in one central system under definite control.

A report comes from the Old Country to the effect that two poachers were routed out of some private preserves by deer. These men disturbed the animals by night and were so frightened by the attacks made upon them that they preferred to be taken by the keepers rather than stand the attacks of the deer. It is stated that a party of sportsmen were routed by the same animals a few days previously. The deer showing so much boldness are stated to belong to the imported black Japanese variety.

A brush between Government officers and fish poachers on the Niagara river was reported during January. Men in a power launch were seen dynamiting fish on the Canadian side. Chase was given and when the men declined to stop they were fired at with rifles and replied with shot-guns. No one was injured and the men in the launch were successful in getting away. Mr. Tinsley, Chief Superintendent of Fish and Game for Ontario, gave orders for a strict patrol of the river.

For some time dynamiting has been going on, the discharges killing the fish, which comes to the surface, are easily gathered in, and sent to Buffalo and other cities for marketing. The United States officials promised hearty cooperation in any efforts to capture the predatory band.

A grand method of acquainting the people with the wealth of which they are inheritors and custodians has been adopted by the Rev. G. F. Salton, who recently lectured in Hamilton on Algonquin Park and Economics of Forestry. The audience was an excellent one and the Rev. gentlemen made an effective plea for instruction of the young in the great future before the great Dominion, provided the vast forest resources are properly preserved. The result of such education would be the development of study, intelligent, patriotic foresters, the like of which could not be found even in the timber loving country of Germany. In the blood of every Canadian was the call of the wild and the lure of the forest. In the Canadian forests tired and nervous wrecks received strength from the great silent teachers of the woods, —strength that clarified the vision and toned and invigorated jaded nerves.

A wolf supposed to have escaped from the park at Belle Island two years ago has been creating havoc among the sheepfolds of Middlesex county, and it is estimated that sheep worth a thousand dollars have fallen victims to this animal within the last twelve months. Many attempts have been made to put an end to its depredations by encompassing his downfall but up till the beginning of February the wolf escaped every effort for his overthrow. At that time he was seen so closely engaged in a meal that a local marksman got sufficiently close to put in a fatal bullet. The wolf proved a fine specimen, weighing forty two pounds, standing two feet three inches in height, and measuring three feet one inch in length. One township paid out over seven hundred dollars at a two-thirds valuation for sheep destroyed. The farmers and inhabitants generally experienced a great relief on hearing of the death of the animal.

SPORTS AFLOAT

A section devoted to those who brave wind and wave.

The Interlake Races.

For the first time in its history the Interlake Yachting Association will hold its annual regatta in Toledo. The dates named will include the week beginning August 23, or covering the period of Toledo's first annual King Wamba festival. This was decided upon at a meeting of the association. The Toledo Chamber of Commerce offered extra inducements in the way of \$2,500 in cash. Among the prizes to be sailed for in the catboat class will be a costly loving cup presented to the Toledo Yacht Club by President-elect Taft. The association adopted a new set of catboat restrictions as well as the universal rule as amended by the Atlantic coast conference, and ratified by the Yacht Racing Union of the Great Lakes.

The Future of Canada's Cup.

The Toronto Telegram says: The recent mild spell, almost breathed fitting-out time, which reminds us that there is a bare possibility of a Canada's cup race. No one has said the word, but the Rochester Club is now as sore as forty pups at R. C. Y. C., behaving, so the south shore-ites say, like a lot of children sailing toy boats on a creek. Indeed, they would now welcome a challenge from any club and with any specific boat.

So here presents itself an opportunity for some rising young club to step in and gain the prestige the Royal Canadian Yacht club has undoubtedly lost. The Rochester Yacht club is willing to talk business with anyone.

Does it not occur to the Queen city club that the psychological moment has about arrived when they should step in and unfurl their standard to the breeze? W. H. Whitney, a member, is negotiat-

ing for the Cherry Circle, three times winner of the Lipton, and we understand the Rochester people would in no wise be adverse to accepting a challenge for a race with a specific boat mentioned as challenger.

This is the manner in which the race for the cup against Vencedor was pulled off, and why cannot the Queen city club follow the same procedure? In any case it seems a capital chance for some youngster club to make a name for itself, and, by the way, can the Hamilton Yacht club show any good cause why they should not be on the ground with a challenge?

They breed sailormen at that end of the lake, they do, and it's high time the men down at the Beach stirred themselves.

Noiseless Motor Boats.

No more will motor boats disturb landsmen with their exhausts, if a bill which was unanimously reported from the merchant marine and fisheries committee of the United States Congress, becomes a law. This bill would require mufflers on motor boats which do not have exhaust pipes under water.

Waiting For Durnan.

A cablegram from London states that Arnst has promised to go to England to meet Barry this year. He is awaiting a reply from Durnan in respect to the match at Toronto.

Queen City Yacht Club.

At a general meeting of the Queen City Yacht Club, Robert Downard was elected rear-commadore, Harry Osborne, hon. measurer, with Geo. Corneill as as-

Launch Fittings

BRASS AND GALVANIZED IRON

Compasses	Lamps
Flags	Life Preservers
Fenders	Oiled Clothing

John Leckie

Limited

76 Wellington St. West, Toronto

sitant, and the following sailing committee, the last three names representing the motor boat interests: Messrs W. Joseph Hales, Richard M Ewing, Augustus C. Ellis, George P. Beswick, Claude C. Brooks, Louis L Martin, George Cuff and James W. Commeford, jr.

A good report of last summer's sailing and racing was made by the retiring rear-commodore, C. S. Armstrong, and a hearty vote of thanks was given him and his committee for good work in looking after the sailing interests of the club for 1908.

“A Practical Treatise On Marine Gasoline Engines” just published by The Ferro Machine & Foundry Company of Cleveland has filled a long felt need of motor boaters. It is a complete, practical reference book, compiled by experienced motor and boat experts. It tells, with the aid of more than three hundred illustrations, all about the construction, installation and operation of marine engines. Some of the subjects covered are the actual working of gasoline engines,

the carburetor, ignition, cooling, lubrication, offset cylinder, construction and manufacture of motors, reverse gear, reversible propeller, marine gasoline engines for heavy duty etc. This book may be secured by sending twenty five cents to The Ferro Machine & Foundry Company, Cleveland, Ohio, and mentioning Rod and Gun.

Motor Ice Boat

A motor ice boat has just been built by Jacob Cornwell, jr., and Wilber Wenck, two boys of Red Bank, N. J., and although it is a crude affair it has had several successful trial trips on the Shrewsbury River, and has demonstrated that a motor ice boat is practical. They are now making arrangements to build a larger boat.

This little ice craft is six feet long, and has a three horse-power motor set upright in the boat, which is propelled by a chain drive revolving a spiked log of wood eight inches in diameter, and about a foot in length.

The steering runner of the boat is in front instead of behind, and the steering apparatus is controlled by a lever instead of a tiller.

Patented X Cell Battery Boxes

The new patented X cell battery boxes consist of a strongly made and neatly finished hardwood box with partitions just large enough to allow the cells to slip in. Contacts are provided in the box so as to connect properly the carbon and zinc electrodes and all that is required is to remove the cartons from the cells, put the cells into the box, close the cover and connect the wires from the strong check nuts outside the box to the spark coil. The boxes are made to hold four, six, eight or twelve dry cells of standard size and are connected either in series multiples, or in multiple series, as desired. On the the boxes for eight cells or more a switch is provided. The user of dry cells will find in these new boxes relief from his numerous troubles and losses. Amongst the advantages gained may be mentioned: The connections having proper resistance do not run down the battery the connections always being clean and bright ensues efficiency;

the connections being absolutely correct means the avoidance of loss in trouble and money; as the connections make wire crossing impossible there is no need to get stuck; as the batteries are protected against grease and moisture their life is doubled; as the batteries do not vibrate their life is trebled. This means the biggest saving on batteries for the work in the box under proper conditions. The four cell box is \$3, six cell \$4, eight cell \$5 and twelve cell \$7. The holders of the patent are the manufacturers, the Electrical Specialties, Limited, Toronto, and the boxes can be obtained through all automobile and motor boat dealers.

Fine Launches on Canadian Waters

The firm of M. L. Butler, Brighton, Ont., are building some very fine launches of the following sizes:

18ft. by 4ft. 9ins. with 2½ to 3½ H.P. motor installed, seating capacity 10 to 12, speed 8 miles an hour.

23ft. by 5ft. semi-speed model with 5 to 7 H.P. motor installed, seating capacity 12 to 14, speed 10 to 11 miles an hour.

The 18 ft. launch is a strong, well built, handsomely finished boat designed for use around summer camps, and is a splendid sea boat, a good carrier and remarkably steady for a boat of this size.

The 23ft. launch is a boat designed for those who want a comfortable launch, that is at the same time speedy, steady, seaworthy, and an exceedingly graceful and handsome boat in design and finish.

These launches are sold with engines installed or without at the option of purchasers, at prices that are very reasonable.

They will design and build any special type to order or from plans submitted, and will be pleased to furnish further particulars and photos upon request.

International Regattas on the Pacific Coast

The Pacific International Power Boat Association, of which Mr. R. P. McLennan, of Vancouver, is President has formulated a big program, and assumed

The Clarendon Hotel

PORTAGE AVENUE

WINNIPEG, MANITOBA

Headquarters for Commercial Travellers, Sportsmen and Tourists. Good comfortable rooms and excellent cuisine. Free Bus meets all trains.

AMERICAN PLAN

Rates \$2.00 per day and up

C. Y. GREGORY, - Proprietor

jurisdiction over territory from Nome to Mexico.

Hitherto the association, although practically the head of organized motor boating on the Pacific coast, has been limited to the north west in scope. However, Secretary F. M. Foulser, who has just returned from a trip to California, reports that the Oregon and California motor boat clubs are desirous that the Pacific international name be extended to include the southern as well as the northern coast. Accordingly, the members have voted unanimously to accept after consideration, clubs and individuals eligible to membership from Grays Harbour on down the coast line to San Diego. Secretary Foulser stated that speed boats from the entire coast would assemble to race in Seattle during the Alaska-Yukon-Pacific Exposition.

The association has elected a new commodore, Vince H. Faben, to succeed Reginald H. Parsons, who has resigned because he will be out of the city for the greater part of the time during the coming season. Both the old and the new commodores are actively identified with motor boat racing in the northwest. Miller Freeman was named as a delegate to a meeting to be held shortly in New York of representatives of power boat clubs from the whole country, when a national organization will be formed.

THE HILDEBRANDT SPINNERS



are spinners that spin; no swivels required. Suitable for all kinds of fishing. Made in 9 different sizes and 50 styles of pearl, polished brass, and brass spoon blades, nickel, copper, and gold plated. In fancy feather and squirrel, fox and buck tail flies. Send for catalogue.

The John J. Hildebrandt Co., Drawer No. 8, Logansport, Ind.

AUTOMOBILES AND AUTOMOBILING



Taxicabs for Toronto

Taxicabs will be running in Toronto by March first. This was the statement of the representative of the Berna Motor and Taxicab Company, Limited, who are introducing the new vehicle. The police commissioners of the city have been requested to so amend their by-laws as to admit taxicabs under their regulations.

The rate to be charged is somewhat different to that now existing with the horse cabs. For four persons twenty cents will be charged for the first half-mile, and ten cents for each additional half-mile. There will be no charge for the time the taxicab takes to go from its station to the place where it is called, or back after the trip is over. But for every four minutes the taxicab is kept waiting a charge of ten cents will be made. Twenty cents will be charged for conveying trunks, but hand bags will be carried free. The new company will put uniformed men on their cabs.

No Auto for Toronto's Fire Chief

The Board of Control for the City of Toronto turned down a recommendation to provide an automobile for the use of Fire Chief Thompson, the recommendation for such a provision being based upon increased efficiency of the chief's services through better means of inspection and more promptness in being present at out-breaks of fire.

"Chief Thompson is the first man the firemen look to for direction at a big fire, and it is of essential importance that the chief be the first one on the spot to size up the situation, so that no time or effort be lost," said H. H. Love of Hyslop Bros., emphasizing the necessity of the course the Board of Control declined to take.

Mr. Love stated that automobiles had been an unqualified success in what ever fire department they had been introduced, and the city of Vancouver had recently

purchased a Cadillac car for the use of their fire chief.

M. A. Kennedy, general manager of the Dominion Automobile Company, expressed surprise at the action of the controllers in striking out the appropriation.

"No city the size of Toronto," said Mr. Kennedy, "can afford to be without an automobile for its fire chief. The saving of time and the increased facilities would more than compensate for the initial cost. The maintenance would cost very little. All the cities of any size in the United States have them."

Other automobile agents in Toronto also endorsed these views.

Shelby Seamless Steel Tubes

The National Tube Company of Pittsburgh, Pa. have issued a handsome booklet giving a history of the efforts to manufacture seamless tubes and describing, by means of letter press and illustrations, the methods adopted by them in the process of manufacturing Shelby Cold Drawn Seamless Steel Tubes.

Although the industry has now reached vast proportions in the States it is but a decade and a half since Seamless Tubing was not put through all processes in that country. Up to that time the billets from which the tubes were being drawn cold for bicycle purposes were all prepared and partly finished in England and Sweden. Brass and copper were tried but proved too costly for commercial purposes, while lead lacked the strength demanded for many of the uses for which tubes are desired.

The historical review of the industry covers one hundred years. The making of gun barrels was the use to which the earliest products were put and in the infancy of the gas industry they were employed for conducting gas. Later on various efforts at improvements were made and when bicycles became popular

High Grade English Tackle

Write for CUMMINS Catalogue of Fine

FISHING TACKLE

(Special Canadian and American Edition)

SENT FREE TO ANY ANGLER

W. J. Cummins has Supplied Tackle
to Canadian Anglers for over 40 Years

W. J. CUMMINS

FISHING TACKLE MAKER

(DEPARTMENT "W")

BISHOP AUCKLAND, ENGLAND

the industry made great progress. In England the first attempt at seamless tubes was made in 1837 and improvements were patented in 1867 and 1882.

Seamless Steel Tubes not only at a low price but in large quantities were demanded when the bicycle craze reached its height several years ago and the much sought for method of piercing was finally developed by Mr. R. C. Stiefel and put into service as the Stiefel Piercing Machine. "Both quests—for a machine to work and a steel to be worked — were practically satisfied at the same time and Seamless Steel Tubes then began to count as a respectable branch of the great Steel Industry in America." The application of Shelby Seamless Tubes to marine and naval boilers gave a substantial impetus to the business and directed it along new lines ; and when the leading railroads began to specify Shelby Tubes for their locomotives their success and future were finally assured. We are told that while neither steel nor tubes are perfect constant study and experiments are leading to closer approximation "to absolute

perfection as an end not ever to be wholly attained, but always kept as an ideal."

The various stages through which the steel progresses are fully described, the explanations being rendered more clear by the fine illustrations. Although the operation of cold drawing is simple in principle and not new the best methods are followed with the Shelby Seamless Tubes with the result that the uses to which the Tubes are now put are thousands in numbers and are increasing in variety every day. Some of these processes are severe and the steel is strengthened in such a manner that the tubes can be put to uses never imagined only a short time ago. "Many of its applications are simple and direct but in countless other instances it is merely the basis of more complex structures. Yet we are just at the beginning of the story of its possible uses. In hundreds of machine shops and factories Shelby Seamless Tubing is unknown and in hundreds of others it is still untried and untested. This is true because its life as a commodity has extended over a period of but a few years.



From the inlet-tube of a catsup-bottle-filler to the bushings on the cross-head of a hundred ton express engine is a long stretch, but Shelby Seamless Steel Tubing covers the interval." The booklet is believed to be the most complete description of the modern method of making seamless steel tubing yet issued. The Company are not offering the booklet for general distribution but will be glad to supply a copy to these whose position indicates a legitimate use for the same.

New Canadian Motor Company

A charter has been granted to the Brintnell Motor Car Company, Limited, of Toronto. The new Company is to have a capital of \$60,000 divided into six hundred shares of one hundred dollars each and the first directors are William Joseph Fletcher, merchant; Reginald Radcliffe Perry, Errell Chester Ironside, and Allan Travers Lewis, law students, and Harry Reilly, accountant, all of Toronto. The work of the Company as described in their memorandum of agreement is "to

carry on the business of manufacturers of, dealers in, letters to hire, repairers, cleaners, storers, and warehousemen of automobiles, motor cars, motors, cycles, bicycles, velocipedes and carriages, and vehicles of all kinds, whether moved by mechanical power or not, and all machinery, implements, utensils, appliances, apparatus, lubricants, cements, solutions, enamels and all things capable of being used therewith, or in the manufacture maintenance and working thereof respectively."

Carload of 1909 Russels

A notable shipment of new automobiles has just left Toronto for Winnipeg by express.

It was made by the Canada Cycle & Motor Company, and consists of a full line of the 1909 Russell models.

The shipment includes the company's luxurious fifty-horsepower model "K," the thirty-horsepower model "H," the twenty-four-horsepower model "L," a very handsome cab and the various other cars of the 1909 line.

Many of the cars are for immediate delivery to customers.

The shipment will arrive in time to be used for a special exhibition at the bonspiel, Winnipeg's great curling event, where those who visit the city from all over western Canada will have an opportunity to see what Canada has achieved in automobile building.

The automobilist finds he wants many things to obtain the maximum of pleasure from his purchase. None of them will do him better service than the "L and M" Tire Shoe Lifter—a simple, cheap, and effective tool which enables the owner of an auto to insert or remove the inner tube and lugs whenever necessary with ease. The "L. & M." Tire Shoe Loosener will loosen rusted or frozen tires all the way round and is equally useful for any kind of tire or rim. A mechanical sponge made of mop yarn and known as the "L. & M." Perfect Auto and Carriage Washer is made by the same firm. This washer will, it is stated, outwear six sponges and will wash between spokes and under fenders. The Canadian distributing agent for these useful and effective inven-

tions of overwhelming importance to every automobilist, is George B. Frost of Smith's Falls, Ont. Mr. Frost is also agent for "The Little Steersman," an effective steering and safety device for automobiles and most favorably known to all who have adopted it.

Autos in Prince Edward Island

In the supreme court at Charlottetown, P. E. I., on January 29 last, arguments were heard in the famous automobile case. Last year the Provincial legislature passed an act prohibiting the running of autos. To make a test case the owners ran a machine last summer and were promptly fined \$500. They applied for certiorari to quash this conviction, hence the present case. The main contention of the defendants' counsel was that the

running of automobiles upon the public highway constituted what is known as a common nuisance which is a criminal and indictable offence at common law, and therefore any legislation dealing with the subject could only be passed by the federal parliament which has exclusive jurisdiction over crimes.

On the part of the Crown it was argued that the statute in question was in reality a regulation of the public highways, that it dealt with a matter purely local and private in the Province clearly within the scope of Provincial legislative power, that the running of an automobile upon the public road was not in itself a criminal nuisance. The statute did not create any criminal offence. Its effect might be to prevent a nuisance.

Judgement was reserved.



A BOULEVARD PARADE.

Snapshot taken on Queen's Park Avenue, Toronto. Mr. D. H. Hulbert in his four-cylinder Oldsmobile.

The Oldsmobile for 1909.

The new models of the Oldsmobile are now on view at the various agencies of the Company, and a special show of them is being made this month at the Toronto Salesrooms, 80 King St. East.

Our illustration shows the model "D" Palace Touring Car which, at \$3000.00, will doubtless prove one of the most popular cars in Canada this year. It has a seating capacity of five, and in color may be ordered in either Maroon or Brewster Green. Wheel base is 112 inches. and the tread 56 1/2 ins. Of 40 horse power

is meant the ability to stand bad roads and rough weather, and the certainty with which it can be depended upon to answer all demands that may be made upon it in the way of long and hard runs. In other words, the Oldsmobile is not merely an admirable piece of mechanical construction, it is a car which can boast a record that proves beyond the shadow of a doubt, its right to special distinction as an automobile of the kind that gives day-in-and-day-out satisfaction.

Special emphasis is given this fact by



and four cylinders, with a cellullarradiator, water capacity of four gallons, and gasoline capacity of eighteen gallons, this car is the ideal machine for all-round road and touring purposes. It is fully equipped with eight inch head light, generator, oil side lamps, full set of tools, coat rail, trunk rack, etc.

The Oldsmobile has of late been steadily gaining in popularity, and is now looked upon as one of the most important factors in the automobile world. Its makers base their claims as to the superiority of the Oldsmobile, largely upon its exceptional "roadability"—by which

the exceptional confidence placed in the Oldsmobile by the manufacturers themselves, who are so thoroughly enthusiastic on this point as to offer a special agreement to every man who buys an Oldsmobile, whereby the manufacturers offer to keep it in perfect running order for one year at the nominal cost of \$1.00 per week.

Our readers are advised to take advantage of the first opportunity to drop in at the Show Rooms of the Oldsmobile Co., and inspect the various types of this high-grade car that are now being shown.

Motor Maxims

Much coin, much car.
Better rust than bust.
All's well that ends smell.
Money makes the auto go.
One good turn-over deserves another.

An auto in hand is worth two in the ditch.

There's many a slip 'twix the tyre and the ground.

The early policeman catches the unwary speeder.

IT WOULD BE WELL TO TRY

1909

“NEW SCHULTZE”

AND

“NEW E. C. (IMPROVED)”

Smokeless Shotgun Powders

THE OLD-TIME FAVORITES

Stable—Hard Grain—Absence of Recoil

Absolutely Smokeless—Clean Burning—No Blowback

Low Pressures — High Velocity — Wonderful Patterns

POWDERS FOR THE MOST CRITICAL

E. I. DU PONT DE NEMOURS POWDER COMPANY

Established 1802

Wilmington, Del.

S H O T

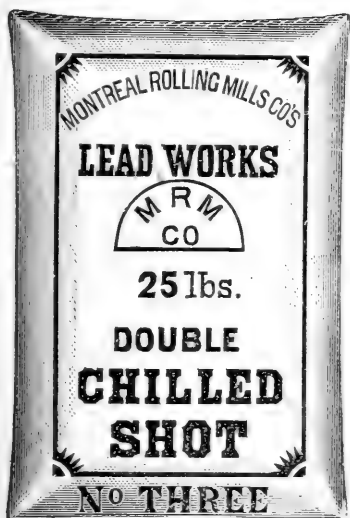

Specify "M.R.M." when ordering

GOLD MEDAL



AWARDED TO

JOHN LABATT

FOR

Ale and Porter

At St. Louis Exhibition, 1904

Only Gold Medal for Ale in Canada

“Among the Players.”

BY THE “PNEUMATIC CRITICS.”

VIA WIRELESS.

Oh, come in my Thomas Flyer,
I do not care to stay,
‘The Devil’ take the vapid joys
That lurk along Broadway.

‘The Crisis’ long is over,
And ‘Girls’ are on the wane,
‘The fighting Hope’ is full of dope,
‘The question’ calls in vain.

‘The Yankee Prince’ is a frightful quince,
The ‘Witching Hour’ draws near
When ‘Little Nemo’ tells the tale
Of ‘Mr. Crew’s Career.’

When ‘Lady Frederick’ heard the news
‘What Every Woman Knows,’
‘Miss Innocence’ fell off the fence
And badly tore her clothes.

Then ‘Fluffy Ruffles’ passing by
Observed ‘The Man From Home’
The famous ‘Music Master’
From the gorgeous ‘Hippodrome.’

Oh ! ho ! he cried, ‘The Great Divide’
‘The Squaw Man’, faltered she ;
He was—“The Thief”—who made my friend
‘Salome’ climb a tree.

Get busy ‘Samson,’ ‘Kassa’ cried,
You ‘Grand Old Army Man,’
The ‘Wolf’ upon a hill I see ;
Oh save me if you can.

He carried her to the ‘Moulin Rouge’
‘The Round Up’ there was gay,
‘The Warrens of Virginia’ said
It was ‘The Only Way.’

And not a kiss to pay for this,
Then I have lost my pull,
‘The Girl Behind the Counter’ said
“Nay, Nay, “You’re Paid in Full.”

The Making of Automobiles

Some sixty or seventy students from the third and fourth years of the faculty of applied science and engineering of the University of Toronto, accompanied by Professor Angus and other members of the science staff, have paid a visit to the works of the Canada Cycle and Motor Company, at West Toronto. At the works they were received by the General-Manager, Mr. Russell, and were then divided into small groups, each of which was placed in charge of a member of the company's staff. They were then conducted over the entire plant, and the various points of interest in connection with each process were carefully explained by the persons in charge of the various parties.

The students were thus enabled to follow intelligently the manufacture of the automobile from start to finish, the principles of operation of the complete machine being also briefly explained and illustrated. Sometime was also spent in the part of the works devoted to the



Quite a few Canadian Anglers have ordered the

"MANSFIELD" FLY BOOK

and many more would do so, if they knew what a handy, compact, and practical book it is. It is more convenient and serviceable than any book on the market. Fits the pocket better, size 6x3½x1. Book has 12 pockets, holding 1 dozen Flies each. Pocket for Leaders

Made of Calf Skin, sells for \$2.50. Alligator, \$3.50.

will be mailed on receipt of price.

Once used all others go on the shelf.

An experienced angler says—"The book, to my mind, is the most convenient form I have ever seen."

Carlos G. Young, Manufacturer
320 Market St., San Francisco, Cal.

manufacture of bicycles. The students returned to the city about six o'clock, after having spent a pleasant and profitable afternoon, for which thanks are to be tendered to Mr. Russell and the other members of the staff of the Canada Cycle & Motor Company, who did so much to make the visit useful as well as entertaining.



An Every Day Scene at the Corner of King and Yonge Sts., Toronto, Ont.



NEW RUSSELL LANDAULETTE.

The Russell Car for 1909 brought out by the Canada Cycle and Motor Company in front of the Parliament Buildings, Toronto.



A Lakefield Canoe On the Zambesi River

This was the first canoe on the Zambesi River and was envied by all the residents and visitors there.

Write for catalogue to

**The Lakefield Canoe
Building and Manufacturing Co.**
LAKEFIELD, ONT.

A Matchless Cigar Lighter

Will be sent FREE to anyone sending us One Subscription to Rod and Gun and Motor Sports in Canada. Address,

W. J. TAYLOR, publisher, Woodstock, Ont.

== USE ==

ENGLISH SCHULTZE

**The Quickest and Cheapest Bulk Smokeless
Powder on the Market**

The last shell loaded from a canister of ENGLISH SCHULTZE contains as perfect hardened grains as the first shell loaded ; no dust at the bottom to give you a shell that "seems to drag" and so spoil your run.



Mr. F. Hooey, shooting at the Parkdale Gun Club on Feb. 13, 1909, won the gold medal presented by Mr. Henry Butt, of England, with a score of 37x40.

Mr. Hooey uses ENGLISH SCHULTZE. Why not get into line?

AGENTS FOR CANADA:

The London & Toronto Trading Co.

14 FRONT ST. E., TORONTO, ONT.

CANADIAN PACIFIC RAILWAY

Canoeing—Fishing—Prospecting

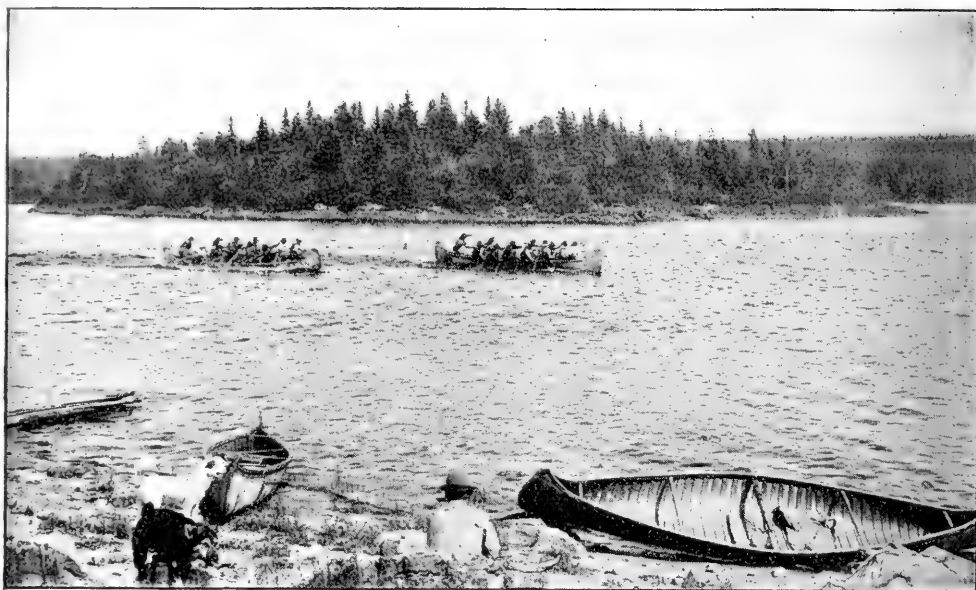

Why not combine some prospecting, or possibly investing, with your trip this year? The following canoe routes, running through a good fishing and mineral country all the way, are the best whereby to reach the silver country, i.e., both ends and the middle of the Montreal River Valley.

- (1) Leave C.P.R. at Temiskaming Station. Steamer up Lake. Canoe via Montreal River to Elk Lake, Gowganda, etc. Also to Quebec side.
- (2) Leave C.P.R. at Markstay, Wahnapietei or Sudbury Stations. Waggon road to Wahnapietei Lake. Thence canoe via Stull's Branch to Smooth Water Lake, Gowganda, etc.
- (3) Leave C.P.R. at Bannerman Siding. Fine canoe trip via Onaping and Deschesne Lakes into the country at head of Montreal River.
- (4) Leave C.P.R. at Metagama Station. This is possibly the best route into the Silver Country via the Hudson Bay Post at Mattagami.
- (5) Another good route is from Biscotasing.

The easiest round trip is to go in at Metagama and come down the Montreal River. All good canoe trips.

CANADIAN PACIFIC RAILWAY

Summer Homes and Sojourns



Our Toronto-Sudbury Line has made as accessible as almost any region in Canada, the famous 30,000 islands of the Georgian Bay with their wildness, bracing air, and freedom from mosquitoes. An island, two or three acres in extent, is an estate, almost a kingdom. A launch is much better than any carriage and a canoe better than a saddle horse. We specially recommend the Bayfield Channel between Parry Sound and Point au Baril for its bass fishing, natural beauty and wonderful supply of islands.

Bass—Trout—Maskinonge

Write us which you want and when you can get away. Let us tell you where to go, where to outfit and obtain reliable guides. Consulting us may prevent unsuccessful trips.

L. O. ARMSTRONG

C.P.R. Offices, Montreal.

TOURIST AGENT.

The Hawser that Tows no Trouble

is the

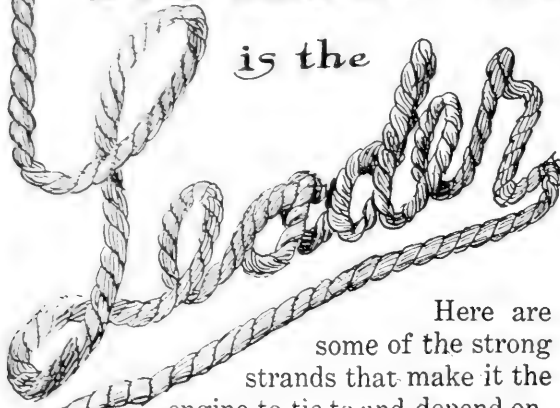

Here are some of the strong strands that make it the engine to tie to and depend on.

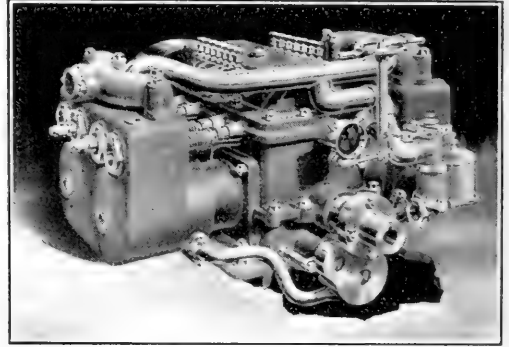

Non-Vibration Possible only through reciprocity of motion and perfect balance, and obtainable in no type of engine other than the horizontal opposed. Don't take, on faith, the assertions of the vertical engine man who tells you that vibration can be eliminated by counter balancing bobs; figure it out for yourself.

Low Center of Weight Leader weight is placed practically at the water line where it acts as ballast, steadying your boat in a sea way. Vertical engine weight, being elevated, has the opposite effect—increasing crankiness, in many cases making a light, narrow boat positively unsafe in a heavy sea.

Accessibility By simply removing the top plate from the crank case of a LEADER every working part is bared to the eye and hand. You can see what ought to be done and do it without skinning your knees and knuckles, greasing your cuffs and ruffling your temper.

Compactness The LEADER engine is the personification of concentrated power. When installed under a cross seat in an open launch, beneath the cock-pit floor of a cabin cruiser or under the deck of an auxiliary yacht it does not take up an inch of usable space, and it keeps your boat spotless and free from odor.

Economy Fuel and repair bills are minimized by the LEADER. A gasoline consumption of not more than one-tenth gallon per brake horse power per hour explains the first item. Master workmanship—selected material and constant attention to detail—the second.

Durability Proven by years of hard service and insured by years of scientific study and engine building experience on the part of its makers, who have always kept the fact in mind that the LEADER is not intended for one year's service but for many years of continuous work.

Our Catalog will tell you more. We want to send it to prospective buyers. This coupon pinned to your letter head will bring it by return mail.

Sintz-Wallin Co., Grand Rapids, Mich.

Please send
the Catalog of
Leader Engines to

THE TRAP

Rod and Gun and Motor Sports in Canada is the Official Organ of the Dominion of Canada Trap-Shooting Association. All communications should be addressed to W. A. Smith, Editor "The Trap" Kingsville, Ont.

Tournament Dates

- April 8—Exeter, Ont., Gun Club, W. Johns, Secretary.
 April 9 and 10—Parkdale Gun Club, Toronto.
 May 6 and 7—Ridgetown, Ont., Gun Club, C. H. Eastlake, secretary-treasurer.
 June 30, 32 and July 1 and 2—Joint tournament of Canadians and American Indians at Queen's Royal, Niagara-on-the-lake, Ont. Thos. A. Duff, 3 Maynard Ave., Toronto, High Scribe, Canadian Indians.

Stray Pellets

Fred Gilbert, at Kansas City, broke 97 out of 100 targets in a snow storm.

Ballistite powder won the most important event in Europe a short time ago, viz., The Grand Prix at Monte Carlo.

It is reported that the genial Tom A. Marshall, accompanied by the also genial Fred Gilbert, will do a lion hunting stunt in South Africa this summer, a la Teddy Roosevelt.

It is unlikely that the familiar and always welcome figure of John R. Taylor, the Winchester expert, will be seen very often in future at Canadian tournaments. He has been transferred to the Sunny South with headquarters at Atlanta, Ga. "John" is one of the most expert as well as one of the most popular exponents of the scatter gun in the professional class and we are all sorry to lose him.

A meeting of Ingersoll Gun Club was held at the Mansion House in that town on Jan. 28rd when Mr. W. J. Kirbyson was presented with the DuPont Trophy won by him in the series of club shoots, and, also, the Elliott Cup. The scores for the DuPont Trophy were as follows. Total 200 targets: W. J. Kirbyson 184, H. W. Partlo 164, Geo. Nichols 162, F. W. Staples 161. Several others entered but dropped out before the finish of the race.

We publish this month a cut of D. Konkle, the energetic secretary of the Beamsville (Ont.) Gun Club. Mr. Konkle has only been shooting at the traps since the winter of 1905, when Beamsville Club was organized. He has already made some very creditable scores. On Thanksgiving Day of that year he won the first prize at Jordan tournament, a Marble axe, which he prizes very highly. In June 1906 he won the Newman trophy, emblematic of the Niagara District championship, with 46 out of 100. On July 1st, 1906, at St. Catharines, he made a run of 65 straight, breaking 96 out of 100. Only recently he won the Du Pont Trophy for the highest average in a series of club shoots.

Beamsville Gun Club

The following were the scores made by the Beamsville Gun Club on Febl 27th, 1909. Conditions—Wind very light, distance 16 yards; trap, Bowrons, known angle; birds, 50 yards



D. KONKLE.

Winner of the Du Pont Trophy, Beamsville, Ont.

This shoot was for a trophy donated by the Club secretary and was a 25 bird race with added bird handicap. Winner used English Schultze. Scores:—

	S. A.	B.
G. S. Karr.....	25	21
Wicksteed	30	17
Battersby	30	16
H. Vidal	29	17
E. Konkle.....	25	18
J. Zimmerman	25	16
W. Lucy	25	17
D. Konkle.....	25	20
Montgomery	33	24



SOME ACTIVE MEMBERS OF HARROW (ONT.) GUN CLUB. (LEFT TO RIGHT) C H. LLOYD, N. BALLARD, A. CUNNINGHAM, C. J. PASTORIOUS, AND E. MCLEAN.

Kingsville-Harrow Shoot

The Kingsville and Harrow Gun Clubs had a team match, 12 men each team at Kingsville on Feb. 4th, when the Kingsville team won with a total score of 201 to 153. No ex-



KINGSVILLE-HARROW TEAM SHOOT—GETTING READY.

ceptional scores were made on either side. The rocks were fast and the light not too good. The weather, however, was delightfully mild.



KINGSVILLE-HARROW TEAM SHOOT—IN FULL SWING.

and the shoot was a very enjoyable one. After the match the visitors were entertained at an ayster supper and this was followed by an evening of speeches in which the protection of big and small game and best open season for each came in for much discussion. Jack Miner, the celebrated big game hunter, was there and being in a reminiscent mood gave some serious and many humorous accounts of his experiences in the field.

These inter-club matches are one of the most delightful features of trap shooting and appeal to many who would not otherwise stay in the game. The following are the scores:—

Twenty-five birds per man:—

Harrow Team—C. I. Pastorius 15, O. M. Pastorius 14, E. D. D. Ford 6, Roy Buchanan 9, Harry Pigeon 15, A. C. Cunningham 18, Godfrey Pigeon 14, Geo. Young 7, Chas. Pigeon 18, Frank Pigeon 18, C. H. Lloyd 9, N. Ballard 10. Total 153. Average 51 per cent.

Kingsville—W. Duggan 17, Dr. Jenner 12, Dr. McKenzie 15, A. Baltzer 19, N. C. Wigle 16, W. A. Smith 19, Gordon Wigle 14, Byron Wigle 18, Jack Miner 16, Dorz Wigle 18, T. Pastorius 19, O. Ferguson 18. Total 201. Average 67 per cent.

Dartmouth Doings

The regular monthly shoot of Dartmouth (N.S.) Gun Club was held on their grounds on Wednesday, Feb. 4th. The day was bitter cold, not much above zero. There was no wind, but the bright sun on the snow was very hard on the eyes and very irregular shooting resulted. Scores:—

	10	20	10	20	SA. B.
B. T. Egan	4	12	8	12	60 36
H. Greene	6	14	5	15	60 40
G. McInnes	8	15	6	9	60 38
F. Monahan	2	5	6	12	60 25
H. D. Romans	7	14	9	15	60 45
A. M. Stewart	6	13	7	15	60 41

Handicap event No. 4 resulted in a tie between Greene, Monahan, Romans, Stewart. Romans won out, making a second leg on Thermos Bottle prize. Romans also won the monthly high average badge, with 75 per cent., which is considerably below recent shoots, the last two being 90 and 80 per cent.



A bunch of Canadian Shooters who attended the Hamilton Tournament in January. G. M. Dunk, G. J. Mason, G. L. Vivian, Walter Ewing. Phil Wakefield, Joe Jennings, Ted Marsh, E. H. Houghten, Winnipeg. Phil Wakefield is showing Vivian the Imperial shell with which he made a straight score in the Grand Canadian Handicap. Walter Ewing is mischievously holding another shell over Vivian's head.

Hamilton Happenings

There was a good turn-out at the regular shoot on Saturday, Feb. 8th, of the Hamilton Gun Club. The wind being very high, it was almost impossible to make good scores. The members were shooting for the trophy given by Klein & Binkley, for a series of six regular shoots. Mr. John Hunter made a very creditable score, twenty-one from the 20 yard mark giving him a lead of three birds over his nearest competitor, at this stage of the race. In the spoon shoot, Mr. Hunter also won in A class, Mr. H. Marsh in B class, and Mr. Fred Oliver in C class. The Buffalo Audubon Gun Club members are coming to Hamilton on the 22nd inst., for a friendly shoot, and the members are looking forward for a very pleasant day. Saturday's scores:

T. Upton.....	10	25	50
John Hunter.....	7	21	20
M. E. Fletcher.....	7	21	20
E. Sturt.....	8	21	19
A. D. Bates.....	4	11	13
C. Thomson.....	5	20	15
T. Crooks.....	8	20	20
H. Marsh.....	3	16	15
Dr. Edwards.....	3	14	17
John Bowron.....	4	11	16
J. Borland.....	4	14	13
P. Friend.....	7	19	8
Frank.....	7	8	
	3	12	9

M. Clifford.....	3	16	16
Rich.....	9	17	13
W. Langhorn.....	3	14	11
W. R. Davies.....	8	18	20
F. Oliver.....	4	14	9
F. Watson.....	1	4	3
Dr. Moore.....	1	10	12
Dr. Wilson.....		17	16

Gun Club Formed in Regina

At a meeting of the members of the Fish and Game Protective Association for the Province of Saskatchewan held at Regina early in February it was decided to form a Gun Club and hold a shooting tournament at Regina during the coming summer.

On several occasions gun clubs have been organized in Regina, but interest has fallen off and the Clubs died out. The idea of a gun club in connection with the association and financed therefrom, was favorably considered, and a resolution that a committee composed of the president, vice-president, Dr. Armstrong and Mr. Ancaster should make arrangements for the formation of a gun club, and the holding of a tournament was unanimously passed. The president, Dr. Low, occupied the chair, and those present were Messrs. Willing, Lawson, Bradshaw, Anderson, Bourmaster, Acaster, Corbeau, Whitmore, Dr. Armstrong, Dr. Kemp and secretary Van Valkenburg. The following officers were appointed for the ensuing year:—Hon. president, Lieut.-Governor; hon.-vice-president, Mr. Willing; president, Dr. Low; vice-president, A. E. Whitmore; directors, Messrs. Lawson, Armstrong and Acaster; sec.-treas., W. M. Van Valkenburg.

Boneless Men



BONELESS MEN are all right for canning, but most men are not going to be canned if they can help it. You cannot get good bone or muscle from white flour bread alone or from pastries or starchy vegetables. Feeding children foods that are lacking in phosphates deprives them of the elements that are needed for making sound teeth, bone and brain. The ideal food for growing children is

SHREDDED WHOLE WHEAT

because it contains all the bone-making, muscle-building elements in the whole wheat, made digestible by steam-cooking, shredding and baking.

For that "bilious, bluish feeling" that comes in the Spring, try this for breakfast: Drink a glass of orange juice or grape-fruit. Then heat one or more Shredded Wheat Biscuits in the oven to restore crispness; pour hot milk over them, adding a little cream and a dash of salt. The Biscuit is equally wholesome or nutritious with baked apple, peaches, berries, pineapple or other fruit, fresh or preserved.

Triscuit is the Shredded Wheat wafer, eaten as a toast with butter, cheese or marmalades.

THE ONLY "BREAKFAST CEREAL" MADE IN BISCUIT FORM.

The Canadian Shredded Wheat Co., Limited, Niagara Falls, Ont.

Toronto Office: 49 Wellington St. East

TORONTO DOINGS.

Stanley Gun Club.

The Stanley Gun Club's weekly shoot Saturday, Jan. 30th, was held in a fierce blizzard, with the result that targets were hard to connect with and high scores suffered in consequence. However, a few enthusiasts were on hand and made the following scores:—

	S. A.	B.
Douglas	50	23
Hulme	90	51
Thompson	60	27
Scheibe.....	75	43
Ten Eyck.....	50	33
Buchanan	60	32
Edkins.....	65	29
Martin.....	85	21
Mason	60	32
Massingham	50	24
Sawden	25	9

The regular weekly shoot on Saturday, the sixth of Feb., of the Stanley Gun Club was well patronized by the members and their friends. Owing to the high wind prevailing the scores were not high. The following were targets shot at and broken by those taking part:—

	S. A.	B.
Dunk	140	126
Joseline	125	81
Jennings	100	71
Stephens.....	100	67
Hulme.....	90	51
Edkins.....	85	41
Pearsall.....	80	11
Wakefield	75	45
G. Scheibe	75	30
Vivian	65	45
Bond	65	45
Halford	55	30
Hogarth	55	25
Douglas.....	55	18
Herbert	50	20
Thompson.....	50	20
F. Scheibe	50	18
Ely.....	45	30
Sawden	45	26
Ten Eyck	40	16
Smith	40	7
Martin	35	18
Thomas	35	15
Black.....	35	15
Richardson	25	11
Sparrow.....	25	5

The following were the Stanley Gun Club scores made on Saturday, Feb. 13th:

	S.A.	B.
Vivian	70	53
Hulme.....	70	48
F. Scheibe	70	27
Sparrow	55	22
Black	40	17
Sheppard	35	17
Hogarth	35	17
Pearsall	45	26
Sawden	45	28
W. Black	60	31
Ross.....	50	28
Douglas.....	55	30
Edkins.....	75	43
Stephens	105	77
Harrison	40	21

The regular weekly shoot on Feb. 20th was well patronized by the members and as the day was ideal for shooting some very creditable scores were made. Dunk and Jennings each getting 23 out of 25 targets from the 20-yard mark and Wakefield two straights in two ten-target events. Good averages were also made by Joselin and Ten Eyck, the latter winning the tie in the shoot on from Vivian by a score of 22 to 21 at 20 yards. Fritz, one of the class B. men, also cut loose, and got a ten straight, and 22 out of 25, while some of the other class B men increased their averages considerably. The following are the complete scores:—

	S.A.	B.
Vivian	105	86
Dunk	105	82

Joselin	90	71
Ten Eyck	85	72
G. Scheibe	80	43
Ely.....	70	57
Wakefield	70	57
Douglas	70	36
Hogarth	70	36
F. Scheibe	65	42
Mason	60	39
Card	60	30
Buchanan	55	37
Jennings.....	50	42
Massingham	50	36
Edkins.....	50	35
Halford	50	30
Pearsall	50	25
Fritz.....	45	39
Hulme.....	45	36
Albert.....	45	27
Sawden.....	35	27
Thomas.....	35	20
Richardson	25	19

In the handicap shoot, varying from 16 to 20 yards, for prizes donated by the club, the winners in class A. were—Jennings 23, Joselin 22, Ten Eyck 22, Mason 21, Hulme 21. In class B—Fritz 22, Massingham 22, Halford 19, Richardson 19, Edkins 17.

Parkdale Gun Club

The regular weekly handicap shoot took place on Saturday, February 20th, the first prize being a gold medal presented by Controller J. J. Ward, won by I. N. Devins, second, pewter mug, won by F. A. Parker, third, sterling silver spoon, D. A. McAdam and A. Wolfe tie. The weather was favorable for good shooting and some good scores were made. Scores:—

40 targets—A. Wolfe 37, Parker 38, Godson 36, Pickering 34, Mason 35, B. Orr 29, Devins 40, Hooey 32, McAdam 37, Jones 30.

The regular weekly shoot of this club was held on Saturday, Feb. 27th and brought out a fairly good crowd. The prizes were first, a handsome dressing case, presented by Mr. A. Harvey of Parkdale, won by A. Wolfe. The second and third prizes, a pewter mug, and a sterling silver spoon, were tied for by A. Devins, F. Hooey and G. Woodburn. The ties were settled by lot, as the light would not permit of a shoot off, in which Hooey was left to mourn. A condition in the series of eight matches, which the Club are holding, that no member can win more than one first prize each month, so Wolfe, Devins and Hooey were debarred, the first going to Woodburn, with Wolfe second and Devins third.

Mr. G. M. Dunk, who is always a welcome visitor, was in good form, breaking 88 out of 100 shot at. Scores.

34, Woodburn 34, Godson 33, Gillies 33, Parker 31, Mason 30, Pickering 29, Orr 25.

At 20 targets—Watson 14, Bush 12, Griffiths 11.

Toronto Rod and Gun Club

The officers and executive of the Toronto Rod and Gun Club have been elected as follows:—President, R. G. Blatchley; Vice-President, Dr. W. R. Patton; 2nd vice president, W. R. Skey; treasurer, F. B. Poucher; secretary, F. Summerhays; captain, L. Strother; official referee, W. W. Jeffers; executive committee, R. Tinning, G. W. Meyer, P. J. Thomas, C. C. Mannamara, R. S. VanVlack. The shoots take place every Saturday at 2.30 p.m. on their new grounds at the Toronto Lacrosse and Athletic Club, Rosedale.

At a shoot held by Parkdale Gun Club on Feb. 13th, '09, Mr. F. Hooey, using English Schultze, won the gold medal presented by Mr. Henry Butt of England, with a score of 37 out of 40.

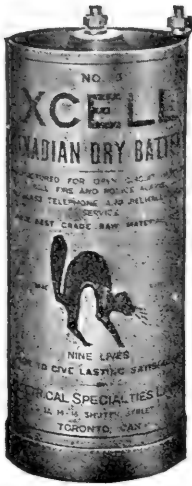

Ignition Troubles Gone AND MONEY IN YOUR POCKETS. WHY?

Using X Cell Ignitors

No. 6, 7 and 8

- For they spark as you want them.
- For they cause sure explosion.
- For they never miss.
- For they always please.
- For they last NINE LIVES.

Using X Cell Battery Boxes

- For proper resistance in wiring.
- For making wire crossing impossible.

- For avoiding detrimental vibration.
- For making good, bright connection.
- For preventing short circuits
- For doubling the efficiency and life of your batteries.
- For a hundred other reasons
- Made in all sizes and for all desired connections.
- For sale by all leading automobile and motor boat supply stores and by



ELECTRICAL SPECIALTIES LIMITED, TORONTO

Petrolea Gun Club Shoot

The following were the scores made by the Petrolea Gun Club, Feb. 4th. Conditions—Wind strong; distance, 17 yards; trap, Bowron. Scores at 25 targets—Dr. Cassidy 20, J. Dale 12, T. Kelly 10, M. Broderick 15, A. Edard 14, C. Egan 3 (latter shot at only 5.).

Only a small number faced the traps on account of most of the members being unable to get away in the afternoon, but as soon as the days lengthen out again the boys will all be out. There was a strong wind blowing across the traps, making the birds erratic and hard shooting, but the scores were not bad at all after a couple of months rest from shooting. The regular weekly shoots will be held in the afternoon on Wednesdays until the days are long enough to shoot after 6 o'clock, when they will be held in the evening.

Cup Contest at Colburg

The first shoot on score for the new cup took place on Tuesday night, Feb. 19th, with quite a number of new members taking part. As there are four more shoots, all those not present on Tuesday will have to shoot the balance on score without any practice night. Shooting begins at 7.30. Those who come first will be able to get away by 8 o'clock. The following are the scores made:

Capt. Ralston 48, Capt. Beattie 45, Capt. Bolster 44, Mr. H. Bolster 43, Mr. Scores 42, Dr. Dulmage 42, Mr. Lund 42, Lieut. Power 41, Mr. Shepherd 39, Mr. Crowther 39, Mr. Morrison 38, Mr. Jaynes 37, Mr. D. McKinnon 36, Mr. C. McGuire 36, Lieut. J. McKinnon 35, Mr. Parker 35, Mr. Orr 33, Mr. Crisgrey 32, Mr. Smith 32, Mr. Hutchings 32, Rev. Ben Oleil 30, Mr. Turpin 28.

Balmy Beach Shoot

The mild weather Saturday afternoon, Feb. 27, brought out a good showing of the members of the Balmy Beach Gun Club at their weekly shoot, and some fair shooting was done. Scores on Watson Cup and club series, 25 targets, handicap: J. G. Shaw 23, Boothe 21, Davis 21, Mason 21, Ross 21, J. A. Shaw 20, Lyonde 19, Pearsall 18, McGraw 17, McDuff 17. Scores at 10 targets—McDuff 9, Craig 8, Boothe 8, Davis 8, Lyonde 7, Mason 6, Cashmore 7.

The official averages of American trapshooters for 1908, which are compiled by The Interstate Association for the Promotion of Trap-shooting, show that Charles G. Spencer, of St. Louis, Mo., leads all other shooters with the unequalled average of 96.77 per cent. for 11,175 targets. Mr. Spencer did this seemingly impossible shooting with a Winchester Repeating Shotgun listing at \$27.00 and Winchester "Leader" and "Repeater" shotgun shells—regular stock loads—the kind a sportsman can buy anywhere by asking for the Red W Brand. Six out of the first nine men used Winchester guns or shells—a showing that tells its own story of winning quality.



Highest award at St. Louis World's Fair. Adopted by governments of U.S., Canada and England. 15 models to select from. Catalogue Free.

ACME FOLDING BOAT CO.,

Miamisburg, Ohio

THE LEADERS OF 1908

Following is a summary of the work of the trap shooters who qualified under Interstate

Association rules during 1908, thus entitling them a rating in the official averages:

The Professional Leaders

Averages for single targets shot from the

	S.A.	B.	P.C.
Spencer, C.G., St. Louis	11,175	10,815	.9877
Heer, W. H., Concordia	9,445	9,181	.9667
Hawkins, J. M., Baltimore	5,945	5,745	.9663
Crosby, W.R., O'Fallon, Ill.	8,390	8,056	.9601
Taylor, J.R., Columbus	11,110	10,056	.9528
Maxwell, G., Hastings, Neb.	11,010	10,480	.9518
O'Brien, E., Florence, Kan.	7,975	7,590	.9517
Barkley, L.R., Chicago	11,590	11,018	.9506
Gilbert F., Spirit Lake, Ia.	10,945	10,402	.9503
German, L.S., Aberdeen, Md.	8,050	7,622	.9468
Ward, Guy, Atlanta, Ga.	8,355	7,860	.9407
Huff, Walter, Macon, Ga.	7,400	6,941	.9379
Heikes, R.O., Dayton, O.	9,025	8,462	.9376
Bills, F.G., Minneapolis	9,400	8,785	.9346
Taylor, H.G., Meckling, S.D.	6,645	6,192	.9318
Hughes, J.M., Milwaukee	8,390	7,808	.9306
Borden H.J., St. Louis	11,190	10,395	.9289
Appar, Neaf, New York	10,835	10,055	.9280
Freeman, H.D., Atlanta	10,235	9,466	.9248
Money, H., Colorado Springs	7,770	7,104	.9220
Young, C. A., Springfield	8,955	8,252	.9214
Barber, R. R., Paulina, Ia.	9,015	8,293	.9199
Stannard, W.D., Chicago	12,000	11,033	.9194
Rogers, F. E., Bucklin, Mo.	6,040	5,551	.9190
Faurote, F.M., Dallas, Tex.	6,945	6,383	.9190
Killam, Art, Granite Cy, Ill.	12,300	11,296	.9183
Wade, L.I., Dallas, Tex.	5,890	5,398	.9164
Fanning, J.S., Jersey City	8,055	7,345	.9118

10-yard mark:-

	S.A.	B.	P.C.
Cadwallader, H., Decatur	8,510	7,752	.9109
LeCompte, C., Eminence, Ky.	6,365	5,777	.9076
Hatcher, A.M., Bristol, Ten.	8,535	7,741	.9069
Glover, Sim., New York	9,210	8,352	.9068
Welles, H.S., New York	8,950	8,100	.9050
Stevens, H.H., Roselle, N.J.	10,060	9,101	.9046
Elliott, J.A., New York	5,905	5,340	.9043
Gottlieb C., Kansas City	10,110	9,139	.9039
Barstow, D.G., St. Louis	6,975	6,304	.9037
Squier, L.J., Pittsburg	9,830	8,865	.9018
Gram, Ed.S., Ingleside	10,495	9,450	.9004
Fitzsimmons, L.H., Chicago	5,315	4,780	.8993
Darton, W.B., Portland, Me.	6,095	5,457	.8953
Plank C.D., Denver, Col.	7,035	6,266	.8906
Marshall, T.A., Chicago	9,315	8,223	.8827
Klein, Rus., Spirit Lae, Ia.	11,420	10,037	.8783
Jackson R.J., Mexia, Tex.	5,865	5,147	.8775
Hoyt, F.W., St. Louis	6,520	5,687	.8722
Adams, C.B., Rockwell Cy, Ia.	5,585	4,868	.8716
McCrea, A.M., Lamar, Mo.	6,650	5,762	.8664
Heikes, H.W., Dayton, O.	9,280	7,975	.8593
Gross, D.D., St. Louis	7,675	6,572	.8562
Lenoir, Fred., Columbus	6,225	5,328	.8559
Clancy, R.W., Chicago	8,235	7,036	.8544
Anthony, J., Charlotte, N.C.	7,830	6,644	.8485
Vietmeyer, H.W., Chicago	12,855	10,755	.8366
Butler, F.E., Newark, N.J.	5,280	4,103	.7770
Lewis, L.R., Atglen, Pa.	6,800	5,191	.7633

The Amateur Leaders

Powers, C.M., Decatur, Ill.	5,690	5,383	.9460
Veach, Wm., Falls City, Neb.	2,505	2,367	.9449
Holland, D. J., Moberly, Mo.	6,485	6,096	.9400
Huntley, S.A., Kansas City	4,775	4,487	.9396
McCarty, G.S., Phil., Pa.	3,180	2,984	.9383
Chingren, E. J., Spokane	2,010	1,884	.9373
Kautzky, Joe, Ft Dodge, Ia.	3,920	3,674	.9372
Day, J.S., Midland, Tex.	2,685	2,511	.9351
Dixon, H., Oronogo, Mo.	6,660	6,180	.9344
Thompson, R., Canonsville, Mo.	2,340	2,177	.9303
Volk, Geo., W.Toledo, O.	4,250	3,946	.9284
Ford, O.N., Central City, Ia.	9,515	8,814	.9263
Fuller, F., Mukwonago, Wis.	3,500	3,239	.9254
Foley, L., Nichols, Ia.	2,620	2,422	.9244
Young, J.S., Chicago	5,185	4,792	.9242
Miller, A. Merna, Neb.	3,245	2,999	.9241
Lewis Barton, Auburn, Ill.	3,685	3,401	.9229
Graham, J.R., Ingleside, Ill.	2,280	2,100	.9210
Atkindon, J.T., Newcastle, Pa.	2,000	1,823	.9200
Auen, E.A., Canarvon, Ia.	2,070	1,903	.9193
Foord, W. M., Wilmington, Del.	3,135	2,882	.9192
Bising, S.W., N.Brighton, Pa.	2,295	2,107	.9180
Townsend, W. D., Omaha, Neb.	2,320	2,129	.9176
Ellett, Fred, Keithsburg, Ill.	5,835	5,399	.9174
Speary, J.M., Marietta, O.	2,040	1,871	.9171
Bray, D. D., Columbus, Wis.	2,545	2,331	.9159
Mulford, W.L., Kirksville, Mo.	2,000	1,831	.9155
Kahler, H.W., Davenport, Ia.	2,635	2,412	.9153
Fowler, H.S., Ballinger, Tex.	2,280	2,087	.9153
Roll, G.J., Blue Island, Ill.	2,300	2,105	.9152
Bower, E.O., Sistersville, W.Va.	3,075	2,811	.9141
Linderman, C.D., Lincoln, Neb.	5,885	5,378	.9138
Asher, V.B., Coon Rap's, Ia.	3,300	3,015	.9136
Maland, J. E., Jewell, Ia.	2,360	2,156	.9135
Hoon, W. S. Jewell, Ia.	5,885	5,099	.9129
Olson, A., Cedar Bluff, Neb.	2,645	2,411	.9115
Bolton, M.C., Viola, Ill.	3,020	2,750	.9106
Dennis, O.C., Welling'n, Mo.	2,065	1,880	.9140
Wetleaf, Wm., Nichols, Ia.	2,520	2,294	.9103
Ditto, C. H., Keithsburg, Ill.	7,020	6,334	.9094
Herrold, D.A., Sunbury, Pa.	5,480	4,983	.9093
Wasser, A.M., Girard, Kan.	2,800	2,546	.9092
Fleming, L.B., Pittsburg	2,075	1,886	.9089
Upson, D.A., Cleveland	4,695	4,267	.9088
Hess, H.I., Nanticoke, Pa.	4,730	4,296	.9082
Vermilya, Fred, Audubon, Ia.	3,060	2,778	.9078
Williams, W.C., Wichita, Kan.	3,335	3,027	.9076

Wescott, C.G., Leesburg, Fla.	3,655	3,314	.9067
Hartman, T.J., Sulphur, Ok.	3,465	3,138	.9056
Dering Guy V., Columbus, Wis.	3,615	3,273	.9053
Mermod A.D., St. Louis	2,775	2,512	.9052
Edwards, F.M., Portsmouth, Ia.	2,445	2,212	.9047
Peterson, John, Randall, Ia.	2,960	2,676	.9040
Wiedebusch, W., Fairmount, Va.	3,595	3,250	.9040
Rober Gus., Manning, Ia.	2,720	2,456	.9029
Thomas, J.S., Pleasant Hill	3,130	2,823	.9019
Stauber, A.J., Streator, Ill.	3,310	2,985	.9018
Ridley Wm, What Cheer, Ia.	3,340	3,010	.9012
Baggerman P., St. Louis	2,790	2,514	.9010
Henline C.D., Bradford, Pa.	3,930	3,539	.9005
Dreyfuss, F.J., Milwaukee	4,560	4,120	.8995
Fisher, Lon, Hebron, O.	9,125	8,193	.8978
Kneussl Max, Ottawa, Ill.	2,620	2,352	.8877
Klay, W.H., St. Louis	2,620	2,351	.8973
Kreger, G.W., Redfield, S.D.	3,055	2,740	.8968
Foltz, F., McClure, O.	3,015	2,704	.8968
Ward, B.D., Aberdeen S.D.	4,105	3,677	.8957
Eaton, Clabe, Fayette, Mo.	2,460	2,203	.8955
Painter, G.E., Allegheny, Pa.	2,725	2,437	.8943
Tucker Geo., Brenham, Tex.	3,090	2,763	.8941
Budd C.W., Des Moines, Ia.	2,700	2,414	.8940
Barto, J.B., Chicago, Ill.	2,475	2,212	.8937
Brown, B.W., Pittsburg, Kan.	2,145	1,916	.8932
Baggerman, W.L., St. Louis	3,710	3,313	.8929
Holzworth, C.C., Prosser, Neb.	3,000	2,675	.8916
Cain Ed, Dayton, O.	3,165	2,820	.8909
Huston Fremont, Perry, O.	4,020	3,578	.8900
Hinshaw, E.C., Okoboji, Ia.	3,820	3,398	.8895
McLachlin, A., New Franklin	3,490	3,104	.8893
Beckwith, A. W., Mt. Pleasant, Ia.	2,100	1,867	.8890
Chamberlin, W.R., Columbus	5,875	5,223	.8890
Ehler Tom., Slater, Mo.	2,695	2,395	.8886
Funk T.H., Littleton, W.Va.	2,560	2,275	.8886
Straughan W., Waveland, Ind.	2,400	2,132	.8883
Noel, J.H., Nashville, Tenn.	4,310	3,855	.8882
Wulf, J.F., Milwaukee	3,600	3,195	.8875
Hansell Geo., Lebanon, Pa.	2,760	2,443	.8869
Veach B.F., Verdon, Neb.	2,465	2,185	.8864
Cooper Bert, Thornville, O.	4,285	3,798	.8863
Kenning, F., Fonda, Ia.	2,120	1,876	.8849
Meaders, Andy, Nashville	2,460	2,176	.8845
Martin, John, Brooklyn	3,765	3,329	.8841
Hurd E.M., Albany, N.Y.	2,905	2,568	.8839
Sergeant, W.G., Joplin, Mo.	2,340	2,068	.8837



GUN CLUBS

Also Curling and Hockey Clubs will advance their own best interests by writing for prices on Medals and Cups.

J. D. Bailey, Ltd.

Yonge St. Arcade, Ground Floor, TORONTO, ONT.

The Sanitary Pipe



Best French Briar—Hard Rubber, Removable Stem. The most scientific and healthful pipe ever made. Separate wells for saliva and nicotine, and a bowl device (see cut) which prevents tobacco from settling in bottom of bowl and becoming soaked or clogged. Cannot possibly become rank like ordinary pipes. THE TOBACCO IS ALWAYS DRY, thus insuring a cool, clean, dry smoke. No biting the tongue.

Price \$1.00 postpaid. Your money back if not perfectly satisfactory. Easily Cleaned. Slip a dollar bill into an envelope now. BOOKLET AND CLUB OFFER ON REQUEST.

Sanitary Pipe Co., 125 Cutler Bldg., Rochester, N. Y.

The Next Time Your Gun Requires Doctoring

THINK OF

ALEX. JOHNSTON

494 Eastern Ave., TORONTO, ONT.

Who has every facility for choke boring, restocking, browning and repairing guns. You can make no mistake in bringing or sending your gun to him.

Peltier, F., Mt. Clemens.....	2400	2120	8882
Fleming, H., Mt. Clemens....	3745	68304	8822
Slocum, F.F., Alcester, S.D.	2860	2523	8821
Flick, J.A., Cleveland, O....	2325	2049	8812
Connor, A.C., Springfield ...	2545	2240	8801
Shoop, Marion, Novinger, Mo.	2000	1759	8795
Moffett, F.W., Jersey City ...	2380	2074	9788
Beard, J.F., Omaha ...	2120	1863	8787
Spencer, W.S., St. Louis ...	2770	2429	8766
Mackie, G.K., Scammon, Kan.	6065	5316	8765
Mallory, jr., L., Bradford...	2085	1827	8742
Stair, J.H., Crookston, Minn	2270	1986	8748
Shell, C.F., Thornville, O....	4665	4073	8730
Alexander, E.R., Tuskegee, Ala	2260	1972	8725
Duis John, Wichita, Kan.....	2060	1786	8712
Alkire, Frank, Williamsport, O	2665	2320	8705
Anderson H.D., Sharonville, O	3200	2784	8700
Fletcher, W.J., Vicksburg, M.	2850	2479	8698
Chadick, E.D., Galveston ...	2050	1782	8692
Carter Geo. L., Lincoln, Neb.	2340	2033	8688
Slusher, J., Lexington, Mo....	2015	1749	8679
Miller, F., Berwyn, Neb ...	2275	1971	8668
Beckwith O., Mt. Pleasant, Ia.	2820	2442	8650
Pleiss B.G., Spokane, Wash...	2010	1789	8651
Talbot, C.E., Audobon, Ia.	3060	2646	8647
Corfield, W.R., Utica, N.Y...	3200	2768	8643
Longshore, A.B., Herndon, Pa	2395	2068	8634
Anderson H., Salina, Kan ...	2050	1768	8624
Ramsey, J.C., Manito, Ill ...	3270	2820	8628
Scofield, Z.E., Cleveland ...	2295	2520	8615
Rogers, E. S., Cleveland, O.	2485	2141	8615
Pumpelly, G. H., Oswego ...	2015	1735	8610
Yocum S. G., Shamokin, Pa...	2850	2453	8607
Smith, H. W., Syracuse, N.Y.	2890	2486	8602
Gibbs, H.D., Union City, Tenn.	3050	2621	8593
Gregory, W.A., Danbury, Conn	2220	1906	8585
Wheeler, Robt., Manlius, N.Y.	2125	1823	8578
Copsey, F. D., Henderson, Neb	2910	2496	8577
Ward, P.C., Walnut Log, T...	3815	3272	8576
Courtney C.A., Sulligent, Ala.	2480	2127	8577
Stout E.M., Circleville, O ...	2165	1855	8569
Greene, J.D., Avon, N.Y ...	2010	1722	8567
Appleman, Joe., Perry, Okla.	2120	1816	8566
Edwards, D., Union City, T.	2500	2141	8564
Warren, J.K., Birmingham ...	2060	1764	8563
Beard Geo A., Evansville, Ind.	2505	2143	8554
Parry T. H., Indianapolis ...	2320	1983	8547
Wilder J.H., Randall, Kan.	2070	1769	8545
Shattuck, Fred., Columbus ...	4145	3526	8506
Milbank, C.R., Kirksville, Mo.	2745	2330	8488
Wilson, H. W., Audubon, Ia.	2000	1697	8485
Abramson, August, Jewell, Ia	2920	2475	8476
Wiseman, J.W., York, Neb...	5200	4399	8459
Wiseman, J.W., York, Neb...	5200	4399	8459
Hendricks, E., Washington, Mo	3040	2571	8457
Long, Clar. A., Lewistown, Pa	2355	1988	8441
Garratt, Ed.C., Seattle, Wash	2205	1861	8439
Wilcox, F.G., Rome, N.Y....	3355	2816	8393
Edgerton, H., Williamatic, O.	2205	1847	8376
Haney, W.M., Nashville, Tenn	2500	2089	8356
Rishel, D. R., Ottawa, Pa...	3850	2792	8334
Fisher, E., Oklahoma City...	2120	1766	8330
Billings C. W., New York ...	2860	2375	8304
Fairhead, J., Jacksonville, F.	2200	1923	8285
Parker, H. R., Cleveland ...	4710	3391	8261
Smith, B.F., Boston, Mass.	2910	2403	8257
Loring, Ray E., Marsilles, Ill	3440	2836	8244
Frantz C., Seneca Falls, N.Y.	2490	2050	8232
Dally, C. J., Baldwinville, Mo	3550	2920	8225
Hoffman, Otto, Harvard, Neb	2220	1824	8216
Miller, Robt., West Allis, Wis	3040	1675	8210
Edwards H., Union City, T.	2000	1441	8205
McIntyre, T., N. Martle, Va	2300	1888	8186
Hook, J.D., Rome, N.Y....	2280	1860	8157
Pollard J.D., Chicago ...	2000	1629	8145
Goodbar J. B., Memphis ...	2300	1865	8108
Mallory S., Parkersburg, W.Va	2945	2387	8105
Gruhn C.F., Columbus, Wis...	2485	2002	8056
Tripp, F.H., Indianapolis ...	2300	1814	7886
Pardee, B., Lock Haven, Pa.	2515	1977	7860
Beckwith E., Mt. Pleasant, Ia.	2560	1994	7789
Mookway, W.R., Syracuse ...	4055	3156	7782
Mathews, Dr. W., Trenton ...	2065	1600	7748
Oreston, H. M., Marion, Ind	2365	1832	7746
Tansey T., Philadelphia, Pa	2005	1538	7645
Haws, W.H., Scotland, Ill...	2770	2104	7595
Wagner, Joe., Utica, N.Y...	2295	1742	7590
Stanberry Hart, Pomeroy, O.	2325	1719	7393
Fulton A. W., Shamokin, Pa.	2335	1715	7344
Dey, J. G.S., Syracuse ...	2785	2024	7267
Davis Geo.N., Macon, Mo ...	2215	1533	7011
Mawhinney, W., Mann'g, W.V.	2160	1405	6504

WATER COLOR SKETCHES

— OF —

Game Birds
Fur-Bearing Animals
Shooting and
Fox-Hunting

Portraits of dogs and horses done
to order from photos

For prices and particulars apply

RICHARD CLAPHAM,
DAVISVILLE, ONT.

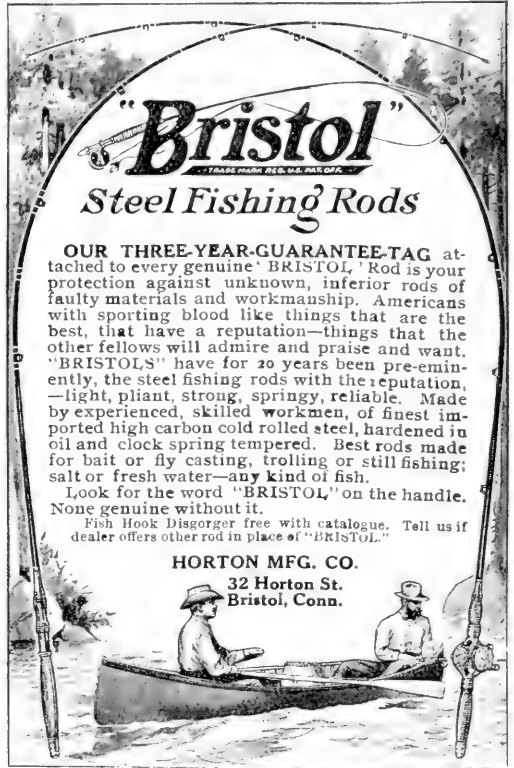

"Bristol"
TRADE MARK REGISTERED
Steel Fishing Rods

OUR THREE-YEAR-GUARANTEED-TAG attached to every genuine 'BRISTOL' Rod is your protection against unknown, inferior rods of faulty materials and workmanship. Americans with sporting blood like things that are the best, that have a reputation—things that the other fellows will admire and praise and want. "BRISTOLS" have for 20 years been pre-eminently, the steel fishing rods with the reputation,—light, pliant, strong, springy, reliable. Made by experienced, skilled workmen, of finest imported high carbon cold rolled steel, hardened in oil and clock spring tempered. Best rods made for bait or fly casting, trolling or still fishing; salt or fresh water—any kind of fish.

Look for the word "BRISTOL" on the handle. None genuine without it.

Fish Hook Disgorger free with catalogue. Tell us if dealer offers other rod in place of "BRISTOL."

HORTON MFG. CO.
32 Horton St.
Bristol, Conn.

THE *Electra Blue* Spark Plug

Guaranteed for

Six Months

Easy to Clean

Made of heavy Brass

fitted with Blue

Porcelain Cap and

Pure Nickel

Electrode



Working equally well
with Magneto and
Batteries

Made with Metric and
Standard Thread.

Price, \$1.75.

With Electra Ebonite
Terminal, **\$2.00**

*Sole Agents for
Canada:*

*Send for Catalogue
No. 3*

The Franco-American Auto Co. 748 St. Catherine St
MONTREAL, QUE.

\$110.00 COMPLETE

4
H
O
R
S
E

P
O
W
E
R

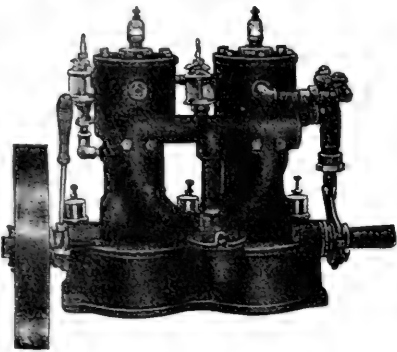

4
H
O
R
S
E

P
O
W
E
R

\$110.00 COMPLETE

One of Our Leaders

This two cylinder, two cycle, three port reversible engine, equally as powerful running either direction, weight 128 lbs., coil for each cylinder. Swings a 16 inch 2 blade propeller 800 to 900 revolutions, depending on the design of your boat. Drives an ordinary 18 to 20 ft. speed boat 10 to 11 miles an hour. One customer writes: "I can cut circles around any of the same model boats as mine that have twice the rated

power." This is a very satisfactory letter to us, but must be more satisfactory to our customer. We would like to furnish you with one of these engines so you or your report would be the same. More power for the weight than any engine made. We have built this same size over 6 years. Send for catalogue of all sizes from 2 to 60 H.P. Very simple; all parts interchangeable. Reliable agents wanted.

Wonder Manufacturing Co.

200 Tallman Street, Syracuse, N.Y.

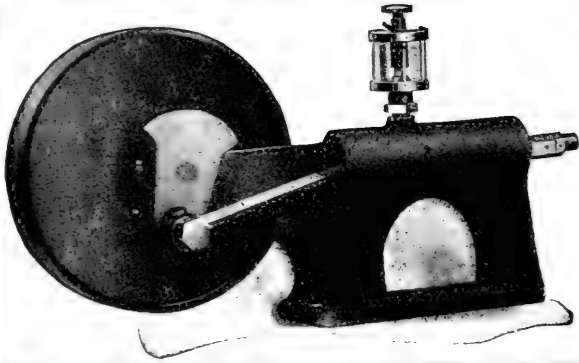

BLOW YOUR WHISTLE WITH PURE-AIR

Meets all Government Requirements
\$7.50. To Canadian Trade \$6.00.

Air Pump has heavy piston fitted with compression ring, the same as a piston in a gasoline engine. 1 1/2 cylinder bore by 2 1/2 stroke. Take advantage of our special Canadian offer and mail us your order to-day. A \$5.00 bill and a \$1.00 bill will reach us if you are not near a money order office.

The Safety Air Pump Co.
322 Jefferson Ave. :: Detroit, Michigan

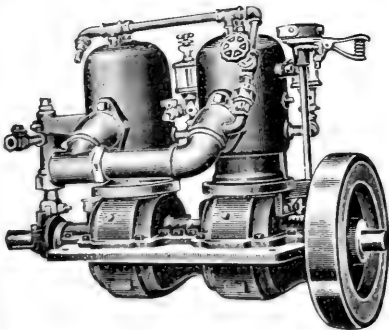

Marine and Stationary Gasoline Engines

FOR ALL PURPOSES

Send for Catalog and Free Engine Trouble Book

Guarantee Motor Co. 65 Bay St. North HAMILTON



BY APPOINTMENT

GREAT
VICTORY
OF



HARDY RODS.

Cane Built and Steel Centre Rods Won ELEVEN out of the Twelve Fly Casting Events at the Great International Fly Casting Tournament, Franco-British Exhibition, leaving ONE for all other English and American Makers.

THE ENGLISH FIELD SAYS: "It is to Messrs Hardy of Alnwick we owe our supremacy as rod makers."

Hardy Bros. International Tournament, Crystal Palace, won 16 championships.

Forty-one Gold and other awards.

Catalog, with flies in colors, sent free to any address.

HARDY BROS., Ltd.
ALNWICK, ENGLAND

LONDON DEPOT: 61 PALL MALL S. W.



22 ft. x 4 ft. 6 in. Speed 13 miles

Launches

From 18 feet to 30 feet in Stock

Speed Launches, Cabin Cruisers and Sailing Yachts built to order.

Our 18 foot Campers' Launch at \$275 is best value in Canada.

SEND FOR ILLUSTRATED CATALOG A.

M. L. Butler, Motor Boats and Yachts
BRIGHTON, ONT.

Korona Cameras Free!

You may secure one for 15 subscriptions to Rod and Gun and Motor Sports in Canada. Write for particulars to-day. W. J. TAYLOR, Publisher, Woodstock, Ont.

When writing advertisers kindly mention Rod and Gun in Canada.



Hey
You Fellows
Why Don't You
Shave Those Faces
of Yours? Look at Mine.



 PRICE 50c

CAMPING, HUNTING OR FISHING

All you need for a clean shave
 every morning is

“SEMPRE GIOVINE”
and a Razor

No Soaps, no brushes, no hot water or any other
 of the usual requirements needed.

HALF A MILLION MEN

are enthusiastic users of Sempre Giovine (pronounced Sem-prey jo-ve-nay.) It is antiseptic, soothing and healing—it makes it possible for the man with a tender skin to have a shave every morning—at home or away—a smooth, clear complexion, and a face free from irritation or soreness.

The full size brick, 50 cts. Ask your dealer.

THREE SHAVES FOR 10c.

If not at your dealers enclose ten cents in stamps or coin for cost of mailing, and I will send you a briquette of “Sempre Giovine,” enough for three of the easiest, smoothest shaves you ever had in your life absolutely free.

Address me personally,

MRS. J. C. CARR, PRES.
MARIETTA STANLEY CO.,
 584 FOURTH ST.,
 GRAND RAPIDS,
 MICH.



We are the Original and Only Manufacturers of
Trolls in Near-Gold Metal

The A. B. Pat. Spear Head Darter, Double Spinner Bass Bait, Trout Spinner and Pearl Wobblers are OUR OWN DESIGN, TESTED AND PERFECTED BEFORE PUTTING ON THE MARKET. Small die work, polishing, plating, etc., done to order. Ask your dealer for Fish-Hawk brand and take no other. Every troll put out under our guarantee. Dealers, DO YOU SELL OUR NEAR-GOLD TROLLS? IF NOT, WHY NOT? Catalogue on application.

Hartung Bros. & Co.
 49-51-53 Waverly St., JERSEY CITY, N. J.

THE CLUB

are the original bottled Cocktails. Years of experience have made them **THE PERFECT COCKTAILS** that they are. Do not be lured into buying some imitation. The ORIGINAL of anything is good enough. When others are offered it is for the purpose of larger profits. Insist upon having the **CLUB COCKTAILS**, and take no other.

G. F. HEUBLEIN & BRO., *Sole Proprietors*
 29 BROADWAY, NEW YORK, N. Y.
 HARTFORD, CONN. LONDON.

Uniform Compression and consequently More Power are obtained by use of the
Compressometer



Price \$5.00

This little instrument enables you to easily and accurately measure the Compression in each cylinder of your motor. It detects at once all troubles incident to your compression, giving you freedom from annoyance of leaky valves, plugs, piston rings, etc. Isn't it worth

the price asked? Supplied with Standard, Metric or A. L. A. M. thread. We also make a 50c closed head spark plug wrench, very useful for motor boatists.

For Sale By

The Brown Co., Syracuse, N.Y.
 500 WATER STREET

Canadian General Electric Co.
 TORONTO

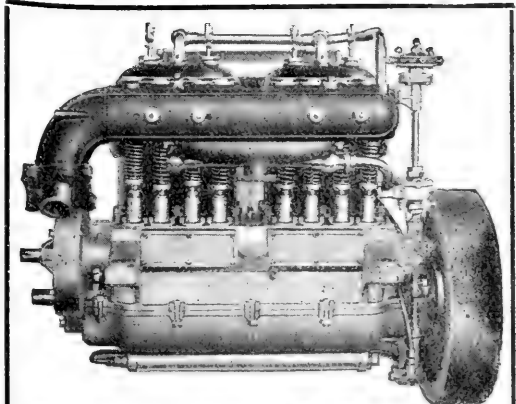

Beaver Motors

WORK LIKE BEAVERS.

- 6 cylinder vertical 4 3-8 x 4 3-4.
- 4 cylinder vertical 4 3-8 x 4 3-4 and 4 3-4 x 5 1-4.
- 2 cylinder horizontal opposed
- 4 3-8 x 4 and 4 3-4 x 4 and 5 1-8 x 4 1-2.
- 4 cylinder horizontal opposed 5 1-8 x 4 1-2.

The 4 cylinder horizontal opposed motor is designed specially for commercial trucks. Centre Crank Oiling Device or Constant Level Splash System. All motors 4 cycle. Write for Free Booklet.

Beaver Mfg. Co. 785 Chase Street
 Milwaukee, Wis.

THIS VIEW OF THE

Incomparable "Syracuse"

Shows the PATENTED WATER JACKETED

CONDENSING EXHAUST,

The Carburetor and Timer, with speed control levers.

The starboard side has nothing but spark plugs.

No Other Motor built does or can condense the exhaust, remove back pressure and relieve stress on cylinders as in the

"SYRACUSE"

In design and operation it is

**SIMPLICITY
SIMPLIFIED**

—and in—

**CONSTRUCTION
UNEXCELLED**

Our catalogue shows these and OTHER SPECIAL FEATURES.

SYRACUSE GAS ENGINE CO.

SYRACUSE, N. Y. U. S. A.



AT the Hamilton Gun Club shoot, Jan. 14, 1909, Howard Bates, of Ridge town, Ont., won the Grand Canadian Handicap at live birds, by a score of 15 straight—winning in the shoot-off by killing 5 birds straight. Mr. Bates shot from the 32 yd. mark. This splendid shooting was done with **The Parker Gun**. This makes the fourth time that **The Parker Gun** has won this premier event.

Mr. Dennis Upson, of Cleveland, shooting **The Parker Gun**, won the first amateur average at targets for the two days' shooting, and H. D. Bates, shooting **The Parker Gun**, won second amateur average for the two days.

This is one more evidence of what we have always claimed—that **The Parker Gun** is the closest and hardest shooting gun made. If you want to be with the winners, shoot a **Parker**.

Send for
Catalogue

PARKER BROS. Meriden, Conn.

ADAMS

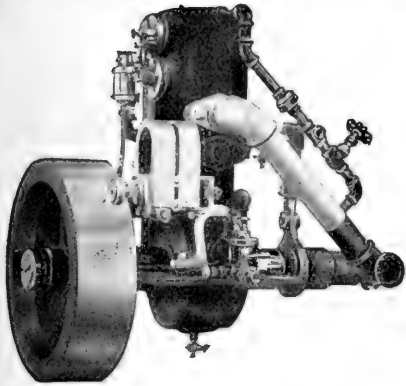

THIS CANADIAN ENGINE

has been in use in all parts of the British Empire for the past five years, and is a reliable, seagoing machine. This reliability is no accident, but is secured by thorough construction and equipment. Made in five sizes from 2 h. p. to 10 h. p. Large stock always on hand for prompt shipment. The Adams catalog fully describes our goods, and is sent free on request. Correspondence solicited.

THE ADAMS LAUNCH AND ENGINE MFG. CO.
 PENETANGUISHENE, ONT., AND VANCOUVER, B. C., CANADA

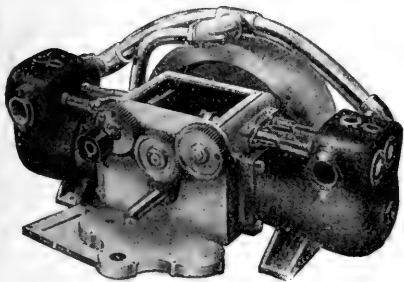

Brennan Standard Motors

Horizontal Opposed for Pleasure Boats. Vertical for High Speed, Heavy Duty and Commercial Use. Practical, Substantial, Serviceable — Built for Real Hard Work, Day In and Day Out.

Brennan Standard Motors are Powerful, Free from Vibration and Economical.

Write for Catalogue—Free on Request

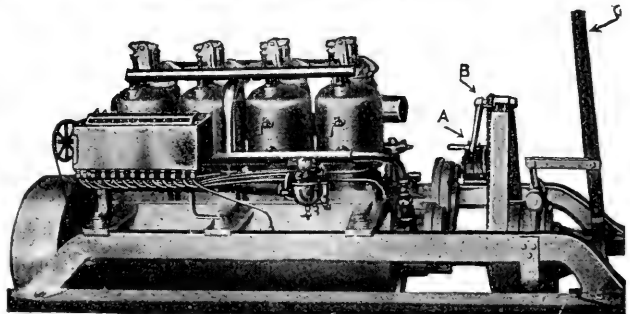

Brennan Motor Manufacturing Co.
 Syracuse, N. Y.

SIZES

Two Cylinder, 4x4, 4 9-16x5, 4 3-4x5, 5x5, 5 1-2x5, 5 1-2x6, 6 1-2x7.
 Four Cylinder, 4x4, 4 9-16x4, 4 9-16x5, 5x5, 5 1-2x6, 6x6, 7x6.
 Six Cylinder, 7x7 and 8x8.

Northern and North-Western Raw Fur Shippers



Higher Than a Cat's Back

The Square Deal House

The Square Deal House

Lynx, Fox, Fisher, Wolves

sold at terrific high prices in January and March in London, and we have demands for more skins than we can get. Ship them in to us. You will be surprised at the high prices we will pay you.

Especially High Prices Paid for Muskrats

Every shipment is held by us ten days subject to your approval of our returns.

Small parcels from great distances ship by mail.

Write us and we will give you prices that will astonish you for above goods, and any others that you may have.

WEIL BROS. & CO.

Fort Wayne, Indiana

"The Square Deal House"

\$25.00 —THE— \$25.00

Marshall Sanitary Mattress

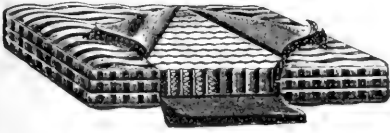

THE "MARSHALL SANITARY" is the only mattress which combines PERFECT COMFORT with perfect hygiene construction, for it is the ONLY VENTILATED MATTRESS.

IT WILL NOT SAG OR GET HARD.
IT IS PERFECTLY RESILIENT.
IT CONFORMS TO THE SHAPE OF THE BODY, SUPPORTING IT AT ALL POINTS.
IT IS GUARANTEED FOR 5 YEARS.
NO OTHER MATTRESS IS GUARANTEED BY ITS MAKER.

Does this interest you? Then send for BOOKLET C.

Sold By Dealers Everywhere for \$25.00.

The Marshall Sanitary Mattress Co.

TORONTO.

Factories—Chicago, Ill.; London, Eng.; Toronto, Can.

Trade Mark Reg. U.S. Pat. Off.

Chiclets

REALLY DELIGHTFUL

The Dainty Mint Covered Candy Coated Chewing Gum

Particularly Desirable
after Dinner

YOUR FRIEND GOING TO CAMP KNOWS the value of Chiclets in his outfit. Keep the mouth moist and be of good cheer.

Put up in little green bags for a nickel and in 5, 10 and 25 cent packets by Frank H. Fleezer & Company Incorporated
+ Philadelphia, U. S. A. +
+ and Toronto, Canada. +



"Star Brand" Breakfast Bacon

is the
BEST BACON.

Made from Choice Canadian Pigs, Selected and cured under inspection of the Dominion Government, the quality is unsurpassed.

Ask your grocer for it, or send direct to

F. W. Fearman Co., Ltd.
Hamilton, Ontario

The New Model

Rundel Automatic Stropper

Strops all safety razors, both single and double edge. Absolutely automatic; cannot cut strop or run off strop. Order through your dealer or we will send stropper and strop complete prepaid on receipt of \$3.00. Descriptive literature on request. Liberal discount to the trade.

RUNDEL SALES COMPANY

950 Central Building Rochester, N. Y.

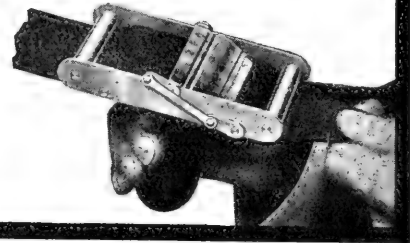

TO anyone sending in five subscriptions to Rod and Gun we will send Free one of Betzler & Wilson's high grade fountain pens.

When writing Advertisers kindly mention Rod and Gun in Canada.

The Canadian Reo

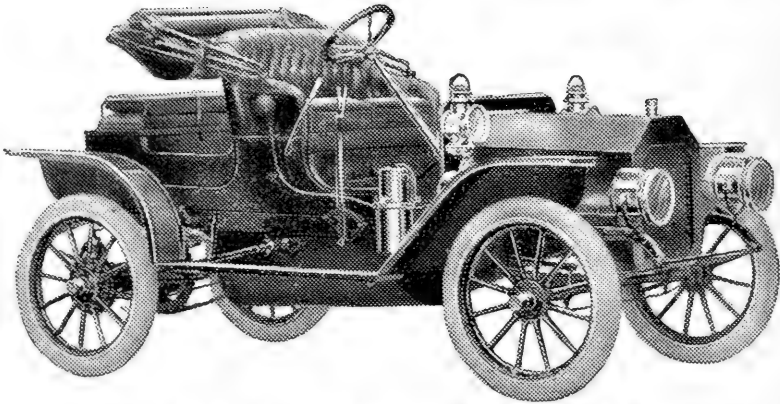

20-22 H.P. Touring Car or Roadster \$1,250

REO

The Car That Gets You There and Back

without requiring more skill than is involved in filling the tanks and seeing that it is properly lubricated.

THE BEST AGENCY PROPOSITION IN CANADA.

*Write for a Complete Catalog.
Also "Two Weeks—A Shocking Tale"*

Address "Selling Dept."

**REO MOTOR CAR CO. OF CANADA
LIMITED**

ST. CATHARINES, ONT.

Clarke's Moccasins

For Snow-shoeing, Ski-ing, Tobogganing, etc.

Handsome, shapely, comfortable, and durable. Look well, fit well, feel well, and wear well. Made from No. 1 leathers, which are selected specially for this purpose, and will outwear any of the ordinary leathers put in Moccasins. Every pair is made on a good-fitting last, that is well gauged, so that we can assure you of a good comfortable fit for either men, women or children, as well as a neat, good appearance on the feet. Can be had in either Buck, Elk or Bull-hide leathers, and made with either plain or fancy embroidered toe, and either part or all wax thread sewn. All branded A R C Brand and Guaranteed.

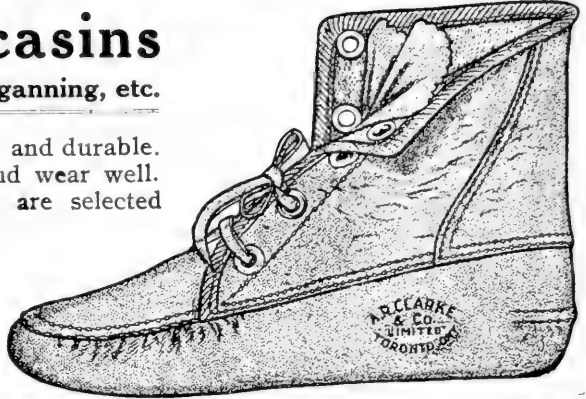

Sold by all Dealers Everywhere Throughout Canada



A. R. CLARKE & CO., LIMITED
TORONTO, CANADA

DEAN'S

Close Ribbed and Metal Joint Construction

A thin strip of hard brass, full length of the canoe or boat, shaped like figure 1 in the cut, the two turned pressed into the wood at each side of the joint. This is held into place by the ribs, which are only $2\frac{1}{4}$ inches apart. There are no cross battens to obstruct the cleaning as there are in other canoes and lapstreak boats.

In an ordinary lapstreak boat there are about 240 holes under the ribs, which makes a lot of trouble to clean, and when the water is emptied out the dirt catches under the ribs or against the cross battens. No trouble like this with Dean's Metal Joint System.

Then they have twice to three times the number of ribs than other makes, which strengthens them beyond comparison.

Carefully Examine the Cut
Send for 1909 Catalog—It's a Real Treat

Walter Dean
1751 Queen Street W., TORONTO

WHY

Dean's Metal-Joint boats are superior to Lapstreak

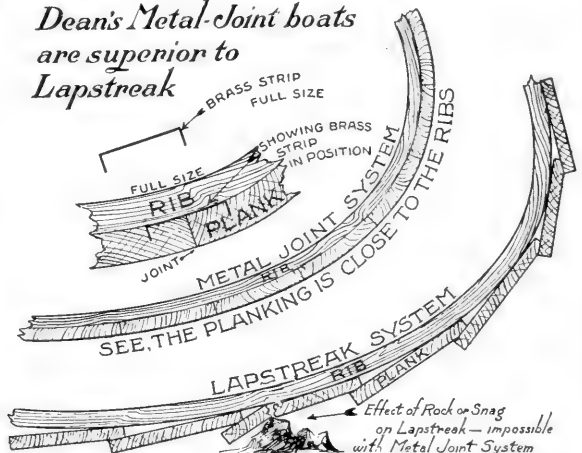

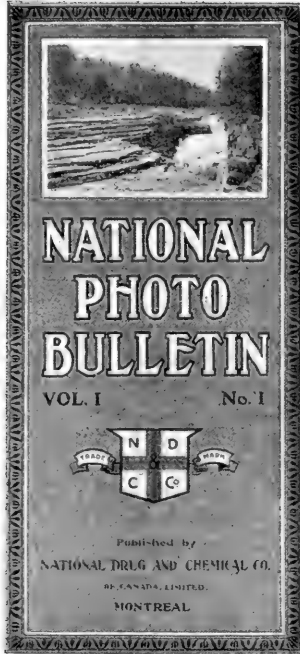

We Will Send the National Photo Bulletin to Any Amateur Photographer for One Year Absolutely Free

The National Photo Bulletin is published monthly by the Photographic Department of the National Drug & Chemical Co. of Canada, Limited, and is sent free to any one who is interested in photography.

This publication contains seasonable matters of interest to photographers and describes all the latest apparatus, materials, and methods. One page is set aside for the readers use, where questions are answered by experts in photography.

Each month formulae and processes for developing and finishing are given and fully described and explained.

Several competitions for valuable prizes are now open and particulars are fully given in its pages.

No amateur photographer should be without the monthly visits of the National Photo Bulletin, which he can get by filling out and mailing the attached coupon, to our Photo Department.

**National Drug & Chemical Co.
of Canada, Limited, Montreal**

Please
Write
Plainly

Date.....

Photo Dept.,
National Drug &
Chemical Co. of
Canada, Ltd., Mont-
real, P.Q.

Gentlemen,—As per your offer in Rod & Gun in Canada please send me free of charge your monthly publication, the "National Photo Bulletin."

Name.....

Address.....

Dealer's Name.....

MARBLE'S GAME GETTER GUN

Target Rifle or Pistol---Big Game Gun---Shot Gun

MODEL 1908

22 caliber rifle barrel and
44 caliber smooth barrel.
Brls. 12 in. Wgt. 2 1/4 lbs.
Shoulder Swing Holster



THE ONLY ALL PURPOSE GUN

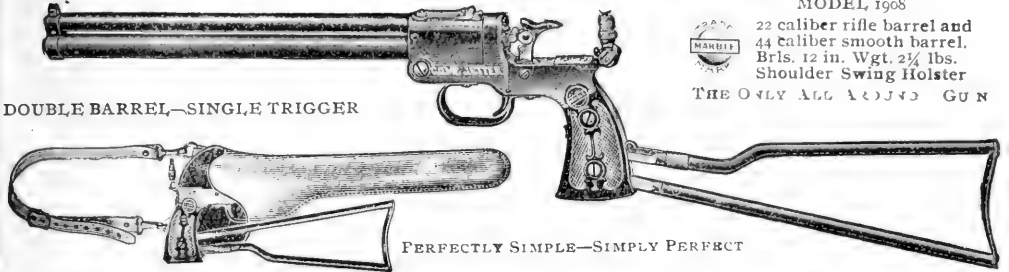

DOUBLE BARREL—SINGLE TRIGGER

PERFECTLY SIMPLE—SIMPLY PERFECT

This one Gun Shoots .22 Short, Long and L.R., .44-40 Shot, and .44-40 Round Bullet

An average of 60 No. 8 shot and 120 No. 10 strike a 12 inch square at 50 feet. The No. 8 shot range from 50 to 70 p target. There are about 100 to the load. The .44 barrel is cylinder bored.

Flying or running game can be bagged as easily as with any gun of its bore.

A .44 ball penetrates 6 inches of pine at 15 feet. Will kill a deer or black bear at 40 or 50 yards. Most deer are killed within 50 yards.

The .22 barrel shoots as strongly and accurately as any make or length of barrel of its caliber.

MARBLE'S GAME GETTER is the ideal arm for the Fisherman, Motorist and Vacationist, and all classes of people whose business or pleasure calls them to the woods, fields or waters. It is the long looked for "Trappers Gun."

The Big Game Hunter with a GAME GETTER for a side arm secures with little noise and no mutilation the small game he runs across and enjoys target practice without the jar and expense of firing his heavy ammunition.

The GAME GETTER can be safely used with smokeless powder. The recoil is slight. Gun can be opened as quick as a wink, but never accidentally. Either barrel is used without any change of sight or adjustment.

The Striker on Hammer is quickly set with the thumb for either barrel or at SAFE. The Folding Stock locks automatically at any drop for which it is set. Is easily removed.

With the holster hung over shoulder and under coat the GAME GETTER is invisible, but can be speedily drawn and very handily used in one hand with stock hanging down or thrown to position. In either position the stock only aids in the balance of the gun.

The GAME GETTER'S utility, simplicity of construction, careful design, perfect safety, absolute reliability and superior accuracy are the qualities which are making it famous the world over.

This gun is fully described in FREE CATALOG of Marble's 60 "extra quality" Specialties for Sportsmen.

Sold by all Dealers or direct from the Makers

MARBLE SAFETY AXE COMPANY, 101-129 Delta Ave., Gladstone, Mich., U. S. A.

DO IT NOW

It is about time to think of BOATING. If you want to own the



Neatest,
Easiest Running
and
Best Built Boat

on the water this Spring, then buy a "PETERBOROUGH." Order now and your boat will be ready for you when you want it.

We Build
CANOES,
SKIFFS,
DINGYS and
LAUNCHES

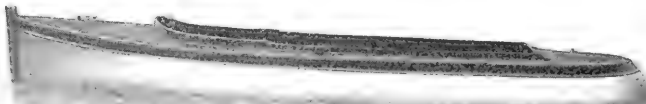

Write for Catalogue

PETERBOROUGH CANOE CO., LIMITED

PETERBOROUGH, ONTARIO, CANADA

When writing Advertisers kindly mention Rod and Gun in Canada.



Indestructible!

The clear, full, brilliant tone of Columbia Indestructible Cylinder Records is the best reason for their growing popularity.

But it's a fine thing to know they *can't break*, no matter how careless you may be, and that they will never wear out, no matter how many times you play them.

45 cents! Write for a catalog!

A splendid repertoire to choose from—and we are adding to it right along.

Toronto Phonograph Company, Ltd.

40 MELINDA STREET, TORONTO, CAN

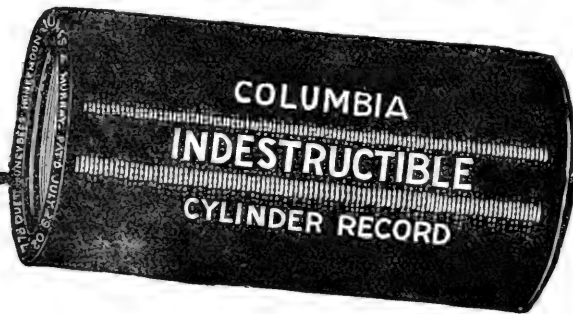

SPECIAL OFFER

A sample Indestructible Record will be mailed free to every owner of a Cylinder Machine who will mail us this advertisement and state the make of his machine and from whom it was purchased.

RETAIL STORES OF

Toronto Phonograph Co., Limited
190 Sparks St., Ottawa, Can.
205 Dundas St., London, Can.
474 Queen St. W., Toronto, Can.
264 Yonge St., Toronto, Can.

DEALERS WANTED

Exclusive selling rights given where we are not properly represented.

Write for particulars.

Address all Communications to

TORONTO PHONOGRAPH CO., LIMITED

40 MELINDA STREET, - TORONTO, CAN.

Mail Order and Wholesale Department

"Has Given Entire Satisfaction"

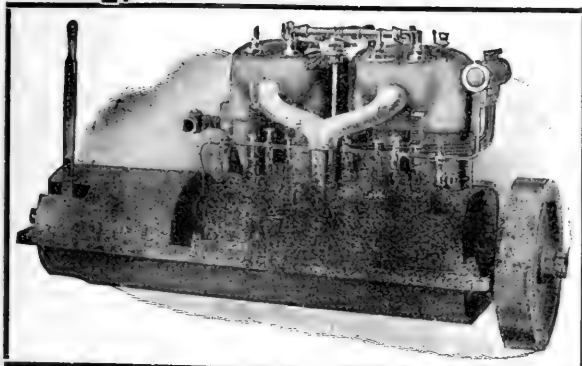

Here is a letter right to the point. **Entire satisfaction** is a strong term and covers **everything**. We'll be glad to send you copies of letters received from all parts of the United States praising the merits of Sterling engines. But read this one first:

"Morgan City, La.,
"Jan. 23rd, '09.

"Sterling Engine Co.,
"Buffalo, N. Y.

"Gentlemen,—It gives me pleasure to state that your 4 cyl. 4 cycle 30 H.P. engine, which I purchased six months ago, has given entire satisfaction. I only regret that I did not purchase a six cylinder engine.

"(Signed) "E. A. PHARR."

Heavy Duty Engines, 12, 40, 60 H.P.
Semi Heavy Duty Engines, 18, 25, 30, 35, 45 H.P.
Speed Engines, 25, 40, 45, 55, 65, 100 H.P.
Two Cycle Engines, 2 1-2 to 9 H.P.

Sterling Engine Co., Buffalo, N.Y. U.S.A.

Member National Association of Engine and Boat Manufacturers

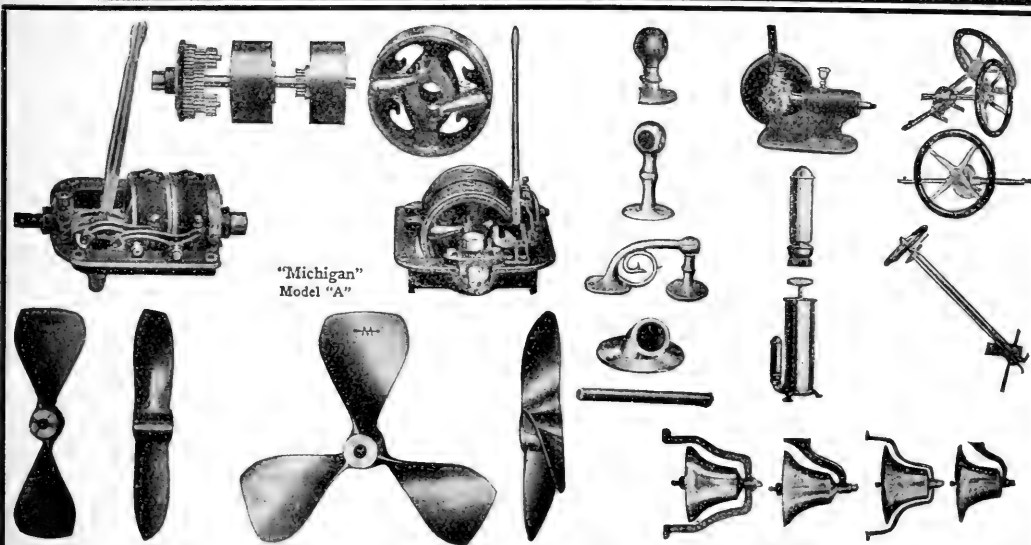

"Michigan"
Model "A"

LOOK HERE Get your supplies of us. You want the latest up-to-date supplies—we have them at prices that are right and will interest you. Every boatman should have our 60 page catalog full of valuable information on five types of reverse gears, including two speeds ahead and self locking, six speed wheels, a weedless wheel and reversible and up-to-date marine hardware. Send for catalog today.

MICHIGAN WHEEL CO.

Canadian Distributors, Jno. Millen & Son, Ltd., Montreal, Toronto, Vancouver.

Grand Rapids, Mich.

When writing advertisers kindly mention Rod and Gun in Canada.

ATTENTION

Boat Builders and Agents

We want good live representatives to handle our line in your locality. We have the best selling, best running, best appearing marine engine on the market. Write for prices and terms.

Lockwood-Ash Motor Co.
Jackson, Michigan, U.S.A.

The Kent Double Spinner Baits

If you want the best Bass Bait on the market try a Kent Champion Floater.

Manufactured Exclusively by

SAMUEL H. FRIEND
KENT, OHIO, U.S.A.

Postpaid for 60c. Send for booklet of baits.

FISHING RODS

The name "DIVINE RODS" is a guarantee of Quality, Workmanship and a positive assurance of a fishing trip without disappointments which are due to the breaking of the rod, and many annoyances usually found in cheaper makes.

Our Specialty is Split Bamboo, Bethabarra Greenhart, Dagama and Lance Wood.

Don't attempt to make up your Camp or Vacation Outfit until you have consulted our catalogue, sent free.

The Fred. D. Divine Co.
73 State St., Utica, N. Y.



Sta-Rite

(Trade Mark)

Ignition Plugs

are now repaired perpetually, free of charge, when returned to our factory, because "THEY STAY RIGHT THE LONGEST."

—THE—
R. E. Hardy Co.

INCORPORATED 1900

Factory—201 37th St., Brooklyn, N.Y.
309 Fisher Bldg., Chicago

AGENTS:

Canadian-Fairbanks Co.
Montreal and Toronto

RAINO WATERPROOF CLOTHING

What is Raino?

Raino is the most satisfactory waterproof clothing known to fishermen, hunters, motor boat men, automobilists, and indeed to all who follow outdoor sport or pursuits, and no kit is complete without this perfect protection against bad weather.

Raino does not get sticky nor soil clothes. Neither camp fire nor hot rooms can harm it, and is easily mended on any sewing machine when torn or worn.

Raino becomes more pliable with use, and there is infinitely better style to these garments than the awkward suits hitherto worn.

We want every one interested to possess our catalogue, which with sample of material may be had for the asking

Send today for free catalogue. Dealers also can be supplied.

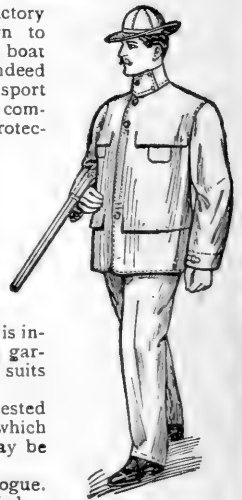

RAINO CO.
761 S. HALSTED ST., CHICAGO, ILL., U.S.A.

\$60⁰⁰ AND UPWARD **COMPLETE
READY TO
INSTALL**
IN YOUR
BOAT

GRAY MOTORS

Made In The Largest And Most
Up To Date Plant In The World

DEVOTED EXCLUSIVELY TO THE MANU-
FACTURE OF TWO CYCLE MARINE MOTORS

"The Motor
of
Quality."

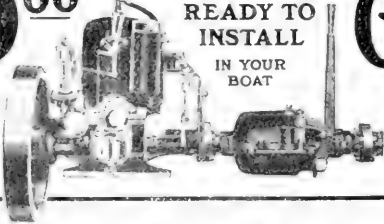

Why the "Motor of Quality?"

RAINMAKER—Speed 23 1/2 miles per hour. Equip-
ped with a 24 H. P. GRAY Motor.

Then why so low a price?

Because we built and equipped a modern plant—the largest in the world devoted exclusively to the manufacture of two-cycle marine motors—especially to build Gray Motors—NOTHING ELSE.

It is simply a question of quantity. We are willing to take a very small margin on each motor and our enormous output gives us a satisfactory profit in the aggregate.

Because we devote our entire capital and energy in the endeavor to produce the best motor it is possible to build.

The Gray Motor could not be made any better if it cost you three times as much—if it were sold for a higher price we could not sell enough to keep the big plant busy.

Because we concentrate on this one motor.

So the great output gives us the low cost of manufacture, and quality and low price gives us the necessary market for the great output.

Because we use only the best material money can buy
3 to 40 H. P. Write for catalog and story of how these motors are made.

GRAY MOTOR CO., 64 Leib Street, Detroit, Michigan.

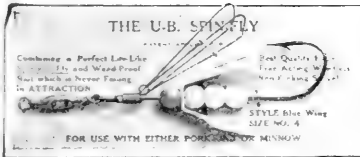

Two Popular U-B Specialties

THE U-B LIVE FROG HARNESS holds the frog without hooking and keeps it alive. THE U-B SPIN-FLY is made with blue, white and red wings and colored beads. Leading dealers or by mail postpaid.

Unkefer & Bradley

MANUFACTURERS

91 Dearborn St., CHICAGO

U-B Live Frog Harness



CUT SHOWING FROG IN HARNESS

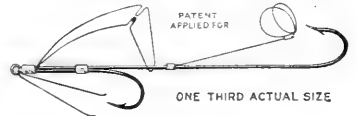

Price 35c

The U-B Spin-fly is the most attractive and effective spinning bait ever invented. Life-like in appearance and closely resembles a fly or bug struggling in the water. Weed-proof. Above cut about half actual size. Price 25c

The Capital Boat and Canoe Works Bank Street Ottawa

Builders of fast Gasoline Launches, Motor Canoes, Skiffs and Paddling Canoes

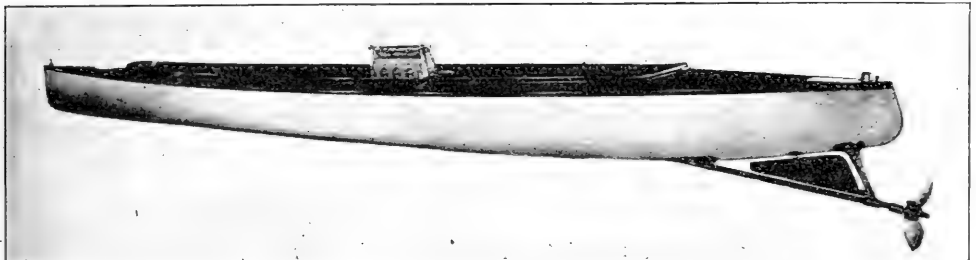

A First Class Motor Canoe 20 ft. x 34 in., Two Cycle Motor, Complete for \$150.00
Speed 12 to 14 Miles per hour. Write for Catalogue.

PERFECTION

Marine Engines

2 H.P. \$45
P.

Complete

ready to install

Our plan of building Marine Engines in quantities in one of the largest and best equipped plants in the world enables us to make low prices without sacrificing quality. "Perfection" design is standard. "Perfection" workmanship and finish EQUALS THE MOST EXPENSIVE. Cylinders and Pistons ground to a mirror finish; Cylinders 3 in. bore x 3 1/4 inch stroke; best Babbitted Bearings, elevated Commutator with enclosed Gears; choice of Float-feed Carburetor or Improved Generator, and in every detail equal to the most costly. Our "Perfection" 2 h.p. will deliver more power, last longer and give greater satisfaction than any other Engine you can buy at the price or anywhere near it. Perfection Engines are built for service—that's why they satisfy.

Write for Catalog and "Evidence from the Users."

Caille Perfection Motor Co.

1354 Second Ave., Detroit, Mich.

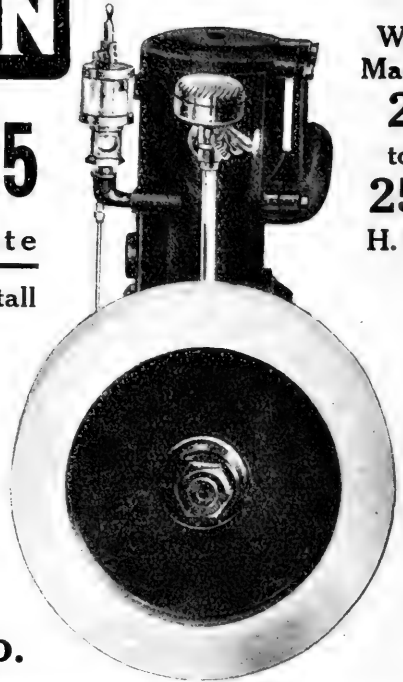

We
Make
2
to
25
H.P.

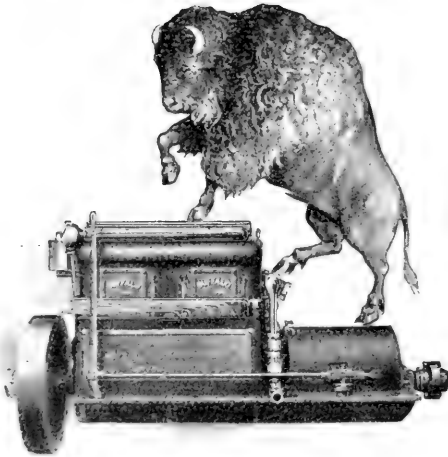

Engine shown is Regular Type 4-cylinder, built in 10, 15, 20, 30 and 40 H.P. sizes.

Important and distinct improvements, both in construction and equipment and "BUFFALO QUALITY" throughout, which means highest grade in every detail of workmanship and material, go to make our 1909 Models world beaters.

1909 Catalogue, giving full information, sent free on request. INVESTIGATION NOW MAY SAVE YOU REGRET LATER

"Personification of Completeness
in Progressive Marine Engine
Construction."

This is the comment of a prominent boating authority after looking over the "BUFFALO" 1909 line, which now includes engines for any type of boat for any class of work.

Regular Type Medium Weight Engines—
Sizes, 2 to 100 H.P., 2 to 6 cylinder.

Slow Speed Heavy Duty Type—Sizes, 4 to 54 H.P., 1 to 6 cylinder.

High Speed Light Weight Type—Sizes, 50 and 75 H.P., 4 and 6 cylinder.

BUFFALO GASOLENE MOTOR CO.

1218-1230 NIAGARA STREET, BUFFALO, N.Y.

Championship of
the World



Olympic Games
London, 1908

THE LEFEVER GUN WINS

BECAUSE the taper system of choke boring was originated and first adopted in the *Lefever* factory, and is best understood and practised by the men who make *Lefever* guns. The *Lefever* gun won the High Amateur Average of the United States for 1908 in the double bird events—positive proof that *both* barrels of the *Lefever* are bored uniformly true, that *both* barrels give the penetration and the pattern needed to win consistently.

THE LEFEVER GUN LASTS

Because the patented compensating features of its action takes up wear in every direction, and it can never shoot loose.

No other gun, American or foreign, is as simple in its construction or as positive in its action. The new *Lefever* cocking hook, one solid piece of steel, does the work of from 18 to 25 parts in other high-grade shotguns. Cocks both hammers, ejects the shells and forms a check to remove all strain from the hinge joint. Other features are, skeleton rib and heavier barrels than used on other guns of the same weight, dovetail top fastening, locks attached to frame and independent of lock-plates, trigger pull can be regulated to any desired weight by eccentric screw, and gun can be opened with one hand, leaving other hand free to put in shells.

Our catalogue will tell you many other things you should know before you buy a gun. It explains the whys and wherefores, and will convince you that it pays to buy the best. Shall we send you one?

LEFEVER ARMS CO.

20 Maltbie Street - - Syracuse, N. Y.

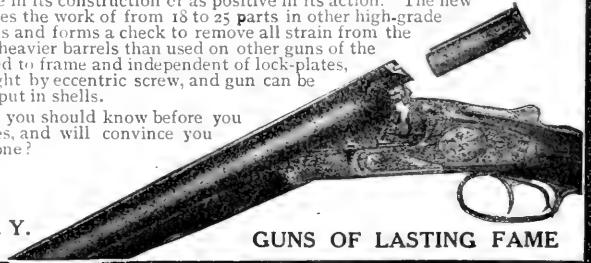

GUNS OF LASTING FAME

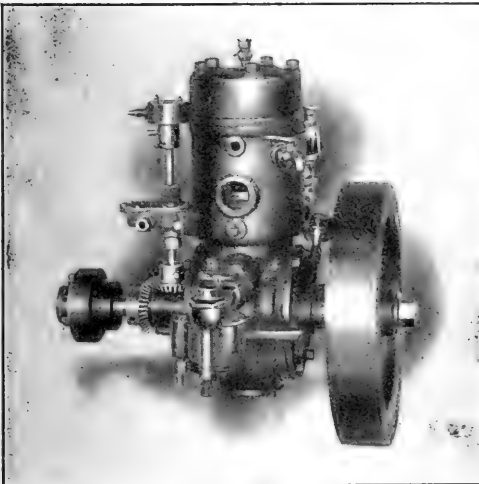

\$100.00

For this 4 H.P. Engine, complete; will drive a

21 Ft. Launch

Equipped with this motor, will make from 7-10 miles per hour, depending on the model of the boat.

— The Famous —
Canadian Beaver

Made in six sizes. The new reduced price is \$25 per horse power for the complete outfit, including ignition equipment, three blade bronze propeller and shaft. Everything high grade and only the best material obtainable.

Send for New Description and Price List

The Sherman-Cooper Co. TORONTO 1059 EASTERN AVENUE

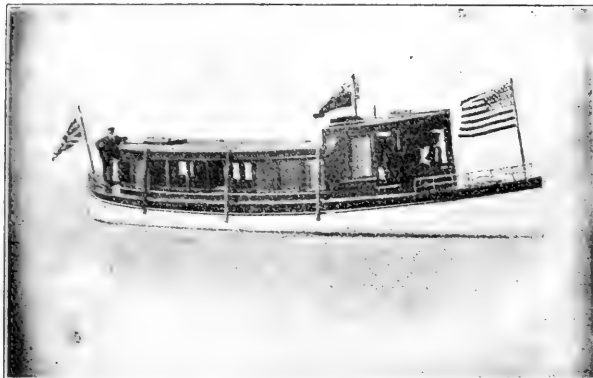

**HIGH-GRADE
GASOLINE LAUNCHES**

From \$175.00 up

Rowboats and Canoes

H. E. GIDLEY & CO.
DEPT. R, PENETANGUISHENE, ONT., CAN.

IF YOU HAVE A **Coller Attachable Grip** for your casting rod then you are **STRICTLY IN IT**; if you have not then you are losing the real comforts of fishing. This rubber handle is placed on any rod in three seconds; fits close to the reel-seat; does not overweigh the rod like other forward grips. Thousands of fishermen are using this grip, and will swear by it to a man. **ORDER ONE TODAY.** Gray rubber 50c; red rubber 60c. Sold by all dealers; if not send P.O. order direct to



THE COLLER RUBBER GRIP CO.
Dept. 13, Coldwater, Mich.



*Lyman sights for ever
Your faithfully
J. Stuart White
Dunedin New Zealand*

Send for our New Illustrated 1909 Catalogue.

THE LYMAN GUN SIGHT CORPORATION. Middlefield, Connecticut, U.S.A.



Have you a Canoe for the Fishing Season? If not--send for our Catalogue.

The William English Canoe Co.
PETERBOROUGH, ONT.

SPEED BOATS — OR — WORKING BOATS

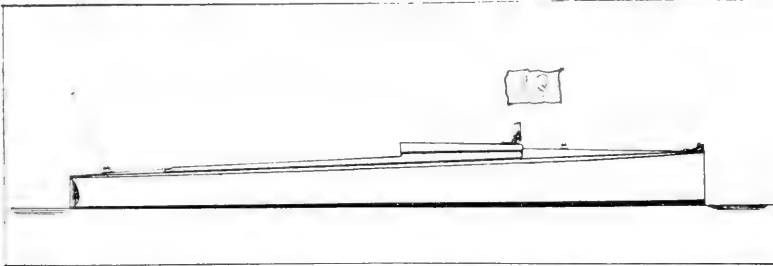

27x5 ft. fast runabout for Georgian Bay uss, 18-25 H. P. Sterling Motor. Speed, 19 miles.

EXPERT REPAIRING

If your present Motor does not give you satisfaction, send it to us for overhauling. We will guarantee results.

Write for Engine Catalogues.

WE ARE THE LARGEST DEALERS
IN
IMPORTED MARINE ENGINES
IN CANADA.

ROBERTS MOTORS

TWO CYCLE THREE PORT. 1½ to 60 H.P., 1-6 Cylinders.

STERLING MOTORS

12-100 H. P., Four Cycle Speed and Heavy Duty.

EAGLE MOTORS

TWO CYCLE
TWO PORT

For Working Boats

The Marine Construction Co.

Successors to
Nicholls Bros. Ltd.

Lake St. (Foot of York)
TORONTO

**Tudhope-McIntyre
Motor Carriage**

\$550

Complete with solid rubber tires, horn, wheel steer and 3 lamps.

This \$550 "Tudhope-McIntyre" is just what most men have always wanted—a Motor Carriage that will make 25 miles an hour if necessary—that is practically trouble-proof—and is far cheaper than a horse and carriage.

There are no tire-troubles with Model H.H. Tires are solid rubber—can't puncture—rocks, ice, etc. have no terrors for them.

With these tires, high wheels

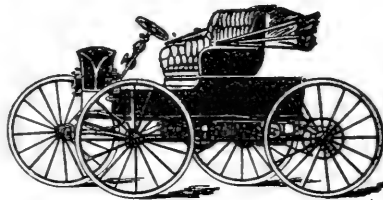

and the 12 horse power motor, this carriage will go anywhere that a horse can.

Fitted with Chapman's Double Ball Bearing Axles, that Run a year with one oiling.

For down-right economy, Tudhope-McIntyre Model H H is a wonder. Hundreds of road tests have proven that this \$550 Motor Carriage will run 30 miles on one gallon of Gasoline. 15 models from \$550 to \$1000.

Dealers, and Others

who can handle a reasonable number of these cars, should write us at once for terms and territory.

1

THE TUDHOPE-MCINTYRE CO.,

WRITE DEPT R.G.

ORILLIA, ONT.



There's no dark room with a **KODAK TANK**

Every step is simple and easy but, more than that, it means *better pictures*. The success of the tank development idea has now been absolutely proven by the fact that many leading professional photographers, although *they* have every dark room convenience, use our tank system of development for all of their work. If tank development is better for the skilled professional, there's no question about it for the amateur.

The Experience is in the Tank

Ask your dealer, or write us for our booklet, "Tank Development." It tells about the modern methods of developing Cartridge Films, Premo Film Packs and Glass Plates.

CANADIAN KODAK CO., LIMITED
TORONTO, CAN.

Palmer's Moosehead Brand

Waterproof Sporting Boots

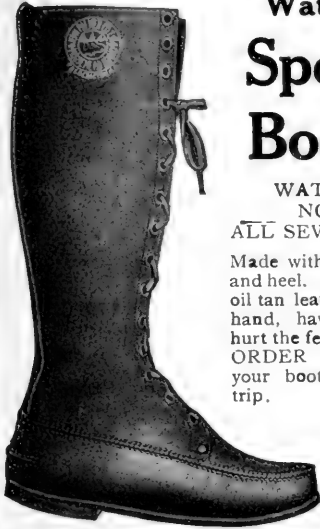

WATERPROOF
NO NAILS
ALL SEWED BY HAND

Made with or without sole and heel. Sole is of flexible oil tan leather, sewed on by hand, having no nails to hurt the feet.

ORDER NOW and have your boots ready for any trip.

Catalogue showing different styles and containing self measurement instructions forwarded on application to

JOHN PALMER CO., Limited
Fredericton, N. B., Canada.
MANUFACTURERS OF OIL TAN FOOTWEAR

CHARLES LANGASTER

TO H. M. THE KING

Est. 1836
2 piece
jectors



\$68.00
\$22.26

"THE ART OF SHOOTING" Seventh and Revised Popular Edition, 2/8; Postage 6d extra.

ILLUSTRATED PRICE LIST FREE

11, PANTON STREET, HAYMARKET, LONDON, S. W.
(Opposite The Comedy Theatre.)

A King Air Rifle

Will be given FREE to anyone sending

3 SUBSCRIPTIONS to

ROD AND GUN AND MOTOR SPORTS IN CANADA

The King Air Rifle is a winner. Every boy who is anxious to become proficient in shooting should take advantage of this opportunity to own one. No difficulty in securing the 3 subscriptions. Send for sample copy to show prospective subscribers. DO IT NOW.



Fish Will Bite

like hungry wolves any season if you use MAGIC FISH-LURE. Best bait ever discovered for attracting all kinds of fish. If you like to pull out the finny beauties right and left, and catch a big string every time you go fishing, don't fail to try this wonderful bait. Enough for a whole seasons good fishing sent by mail for 25cts. Perfect satisfaction or money refunded. Interesting booklet and price list of fishermen's specialties free. Write for them. J. F. GREGORY, Desk P, St. Louis, Mo

Every Owner of a Two Cycle or Four Cycle Engines Should Have a Brown Compressometer

to ascertain the condition of your motor and find out if compression in all cylinders is correct and uniform. In exchange for EIGHTEEN NEW SUBSCRIPTIONS we will send one of these useful contrivances, manufactured by the Brown Company, 521 East Water Street, Syracuse, N. Y.

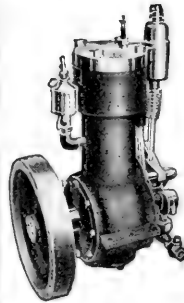

The "Dunn" Marine Motor

Four-Cycle Reversible, Outfit Complete \$42.50

Engine Only, \$38.00

This 1 3/4 actual h. p. Four-Cycle Motor with best coil, batteries, shaft, screw, and muffler, tested ready to install in skiff or launch. Weight of motor 80 pounds. I also build two and three cylinder and stationary motors. Pulley furnished where motor is to be used for stationary work.

Bore 5 1/4 in.
Stroke 4 in.

Walter E. Dunn
Ogdensburg, N. Y.

For Sale—Twenty-three Foot Launch

Up to date in every particular. Equipped with a "Leader" Horizontal Opposed Four Cycle Marine Engine—six horse power. Outfit entirely new. Price exceptionally reasonable. For further particulars as to price, etc., apply to

ROSS CANOE CO., ORILLIA, ONT.

WATCH IT WOBBLE!

No artificial bait ever invented so quickly attracts bass, pickerel and all game fish as our Famous Glittering Pearl Wobbler Spoon, which in the water has an eccentric wobbling motion much more effective than spinning and catches fish where everything else fails. BY MAIL POSTPAID 25 cents with our large illustrated catalogue of fishing tackle.



R. G. DOERING & CO., 564 Liberty Ave., Brooklyn, N. Y.



We Can Show You many letters from users of the Common Sense Plug

that would leave no doubt in your mind of its superiority. One man, Mr. Wm. E. Moore, Alexandria, Va., says: "I tried every Plug on the market, buying \$27.50 worth of different makes in the last three months, but they would either burn up or blow out. Since putting your Plugs in I have not had one minute's Plug trouble."

THIS IS THE PLUG THAT OUGHT TO APPEAL TO YOU. PRICE \$1.00

C. F. SPLITDORF

Wilton Avenue and 138th Street
Branch, 1679 Broadway

NEW YORK

MR. HUNTER OR FISHERMAN



DON'T YOU KNOW that WE MAKE the BEST BOAT on earth for you. They are NOISELESS in the WEEDS. PROPEL EASIEST. Are SAFEST and most DURABLE. Will OUTLAST steel or wood boats, and carry more load. GALVANIZED and TEMPERED STEEL FRAME, BEST CANVAS BODY. Set up in ten minutes. Folds compactly. Checks as baggage. Write us for Catalogue A.

Life Saving Folding Canvas Boat Co., Kalamazoo, Mich.



GLOVER'S IMPERIAL DOG REMEDIES.

The result of twenty-five years' experience
in the treatment of

SICK DOGS.

FOR SALE BY DRUGGISTS AND DEALERS IN
SPORTING GOODS IN CANADA.

FREE BOOK ON
DOG DISEASES AND HOW TO FEED
On application to

H. CLAY GLOVER, V.S., 118 W. 31st St., New York
U. S. A.

Beers Brothers' THERMOSTAT

You need one in your house.
Keeps the temperature exactly right, day
and night. Saves coal, saves worry,
works on Furnaces, Hot Water or Steam
Heaters. Any one can attach.

It Tends the Heater.

The simplest apparatus made: guaran-
teed to work perfectly and last four
years. Big and little homes need it.
Send today for booklet.
BEERS BROS. THERMOSTAT CO.
1160 Portland Ave., Rochester, N.Y.

Catch 'em and Hold 'em.

THE NEWHOUSE TRAP

is absolutely reliable. Never
fails to hold the game. Positive
in action, easy to set, will not
get out of order.

Made in all sizes to catch any-
thing from a rat to a bear.

Send for Catalogue

ONEIDA COMMUNITY, Ltd.
Niagara Falls, Ontario

Send for our free Boat Book

Do not think of buying
a launch until you see our



**Four Launch
Bargains**

ONLY \$121 for

this complete 16 foot launch. 2 1/2 H. P. guaranteed, self-
starting engine.

\$144 for 9 1/2 mile per hour "Speedaway." **\$153** for canopy
topped "Winner." **\$160** for Auto-topped 3 H. P. "Comfort."
All 16 feet in length. Engine result of 30 years experience.
Weldless wheel and rudder. Shipped immediately on approval.
Send postal for our handsome catalogue today—it's a gem.

C. T. WRIGHT ENGINE CO.

1004 RIVER ST.,
GREENVILLE, MICH



Don't Worry About the Rain!
 or the snow or sleet of good wildfowling
 weather, or the twigs and rushes of the duck
 blind, or the drifting sand of the goose
 pit—nothing can get into the action of a

Marlin

Repeating Shotgun

The *Marlin* shotguns shoot hard and close and are built with an eye to overcoming weaknesses of the average "pump" gun. The breech is completely closed in by the bolt and the top of the breech block is solid, so that no snow, sleet, twigs or any foreign objects can clog the action. This solid top prevents water from running down into the magazine and swelling the shells—one of the most aggravating things that can happen with a repeating shotgun.

With one-third less parts than any other repeater, the simplicity and strength of mechanism insures perfect operation; double extractors pull any shell; and automatic recoil safety lock removes all danger from hang-fires, making the *Marlin* the safest breechloading gun built.

Send to-day for our 136-page catalog, describing the full *Marlin* line. Enclose 3 stamps for postage.

The Marlin Firearms Co.
 67 Willow St. NEW HAVEN, CONN.



Are You Acquainted with the Features of the "Oldsmobile"

Reliability
 Accessibility
 Comfort

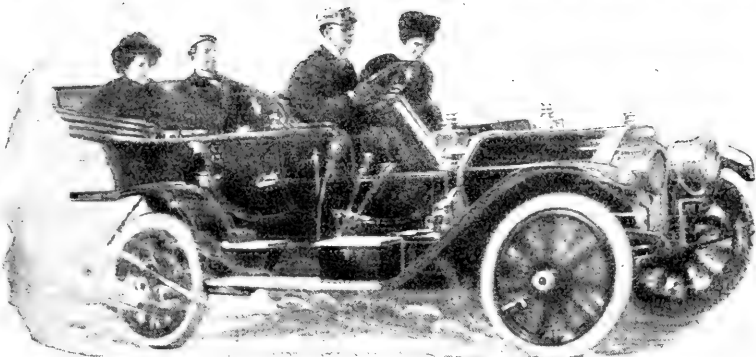

Handsome in Appearance
 Smooth Running
 Odorless

The "Oldsmobile" Touring Car for 1909—Model D—Price \$3,000

"The Logical Car at a Logical Price"

The Oldsmobile Company of Canada, Limited

FREDERICK SAGER
 Manager

80 King Street East
 TORONTO

W. L. STONEBURN
 City Sales Mgr.

Van Auken Twin Screw Motors

NO VIBRATION—Perfectly balanced
NOISELESS—Runs like a dynamo
SIMPLE to run and to install
COMPACT—12 in. x 14 in. high
TWO REVERSE CLUTCHES
TWIN SCREWS—with all their advantages
VALVELESS and free from cams and rods
CLEAN—No spattering oil
FAST
GUARANTEED

We have issued a 60 page illustrated catalog

WRITE FOR IT.

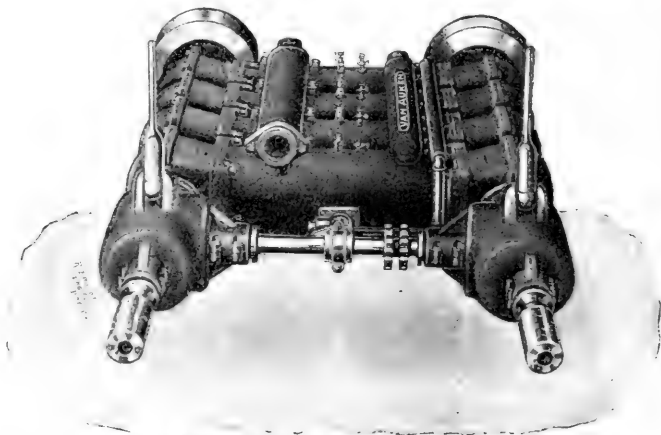

35 AND 65 H. P., 4 CYLINDER

Van Auken Motor and Machine Works
 BRIDGEPORT, CONN., U. S. A.

What the Shooters Demand

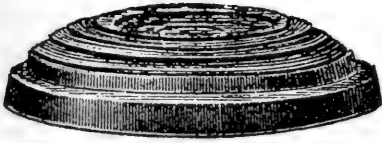

Canadian Black Bird Targets

They break when hit but not before. Manufactured by us and used by most important clubs. Get quotations. "Special prices in quantity."

A Complete Stock

TRAP SHOOTERS SUPPLIES, GUNS, RIFLES, REVOLVERS, AMMUNITION, WINTER ATHLETIC AND SPORTING GOODS, LACROSSE, CRICKET, TENNIS AND FISHING TACKLE

Expert Gun Repairing

A. FENN & CO.

TORONTO

Telephone M 2895

101 King St. West

MOTOR BOAT and AUTOMOBILE

Insurance

We issue all the latest and best forms of policies.

Motor Boats insured against fire and marine perils, while running and while laid up for the winter.

Automobiles insured against fire, explosion, theft, the risks of transportation and damage done and received in collision.

Write us for further particulars and rates

Dale & Company, Ltd.

INSURANCE UNDERWRITERS

Room 20, Coristine Bldg., Montreal, Canada

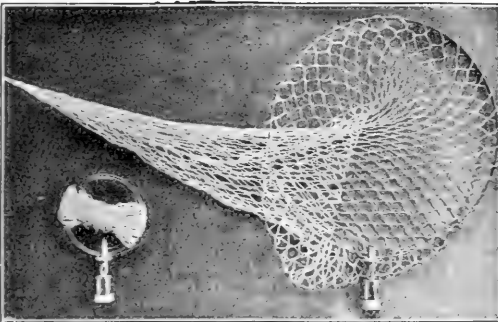

The Anglers' Friend

A Pocket Take Down Landing Net

Compactness, only think, carried in the pocket. No handle to lug, you can fit a handle from any old stick in a few moments. It is unbreakable, and being made of brass cannot rust. It can be reduced to any size from 12 to 4 inches.

Price \$2 00—Money Back if Not Satisfactory

Smith Bros. 1011 Dorchester Avenue
BOSTON, MASS.

WHEN "SNAGGED"—DON'T PULL

break and lose several feet of line, and experience the inconvenience of refitting your line with hooks, sinkers, etc.

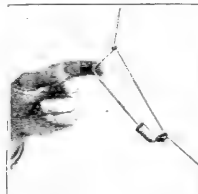

Prevent this loss of valuable time by using

Immell's Snagged Hook Releaser.

It positively releases snagged hooks. No extra line required—Simply place the releaser on your line and let it go, it comes back to you with the hook. Can be carried in vest pocket.

Price:

Trout and Bass size 25c.
Pike and Pickerel size 35c

IMMELL MFG. CO. BLAIR, WIS.

For TWO Subscriptions

we will send an

Ideal Hunter's Axe

with leather sheath, which can be attached to waist belt, manufactured by **H. WALTERS & SON**, the celebrated Axe manufacturers, Hull, Que.

"Hiawatha Camp Hotel"

Kensington Point, Desbarats, Ontario

Exquisite situation; air, water, site unexcelled; good fishing, canoeing and camping; good society. Reference:

Tourist Dept.,

Canadian Pacific Railway,

MONTREAL

From 18 to 50 horse-power—from \$1,500 to \$4,500. Runabout, roadster or touring car, whatever your choice you can satisfy with a

RUSSELL



RUSSELL models vary in size, power and price, but never in quality. The same high grade construction identifies them all—each is the best car of its type possible to build—each must uphold the RUSSELL reputation.

Even the lowest priced cars we produce have such standard features as selective transmission, shaft-drive, metal to-metal clutch, floating type of rear axle, nickel steel driving mechanism, F. & S. ball bearings, and many others

Send for our handsome catalogs.

Canada Cycle and Motor Co., Limited, West Toronto.

Makers of High-Grade Automobiles.

Toronto, Montreal, Hamilton, Ottawa, Vancouver, Winnipeg, Melbourne, Australia



Dunlop Tires Hold Auto

Records

Every Automobile Show is representative—it brings out the most approved and popular cars and automobile tires. At the recent show in Toronto there were 236 automobile tires on the floor, of which

The Dunlop Company Supplied . . . 108 Tires

Five American makers supplied on an average, each . . . 20 Tires

Two Canadian makers supplied on an average, each . . . 14 Tires

Dunlop Tires represented 46% of all the Tires at the Show

It was **THREE to ONE** comparing Dunlop Tires with the showing made by any American maker having tires fitted to cars entered for sale or exhibition.

It was **EIGHT to ONE** comparing Dunlop Tires with any other make of Canadian Tires

The Dunlop Tire & Rubber Goods Company Limited

Dunlop Automobile Tires are Sold by Agents, Automobile Supply Houses and Garagemen Everywhere in Canada



THIS BOAT FOLDS INTO A PACKAGE.

It's Solid and Stiff when in use—collapsible and quickly made portable. Carried by hand or in a buggy. Tempered, galvanized, light steel ribs give both strength and lightness. Is a revelation in boat construction. Non-sinkable. Puncture proof. No repairs. No cost for storage. Wears longer than a wooden boat. We make all sizes and styles for every purpose. Our catalogue—100 engravings—sent on receipt of 6 cents.

KING FOLDING CANVAS BOAT CO.

465 Lake St., Muskegon, Mich.,
formerly Kalamazoo.

Search Lights

ACETYLENE
FOR LAUNCHES AND
MOTOR BOATS



Including
Generator
\$12.00

Starboard, Port
and Mast Head
Lights. Marine
lamps of all kinds.
REPAIRING
Auto Lights a
specialty.

Mangin Mirror
Lenses, all sizes,
in stock.

Write for catalogue describing other styles in
brass and other finishes.

THE HIRAM L. PIPER Co., Limited

17 to 23 Normond St., MONTREAL

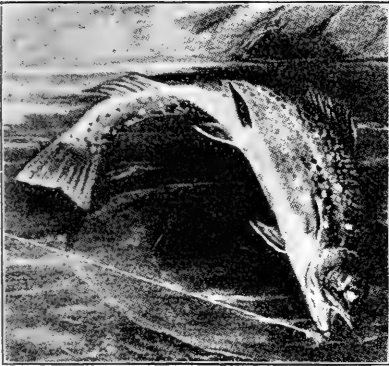

Patent Waxed Lines

Guaranteed not to absorb water,
Superior Line for Casting.

- Size 0, 2½ cents per yard.
- Size ½, 2¾ cents per yard.
- Size 1, 3 cents per yard.
- Size 2, 3½ cents per yard.

Casting Line—Size 00, 1½ cents per yard.

Put up on cards, 25, 50, 75 and 100 yards continuous lengths.

A. E. BREGENT,

192 St. Catherine St. E., Montreal

Corticelli

Silk Fish Line

Made on latest im-
proved machinery.
Absolutely pure,
strength guaranteed,
the strongest and
lightest line made.

IN 4 COLORS—

White with Black.
Black with Olive.

Black with White.
Black with Brown.

- Size 0, 1½c per yard.
- Size ½, 1¾c per yard.
- Size 1, 2c per yard.

- Size 2, 2½c per yard.
- Size 3, 3c per yard.
- Size 4, 3¾c per yard.

Enamelled Lines

Not a union line, but the best silk.
ENAMELLED BY HAND.

- Size ½, 3¾ cents per yard.
- Size 1, 4 cents per yard.
- Size 2, 4½ cents per yard.
- Size 3, 5 cents per yard.
- Size 4, 5¾ cents per yard.

Size 0, 1½ cents per yard.

For Sale By

ART ROSS & CO.,

474 St. Catherine St. W., Montreal

WANTED

SUITABLE ARTICLES

FOR PUBLICATION IN THE

MOTOR MAGAZINE of Canada

Descriptions with or without Photographs of Runs in any part of Canada; Stories of Motor Boat Trips; Descriptions of Tours; Write-ups of Clubs; and Photos of Club Houses.

Personal Experiences of Motoring on Land or Water.

Suggestions and Queries of all kinds solicited.

Motoring for Pleasure, Profit and Business is growing in Canada at a great rate and the people want to know about it. The Land of Waterways provides the finest scenes for motoring on water to be found in any part of the world.

The scenic beauties of the Dominion can be best enjoyed on motoring tours.

The present year will be a great motoring year.

Send all manuscript and photos to

W. J. TAYLOR, Publisher

THE MOTOR MAGAZINE OF CANADA

5 KING STREET WEST

::

::

::

::

::

TORONTO

Special Offers in Guns and Ammunition

- One new No. 4 Ithaca 12 guage gun, Damascus barrels, list \$100, special sale price. **\$65 00**
- One No. 4 Ithaca, 12 guage, Krupp barrels, list \$100, special price **\$70.00**
- One Remington, Trap Ejector grade, 12 guage, special price..... **\$35.00**
- One Clapborough & Johnson 12 guage, Damascus barrels, new, special price..... **\$50 00**
- One Syracuse 12 guage gun, Krupp steel barrels, ejector..... **\$32.50**
- One second hand "H" grade Lefever gun, special price..... **\$27 50**
- 15,000 Sovereign, 12 guage x 2 3/4 in., empty shells, new stock..... **\$6.50 per 1000**
- 10,000 Ely Grand Prix, 13 guage x 2 3/4 in. empty shells..... **\$7.75 per 1000**

Special prices to Clubs on loaded shells.

TRAPS, TARGETS, ETC.

Agents Lefever Guns.

Write us.

EVERYTHING IN CANVAS

THE D. PIKE CO. LIMITED

123 KING ST. E., TORONTO.

WE GUARANTEE to increase the speed of your boat 1 to 3 miles per hour. There are no restrictions nor strings whatever on this proposition.

By years of experimenting we have found that a propeller with blades of a differential pitch and a concave curve from the hub to the outside of blade will hold the water the whole length of blade which lessens the slip more than any other design of wheels, thereby increasing the speed of any launch.

We also make all kinds of bronze" trimmings, stanchions, etc., and fog bells at lowest prices.

BRYANT & BERRY CO.

34 West Atwater St.

Detroit, Mich.

3 in One

is used and recommended by the largest fire-arms manufacturers in America. Experienced gun users everywhere say it is the best rust preventative on earth—on water, too.



Being a light oil it enters the pores of the metal and forms an imperceptible covering that is moisture-proof without making the gun sticky or greasy to handle. Best for oiling the fine mechanisms of the finest gun, because it does not dry out, gum, harden, turn rancid, collect dust.

Free sample. 3 in One Oil Co. New York, N. Y.

AUTO-LAUNCH FOLDING TOPS

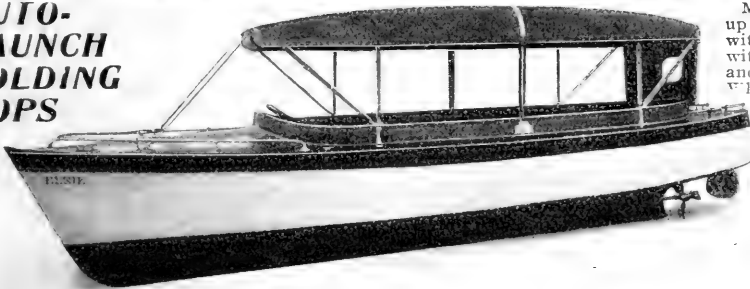

Made to fit any size Motor Boat up to 38 feet long. Side curtains with celluloid lights are furnished with top. Can be made as snug and watertight as any cabin boat. When folded down it is completely out of the way; one half of the top is folded to the bow, the other half to the stern, and lays around the combing. It is staunch, handsome and light, an ornament to any boat. No Motor Boat owner should be without one. Write for circular and prices.

Manufactured only by

The Conboy Carriage Co., Queen Street E. and Don, Toronto, Ontario

PERFECT WASHER

Pat. app. for

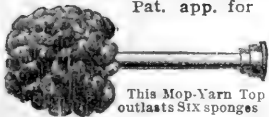

This Mop-Yarn Top outlasts SIX sponges

Price, \$1.75 delivered Extra Top, 50c.

"L. & M."

WE WILL RETURN YOUR MONEY IF NOT SATISFACTORY Order now or send for catalogue

LONG & MANN COMPANY, Rochester, N.Y.

SOLE CANADIAN AGENTS:

GEORGE B. FROST, Smith's Falls, Ont.

Also Agent for "The Little Steersman."

TIRE LOOSENER

Pat. app. for



Loosens rusted or frozen tires from clincher or detachable rims

Price \$3 delivered

THE WONDERFUL "COAXER" TROUT FLY!

ALMOST ALIVE. NEVER LOSES ITS SHAPE. FLOATS ANYWHERE.

"My guide said, 'these trout don't take flies.' I got 24 on the 'Coaxer.' 'I caught a 15-inch brook trout on the 'Coaxer'—that's the record here.' 'I got 17 speckled beauties before breakfast that averaged 12 inches.' 'I have caught over 400 trout on one little 'Coaxer' fly.' 'I found my little boy catching croppies with it to beat the band.'"

Trout Size, 6 colors, \$1.35; 12, \$2.60. Bass Size, 6 colors, \$1.65; 12, \$3.25.



Send Stamp for Booklet of Bass Baits, etc., in colors.

W. J. JAMISON, 1274 POLK ST., CHICAGO.

NEW JAMISON TROUT SPOON

Cut shows size 6.



Set of Four Colors, \$1.00. Made on 2, 4 and 6 hooks.

For Sale, Want, and Exchange Depts.

Advertisements will be inserted in this Department at 2c. a word. Send Stamps with order. Copy should not be later than the 15th of the month.

502 YORK STREET, KENNELS, London, Ontario. Breeder of Deer, Fox and Rabbit Hounds.

SPORTSMEN, come our way for the best hunting and fishing country, on the North Shore of Lake Superior. Moose, Caribou and Bear, numerous; also Trout, Pike, Pickerel, and Bass weighing from 1 to 7 lbs. was caught at our camps last year. Only one day's travel by canoe from the Canadian Pacific Railway. Twenty-four moose seen in twelve days from our camp door in October last year by American sportsmen. We furnish everything. White guides are only employed by us. Write for particulars in regards to our hunting country. Address, Gray and Armstrong, Schreiber, Ontario, Canada, Box 31.

WANTED—Subscriber would pay a reasonable price for a Snow Owl in good condition for purpose of taxidermy. Write stating price expected. W. R. Bishop, London, Ont.

FOR SALE—Old automobile Runabout in good running condition, practically as good as new. —P. O. Box 204, Woodstock, Ont. tf

FOR SALE Speckled Trout Fry at Dr. Robinson's Private Hatchery, Silvercreek, Caledon Township. Address O. J. Walker, Supt., Caldwell, Ont

ARTICLES FOR SALE—Genseng Roots and seeds grow in any shady corner, valuable crops, no expense after planting, write for prices R McGregor and Co., 99 Gladstone Avenue, Toronto.

WRITE ME if you have a canoe for sale. I. C. Savage, Waterford, Ont.—it.

FOR SALE—Large quantity trout fry—very cheap. Caledon Mountain Trout Club, Brantford, Ont.

FOR SALE Good brown motorcycle 2nd hand, 3½ H.P. at a bargain. \$125.00 cash. Apply Box W. Rod and Gun, Woodstock, Ont.

FOR SALE Registered Airedale Terrier Puppies. No fancy prices expected. W. R. Cunningham, Annapolis, Nova Scotia,

SETTER FOR SALE—Bitch, whelped last July, Bilton with some Irish; nicely marked black and white; two dark ears; a hard dog to break but a dandy when trained. Price \$12. Walter Holmes, Clinton, Ont. r t

FOR SALE—Zeiss-Stereo, Marine Glass Binocular, 12 power, fine condition. List price \$85.00, will take \$40.00 for quick sale. Will also sell good Camera with Anastigmat lens; Nelson, 531 Grain Exchange, Winnipeg, Man.

FOR SALE—Large Mounted Moose Elk, Caribou and Deer heads, Fur Rugs of all kinds with Mounted heads, closed or open mouth finish, Tanned skins for robes and hangers. Taxidermists supplies. glass eyes, etc, write for my prices. Edwin Dixon, Expert Taxidermist, Main Street, Unionville, Ontario.

TYPEWRITERS—By buying from us you save 50 to 75 per cent. \$60 to \$125 typewriters rebuilt at \$15 to \$50. State make you prefer. The Typewriter Builders, Hochelaga, P.Q.—it.

FOR SALE a famous hunting ground, house and two hundred acres of land, deeded, good runways and lake in sight of house. Within five miles of Steam Boat Landing. Particulars apply to D. F. Jenkins, Magnetawan, Ont —r-t.

FOR SALE—High-class cocker spaniels, toys, poodles and pomeranians. Puppies and full grown dogs. Apply P. Herd, Belmont Kennels, 21 New St., Toronto.—it.

GASOLINE LAUNCH FOR SALE—New and desirable, thirty foot dory, twenty-two foot cock-pit. Nearing completion. This is an extra good sea boat, with a large carrying capacity. Just the thing for Lake Cruising and bass-fishing parties—would accommodate as high as thirty fishers or one man can run her. Rabbit's patent anchor, one hundred feet of chain; forward and side steering; Canopy top and storm proof curtains. Cabinet closet at stern, good engine by McKeough and Trotter, Chatham, eight miles per hour. Price \$850 or for \$200 extra, will substitute 15 horse power engine giving ten miles per hour. Preparing to build a 25 footer, with hunting cabin. Look me up. Can save you money. S. B. Cook, Long Point Light House, via Pt. Rowan tf

LESSEE, having fine Fishing and Hunting territory in the Laurentian Mountains, would build and furnish a log Camp at one of his lakes for rent to desirable party for the Summer. Speckled trout unlimited, (average ½ lb.) Caribou in the fall. For full particulars address E. C. W., P. O. Box 344, Quebec.

FOR SALE—4,000 feet second hand moving picture film, cheap. E. S. Coppins, Woodstock, Ont. tf

WANTED TO BUY—Unmounted deer heads, elk heads, etc. Send full particulars with desired prices, Northwestern Schol of Taxidermy, Omaha, Nebr. it

RIFLE \$8; Shotgun \$14; Camera \$11; Books, etc., Box 784, Brockville, Ont. it

FOR SALE—26 inch two blade reversible propeller made for Lozier engine. Half Price. H. B. Odell 1051 Eastern Ave., Toronto. it

SECOND HAND ENGINE, six horsepower, complete with reversible propeller, make and break. 1041 Eastern Ave., Toronto. it

FOR SALE—Two cylinder engine, five horsepower jump spark, cost \$190 last year, will sell for \$120; am getting larger engine. R. Perrier, 1041 Eastern Ave., Toronto. it

CHEAP MARINE ENGINES FOR SALE sizes from 3 H.P. up. Ask for circular Sherman Cooper Co., Toronto. it

FOR SALE OR EXCHANGE—1 thoroughbred foxhound trained on deer and fox \$15, or will exchange for Balloon, Silk tent, or what offers. Syd. Jackson, Bala, Muskoka, Ont. tf

1909 Improved KELTSO Automatic Reel

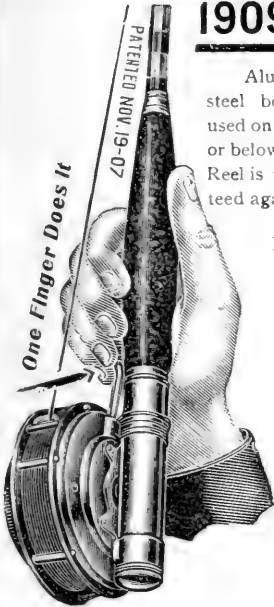

Aluminum casing, steel bearings. Can be used on Rod either above or below the hand. This Reel is positively guaranteed against any defect.

If you once use a **KELSO AUTOMATIC REEL** you never will use any other for fly casting.

JACK FROST'S PATENT FLY BOOK



All flies and leaders, both dry and moistened ready for use in one package. Removable transparent celluloid pockets for Flies, fancy finish Aluminum Box, fitted with fine grade wool felt for moistenings Flies and Leaders, fastened to box by glove button, so the felt can be removed and wet without wetting the Book. Dimensions: 1 inch thick, 5 inches wide, 7 inches long.

- | | |
|---|--|
| No. 1S. Seal Covers, capacity 6 doz.\$3 50 | No. 4P. Pigskin Covers, best finish, capacity 8 doz.\$5 00 |
| No. 2W. Walrus Covers, extra finish, capacity 7 doz.\$4 00 | No. 5A. Alligator covers, best finish capacity 8 doz\$5 00 |

CATALOGUE TO THE TRADE ONLY.

H. J. FROST & CO., 90 Chambers Street NEW YORK



A Wonderful Improvement in Bait Casting Rods

Heddon's Dowagiac Split Bamboo Bait Casting Rod is a two-piece rod which combines the fine resilient action and casting force of a one-piece rod with the carrying convenience of a three-piece rod. Will outlast any other rod made. The cork finger grip and patent locking reel band, shown on the butt joint above, are features of exceptional value.

Free Instruction on Bait Casting.—Heddon's Treatise on the Art of Bait Casting sent free on request. Filled with valuable information on bait casting, beautiful colored illustrations, and a detailed description of the Dowagiac Rod. Tells about the selected bamboo imported direct from the Orient, used exclusively in this rod. Explains why we can make a superior quality rod at inferior rod prices. Write today—right away.

Dept. 18 **JAMES HEDDON & SONS**, Dowagiac, Mich.
Manufacturers of the famous DOWAGIAC MINNOWS—sold all over the country.

Brass Launch Fittings

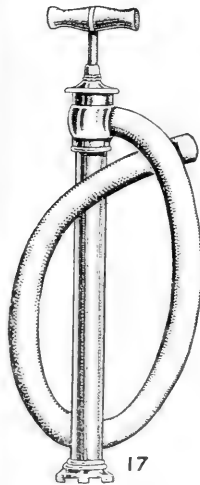

We carry a full line of **BRASS LAUNCH TRIMMINGS** in stock.

Well finished work.

Write for CATALOGUE

Wm. Coulter & Sons

155-7 George St., Toronto.

THE QUEEN'S HOTEL TORONTO.

One of the largest and most comfortable hotels in the Dominion of Canada, and, being adjacent to the Lake, commands a splendid view of Toronto Bay and Lake Ontario. It is well known as one of the coolest houses in summer in Canada, and is elegantly furnished throughout. Rooms en-suite, with bath rooms attached. THE QUEEN'S is furnished with all the latest modern improvements.

Long distance telephone in every room.

McGaw & Winnett
Proprietors.

ROD AND GUN'S ADVERTISERS

Readers who fail to consult our advertising pages miss a large proportion of the most interesting matter in the Magazine. They will find that they may learn much from these announcements.

Every advertisement in ROD AND GUN comes from a responsible firm, and our readers may be assured of courteous answers to all inquiries and good value from all purchases made through these pages.

Automobile Insurance		Cigars	
Dale & Co., Ltd.	43	Harris Harkness Co.	4
Automobiles		Cooked Meats	
Canada Cycle & Motor Co.	44	Fearman's English Breakfast Bacon, Sugar cured Hams, Cooked Meats—W. F. Fear- man	25
Dayton Tonneau Co.	4	Camp Furniture	
Oldsmobile Co. of Canada Ltd.	41	Kiffe, H. H. Co.	15
Reo Motor Car Co.	26	Michie & Co.	56
Tudhope-McIntyre Co.	37	Canadian Railways	
Animal Traps		Grand Trunk Railway System	13
Oneida Community Co.	40	Canadian Pacific Ry.	1110-1111
Ales and Beers		Canoes	
Labatt, John	1105	Chestnut Canoe Co.	53
Automobile Accessories		Capital Boat Works	33
Dunlop Tire & Rubber Goods Co.	44	Dean, Walter	27
Dry Cells Electrical Specialties Ltd.	1118	Gidley, H. E. & Co.	36
Franco-American Auto Co.	17	Kiffe, H. H. Co.	15
Frost, Geo. B.	47	Lakefield—Lakefield Building & Mfg. Co.	1108
National Coil Co.	5	Life Saving Folding Canvas Boat Co.	40
Never Miss Spark Plugs	15	"Peterborough"—Peterborough Canoe Co., Ltd.	29
Sta-Rite—R. E. Hardy Co.	32	Ross, J. H. Canoe Co.	12
Spltdorf, C. F.	40	William English Canoe Co.	36
Vulcan Sparkers—Croftan Storage Battery Co.	7	Clothing	
Ammunition		Clarke, A. R.	27
Du Pont de Nemours Powder Co.	1105	Raino Co.	32
English Schultze—London and Toronto Trad- ing Co.	1109	Turnbull, C. Co.	1092
Shot—Montreal Rolling Mills Co.	1105	Dogs	
Snap-Shot and Carbon Powder—Hamilton Pow- der Co.	5	Glover's Dog Remedies—H. Clay Glover	40
U. M. C.—Union Metallic Cartridge Co.		Fishing Territory	
	Inside back cover	Hiawatha Camp Hotel	43
Winchester Repeating Arms Co.	Inside front cover	Furs	
Batteries		Monteith Strother Fur Co.	1096
Vulcan Sparkers—Croftan Storage Battery Co.	7	Weil Bros.	24
Boots For Sportsmen		Folding Boats	
Palmer John Co.	39	Acme Folding Boat Company	1118
Canadian Guides		King Folding Canvas Boat Co.	45
Dainard, M.	1092	Fishing Tackle	
Campbell, Robt. E.	1092	Allcock, Laight and Westwood Co.	15
Cameras and Kodaks		Bristol Steel Fishing Rod—Horton Mfg. Co.	17
Canadian Kodak Co., Ltd.	38	Cummins, W. J.	1101
Gundlach-Manhattan Optical Co.	5	Corticelli Silk Fish Line	45
Camp Supplies		Coller Rubber Grip Co.	36
Aylmer Condensed Milk Co.	1102	Doering & Co.	39
Ales and Porters—John Labatt	1105	Divine, Fred D.	32
Chiclets	25	Gregory, J. F.	39
Club Cocktails—G F Heublein & Bro.	21	Frost, H. J. Co.	49
Fenn, A. & Co.	43	Friend, S. H.	32
Fearman's English Breakfast Bacon — Sugar Cured Hams, Cooked Meats—W. F. Fearman Co.	25	Hildebrandt, Jno. J. Co.	1099
Kiffe, H. H. Co.	15	Hardy's Rods, Reels & Tackle—Hardy Bros.	19
Michie & Co., Ltd.	56	Hartung Bros. & Co.	21
Marietta Stanley Co.	20	Heddon, Jas. & Son.	49
Marble Safety Axe Co.	29	Immell Mfg. Co.	43
Shredded Wheat Biscuits and Triscuits—Can- adian Shredded Wheat Co., Ltd.	1116	Jamison, W. J.	47
		Smith Bros.	43
		Unkefer & Bradley	33
		Young Carlos G.	1107
		Game Pictures	
		Clapham, R.	17

Guns and Rifles	
Fox, A. H. Gun Co.....	1091
Ithaca Guns—Ithaca Gun Co.....	1095
Kiffe, H. H. Co.....	15
Lancaster, Chas., London.....	39
Lever Guns—Lever Arms Co.....	35
Marlin Rifles—Marlin Firearms Co.....	41
Pike, D. Co.....	47
Parker Guns—Parker Bros.....	22
Ross Rifle Co.....	8
Remington Arms Co.....	Inside back cover
Stevens' Rifles, Pistols, Shotguns, Rifle Telescopes, Guns, etc.....	Outside back cover
Winchester—Winchester Repeating Arms Co.....	Inside front cover
Gun Cabinets	
Kiffe, H. H. Co.....	15
Gun Smith	
Johnston, Alex.....	1120
Gun Sights	
Lyman Gun Sight Corporation.....	36
Hotels	
Clarendon Hotel, Winnipeg Man.....	1099
Hume Hotel, Nelson, B.C.....	9
Queens—Toronto.....	49
Tuller, Detroit—W. A. Shaw, Manager.....	9
Winters—Vancouver, B. C.....	12
Hunting Territory	
Canadian Pacific Ry.....	1110-1111
Liquors	
Club Cocktails—G. F. Heublein & Bro.....	21
Labatt, John.....	1105
Michie & Co., Ltd.....	56
Launches	
Butler, M. L.....	19
Gidley H. E. and Co.....	36
Jutten's Boat & Launch Works.....	56
Peterborough Canoe Co.....	29
Robertson Bros.....	11
Wright, C. T. Co.....	40
Mineral Waters	
Bromo Mineral Water—Bromo Mineral Co.....	7
Medicines	
National Ferrol Co.....	12
Marine Motors	
Adams Launch & Engine Mfg. Co.....	23
Automatic Machine Co.....	2
Beaver Mfg. Co.....	21
Buffalo—Buffalo Gasoline Motor Co.....	34
Brennan Motor Mfg. Co.....	23
Beilfuss Motor Co.....	53
Bryant & Berry.....	47
Caille Perfection Motor Co.....	34
Dunn, Walter E.....	39
DuBrie Motor Co.....	50
Ferro Machine & Foundry Co.....	1
Gray Motor Co.....	33
Gidley, H. E. & Co.....	36
Guarantee Motor Co.....	18
Hildreth Mfg. Co.....	10
Lockwood-Ash Motor Co.....	6
Marine Construction Co.....	37
Schofield-Holden Machine Co.....	16
Syracuse Gas Engine Co.....	22
Sterling Engine Co.....	31
Sintz-Wallin Co.....	1112
Sherman Cooper Co.....	35
Thomas & Grant.....	9
Van Auken Motor and Machine Works.....	42
Wonder Mfg. Co.....	18
Waterman Marine Motor Co.....	14
Magazines	
Field and Stream.....	54
Motor Magazine of Canada.....	46

Miscellaneous	
Beers Bros.....	40
Ideal Carriage Washer Co.....	9
Rundel Sales Co.....	25
Sanitary Pipe Co.....	1120
Safety Air Pump Co.....	18
Talcum Powder—Gerhard Mennen Co.....	9
Motor Boats	
Butler, M. L.....	19
Cowards Boat Factory.....	7
Gidley H. E. and Co.....	36
Robertson Bros.....	11
Ross, J. H., Canoe Co.....	12
Motor Boat Accessories	
Brown Co.....	21
Croftan Storage Battery Co.....	7
Coulter, Wm. & Sons.....	49
Conboy Carriage Co.....	47
Dry Cells—Electrical Specialties Ltd.....	1118
Leckie, Jno.....	1098
Michigan Wheel Co.....	31
Piper, Hiram L. Co.....	45
Never Miss Spark Plug Co.....	15
Sta-Rite—R. E. Hardy Co.....	32
Oils, Varnishes, Paints, etc.	
Three-in-One Oil Co.....	47
Office Appliances	
Conklin Pen Co.....	1093
Smith Premier Typewriters—National Typewriter Co.....	55
Outfitters	
Gold Medal Camp Furniture Co.....	56
Kiffe, H. H. Co.....	15
Michie & Co.....	56
Premiums	
Page.....	52-53
Photo Supplies	
Canadian Kodak Co. Ltd.....	38
National Drug and Chemical Co.....	28
Ward & Co.....	3
Phonographs	
Toronto Phonograph Co.....	30
Prize Trophies	
Bailey, Jas. D., Ltd.....	1120
Physical Culture	
Dorchester, F. E.....	3
Rifle Sights and Gun Implements	
Marble Safety Axe Co.....	29
Revolvers	
Iver Johnson's Arms & Cycle Works.....	1089
Row Boats	
Gidley H. E. and Co.....	36
Lakefield Canoe Bldg. and Mfg. Co.....	1108
Peterborough Canoe Co.....	29
Rust Preventative	
Three in One Oil Co.....	47
Sanitary Mattress	
Marshall Sanitary Mattress Co.....	25
Taxidermy	
Darbey, E. W.....	7
Emack Bros.....	3
Trap-Shooter's Supplies	
Fenn, A. & Co.....	43
Kiffe, H. H. Co.....	15
Want Advertisements	
Page.....	48

Premiums for Sportsmen

To all our subscribers, young and old, these premium offers are open. Our premiums, comprising practically everything in the sporting goods line, from a fish hook to an automobile, can be obtained FREE by securing subscriptions to the magazine. There are thousands of sportsmen who have never seen ROD AND GUN who would willingly subscribe if they were shown a copy.

If you see what you want in the following list, write and we will tell you how many subscriptions it will be necessary to secure in order to earn it. We will furnish sample copies for canvassing purposes and do all in our power to assist in making your canvassing campaign a success.

Write to-day for particulars to Premium Dept., ROD AND GUN IN CANADA, Woodstock, Ont.

No premium is given on subscription a man sends in for himself. No premium is given for a renewal subscription.

For One Subscription

We will send :

- A Shield Brand Pipe;
- A McCurdy Frog Harness Hook manufactured by B. F. McCurdy, Chicago;
- A Pflueger single action Flush Handle Reel—40 yards, polished nickel, Plate-Pillar, 1 inch; dish, 2 inches;
- A Pflueger Phantom spinner—a killing combination for all game fish, painted true to life, non-luminous; a luminous one for two subscriptions;
- A Pflueger round wide pattern quadruple reel, capacity forty or sixty yards, adjustable back, sliding clock and drag, polished nickel plate;
- A Kelso Pearl Spoon bait manufactured by H. J. Frost & Co., 90 Chambers Street, New York.
- A Sullivan Hook and Reel Guard manufactured by Chas. L. Sullivan, 617 Railway Exchange Bldg., Chicago.
- A Crow Call, manufactured by Chas. H. Perdew, Sr., Henry, Ill., made from Red Cedar, with German Silver Reed and Band, handsomely polished. Guaranteed to give satisfaction.
- A 60 yard Fishing Reel, burnished ;
- A quart tin of "Standard" Dog Wash
- A Matchless Cigar Lighter. Lights cigar, cigarette and pipe anywhere at any time—in wind, rain or snow;

For Two Subscriptions

We Will Send a Sta-Rite Spark Plug manufactured by the R. E. Hardy

Co., New York. Every Motor Boat owner is interested in these plugs. We have only a limited number to distribute.

A Never Miss Spark Plug, manufactured by the Never Miss Spark Plug Co., Lansing, Mich.

A Splitdorf Common Sense Plug, manufactured by C. F. Splitdorf, 1679 Broadway, New York.

A Sanitary Pipe, manufactured by the Sanitary Pipe Co., 125 Cutler Building, Rochester, N. Y.

An Elite Single Minnow Pail, (8 quart) ;

A copy of the complete Sportsman's Guide by Buzzacott;

A copy of Deadfalls and Snares; a book of instruction for Trappers about these and other home-made Traps;

A copy of Canadian Wilds; tells about the Hudson's Bay Company, Northern Indians and their modes of Hunting, Trapping, etc.

A copy of Steel Traps; describes the curious makes and tells how to use them, also chapters on care of pelts;

A copy of the Amateur Trainer, by Ed. F. Haberlein;

A copy of Practical Dog Education by Abbott;

or A copy of Fox Trapping, a book of instruction, telling how to trap, snare poison, shoot, a valuable book for trap pers; A copy of Mink Trapping, a book instruction giving many methods of trapping, a valuable book for trappers. (We will send a copy of each of these

books for four subscriptions.) These books are edited by A. R. Harding, nicely illustrated and contain 200 pages.

A Stag Brand Landing Ring manufactured by Allcock, Laight & Westwood, Toronto;

A K. W. Spark Plug made by K. W. Ignition Co., Cleveland, Ohio;

A Kent Double Spinner bass bait made by Samuel H. Friend, Kent, Ohio:

A Gem Carlton Reel;

Anti-Cussin Fish Hook Holder made by Sportsman's Specialty Co., Chicago.

The Anti-Cussin Hook Holder keeps hooks and snells in perfect order.

A round Plate Nickel and Rubber Clicd Reel made by Wm. Mills & Son, New York.

For Three Subscriptions.

We will send :

Three Crow Decoys, manufactured by Chas. H. Perdew, Sr., Henry, Ill.

One-half dozen stag Brand Rubber Frogs or Froggies.



**Sit on the Edge—it Cannot Upset;
Fill it With Water—it Cannot Sink**

Patent Air Chambers on sides of Chestnut Sponson Canoe, like life boats, prevents it from upsetting. Sit on its side—it won't upset; fill it with water—it cannot sink. Air Chambers are built on outside of

The entire framework is covered with one seamless sheet of Chestnut specially-woven Canvas. This Canvas is thoroughly coated with a special preparation, which fills up every pore in the Canvas, and dries

Chestnut Sponson Canoe

Canoe, do not touch water, and therefore do not interfere with speed.

Chestnut Sponson Canoes are far lighter than any other Canoe of equal size—speedy, easy to paddle, comfortable and safe—an ideal pleasure craft.

The lining and wide ribs are staunchly made of finest perfect Cedar. Ribs are placed closely together, insuring enormous strength.

Chestnut Canoe Co., Ltd.,

as hard as flint. No fear of leakage—weather variations cannot effect it. It cannot crack, cake or dry out. Chestnut Sponson or Pleasure Canoes are smoothly and handsomely finished. Plenty of room, comfort, speed and cleanliness.

FREE—Our handsomely illustrated descriptive Booklet shows many models—it's free—drop us a card by next mail.

Fredericton, N.B., Box 445

AUTO BOAT AND AUTO MOTORS

10-12 H.P.
18-20 H.P.

Four Cycle
Double Cylinder

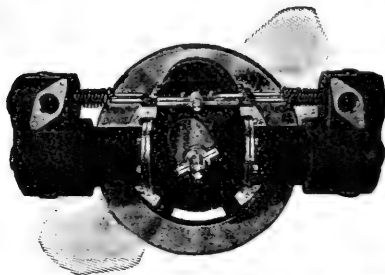

Agents Wanted.

Satisfaction
Guaranteed.

Send for Prices and
Circulars.

THE BEILFUSS MOTOR CO., LANSING, MICH., U.S.A.

When writing Advertisers kindly mention Rod and Gun in Canada.

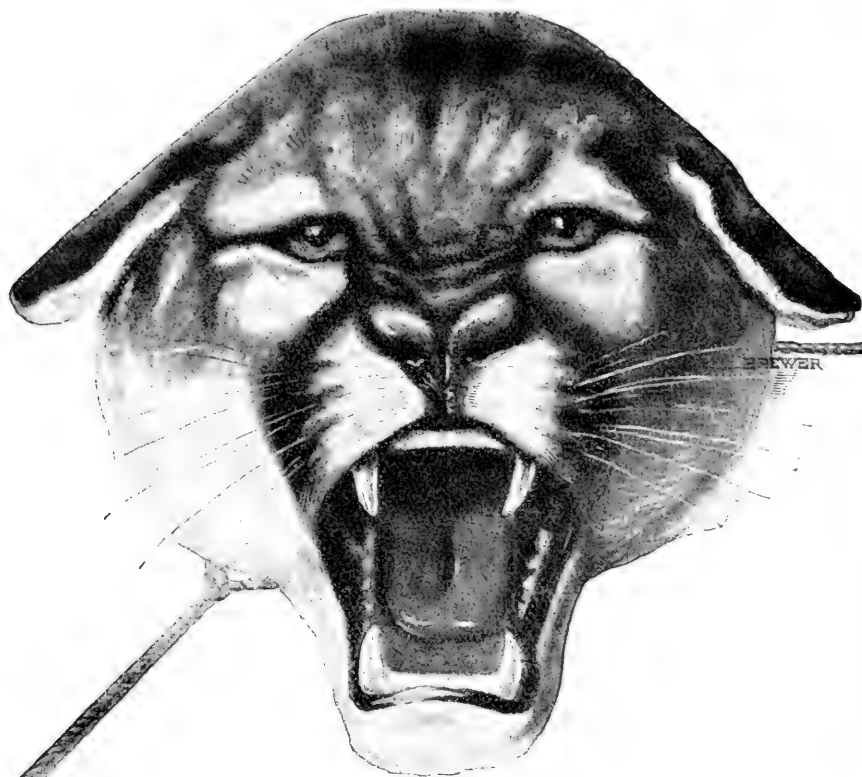

Roping Lions in the Grand Canon

BY ZANE GREY

Author of "THE LAST OF THE PLAINSMEN"

☐ Buffalo Jones is the only man who ever lassoed lions. Zane Grey is the only writer who ever had opportunity to describe this new, wild and thrilling sport. The story of their second expedition, of adventure almost surpassing belief, illustrated by photographs that tell the truth, and full of the wonder, the mystery, the color of the Grand Canon, will grip the heart of every sportsman and lover of the wilds.

Commencing serially in the January issue of

FIELD AND STREAM

For the man who is interested in feathered game, big game, trap shooting, fishing, camping, canoeing or adventure, FIELD AND STREAM is the American Magazine for sportsmen.²

A publication that will appeal to you if you love the great outdoors and its sports, as nearly perfect as it can be made by publishers, editors, writers, artists and photographers, who are one and all sportsmen.

SPECIAL OFFER—To get the magazine in the hands of new readers, we will send the numbers containing the first three installments of Zane Grey's story for thirty-five cents including Canadian Postage.

FIELD AND STREAM PUBLISHING CO.

30 West 21st Street, New York.



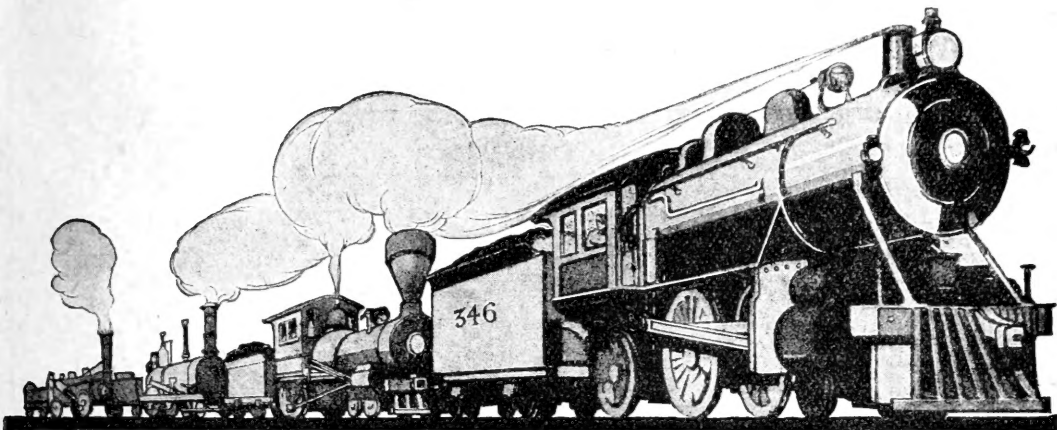

Every change in the
Smith Premier
Typewriter

is an added advantage.
 All of the good original
 features are retained.

The name "Smith Premier"
 stands for all the good that can
 be put into a typewriter.



THE SMITH PREMIER TYPEWRITER CO.
[INCORPORATED]
 Syracuse, N. Y., U. S. A. Branches Everywhere.

The National Typewriter Co., Ltd.
 78 Victoria Street, Toronto, Ont.

WE OUTFIT CAMPING PARTIES

Provisions, Tents, Utensils, Blankets, Etc.

MICHIE & CO. LTD.

ESTABLISHED 1835.

7 KING STREET WEST, TORONTO.

G TRADE MARK **M** **This Trade Mark on Camp Furniture Protects You**

As there are some cheap imitations of Gold Medal Camp Furniture, we are forced to take extra precautions to protect the buyers of such goods as well as to defend our own reputation.

Genuine Gold Medal Camp Furniture bears the above trade mark on every article. Every article so marked is backed by an absolute guarantee to wear and withstand any reasonable amount of the rough usage of the camp. We will replace, free of charge, any piece or part that gives way on account of weakness of material or fastenings or faulty construction.

To save annoyance in camp, get the furniture with our name and the Gold Medal trade mark.

Ask for our Catalog. It is FREE.

We still have a few Hunter's Guides and Camper's Manuals. They are 10 cents each while they last.



Gold Medal Camp Stool

Gold Medal Camp Furniture Mfg. Co.



Gold Medal Cot, open and closed.

RACINE, 214 ST. PAUL AVE., WISCONSIN

DuBRIE MARINE MOTORS

Catalogue on Request

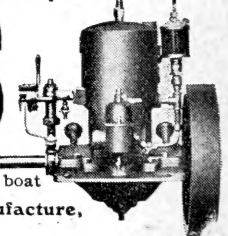

Our GASOLINE MOTORS are made in ten sizes, 2½ to 27 H.P., 1, 2, and 3 cylinder. They have demonstrated their fitness and superiority for every type of hull—speed, pleasure or work boat.

The secret of this is their correct harmonious design, scientific and perfect manufacture, thorough testing, and best equipment.

This motor is made on the theory that nothing but the best can meet the requirements of present day demands. The price is reasonable too.

DuBRIE MOTOR CO.,

430 Guoin Street,

DETROIT, MICH.

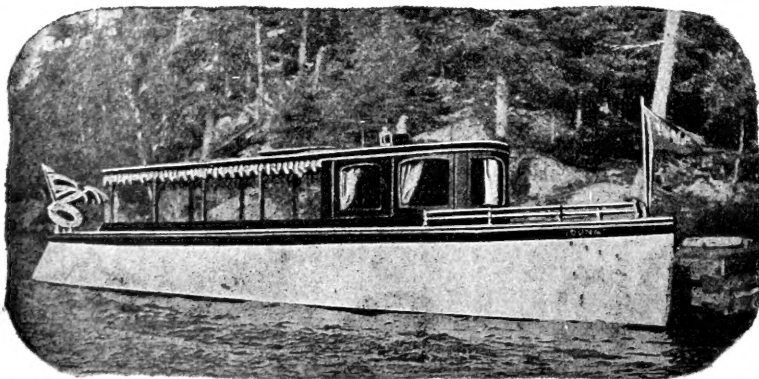

Did you get one of our 1908 Catalogues of Launches and Row Boats?

It will convince you that we build the best and use an engine that will give you no trouble.

JUTTEN'S BOAT AND LAUNCH WORKS. Hamilton, Ont.

The
RED BALL

TRADE MARK
on a box of
SHOT SHELLS
means
**PERFECT
AMMUNITION**

UMC

TRADE MARK REGISTERED IN U.S. PAT. OFF.



The World's Standard Ammunition

Look for the red U.M.C. trade-mark on shot shell boxes. It represents highest quality and stands as a mark of merit. It protects you against inferior and "just as good shells." Memorize this U.M.C. trade-mark. Call for U.M.C. shells and you'll have uniform, snappy, hard-hitting loads.

Insist—it's worth while

THE UNION METALLIC CARTRIDGE COMPANY, Bridgeport, Conn.

Agency

313 Broadway

New York

The New Remington Repeating Shotgun



3 Remington Features

"Solid Breech, Hammerless, Bottom Ejection"

Single barrel guns are popular,—easy to handle and aim. The Pump action is also popularized. But remember, the Remington Pump is 3 steps in the lead: 1st, Hammerless; 2nd, **SOLID BREECH**; 3rd, Loads and Ejects at the bottom. No other Pump Gun on the market has even one of these perfected features. The Remington Pump is in a class by itself. We don't compare it to any other. You won't after you examine one.

Get acquainted with the Remington Idea!

Folder and catalogue for the asking.

REMINGTON ARMS COMPANY

ILION, N. Y.

Agency

313 Broadway

New York

New Stevens Double Barrel Shot-guns Fitted with Stevens Compressed Forged Steel Barrels Demi-Bloc System

Note illustrations for clear exposition of principles governing the manufacture of new **STEVENS DOUBLE GUNS**

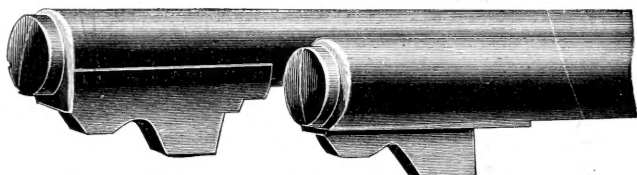

Stevens Compressed Forged Steel Barrels—
Demi-Bloc System

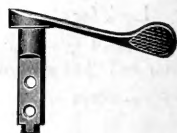

Solid Top
Snap



New Style Fore-end

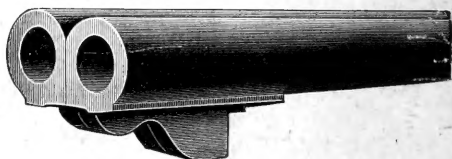

Barrels ready to braze

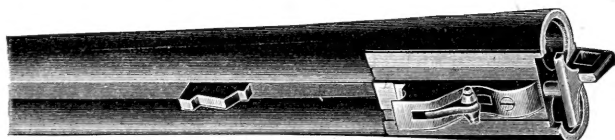

Showing Check Hook

Send 2c Stamp
for new Shot-
gun catalog

Ask your dealer
insist on Stevens
Demi-Bloc Guns

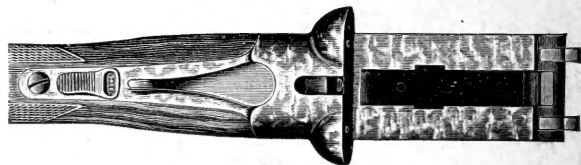

Showing Rotary Compensating Bolt and
Check Hook Slot

J. STEVENS ARMS & TOOL CO.
365 MAIN STREET
CHICOPEE FALLS, MASS.