





262 - 207 complete  
70th London  
172772

# NATURE

A WEEKLY

ILLUSTRATED JOURNAL OF SCIENCE

VOLUME XI.

NOVEMBER 1874 to APRIL 1875

24

---

*"To the solid ground  
Of Nature trusts the mind which builds for aye."*—WORDSWORTH

---

London and New York:  
MACMILLAN AND CO.

1875



LONDON  
R. CLAY, SONS, AND TAYLOR, PRINTERS  
BREAD STREET HILL



# INDEX.

- Abbott (C. C.), American Stone Implements, 190, 215; Habits of the Belted Kingfisher, 227
- Abel (Prof. F. A., F.R.S.), Accidental Explosions, 436, 477
- Aberdeen University, 413, 457
- Acar mounted for the Microscope, 406
- Acclimatisation: Paris, New Zealand, Cape of Good Hope, 77, 98; of Plants, 135, 174; of Salmon, in Otago, 209
- Acoustic Reversibility, Prof. Tyndall on, 239
- Adams (Prof. A. Leith), Fossil Remains of Fallow Deer in Malta, 247
- "Aerial World," by G. Hartwig, M.D., 385
- Aeronautics (*See* Balloons)
- Africa: Explorations in, 116, 195, 293, 356, 457, 496; by Dr. Lenz, 475; Livingstone's "Last Journals," 142, 182; Lieut. Cameron's Expedition, 153; Mr. H. M. Stanley's Expedition, 153; Capt. Gordon's Expedition, 435; Progress in, 435
- Agassiz (Prof. A.), Embryology of the Ctenophora, 76
- Agassiz Memorial Fund, 413
- Agricultural Education, 104
- Agricultural Society and the Potato Disease, 67, 109, 128
- Agriculture in Victoria, 361
- Allport (Samuel), Geology and the Arctic Expedition, 268
- Aloes (Tree) of South Africa, 89, 254
- Alpha Fibre (Esparto Grass), 333
- Alpine Club Map of Switzerland, 8
- "Amazon and Madeira Rivers," by Franz Keller, 241, 262
- America: Bancroft's "Native Races of the Pacific States," 442; Academy of Arts and Sciences, 203; Survey of Colorado, 154; of Texas, 155; and Anderson School of Natural History, 167; Natural Phenomena in, 329, 386; Scientific Survey, 381; Temperature Chart, 267
- American Society, Paris, 135
- Amphibia, Development of the Columella Auris in, 68
- Amú Expedition, 29
- Amú Darya River, Cause of the Change of its Course, 229
- Anabas scandens*, or Climbing Perch, 109
- Anatomy, *Journal of*, 257
- "Anatomy, Human," by W. Turner, M.D., 464
- Ancient Monuments Bill, 481
- Anderson School of Natural History (U.S.), 167
- Anderson (Prof. Thos.), Obituary Notice of, 35
- Angell (J.), "Elements of Animal Physiology," 185
- Animal Kingdom, Classification of, the 101
- "Animal Physiology," by J. Angell, 185
- "Animal Physiology," by J. Cleland, M.D., F.R.S., 504
- Antares, as a Double Star, 249, 274, 287, 405; Occultation of, 308
- "Anthropological Contributions," by George Gerland, 384
- Anthem's Star, 407
- Anthropological Institute, 60, 99, 139, 199, 239, 278, 379, 398, 459
- Anthropological Society, Paris, 98; Munich, 496
- Anthropology, Notes and Queries on, 226
- "Ants, Harvesting," by J. T. Moggridge, F.L.S., 245]
- Ants and Bees, 306
- Aquaria: Utilisation of, 87; Manchester, 36; Hastings, 216; Southport, Westminster, Plymouth, Edinburgh, Scarborough, Birmingham, 393, 396, 427
- Arctic Exploration: Dr. Petermann on, 37; English Arctic Expedition, 16, 55, 61, 75, 85, 87, 114, 134, 153, 173, 235, 253, 293, 348, 355, 372, 474; German Arctic Expedition of 1869-70, 63; Austro-Hungarian Expedition of 1872-74, 366, 396, 415; Geology, 268, 447, 497, 492, 508; Meteorology, 434, 467; Vegetation, 433
- Argelander (Prof. F. W. A.), Obituary Notice of, 332
- Argentine Republic, Science in the, 253
- Ascherson (Dr.), Vegetation of the Libyan Desert, 137
- Ashe (W. Percy), Kirkes' Physiology, 227, 303
- "Assyrian Discoveries," by Geo. Smith, 441
- Astronomy: *Our Astronomical Column*, 228, 249, 269, 286, 308, 348, 365, 387, 407, 428, 446, 472, 489, 507; Brinkley's "Astronomy," by Stubbs and Brünnow, 83; Drayson's "Proper Motion of the Fixed Stars," 66
- Atlantic Notes, 234, 290, 312
- Atmosphere, Upper Currents of the, 457
- Atomic Weights, Dalton's Table of, 52
- Attraction and Repulsion arising from Radiation, 494
- Aurora, Geographical Distribution of, 14
- Austro-Hungarian North Polar Expedition, 396, 415
- Australia: Exploration in, 93; Flora of, 254 (*See* Sydney, Victoria)
- Baker (Sir Samuel W., Pacha, F.R.S.), "Ismailia," 24
- Baldwin (Prof. Thos.), Agricultural Education, 104
- Balfour (F. M., B.A., and M. Foster, B.A.), "Elements of Embryology," 126
- Balloons: Siege (French), 76; Ascent from Paris, 429; Experimental in America, 456; Fatal Ascent of the *Zenith*, 495, 513
- Bamboo Poison, 18
- Banbury, Science at, 310
- Bancroft (H. H.), "Native Races of the Pacific States," 442
- Barometer, Chameleon, 307, 365
- Barrett (Prof. W. F.), Sensitive Flames, 129; Morse Code, 328
- Basilik*, H. M. S., Survey of Coast Lines, 134
- Baynes (Prof. S.), "Encyclopedia Britannica," 343
- Beaumont (Elie de), Obituary Notice of, 41
- Beavers imported to the Isle of Bute, 216
- Beccari (Dr. O.), Discoveries in Herpetology, 447
- Becker (C. L. C.), Obituary Notice of, 455
- Becquerel (M.), Solar Physics, 132
- Bee, Tailor, 476
- Bees and Ants, Sir J. Lubbock, Bart., F.R.S., on, 159, 306'
- Bees and Flowers, 248, 285
- Beetroot Cultivation, 314, 395
- Belfast Natural History Society, 155
- Belgium; Horticulture, 154; Royal Academy of Sciences, 398; Roman Tombs, 435; Temperature of Brussels, 444
- Bellot (Lieut.), Volunteer for the Arctic Expedition, 173
- Bennett (Alfred W.), Flowering of the Hazel, 466
- Berlin: Academy of Sciences, 114; German Chemical Society, 200, 240
- Besmer* Steamer, 342
- Bettany (G. T., B.A.), Practical Science at Cambridge, 131
- Bidie (G.), Suicide of Scorpions, 29, 47
- Biology, Results of the *Polaris* Expedition, 134
- Bird (Isabella J.), "The Hawaiian Archipelago," 322; Volcanic Action in the Sandwich Islands, 386
- "Birds of Europe," by H. E. Dresser, F.Z.S., 485
- "Birds of Northumberland and Durham," by John Hancock, 281
- "Birds of Shetland," by H. L. Saxby, M.D., 81
- Birds: Flight of, 364; Migration of, 5, 135, 149, 234; Birds of Borneo, 407; Bird of Paradise, New, 208; Birds of Paradise in New Guinea, 248; Birds of Utah, 136
- Birmingham and Midland Institute; Address by Sir John Lubbock, Bart., F.R.S., 21; Natural History Society, 274; College of Science, 331
- Black (Dr. J. W.), Columnar Formation in Mud Banks, 285; Ocean Waves, 444
- Blackbird, Ring, 187, 209, 228
- Blake (Rev. J. F.), Sub-Walden Exploration, 267



- Blanford (H. F.), Report on Indian Meteorology, 145; Mud Banks on Malabar Coast, 187  
 Blind Fish of the Mammoth Cave, 256  
 Blood Louse, 394  
 Boiling Lake in Dominica, 475  
 Boldo, a new tonic medicine, 36, 414  
 Bon (Dr. Gustave le), "La Vie," 246  
 Bonney (Rev. T. G.), Ice Caves, 327  
 Borneo, Birds of, 497  
 Borrelly's Comet, 115, 229  
 Boston (U.S.): Society of Natural History, 80, 180, 273; Academy of Natural Sciences, 419  
 Botany: Botanical Locality Record Club, 175; "Botanical Problems," by Prof. Cohn, 261; *Botanical Magazine*, 317; "Botany for Home and School Use," by Frances A. Kitchener, 147; Botany in Queensland, 271; "Botany, Lessons in Elementary," 226; "Botany, Manual of," by R. Brown, M.A., Ph.D., 345; Botany of Galway Bay, 395; Botany, Systematic, Mr. Bentham on, 254  
 Boltmore (J. T., M.A.), Logarithmic and Trigonometrical Tables, 424  
 Boxwood, 254  
 Brady (H.P., F.L.S.), Flückiger and Hanbury's "Pharmacographia," 42  
 Bramwell (F. J., F.R.S.), Protection for Inventions, 141  
 Brazil (Emperor of), elected Member of the French Academy of Sciences, 356  
 Brazil, Observatory at Rio Janeiro, 395  
 Bright Colour in Animals, 148, 208  
 Brinckley's "Astronomy," by Stubbs and Brünnow, 83  
 British Museum, its Sanitary Condition, 174  
 Brooke (Victor), Fallow Deer in England in Pleistocene Times, 210  
 Brown (Robt., M.A.), "The Races of Mankind," 128; "Manual of Botany," 345  
 Brunton (T. Lauder, F.R.S.), Indian Venomous Snakes, 377  
 Buchan (Alex.), Climate of Scotland, 329  
 Buchanan (Andrew, M.D.), "Circulation of the Blood," 184  
 Buchanan (J. Y.), Vertical Distribution of Temperature in the Ocean, 157  
 Burnham (S. W.), Antares, 495  
 Butter, Artificial, 76  
 Calcutta, Botanic Gardens, 18, 295  
 Cambridge: Science at, 17, 34, 35, 57, 92, 115, 131, 135, 196, 272, 294, 313, 333, 353, 373, 394, 413, 434, 474, 475, 515; Philosophical Society, 140, 339, 400  
 Camels reared in Nevada (U.S.), 396  
 Cameron (Lieut.), his African Expedition, 153, 195; Map of Lake Tanganyika, 293  
 Campbell (Dr. A.), Obituary Notice of, 56  
 Camphor, Distillation of, 456  
 Canada: Geological Discovery, 57; Science in, 414  
 Canada Rice, a new Material for Paper, 33  
 Caoutchouc, Cultivation of, 355, 395, 436  
 Carbon Cells and Plates for Galvanic Batteries, 8  
 Carnuba Root, 414  
 Carpenter (W. B., M.D., F.R.S.), "The Microscope and its Revelations," 283; Soundings taken by H.M.S. *Challenger*, 297  
 Carrier Pigeons, 237  
 Carter (H. J.), Calcareous and Siliceous Remains in Marine Strata, 186  
 Case (F.), Softening of Iron Pyrites, 248, 269, 285  
 "Cave Hunting," by W. Boyd Dawkins, F.R.S., 302  
 Caves of Kentucky, 414  
 Caves, Settle, 304, 514  
 Cedar, Florida, acclimatised in Bavaria, 396  
 Ceylon, Forests of, 274  
*Challenger*, Progress of the, 34, 57, 174, 177, 196; Notes by Prof. C. Wyville Thomson, F.R.S., 95, 116, 287  
 Chameleon Barometer, 397, 365  
 Chamois Shooting, 435  
 Chappell (W., F.S.A.), "History of Music," 123, 208  
 Chemical Dictionary, by Dr. H. v. Fehling, 165  
 Chemistry: Chemical Society, 34, 39, 78, 97, 119, 159, 239, 299, 336, 357, 379, 394, 416, 458, 500; Chemistry, Lectures by Prof. Frankland, 497; "Chemistry, Physiological, Demonstrations on," by S. W. Moore, F.R.S., 283; "Chemistry, Practical," by Frank Clowes, B.Sc., 107; Chemistry of Cremation, 33  
 Chesil Bank, Origin of the, 386, 506  
 Chester, Society of Natural Science, 322  
 Chicago, Botanical Gardens at, 294  
 China, Expedition from Burmah through, 175, 209  
 "Chinchon, Memoir of the Countess of," by C. R. Markham, C.B., F.R.S., 383  
 Chinese Dwarf Trees, 475  
 Chinese Grass Plant, 315  
 Chisholm (H. W.), International Metric Commission, 54; his Annual Report as Warden of the Standards, 270  
 Cholera, Microscopical Researches on, 444  
 Cinchona Bark, Trade in, 373  
 Civil Engineers' Institute, 79, 174, 196, 240, 299, 246, 339, 459, 480  
 "Civilisation, Origin of," by Sir J. Lubbock, Bart., M.P., F.R.S., 401  
 Classification of the Animal Kingdom, 101  
 Cleland (John, M.D., F.R.S.), "Animal Physiology," 504  
 Clerk-Maxwell (Prof., F.R.S.), Dynamical Evidence of the Molecular Constitution of Bodies, 357, 374  
 Clock Movement, Inventor of its application to Equatorial Telescopes, 166  
 Clock, New Standard Sidereal, at the Royal Observatory, Greenwich, 431  
 Clothworkers' Company, Science Exhibitions at Cambridge, 34, 456  
 Clowes (Frank, B.Sc.), "Practical Chemistry," 107  
 Coal in New South Wales, 136; American, 36  
 Coal Ashes, Diatomacæ in, 475  
 Cobbold (Dr. T. S., F.R.S.), Lewis on Hæmatozoa, 363  
 Cocoa Cultivation, 216  
 Colometer, the, 17  
 Coffee Plant, Disease in the, 475  
 Coggia's Comet, 238, 295  
 Cohn (Prof.), "Botanical Problems," 261  
 Colorado Beetle, 355, 476  
 Colorado, Survey of, 154  
 Cold, its effects on Railway Axles, 195  
 Cole (Sir Henry, K.C.B.), appointed Commander of the Bath, 412  
 College of Surgeons, Casts of the Brain, 235  
 Colour, Bright, in Animals, 148, 208  
 Colour in Flowers, 28, 47  
 Coloured Shadows, 406  
 Columnar Formation in Mud Banks, 285  
 Comber (Thos.), Insects and Colour in Flowers, 47  
 Comets: Borrelly's, 115, 229; Winnecke's, 228, 295, 308, 349, 473; Coggia's, 238, 295; Encke's, 134, 169, 287, 294, 308, 328, 365, 387; Halley's, 270, 286; Comet of 1766, 489; Comet of 1812, 446; Comet of 1840, 407  
 Comets, Guillemin on, 196  
 "Cone (The) and its Sections," by S. A. Renshaw, 404  
 Cook, Captain, Monument to his Memory, 153  
 Cooke (Dr. M. C.), Gums and Resins in India Museum, 252; Pollen Grains, 307  
 Copal Trees of Zanzibar, 414  
 Coral Reefs, 456  
 Cornu (M. A.), Velocity of Light and Sun's Parallax, 274  
 Costa Rica, Survey of, 333  
 Cousin Marriages, 406  
 Cremation, Chemistry of, 33  
 Crookes (Wm., F.R.S.), his Radiometer, 494  
 Cryptogamic Society, Scottish, 497  
 Crystallography, Prof. Maskelyne's Lectures, 34, 56  
 Crystal Palace School of Art, Science, and Literature, 57  
 Crystals, Morphology of, 187  
 Cruelty, Psychology of, 149  
 Ctenophore, Embryology of the, 76  
 Cunningham, (D.D., M.B.), Fungi in Opium Blight, 424; Microscopical Researches on Cholera, 444  
 Currents in Air and Sea, 186  
 Cuttler, Mr., and Section Cutting, 167  
 Cyclones, 317  
 Dalton's First Table of Atomic Weights, 52  
 Darwin (Chas., F.R.S.), "Descent of Man," 305  
 Darwin (George), Endowment of Research, 27; Cousin Marriages, 406  
 "Darwinism," by Oscar Schmidt, 267  
 Dawkins (Prof. W. Boyd, F.R.S.), Northern Range of Fallow Deer, 112, 226; "Cave Hunting," 302

- Dawson (Principal J. W., F.R.S.), Marine Boulder Clay, 306  
 Death's-head Moth, 427  
 Deer, Fallow: its Geographical Distribution, 71, 112; in England in Pleistocene Times, 210  
 "Deep-sea Fishing," by E. W. H. Holdsworth, F.L.S., 421  
 Deep-sea Researches, 148  
 Deductive Method in Physical Science, by Helmholtz, 149, 211  
 "Dental Pathology and Surgery," by S. J. A. Salter, F.R.S., 147  
 Denton (S. G.), Thermometer Scales, 427  
 De Rance (Chas. E.), Southport Aquarium, 393; Arctic Geology, 447, 467, 492, 508  
 "Development of Man," by Ernst Hæckel, 4, 22  
 D'Halloy (D'O.), Obituary Notice of, 254  
 Diatomaceæ in Coal Ashes, 475  
 Dissipation of Energy, 454  
 Distant (W. L.), Thomson's "Malacca," 248  
 Dobson (G. E.), *Anabas scandens*, or Climbing Perch, 109  
 Dohrn (Dr.), Naples Zoological Station, 496  
 Domestication of Animals, 317  
 Donati (Prof.), Inscription to his Memory, 75  
 Drayson (Lieut.-Col., R. A.), "Proper Motion of the Fixed Stars," 66  
 Dresser (H. E., F.Z.S.), "Birds of Europe," 485  
 Drosere, 47  
 Drysdale (Dr. John), Electric Conductivity of Nerves, 247  
 Dublin: Royal Irish Academy, 76, 140, 279, 340, 412; Royal Society, 413; Trinity College, 17, 115, 294; University, 17; Geological Society, 334, 400; Zoological Society, 334; Royal College of Science, 115; Proposed Museum of Science and Art, 135  
 Dulwich College, Scientific Lectures, 57  
 Dundee, Proposed College at, 116  
 Durouf (M.), his Aeronautical Experiments, 369; Aeronautics, 467  
 Duseigneur-Kléber (M. E.), "The Silkworm Cocoon," 206  
 Dyer (Prof. W. T., F.L.S.), Royal Agricultural Society and the Potato Disease, 67, 128; Tree Aloes of South Africa, 89  
 Dynamical Evidence of Molecular Constitution of Bodies, 357, 374, 486
- Earth and Sun as Forces in Chemistry, 324  
 Earthquakes: 414; Carnarvonshire, 57; Innsprück, Smyrna, 77; Chili, 94; Pyrenees, America, 173; Philippine Islands, 194; Ravenna, 255, 413; Carniola, Algeria, 313; Mexico, 396  
 Eastbourne Natural History Society, 155  
 Eclipses of the Sun: April 6, 1875, 201, 215, 228, 235, 312, 351, 354, 371, 394, 412, 452, 474, 490; A.D. 878, 305; A.D. 1715, 507; A.D. 1900, 472  
 Edinburgh: Botanical Society, 311; Museum of Science and Art, 116; Royal Society, 120, 179, 319, 380, 400; Meteorological Society, 319; Proposed Aquarium, 427; University—Meeting under the Presidency of the Duke of Edinburgh, 115; University, 255, 516  
 Education, Agricultural, 104  
 Education, Female, 154, 236, 314, 373, 435  
 Education in Science, Address by Sir John Lubbock, Bart., F.R.S., 21  
 Education, *Monthly Journal of*, 486  
 Electric Conductivity of Nerves, 247  
 Electric Lamp, 154  
 Electric Telegraph, Progress of the, 390  
 Ellis (A. J., F.R.S.), "Musical Duodenes," 88  
 "Embryology, Elements of," by M. Foster, M.A., F.R.S., and F. M. Balfour, B.A., 126  
 Eneke's Comet, 134, 169, 228, 270, 287, 294, 308, 328, 365, 387  
 "Encyclopædia Britannica," Ninth Edition, 343  
 Endowment of Research, 1, 27; Sir J. Herschel on, 347  
 Energy, Dissipation of, 454  
 English Arctic Expedition (*See Arctic Exploration*)  
 "English Men of Science," by F. Galton, F.R.S., 161  
 Entomological Society, 79, 160, 239, 399, 459  
 Eocene Mammals, New Order of, 368  
 Esparto Grass, 333  
*Eucalyptus globulus*, 436  
 Everett (Prof. J. D., D.C.L.), Mirage, 49, 69  
 Explosions, Accidental, Lecture by Prof. F. A. Abel, F.R.S., 436, 477, 498
- Fallow Deer, Geographical Distribution of, 71, 112, 226; in England in Pleistocene Times, 210; Fossil Remains in Malta, 247  
 Faraday Lecture at Royal Institution, 411  
 Fatigue, Law of, regulating Muscular Exertion (*See Muscular Mechanical Work*)  
 Fehling (Dr. Hermann v.), New Chemical Dictionary, 165  
 Female Education in Science, 154, 236, 314; London University, 373; School of Medicine for Women, 435  
 Ferrel (W.), Constant Currents in Air and Sea, 186  
 Fertilisation of Flowers by Insects, 32, 110, 169  
 Fetis (F. J.), "History of Music," 125  
 Fish, Acclimatisation of American, 476  
 Fish; Movements of the Herring, 151  
 Fish, Nest of, 48  
 Fisher (R. C.), *Hoplophora decumana*, 364  
 Fisheries of India and Burmah, 175  
 "Fisheries of the British Islands," by E. W. Holdsworth, F.L.S., 421  
 Flames, Sounding and Sensitive, 45, 88, 129  
 Flight of Birds, 364  
 Flint Celt, 466  
 Flowering of the Hazel, 466, 507  
 Flowers, Colour in (*See Colour*)  
 Flowers and Bees, 285  
 Flowers destroyed by Birds, 428, 446  
 Flowers fertilised by Insects (*See Fertilisation of Flowers*)  
 Fliückiger and Hanbury's "Pharmacographia," 42  
 Fonville (W. de), the Recent Thaw, 194; Storms in the Atlantic, 290; Meteorological Observations in the Pyrenees, 369; Twenty-three Hours in the Air, 429; Aeronautics, 467; Haloes, 476; Fatal Balloon Ascent—the *Zenith*, 495, 513  
 Formosa, Journey in, 216  
 Forests of Ceylon, 274  
 Forrest (John), "Exploration in Western Australia," 475  
 Fossils in "Trap," 129  
 Foster (M., B.A.), and F. M. Balfour, B.A., "Elements of Embryology," 126  
 Fountain, Monumental, at Paris, 36  
 Fritz (Prof.), Geographical Distribution of Auroras, 14  
 Frog, Cry of the, 48  
 Frogs and Snakes, 167  
 Fryer (Herbert F.), the "Wolf" in the Violoncello, 406  
 "Fungi," by M. C. Cooke, M.A., LL.D., 462  
 Fungi in Opium Blight, 424  
 Fusinieri (Ambrogio), "Degli Studi Fisici," 67
- Gabb (Prof.), Survey of Costa Rica, 333  
 Galton (F., F.R.S.), "English Men of Science," 161  
 Galway Bay, Plants and Ferns of, 434  
 "Gamba" Organ-pipe, 325  
 "Gardeners' Year Book," by R. Hogg, LL.D., 186  
 Garrod (Prof. A. H.), Propeller imitating the Action of the Fin of the Pipe Fish, 429  
 Gaussian Constants, 285  
 Geiger (J. L., F.R.G.S.), "A Peep at Mexico," 84  
 Geikie (Prof. A., F.R.S.), Elie de Beaumont, 41  
 Geographical Distribution of Auroras, 14  
 Geographical Society, 34, 37, 40, 75, 139, 220, 293, 339  
 Geography; International Congress at Paris, 232  
 Geology: Geological Society, 57, 58, 139, 219, 299, 312, 338; Annual Meeting, Medals, 359, 378, 417, 434, 479; Geological Museum, New, 18 Geological Survey of Victoria, 181; Geologists' Association, 179, 319, 418, 457; Geology and the Arctic Expedition, 268, 447, 467, 492, 508; Geology, Past and Future Work of, 290, 315  
 Geometrical Conics, Walker's System of, 445  
 Geometrical Teaching, Report on, 504  
 "Geometry, Descriptive," by W. Watson, Ph.D., 265  
 Gerland (George), "Anthropological Contributions," 384  
 German Arctic Expedition 1869-70, 63  
 German Chemical Society, 200  
 German Manual of Scientific Inquiry, 321  
 Glasgow: Geological Society, 79, 180, 320, 400, 418; Philo-sophical Society, 216, 320; Science Lectures, 233  
 Glass, Hardened, 474  
 Godard (M.), Aeronautics, 467  
 Goldsmid (Col. Sir F. J., C.B.), "Telegraph and Travel," 347  
 Göttingen, Royal Society of Sciences, 459

- Granville (A. R.), Height of Waves, 427  
 Grape-vine, (*See* Vine Disease)  
 Gray (J. E., F. R. S.), Obituary Notice of, 368  
 Green, (J. R., M. A.), "History of the English People," 164  
 Greenland, German Expedition to, 195  
 Greenwich Observatory, Standard Sideral Clock, 431  
 Greenwood (Col. Geo.), Origin of the Chesil Bank, 386  
 Gregorian Year, 414  
 Gresham College, 2, 28, 516  
 Groves (Thos. B.), The Chesil Bank, 506  
 Gum, Kauri, of New Zealand, 414  
 Gum Trees, Blue, at Kew Gardens, 216  
 Gunpowder, Explosions of, 498  
 Guthrie (Principal F.), Trade Winds, 348; Flight of Birds, 364  
 Gyrostat Problem, 385, 424
- Hastings: Philosophical Society, 94; Aquarium, 216  
 Haeckel (Ernst), "Development of Man," 4, 22  
 Haematozoa, Nematode, Pathological Significance of, 363  
 Hall (T. W., M.D.), Sun and Earth as Forces in Chemistry, 324  
 Halley's Comet, 270, 286  
 Halos, Solar, 395, 497  
 Hamilton's String Organ, 308  
 Hanbury (Daniel, F. R. S.), Obituary Notice of, 428  
 Hanbury and Flückiger's "Pharmacographia," 42  
 Hancock's "Birds of Northumberland and Durham," 281  
 Harrison (J. P.), Phœnician Characters in Sumatra, 228  
 Hart (H. C.), Botany of Galway Bay, 395  
 Harting (J. E., F. L. S.), White's "Seabone," 423  
 Hartwig (G., M.D.), "The Aerial World," 385  
 "Hawaiian Archipelago, The," by Isabella J. Bird, 322  
 Haughton (Prof. Samuel, F. R. S.), Muscular Exertion, 464, 488  
 Hayden (Prof.), Geological Survey of the United States, 430  
 Hazel, Flowering of the, 466, 507  
 Heidelberg University, 173  
 Helmholtz on the Deductive Method in Physical Science, 149, 211; "Sensations of Tone," 516  
 Hennessey (J. H. N., F. R. A. S.), White Lines in Solar Spectrum, 318  
 Herapath's Balance, 348  
 "Heredity," by Th. Ribot, 503  
 Herring, Movements of the, 151  
 Herpetology, European, 271, 447  
 Herschel (Prof. A. S.), Sounding and Sensitive Flames, 6, 45, 88  
 Hind (J. R., F. R. S.), Re-appearance of Encke's Comet, 134, 169; Eclipse of the Sun, 201  
 Hinrichs (Gustavus), Muscular Exhaustion and Restoration, 426  
 "History of the English People," by J. R. Green, M. A., 164  
 Hoffmeyer (Capt.), Weather Charts, 208, 312  
 Homann (Dr. A. W.), Faraday Lecture at Royal Institution, 411  
 Hogg (R., LL.D.), "Gardener's Year Book," 186  
 Homeyer (Herr), African Exploration, 456  
 Honeyman (Dr. D.), Fossils in "Trap," 129  
 Hong Kong, Typhoon at, 168  
 Hooker's "Synopsis Filicum," 273  
 Hopkins (Rev. G. H.), Drosera, 47  
*Hoplophora decumana*, 434  
 Horrocks (Jeremiah), Memorial to, 31  
 Horticulture in Belgium, 154  
 Horticultural Society, 79, 120, 254, 278, 380, 398, 418, 458  
 Huddersfield Naturalists' Society, 396  
 Humboldt's "Natur- und Reisebilder," 435  
 Hurricane at Hong Kong, 195  
 Hutchinson (T. J., M. A. I.), "Two Years in Peru," 241, 262  
 Huxley (Prof. T. H., F. R. S.), Development of the *Columella auris* in the Amphibia, 68; Classification of the Animal Kingdom, 101; elected Foreign Associate of Belgian Academy, 173
- Ice Barriers, Arctic, 87  
 Icebergs, 58, 476  
 Ice Caves, 327  
 Ice Phenomena in the Lake District, 309  
 Iceland, Volcano in, 514  
 India, Science in, 18, 355, 516  
 India, Sea Fisheries, 175  
 India Office, Natural History Collections, 16
- Indian Meteorology, 145  
 Indian Museum, 77, 252, 413  
 Indian Tobacco, 373  
 Indian Venomous Snakes, 377  
 India-rubber Plants, 274, 395, 436  
 Ingleby (C. M.), Ring Blackbird, 187, 228  
 Insects, Accidental Importation of, 427  
 Insects, Discovery of Remains of, 88  
 Insects and the Colour of Flowers, 6, 28, 47  
 Insects, Fertilisation of Flowers by (*See* Fertilisation)  
 Instruments, Scientific, Loan Collection of, 301, 355  
 International Coinage Conference, 273  
 International Metric Commission, 54  
 Inventions, Protection for, 141, 190  
 Iron and Steel Institute, 515  
 Iron Ore in Norway, 456  
 Iron Pyrites, Softening of, 248, 269, 285  
 Isinglass, Manufacture of, 136  
 Islington, Proposed Public Libraries, 17  
 "Ismaïlia," by Sir Samuel W. Baker, Pacha, F. R. S., 24  
 Italy: Science in, 97, 98, 237; New Scientific Journal, 236;  
 Prehistoric Antiquities of, 293; Spectroscopic Society, 337;  
 Expedition to the Sources of the Nile, 356; Botanical Journal, 417
- Jaborandi, Botanical Source of, 274, 414  
 Jackson (John R.), New Zealand Plants for Paper-making, 212; Botany in Queensland, 271  
 Jamain and Forney (MM.), "Les Roses," 85  
 Japan: Public Library in, 56; Medical Science in, 295  
 Jardine (Robt., B.D.), "Psychology of Cognition," 422  
 Jardine (Sir William, Bart.), Obituary Notice of, 72  
 Java, Cinchona Cultivation in, 18  
 Jettelles (L. H.), Geographical Distribution of the Fallow Deer, 71  
 Jenkins (H. M.), The Royal Agricultural Society and the Potato Disease, 109  
 Jevons (Prof. W. Stanley, F. R. S.), Galton's "English Men of Science," 161; "Heredity," by Th. Ribot, 503  
 Jewish Week, Origin of, 363  
 Johnson (Wm. H.), Progress of the Telegraph, 390, 450, 470, 510  
 Just (D. L.), "Botanic Year Book," 284  
 Jute, 314
- Keller (Franz), "The Amazon and Madeira Rivers," 241, 262  
 Kent (W. Saville), Mounting Acari for the Microscope, 406  
 Kentucky, Caves of, 414  
 Kew Gardens, 14, 216, 254  
 Kiddle (Capt. W. W.), The Thresher and the Whale, 234;  
 Height of Waves, 386  
 Kiernan (Francis, F. R. S.), Obituary Notice of, 193  
 Kinahan (G. H., M. R. I. A.), "Valleys, Fissures, Fractures, and Faults," 403  
 King (Dr.), Report on Calcutta Botanic Gardens, 18  
 Kingfisher, Belted, Habits of the, 227  
 King's College, 313  
 Kingsley (Rev. C.), Obituary Notice of, 253  
 Kirkes' "Physiology," 227, 248, 363  
 Kitchener (Frances A.), "Botany for Home and School Use," 147  
 Krefft (Gerard) and the Sydney Museum, 236
- Landslips in Denmark, 334  
 Lankester (Edwin, M.D., F. R. S.), Obituary Notice of, 15  
 Lankester (E. Ray), Development of Mollusca, 48  
 Lalande's *Etoile Singulière*, 287  
 Lateau (Louise), her Abstinence from Food, 455  
 Lea (Isaac, LL.D.), "The Unionidæ," 246  
 Lectures to Women on Physical Science, 74  
 Leipold (Dr. G.), Mean Height of Europe, 475  
 Lemon Plant, Dry Rot in the, 456  
 Leverrier (M.), Stellar Observations, 36; Paris Observatory, 154;  
 Planetary Theories, 249; Comets and Small Planets, 294  
 Lewis (T. R., M. B.), Nematode Haematozoa, 363; Microscopical Researches on Cholera, 444  
 Ley (W. Clement), Upper Currents over Areas of Frost, 269;  
 Storm Warnings from the United States, 405  
 Leyden University, 294, 312  
 Libyan Desert, Vegetation of, 137; Photographs of, 273

- Lichtenstein (Maurice), Gresham Lectures, 28  
 "Liebig's Contributions to Experimental Chemistry," Lecture by Dr. A. W. Hofmann, 411  
 Light, Velocity of, 134, 274, 373  
 Lightning Conductors, 17  
 "Lightning, Struck by," 405  
 Linccum (Dr. G.), Obituary Notice of, 237  
 Lingwood (Geo.), Decomposition of Iron Pyrites, 269  
 Linnean Society, 58, 77, 78, 101, 119, 159, 179, 258, 298, 337, 378, 417, 458, 500  
 Livingstone's "Last Journals," 142, 182  
 Liverpool Geological Society, 155  
 Lizards; the Tock-Tay, or Large House Lizard of Bengal, 272  
 Lloyd (Humphrey, D.D.), "Treatise on Magnetism," 221  
 Loan Collection of Scientific Instruments, 301, 355  
 Lobsters in Cans imported from America, 93  
 Lockyer (J. Norman, F.R.S.), Rumford Medal awarded to, 55, 156; New Map of the Solar Spectrum, 238; Lectures on Spectrum Analysis, 254  
 Loewy (B., F.R.A.S.), Weinhold's "Experimental Physics," 482  
 Logarithmic Tables, 424  
 London University, 27, 236, 254, 373  
 Lubbock (Sir John, Bart., F.R.S.), Scientific Education, 21; Bees, Wasps, and Ants, 159; "Origin of Civilisation," 401; Ancient Monuments Bill, 481  
 Lyell (Sir Charles, Bart., F.R.S.), Obituary Notices of, 332, 341  
 M'Coy (Frederick, F.G.S.), Geological Survey of Victoria, 181  
 M'Farlane (D.), a Gyrostat Problem, 385, 424  
 Maclay (Dr. Von M.), Travels in Tabor, 413  
 M'Leod (Herbert), Meteor at Orleans, 427  
 M'Nab (Prof.), "Movements of Water in Plants," 62  
 M'Nab (W. K.), Cunningham on Fungi in Opium Blight, 424  
 "Magnetism, Treatise on," by H. Lloyd, D.D., 221  
 Magnus (Philip), London University, 27  
 Malacca, Indo-China, and China," by J. Thomson, F.R.G.S., 207, 248  
 Malta, Tertiary Deposits, 516  
 "Mammals," by H. and A. Milne-Edwards, 463  
 Mammoth Cave, 256  
 "Man, Descent of," by Charles Darwin, F.R.S., 305  
 "Man and Nature," by G. P. Marsh, 82  
 "Mankind, Races of," by Robert Brown, M.A., 128  
 Manchester: Aquarium, 36; Exhibition at, 175; Geological Society, 395, 416; Literary and Physical Society, 19, 79, 99, 136, 180, 279, 319, 340, 418, 459; Owens College, 241  
 Marcoy (Paul), "Travels in South America," 241, 262  
 Marine Boulder Clay, 306  
 Marine Strata, Calcareous and Siliceous Remains, 186  
 Markham (Commander A. H., R.N.), appointed to the Arctic Expedition, 92, 114, 293, 474; "Whaling Cruise to Baffin's Bay," 404  
 Markham (Clements R., C.B., F.R.S.), Dr. Petermann and Arctic Exploration, 85; "The Countess of Chinchon," 383  
 Mars, 387  
 Marsh (G. P.), "Man and Nature," 82  
 Marsh (Prof. O. C.), Exploration of the Rocky Mountains, 237; New Order of Eocene Mammals, 368  
 Maskelyne (Prof. N. S., F.R.S.), Lectures on Crystallography, 34, 56; Morphology of Crystals, 187  
 Mason (Sir Josiah), Birmingham College of Science, 331  
 Massachusetts, Survey of, 497  
 Mastodon, Examination of the Stomach of a, 237  
 Mathematical Society, 60, 139, 258, 337, 398, 478  
 Mathieu (L.), Obituary Notice of, 372  
 Mayer (John), Science Lectures at Glasgow, 233  
 Medical Microscopical Society, 279  
 Mesasides, Locomotion of, 29  
 Melbourne; Great Telescope, 94; Science at, 218; University, 333  
 Meldrum (C.), Periodicity of Rainfall, 327  
 Melliss (G. C., F.G.S.), "St. Helena," 501  
 Mental Science, Journal of, 19  
 Meridian, International Commission for Measuring the, 273  
 Metal Glass, 474  
 "Metallurgy, Elements of," by J. A. Phillips, C.E., 266  
 Meteorological Observations in the Pacific, 405; in the Pyrenees, 369  
 Meteorological Society, 78, 160, 259, 339, 417  
 Meteorological Telegrams, 394  
 Meteorology: Arctic, 434; Climate of Scotland, 329; Indian, 145; in England, 446; Scottish Meteorological Society, 456  
 Meteors, 154; Bengal, 295; Paris, 334; Oleron, Orleans, 396, 427; France, 413, 497  
 Meteor Shower, A.D. 855, 407  
 Metric System, International Conference, 356  
 Metric Commission, International, 54  
 Metropolitan Scientific Association, 36  
 "Mexico, A Peep at," by J. L. Geiger, F.R.G.S., 84  
 Meyer (Dr. A. B.), New Bird of Paradise, 208; Rhinoceros in New Guinea, 268; his Critics, 566  
 Mice of North America, 273  
 "Micrographic Dictionary," 267, 286, 307, 328  
 "Microscope and its Revelations," by W. B. Carpenter, M.D., F.R.S., 283  
 Microscopical Science, Journal of, 218  
 Microscopical Society, 40, 120, 220, 300, 379, 480  
 Microscopical Researches on Cholera, 444  
 Microscopy; *Hoplophora decumana*, 364  
 Migration of Birds, 5, 135, 149, 234  
 Milne-Edwards (H. and A.), New Work on Mammals, 463  
 Mirage, by Prof. J. D. Everett, D.C.L., 49, 69  
 Moas of New Zealand, 289  
 Mogridge (J. T., F.L.S.), Obituary Notice of, 114; "Harvesting Ants and Trap-door Spiders," 245  
 Molecular Constitution of Bodies, Dynamical Evidence of, 357, 374, 486  
 Mollusca, Development of, 48  
 Molluscs, Accidental Importation of, 427  
 Moore (S. W., F.C.S.), Physiological Chemistry, 283; Morphology of Crystals, 187  
 Morse Code, 328  
 Moss (R. J.), The Arctic Expedition, 348  
 Mott (F. T.), Insects and Colour in Flowers, 28  
 Mud Banks in the Indian Ocean, 135; on Malabar Coast, 187; Columnar Formation in, 285  
 Müller (Dr. Hermann), Fertilisation of Flowers by Insects, 32, 110, 169  
 Munro (J.), Natural Phenomena in South America, 329  
 Murphy (J. J.), Insects and Colour in Flowers, 28; Origin of Bright Colour in Animals, 148, 208  
 Muscular Mechanical Work done before Exhaustion, 256, 276, 426, 464, 488  
 "Music, History of," by W. Chappell, F.S.A., 123, 208  
 Music, Science in, 88  
 Nachtigal (Dr.), his Travels in the East, 216  
 Nares (Capt., R.N.), and the Arctic Expedition, 114, 134, 293  
 Naples, Zoological Station, 333, 496  
 Naval Architects, Institution of, 394, 408  
 Nebula, Variable, 489 (*See Stars*)  
 Nerves, Electric Conductivity of, 247  
 Nest of young Fish, 48  
 Neumayer (Dr. G.), Manual of Scientific Inquiry, 321  
 New (Rev. C.), Obituary Notice of, 475  
 Newcastle, College of Physical Science, 75  
 New Guinea, Rhinoceros in, 248, 268  
 Newton (Prof. Alfred, F.R.S.), Migration of Birds, 5; Zoology, 305; Phenological Phenomena, 408  
 New Zealand: Introduction of English Birds and Bees, 35; Institute, 135; Acclimatisation of Salmon, 209; Plants for Paper Making, 212; Salmon Eggs and Birds exported to, 217; Timbers, Durability of, 254; Remains of Moas, 289; Kauri Gum, 414; Wellington Philosophical Society, 419  
 Nichols (R. C., F.S.A.), Alpine Club Map of Switzerland, 8; Dynamical Evidence of Molecular Constitution, 487  
 Nipher (F. E.), Muscular Mechanical Work done before Exhaustion, 256, 276  
 Nitro-glycerine, action of its explosion on Fish, 76  
 Nova Zembla, Natural History of, 22  
 Observatories: Algiers, Bordeaux, Toulouse, 496; Greenwich, New Standard Sidereal Clock, 431; Paris, 36, 134, 154, 272, 273, 294, 373, 457, 476; Pola, 394; Pyrenees, 173; Rio Janeiro, 395  
 Ocean, Vertical Distribution of Temperature in the, 157  
 Ocean Waves, 444  
 Oliver (D., F.R.S.), Lessons in Elementary Botany, 226  
 Olive Oil in Tunis, 35

- Opera House at Paris, Scientific Appliances, 349, 369  
 Opium Blight, Fungi in, 424  
 Opium Cultivation in Asia Minor, 35  
 Organ Pipes, 325  
 Owens College, Manchester, 241  
 Oxford, Science at, 92, 394, 497, 515<sup>1</sup>  
 Oyster Cultivation at Utah, 217  
 Oysters, Scarcity of, 93<sup>1</sup>
- "Pacific States, Native Races of the," Bancroft's, 442  
 Palæontographical Society; "Monograph of the Post-tertiary Entomostraca of Scotland," 128  
 Palestine Survey Expedition, 154  
 Paper, New Material for, 33  
 Paper-making, New Zealand Plants for, 212  
 Paris: Academy of Sciences, 17, 20, 40, 60, 75, 80, 100, 120, 134, 140, 160, 174, 180, 196, 220, 235, 240, 259, 280, 300, 320, 340, 356, 360, 380, 413, 440, 460, 480, 500, 520; Anniversary Meeting, 178; Election of President, 273; its origin, 213; Acclimatisation Society, 56, 98, 219, 475; American Society, 135; Anthropological Society, 98; Easter Week at the Sorbonne, 516; Geographical Society, 80, 120, 140, 174, 196, 236, 254, 294, 515, 516; International Congress of Geographical Science, 232; International Metric Commission, 54; Monumental Fountain at, 36; Observatory, 36, 75, 154, 235, 272, 273, 294, 373, 457, 476; Science at the New Opera House, 349, 369; School of Medicine, 56; Telegraphic Administration, 394  
 Parker (Prof.), Hunterian Lectures on the Vertebrate Skull, 9, 314  
 Pasteur (Prof. L.), Royal Society's Medal presented to, 155  
 Pathological Society, 373  
 Pavesi (Dr. Pietro), Sharks, 18  
 Perch, Climbing, 109  
 Petermann (Dr. A.), Arctic Exploration, 37, 85  
 "Peru, Two Years in," by T. J. Hutchinson, M.A.I., 241, 262  
 "Pharmacographia," by Flüciger and Hanbury, 42  
 Phenological Phenomena, 408, 476  
 Philadelphia: Academy of Natural Sciences, 20, 93, 99, 255, 419; Centennial Exhibition, 76  
 Phillips (J. A., C.E.), "Elements of Metallurgy," 266  
 Phœnician Characters in Sumatra, 228  
 Photographic Image of the Spectrum, Influence of Pigments on the, 505  
 Photographic Society, 236  
*Phylloxera vastatrix* and the Vine Disease, 11, 48, 56, 286  
 Physical Society, 35, 59, 99, 379, 399, 439, 479  
 "Physics, Experimental," by Prof. A. F. Weinhold, 482  
 "Physiology," "La Vie," by Dr. Gustave Le Bon, 246  
 "Physiology, Animal," by J. Cleland, M.D., F.R.S., 504  
 "Piedmont-Cambridge (Rev. O.), "Trap-door Spiders," 245  
 Pigeons (D.), Struck by Lightning, 405  
 Pigeons, Carrier, 174, 237  
 Pigments, their Influence on the Photographic Image of the Spectrum, 505  
 Pine-apples from Portugal, 254  
 Pipe Fish, a Propeller imitating the action of its Fin, 429  
 Planets: New, 314; New Minor, 349; Mars, 387; Minor, 428  
 Planetary Theories, by M. Leverrier, 249  
 Plants, Discovery of Remains of, 88  
 Plarr (Mary J.), Bees and Flowers, 248  
 Poison in the Bamboo Cane, 18  
 Poisoning, Researches by Prof. Böhm, 334  
 Pole (Dr. W., F.R.S.), Alteration of Note of Railway Whistles, 232  
 Pollen Grains, 286, 307, 328  
 Potato Disease, 56, 67, 109, 128, 149, 166, 355  
 Potato Beetle, 476  
 Prestwich (Prof. J., F.R.S.), Past and Future Work of Geology, 290, 315  
 Prideaux (E.), Kirkes' Physiology, 248  
 Priestley Centenary, in Northumberland (U.S.), 136  
 Pringle (E. W.), Transit of Venus, 306  
 Protection for Inventions, 141, 190  
 Psychology of Cruelty, 149  
 Psychology: "Mind" and a Quarterly Review," 294  
 Pyle-Smith (Dr.), Hæckel's "Development of Man," 22
- Queensland: Exploration in, 237; Botany in, 271  
 Quetelet (M. E.), Temperature of Brussels, 444
- Race, its Relation to Species, 129  
 "Races of Mankind," by R. Brown, M.A., 128  
 Radiation, Attraction and Repulsion arising from, 494  
 Railway Accidents, 174  
 Railway Whistles; Alteration of Note in Trains meeting each other, 232  
 Rain, its Action in Calming the Sea, 279  
 Rainfall, Periodicity of, 327  
 Rain of Ashes, Norway and Sweden, 515  
 Rayleigh (Lord, F.R.S.), Insects and the Colours of Flowers, 6;  
 Hamilton's String Organ, 308; Dissipation of Energy, 454  
 Renshaw (A. G.), Ants and Bees, 306  
 Renshaw (S. A.), "The Cone and its Sections," 404  
 Reichenbach (Count O.), Gaussian Constants, 285  
 Research, Endowment of (*See* Endowment of Research)  
 Research, Scientific, *The Times* on, 102  
 Rhinoceros in New Guinea, 248, 268  
 Rhubarb, 314  
*Rhynchosaurus atreps*, 8  
 Ribot (Th.), "Heredité," 503  
 Riga, Society of Naturalists, 459  
 Right-handedness, 140  
 Ring Blackbird, 187, 209, 228  
 Rivers, Alteration of Levels, 314  
 Rivers, Change of Course of, 229  
 Rocks, Disintegration of, 356  
 Rodwell (G. F., F.C.S.), Heat, 139  
 Rohlf's (Dr. G.), Exploration in Africa, 356  
 Romanes (G. J.), Locomotion of Medusidae, 29  
 Romilly (Lord), Protection for Inventions, 190  
 Roscoe (Prof. H. E., F.R.S.), Dalton's First Table of Atomic Weights, 52  
 "Roses, Les," by MM. Jamain and Forney, 85  
 Royal Institution, 411, 415, 456  
 Royal Society, 34, 55, 92, 138, 157, 258, 278, 296, 318, 334, 337, 377, 417, 439, 458, 494, 496, 499, 518; Presentation of Medals, 155; its Present Condition (President's Address), 175, 196; French Account of its Origin, 213  
 Rumford (Count), Complete Works of, 103  
 Russian Forests, 251
- St. Andrew's University, 76, 196, 333  
 "St. Helena," by J. C. Melliss, F.G.S., 501  
 Salisbury (The Marquis of), Scientific Education, 241  
 Salmon, Acclimatisation of, in Otago, 209  
 Salter (S. J. A., F.R.S.), "Dental Pathology and Surgery," 147  
 Sandal-wood, Trade in, 395  
 "Sandwich Islands, The," by Isabella J. Bird, 322; Volcanic Action in the, 386  
 Saxby (H. L., M.D.), "Birds of Shetland," 81  
 Scheele, Monument at Stockholm to, 216  
 Schreiber (Oscar), "Darwinism," 267  
 Schmidt (Dr. Egid), "European Herpetology," 271  
 Schweinfurth (Dr. G.), African Photographs, 273; African Exploration, 496  
 Scientific Club, 356  
 Science Commission, 457  
 Scientific Education, The Marquis of Salisbury on, 241  
 Scientific Inquiry, German Manual of, 321  
 Scientific Surveys, 381  
 Selater (P. L., F.R.S.), Zoological Gardens, 87; Lectures at the Zoological Gardens, 513  
 Scorpions, Suicide of, 29, 47  
 Scotland: Change of Climate, 329; "Scotland, Post-tertiary Entomostraca, Monograph of," 128; University Development in, 115; Scottish Cryptogamic Society, 497; Scottish Meteorological Society, 456; *Scottish Naturalist*, 257  
 Scott (Robert H., F.R.S.), Hoffmeyer's Weather Charts, 208  
 Sea-horse, 429  
 Seals, Destruction of, 93, 373  
 "Sensation and Intuition," by James Sully, M.A., 44  
 Sensitive Flames, 45, 88, 129  
 Serpent, New American, 255  
 Settle, Caves at, 304, 514  
 Shadows, Coloured, 406  
 Sharks in Suez Canal, 174  
 "Sheep, History, Structure, and Economy of," by W. C. Spooner, M.R.V.C., 106  
 Shell-Fish, importation of, 394  
 "Shetland, Birds of," by H. L. Saxby, M.D., 81

- Siam; Invitation by the King to Royal and Astronomical Societies, 215  
 Silk-culture, 456  
 "Silkworm Cocoon," by M. Duseigneur-Kléber, 206  
 Simon (Eugène), "Spiders of France," 224  
 Smith (A. Percy), Chameleon Barometer, 365  
 Smith (E. J. A'Court), Flint Celt, 466; Discovery of Remains of Plants and Insects, 88  
 Smith (George), "Assyrian Discoveries," 441  
 Smith (Hermann), "Gamba" Organ-pipe, 325; Sounds of the String Organ, 425  
 Smith (W. G.), Pollen Grains, 286, 328  
 Smith (Dr. W. R.), Origin of the Jewish Week, 363  
 Snakes and Frogs, 167  
 Snake Poisoning, 377  
 Snow Storms, 334  
 Society of Arts, 35, 94, 141, 217, 237, 255  
 Social Science Association, 435  
 Solar Parallax, M. Pulseux's Calculations, 474  
 Solar Physics, M. Becquerel on, 132  
 Solar Spectrum, White Lines in, 318  
 Sorby (H. C., F.R.S.), Medal of Royal Society presented to, 156; Diatomaceæ in Coal Ashes, 475  
 Sounding and Sensitive Flames, 6, 45, 88  
 South American Travel, 241, 262  
 Southport Aquarium, 393  
 Southwell (Thos.), Thermometer Scales, 286  
 Spain, Science in, 372  
 Spalding (D. A.), Sully's "Sensation and Intuition," 44; Jardine's "Psychology of Cognition," 422  
 Species, in relation to Race, 129  
 Spectroscopy: Transit of Venus, 171; Stars, 236; New Map of the Solar Spectrum, 238; Spectrum of Coggia's Comet, 238; Influence of Pigments on the Photographic Image of the Spectrum, 505; White Lines in Solar Spectrum, 318  
 Spider, Crane or Windlass, 476  
 Spiders, Ingenuity of, 8  
 "Spiders of France," by Eugène Simon, 224  
 "Spiders, Trap-door," by J. T. Moggridge, F.L.S., 245  
 Spitzbergen, Natural History of, 22  
 Spooner (W. C., M.R.V.C.), "History, Structure, Economy, and Diseases of Sheep," 106  
 Spottiswoode (W., F.R.S.), Presentation of Medals at Royal Society, 155  
 Standards of Weight and Measure; Report of the Warden of the Standards, 270  
 Stanley (H. M.), his African Expedition, 77, 153 (*See* Livingstons' "Last Journals")  
 Starfish, Fossil, 476  
 Stars: Antihelm's, 407; Binary, Bootis; New Variable in Orion, 348; R. Hydra, 349; Drayson's "Proper Motion of the Fixed Stars," 66; Falling, 154; Red, 446; Southern Double, 428; Spectroscopic Observations of, 236; "Temporary," of Tycho Brahe and Kepler, 249; Variable, 269, 308, 328, 334, 365, 387, 428, 473; Weight of a Fixed Star, 314  
 Statistical Society, 294  
 Stebbing (T. R. R.), Natural Phenomena in South America, 386  
 Stewart (Prof. B., F.R.S.), Dr. Lloyd's "Treatise on Magnetism," 221  
 Stigmara, Structure of, 136  
 Stillman (W. J.), Influence of Pigments on the Photographic Image of the Spectrum, 505  
 Stockholm, Science at, 459  
 Stone (W. H.), "Wolf" in the Violoncello, 466  
 Stone Implements from the United States, 190, 215  
 Storms in the Atlantic, 290, 312  
 Storm Warnings from the United States, 405  
 Strange (Lieut.-Col. A., F.R.S.), Transit of Venus, 130  
 Stratford, Lectures at, 254  
 Stratification in Electrical Discharges, 518  
 String Organ, Hamilton's, 308, 425  
 Sub-Wealden Exploration, 236, 267, 284, 313, 457  
 Sugar Cultivation in Porto Rico, 35  
 Suicide of Scorpions, 29, 47  
 Sully (Jas., M.A.), "Sensation and Intuition," 44  
 Sumatra, Phœnician Characters in, 228  
 Sun, The; Preliminary Inquiry into the Existence of the Elements not previously traced, by J. Norman Lockyer, F.R.S., 334; Sun and Earth as Forces in Chemistry, 324; Sun's Parallax, 274, 489; Sun-spots, 416  
 Surveys, Scientific, 381  
 Switzerland, Government Map of, 116; Map of the Lake of Geneva, 372  
 Sydney Museum, 236  
 Symons (W.), Carbon Cells and Plates for Galvanic Batteries, 8  
 Tea, Trade in, 435  
 Teeth of the Newt, Lizards, and Ophidia, 157  
 Telegraph, Progress of the, 390, 459, 470, 510  
 "Telegraph and Travel," by Col. Sir J. F. Goldsmid, C.B., 347  
 Telegraphy, International Conference on, 457  
 Telescope for Paris Observatory, 272  
 Telescopes, Equatorial, Inventor of Clock Movement applied to, 166  
 Temperature of Brussels, 444  
 Temperature of the Ocean, 157  
 Temperature Chart of the United States, 267  
 Texas, Survey of, 155  
 Thaw, Recent, 193  
 Thermometer Scales, 286, 427  
 Thermometers, New Notation for, 457  
 Thibet, Exploration in, 293  
 Thomson (J., F.R.G.S.), "Malacca, Indo-China, and China," 207, 248  
 Thomson (Prof. C. Wyville, F.R.S.), Reports on the Challenger Expedition, 95, 120, 287, 297  
 Thresher, The, and the Whale, 234  
 Times, Weather Chart in the, 473, 497  
 Tissandier (Gaston), Aeronautics, 467; his Ascent in the Zenith Balloon, 495  
 Tobacco Cultivation in Algeria, 436; Indian, 373  
 Tobacco Smoke, 456  
 Tock-Tay, or large House Lizard of Bengal, 272  
 Topham (John), Ingenuity of a Spider, 8  
 Topley (W.), Sub-Wealden Exploration, 284  
 Trade Winds, 348  
 Traill (C.), Improvement of the Zoological Gardens, 68  
 Transit of Venus (*See* Venus, Transit of)  
 Transit of Venus, A.D. 1631, 507  
 "Trap," Fossils in, 129  
 Tree Aloes of South Africa, 89, 254  
 Tree Ferns, 254  
 Trees, Catalogues of, 154  
 Trieste, Scientific Society at, 372  
 Trigonometrical Tables, 424  
 Tunnel between France and England, 273  
 Turner (W., M.D.), "Human Anatomy," 464  
*Zuscarora*, U.S. Steamer; Deep Sea Soundings, 295  
 Tyndall (Prof.), Acoustic Reversibility, 239  
 Typhoon at Hong Kong, 168  
 Umbellula, or Cluster Polyp, 252  
 "Unionida," by Isaac Lea, LL.D., 246  
 University College, 355, 371  
 University Reform, Mr. Disraeli on, 292  
 Upper Currents over Areas of Frost, 269  
 Uranus, Satellites of, 395  
 Utah, Birds of, 136; Oyster Cultivation at, 217  
 "Valleys, Fissures, Fractures, and Faults," by G. H. Kinahan, M.R.L.A., 403  
 Variable Nebula, 489  
 Variable Stars, 269, 308, 334, 365, 387  
 Vegetation of the Libyan Desert, 137  
 Ventilation, Theory of, 296  
 Venus, Transit of; Reports of the Expeditions, 16, 36, 93, 102, 112, 121, 130, 134, 153, 171, 177, 194, 214, 234, 254, 306, 313, 332, 354, 365, 371, 387, 394, 417, 455  
 Venus, Transit of: A.D. 1631, 507  
 Victoria: Aborigines, 155; Agriculture, 361; Geological Survey, 181; Royal Society, 91  
 Victoria Philosophical Institute, 76, 120, 199, 360, 418, 459  
 Vienna, Imperial Academy of Sciences, 420  
 Vine Cultivation, 274, 396  
 Vine Disease in the South-east of France, 11, 56  
 Violoncello, The "Wolf" in the, 466, 466  
 Volcanoes: Sandwich Islands, 386; Iceland, 514; Moluccas, 515  
 Von Heuglin's Travels in Spitzbergen and Nova Zembla, 22

- Walker (Alfred O.), Rhinoceros in New Guinea, 248, 268  
 Waller (Rev. H., F.R.G.S.), Livingstone's "Last Journals," 142, 182  
 Ward (J. C.), Ice Phenomena in the Lake District, 309  
 Ward (Dr. T. O.), *Rhynchosaurus arcticus*, 8  
 Watford Natural History Society, 196, 237, 274, 334, 419  
 Watson (Dr. Forbes), Education in connection with India, 473  
 Watson (Wm., Ph.D.), "Descriptive Geometry," 265  
 Waves, Height of, 386, 427, 444  
 Weather Charts, 208, 312, 473, 497  
 Weinhold (Prof. A. F.), "Experimental Physics," 482  
 Wells, Circulation of Underground Water, 136  
 Werekha (P. N.), Russian Forests, 251  
 Wetterhan (F. D.), Flowering of the Hazel, 507  
 Weyr (Dr.), Mathematical Works by, 283  
 Whale, The, and the Thresher, 234  
 "Whaling Cruise to Baffin's Bay," by A. H. Markham, F.R.G.S. Commander R.N., 404  
 White's "Selborne," 423  
 White (Dr. F. B.), Accidental Importation of Molluscs and Insects, 427  
 Whitmee (Rev. S. J.), Meteorological Observations in the Pacific, 405  
 Whitwell (C. T. L.), Chameleon Barometer, 307; Coloured Shadows, 406  
 Whitworth Exhibitions, 272  
 Willis (Prof. R., M.A., F.R.S.), Obituary Notice of, 535  
 Williams (W. Mattieu, F.C.S.), Arctic Ice Barriers, 87; on the "Complete Works of Count Rumford," 203; Decomposition of Iron Pyrites, 269  
 Williamson (Prof. W. C., F.R.S.), Structure of Stigmaria, 136; Deep Sea Researches, 148; Medal of Royal Society presented to, 156; Section Cutting, 167  
 Wilson (Prof. W. P., of Melbourne University), Obituary Notice of, 333  
 Winnecke's Comet, 228, 295, 308, 349, 473  
 Wire (A. P.), Decomposition of Iron Pyrites, 269  
 "Wolf," The, in the Violoncello, 406, 466  
 Wollaston (G. H.), The Phylloxera, 286  
 Wood (Major Herbert, R.E.), Cause of the Change in the Course of the Amú Darya River, 229  
 Wyman (the late Dr. Jeffries), Memorial of, 274  
 Zanzibar, Copal Trees, 414  
 "Zenith" Balloon Ascent, 495, 513  
 Zodiacal Light, 115, 249, 270, 349  
 Zoological Gardens: Additions to, 18, 36, 58, 77, 95, 116, 136, 155, 175, 196, 218, 237, 256, 274, 295, 315, 334, 356, 373, 396, 436, 457, 476, 497, 516; Drainage, 115; Improvement of, 67, 87; Lectures, 333, 513  
 Zoological Society, 39, 78, 119, 219, 259, 298, 339, 379, 417, 500, 520  
 "Zoology," by Alfred Newton, F.R.S., 305  
 Zoology, Museum of Comparative, 175



# NATURE

A WEEKLY ILLUSTRATED JOURNAL OF SCIENCE

*"To the solid ground  
Of Nature trusts the mind which builds for aye."*—WORDSWORTH

THURSDAY, NOVEMBER 5, 1874

## THE PROSPECTS OF THE ENDOWMENT OF RESEARCH

WITH this number a new volume of NATURE is commenced, and consequently it will not be inappropriate to take the opportunity of presenting some sort of review of the present position of a subject towards which we have always been ready to devote much of our space. We propose to show that the important evidence given before the Royal Commission on the Advancement of Science, and the Reports which that Commission has already issued, have not been without influence in the matter, whilst the publication of the Report of the University Commissioners renders it the more necessary not to relax our efforts in pressing this question continually upon the public. It is most encouraging also to notice as another symptom that ordinary opinion is gradually coming round to the views we have so long advocated, that the daily and weekly press have during the past month opened their columns to articles and correspondence on this subject, and that journalists no longer regard the proposal to endow scientific research as a visionary and wild scheme, but now consider it worthy of much consideration and intelligent criticism. Even at the Universities considerable progress in the right direction seems to have been made, which is the more deserving of attention when it is recollected that the Colleges have in most cases great constitutional difficulties to overcome before that they can carry into execution the smallest reform.

At the end of the first volume of the Report of the University Commissioners there is printed in the Appendix a comprehensive scheme for a redistribution of their revenues, which has in principle been unanimously adopted by the governing body of New College, Oxford. It represents a plan of reform, the most fundamental in its principles and the most elaborate in its details which has yet been offered to the public; and shows in all its features how willing the more enlightened Colleges are to adapt themselves to modern requirements. The date of the adoption of the report of a select committee embody-

ing this scheme is October 8, 1873, and the contents of the report prove no less certainly than the date of its adoption that the labours of the Royal Commission on the Advancement of Science have not been thrown away. "The encouragement of mature learning, as distinct from teaching," is expressly recognised as one of the four objects which College Fellowships should serve; and accordingly, "this purpose is met by providing for the election to Fellowships, and for the retention in Fellowships, of persons who have given proof of real interest and aptitude in literary or scientific studies." These Fellowships are elsewhere described as "held merely on the general condition of study," and the election may be without examination in the case of a person already eminent in literature or science. All the Fellowships to which no educational or bursarial duties are attached are limited to a period of seven years, and the proposed emolument is 200*l.* per annum; but "the College shall have power to re-elect once or more times, for periods of seven years, any Fellow who is engaged in literary or scientific study, which is likely to produce results of permanent value in published writings." These proposals form part of a scheme in which the College committee dispose in various ways of a total annual sum of 16,000*l.*, at which amount they estimate their divisible revenue at the end of the present century; and though there may be several details in the entire scheme which suggest criticism, yet New College will always deserve a high meed of praise for being the first college to break through the ancient traditions which have hitherto prevented the corporate revenues of these institutions from being directly utilised for objects disconnected with education. The revised statutes of University College, which have been approved by her Majesty in Council, also deserve notice in that they reserve power to the College to elect to a Fellowship without examination "any person of special eminence in literature, science, or art." It is true that this clause is merely a modification of one which already occupies a place in the ordinances of the majority of the Oxford Colleges, which gives the same power, with the proviso that such person shall have received an honorary degree from the Convocation of the University. But as this clause has never yet, to our knowledge, been acted upon, the necessary inference is that the proviso, which

appears sound in principle, is found in practice an insuperable obstacle. It may here be noticed that the revised statutes of Balliol, to which College the outside world is wont to look as the leader in all reform, ordain that all Fellowships shall be filled up after examination, except only in the case of University Professors, or persons eminently qualified to be college tutors. It does not appear from the Report of the Commission that the Cambridge Colleges have yet taken any steps to appropriate definitely any portion of their endowments to the encouragement of scientific research; but it is a matter of common notoriety that at the October election to Fellowships at Trinity College, a candidate was successful whose chief qualification was that he had already accomplished good original work in embryological investigation; and Cambridge men may therefore boast that this one fact is worth all the schemes of the sister University. Both Oxford and Cambridge, however, will have to do much more than they have yet attempted, or than most of their members would appear to have yet conceived, before they can satisfy the public wants and justify the retention of their wealth as it now stands disclosed.

In other respects also we are glad to observe that the objections to the endowment of research are growing less numerous and less violent, and that the details of a scheme by which this object may be furthered are becoming more acceptable to the general public. The question was brought into prominence by an article in the last number of the *Fortnightly Review*, and the writer of that article has not been slow to strengthen his positions and answer all opponents in the daily and the weekly press. We must confess that we have been fairly surprised to see with what general acceptance his thoroughgoing views have been met, and they merely require the approval of persons eminent in their particular sciences in order that they may carry conviction to all impartial minds. The evening organ of the Conservative party concludes a notice of them with the following judicious sentence, which could not have been written a bare twelvemonth ago:—"The general principle of the need of some sort of endowment for science is generally admitted, and in the main features of the scheme there is much to recommend it to a prudent public." The remaining evening papers, which have all called attention to the scheme, are, if not so laudatory, at least critical rather than hostile; for the time seems to have passed when the matter can be thought deserving of being laughed down with a sneer. We feel bound to refer more particularly to a letter contained in the *Spectator* of October 24, written by the gentleman referred to above, and entitled, "A Draft Scheme for Endowing Research." The intention of the letter is to show that it is practicable, by means of a judicious application of precarious salaries, to train up a class of scientific investigators, and that it is a safe investment to give endowments to young men before they have reached eminence in their studies. This point deserves the more attention because it appears to be now widely granted that sinecure posts ought to be provided for men of science who are already famous for their discoveries, and for this latter object the Colleges have at present sufficient power, if only the will also were there. The essence of this draft scheme is to be found in the principle, at once comprehensive and

simple, that no candidate is to establish his claim to a permanent endowment until he has previously served an apprenticeship of some ten years, during which period he must furnish continual proofs of his aptitude and diligence, and will receive regular payment by results amounting to a continuous salary if his work is satisfactory. The candidates would be originally selected on the nomination of the professor under whom they have studied, tempered by a moderate examination to exclude manifest incompetence; and during their long period of probation they will be continually liable to rejection, if it be found by the board to which this duty is entrusted that they are not worth the money they are receiving. This plan, no doubt, is well worthy of trial at a central University, where the prolonged course of study under the superintendence of professors naturally lends itself to its adoption, and it could scarcely be perverted to greater wastefulness than at present characterises the Fellowship system at Oxford and Cambridge. It may, however, be plausibly suggested that something less elaborate in system and more closely adapted to the wants of specific studies would be required in the pecuniary encouragement of research which it is the duty of the nation, independently of the Universities, to undertake.

#### GRESHAM COLLEGE

IN the previous article we speak of the advancement of scientific research, and here we wish to refer to an excellent article in Monday's *Daily News* connected with the advancement of education. The misuse and idleness of the untold wealth of the London City Companies we have frequently referred to; but until the *Daily News* unearthed the facts contained in its article, few people were aware of the existence of an institution which is one of the most striking anachronisms of our time, and the uselessness of whose endowments is provoking, now that the importance of scientific education to all classes is beginning to be keenly felt, and when its progress is so much hampered by want of means. The writer in the *Daily News* deserves the greatest credit for the trouble he must have put himself to in obtaining the facts about the institution known as "Gresham College," and for the uncompromising way in which he has stated the facts of the case. It is indeed a hopeful sign of the recognised importance of sound scientific teaching, when the daily press espouses its cause so heartily.

The *Daily News* article begins by referring to the admirable system of lectures to working men during the winter at South Kensington in connection with the School of Mines, and which are so popular that many are shut out from want of room in the lecture theatre. Each Professor now gives a course of six lectures in alternate years, an average of twenty-four lectures being thus given in the course of the year, in the plainest English, by Professors of the first rank, for the nominal fee of one penny per lecture. "More thronged, more silent, or more attentive audiences," to quote the *Daily News* article, "than those which attend these lectures to working men it would be impossible to find, even in the halls of the most learned of learned societies." This, combined with the results of some of the examinations in the Science and Art Department, seems to us to prove the readiness and eagerness

of working men to take advantage of instruction in science when there is some guarantee that such instruction is sound and earnest; and it is a pity, when this is the case, that any time should be lost in devising some system of scientific and technical education suited for the wants of the whole country. At all events the pabulum provided at Gresham College is a sad mockery of this widespread craving for knowledge. Again, to quote the writer in the *Daily News*: "While the West is thus enlightened by modern science, in the East a phantasm bedizened in the worn-out rags and tatters of scholasticism provokes contemptuous laughter. In the large lecture theatre which occupies the greater part of the building at the corner of Gresham and Basinghall streets, to an audience composed of perhaps half a dozen persons, who have drifted in from mere idle curiosity, an English divine will read a lecture on astronomy in the Latin tongue, followed an hour later by an English lecture but little better attended. This, with similar curious exhibitions during Term time, is the outcome of Sir Thomas Gresham's bequest, and the functions of those who were once resident Professors have dwindled to the delivery of these almost unattended lectures." The writer then goes on to tell the melancholy history of the Gresham Fund, and he tells it so well that we shall give the story nearly in his own words.

"The atrophy of Gresham College is well worthy of notice. By the will of Sir Thomas Gresham, the great merchant of Elizabeth's time, and the Founder of the Royal Exchange, were bequeathed, in moieties to the City and Corporation of London and to the Company of Mercers, under certain conditions, 'the buildings in London called the Royal Exchange, and all pawns and shops, cellars, vaults, messuages and tenements, adjoining to the said Royal Exchange.' To the foundation of a college, 'myne now dwelling-house in the parish of St. Helens in Bishopsgate and St. Peters the Poor' was devoted, and the 'Mayor and Commonalty' of the City of London were charged with 'the sustentation, maintenance, and finding' of four persons to read lectures on Divinity, Astronomy, Music, and Geometry in the said dwelling-house—a stately mansion. The Company of Mercers was charged with the maintenance of three Professors to lecture on Law, Physic, and Rhetoric, and on both the City and the Company of Mercers was enjoined the performance of sundry charitable duties towards almsmen, poor prisoners, and the like. Celibacy was pronounced an absolute condition of professorship, and the seven lecturers were to reside in 'myne now dwelling-house,' and were each to receive fifty pounds yearly—no inconsiderable remuneration in the year of grace 1575, when good Sir Thomas set his 'seal with the grasshopper' to his last will and testament." For a considerable period after the founder's death Gresham College appears to have remained an important institution. Here, on Nov. 28, 1660, the foundation of the Royal Society was decided upon by a knot of philosophers who had assembled to listen to a lecture on astronomy by Christopher Wren, at that time a resident Professor in the old Gresham Mansion, where the chair of Geometry was filled by the celebrated Hooke. Escaping the Great Fire of London, Gresham College, still a flourishing institution, served for a while as Guildhall and Exchange to what was left of the

City, but within the following forty years fell into that decadence from which it has never since emerged. In 1706 a memorial was laid before the Lord Mayor and the Court of Aldermen, setting forth grave causes of complaint against the Professors. A dashing pamphleteer of the period also declared that the Professors, albeit "gentlemen of civility, ingenuity, and candour," yet seemed to discover an "unwillingness and reluctance to perform their work, because it required some pains and attendance, and were so far from the ambition of being crowded with auditors that they seemed rather to desire to have none at all."

"This state of things was bad enough," continues the writer in the *Daily News*, "but worse was to follow. In 1768, with the consent of the Grand Committee of the Gresham Trust—which consisted then, as now, of four aldermen and eight commoners of the City of London, and twelve commoners for the Company of Mercers—the Gresham Mansion and the site on which it was built were alienated to the Crown for the purpose of building a new Excise Office. 'Myne dwelling-house' had been scandalously neglected, and allowed to fall into such a dilapidated condition that its unworthy guardians parted with it in consideration of the payment to the City and the Mercers' Company of a perpetual rent of 500*l.* per annum, the City and Company paying 1,800*l.* down towards the cost of pulling down the ancient building and erecting the new office. By this transaction an estate of great value was sacrificed, the handsomest house in London torn down, and the collegiate establishment entirely subverted. A room at the Royal Exchange was set apart for reading the lectures, celibacy was no longer made a condition of professorship, and residence was dispensed with as a matter of course—the lecturers being each allowed 50*l.* yearly, in lieu of apartments, over and above the original salary of 50*l.* Owing partly to the incapacity of the Professors and partly to the inconvenient hours at which the lectures were delivered, the attendance of the public diminished, until between the years 1800 and 1820 the average number of the audience was only ten at each English lecture and thirteen at all the Latin lectures for the whole year. On the burning of the Royal Exchange Gresham College became a nomad institution, the lectures being mumbled or gabbled over in any hole or corner, until 1841, when the Gresham Committee purchased the present site, and erected on it a handsome lecture theatre at a cost of 7,000*l.* On various occasions attempts have been made to modify the constitution of Gresham College; but although it was found possible to entirely overturn the provisions of the 'pious founder' in 1768, all subsequent interference has been met by the most determined opposition. It will hardly be credited that a prolonged struggle ensued before the Professors could be brought to issue a syllabus of the lectures to be delivered in each term. Still greater difficulty was experienced in transferring the hours of lecturing to the evening. This innovation was firmly resisted, and it was only by waiting till the tough old irreconcilables were gathered to their fathers that it was at last carried out.

"Very slight improvement has taken place under the new order of things. Shortly before six o'clock on the evenings designated in the syllabus the doors of Gresham College are opened, and a superb beadle looks out to see

if any human being will be weak enough to enter the hall of dulness. As the clock hands closely approach the hour a thrill of excitement passes through the lecturer and the beadle. Two misguided persons have strayed into the building, and on the arrival of a third depends the reading of the Latin lecture, which is not delivered to a smaller audience than three. Should the third unwelcome guest put in an appearance the deed must be done—the lecturer must make a show of earning the 4*l.* 3*s.* 4*d.* he gets for reading the Latin discourse. Looking rather flustered—perhaps by the consciousness that three wicked wags have conspired to make him work—he opens a well-dog-scarred manuscript, and, reading at a tremendous pace, dashes through a composition which, as a rule, sets criticism at defiance. The good old traditional policy of driving auditors away is well kept up. Long Greek quotations loosely patched together by a rigmarole of doubtful Latinity, and rattled over with an evident intention of getting to the final *àdixi* as quickly as possible, are not calculated to enchain the attention of a modern audience. It is only fair to admit that the lecturer sometimes shows a keen appreciation of the dreary farce in which he is the chief actor, and on these occasions condescends to address a few words—in English—to such of the audience as may be ‘in at the death.’ Feeling that a lecture in Latin needs not, therefore, be either tedious, stupid, or confused, he acknowledges the miserable quality of the rubbish he has just rattled through, and excuses it on the ground that the attendance is not sufficiently great to encourage the production of a good lecture; adding, moreover, that if more people came more pains would be taken. This solemn mockery is repeated every term, so that if all the Latin lectures were read, the majority of the professors would each deliver twelve English and twelve Latin discourses for his 100*l.* per annum—by no means an excessive rate of payment if the lectures really instructed anybody in anything. Unfortunately, as at present conducted, Gresham College is utterly and completely useless to any human being save only the professors and the beadles, who draw their salaries with commendable punctuality. Another matter for regret is, that not only is the use of a commodious building lost, but that a collection of books, which if placed in the City Library would be accessible to students, lies buried in the unprofitable seclusion of the College. If the Gresham Committee take no interest in the important trust confided to them, it is indeed high time that public attention was directed to an antiquated and transparent sham, a disgrace alike to the age and to the city in which it is perpetrated.”

We hope that this unsparing exposure will lead to an inquiry into the abuse, and an appropriation of the valuable funds to a purpose much more consistent with the spirit of the will of the benevolent and well-meaning founder.

#### HECKEL'S DEVELOPMENT OF MAN

*Anthropogenie oder Entwicklungsgeschichte des Menschen; gemeinverständliche wissenschaftliche Vorträge*, von Ernst Hæckel. (Leipzig: Engelmann, 1874.)

THE new volume of so-called popular lectures by Prof. Hæckel bears somewhat the same relation to “The Descent of Man” which his “Schöpfungsgeschichte”

did to “The Origin of Species.” Few who are acquainted with Mr. Darwin's writings will agree with the criticism lately put forth from the chair of the British Association that they need an expounder. Those, however, who are dissatisfied with his patient analysis of facts and sober deduction of principles will find abundant exposition and extension in such works of his disciples as “The Beginnings of Life,” “The History of Creation,” and the present volume.

In criticising the vast system of dogmatic cosmogony which is here built up in lectures before a popular audience, one would not for a moment confound it with the flippant confidence of sciolists who attack or defend the theory of evolution, not on its scientific merits, but because it seems to them to support some theological or antitheological prejudice. But it is a matter of deep concern that so justly eminent a biologist as Prof. Hæckel should allow himself, in treating a subject which above all demands the dry light of impartial judgment, to adopt the style of those “who are not of his school—or any school.”

The fact is, that the extremely difficult subject of the philogeny of man, demanding an accurate knowledge of embryology and comparative anatomy, both recent and fossil, is not at all fitted for popular treatment. Popularising science ought to mean persuading people to work at some of its branches until they learn to love it, not altering its character so as to make it please the itching ears of idlers.

The really valuable parts of the “Schöpfungsgeschichte” and the “Anthropogenie” must be at once useless and distasteful to such readers; and if they accept all the “advanced” theories laid out and dried before them, they will be learning a bad lesson in biology. If they happen to have one set of prejudices, they will denounce all science as an invention of the devil; or if they have another, they will degrade it into a mere instrument to insult the feelings of their neighbours. Prof. Hæckel assures his hearers that the history of development contains more valuable knowledge than most sciences and all revelations; but, whether more or less important, the secrets of nature, like those of revelation, can only be gradually learned with patient ear and reverent spirit: they are meaningless or mischievous when accepted without pains or preparation.

Unfortunately, in these lectures the teacher frankly drops the character of the student of nature and assumes that of the combatant. Even in the preface he attacks the “black International” of Rome, “jener unheilbrütender Schaar,” with which “at last—at last the spiritual war has begun.” We see “the banners unfurled,” we hear “the trumpets blown, which muster the hosts for this gigantic struggle.” We are shown “whole ranks of dualistic fallacies falling before the chain-shot of monistic artillery, and libraries of Kirchenweisheit and Aferphilosophie (*sic*) melting into nothing before the sun of the History of Development.” But when these metaphors are dropt, we find that the objects of this gigantic strife are to prevent certain (unspecified) teaching in primary schools, to suppress convents and celibacy by law, to expunge Sundays and saints' days from the calendar, and to forbid religious processions in the streets!

After this extraordinary preface, Prof. Hæckel enters on the more serious part of the book by a history of the doctrine of development. Passing rapidly from Aristotle and the founders of biology in the sixteenth and seventeenth centuries, he describes at some length the discoveries of Wolff (published in 1759), which were so long and so unjustly neglected; the scarcely less splendid researches of the now venerable Von Baer (1827), and those of Mr. Darwin, from the appearance of the "Origin of Species" in 1859 to the present time. Among the ontogenists, beside Wolff and Von Baer, whom he justly places in the first rank, due mention is made of Pander, Rathke, Bischoff, Johannes Müller, Kölliker, Remak, Fritz Müller, and Kowalevsky. But while most English embryologists (and histologists too) will probably agree in substance with our author's judgment on the doctrines of Reichert and of His, they would scarcely speak of a distinguished living anatomist as "dieser, auserordentlich unklare und wiiste Kopf." Among the philogenists who preceded Darwin, particular attention is paid to the speculations of Lamarck, in his "Philosophie Zoologique," which were published in 1809, and thus exactly divided the century which elapsed between the first great work on the subject, Wolff's "Theoria generationis," and the last, Darwin's "Origin of Species;" and also to those of Goethe, extracts from whose writings, both prose and verse, are scattered up and down the volume, not only in the text, but on the fly-leaves and other blank spaces. We venture to think that both here and elsewhere Prof. Hæckel has put too high a value on these pre-Darwinian speculations. He discovers who proves; and neither Lamarck nor Goethe could justify their guesses by facts. They happened to be right, just as among all the random guesses of the ancient Greek cosmologists Thales happened to have hit on the true relation of the sun to the earth, probably from his being less and not more philosophical than his fellows. If some of the assertions of modern spiritualists or phrenologists should hereafter turn out to be true, they would no less deserve the condemnation of a future generation for believing what, on the facts within their knowledge, they had no business to believe.

The chapters which succeed are devoted to a clear and tolerably full account of the development of the human embryo from the ovum-cell to the stratification of the blastoderm. The only fault to find with this part of the book (and its merits need no praise for those who are acquainted with our author's skill in exposition of a difficult subject) is the exaggeration of such phrases as this: "The process of fecundation is very simple, and involves nothing at all peculiarly mysterious." In one sense, of course, this is true; the ultimate mystery of every function, organic or inorganic, is equal: but fecundation, like other organic functions, has the peculiar mystery that we cannot yet rank it with other mysteries. Most of us believe that one day each movement of each particle of the ovum will receive its appropriate physical explanation, but till then we must be content to call them vital, just as we call other movements chemical: and even a popular lecture should not anticipate the advance of science.

The most important position maintained in this part of the book is that in Vertebrata the two primitive blasto-

dermic layers (epiblast and hypoblast of Huxley, exoderm and entoderm) differentiate each into two, as in Vermes, and that the mesoblast (motorgerminal layer of Remak) subsequently arises by coalescence of Von Baer's Fleischschicht or Hautfaserblatt and Gefässschicht or Darmfaserblatt. The various opinions which have been put forth on this difficult subject are discussed, and the author's view illustrated by some coloured figures. In the number of the *Quarterly Microscopical Journal* for last April there is an article by Prof. Hæckel (very ill-translated) on the "Gastræa" theory which was put forth in his valuable work on "Calcareous Sponges;" and there he discusses the homologies of the secondary germ-layers. To it we may refer the English reader as an exposition of this part of the subject, and unfortunately as another instance in justification of what has been said of the dogmatic confidence and undignified personalities which disfigure the present volume.

The description of the further development of the human embryo, including a short account of the origin of the various organs, is an excellent example of how a very complicated subject may be explained and illustrated. The figures from Bischoff, Kölliker, Gegenbaur, and other anatomists are somewhat coarsely reproduced, but are supplemented by some new drawings on stone. These chapters, however, on human ontogeny and organogeny are unexceptionable and somewhat commonplace. They seem to be chiefly introduced for the sake of the philogeny which occupies the third series of lectures. It is the close connection between the known development of the individual and the hypothetical development of the race which it is the merit or demerit of the book to expound to a popular audience, and to this subject we hope to refer in a future article.

#### LETTERS TO THE EDITOR

[The Editor does not hold himself responsible for opinions expressed by his correspondents. Neither can he undertake to return, or to correspond with the writers of, rejected manuscripts. No notice is taken of anonymous communications.]

#### Migration of Birds

I HAVE to thank Mr. Wallace and Mr. Romanes for their remarks (NATURE, vol. x. pp. 459 and 520) on the article in which I drew attention to this subject. The former especially has laid all ornithologists under an obligation for the characteristic skill with which he has illustrated the way whereby migratory habits have most likely been brought about. I think it is very possible, as he suggests, "that every gradation still exists in various parts of the world, from a complete coincidence to a complete separation of the breeding and subsistence areas," and that "we may find every link between species which never leave a restricted area in which they breed and live the whole year round, to those other cases in which the areas are absolutely separated." Still, I cannot point out any species which I believe to be, as a species, strictly non-migratory. No doubt many persons would at first be inclined to name half a dozen or more which are unquestionably resident with us during the whole year, and even inhabit the same very limited spot. But I think that more careful observation of the birds which are about us, to say nothing of an examination of the writings of foreign observers, will show that none of them are entirely free from the migratory impulse. Perhaps the nearest approach, among British birds, to an absolutely non-migrant may be found in our familiar Hedge Sparrow. Personally, I have never been able to detect any movement in this bird, but one has only to turn to works on the ornithology of the extreme north and south of Europe to see that it is affected like the rest, and even in the Orkneys it is described as an occasional autumnal visitant. However, in most of the

British Islands and the more temperate parts of Europe it is very possibly only the young of this species which migrate, and the adults, having once fixed on a place of residence, may stick to it; so that here we have a case which will almost bear out Mr. Wallace's supposition. With this, however, he stops, and I am sorry to say offers no suggestion as to the way in which migration is effected.

The question which Mr. Romanes puts would be more appropriately answered by Mr. Tegetmeier, and I hope he will be induced to do so. I can only say that that gentleman has repeatedly urged his views on me in conversation and upon the public in his books (see "Pigeons, their Structure," &c., pp. 84, 85, and "The Homing or Carrier Pigeon," pp. 37-42, 105-118) which, being ready of access, I need not here quote. To limit myself to what I am alone answerable for, I would say that when declaring that sight alone cannot be much aid to birds while migrating, I had especially in mind the almost peculiar case of the Scandinavian form of Bluetit (*Ruticilla svecica*), which winters in Egypt and the Nile Valley, and summers in the northern or mountainous parts of Sweden, Norway, Finland, and Russia; while, though no doubt passing regularly twice a year over the intervening countries of Europe, it is there so singularly scarce as to have been, until of late years, almost unknown to the best of German ornithologists. For the benefit of such of my readers as are unacquainted with the bird, I may add that the cock has a conspicuous and beautiful plumage, a fine song, and habits which, in the spring of the year, cannot be called unobtrusive. If, therefore, it did commonly occur in Germany—where I should state that a kindred form (*Ruticilla leucoccyana*) is very well known—it could not escape observation. Wonderful as the feat looks, it would therefore seem as though this Scandinavian Bluetit passed over Europe at a stretch, and if so, I cannot conceive its flight being guided by any landmarks.

Furthermore, there is ground for believing that some of the migrations of many species, particularly of water-birds, are performed at night, when sight, one would think, can be of little use to them. But, to be honest, I must confess that dark, cloudy nights seem to disconcert the travellers. On such nights the attention of others besides myself has often been directed to the cries of a mixed multitude of birds hovering over this and other towns, apparently at a loss whether to proceed, and attracted by the light of the street-lamps.

One other point only need I now mention; this is Mr. Romanes's assertion that "in the case of all migratory birds, the younger generations fly in company with the older ones," which is at variance with a statement (hitherto, I believe, uncontroverted) of Temminck's:—"On peut pour un fait que les jeunes et les vieux voyagent toujours séparément, le plus souvent par les routes différentes." (Man. d'Orn. ed. 2, iii. Introduction, p. xliii. note.)

ALFRED NEWTON

Magdalene College, Cambridge, Nov. 2

#### Insects and the Colours of Flowers

THERE is one point connected with Mr. Darwin's explanation of the bright colours of flowers which I have never seen referred to. The assumed attractiveness of bright colours to insects would appear to involve the supposition that the colour-vision of insects is approximately the same as our own. Surely this is a good deal to take for granted, when it is known that even among ourselves colour-vision varies greatly, and that no inconsiderable number of persons exist to whom, for example, the red of the scarlet geranium is no bright colour at all, but almost a match with the leaves.

RAYLEIGH

Whittinghame, Preston Kirk

#### Sounding and Sensitive Flames

A SEVERE indisposition, which disabled me from correspondence during nearly the whole of last month, prevented me from acknowledging as soon as it appeared in NATURE (vol. x. p. 244) Prof. Barrett's excellent communication on Sounding and Sensitive Flames, replying to my letter on the same subject at page 233 of this volume. Prof. Barrett supplied me with many useful references, and with one at least the want of which led me to misrepresent his connection with the discovery of sensitive properties in suitably adjusted wire-gauze flames, for which I had sought in magazines and journals for some months previously in vain. A note of the original description of Mr. Barry's experiment in NATURE, vol. v. p. 30, had in the meantime been pointed out to

me in another record of very similar experiments, which is itself also, I have no doubt, the same account of "further experiments with the same kind of flame," that Prof. Barrett cites as appearing in the *Journal of the Franklin Institute* for April 1872, to which I have not been able to obtain access. The nearer channel to which I was referred for its perusal is the *Philosophical Magazine* for June 1872, where a paper is briefly extracted from the *American Journal of Science* of the preceding month, describing new experiments with Barry's sensitive flame, by Mr. W. E. Geyer, of the Stevens Institute of Technology, in the United States. By placing a wide tube over the flame at a proper height it became sounding, or, if silent, might be made sensitive in such a way as to sound at the slightest hiss or rustle, and on producing any jingling or tinkling sounds in its neighbourhood. Thus the flame sounded twice on pronouncing to it the word "sensitive," showing its instantaneous affection even by momentary sibilant sounds. By varying the experiment, an opposite condition of the flame was obtained, in which it continued sounding until checked by a hiss or rustle from without. It is observed by the editor of the *American Journal of Science*, in a note to Mr. Geyer's paper, that in the number for September 1871, of the *Moniteur Scientifique*, a form of apparatus and experiment apparently identical with Mr. Barry's is noticed as having been made by Prof. Govi at Turin, and this was a few months prior to the letter in which the account of his experiments is given by Mr. Barry to Prof. Tyndall. Thus the sensitive properties of certain wire-gauze flames, like the property of such flames to excite very readily musical vibrations, may have had many independent discoverers; and the value of such discoveries is now, as it must have ever been, the new light which one is capable of throwing upon another. The rapid publication of results urgently requires their frequent collection and comparison together; and this process, pressing and urgent as it is, seldom fails in experienced hands to prove a connection, to bind together a chain of consequences, and to leave a subject in general better explored and embellished with new-found illustrations than it was before. Such was the successful treatment, a few years ago, by Prof. Tyndall, of the question of sounding and sensitive flames, when it was shown by beautiful illustrations of Savart's sensitive water-jets, and by equally ingenious and new experiments with smoke-jets as substitutes for flames, that sensitiveness is a residing property of liquid veins and gas-jets, independently, in the latter case, of their being lighted. The laws of fluid pressure and motion, and apparently foremost of all those of capillary attraction in liquids and of mutual friction and diffusion in gases, and not the energies of heat and combustion of a flame, preside principally over the observed phenomena. The bifurcated head, or low ruffled brush to which the tall wand-like sensitive jet is suddenly reduced, is but the glowing representation of the form which, if it were visible to the eye, the unlighted jet would, under the same circumstances, be observed to take. This is at least in general terms, and perhaps also in plain and fairly accurate statement of the real facts, the simple result which the collection and elucidation of the most brilliant then known experiments illustrating sensitive flames, led a philosopher of Prof. Tyndall's enlightened sagacity and skill in physical investigations to adopt. There can be no doubt of its substantial correctness in the increasing array of cases to which it may be successfully applied. The flame is but an illuminated effigy of some of the lowest parts of the issuing gas column, whether tranquil or disturbed, whose upper parts it removes and replaces by products of combustion. The lower parts are also marred in their form by heat, but not so much as to obliterate the original character, shape, and dimensions of the part of the gas column that it represents. The flame terminates upwards, and ceases to represent the unlighted column further when it has found surface of contact enough with the outer air to effect the complete combustion of the gas. The up-draught of violently heated products of combustion near the base impedes the access of fresh air to parts near the summit of the flame, and it must, besides, deform them otherwise, sometimes even rhythmically, as in the unsteady throbbing flame of an ill-trimmed lamp or of a candle burning in its socket. The noisy roar with which flaring of gas-flames is attended tells us also of the uneven mixture of the gas and air supplies with each other in the flame, and reminds us of the rapid fire of small explosions that most probably introduce new sources of confusion in its form. If these explosions, however, are regularly timed, they can be made to maintain the simple musical note of harmonic flames; and these flames again, wholly dependent as they appear to be

on their combustion for the musical sounds that they emit, must, it appears from Count Schaffgöth's and Prof. Tyndall's well-known experiments, when placed in certain circumstances of silence and indifference in an open tube, be aided by the voice at a distance to commence their song. The signal-note first raises certain mechanical vibrations in the gas-current of the narrow jet, that are necessary in the outset to produce commotions enough of the singing flame to make it able to continue and maintain them. The sensitive sounding-flame of Mr. Geyer bears a similar explanation, for not being regularly adjusted, although very nearly so, to continued sounding, a rustle sufficient to flurry the sensitive wire-gauze flame under the open tube creates in it so many brisk explosions, that the resonance of the sounding-tube is excited, and is at once exalted to a loud note by the rhythmical expansions of the flame; but with the cessation of the external sound the maintaining impulse ceases, and the wire-gauze flame whose commotions must be kept up in order to maintain the note immediately becomes as silent as before.

It is remarkable that the gas-pressure used to obtain Barry's sensitive flame is not sufficient to produce visible sensitiveness in the taper-jet alone; but if the gauze is raised and lowered over the unlighted jet, a proper position is soon found where the cone of blue flame burning on the gauze above possesses a very high degree of sensibility. The use of smoke-jets instead of flames in this arrangement would perhaps give more positive proofs than may yet have been obtained of the cause of the impressibility. It appears, however, scarcely probable that in the short space of a few inches from the aperture the pin-hole current of unlighted gas can increase its amount of air-mixture so much by the influence of external sounds, that this would account sufficiently for the descent of the conical gauze-flame from the pretty stately eminence of a tall and steadily-burning hill top, to little more than the elevation of a stormy bed of low struggling and bustling flame. The alternative supposition is that the disturbance commences in the meshes of the gauze itself, and that it extends upwards from them with such rapidly increasing agitation that a perfect mixture of the gas-current with the surrounding air, and its complete combustion, are thus enabled to take place at very short distances above the gauze.

I have been led to offer these few reflections on some of the most remarkable examples of sensitive and sounding flames from a wish to distinguish in their action as well as possible between the part which purely mechanical forces, and that which the operations of heat and combustion play separately in their production. The mechanical part of the explanation appears to consist in supposing the sensitive jet, when it is properly adjusted, as being in a state either bordering upon, or of actually existing undulation. The hissing sound of all air-jets, if listened for attentively enough, is a proof of the reality of the disturbance; and such sounds, it has been suggested by Sir G. Airy, indicate disruptions of continuity in the air round the nozzle of the jet, arising, no doubt, from the rapidity with which particles of the quiescent external air are there carried off by friction with the gas-current of the jet. It is hardly possible that *vacua* so complete (when they exist) should fail to supply the jet with a succession of smoke-rings encircling it and probably travelling up the jet with different speeds according to their magnitude and the depth to which they are involved in the upward current of the gas. If a disposition to regular periodic action exists in the jet (and the smoother its orifice, and the more steady the supply of gas to the jet, the more probable this appears to be), a succession of smoke-rings\* of the same size, and of greater or less strength according to the uniform pressure of the gas, may easily be supposed to course each other up the flame, and being gradually consumed in ascending, to leave its tall column to the top with sides as smooth and even as a rod of glass. But if the gas-pressure is much increased, a phenomenon like that of companion cyclones observed in rotating storms, perhaps presents itself at the orifice of the jet, each strong smoke-ring as it is formed being

probably followed by a weaker one (a residual offset from the first) travelling after it with less velocity on the outer surface of the flame. The companion rings are probably overtaken and destroyed at a certain height in the flame by the next following strong ring, and the succession being continuous, a puff at a certain height in the flame, where the companion rings collapse, throws it there into a permanent excrescence or confusion. Both rings may be broken by the shock, and if of oval forms, as they must probably be in some jets, the two projecting halves of the stronger ring when struck, on springing outwards may thus appear to divide the flame at a certain height above the jet into two pointed tongues forking outwards from each other to a certain width. This form of sensitive flame was shown to be readily obtainable by Prof. Barrett by means of a tapering glass quill-tube jet, the edges of which on two opposite sides are slightly ground or snipped away into a V-shaped notch. Besides the secondary or companion ring, tertiary and higher orders of following rings may possibly be formed; and each strong primary ring may have to run the gauntlet of several weaker antagonists before it at last emerges safely, or else is destroyed itself in its conflicts with them. The flame is lowered to a bushy head in the latter case; but if the primaries outlive their shocks, and if, as might sometimes happen also, the secondaries alone survive, it seems possible that a sensitive flame with a short continuation of steady flame overtopping the region of tumult and confusion, could in this way be obtained. The hypothesis seems equally applicable to gauze flames, as nothing can prevent smoke-rings after smoke-rings from rolling up the contiguous sides of parallel jets nearly in contact with each other. Indeed, the difficulty of access of the outer air to the spaces between the jets must favour the production of *vacua* round the orifices, and accordingly the occurrence of air-whirls. This is perhaps the reason why wire-gauze flames begin to show sensitive properties at gas-pressures so much lower than those found necessary in the case of a single flame burning at a taper jet. The whole array of jets, it may be, in a wire-gauze flame behaves very nearly alike, and the flame as a body burns, whether noisily or silently, in the same manner, but with greatly increased susceptibility, as a single flame-jet from one of the gauze-meshes alone would appear to do. Whatever mechanical distinction may really exist between the mode of action of the common taper jet and the wire-gauze sensitive flames, it appears, therefore, rather to be one of a higher degree of susceptibility at low pressures, than of any more distantly distinct or special kind. Even the mode of operation of external sounds upon them is probably very similar in the two cases, for by rapid vibrations of the external air, such as a hiss or shrill whistle produces, the gas-jet leaving an orifice is shifted bodily to and fro over its edges, and nothing can more certainly produce partial *vacua*, and consequently air-whirls round its circumference, than sudden displacements of an air-jet laterally over the sides of its aperture, even if the tendency to develop them more or less periodically did not exist already in the critical or "sensitive" condition of the jet. Axial vibrations, also, or those impressed by outer disturbances on the gas current in the orifice in the direction of its flow, cannot be altogether without effect in producing *vacua* and air-whirls at its mouth; and among the multitudes of them thus occurring from the impressed action of external vibrations in all directions, a rhythmical selection is probably made depending on the form of the burner and the pressure of the gas. It is difficult to imagine how the partial air-vacuum or aspiration constantly existing round the nozzles of blast-apertures can bestow its energy when broken into discontinuity, rhythmical or otherwise, by a turbulent condition of the jet otherwise than by producing, in the peculiar eddy of its position, ring-shaped vortices encircling the blast; but it is evident that few jets and nozzles can be fashioned so smoothly in their inner and outer surfaces and edges that the ring vortices will often be complete; mere fragments of rings are scattered from their sides, which, having no stability, collapse with shocks and puffs that give the roaring and blustering character to the stream. With perfectly smoothed orifices there is probably every gradation according to the pressure of the gas, from full continuity of the partial vacuum or rarefaction round the jet, abating gradually and uniformly upwards to ultimate disappearance by friction with the surrounding air, through a condition of gentle undulations of this cone of rarefaction pursuing each other up the stream with slackening strength, and finally losing themselves also by friction as before, to the case of turbulence where the rings of rarefaction are quite intermittent, and separate ring-eddies more or less distinct from each other,

\* The word "smoke-rings," as here used occasionally, is not intended to imply the presence of smoke in the jet or flame, but to denote by a familiar phrase an annular air-vortex having its rotation round a circular line or ring of lower pressure than that of the surrounding air. Such annular vortices are most easily seen in liquids by drawing a flat blade through them with its broad side in front; or, indeed, as was lately shown to me by Prof. James Thomson, who supplied me with their explanation, in a cup of tea, by drawing a spoon very gently through it. Only half of the annulus is formed, encircling the edge of the blade or spoon with a curved line of low pressure, round which the liquid spins as in a smoke-ring, and shows a little whirlpool on the surface, one at each point of intersection of the surface with the low-pressure line below it. If an or-blade is drawn rather rapidly through water, groups of two or three of these ring-vortices following each other in its track can very readily be produced.



of greater or less strength, and travelling up the stream with different speeds, take the place of the more gentle undulations. The distinction between ring-vortices and ring-shape undulations is perhaps here too strongly and improperly overdrawn, as, besides the improbability that effects so exaggerated as perfect air-whirls are really ever attained in ordinary gas-jets, the properties of the undulations that correspond to and lead up to them in ordinary currents must evidently resemble theirs in all respects, so that the deeper and stronger interior undulations move up the jet more rapidly than open and weaker exterior ones on the surface; for it seems probable that both vortices and ring-waves of strongest rarefaction will generally occur nearest to the centre or axis, and those of weakest rarefaction furthest from it, or nearer to the slow-moving outer surface of the jet. The effect of the collision and destruction of a weaker by a stronger ring-wave, when they overtake each other, is the same as that of perfect circulating whirls; the balance of pressure in one part of the circular wave being broken by a shock, it collapses in every other part, and if both waves are destroyed, the further progress of the jet is intercepted at that point, and it scatters itself in a confused cloud at the point of concurrence and disruption of the waves. The long-enduring smoke- or steam-rings often seen projected from the funnels of locomotive engines at starting, or when moving slowly and emitting separate puffs, illustrate apparently the mutual action of closely packed parallel jets like those of an ordinary gauze flame; for the impeded passage to the outer air offered by a number of such surrounding jets, just as by the funnel of the locomotive engine, favours the production of a strong vacuum round the jet-aperture or blast-pipe, and of a strong wave or steam-ring, the moment that the jet or blast takes a side-swing or a sudden leap upwards that calls the action of the partial vacuum into play. A. S. HERSCHEL

(To be continued.)

#### A New and Simple Method for making Carbon Cells and Plates for Galvanic Batteries

SOME time since a correspondent asked for an easy method to construct carbon plates. A paper of mine was read in Section A at Belfast on the subject, and as it describes a process by which any experimentalist can construct not only plates but cells of carbon, I have thought a condensed account of the process may be appropriate for your columns.

With a syrup made of equal quantities of lump-sugar and water, mix wood-charcoal in powder with about a sixth part of a light powder sold by colourmen, called vegetable black. The mixture should hang thickly on any mould dipped into it, and yet be sufficiently fluid to form itself into a smooth surface. The vegetable black considerably helps in this respect.

Moulds of the cells required are made of stiff paper, and secured by wax or shellac. A projection should be made on the top of the mould for a connecting piece. These moulds are dipped into the carbon syrup, so as to cover the outside only, and then allowed to dry. This dipping and drying is repeated until the cells are sufficiently thick. When well dried they are then buried in sand, and baked in an oven sufficiently hot to destroy the paper mould. When cleared from the sand and burnt paper the cells are soaked for some hours in dilute hydrochloric acid, and again well dried, then soaked in sugar syrup. When dry they are then packed with sand in an iron box, gradually raised to a white heat and left to cool. Should some of the cells be cracked, they need not be rejected, but covered with paper or plaster and dipped in melted paraffin.

Rods or plates of carbon can be rolled or pressed out of a similar composition, but made thicker. Carbon thus made will be found to have a good metallic ring and a brilliant fracture.

Barnstaple, Oct. 26

W. SYMONS.

#### Ingenuity in a Spider

A SPIDER constructed its web in an angle of my garden, the sides of which were attached by long threads to shrubs at the height of nearly three feet from the gravel path beneath. Being much exposed to the wind, the equinoctial gales of this autumn destroyed the web several times.

The ingenious spider now adopted the contrivance here represented. It secured a conical fragment of gravel with its larger end upwards, by two cords, one attached to each of its opposite sides, to the apex of its wedge-shaped web, and left it suspended as a moveable weight to be opposed to the effect of such gusts

of air as had destroyed the webs previously occupying the same situation.

The spider must have descended to the gravel path for this special object, and, having attached threads to a stone suited to its purpose, must have afterwards raised this by fixing itself upon the web, and pulling the weight up to a height of more than two feet from the ground, where it hung suspended by elastic cords. The excellence of the contrivance is too evident to require further comment.

Torquay, Oct. 26

JOHN TOPHAM

#### Note on the Rhynchosaurus Articeps, Owen

REFERRING lately to Prof. Owen's description of the Rhynchosaurus ("Palaeontology," p. 264), first discovered by myself in 1838-39, in the New Red Sandstone of Grinshill, near Shrewsbury, I remarked that in speaking of the ichnolites supposed to belong to this animal he says there is an "impression corresponding with the hinder part of the foot, which reminds one of a hind toe pointing backwards, and which, like the hind toe of some birds, only touched the ground." In this account nothing is said of any claw being attached to this hind toe, nor have I met with any description of a claw in other authors. I have therefore thought it worth while to mention that I possess a specimen from Grinshill that shows distinctly the impression of a straight claw pointing backwards. There is also, on the same slab, the impression of another smaller foot of only three toes with strong straight claws, which has behind it a slight impression corresponding with the hind toe of the larger footprints. It is a curious fact that the claws of the larger impression, though larger than those of the smaller footprint, are so much recurved as not to project much beyond the ends of the toes, while on another slab from Storeton there are reliefs with both straight and recurved claws, the latter giving the idea of a foot like that of the Great Antelope. In these Storeton ichnolites the hind toe exhibits no claw, nor am I sure whether certain rounded elevations represent the smaller footprint in the Grinshill specimen. Upon another slab of Storeton stone I have a mark resembling the tail-mark on the slab presented by Mr. Strickland to the Warwickshire Museum, but unfortunately the footmarks connected with it are too indistinct to decide its origin. In a third slab from Storeton, besides several impressions with straight claws, there is one three inches long, the second toe of which has a straight claw  $\frac{1}{2}$  in. in length. I have also Cheirotherium footprints with long straight claws from the same quarries.

I have put these few remarks together to fulfil the wish of Prof. Owen "to obtain the means of determining the precise modifications of the locomotive extremities of the Rhynchosaurus." Perhaps by this time this object may have been attained, for at the Congress des Savans at Paris in 1863 the discovery of two almost perfect skeletons was announced, and drawings of them were exhibited by a professor from Lyons.

T. OGIER WARD

[So far as the photographs can be deciphered, they seem to bear out the writer's statements.—ED.]

#### THE ALPINE CLUB MAP OF SWITZERLAND\*

IN NATURE, vol. vi. p. 203, we adverted to the non-existence of a map of the Alps on a scale sufficiently large for general purposes, and briefly referred to the map which was then being produced under the direction of a committee of the English Alpine Club with the view of supplying the want. This map, though not yet finished, has been recently published. Three sheets are completely finished, but the fourth is still in outline, and will be exchanged for perfect copies when the hill-shading is added.

We believe this to be, so far as it extends, the most exact map of the Alps which has yet appeared, and probably no map of its size has ever been produced in this country with more beautiful workmanship or with greater

\* The Alpine Club Map of Switzerland with parts of the neighbouring countries. Edited by R. C. Nichols, F.S.A., F.R.G.S., under the superintendence of a Committee of the Alpine Club. In four sheets. Scale 250000. (Stanford, 1874.)

elaboration of detail. We could have wished, indeed, that details had been inserted somewhat less profusely. It can never be possible in maps of the scale of this one (about one-quarter of an inch to a mile) to render, with a sufficient degree of clearness, all the minutæ which are inserted in the great Government Surveys of civilised countries; nor can it ever have been supposed that this map would do away with the necessity of smaller maps of separate districts on a larger scale. Yet we find, in the map under review, in innumerable places, a mass of details which would have been amply sufficient had it been four times its dimensions, and a consequent want of clearness which is not a little perplexing. In some places, even the fantastic passes made in late years by the followers of the high art of mountaineering have been inserted, whilst in others (in the chain of Mont Blanc, for example) they have been almost entirely omitted, simply from want of space. Thus it appears, to those who are not informed, that in some places there are a great number of such passes, and in others scarcely any, when the reverse is perhaps the case. We should have advocated, both for the sake of consistency and of clearness, the omission of all passes except those of distinct utility.

In point of clearness it must be admitted that the English Alpine Club Map is scarcely equal to the reduction of the Carte Dufour which was published last year in Switzerland,\* and this is not surprising. The authorities at Bern had to produce a simple reduction of the twenty-five sheet map of Switzerland, which was intended to be useful for general purposes, and to be issued at a low price so that it might be within the reach of everyone, and in this they have succeeded admirably. They had at their command most of the members of the staff who had been employed upon the survey, and thus had little or no difficulty in determining what to omit. This was a great advantage; for it must be obvious to all that, in reducing a map to a much smaller scale, it is more easy to determine what should be inserted than it is to know what should be left out. This simple fact, no doubt, accounts to some extent for the over-elaboration of the Alpine Club Map to which we just now referred. Its projectors also adopted the Carte Dufour as the basis of their map so far as Switzerland was concerned, but they had not the command of the very exact and minute topographical information which was possessed at Bern.

The reduced Swiss map, like the Carte Dufour, is a map of Switzerland, and for the most part stops abruptly at the frontier. The English map, however, is a map of Switzerland with parts of the neighbouring countries. It extends everywhere sixteen miles more to the south than the most southern point of the Swiss boundaries, and in some places the country which it embraces (which is not included in the Swiss map) is as much as sixty-five to seventy miles from north to south. In the north and in the west the limits of the two maps are nearly the same, but in the east the English one includes the Ortelers and several other important groups of mountains, which are not given in the Swiss one. The superficial area of the Alpine portion of the English map is altogether about one-half greater than that of the other, and the chief value of the map will be found to be in the part of it that represents this land beyond, but bordering the Swiss frontiers.

It was a comparatively easy task, notwithstanding the complicated and exceedingly elaborate nature of the engraving, to render Switzerland after the Carte Dufour. The chief difficulty in the production of the map has lain in obtaining the material necessary for its completion towards the south. When it was commenced—now nearly ten years ago—there was no map, even respectably accurate, of the chain of Mont Blanc in existence; and thence, right away to the furthest land in the east which is

included, scarcely a square league could be adopted with confidence from any published survey. Hence it was necessary not only to examine every individual mountain and valley, but absolutely to re-survey several large districts. The chain of Mont Blanc, as it appears in the Alpine Club Map, is mainly taken from the special survey of Mr. Adams Reilly;\* and so, too, is the whole of the southern side of Monte Rosa, as well as the large district bounded on the east by the Val d'Ayas, on the south by the valley of Aosta, and on the west by the valley of Valpelline.† This last-named district alone includes more than 150 square miles. The Graian Alps were in a state of hopeless confusion when Mr. R. C. Nichols took them in hand, and anyone who compares the map under notice with the best which were published previously will see what radical changes and corrections have been effected. Altogether, there is in the Alpine Club Map not less than a thousand square miles which have been entirely remodelled, and, for the most part, re-surveyed; this, moreover, being some of the most rugged and difficult country in Europe, containing numerous peaks from 12,000 ft. to 13,000 ft. elevation.

Those who have been concerned in the production of the Alpine Club Map of Switzerland have a right to be proud of their work. We have tested it in the Alps, and it has stood the scrutiny extremely well. We cordially hope, though scarcely expect, that it will prove remunerative to its publisher, and that he will be induced to complete it by adding sheets to the east and to the west, so that at length there may be at least one map of the grandest and most picturesque chain of mountains in the world. In conclusion, a word is due to the engravers. The work was commenced by the late Dr. Keith Johnston, but the greater and the most difficult portions have been executed by Mr. John Addison. We have rarely seen better hill-engraving; and the wonder is, not that the appearance of the map has been delayed so long, but that a work of such magnitude and extraordinary minuteness should have been completed so soon. E. W.

#### REPORT OF PROF. PARKER'S HUNTERIAN LECTURES "ON THE STRUCTURE AND DEVELOPMENT OF THE VERTEBRATE SKULL"‡

##### VIII.—Skull of the Common Fowl (*Gallus domesticus*).

THE skull of birds is remarkable for the great amount of ankylosis which takes place between its various constituents long before the period of adult life. So complete is this union, that the determination of the separate bones in a full-grown bird is a perfectly hopeless task, without first studying their relation at a period when they retain their original distinctness. It will therefore be convenient to describe the fowl's skull, in the first instance, at the period of hatching, when the chief ossific centres are still separate, although most of the distinctive characters of the adult are already assumed.

In this stage the foramen magnum is surrounded by the four perfectly distinct elements of the occipital segment, between which extensive tracts of cartilage still exist. The basi-occipital is comparatively small, and forms almost exclusively the rounded condyle (Fig. 27 O.C.); the ex-occipital and supra-occipital are large and expanded, and into the latter extends the anterior semi-circular canal (Fig. 26, a.s.c.), so largely developed in birds. The prootic (Fig. 26, Pr.O.) is well seen on the inner side of the cranial cavity, but outside is completely hidden by the great development of the squamosal, which takes a very considerable share in the formation of the side wall of the skull. Two other auditory bones have

\* This has also been published separately on a scale of 1:25000.

† This has been published separately on a scale of 1:50000.

‡ Continued from vol. x. p. 446.

\* Karte der Schweiz, in 4 Blättern, reduciert unter der Direction des Herrn General C. H. Dufour. Maasstab, 1:25000. (Bern, 1873.)

appeared—the opisthotic (Op.O) and the minute epiotic (Ep.O); the latter attains a much greater size before it fuses, in adult life, with the supra-occipital. The main part of the skull floor is formed by the large, laterally expanded basi-sphenoid, which above is excavated into a deep *sella turcica* for the pituitary body, and in front passes into the interorbital septum and the bony rostrum

In front of this the cartilage is continued almost to the end of the beak as the *septum nasi* (Fig 26, s.n), or wall between the nasal sacs, the upper margin of which is produced outward into a wing-like expansion, the alinasal cartilage (Fig. 25, Aln) pierced by the external opening of the nostrils (A. N). A further continuation of the same median cartilages is seen in the slender pre-nasal or basi-trabecular (Fig. 27, B. Tr).

Within the nasal cavity are three pairs of cartilaginous folds, the alinasal turbinals represented by valvular processes of the ala nasi in some mammals, and the upper and lower turbinals, homologues of the structures bearing the same name in the higher class. The sole representative of the middle turbinal is the flat hinder wall of the ethmoid looking into the orbit, and known as the *pars plana* (Fig. 25, p. p).

There is one more point of importance to be noted with regard to the interorbital septum, namely, the cranio-facial notch' (Fig. 26, c.f.n), a natural separation between the epi- and cerato-trabecular elements, and of great functional importance in the bird, where the beak is moveable upon a sort of hinge formed by the premaxille just above this point.

The membrane bones of the face are yet to be considered. The premaxille are large bones partly fused

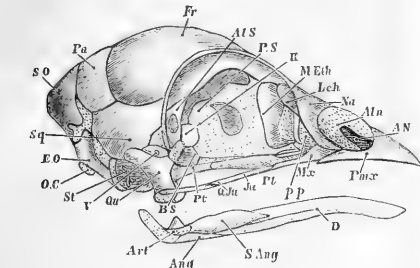

FIG. 25.—Skull of Fowl at the period of hatching (side view). p.p. pars plana

supporting it, being, in fact, firmly anchylosed with the latter. A careful study of the earlier stages of development shows that only the upper part of this bone is really homologous with the basi-sphenoid, the lower part being the representative of the hinder part of the parasphenoid. The basi-temporal (Figs. 26 and 27, B.T), as this large membrane bone is called, is firmly anchylosed with the basi-sphenoid, the greater part of the inferior surface of which it completely covers, but is at this period still partially distinct from the representative of the anterior part of the parasphenoid (Figs. 26 and 27, Pa.S), the "basi-sphenoidal rostrum" so characteristic of birds, which is, however, united with the basi-sphenoid.

In front of the depressed basi-sphenoidal region the basis cranii becomes much compressed from side to side, forming a large cartilaginous interorbital septum, the representative of the preputiary part of the basi-sphenoid and the presphenoid behind, and of the mesethmoid in front. The walls and roof of the brain-case are completed by the squamosals, alisphenoids, parietals, and frontals; the latter also affording support to the fore part of the base of the brain by means of their extensive in-turned orbital processes. The orbito-sphenoids are altogether absent at

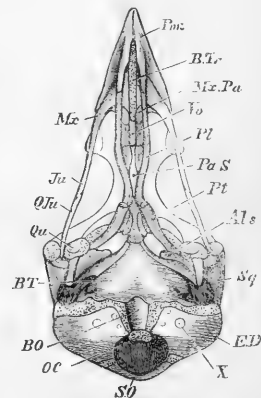

FIG. 27.—The same from beneath. Mx.Pa, maxillo-palatine process.

together in the third line, and provided with well-developed nasal, palatine, and maxillary processes. On either side of the former of these backward projections are situated the nasals, processes from which come downwards and forwards to bound the alinasal cartilage posteriorly. The lacrymal is a largeish bone lying in the upper part of the front wall of the orbit, articulating with the nasal, and directed outwards and backwards.

The bones of the upper jaw, or palato-maxillary apparatus, consist of two sub-parallel series, each of which articulates in front with the premaxilla, and behind with the quadrate; in the outer series are contained the maxilla, jugal, and quadrato-jugal, in the inner the palatine and pterygoid. All the bones in the former category are extremely slender—almost filiform, in fact; the palatines and pterygoids, on the contrary, attain a high degree of development, but neither they nor the maxilla develop palatine plates, the only rudiment of those structures being in the maxillo-palatine processes (Mx.Pa), flat plates of bone proceeding inwards from the maxille beneath the palatines to meet the small, single vomer. The palate of the fowl is thus formed on the simplest schizognathous type.

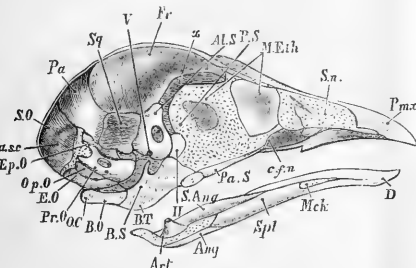

FIG. 26.—Sectional view of the same. B.T, basi-temporal.

this stage, but at a later period are represented by two pairs of insignificant ossifications above the postero-superior edge of the presphenoid in the membranous space marked x in Fig. 26.

A considerable portion of the anterior or ethmoidal part of the interorbital septum is already ossified, forming the *lamina perpendicularis*, or mesethmoid (M. Eth).

The quadrate is a stout bone, having three well-defined processes, one forming the articular surface for the mandible; a second, answering to the otic process of the primitive suspensorium, articulates with the squamosal; and the third, or orbital process, projecting forwards and upwards, is the pedicle or true apex of the mandibular arch. The otic process, besides articulating with the squamosal, bears a small facet for the prootic; this, in many birds, is developed into a distinct secondary head.

Immediately behind the quadrate is seen the large tympanic cavity; this is banded above by the supra-occipital and squamosal, below by the basi-temporal, behind by the ex-occipital, and in front by the basi-sphenoid; it sends into the latter a diverticulum, the anterior tympanic recess, and a second or posterior recess into the supra-occipital, through the diplœe of which it is continuous, as in the crocodile, with the tympanum of the opposite side. The fowl resembles the ostrich, and differs from most other birds in being wholly devoid of a tympanic bone.

The lower jaw consists of the same elements as already described in the snake, except that the coronary is absent in the fowl, though present in most birds; in this stage the five bones (articular, angular, supra-angular, dentary, and splenial) are perfectly distinct, and Meckel's cartilage yet remains of considerable size.

The upper part of the hyoid arch is separated, as in the snake and frog, to form with the stapes a *columnella auris*. From the oval, irregular, plug-like stapes proceeds a slender rod of bone terminated by a triradiate cartilage, of which the slender antero-inferior bar is the infra-stapedial, the broad somewhat expanded central segment the extra-stapedial, and the postero-superior bar the supra-stapedial. The latter is connected by an oblique bar with the extra-stapedial. The stylo-hyal is represented by the free end of the infra-stapedial.

The tongue-bone consists of a body made up of glossohyal (formed by the union of the lesser cornua), basi-hyal, and basi-branchial (uro-hyal) arranged in a linear series; and of two pairs of cornua, the anterior or cerato-hyals, very small, and forming more lateral projections to the body, and the posterior or epi- and cerato-branchials (thyro-hyals), long and elastic, and embracing the occipital.

The development of the fowl's skull has been worked out as far back as the fourth day; but even at that early period, when chondrification is only just beginning to set in, it is impossible to demonstrate with certainty the distinctness of many regions which are perfectly separate at corresponding stages in the lower types. At the period mentioned, the indifferent tissue of which the trabeculae are formed is perfectly continuous with that of the investing mass, and this again with that of the auditory capsules. When, however, the process of conversion into cartilage is complete, the apices of the trabeculae become perfectly distinct from the investing mass, and form a pair of backward-turned horns (often called the *lingulae sphenoidales*) on either side of the pituitary space. The ear capsules, on the contrary, remain as undistinguishable from the para-chordal region after chondrification as before, and only acquire distinctness by ossification. This rapid process of fusion which takes place equally between the masses of indifferent tissue constituting the primordial skull, in the subsequently formed tracts of cartilage, and in the various ossifications of a still later period, renders the study of the bird's skull one of the most difficult problems of craniology.

The manner in which the hyoid arch is developed has been worked out more exactly in the house-martin than in the chick, in which, however, the process is essentially similar. At a very early period the upper end of the arch grafts itself on to the auditory capsule, and at the same time becomes split up into three portions. The proximal of these constitutes the columella, a plug of the auditory capsule being before long cut out around its attached end

to form the stapes. The middle is the stylo-hyal; it is at first connected to the columella by a tract of tissue, but afterwards fuses with the infra-stapedial element of the latter. The distal portion never becomes chondrified in its upper portion, resembling in this respect the corresponding structure in man (the stylo-hyoid ligament), but below forms the lesser cornu of the hyoid bone, or cerato-hyal.

The mode of formation of the complex basi-sphenoidal region is, perhaps, the most important point which yet remains for consideration. No endogenous ossification takes place in the cartilage of this part of the basis cranii, but a pair of symmetrical ossific centres make their appearance in the thick web of perichondrium which underlies it, a third (median) centre appearing at the same time in front of the other two in the fibrous tissue below the ethmoidal cartilage. These ossifications together represent the dagger-shaped parasphenoid of the frog; the anterior is commonly known as the basi-sphenoidal rostrum; the posterior pair, coalescing, form the basi-temporal. Before they unite, however, ossification extends from them into the overlying cartilage, and thus the true basi-sphenoid is formed in a manner perfectly unique among vertebrata.

## THE NEW VINE-DISEASE IN THE SOUTH-EAST OF FRANCE \*

### II.

HAVING thus far studied the spread of the new vine-disease and the extent of the ravages committed by the Phylloxera, it is time to turn our attention to the insect itself, and to state the results of scientific observation of the manner in which it attacks the vine rootlets, and the various circumstances and conditions which either favour or retard the development of the disease.

The Phylloxera is a very minute insect, measuring, when fully grown, not more than 1-33rd of an inch in length. Its most striking feature is its proboscis, which lies in a sort of groove on the under-side of the insect, and with which it pierces the roots on which it feeds. This proboscis is very slender, and appears to be formed of three tongues, a greater one in the middle, and two more slender and shorter, on the two sides of it; it resembles a brown thread bending round and inserting itself in the tissue. The base of the proboscis is a sort of



The Phylloxera.

flat and sharp-pointed blade, composed of brown parts which prolong themselves into the tongues. The animal raises this blade a little in applying its proboscis to its food. The length of the sucker is equal to about half that of the body of the Phylloxera, which does not bury more than half of it in the bark of the roots. By this sucker the insect fixes itself to the spot which it has chosen, so that it can be made to turn upon it as on a pivot. In colour the Phylloxera, during the summer at least, is yellow, but in the late autumn it turns to a copper-brown tint, which lasts through the winter. The active life of the Phylloxera lasts from the beginning of April till the latter half of October. The insect hibernates through the other months, though previous to the commencement of hibernation the females who have laid eggs during the

\* Continued from vol. x. p. 566

past season, die off, leaving only young insects, which, as we have said, turn to a copper-brown colour at this period, renewing their light yellow tint in the spring. The Phylloxeras do not increase much in numbers during the months of April and May, but an extensive reproduction of the insect is clearly marked in June and July, while it assumes prodigious proportions in August and September, in the latter months often covering the root-shoots in a continuous mass, so as to make them appear completely yellow with their bodies. In observing the spots attacked by the Phylloxera, two varieties of the insect—a winged and a wingless—have been generally found; but it would seem (though on this point the reports before us are not quite clear) that the one is but a later development of the other. The wings of the Phylloxera do not appear to be capable of sustained flight, but probably help to carry the insect along from place to place when exposed to the action of the wind, for several specimens of the winged variety have been discovered caught in spiders' webs. Of course the winged Phylloxera spreads over the vineyards, which it attacks without any regard to the nature of the soil, whereas the wingless variety is much affected in its movements, and the extension of its ravages is largely determined by the quality of the ground and the nature of the obstacles to which it is exposed. Passing by, for the present, the observations made on this point, we may say generally that the insect would seem to have no burrowing power, but moves from place to place, from root to root, along the line of the fissures which the soil presents.

M. Maxime Cornu, as a result of his observations, has come to a conclusion contrary to the most commonly accepted theory of the cause of the disease of the vine, which attributes it to the absorption of the sap by the insect, and holds that the Phylloxera does not divert the sap to its own body, basing his conviction on his observations as to the length of the portion of the sucker buried in the rootlet compared with the thickness of the bark. He considers that what the Phylloxera really feeds on is the contents of the cellulose of the bark, and perhaps of the cambium layer. An exaggerated power of absorption has, in his view, been attributed to the Phylloxera, and it would rather seem that the flagging and ultimate decay of the vine arises, not from the absorption of the nutritive elements by the insect, but from the formation of new tissues, which divert them from their proper end to nourish abnormal growths. These new tissues or swellings (*englements*) of the roots are probably caused by an irritation of the cambium layer, the result of which is the hypertrophy of the excited part, while the formation of the swellings brings about the death of the rootlets, and through them the general decay of the vine. A natural conclusion from these observations is that the health of the vine may be improved by any means tending either to produce fresh rootlets or to increase the absorption of nutritive elements by those already in existence, though the only true and radical remedy is to kill or drive away the Phylloxera itself.

When a vine is first attacked by the Phylloxera, a change occurs in the external appearance of the rootlets, which, instead of being nearly cylindrical, exhibit the swellings we have just mentioned of different shapes, which are the first symptoms of the disease. The Phylloxeras may often be seen on their surface. These swellings are hard, and of a greenish or yellowish, or sometimes of a deeper-coloured tint, according to that of the external coat of the root when they are full of sap, but when they rot they become black and flabby, and eventually dry up altogether.

It is interesting to examine and compare in the same root the structure of the part above the swellings with that of the swelling itself, as by these means one can come to a definite opinion, by comparing the diseased with the healthy part, as to what are the new elements

which are developed, and what are the characteristics of the altered parts. By making a transverse section above a swelling in the vine, the structure is found to be that of a normal root-shoot; and, with the aid of a microscope magnifying 60 diameters, the following appearances may be observed:—(1) On the outside the external coat (*couche subéreuse*) composed of flattened cells, arranged in rows and brown on the outer side: this tissue peels off in layers of a brown colour, and it is this that gives the rootlets the yellow or brown tint they show according to its thickness. (2) The cortical parenchyma, composed of polygonal cells, full of starch, some of which, larger than the rest, scattered about here and there, contain bundles of raphides, long crystals parallel to each other. These two constitute the cortical coat. (3) The woody portion, composed of fibres and vessels, occupies the centre, and is divided into three, four, or five woody sectors, and between each two of these is a medullary ray—there is no definite pith. (4) Embracing the woody tissue and in contact with the cortical coat is the cambium layer, the flattened cells of which, with their thin walls, full of a thick plasma and always destitute of starch, form on the one side the cortical and on the other the woody tissue. The general contour of the section is circular. To turn to the swellings.—The increase in diameter is due to the formation of new elements, partly cortical, partly woody, the cortical parenchyma becoming much thicker, but otherwise resembling the healthy tissue. It is different with the woody tissue: the woody rays assume very irregular outlines, and swell in all directions unevenly beyond the limit of the single concentric circle which terminates them with its circumference, in the healthy state. The development of the cambium layer is also abnormally increased, and there seem to be no vessels in the new wood formed under these conditions.

This altogether anomalous anatomical constitution is in itself a refutation of those who even now hold that the swellings are the result of normal growth. They really are a purely local hypertrophy produced by the direct action of the parasite.

It is of great importance to the discussion of possible means of extirpating the new insect, to investigate the method it employs in getting from place to place and so spreading its ravages. Putting aside as obvious the movements of the winged variety, which, as we have said, seems to be borne to fresh spheres of mischief by the wind without any direct effort of flight on its own part, we come to the wingless insect. Observation shows that the wingless Phylloxera progresses both along the surface of the earth and follows also the line of the roots or the fissures of a crumbly or broken soil. And first, to deal with the surface-movements of the insect, they appear to be extraordinary occurrences, the results of the concurrence of altogether special circumstances, for the exposure to the air and to the sun's rays is very unfavourable to the Phylloxera, which in the dry air dies of desiccation, as may be easily shown by leaving exposed a root covered with Phylloxera. It would seem, therefore, and observation supports this idea, that the reason of the surface-movements of the insect lies in the fact that in getting from vine to vine, or sometimes from rootlet to rootlet, it encounters obstacles which, not being a burrowing insect, it cannot overcome, and therefore from unwelcome necessity it has to mount to the surface, though only to bury itself again when the next fissure shows itself, leading to a fresh and unattacked part. With respect to the movements of the parasite underground, some elaborate observations have been made by M. Duclaux, and it is worth while to examine his results. If one were to ask himself, *a priori*, which kind of soil among those that prevail in the south-east of France offers the greatest difficulty to the movements of the Phylloxera, the answer which would inevitably suggest itself would be that the sandy varieties are the least per-

meable by it. A clayey soil offers, as observation proves no less than reason, great facilities to the passage of the insect, which is not hindered by its slippery nature when wet, for it can walk without difficulty up the vertical sides of a glass bottle. Such a soil cracks everywhere in drying, and forms fissures in all directions, vertical and horizontal, thus laying bare the roots of the vines in many places; moreover, the digging and dressing of the vine leaves the soil in lumps about the roots, separated by numerous chinks which afford every facility to the passage of the insect. A calcareous soil generally resembles a clayey one with respect to the means it affords for the movements of the Phylloxera; it is only when the limestone it contains is disseminated through it in the shape of sand or small gravel that a calcareous soil at all resembles in its properties a sandy formation. This latter kind it is, which, being always dry, always well settled, constantly enveloping the roots on all sides, puts great obstacles in the way of the circulation of the insect, which can find no chinks large enough for its purposes underground, while on the surface it gets entangled in its movements like a fly in a dish of honey. A soil formed of large pebbles cemented together with clay will not, however, be favourable to the Phylloxera, for it does not crack like the purely argillaceous formation; and though the vine, which can push its way everywhere, does so there also, the insect cannot. A very little clay more or less serves to give very different properties to the earth from the point of view of the Phylloxera, and hence it is that one can explain a phenomenon often noticed, namely, a small portion of a vineyard remaining in a flourishing condition in the midst of general decay. A close examination of the soil in these cases removes all cause for wonder, for a lump of damp earth taken from the diseased quarter and pressed between the fingers may be worked and moulded like dough, while a piece taken from the healthy part crumbles and is less tenacious. Were it otherwise at all doubtful, figures would show that the vines in the south-east of France are healthier or the reverse, according as the soil is less or more clayey. Thus a physical analysis of some earth taken from a vineyard of M. Faucon, at Graveson, where all but one little plot was subjected to the attacks of the Phylloxera, gives the following results:—

	Healthy part.	Diseased part.
Water ... ..	2'25	3'20
Nitrogen ... ..	0'11	0'12
Sulphate of calcium ... ..	0'62	0'42
Chloride of sodium ... ..	1'15	0'18
Carbonate of calcium ... ..	49'00	42'00
Siliceous sand ... ..	23'50	10'20
Clay ... ..	17'75	37'50
Organic substances and errors of analysis ... ..	5'62	6'38
	100'00	100'00

Among the different varieties of soil which are more or less favourable to it, the Phylloxera as one would suppose without observation shows traces of its presence in a poor dry and shallow soil first of all, then in clayey damp ground, and after that in calcareous tracts, according to the degree of difficulty which vines, planted in these soils, present to its operations; eventually, in the same way, the disease shows itself in other kinds of earth, with a rapidity or the reverse which is in proportion to the amount of strengthening juices which the vine can imbibe from them, and the obstacles which the insect meets with, till at last no vines are left intact but those which are planted on a soil impenetrable to the parasite. This phenomenon, if such it may be called, of the disease, will serve to explain, what we have already discussed in a former article (vol. x. p. 503), the spread of the disease in its earlier years, and the great and alarming increase of the extent of territory affected in 1867-1868. Regarding the observations just made, we can see that

probably the Phylloxera was spread over the whole area of the two departments of Vaucluse and Bouches-du-Rhône, which in the two last-mentioned years were so formidably damaged in their vineyards, as early as 1865, when the disease only appeared on the plateau of Pujaut. The alternative hypothesis, that the disease radiated from a central point at Pujaut, presents great difficulties, as it does not allow sufficient time for the emigration of the insect to the points where it appeared in 1867-1868, while it makes it leave a district not in any way exhausted, disregarding the known habits of the Phylloxera. It would seem, therefore, that we may put aside any idea of a progressive irradiation of the disease around a single centre, and explain existing facts by attributing them to a general dissemination of Phylloxera, before 1866, over the territory lying along the valley of the Rhône, between the Drôme and the sea, though the insect only showed traces of its presence according to the nature of the soil in different parts, in some sooner, in others later. We may, indeed, regard it as almost certain that the disease began with the invasion before 1865 of a vast surface, in which different points have shown the traces of the insect's presence successively, and that from a cause analogous to that which shows us, when an island emerges from the sea, its highest peaks appearing first, the others afterwards, in the order of their altitude. By the use of this illustration, supplied by M. Duclaux, we can set before ourselves a graphic picture of the history of 1865, 1866, 1867, and 1868 in the vineyards of South-eastern France.

We will not dwell at any length on the different attempts at treatment of the disease, as they have more practical interest for those who live in vine-growing countries. Many of these attempts have been failures, owing to their having been based on false hypotheses as to the origin of the disease of the vine. When, in July 1868, M. Planchon discovered the Phylloxera, attention was naturally turned to the employment of insecticides, but the difficulty lies, not in the discovery of a substance fatal to the insects and harmless to the vine, but in its application underground to all the parts attacked. It was soon found that those insecticides, at least, which are insoluble in water, cannot be applied generally to the seat of the disease, and this fact led to the trial of immersion, in the hope that, instead of being like many remedies suggested, only partial, serving merely to delay the death of the vine, it would prove a radical means of cure. M. Faucon was the first practical vine-grower to employ immersion, as distinguished from the mere watering of the vine; but this method, though entirely successful in his case in the parts where it was applied, is obviously not capable of universal adoption. The physical conformation of the soil, the absence of a water-supply from any river, and the fact that the finest vines grow on slopes, which are not of course amenable to this treatment, to which we may add its great expense, except in very conveniently situated districts, make it only practicable over limited areas. The remedy, therefore, which is to eradicate the Phylloxera and restore to France her full supply of wine, the national drink and the great source of national material prosperity, is still undiscovered. Science throughout France is striving its utmost to discover the potent method of destruction of the Phylloxera, little doubting that some such there is. The thought of thinking minds engaged on this subject should be like that to which M. Faucon so eloquently gives utterance:—"When we feel that we are threatened, and see that we are already attacked, have we no other resource than feverish attempts, barren lamentations, or a resigned submission? Yet help never comes but to those who deserve it, and who, in wrestling with the plague by which they are attacked, are obeying, whatever bigoted minds may think of it, the strict call of duty—nay, we may say a command of heaven itself."

## EARLY OPENING OF KEW GARDENS

OUR readers are no doubt aware that a movement has been set on foot for the earlier opening of Kew Gardens, a step which, if taken, would, we believe, wholly alter the character of that institution. It would, we feel assured, seriously interfere with all scientific work, and with the uses which we hope will one day be made of the gardens in the mornings by science schools. Moreover, we doubt if there exists any general desire for their early opening, and are inclined to believe that the movement is quite local in its origin and extent. On this subject we are glad to quote the remarks in a recent number of the *Economist*, both on account of their pertinency and force, and because we rejoice to see the true interests of science advocated by papers not professedly scientific:—

“The question has been mooted of late whether the Royal Botanic Gardens at Kew could not be opened to the public at an earlier hour than the present time of 1 p.m. A little reflection will enable those who ask this question to perceive that it can scarcely be answered in the affirmative without inflicting a serious injury on the real utility of the gardens and on the public service. In the first place, all the real work of the gardens has to be done during the hours when they are closed to the public. As it is, this time is barely long enough for the duties which have to be performed in it. To open the gardens in the morning would require a second staff of gardeners and workmen, as strong, or nearly so, as the existing one. Even with this extra assistance and this greatly increased cost, the work could not be as well executed as it is at present. In the next place, as the name of the gardens implies, they are *botanic* gardens. Besides those who ordinarily frequent the gardens for pleasure, there are many artists and scientific men who visit them for purposes of study; the only time when they can do this with advantage is before the general public are admitted.

“Of late the public has come in rushes of 12,000 to 60,000 in a day. If only 10,000 persons were in the gardens in the forenoon, all work would necessarily be at an end, and it would be impossible to maintain the existing character of the place. As it is, the Botanic Gardens at Kew are more accessible to visitors than any other public institution. Week days and Sundays alike the gates stand open. At the British Museum and the National Gallery—between the hours of opening which and the gardens at Kew comparisons have been drawn—there are many hours and even days when those institutions are necessarily closed to the public for purposes of cleaning, putting in order, and making good the results of the wear and tear of the enormous traffic. But if the heads of those institutions had, like the Director of the Royal Gardens at Kew, to *grow* what they exhibit, they would doubtless require many more close days than they do at present.

“Nor is it merely the work of maintaining the gardens and grounds in their present efficiency which has to be carried on in those hours during which the gates are closed to the public. It should not be forgotten that the Royal Gardens at Kew have performed services to the British Empire which no other public institution could undertake. The successful introduction of the Cinchona tree into India (a resource to that country the importance of which cannot be over-estimated), the efforts being made at the present time to procure fresh and improved coffee for Ceylon—to single out only two from a host of similar instances in which the Director of Kew Gardens has freely placed his botanical science and invaluable practical knowledge at the service of the public—will show how diversified and extensive the operations of the gardens are. To prevent these being carried out as they are at present, would be a serious injury to the public

service. The present Director, Dr. Hooker, and his father, Sir W. T. Hooker, who held the same office before him, have done everything in their power, consistently with the proper maintenance of the gardens in due working order, to facilitate the use of them by the public generally; and in the interest of science as well as for the prosperity of the gardens, it is to be hoped that the public will see the desirableness of being satisfied with the present very ample allowance of opportunity for visiting the Botanic Gardens at Kew, and that they will not insist on acting over again the fable of the goose and the golden eggs for the sake of a little present pleasure.”

## THE GEOGRAPHICAL DISTRIBUTION OF AURORÆ

IN an interesting paper in Petermann's *Mittheilungen* for October, Prof. Fritz gives the results of his extensive researches on this subject. The investigation is beset with difficulties, not only from the deficiency of observations, but from their irregularity. While some observers content themselves with noting only the more remarkable displays, others register the faintest light to the north as an aurora. One observer continues his observations for tens of years, while another, whose zeal has been roused during a period of maximum frequency, allows it to cool when a minimum, with its rare and feeble displays, again returns. The research is further complicated by the fact that the appearance is not only dependent on latitude, but undergoes a periodic change, which in the region of most frequent display manifests itself less in diminished number than in diminished intensity of aurora; and because in some places the phenomenon is far more frequently concealed by a cloudy sky than in others.

As far as possible to eliminate these sources of error, Prof. Fritz compares the mean number of observations for any given place with the mean for mid-Europe between 46° and 55° lat. (or between the English and Scotch boundary and the Alps) for the same period, by the following formula:—

$$M = \frac{C}{172} \cdot \frac{B}{E} = 28 \frac{B}{E}$$

where M is the mean calculated frequency for the given place, C the total number of aurora in the author's catalogue for mid-Europe from 1700 to 1871=4830, B the number of auroræ for the period of observation for the given place, and E the number from the author's catalogue for mid-Europe for the same period. Thus, for example, he calculates for Christiania:—

$$\begin{aligned} 1837-1854 & B = 529 & E = 581 & M = 25.5 \\ 1855-1870 & B = 436 & E = 568 & M = 21.9 \\ 1837-1870 & B = 965 & E = 1,149 & M = 23.3 \end{aligned}$$

As we have already remarked, a complete agreement of the different mean values is not to be expected, both on account of errors of observation, and from the various local influences of climate and situation. Professor Fritz gives tables of the numbers of observed auroræ, and calculated values of M for upwards of 200 places in Europe, Asia, and America; and from these, proceeds to lay down on a chart of the northern hemisphere a series of curves of equal frequency of auroral display, which he calls *isochasmen*. He discusses with great care the probable value of the observations, and lays down the curves so as to include on either side of them as many observations above as below the required value. But a few instances will make his method clearer than any description.

The zone M = 0.1 passes through the southernmost part of Spain, through Calabria, and just north of the south coast of the Black Sea, through the Sea of Aral and Lake Balkchash, south of Saghalien and the Kurile



Islands, north of the Sandwich Islands, through the southern point of California, through Mexico and Cuba, and just north of Madeira. In fact, through its whole course it lies just south of the isoclinic line of  $60^\circ$  inclination and between this and that of  $50^\circ$ ; a fact forcibly illustrating Prof. Fritz's remark that the isochasmic curves lie nearly parallel to those of equal magnetic inclination. For this curve we have for the value of  $M$  in Madeira, Cadiz, Naples, Smyrna, Teneriffe, and Cuba  $0\cdot1$ , for the Azores  $0\cdot15$ , for Barnaul  $0\cdot7$ , and Nertschinsk  $0\cdot6$ .

It is well known that both in ancient and modern times polar lights have been seen occasionally south of this line, as for instance in the year 502 at Edessa, in 1097, 1098, and 1117 in Syria, in 1621 at Aleppo, and in 1872 over most of North Africa and India.

North of this line their frequency rapidly increases, and we have  $M = 1$  beginning at Bordeaux, through Switzerland and north of Cracow, south of Moscow and Tobolsk, and north of Lake Baikal, through Udsch and the southern point of Kamtschatka, through northern California and the north of Florida. For the values of  $M$  for this zone we have for Perpignan, Marseilles, Bordeaux, La Rochelle, and Viviers, a mean of  $1\cdot1$ , for Moscow  $1$ , for Tobolsk  $0\cdot9$ , Barnaul  $0\cdot7$ , and Sacramento  $0\cdot8$ . Singularly enough, probably from climatic or other local causes, the value of  $M$  for New Orleans is only  $0\cdot14$ .

The zone for  $M = 30$  passes through the north coast of Ireland, through Scotland near Edinburgh, through the White Sea and the Gulf of Obi, where it attains a latitude of  $70^\circ$ , and then tends a little southward through Werchni, Kolymsk, and the Bay of Anadyr, near Sitcha, Cumberland House, Quebec, and the north coast of Nova Scotia, to the north coast of Ireland.

North of this the frequency of aurora rapidly increases. The zone of  $M = 100$  passes through the Hebrides, Shetland, near Drontheim and Wardon, through Nova Zembla, across Behring's Straits, just south of the Arctic Circle, south of Lake Athabasca, through Hudson's Bay, and just north of Newfoundland.

Only a little further north we reach a zone of maximum frequency, beyond which the intensity of auroral display again declines, contrary to the old idea that its intensity increased up to the poles. This zone passes just north of Faroe and of the North Cape, through the northern part of Spitzbergen, and just north of the Siberian coast, near Point Barrow, Great Bear Lake, and Nain on the coast of Labrador. Iceland, Spitzbergen, and Greenland lie considerably to the north of this zone, and auroræ are not there so frequent, nor especially so brilliant as at Faroe, the north coast of Norway, and Labrador. Of this Prof. Fritz adduces much evidence, and in addition draws attention to the important fact, that while south of this zone of maximum frequency the arches are generally north of the observer, from the north of it they appear to the south, and upon it, indifferently, north, south, or overhead.

It will be noticed that the system of curves tends strongly southward in North America, while in the Atlantic and Pacific Oceans the curves pass rapidly northward and reach their highest latitudes in Central Asia. This is borne out by the fact that the great auroræ of Aug. 28 and Sept. 1, 1859, were not noted in the meteorological registers either of Nertschinsk, Barnaul, or Jekaterinburg, nor were they seen at Tigris in Yozgat ( $39^\circ$  N.), Mosul ( $36^\circ$  N.), or Kharput ( $33^\circ$  N.); whilst in the Atlantic Ocean they were visible at least to  $12^\circ$  N., in Africa to St. George del Mina ( $28^\circ$  N.), and in America during the maximum they were frequently observed in the Antilles ( $20^\circ$  N.).

The geographical extent of great displays of polar lights is very significant. That of Sept. 1, 1859, was visible in the Sandwich Islands ( $20^\circ$  N.), Sacramento ( $20^\circ$  N.), San Salvador ( $13^\circ$  N.), in the whole Atlantic Ocean to  $12^\circ$  N., in Western Africa to  $14^\circ$  N., and in the whole of Europe. At the same time the southern lights

were seen in Australia, South America to  $33^\circ$  S., and in the Indian Ocean to  $39^\circ$  S.

For the southern hemisphere there are as yet too few observations to calculate the distribution as has been done for the north. For Hobarton ( $43^\circ$  S.)  $M = 6$ , and for Melbourne  $15$ . In low latitudes they have been seen at Cosco ( $12^\circ$  S.) in 1744, at Rio Janeiro ( $23^\circ$  S.), 1783, at Bloemfontein ( $29^\circ$  S.), and Vaal-Fluss ( $28^\circ$  S.); in Africa and at Réunion and Mauritius in 1870 and 1872.

Dr. Fritz remarks that his zone of greatest frequency nearly coincides with that given by Muncke (in "Gehler's Wörterbuch"), and that the whole curve-system has great similarity to the zone-system of Loomis in *Silliman's Journal*, vol. xxx. The curves cut the magnetic meridians in most places at right angles, and are very similar to the isoclinic curves constructed by Hansteen in 1780, while they noticeably deviate in places from those of Sabine of 1840, and approximate, at least in the best determined portions in East America, the Atlantic Ocean, and Europe, with the isobaric curves of Schouw. It may here be remarked that the curves of increasing frequency in the Atlantic Ocean tend towards the point of lowest barometric pressure.

It is also noticeable that throughout the greater part of the northern hemisphere the curves tend to follow the form of the continents, and the limits of perpetual ice which depend upon it; and Prof. Fritz points out that in mean latitudes the magnetic meridians and the direction of visibility of the aurora are coincident, and are mostly (*viz.*, from the Atlantic Ocean to the Asiatic Icy Sea) normal to the limit of ice. The greatest deviations from this rule exist in places where the ice-limit is most irregular, as, for instance, in Hudson's Bay and the Gulf of Labrador. It may here be noted that at Fort Franklin, Fort Normann, and Wardochus the northern lights begin in spring to be seen most frequently in the south at the same time as the ice-limit deviates furthest in the same direction. At Bossekop, according to the report of the Scientific Commission, the northern appearances are to the southern ones as  $3\cdot6$  to  $1$  during the four last months of the year, but only as  $2$  to  $1$  in spring. Wrangel, from his observations on the coast of the Arctic Ocean, concludes that the freezing of the sea is favourable to aurora; but remarks that in the east of Asia the appearance is more frequent as the coast is approached, and is most so during the increasing cold of November, while it becomes rarer in January, when the coast ice extends further to the northward. M'Clintock notices that aurora was most frequently visible when water was in sight; and Hayes, that it was more frequently seen in the direction of some piece of open water than of the magnetic north. These observations would rather support a belief common in Scotland that the frequency of the aurora varies with increase and decrease of the Greenland ice, and render it probable, at least, that ice-formation is one of the most prominent local influences by which auroral distribution is affected. It seems not unlikely that the neighbourhood of the Alps may influence the frequent displays in North Italy. These and other points, however, require more systematic observation, and it is especially desirable that some notice should be taken of the relative intensity of different displays.

H. R. P.

EDWIN LANKESTER, M.D., F.R.S.

IT is with great regret that we have to announce the death, from diabetes, on Friday last (October 30), at Margate, of Dr. Lankester, the Coroner for Central Middlesex.

Dr. Lankester was born April 23, 1814, at Melton, near Woodbridge, in Suffolk, at which latter town he received his early education and commenced his medical studies. In 1834 he entered University College, London, as a

medical student, and took the membership of the College of Surgeons, as well as the licentiatehip of the Apothecaries' Society, in 1837. In the year 1839 he graduated at Heidelberg, and was appointed lecturer on *Materia Medica* at St. George's School of Medicine four years later. In 1845 he was elected to the Fellowship of the Royal Society, and five years afterwards became Professor of Natural History in New College, London. In 1851 he received the degree of LL.D. from Amherst, U.S.; in 1853 was made lecturer on Anatomy and Physiology at the Grosvenor-place School of Medicine; in 1858, Superintendent of the Food Collection, and in 1862 Examiner in Botany to the Science and Art Department of the South Kensington Museum. In 1859 he was President of the Microscopical Society, and in 1862 he was, after a severe contest, elected Coroner for Central Middlesex, which post he retained until his death.

For about twenty-five years Dr. Lankester was secretary of Section D of the British Association, of which he was one of the originators, being a most intimate friend of Edward Forbes, with whom, in his younger days, as a bachelor, he lodged in London. In conjunction with Mr. Busk, he for eighteen years edited the *Quarterly Journal of Microscopic Science*, after which he did so with his son, Mr. E. Ray Lankester, Fellow of Exeter College, Oxford.

Dr. Lankester's contributions to scientific and medical literature are very considerable. He edited the Natural History portion of the "English Encyclopædia," and contributed the article "Rotifera" to Todd's "Encyclopædia of Anatomy and Physiology." In 1849 he published a translation of Schleiden's "Principles of Scientific Botany," and, in 1859, of Kirchenmeister's "Animal Parasites." In conjunction with Dr. Lecheby he contributed the article on Sanitary Science to the "Encyclopædia Britannica." Among his most popular works is the well-known "Half-hours with the Microscope." His contributions to this journal have been several, and, like all that he wrote, are marked by their admirable style and tone, as well as by the liberal spirit of modern scientific thought, which gives them an almost youthful freshness; we have, not less than others, to deplore the loss that has been sustained by ourselves in his premature decease.

To those who, like the present writer, were acquainted with him, and had the privilege of passing many pleasant hours in his company, Dr. Lankester was always genial and kindly, inspiring others with that hopefulness which was so marked a feature of his own character. He made many sincere friends, amongst whom was Henfrey the botanist, who named the genus of plants (which is grown in many nursery gardens) *Lankesteria*, after him. It was his kindly spirit which directed his attention to questions of social organisation, and he always referred to the articles by himself, in the *Daily News*—when a young man—on Medical Reform, as having been of assistance in the passing of Mr. Wakley's bill. His remains were interred in the churchyard of Hampstead Church on Tuesday last.

### NOTES

NEWS concerning three of the Transit Expeditions is to hand. Advice from Capetown of Oct. 6 state that the German screw corvette *Gazelle*, bound to Kerguelen on the Transit Expedition, arrived in Table Bay and left on Oct. 4. The *Gazelle* will visit the Crozette Islands, and proceed from thence to Kerguelen. If circumstances are favourable she will search for a warm current, supposed to exist between 60 and 50 east, and endeavour to reach Wilkes Land. She will then visit the north and west coast of Australia, the coast of Guinea, and several island groups of the Pacific. Lord Lindsay had arrived out and left for Mauritius in his yacht, there to watch the transit of Venus. A Cairo correspondent of the *Daily News*, writing under

date Oct. 20, sends a long account of the preparations made by the Egyptian party. General Stanton, the Consul-General, has taken the greatest interest in the expedition, and put himself to considerable trouble to make everything smooth for the party and enable them to make all the necessary arrangements. All the instruments have arrived safely, and Capt. Browne, the chief of the party, has determined to erect his observatories on the top of the Moquattam Hills, a distance of about three miles in a direct line from Shephard's hotel. They are about 600 feet in height and overlook the whole country. Capt. Browne, who has been carefully observing the atmosphere, finds it free of moisture, at least about sunrise; which is most important, as the maximum altitude that will be observed will be only 15°. It is at present the intention to form a camp on the top of the hill, the tents having been furnished by the Egyptian Government. Mr. Dixon, a civil engineer in Cairo, has been of great assistance in the matter of transit. Capt. Abney was expected to leave for Thebes on the 26th. Admiral Ommaney had arrived at Alexandria, but to what party he would be attached was not known.

THE generally well-informed London correspondent of the *Scotsman* states that another Arctic Expedition will be despatched in the ensuing year under the auspices of the Government and the Royal Geographical Society. He believes that it is so far considered an accepted fact that the expedition will leave these shores in the spring of 1875, inasmuch as it has the approval of the Premier.

SOME time since we pointed out the extreme inconvenience of the form and manner in which our learned societies publish their "Transactions." Anyone who is not a Fellow, for example, of the Royal Society, and who may wish to possess a memoir, say on some physiological subject published in the "Philosophical Transactions," is probably debarred from doing so by finding that he must purchase with the memoir which he wants a number of others belonging to the most diverse subjects, pure mathematics being almost invariably one. We advocated, as the common-sense remedy for this state of things, the sale of separate copies of each memoir. We were not aware at the time that this was actually done by the Linnean Society. After the completion of the twenty-sixth volume of its "Transactions," it was decided by the Council that twenty-five separate copies of each memoir should be kept for sale. Probably because the arrangement is not generally known, the sale of the part of the "Transactions" is still as good, if not actually better than that of the memoirs which they contain. The price is, however, proportionally higher, which may have something to do with this. Thus the part of the "Transactions" containing Prof. Owen's memoir on the King Crab is sold to Fellows for 9s., to the public for 12s. The corresponding prices of the memoir itself (of which no separate copies have been sold) are 7s. 6d. and 10s. But the part also contains another paper, the prices of which are 4s. 6d. and 6s. In one case all the available spare copies were purchased by the author.

WE are glad to be able to announce that a considerable portion of the galleries of the late International Exhibition at South Kensington, taken by the India Office, will be devoted to the display of Natural History collections of that department of the Government. The fact of the collections having been kept in an unavailable form for so many years past has always been a great grievance to working naturalists, and has called forth many remonstrances, from ourselves among others.

MR. RICHARD LYDEKKER, B.A., of Trinity College, Cambridge, second in the First Class of Natural Sciences Tripos in 1871, has been appointed to the Palæontological Department of the Geological Survey of India in the room of the late Dr. Stoliczka. Mr. Lydekker left some months since for India,

in company with some friends, their expedition having the combined objects in view of sporting and the pursuit of natural history, and has passed most of the interval in Cashmere and Thibet, where he is believed to have made very considerable collections—zoological, botanical, and geological.

MR. MARTIN, Senior in the Natural Science Tripos of 1873, was last week elected to a Fellowship at Christ's College, Cambridge.

GODFREY'S Laboratory, Maiden Lane, Strand, in which the Hon. Robert Boyle worked out his phosphorus experiments, has been converted into a Roman Catholic chapel.

SOME of the Paris newspapers announced that M. Wurtz, Dean of the Faculty of Medicine at Paris, would be obliged to resign; the *Figaro* went so far as to give the name of the intended successor of the celebrated Professor of Chemistry—a M. Depaul. The rumour happily has proved false, and was maliciously spread because a clerk employed in the office of the Faculty had been dismissed for misdemeanour. There is, however, to be a demonstration among the students in honour of M. Wurtz, who is a great favourite with them.

THE Professorship of Applied Mathematics and Mechanism in the Royal College of Science for Ireland (Science and Art Department), vacant by the appointment of R. Ball, LL.D., F.R.S., to the Professorship of Astronomy in the Dublin University, has been filled by the appointment of H. Hennessey, F.R.S.

DR. JAMES APJOHN, F.R.S., has resigned the Professorship of Chemistry in the School of Physic attached to Trinity College, Dublin. Dr. Apjohn still holds the Professorships of Applied Chemistry and of Mineralogy in the University of Dublin. The Provost and Senior Fellows of Trinity College, Dublin, will, pursuant to the School of Physic (Ireland) Act, proceed on the 30th of January, 1875, to elect a Professor of Chemistry. There is a fixed salary of 400*l.* a year, with an additional payment of 100*l.* a year on condition that a number of Senior Sophisters nominated by the Bursar shall have free laboratory instruction. In addition the Professor has the fees for lectures and laboratory instruction, which ought to equal, at the lowest calculation, 400*l.* a year. The Professor will have the use of the college laboratory for analyses bearing on medical chemistry, such as medical and medico-legal investigations, and analyses connected with purposes of public health. Candidates are required to send their names, with the places of their education, the Universities where they have taken their medical degrees, and the places where they have practised, to the Registrar of Trinity College, Dublin, and to the Registrars of the King and Queen's College of Physicians in Ireland, Kildare Street, Dublin, on or before the 23rd of January, 1875.

IN accordance with the wishes of the Professors of the Medical School of Trinity College, Dublin, the Provost and Senior Fellows have resolved that a three months' course of practical instruction in Human Histology shall be added to the curriculum for the degree of M.B., the same to be under the superintendence of Dr. Purser, King's Professor of the Institutes of Medicine. 110*l.* has been voted to buy twenty microscopes, and we presume a room will soon be built for the purpose.

THE competitive system is making 'daily progress' in France. Four *Commissaires de Police* being required, the Prefect of the Seine instituted a competition among the police-secretaries, and fourteen candidates offered themselves. A committee of examiners was appointed, the examinations have been held, and the candidates are awaiting the result, which will be issued very shortly. Up to the present time *Commissaires de Police* have been appointed at the discretion of the Prefect, only from

amongst gentlemen holding the diploma of Licentiate in Law, and secretaries of police are obliged to possess that qualification before being admitted to the examination.

EACH year the five Paris Academies—the Academy of Sciences, the Academy of Fine Arts, the Academy of Inscriptions, the Academy of Moral Sciences, and the French Academy—hold a general meeting on the 25th of October, the anniversary of 3 Brumaire, an. IV. (25th October, 1795), the day when the French Republic published the law organising the National Institute. During the Restoration the meeting was held yearly on the 24th April, the day when King Louis XVIII. returned to France, with the foreign troops, after the battle of Waterloo. When the Republic was proclaimed in 1848, a decree changed the date of the annual celebration to the 25th October; but when Napoleon III. accomplished his *coup d'état*, he appointed the 19th of August, which was continued to be the date to 1870. The Republic being again proclaimed, the celebration was restored to the 25th of October. Each Academy or Class of the Institute appoints successively the president of the meeting. The turn of the Academy of Sciences having come round this year, M. Bertrand, who is the president in charge, was the chairman of the whole Institute. His being a candidate for the perpetual secretaryship has given much interest to his presidential address, which was printed at full length in all the papers, and largely approved.

THE Prefect of the Seine has appointed a Commission to inquire into the state of lightning conductors—which are in a very imperfect condition on some public buildings—and the best method of testing their efficacy. The institution of this Commission appears to have been suggested by the corresponding committee which was appointed by the British Association, and which existed during two years without any result. It is to be hoped that the Parisian Commissioners will be more successful.

THE Municipal Council of Paris will very likely ask from the Government an authorisation to establish industrial schools in that city.

AT a meeting held a year ago in Islington, a large number of influential gentlemen were appointed a committee to obtain for that large and important district a Public Library and Museum, under the "Public Libraries and Museums Act." A requisition to the vestry and overseers of the parish was circulated for signature, and the scheme has, we believe, met with general approval, so that we hope soon to see it carried into effect.

M. FAYE has officially announced himself a candidate for the post of Perpetual Secretary of the Academy of Sciences, but the chances of M. Bertrand do not appear to have been greatly altered.

THERE will be an examination at Sidney College, Cambridge, on Tuesday, April 6, 1875, and three following days, of students intending to commence residence in the following October, when (provided fit candidates present themselves) two scholarships will be awarded for natural science, one of the value of 60*l.*, and one of the value of 40*l.* The scholarships will be tenable, under certain conditions, until the time of taking the B.A. degree, or until promotion of others to greater value.

A COPY of the *cœlometer*, an instrument invented by Mr. W. Marsham Adams, B.A., late Fellow of New College, Oxford, for the purpose of illustrating elementary astronomy, is to be placed in the Examining Department of the Board of Trade at Tower Hill, and also on board her Majesty's training-ship *Conway*, at Birkenhead. Rear-Admiral Sir A. Cooper Key has we believe, signified his intention of applying to the Admiralty for leave to purchase one for the Naval College at Greenwich, of which he is the president.

WE have just received a paper by Dr. Pietro Pavesi, Professor of Zoology and Comparative Anatomy in the University of Genoa, entitled: "Contribuzione alla storia naturale del genere *Selaché*," in which that naturalist shows that the Rasheigh Shark (*Polysprosopus rasheighanus*) and the Broad-headed Gazer (*P. macer*), described as British by Mr. Crouch in his work on the fishes of our seas, are not, as Dr. Günther suggests in his valuable Catalogue of Fishes in the British Museum, monstrosities of *Selache maxima*, but belong to a species found in the Mediterranean, *Selache vostrata* (Macri), in which the eyes are situated at the base of the elongate, narrow, nasal snout, instead of near the point of the short snout, as they are in *S. maxima*.

WE have received a little book with a very long title, published by Messrs. Ward, Lock, and Tyler. It is called "Arcadian Walks and Drives in the North-west Suburbs of London, for the Pedestrian, Carriage, Horse, and Bicycle," and contains a variety of hygienic and other hints to pedestrians, and forty-two schemes of walks and drives in the north-west district, together with notes on the fauna, botany, &c., of the localities visited. This "booklet" would be much improved and rendered more generally useful by the addition of a map.

A GREAT deal of interest is attached to the last report of Dr. King, the superintendent of the Calcutta Botanic Gardens, for besides the usual details as to the exchange of plants and seeds with the Royal Gardens at Kew, and other similar colonial and foreign establishments—which exchange, by the way, has not been a light affair, inasmuch as from April 1873 to March 1874, 12,812 plants and 2,532 parcels of seeds were sent to various parts of the world—we have satisfactory accounts of the cultivation of the mahogany tree, the ipécacuanha, and the Para rubber tree. The former, as is well known, is a native of Central America and the West Indies; but there are, as Dr. King tells us, a good many old mahogany trees about Calcutta, which, however, rarely if ever yield perfect seed, so that fresh plants have been obtained direct from their native country. He says, further, that "it has been abundantly proved that the tree will thrive in most parts of Bengal, and, that the Indian grown timber is valuable." There are fine mahogany trees in the gardens at Saharanpore and Madras, and Dr. King doubts not that it will grow admirably in almost any part of India in situations free from frost, and where a little moisture can be secured in very dry weather. Of the few trees that were left in the Calcutta Botanic Gardens after the last cyclone in 1867, the mahoganies are by far the finest; they were planted about eight years since, and are now from 8 to 11½ ft. in circumference, 6 ft. from the ground. The quality of the wood of some of the trees blown down in the cyclones of 1864 and 1867 was found to be excellent. Such, then, are the prospects of the successful acclimatisation of one of the most valuable furniture woods known: so valuable indeed is it in European commerce, that about 40,000 tons are annually imported into Great Britain from Honduras, Jamaica, and San Domingo. So far as the increase of the ipécacuanha plants is concerned, the propagation by root and leaf-cuttings has been so successful that there is at present a stock of 63,000 living plants; whereas only four years since there were but twelve cuttings at the Cinchona Gardens, and seven out of these twelve were afterwards accidentally destroyed. Then again, with regard to the most valuable of all the india-rubber producing plants, namely, that of Para—the *Hevea brasiliensis*—six plants of which Dr. King took with him from Kew on his return to India in November last, we are told that already a few plants have been raised from cuttings taken from these six plants, and before the lapse of another year Dr. King hopes "to be able to report a considerable increase." The advantages to be obtained by the successful introduction of these trees into India are many, for besides the great superiority of the rubber

over that obtained from the East Indian figs, the principal of which is *Ficus elastica*, and consequently a higher market value, it will add to the Indian revenue by establishing a course of regular industry by a systematic tapping of the trees, and it will perhaps, to some extent, relieve the figs from a continued strain upon them, and probable future exhaustion.

IN a recently issued report on the trade and commerce of Java, we read that the total amount of Cinchona trees of all sizes and ages growing in Government plantations at the end of 1872 was 1,705,542, and the bark crop for the same year amounted to 18,000 kilogrammes.

It has recently been discovered that the bamboo contains a dangerous poison which the natives of Java extract from the cane in the following manner. The cane is cut at each joint, and in the cavity is found a certain quantity of small fibrous matter of a black colour, which is covered with an almost imperceptible coating of tissue which contains the poison. If swallowed the filaments do not pass into the stomach, but remain in the throat and produce violent inflammation and ultimately death. Experiments are to be made with various kinds of bamboo, to test the existence and nature of this alleged poison.

THE Syndicate appointed last June to collect information as to the space and accommodation required for a new Geological Museum have issued their report. They consulted the present Professor of Geology (Mr. Hughes), who considers it desirable that a very much larger number of specimens should be exhibited under glass than is the case at present; that there should be larger intervals in the arrangement of the collection; that more ample accommodation should be provided for students wishing to work at special points in detail, and for lecturers who wish to bring a class or private pupils; that work-rooms, class-rooms, and library, together with private rooms for the Professor and a Palæontologist, which are wholly wanting at present, should be provided. The estimated space for the museum and necessary offices would be 31,700 square feet. The Syndicate do not regard the estimate as excessive, and there is no difficulty respecting a site, as the ground of the old botanic garden affords one of sufficient dimensions in proximity to the other museums of natural science. The sum of 10,500*l.*, which has up to the present time been subscribed towards a new museum as a memorial to Professor Sedgwick, would be far from sufficient for the erection of a museum such as is indicated by Professor Hughes. The cost of such a museum, with suitable fittings and furniture for every department, could not be estimated at less than 25,000*l.* The Syndicate do not consider by the terms of their appointment that they are called upon to suggest any source from which this sum can be supplied.

THE "Origin of Species" controversy has been resumed by M. Blanchard, a member of the French Institute, in the *Revue des deux Mondes*. The learned naturalist supports strong anti-Darwinian theories.

A TELEGRAM from St. Petersburg has been received at Paris, stating that the Imperial Commission appointed to survey the Sea of Aral has finished its work. The level of that large inland sea is about 165 ft. above that of the ocean.

THE signature to the letter on "Supernumerary Rainbow," in NATURE, vol. x. p. 503, should not be Joseph, but Hugh Blackburn.

THE additions to the Zoological Society's Gardens during the past week include a Bonnet Monkey (*Macacus radiatus*) from India, presented by Mr. S. T. Hughes; a Black-backed Piping Crow (*Gymnorhina leucocota*) from South Australia, presented by Mr. F. Fuller; a Speckled Terrapen (*Clemmys guttata*) from North America, presented by Mr. A. B. Duncan; a White Stork (*Ciconia alba*), two Thicknees (*Edicnemus crepitans*), European, deposited.

## SCIENTIFIC SERIALS

THE *Journal of Mental Science*, October 1874.—This number opens with the address of Thomas Laws Rogers, M.D., president at the annual meeting of the Medico-Psychological Association, Aug. 6, 1874. His object was to procure a fixed meaning for the terms "restraint" and "seclusion," and the clear sense and practical aim of his remarks present a sharp contrast to the rather wandering discussion which followed.—Dr. J. Batty Tuke has a paper on a case in which the clinical history and *post-mortem* examination will, he thinks, support its being designated one of syphilitic insanity.—Dr. Daniel Hack Tuke writes about the Hermit of Red-Coat's Green, and finds him insane, an opinion from which there is little room for dissent. Probably also it would have been well had he individually "been put under the protection of the Lord Chancellor and the inspection of his visitors;" it "would have been better for the neighbourhood, better for his family, and better for the Hermit of Red-Coat's Green himself." But could not those very considerations be urged, and often with greater force, in favour of a curtailment of the liberty of thousands of frivolous, reckless, immoral persons, who are a far greater pest to their family and neighbourhood than poor Lucas was after he became the hermit?—Dr. H. Hayes Newtoning contributes a thoughtful paper On different forms of stupor.—In an interesting article on the mental aspects of ordinary disease, Dr. J. Milner Fothergill obtrudes his materialism in a way that will be distasteful to many, while to others the thing itself will appear shallow. Thought "is the product of the combustion of what was originally food." The brain of "Robbie Burns transmuted his oatmeal porridge into Tam O'Shanter."—In reviewing Dr. Maudsley's "Responsibility in Mental Disease," Mr. J. Burchell Spring, chaplain to the Bristol Lunatic Asylum, while doing justice to the ability of the work, seems to have the advantage of the author in matters of history. He very cleverly cuts away the ground from under Dr. Maudsley's rather uncalled-for assertion that the brutal treatment of the insane "had its origin in the dark ages of Christian superstition."

*Journal de Physique*, tome iii., No. 33, September.—This number commences with a description of the "phonoptometer" by M. J. Lissajous. This apparatus consists of an ordinary terrestrial telescope, of which the eye-piece is broken across, and the third lens from the eye (the one which inverts the image formed by the objective) attached to the prong of a tuning-fork. The lens is thus capable of vibrating in a vertical plane, the vibrations of the fork being maintained by an electro-magnet and contact-breaker. The telescope being directed to a distant object presenting a brilliant point, and the electro-magnet put into action, the point becomes a luminous vertical line if at rest, but if vibrating in a direction transverse to that of the motion of the lens, then the composition of the two movements gives rise to the well-known optical sound figures. The author claims for this ingenious instrument the power of determining the velocity of a luminous point on its trajectory, such as luminous projectiles, bolides, &c.—Theory of the phenomena of diffraction observed to infinity or in the focus of a lens, by M. J. Joubert.—On the mutual influence which two bodies vibrating in unison exercise upon one another, by M. A. Gripon. The author describes several experiments illustrating this remarkable action, employing for the purpose collodion membranes, which vibrate in unison with the column of air in the resonance boxes of tuning-forks, organ-pipes, &c. A small pendulum composed of a pith ball suspended by a thread of cotton is attached to such a membrane, and the system is then brought near the resonant case of a vibrating fork, with which the membrane is capable of vibrating in unison. The membrane vibrates strongly when at a distance of one metre, but when brought to within four or five centimetres of the mouth of the case, the sound of the latter undergoes a considerable weakening, and the pendulum of the membrane is scarcely moved. If the vibrations of the fork have but small amplitude, the proximity of the membrane to the resonant case extinguishes the sound altogether. None of these effects are produced if the membrane is not capable of vibrating in unison with the fork. If a membrane of a lower note is placed in front of the case and a current of warm air directed upon it, the weakening of the sound only occurs when the note of the fork is reached. Arrangements for repeating the experiments with organ-pipes are also described.—Graphic representation of the constants of voltaic elements, by M. A. Crova.—Some experiments concerning

the effects of magnetism on the electric discharge through a rarefied gas when the discharge occurs in the prolongation of the axis of the magnet, by MM. Auguste De la Rive and Edouard Sarasin. The authors employed in this research a columnar electro-magnet. The tube through which the discharge is transmitted rests on the upper extremity of the magnet, the line of electrodes being a prolongation of the axis of the magnet. Various gases sealed up in Geissler tubes have been experimented with, the discharge from a Ruhmkorff coil being allowed to traverse the gas. Changes occur in the appearance of the luminous discharge where the magnet is excited, these changes being accompanied by a change in the resistance offered to the current by the gas. Thus a tube containing hydrogen permitted the passage of an induced current marking 25° on the galvanometer when the magnet was not excited, but when excited the galvanometer reading was 40°. It seems to be a law that the augmentation in the intensity of the current is greater with a gas which is a good conductor than with one which is an inferior conductor of electricity. The authors confine themselves in this paper to a description of the facts without entering into theoretical considerations.—The number concludes with three papers reprinted from *Poggendorff's Annalen*: On the stroboscopic determination of the intensity of sounds, by E. Mach; Researches on magnetisation, by Holz; O. E. Meyer and F. Springmuhl, On the internal friction of gases.

*Zeitschrift der Oesterreichischen Gesellschaft für Meteorologie*, Oct. 15.—In an article on the state of development or forwardness of vegetation in Italy compared with that of Giessen, in Germany, Prof. H. Hoffmann expresses his regret that for the greater part of Italy we possess no observations of the kind to which he wishes to direct attention. A knowledge of the relative state of vegetation at many different places would help invalids to the choice of a residence congenial to them, and dispel the false estimates of Italian climate now so common. In the course of a rapid visit to Italy in March and April, 1874, he took a number of observations, and compared them on his return to Giessen with like observations simultaneously taken at that place. The weather was fortunately fine and fairly uniform over Central and Southern Europe during the period of his travels. The average state of vegetation in open situations can be roughly calculated under normal conditions by reckoning for every degree southwards an advance of 3½ days. Direct observation shows this rule generally to hold good. Rome is 8° south of Giessen, Naples 9°; this gives, at the rate above mentioned, an advance for Rome of 30, for Naples of 34 days. On looking at the map which accompanies Prof. Hoffmann's paper, we find the real difference to have been for Naples 35; for Rome 23; and so with many other places in Italy. If we have the number of days' advance in the spring, by doubling it we obtain the relative length of summer, or the period of vegetation. The Riviera di Ponente is quite abnormal, having a warm and early spring. Prof. Hoffmann's method consisted in taking the mean of the number of days' advance before Giessen, of the bursting into leaf or flower of several common kinds of trees in a certain place, and making this number the criterion of climate. In conclusion, he affirms that the extended observation of a single species of tree in the above manner, with regard also to the time of first fruits, would give us a new insight into comparative climatology, and that after various species had been so dealt with, maps might be made, exhibiting for each month a fair example in the development of one of these species. A list of the plants observed is appended. Among the *Kleinere Mittheilungen*, in a communication from Dr. Hildebrandtson, director of the Meteorological Department of Upsala Observatory, we find that he arrives at results similar to those of Mr. Ley respecting the movements of cirrus, this cloud appearing to move away from the centre of a cyclone and towards the centre of an anticyclone.

## SOCIETIES AND ACADEMIES

MANCHESTER

Literary and Philosophical Society, Oct. 20.—Edward Schunck, F.R.S., president, in the chair.—E. W. Binney, F.R.S., stated that he had been so fortunate as to find a specimen of *Stigmara* which he exhibited to the Society, from the bullion coal at Clough Head, near Burnley, having the medulla perfectly preserved.—Mr. R. D. Darbishire, F.G.S., exhibited and described the Palaeolithic (French and English drift) implements collected

for the *soirée* at the Owens College.—Prof. Boyd Dawkins, F.R.S., brought before the notice of the Society the conditions under which the palæolithic implements are found in the river-strata and in the caves, in association with the extinct mammalia, such as the mammoth and woolly rhinoceros. Although the number of flint implements from the river-strata in various collections was very great, yet it is small when viewed in connection with the enormous quantity of gravel removed in their discovery. They are not evenly distributed, but cluster round certain spots. Their discovery in India along with the extinct mammalia proves that man was living, both in Europe and in Southern Asia from the Ganges to Ceylon, in the same rude uncivilised state, at the same time in the life-history of the earth. He also called attention to the art of the hunters of the reindeer and mammoth in the south of France, Belgium, and Switzerland, an art eminently realistic, and by no means despicable; and he inferred from their art and implements and the associated animals that they may be represented at the present day by the Eskimos.—On a colorimetric method of determining iron in waters, by Mr. Thomas Carnelly, B.Sc.; communicated by Prof. H. E. Roscoe, F.R.S.

PHILADELPHIA

Academy of Natural Sciences, June 23.—Dr. Ruschenberger, president, in the chair.—Mr. B. Waterhouse Hawkins gave his views on the construction of the pelvis of *Hadrosaurus*.—Prof. Cope described a species of Dipnoan fish of the genus *Ctenodus*, from the coal measures of Ohio.

June 30.—Dr. Ruschenberger, president, in the chair.—Anatomical notes by Dr. Chapman were read, on the disposition of the *Latissimus Dorsi*, &c., in *Ateles Geoffroyi* and *Macacus rhesus*, and on the *Flexor Brevis Digitorum* in *Ateles Geoffroyi*.

On report of the committee to which it was referred, the following paper was ordered to be published:—"On habits of some American species of birds," by Thomas G. Gentry.

July 7.—Dr. Ruschenberger, president, in the chair.—Prof. Persifer Frazer, jun., continued the account of his attempts to reconcile the results of the analyses of minerals by the best chemists with formulas which were constructed on the doctrine of quantivalence, *i.e.*, the known atom-saturating power of the elements.—On change of habit in *Smilacina bifolia*. Mr. Thomas Meehan stated that he had recently seen a case where the stolons had advanced from the ground, and up the trunk of a large chestnut tree, to the height of about 2 ft.; the original stolons for several years back having died away, and the plant taken in a purely epiphytial character. The roots and stolons mostly had penetrated the coarse rough bark of the chestnut tree, the leaves only being chiefly visible.

July 14.—Dr. Ruschenberger, president, in the chair.—Prof. Cope stated that the snakes of the genus *Storeria*, B. and G., are viviparous like *Eutania* and other protonotian genera to which they are allied.—Prof. Cope gave a synopsis of the result of his work in connection with Hayden's United States Geological Survey of the Territories during the season of 1873. He stated that the investigation covered principally the palæontology of the Cretaceous, Eocene, Miocene, and Pliocene periods in Colorado. The whole number of species of vertebrata obtained was 150, of which 95 were at the time new to science. The Cretaceous species were both terrestrial and marine, and the Miocene were most numerous. These numbered 75 species, of which 57 were new.

PARIS

Academy of Sciences, Oct. 19.—M. Bertrand in the chair.—The following papers were read:—On series of similar triangles, by M. Chasles.—Observation of the solar eclipse of Oct. 10, 1874, with the spectroscope; tables of the observations of solar prominences from Dec. 26, 1873, to Aug. 2, 1874, by P. Secchi.—On the dissociation of hydrated salts, by M. H. Debray. This is a reclamation of results published by M. G. Wiedermann in a memoir "On the dissociation of the hydrated sulphates of the magnesium group."—On magnetic condensation in soft iron, by M. A. Lallemand. The author describes a series of experiments illustrating this property of soft iron. The condensation appears to depend on the intensity of the magnetism developed in the iron.—Hypothesis of the imponderable ether, and on the origin of matter, by M. Martha-Lécker.—On the distribution of the sugar and mineral principles in beet, by M. Ch. Violette. The author has arrived at the following conclusions:—1. The proportions of sugar contained in the sacchariferous and cellular tissues of beet differ but little. 2. The sugar increases in arithmetical progression along the axis of the root, from the upper extremity to the tip. 3. The mineral con-

stituents do not undergo any regular variation along the axis, but chlorides are more abundant towards the upper extremity than at the tip. 4. Mineral constituents are more abundant in the cellular than in the sacchariferous tissues. 5. Chlorides are considerably more abundant in the cellular than in the sacchariferous tissues. 6. The chlorides are more liable to variation in the two kinds of tissues than the other mineral principles.—Experiments on the circular compass made on board the despatch-ship *Faon* and the armour-plated frigate *Savoie*, by M. E. Duchemin.—Remarks concerning recent notes by MM. Signoret and Lichtenstein on the different known species of the genus *Phylloxera*, by M. Balbiani. The author points out that *P. Lichtensteini* recently described by him is specifically distinct from *P. Rileyi*, and again restates his belief that the species seen by M. Lichtenstein on *Quercus coccifera* was not *P. vastatrix*.—Observations relating to a recent note by M. Rommier "On experiments made at Montpellier on phylloxerised vines with M. Petit's coal-tar," by M. Balbiani.—Influence of temperature on the development of *Phylloxera*; extract from a letter from M. Maurice Girard to M. Dumas. Other communications relating to *Phylloxera* were received from various authors.—Generalisation of Euler's theorem on the curvature of surfaces, by M. C. Jordan.—Observations relating to a recent note by M. Lecoq de Boisbaudran on supersaturation, by M. D. Gernez.—Researches on the decomposition of certain salts by water, by M. A. Ditte:—When water is added to a solution of mercuric sulphate a basic sulphate is precipitated. This basic salt forms the subject of the present research.—The colouring matter of the blood (hæmatosine) contains no iron, by MM. C. Pagnelin and L. Jolly. The authors describe the preparation and purification of hæmatosine. By repeated macerations with alcoholic ammonia and subsequent filtration, hæmatosine is at length obtained completely free from iron.—On the movement excited in the stamens of *Synanthèreæ*, by M. E. Heckel.—M. F. Garrigou communicated an analysis of the stalaclitic deposits found in the chimneys of iron forges.—During the meeting M. Le Verrier presented the meteorological atlas of the Observatory of Paris, containing observations for the years 1869, 1870, and 1871.

BOOKS RECEIVED

ENGLISH.—Elementary Treatise on Practical Chemistry: Frank Clowes, B.Sc. (Churchill).—Animal Mechanism (International Series): E. J. Macey (H. S. King and Co.).—A Treatise on Magnetism: H. Lloyd, D.D. (Longmans).—Brinkley's Astronomy: Stubbs and Brinnow (Longmans).—A Peep at Mexico: J. L. Geiger, F.R.G.S. (Trübner).—Pharmacographia: Flückiger and Hanbury (Macmillan).—Cave Hunting: W. B. Dawkins (Macmillan).—Telegraph and Travel: Col. Sir F. J. Goldsmid, C.B., K.C.S.I. (Macmillan).—Sun and Earth great Forces in Chemistry: T. W. Hall, M.P., L.R.C.S.E. (Trübner).—Magnetism: H. Lloyd, M.D., D.C.L. (Longmans).—The Protoplasmic Theory of Life: L. Beale (Baillière and Co.).—Leeds Philosophical and Literary Society, Annual Report, 1873-74.—Fiske's Cosmic Philosophy (Macmillan and Co.).

AMERICAN.—Butterflies of North America, Parts I. and II.: W. H. Edwards (Hurd and Houghton, New York).

FOREIGN.—Atti della Reale Accademia Dei Lincei, vol. xxvi.—Mémoire sur la maladie de la Vigne, et sur son traitement: Louis Faucon (Paris).—Etudes sur la nouvelle maladie de la Vigne: Maxime Cornu (Paris).—Etudes sur la nouvelle maladie de la Vigne dans le Sud-Est de la France: M. Duclaux (Paris).—Les Arachnides de France: Eugène Simon (Paris).—Anthropogonie: Ernst Haeckel (W. Engelmann, Leipzig).

COLONIAL.—Elementary Dynamics: W. G. Willson, M.A., &c. (Thacker and Co., Calcutta).—Report of the Meteorological Reporter to the Government of Bengal: H. F. Blandford (Calcutta).—Patents and Patentees: W. H. Archer (Melbourne).

CONTENTS

	PAGE
THE PROSPECTS OF THE ENDOWMENT RESEARCH . . . . .	1
GRESHAM COLLEGE . . . . .	2
HAECKEL'S DEVELOPMENT OF MAN . . . . .	4
LETTERS TO THE EDITOR:—	
Migration of Birds.—Prof. ALFRED NEWTON, F.R.S. . . . .	5
Insects and the Colour of Flowers.—Lord RAYLEIGH, F.R.S. . . . .	6
Sounding and Sensitive Flames.—Prof. A. S. HERSCHTEL . . . . .	6
A New and Simple Method for making Carbon Cells and Plates for Galvanic Batteries.—W. SYMONS . . . . .	8
Ingeny in a Spider.—JOHN FOPHARD . . . . .	8
Note on the <i>Rhynchosaurus Ariceps</i> , Owen.—Dr. T. OGER WARD . . . . .	8
THE ALPINE CLUB MAP OF SWITZERLAND . . . . .	8
REPORT OF PROF. PARKER'S HUNTERIAN LECTURES "ON THE STRUCTURE AND DEVELOPMENT OF THE VERTEBRATE SKULL," VIII. SKULL OF THE COMMON FOWL ( <i>With Illustrations</i> ) . . . . .	9
THE NEW VINE-DISEASE IN THE SOUTH-EAST OF FRANCE, II. ( <i>With Illustration</i> ) . . . . .	11
EARLY OPENING OF NEW GARDENS . . . . .	14
THE GEOGRAPHICAL DISTRIBUTION OF AURORE . . . . .	14
EDWIN LANKESTER, M.D., F.R.S. . . . .	15
NOTES . . . . .	16
SCIENTIFIC SERIALS . . . . .	19
SOCIETIES AND ACADEMIES . . . . .	19
BOOKS RECEIVED . . . . .	20

THURSDAY, NOVEMBER 12, 1874

## SIR JOHN LUBBOCK AT BIRMINGHAM

SIR JOHN LUBBOCK, in his inaugural address as president of the Midland Institute, gave utterance to some wholesome truths which we sincerely hope the Government and people of the country will take to heart. Sir John, as a member of the Schools Commission and of the Science Commission, has had ample opportunities of ascertaining the exact state of our schools and universities as to the teaching of science; and after all that has been said and done, he comes to the unhappy conclusion that, practically, science is ignored in the vast majority of our educational institutions of all classes—elementary schools, endowed schools, and universities. At the same time he is driven to the conclusion that a widespread interest in science already exists in the country. Of this we think anyone can assure himself who looks around and can read the signs of the times. There is undoubtedly a widespread feeling that the present all but universal system of education is inadequate and unsatisfactory and that science must, sooner or later, be allotted a place in all our schools. Notwithstanding this feeling, the fact undoubtedly remains as Sir John Lubbock stated it, that the great fault of our present system of education is the neglect of science; some few years hence it will be deemed incredible that a boy should be allowed to pass through any good school and yet be entirely ignorant of any one branch of natural knowledge.

Here, then, on one side exists a craving, becoming more and more defined, in the country, that science be given a place in our educational system, and on the other hand the fact that scarcely anything definite has yet been done to give science an established place in our schools and universities. In most cases where science has been admitted into our schools, it has been only on sufferance as a kind of interloper for which any odd corner is good enough. In spite of all that has been said recently—again to refer to the address—about the advantage of science, notwithstanding the reports of Royal Commissions and the action of Parliament, though the importance of science is generally admitted, still it is unfortunately the case that, with a few exceptions, it is either entirely ignored in our endowed schools or has allotted to it a space of time ludicrously inadequate, and, indeed, almost nominal. In some cases it is permitted, but only on condition of being taken out of playtime, which is not fair to the boy, and being paid for extra, which naturally does not recommend it to the parent. It is for parents and for the public to say whether this state of things is satisfactory; and Sir John called attention to it because he thought that parents were in general scarcely aware how little their sons were even now learning beyond the old routine. The present state of matters ought not, therefore, to be tolerated, and the only position in our schools and universities, for the teaching of science, is a position of, at least, equality with all the other old-fashioned means of education. The only principle on which a satisfactory course of education can be constructed is, that it is essential for the well-being of every man and woman that he

and she should start in life with a well-trained mind and a fair knowledge of the principles and the main facts of everyday life.

Sir John Lubbock admits the importance of language as a means of education, but he thinks that it has hitherto been given a far too prominent place in our schools, and that the amount of time devoted to linguistic studies is out of all proportion to the results achieved. "We still," he said, "indeed, teach the Latin grammar rather than the Latin language, for a man cannot surely be said to know a language which he cannot speak; and I cannot but believe that if our children were taught Latin and Greek as they are taught French and German, they would learn them in half the time. Mr. Arnold, in his report on German schools, tells us that it is common there for the master to address his boys in Latin, and for the class to speak Latin in reply. The German boys, he adds, have certainly acquired through this practice a surprising command of Latin."

It is well known that scholarship in Germany is far more widespread and accurate than in England, and we see that this scholarship is acquired with a much less expenditure of time. The consequence is, that plenty of time remains in German schools for the teaching of science, which forms so important a part of education throughout that country, and which gives the German a starting-point in life so very much superior to that which the average Englishman has, even when educated at our public schools and universities. No one can deny the increasing importance of a knowledge of science in all departments of human activity, and we fear that if another two generations of boys be allowed to pass through our schools in their present condition, this country will be almost hopelessly behind certain countries on the Continent. This has been recently admitted as a truth by several practical men, whose position as such ought to be of some weight with our trading and manufacturing community. But to this subject we hope to return in an early number.

In the meantime, it is clear to all who have taken pains to inquire into the facts that a radical reform must soon be made in our present system of education, from the elementary schools upwards; that a rearrangement of subjects and a reform in methods must be made, so that science may be allotted a place of equal prominence with other subjects, and that Government must begin the reform by insisting that such a change be made in the programmes of all schools under its control. On this point Sir John said:—

No doubt we had greatly increased the number of our schools and the attendances of the children, but while we had been disputing over the 25th clause and arguing about compulsion, we had somewhat lost sight of the character of the education given; and he was sorry to say that there was abundant evidence, not only that it had not improved, but even that it had fallen off in the last few years. The present system of payment practically confined the instruction given to reading, writing, and arithmetic. No doubt a payment of 3s. per head was nominally offered for any two other subjects, but other grants amounted to 18s.—namely, 5s. for attendance, 1s. for music, and 4s. each for reading, writing, and arithmetic, which were obligatory. Now, as 15s. was the maximum granted, it followed that if three-quarters of the children pass in reading, writing, and arithmetic, the



full grant would be earned, and nothing could be obtained from other subjects. It seemed to him, however, that the passes in reading and writing ought not to be made so difficult, but that three-quarters of the children should pass. No wonder that under those circumstances the Duke of Devonshire's Commission had reported that the present system had "unfortunately narrowed the instruction given in elementary schools, and, together with the lower standard consequently adopted in the training and examination of pupil-teachers, and the curtailment of the syllabus of the training colleges, exercises a prejudicial effect on the education of the country."

As to the question of expense for apparatus, Sir John Lubbock showed that this need be no obstacle; fully recognising that the kind of science to be taught must be no word knowledge, but a practical acquaintance with the actual facts of nature.

Schoolmasters had on more than one occasion said to him that it was impossible for them to teach science, because they had not the funds necessary to purchase apparatus, set up a laboratory, &c. Now, no doubt, much money might be profitably laid out in this way, but it was not necessary to do so. Mr. Tuckwell, who spoke from personal experience, said in a paper read before the British Association in 1871, that "it ought to be more widely known for how very small a sum sufficient apparatus can be obtained to teach natural history and experimental science. A laboratory can be fitted up for twenty boys at a cost of little more than 20*l.*, while each boy's private stock of glass and test solutions need not cost more than 8*s.* per annum. Botanical flower-trays, containing eighteen bottles, may be bought for half-a-crown; electrometers, telescopes, polariscopes, models of pumps, and pulleys, may be made, by a little instruction, by the boys themselves, who will learn in their construction far more of the principles which they involve than could ever be instilled into their minds by the choicest products of the shop."

After quoting the opinions of the late Prof. Faraday, Prof. Henslow, Dr. Hooker, and Prof. Huxley on the importance of early scientific education, Sir John said it was often urged that in science the very methods of teaching were still under discussion. This, however, was an unavoidable incidence of a commencement. It would be remedied by experience, and could be remedied by experience only. Mr. Arnold truly said that "when scientific physics have as recognised a place in public instruction as Latin and Greek, they will be as well taught."

Sir John Lubbock also referred to the miserable pittance which has as yet been allotted to research in science by our Universities; but as we have referred to this point so recently, we need not dwell upon it here. Altogether, we hope that this moderate and wise, but uncompromising address may give one more strong impulse to the already widespread feeling that we cannot with safety delay much longer in giving to science the place which it ought to hold in the educational system of the country.

#### THE NATURAL HISTORY OF SPITZBERGEN AND NOVA ZEMBLA\*

SO much public attention is now directed to the polar regions and their inhabitants, that we do not hesitate to bring before the notice of our readers the important contribution to our knowledge of Spitzbergen and Nova Zembla, recently published by Von Heuglin as

\* "Reisen nach dem Nordpolarmeer in den Jahren 1870 und 1871," von M. Th. von Heuglin. In drei theilen. Dritter Theil: Beiträge zur Fauna, Flora, und Geologie. (Braunschweig, 1874.)

the third part of his "travels" in those countries in 1870 and 1871.

In it will be found a complete *résumé* of the present state of our knowledge of the zoology and botany of those distant and inhospitable regions, and a chapter on what is known of their geology.

The mammals of these northern climes are few in number, consisting chiefly of seals and whales. The terrestrial mammal-fauna comprehends only two species of lemming (*Myodes torquatus* and *M. obensis*): the arctic fox, common fox, and wolf and sea-bear among the carnivores, and a single ruminant—the reindeer—seven species in all. The birds are more numerous, though here again the marine species far predominate, the land-birds being only ten in number out of a total of fifty. Amongst the former we are surprised to see recorded as an accidental visitor the Hoopoe, usually considered as rather an inhabitant of the tropics, but of which a single straggler was captured in Southern Spitzbergen by a merchant-vessel in August 1868. Reptiles are conspicuous only by their absence in Spitzbergen and Nova Zembla, but of fishes thirty species are recorded as having been obtained on various parts of the coast, all belonging to known forms either of the Atlantic or of the waters of Northern Asia.

The invertebrates of Spitzbergen are treated of more concisely by Herr v. Heuglin; but lists are given of the species of the different orders, and many references to previously published papers and works bearing upon this subject are added.

The account of the flora of Spitzbergen is mainly founded on Malmgren's paper, published in 1862, in the Proceedings of the Royal Academy of Sciences of Stockholm, to which, however, additions have since been made by Anderson, Fries, and Nyström. The Phanerogams enumerated are 117, the Cryptogams upwards of fifty. The botany of Nova Zembla and Waigatsch Island is separately treated of. Our knowledge of this subject is based upon the excellent researches of Von Baer and Trautvetter, published at St. Petersburg, and a paper of Blytt's, of Christiania. On these islands 146 Phanerogams and 144 Cryptogams have been discovered. Among the latter a certain number of new species are described in the present work by Prof. Ahle, of Stuttgart.

The geological chapter, which concludes the volume, is based upon the well-known researches of the Swedish naturalists Lovén, Torell, Blomstrand, and Nordenskiöld, who have laboured so long and so diligently upon this subject.

We can recommend Herr v. Heuglin's work as a very convenient handbook for the use of future visitors to the Northern Seas, and of explorers of those newly discovered lands of which we are now hearing so much.

#### HÆCKEL'S DEVELOPMENT OF MAN\* *Anthropogenie oder Entwicklungsgeschichte des Menschen; gemeinverständliche wissenschaftliche Vorträge, von Ernst Hæckel. (Leipzig: Engelmann, 1874.)*

##### II.

IN tracing the genealogy of our race, Prof. Hæckel, while availing himself of the gradual changes in the fauna of the earth during geological periods, and of the

\* Continued from p. 5.



gradation of living animal forms, takes as the most important clue in his difficult task the facts of human embryology. This close connection is constantly kept in view, and by its aid not only does he trace, as in the twenty-second chapter of his "Schöpfungsgeschichte," the philogeny of man as a compound organism (*Person*), but extends the same process to the separate organs of the human body and the faculties of the human mind. The chapters which are occupied by this investigation are the most interesting in the book, full of ingenious suggestions, and well repaying the reader who brings a sound knowledge of embryology and comparative anatomy to their study.

The genealogical tree here constructed is briefly as follows:—First, a Cytthode (*Mouër*), itself the product of inorganic matter, passed in the Laurentian ages from being a component of primordial sea-slime (*Plasson*), represented by existing *Batlybius* to a separate unicellular or amœboid form. Several of these plastids next formed a colony by cell-division (*Morula*), which in subsequent ages became covered with cilia, differentiated into an ectoderm and endoderm, and provided with a mouth (*Gastrœa*), a form represented in sponges and other invertebrates and in Amphioxys, but omitted in the ontogenesis of man, or represented by the Blastosphere. Each of the primitive layers subdivided into two, and between the latter was formed the *calium*, or body cavity (vermiform stage, protuchous or aptochous). Next was developed the notochord in a form related to the existing ascidian and amphioxus larvæ. The vertebral character being thus attained, our ancestors passed through stages now represented by the lampreys and the sharks, during the ages which ended the archæolithic period. While the Devonian, Carboniferous, and Permian formations were taking place, the Amphibian stage was passed, and the succeeding development in the Trias epoch was from this to a protamnionic form, distinct from that which gave birth to the sauropsidan stem, and leading directly to the mammalian. When the last strata of chalk had been laid down, a marsupial form was changing into one now represented by the lemurs. Lastly, the Tertiary period witnessed the development of various gradations of catarrhine Primates, from one of which the earliest men directly sprung.

The genealogy thus constructed (which is almost exactly the same as those Prof. Hæckel has before published) is plausible enough, and if such speculations come under what the late M. Elie de Beaumont called "la science mousseuse," they certainly have their use in directing and stimulating inquiry. But is this the way to introduce the results of biology to a popular audience?

In the first place, the theory of evolution itself is neither so certain nor so complete as persons who take their knowledge from these lectures alone would be led to suppose. Our author is astonished at Rüttimeyer's comparison of "Darwinism" to a religion. But as held by its illustrious author and by the ablest biologists both in Germany and England, it is very much like a rational theology: for it is a theory which only pretends to be a more or less probable explanation of facts, which is held liable to correction from fresh facts and with tolerance for less probable explanations. But in these lectures evolu-

tion is no longer a reasonable belief, but a fanatical and intolerant *Aberglaube*.

Again, granting that evolution by some means has taken place, and that natural selection is a true cause of evolution, it is not the only cause. Modifications of it, like the so-called "Mimicry" of Bates and Wallace, have already been discovered, and no doubt others will be. The effect of Sexual selection, a struggle for existence of the race as distinct from the individual, would not have been guessed had not Mr. Darwin himself proved it: and it often modifies the working of Natural selection.

Lastly, if we accept evolution and so-called materialism in its widest sense, the logical results will not be what Prof. Hæckel assumes. For these, like all other scientific theories, deal only with secondary causes; and when we have traced back mind and matter alike to cosmic vapour, the question still recurs, to what was that matter with its potential functions due? In *Protogenes*, or in the impregnated human ovum,

The thread of Life untwisted is  
Into its first consistences.

Yet the mysteries of growth, of movement, and of generation are not less but more mysterious than when less nakedly exposed in higher organisms. Scientific investigation, in the hands of Darwin, Fritz Müller, Dohrn, and Hæckel, has told us much and will tell us more of how this world has come about; but when men cease to inquire into its final cause, the human race will have made a step back towards its primordial slime.

Leaving these general considerations, one is reminded by Prof. Hæckel's attempt at a human philogeny of the many fallacies which beset the application of the general theory of evolution to this particular instance.

When the dogma is accepted that "ontogeny is a recapitulation of philogeny," we find that the individual development of man and his ancestors is far from completely known. The embryology, for instance, of Monotremata and the Ganoids, including *Ceratodus*, is a blank. Only the other day Mr. Balfour's admirable observations on the development of sharks came to disturb what seemed to be a universal law of vertebrate embryology, and the origin of the urogenital organs is still confessedly obscure. Yet Prof. Hæckel, while candidly admitting this last difficulty, practically assumes one and not the best-supported view to be correct. On the strength of it he teaches that the kidneys are homologous with sebaceous glands, with the segmental organs of Annelata,\* and with the water-vascular canals of other worms; and that sperm-cells belong to the exoderm, germ-cells to the endoderm. Again, the placental classification which forms the basis of the genealogical tree on p. 493 has been always open to grave objection, and has now been decisively contradicted by the researches of M. Alphonse Milne-Edwards and Prof. Turner.

Again, even when the development of an animal is fully made out, it is often so abridged and distorted an epitome of its ancestry, that we may easily interpret it wrongly, and we have at present no signs to tell us when the clue begins to fail.

But a third and still more serious difficulty in constructing philogenies is the well-known incompleteness

\* Whether this ingenious hypothesis of Gegenbaur will be confirmed on other grounds is, of course, a different question.

of the geological record; and, unluckily for the genealogy of man, the very chapter we most need, that of the Worms and primitive Tunicata, is the one most hopelessly lost.

All this does not prove that no attempt should be made to trace back the descent of man and other animals by such lights as we have, but it does seem to show that the results are too uncertain to be set forth as ascertained facts in popular lectures.

Strange as it now seems, a generation ago many of the best zoologists spent their time in arranging animals according to various systems of metaphysical origin. The speculations of Oken and Geoffrey St. Hilaire, of Forbes and Macleay, read now like the controversies of the schoolmen. The archetypal skeleton was drawn in many forms (and often in several colours), and almost as many compound terms were invented as those of Prof. Hæckel; but all these fancied systems have passed away, or only exist as relics to encumber the ground. Does not their fate suggest misgivings as to the fate of the genealogical trees which are now so luxuriant?

In conclusion I will quote the words of one who will not be suspected of sharing the prejudices of those ecclesiastical newspapers which appear to be responsible for many of the defects in Prof. Hæckel's lectures.

"Of all kinds of dogmatism the materialistic is the most dangerous, because it denies its own dogmatism, and appears in the garb of science; because it professes to rest on fact, when it is but speculation; and because it attempts to annex territories to the domain of Natural Science before they have been fairly conquered."\*

P. H. PYE-SMITH

### ISMAILIA

*Ismailia: a Narrative of the Expedition to Central Africa for the suppression of the Slave Trade, organised by Ismael, Khedive of Egypt.* By Sir Samuel W. Baker, Pacha, F.R.S., &c. &c. Two vols. (London: Macmillan and Co., 1874.)

IT must be difficult for any unhardened critic to keep his wits about him in reading this fascinating narrative, and we are sure no reader will wish that it had been shorter.

There is not much in the book of directly scientific interest. Sir Samuel went over very nearly the ground he had traversed before, and which he has so well and fully described in his "Albert N'yanza" and "Nile Tributaries of Abyssinia;" and he kept so faithfully and unswervingly in view the noble errand on which he set out, that he had little opportunity to attend to the interests of science. The heroic Lady Baker, however, made large botanical collections throughout the journey, which she presented to the Khedive on her arrival in Cairo, and Sir Samuel informs us that Lieut. Baker made considerable topographical observations. Moreover, although the expedition had no scientific object in view, its purpose was eminently conducive to the interests of

science, seeing that until the demoralising traffic in slaves is suppressed, we can never hope to obtain a thorough knowledge of the interesting region around the Upper Nile—of its geography, its ethnology, and its natural history; and therefore, although the great object which Baker had in view seems to have been thwarted through the pusillanimity of the Egyptian Government, he deserves the greatest credit for having proved that with skill, determination, and adequate means—and his means were very inadequate—the journey from Cairo to the Albert N'yanza might be accomplished in a very short time.

We think it would be difficult to conceive of a leader better fitted than Sir Samuel Baker to accomplish the task which the Khedive commissioned him to do. His work is a practical commentary on the vigorous and truthful lines of Tennyson:—

"O well for him whose will is strong!  
He suffers, but he will not suffer long;  
He suffers, but he cannot suffer wrong:  
For him nor moves the loud world's random mock,  
Nor all calamity's hugest waves confound,  
Who seems a promontory of rock,  
That, compass'd round with turbulent sound,  
In middle ocean meets the surging shock,  
Tempest-buffeted, citadel-crown'd."

Sir Samuel estimates that at least 50,000 persons are annually captured to be sold as slaves, and it would be safe to say that several thousands more are massacred in effecting the capture of these; the atrocities practised by the slave-hunters are almost incredible. It was to suppress this lamentable state of matters that Sir Samuel Baker was commissioned, on April 1, 1869, by the well-intentioned and enlightened Khedive of Egypt, who gave him full powers as to equipment. To accomplish this purpose it was necessary to annex the whole Nile basin, and to establish a legitimate trade in the barbarous countries which had hitherto been scourged with this infamous traffic. So far as Sir Samuel could carry out his plans, the equipment of the expedition was admirable in every detail, down to the magic lantern, the wheels of life, and the magnetic battery, which last was in constant requisition among the tribes of the Upper Nile, and was a perpetual source of amusement to the members of the expedition and of wonder to the natives.

It would be impossible, in the space at our disposal, to give any adequate idea of the work of the expedition. From the very first Sir Samuel met with obstructions and delays that would have induced any less patient and less determined man to abandon it altogether. The Egyptian Government had undertaken to furnish a large number of boats, besides steamers and an adequate military force, for the expedition, which, it was arranged, would start in June 1869. It was with the greatest difficulty that a start was made on the 29th of August, when two of the parties proceeded up the Nile, one to go direct by river to Khartoum, and the other to land at Korosko and march across 400 miles of desert to the same place; with the latter was the heavy machinery and sections of steamers carried by a regiment of camels. Sir Samuel himself set out from Suez on Dec. 11 for Souakim, thence to Berber on the Nile, and in a diabbeeah to Khartoum. Here, in accordance with orders which had been sent on months before, he expected a fleet of vessels to be ready

\* I have endeavoured to represent the sense of the following passage from Virchow ("Gesammelte Abhandlungen," p. 18):—"Es giebt einen materialistischen Dogmatismus so gut wie einen kirchlichen und einen idealischen, und ich gestehe gern zu dass der eine wie die anderen reelle Objecte haben können. Allein sicherlich ist der materialistische der gefährlichere weil u. s. w."

to convey the expedition up the Nile, but was coolly informed by the Governor-General that "it was impossible to procure the number of vessels required; therefore he had purchased a house for me, as he expected I should remain that year at Khartoum, and start in the following season."

This was certainly disheartening; it was evident that the expedition was unpopular, and that although the Khedive earnestly wished the suppression of the trade, there was scarcely another man in the country but thought it was his interest to support it; thus the queller of the evil had to fight against tremendous odds. After inconceivable difficulty a small fleet was got together, a force of 1,400 infantry and two batteries of artillery mustered, and everything ready for a start by Feb. 8, 1870, although the desert party under Mr. Higginbotham had not yet come up. Out of the military force, Baker selected forty-six men, who were known as the "Forty Thieves," owing to their light-fingered propensity, of which, however, they were soon cured, and became ultimately a loyal band of well-disciplined braves, who contributed greatly to the success of the expedition.

On Feb. 16 the expedition reached the Sobat junction, which river brings an immense body of yellowish water to the Nile, colouring the latter for a great distance. The Bahr Giraffe was reached next day, and here the expedition met with new difficulties which seemed likely enough to compel it to turn back. Sir Samuel says—

"The Bahr Giraffe was to be our new passage instead of the original White Nile. That river, which had become so curiously obstructed by masses of vegetation that had formed a solid dam, already described by me in 'The Albert N'yanza,' had been entirely neglected by the Egyptian authorities. In consequence of this neglect an extraordinary change had taken place. The immense number of floating islands which are constantly passing down the stream of the White Nile had no exit; thus they were sucked under the original obstruction by the force of the stream, which passed through some mysterious channel, until the subterranean passage became choked with a wondrous accumulation of vegetable matter. The entire river became a marsh, beneath which, by the great pressure of water, the stream oozed through innumerable small channels. In fact, the White Nile had disappeared. A vessel arriving from Khartoum in her passage to Gondokoro would find, after passing through a broad river of clear water, that her bow would suddenly strike against a bank of solid compressed vegetation—this was the natural dam that had been formed to an unknown extent: the river ceased to exist.

"It may readily be imagined that a dense spongy mass which completely closed the river would act as a filter: thus, as the water charged with muddy particles arrived at the dam where the stream was suddenly checked, it would deposit all impurities as it oozed and percolated slowly through the tangled but compressed mass of vegetation. This deposit quickly created mud-banks and shoals, which effectually blocked the original bed of the river. The reedy vegetation of the country immediately took root upon these favourable conditions, and the rapid effect in a tropical climate may be imagined. That which had been the river bed was converted into a solid marsh.

"This terrible accumulation had been increasing for five or six years, therefore it was impossible to ascertain or even speculate upon the distance to which it might extend. The slave-traders had been obliged to seek another route, which they had found *via* the Bahr Giraffe, which river had proved to be merely a branch of the White Nile, as I

had suggested in my former work, and not an independent river."

On Feb. 18 the fleet commenced to push its way against the strong current of the Bahr Giraffe, but had not made much progress when it was met by obstructions which had shut up the original channel; day after day was the river found to be choked up with a mass of vegetation—"sudd," Sir Samuel calls it—which with infinite labour had to be cleared away by all hands working with cutlasses and knives, to allow the vessel to pass through. The cutting through of this was dreadfully trying to the men; the poisonous effluvia permanently disabled many; it was, besides, a sore hindrance to the progress of the expedition. The end of it was that Sir Samuel was compelled to turn back and wait for a more favourable season when the river would be in stronger volume. The retreat was commenced on April 3. The distinguishing feature of the country at this part of the Bahr Giraffe is the innumerable hills of the white ant, rising to heights of 8 and 10 ft., and numerous herds of the antelope *Damalis senegalensis* are met with.

A very well-organised encampment was formed some distance below the Sobat junction, which ultimately developed into a pretty town and busy market-place, to which Sir Samuel gave the name of "Tewfikkeyah."

A start was again made on Dec. 11, and after scarcely less labour, which disheartened and told on the health of nearly everyone but Baker himself, who seems throughout to have had a charmed life, the broad bosom of the great White Nile was reached on March 11, 1871, and the fleet arrived at Gondokoro on April 5, having taken twenty months to do what on Sir Samuel's return journey was easily accomplished in three. The powers of Baker Pacha were by his commission to expire in four years from April 1869, so that he had now only two years in which to accomplish the great purpose of his mission. He had not, however, been idle on his route from Khartoum to Gondokoro, as by various means he had managed to inspire the slavehunters with a wholesome fear of himself, and had liberated several cargoes of slaves, to the great astonishment of the poor wretches themselves.

Sir Samuel found a great change in the river since his previous visit. The old channel was choked with sand-banks, new islands had been formed in many places, and it was impossible for the vessels to approach the old landing-place. The country around had, moreover, been swept of villages and inhabitants, who had been driven for refuge on the numerous low islands of the river. All that remained of the old mission station of the Austrian missionaries was an avenue of large lemon-trees. Sir Samuel landed a little below the site of Gondokoro, and lost no time in making himself and his companions as comfortable as circumstances would permit, forming a large encampment, and instituting an extensive system of cultivation. Indeed, wherever he went he attempted to instil a love of agriculture among the natives, as he did among his own people, giving away large quantities of seeds, accompanying the gifts with instruction as to the enormous benefits to be derived from cultivation. But his troubles multiplied upon him. He found the Baris, whose tribes occupy most of the district around his station, while professing the greatest friendliness, utterly hostile to the objects of the expedition; their minds had been

poisoned against him by the machinations of the demagogical Abou Saood, the representative of the great trading firm of Agâd & Co. of Khartoum, who had obtained from the Governor-General of Soudan a monopoly of the trade of all the Upper Nile district, extending over an area of 90,000 square miles. The great majority of his own officers and men, moreover, he found to be hostile to the purpose of the expedition, some of them being even secretly in league with the slave-traders. It was only by the exercise of rigid discipline and almost superhuman patience that between the hostile and treacherous tribes around and the "foes of his own house," the whole expedition did not fall to pieces. He was at last compelled in self-defence to fight the native tribes, and one

cannot but be struck with admiration at the skill with which he, with a handful of men—and the "Forty Thieves" were the only soldiers he could really depend upon—managed to keep his myriad enemies at bay. Happily he did ultimately succeed in convincing the natives that his intentions were earnest and disinterested, and before his return north he did succeed in thwarting the machinations of his great enemy Abou Saood, and clearing the country for many miles around his route of the slave-hunting brigands.

In January 1872 Sir Samuel started southwards with a small force of only about 200 officers and men; for the 1,200 with which he arrived at Gondokoro had by sickness, death, and desertion dwindled down to 500, 300 of



Arrival at the Steppage—The *Baleniceps rex*.

whom he had to leave behind him to garrison Gondokoro. Amid incredible difficulties, the small force reached Fatiko in the beginning of February. Fatiko is on the third parallel N., about seventy miles east of the head of the Albert N'yanza. After a short stay here, Sir Samuel, leaving half of his men behind, marched southwards to Unyoro, the capital of which, Masindi, he reached after disheartening delays and treacheries and equivocations on the part of the native chiefs, on April 25, 1872. The king of the district was Kabba Réga, a son of Baker's wily old friend Kamrasi. He turned out to be a treacherous, greedy, drunken, utterly irreclaimable "young cub," who under the influence of Abou Saood did his best to crumple up the small party which had entrusted themselves to his mercy. Sir Samuel at this, the southern

limit of his journey, did his best to plant the seeds of civilisation and a healthy commerce, but we fear succeeded in making little impression on the besotted Kabba Réga, who in the end, we are glad to find, was beaten by his well-intentioned brother Rionga, with the assistance of Sir Samuel. Here the latter endeavoured to obtain news of and to communicate with Livingstone by means of emissaries from M'Tese's country and other districts to the southward; and here he obtained reports which tended to confirm his conjecture that the Albert N'yanza extends south to a great distance, and communicates with Tanganyika. Sir Samuel, in his map, has filled in many names of tribes between the two N'yanzas, and we hope that the result of his expedition will be the more thorough exploration of this interesting district.

At last the determined and cowardly hostility of Kabba Réga and the thousands at his command became so unmistakable and dangerous, that after exercising astonishing forbearance and withstanding bravely several attempts at destruction, the handful of men, having set fire to all their property and their pretty little station, started on their march back to Foweera, the headquarters of Rionga, on June 14, 1872. This march of about fifty miles, we are sure, is unparalleled in history. It was mostly through thick grass reaching far above the head, through a continuous ambuscade of thousands of savage enemies, who kept up an almost continuous shower of spears within a few yards on each side of the short line of weak, hungry, but courageous men, who, notwithstanding, managed to reach Foweera with comparatively little loss. The brave Lady Baker performed most of the journey on foot, and Sir Samuel in the end pays a just tribute to his noble wife, who in many ways showed herself the ever-watchful good genius of the expedition.

We have only space to say further that Gondokoro was reached on April 1, 1873, when Sir Samuel found that his Englishmen had built a beautiful little steamer, and that the engineer, Edwin Higginbotham, was dead. Arrangements having been made to maintain Gondokoro as a station, Sir Samuel started homeward in the new steamer *Khedive* on the 25th of May, and after a swift and easy passage, reached Khartoum on June 29 and Cairo on August 24. Here the Khedive received Sir Samuel and his companions with well-merited honours, although we regret to say that he seems to have been powerless to act with the uncompromising decisiveness necessary to complete what Sir Samuel had so well begun. The latter had rid nearly the whole of the district through which the expedition journeyed, of the iniquitous slave-hunters, and justly expected that an end would have been put to the wickedness of the inhuman Abou Saoud. The final sentence of the narrative is almost crushing:—"After my departure from Egypt, Abou Saoud was released and was appointed assistant to my successor." We can only hope that this may not turn out so disastrous as it seems, but that Colonel Gordon may succeed, in spite of this suspicious companionship, in completing the work which it cost Sir Samuel and his party so much trouble to initiate.

One shuts the book with but a low idea of the natures whom the courageous Englishman tried to benefit; it would seem as if they had no single characteristically human quality which could be appealed to and used as a basis on which to rear the virtues of civilisation; and one is very much inclined to believe with Sir Samuel that some modification of the method which he found so successful in training the "Forty Thieves" might be more likely to succeed in raising these Africans from their slough than any appeal to their moral natures.

#### LETTERS TO THE EDITOR

[The Editor does not hold himself responsible for opinions expressed by his correspondents. Neither can he undertake to return, or to correspond with the writers of, rejected manuscripts. No notice is taken of anonymous communications.]

##### Endowment of Research

In the article on "Endowment of Research," in NATURE, vol. xi. p. 2, the following passage occurs:—

"It does not appear from the Report of the Commission that the Cambridge Colleges have yet taken any steps to appropriate definitely any portion of their endowments to the encouragement of scientific research; but it is a matter of common notoriety that at the October election to Fellowships at Trinity College, a candidate was successful whose chief qualification was that he had already accomplished good original work in embryological investigation."

Although it may not appear in the Report, it is nevertheless the fact, that in December 1872 the Master and Fellows of Trinity adopted a revised set of statutes, wherein are distinct provisions for the endowment of research, very like those commended in the case of New College, Oxford. The Privy Council has, however, deferred since January 1873 the consideration of these statutes, until the late Commission should have reported. This delay seems now all the more vexatious and unjustifiable, inasmuch as it appears from the Appendix to the Report, that changes of statutes were proposed at Oriet and New Colleges five months after the date of our proposal, and that these changes were ratified by the Privy Council within a few months in the ordinary manner.

If in the future the Government should desire to make any changes in this direction in the constitutions of the Colleges, it should be remembered to the credit of this College that two years ago a complete scheme was offered which made liberal provision for the endowment of research. It is due to external authority alone, that in the meanwhile vested interests have accrued, far heavier than any which would have arisen under the proposed statutes, and that nearly one-third of the University has been prevented from enjoying during the interval, statutes in accordance with the prevailing opinion inside, and certainly, as to scientific research, meeting with the approval of the outside world.

GEORGE DARWIN

Trinity College, Cambridge, Nov. 8

#### The University of London

In justice to the graduates of the University of London and to the Annual Committee of Convocation, I trust you will allow me to offer a few remarks with respect to Prof. Foster's opening address delivered at University College and published in your columns, vol. x. pp. 506 and 525.

Prof. Foster very justly complains that in the present regulations for the Matriculation Natural Philosophy Examination there is not "a title of internal evidence to show that they were drawn up in the present century," that there is a want of connection between the subjects required from candidates, and that the freedom of teachers in the instruction of their pupils is seriously interfered with, by the necessity of adapting lectures to the requirements of the examination.

None have shown themselves more sensible of the justice of these views than the graduates of the University; and, in a report which was drawn up by a sub-committee and adopted by Convocation, with reference to certain proposed modifications of the matriculation, the attention of the Senate was respectfully called to this portion of the examination. That report states:—"Your committee are strongly of opinion that no revision of the matriculation examination would be satisfactory which did not effect some improvement in that part of it which relates to Natural Philosophy. In proposing the following alterations, their objects have been to adapt this examination to the courses of lectures and to the most approved text-books on Physics."

It will be seen from this extract that Convocation was desirous that the examination should be brought into harmony with the best methods of instruction, and that the greatest possible freedom should be left to teachers. It was further suggested that the subjects of examination should include Mechanics, Hydrostatics, Heat, and Light, and that the first only of these subjects should be compulsory.

In the new regulations issued by the Senate, which will come into operation in June 1875, some improvements in this examination have been effected. The antiquated syllabus of subjects has been retained, but the whole character of the examination has been modified. Heat has been introduced; and it has been resolved that in the Natural Philosophy paper double as many questions shall be set as are required to be answered, and that candidates shall be free to choose any of them up to the required number. This alteration will effect a great improvement on the old system, which encouraged superficial knowledge by requiring candidates to answer one question at least out of certain

groups into which they were divided. The independence of teachers will, by these new regulations, be greatly increased; for they will no longer be compelled to hurry as rapidly as possible over the elements of various branches of physics, but will be free to teach certain portions of the subject with greater thoroughness, and will secure at the same time for their pupils a better chance of passing. Thus, supposing the questions to be equally apportioned, a candidate fairly acquainted with the elements of mechanics only would have no difficulty in succeeding.

The examinations for the Science degree are at present under the consideration of the Senate, and we may hope, therefore, that before long many of Prof. Foster's grounds of complaint will have been removed.

London, Nov. 9

PHILIP MAGNUS

### Gresham Lectures

IN NATURE, vol. xi. p. 2, appeared a very just and interesting article on the Gresham Lectures. I wish to endorse the opinion therein expressed of the misapplication of that institution.

Last Friday evening, at twenty minutes past seven, I entered Gresham College from curiosity. The two superb beehives to whom you allude were seated in the hall in all the glory of official gold lace. I walked into the lecture theatre, which to my surprise was more than half filled. A jerky lecturer in scarlet silk M.D. robes was unfolding the mysteries of sound. He was explaining that sound consisted of vibrations *like those of light*. He said that the lowest note appreciable to human ears was produced by 16, the highest by 24,000 vibrations per second. Prompted by his assistant (in whom I recognised the professor of chemistry at one of our metropolitan hospitals, and a talented lecturer), he said the velocity of sound was 1,125 feet per second, but did not allude to the variations in the same medium under different conditions of temperature and pressure. Light, he said, travelled 135,000 miles per second. He probably mistook an 8 for a 3 in the book from which he obtained his information. The velocity of sound in water, he said, had been determined by an English gentleman, who fixed a bell in a boat at one side of the Lake of Geneva and stayed on the other side himself; then he set the bell ringing by electricity, and plunged his head under the water at the same instant! This lucid explanation was received with all the seriousness with which it was delivered. He proceeded to explain the human voice, which he said resembled the harmonium; and he showed what he meant by the harmonium, namely, a small *harmonica*, or instrument in which plates of glass suspended on tapes are struck with a hammer consisting of a piece of cork on a whalebone. This information was also received with self-satisfied gullibility. Choking with indignation, I left the building, never having heard in all my life, either in sermon or lecture, so many false statements publicly uttered in the space of half an hour.

I am no physicist myself, but the fact that I have heard such men as Tyndall, and seen such experimenters as Frankland and Guthrie, probably accounts for my non-appreciation of the Gresham lecturer, who I understand is a classical scholar—*cela s'explique*.

MAURICE LICHTENSTEIN

Clyde Wharf Sugar Refinery, Nov. 8

### Insects and Colour in Flowers

THE true Darwinian answer to my letter in NATURE, vol. x. p. 503, has been fairly given by Mr. Boulger and Mr. Comber (vol. x. p. 520); but if that answer had appeared to me to be sufficient, the letter would not have been written.

Mr. Boulger correctly attributes to me the opinion that the development of beauty is an "object in nature." He thinks it a fallacious opinion: so I suppose does Mr. Darwin. I hold that opinion advisedly, however, and believe that the rejection of it is a constant source of error in Mr. Darwin's books, for which otherwise I have the profoundest respect and admiration.

I do not dispute that colour may be attractive to insects, or that the reproduction of plants may be assisted by it; but I reject the doctrine that the colour would have no *raison d'être* if insects were exterminated, and I believe that Mr. Darwin's theories upon this point are not sufficient to explain his own facts, or such other facts as are revealed by Mr. Comber's curious researches into the dispersion of coloured flowers.

I do not see any reason to doubt that if all flowering plants had been propagated by buds and stolons only, as some plants

practically are, the world at this epoch would still have known the beauty of flowers, although probably with less variety of form and colour. It is part of the natural development of the wave of life, as sure to be produced when the total conditions are ripe for it, as leaves in the spring, or as lycopods in the coal-age and conifers in the oolite.

The law of natural selection expresses truly enough the interaction of forces in the great heaving life-sea, but the forces are not increased or diminished by it, only modified in their lines of motion, the course made clear for one and obstructed for another: here a union of similars, and there a neutralisation of opposites; while each works out a destiny of its own as an individual wave, and shares the common destiny of some larger wave of which it is a constituent part.

What insects do in relation to the colour of flowers is to modify the conditions, so that the force, which has already begun to show its tendency to develop colour, may get freer play, and in each generation approach nearer to its climax.

The many instances in which colour is developed independently of insects seem to me to show quite conclusively that the colour-producing force which exists in the plant will break through all obstructions whenever the opportunity is presented. Sometimes increased richness of soil will furnish the necessary condition; sometimes a higher temperature; sometimes cross-fertilisation; sometimes the care and selection of man.

This law holds good throughout the organic world, and accounts for colour wherever it is found. The Darwinian doctrine of mere utilitarianism is driven to the strangest devices in its attempts to do the same thing.

Mr. Boulger speaks of the development of corolla at the expense of stamens as a "degradation of organs," and regards it in the light of a disease. Many botanists would agree with him, no doubt. But where is the proof of this? Is a plant produced for the mere purpose of *re-production*? Is that even its highest purpose? Whatever *beauty* may be, the reproductive process is assuredly a mean, and not an end.

There is some ground for the hypothesis that the flower of a plant represents its nervous centre, that it is the analogue, perhaps even the homologue, of the brain and countenance of the higher animals. In vegetables the reproductive organs are associated with this nervous centre. But they are not so placed in animals, and if they had been otherwise arranged in vegetables the blossom might still have been the crowning beauty of the plant.

I do not admit that the metamorphosis of stamens into corolla is a degradation at all. I am no sure whether the production of perfectly double and perfectly barren flowers ought not to be regarded as the final goal of every species of plant—the point at which reproduction becomes no longer necessary, because the life-wave of that species has reached its climax and needs no further to be carried forward from generation to generation.

Finally, the point at issue amounts to this: Is colour in flowers a mere expedient for getting them cross-fertilised? or is it a natural and necessary phase in the development of plant-life, which serves also the secondary purpose of securing the advantage of cross-fertilisation; as the brain of man, which is primarily the great organ of thought and sentiment, serves also the secondary purpose of selecting wholesome food?

I hold to the latter view, which includes and accounts for all that the other does, and much besides.

F. T. MOTT

Leicester

LORD RAYLEIGH, in NATURE, vol. xl. p. 6, questions whether the colour-sensations of insects are analogous to ours. As tending to illustrate this subject, let me quote the following paragraph from the scientific column of the *Illustrated News* of April 2, 1870, p. 362:—

"The spectrum of the light of the firefly has been examined, and it is found to be perfectly continuous, without traces of lines either bright or dark. It extends from about the line C in the scarlet to F in the blue, and is composed of rays which act powerfully on the eye, but produce little thermal or actinic effect. In other words, the fly, in producing its light, wastes but little of its power."

This, it is true, tells nothing as to the colour-sensations of the insect, but it appears to show that the same rays are luminous to its eyes which are luminous to ours.

JOSEPH JOHN MURPHY

Old Forge, Danmurry, Co. Antrim, Nov. 8

## Locomotion of Medusidæ

I DO not think that the following remarkable observation has hitherto been made—or at least recorded—by anyone; but as I am at present deprived of access to books, it is possible that I may be mistaken upon this point. It will be observed that it tends experimentally to confirm the opinion of Agassiz, M'Crady, and Fritz Müller, as to the presence of ganglionic centres in the situations they describe.

*Slabberia conica* is, as its specific name implies, a medusid of a conical form, and its size is about that of a fully-developed acorn. Its polypite, which is of unusual proportional length, is highly contractile; and its swimming-bell (*nectocalyx*) supports four short slender tentacles, which are likewise highly contractile. These tentacles take their respective origins from four minute vesicular-like bodies (*marginal vesicles*), which are so situated in the margin of the nectocalyx as to mark off this circular margin into four exact quadrants. If any one of these vesicular-like bodies be excised, immediate and total paralysis ensues in the segment of the cone in which it is situated; i.e., a fourth part of the entire animal ceases to contract. If two adjacent vesicles are excised, one half of the entire animal becomes paralysed, the loss of motion being quite as decided, and the area of its occurrence quite as well defined, as in the case of hemi-section of the spinal cord. If three of these bodies are removed, cross paralysis results; if three of these bodies are cut out, only one quarter of the cone continues to contract; and lastly, if they are all taken away, every vestige of contractility immediately disappears, not only in the nectocalyx, but also in the polypite. Now, as the bodies in question are not so large as are the dots over the letter "i" in this printed description, the extreme localisation of stimulating influence thus shown to exist cannot but be deemed a highly remarkable fact, more especially as no amount of mechanical or chemical irritation will cause the slightest contraction in any part of the animal subsequent to the removal of these four almost microscopic points; while, contrariwise, so long as any portion of tissue (no matter how small) is left united to one of these points, it will continue its rhythmical movements for an indefinite period of time. Thus, for example, when a section is made through the equator of the animal, while the upper half at once ceases to move, the lower half—now converted into an opening—continues its contractile motions for days with unimpaired energy, notwithstanding the thus mutilated organism is, of course, unable to progress.

It is well known that when the entire margin of the nectocalyx of a medusid is removed, the contractility of the remaining portion is destroyed. This fact is usually explained by supposing that the severance of all the contractile fibres produces what may be called mechanical paralysis, just as a man could not move his arm if all its muscles were divided. Experiments I have made on other species of *Medusidæ* have led me to doubt the truth of this explanation—at all events as the whole explanation; but it is unnecessary to detail these at present. The instance above given is enough to show that in the case of this species, at any rate, such an explanation is clearly insufficient, and my object in now writing is to request that if any of your readers are acquainted with observations (whether published or not) similar to those described, they should kindly let me know, either through your columns, or by writing to Gonville and Caius College, Cambridge.

GEORGE J. ROMANES

Dunskaitli, Ross-shire

## Suicide of a Scorpion

I SHALL feel obliged if you will record in NATURE a fact with reference to the common Black Scorpion of Southern India, which was observed by me some years ago in Madras.

One morning a servant brought to me a very large specimen of this scorpion, which, having stayed out too long in its nocturnal rambles, had apparently got bewildered at daybreak, and been unable to find its way home. To keep it safe, the creature was at once put into a glazed entomological case. Having a few leisure minutes in the course of the forenoon, I thought I would see how my prisoner was getting on, and to have a better view of it the case was placed in a window, in the rays of a hot sun. The light and heat seemed to irritate it very much, and this recalled to my mind a story which I had read somewhere, that a scorpion, on being surrounded with fire, had committed suicide. I hesitated about subjecting my *pet* to such a terrible ordeal, but taking a common botanical lens, I focused the rays of the sun on its back. The moment this was done it began to run hurriedly

about the case, hissing and *spitting* in a very fierce way. This experiment was repeated some four or five times with like results, but on trying it once again, the scorpion turned up its tail and plunged the sting, quick as lightning, into its own back. The infliction of the wound was followed by a sudden escape of fluid, and a friend standing by me called out, "See, it has stung itself; it is dead;" and sure enough in less than half a minute life was quite extinct. I have written this brief notice to show (1) That animals may commit suicide; (2) That the poison of certain animals may be destructive to themselves.

Bridge of Allan, N.B., Oct. 23

G. BIDIE

## THE AMÚ EXPEDITION

WE give some extracts from a letter relating to the hydraulics of the Amú, sent us by an English engineer who was with the expedition; the letter is dated "Nukus, at the head of Amú delta, Sept. 10, 1874:—"

The expedition only arrived in the delta at the end of June; it is impossible, therefore, to say at what date the first spring flood of the river takes place, but probably between the 1st and 15th of May. The level of the river on June 23 was what may be called a low-level full river: it fell about twelve centimetres till June 29, and then rose rapidly till July 11, when it was 145 centimetres above the level of June 23. It then fell fifty centimetres up to July 17, and rose again to nearly the previous height on Aug. 4. Since that date the river has fallen steadily, and is to-day some fifty centimetres below the level of June 23. I judge the heights of July 11 and Aug. 4 to be the extreme flood level of the Amú. At that flood level, the discharge at Toyu-boyin, "The Camel's Neck," 160 miles above the head of the delta, cannot be far short of 140,000 cubic feet per second. It is difficult to say what the low-water discharge is, but I should think it is at least 70,000 cubic feet per second.\* On Aug. 25, by a rough observation, it was 110,000 cubic feet a second, the river then being 25 centimetres above the level of June 23. At Toyu-boyin the river has cut its way through a bed of shelly limestone of the age of the chalk. The limestone is very compact and hard, full of small shells, turritella and bivalves. Here the river is 1,000 ft. broad. The height to which the limestone bed has been tilted is about 25 ft. The river expands in breadth immediately afterwards to 2,000 ft. or more, for about five miles; it then begins to contract again, having on its left a high bank of hard clay passing almost into an argillaceous schist. This high bank extends for above five miles, and ends in an eminence of 50 or 60 ft. in height, crowned with sand. From Toyu-boyin downwards on the right bank, are ridges (of clay, I imagine) crowned with sand: no cultivation on that bank, but opposite and downwards from Toyu-boyin irrigation canals are taken off, excepting where the high clay bank occurs. At the eminence spoken of the river immediately widens to 5,000 ft. or so; this is caused by the first large irrigation canal Polwán. As these canals have a *great effect* on the river all the way down to the delta, I will here try and explain my theory on the subject. As the Amú runs in a soft soil from the south to north nearly in the direction of the meridian, I imagine what the Russians call the law of Bär (from his observations on the Volga) comes into action. The stream has therefore the tendency to run along the right bank, and, as a matter of fact, the deep-water channel is there found. If, then, an irrigation canal be opened on the left bank, the stream is disturbed and a subsidiary deep channel is formed towards the head of the canal (Fig. 1). The head of the canal is only open during flood, say half the year. When it is shut, the river will run as in Fig. 2: silt will be found at the shaded parts. The river by Bär's law will edge away to the right and become broader, and if by this process is continued

\* Perhaps this is too high—I cannot make out from Wood's "Oxius" more than 45,000 cubic feet or so per second for winter discharge.

year after year, the river bed is filled with islands. The deep-water channel is generally found on the right bank, but of course circumstances occasionally cause it to pass between two islands. Figs. 3 and 4 are two rough cross sections of the river.

In the latter case the river has a breadth between its banks, sometimes from 5,000 ft. to 8,000 ft., especially opposite New Urgens and Shah Abbas Wali. The state of matters described has the effect of turning the river into a series of large pools, connected by short portions of stream; and this again probably has the effect of causing irregular floods in the river; for as the quantity of water decreases and the velocity also decreases, silt is deposited and a *quasi* natural dam (Fig. 5) is formed, until

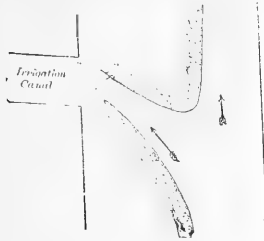

FIG. 1.

such time as sufficient water has been dammed up to burst through and sweep away this silt dam. Of the 140,000 cubic feet of flood-discharge, it is probable that the irrigation canals take, at most, 30,000 cubic feet per second; so that at Khodjeili, the head of the delta, say of a high flood, 110,000 cubic feet arrive. Of this quantity, 30,000 cubic feet flow by Kuwar Jerma, 30,000 by Chertambye, 20,000 by the next two branches, and the balance by Taldik. But of the whole quantity not more probably than 60,000 cubic feet at the most reaches Aral. The remainder floods the delta and Abougir.\* Of the winter discharge, I should suppose not more than 40,000 cubic feet passes Khodjeili. I cannot account for the difference, unless it is ponded up in the upper reaches of the river. The irrigation canals are closed in



FIG. 4.—Ordinary Section, with irrigation canals.

changed the course of the river. M. Barbot de Morny has recently examined the Usturt plateau, and, as far as I can gather, confidently asserts that Usturt has never been upheaved at all, but that it formerly formed an island in the united Caspian and Aral. As regards the eminences in the delta, and the ridge of Bish'yabye, which is a continuation of Shaikjaili to the north, along the right bank of the river, he also says that there is not the least trace of any geological action having taken place in recent or historic times, so that it seems probable that here is an additional laurel for Lyell, plucked from the brow of Humboldt. If, therefore, the river will flow naturally to the Caspian, what Russia must do is to take, say, two-thirds of the Amú water for a canal to the Caspian,

\* And is used in irrigation near Kungrat. In my opinion the level of the Aral is rising, but other's say not.

winter. About 12,000 pass along Kuwar Jerma, and the same quantity along Chertambye. The rest passes mostly along Taldik; not more than 1,000 cubic feet a second passes along Ulkun Darya from Kungrat. In winter there is ice to a thickness of 15" on the



FIG. 2.

river, but certainly not everywhere; there is a thaw generally about the end of January, then a second severe winter in February. In the sketch (Fig. 6), 1, 2, 3, 4 are old branches of the river which flowed into the Caspian\* at different times; 5 is an old bed which met a branch from Syr, on the east of Aral. These combined waters probably formed the delta Herodotus speaks of; but I am going to take a look at this during my ride across the steppe to Fort Perofsky. The river, I believe,

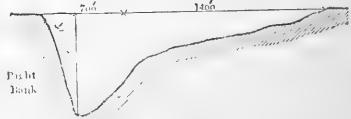

FIG. 3.—Ordinary Section—no irrigation canals.

will naturally flow to the Caspian if it is allowed to do so; but the questions concerned are too large to be more than alluded to here. The Russian idea, following Humboldt, is that the whole country east of the Caspian has been upheaved, and that this has



FIG. 5.

running west from Toyu-boyin, for irrigating the country as well as for forming a line of water communication. The remaining third she must project along the old bed No. 5, or somewhere in that direction, to meet a branch from Perofsky on the Syr. The water for this branch from Perofsky must be obtained by reclaiming the swampy district of Karaouzak. This swamp was formed by the river breaking into an irrigation canal taken from the right bank. The water feeding the swamp is that which formerly fed the Djani Darya flowing south-west from Perofsky towards the point where I suppose the old delta mentioned by Herodotus to have been.

I can tell you nothing about Shaikjaili, as I could

\* There is an old bed running due west to the Caspian from a point a little north of Tchardjuj. A Russian officer, who spent many years between the Caspian and that place, is my informant. The river must have flowed in it before Arrian's day.





Edward Hermon, Esq., M.P. for Preston .....	£	1	0
Capt. J. Herschel, F.R.S., &c. ....	1	1	0
The Parish of Hoole .....	5	5	0
The Right Hon. Lord Houghton, F.R.S., &c. ....	1	1	0
William Huggins, Esq., D.C.L., LL.D., F.R.S., Foreign Secretary of the Royal Astronomical Society	1	1	0
Sir J. Kay-Shuttleworth, Bart. ....	1	1	0
William Lassell, Esq., F.R.S., &c. ....	1	1	0
Lord Lindsay, M.P., &c. ....	1	1	0
J. Norman Lockyer, Esq., F.R.S., &c. ....	1	1	0
The Right Rev. the Bishop of Manchester .....	1	1	0
Mrs. Charles Orme .....	1	1	0
Mrs. G. M. Patmore .....	1	1	0
William Pollard, Esq. ....	1	1	0
The Rev. Charles Prichard, M.A., F.R.S., Savilian Professor of Astronomy in the University of Oxford	1	1	0
Richard A. Proctor, Esq., B.A., &c. &c. ....	1	1	0
A. Cowper Ranyard, Esq., M.A., Secretary to the Royal Astronomical Society .....	1	1	0
The Earl of Rosse, F.R.S., &c. &c. ....	1	1	0
Henry J. S. Smith, Esq., M.A., F.R.S., Savilian Professor of Geometry in the University of Oxford	1	1	0
F. Styles, Esq. ....	1	1	0

General Treasurer—Prof. ADAMS, the Observatory, Cambridge.

The Rev. R. Brickel, the Rectory, Hoole, Preston, Lancashire; Prof. Grant, the Observatory, Glasgow; Mrs. G. M. Patmore, 81, Avenue Road, N.W.; and A. Cowper Ranyard, Esq., 25, Old Square, Lincoln's Inn, W.C., have kindly promised to receive and acknowledge subscriptions.

## FERTILISATION OF FLOWERS BY INSECTS\* VII.

*Butterflies the most frequent visitors of Alpine flowers.*

IN the following article I wish to recommend for further inquiry a subject of peculiar interest which, in the environs of the Orler, in Tyrol, forced itself on my attention last summer, but which, during my short stay in the Alps (8—25 July), I had not time to investigate so thoroughly as it deserves. Whilst occupied, along with my son, in observing the Alpine flowers and their fertilisation by insects, we were struck with the very small number of Apidæ met with in higher Alpine (subnivall) localities, and with the predominant part which butterflies play in this region in relation to the fertilisation of flowers. In the environs of "Piz Umbrail" and "Quarta Cantoniera," 3,000—2,400 metres above the sea-level, we observed only four humble bees, and not a single individual of any other genus of Apidæ during a sojourn of five days, and in spite of very fine weather, whilst numerous Coleoptera (Dasytes, Anthobium, Anthophagus), many Diptera (especially Muscidæ and Syrphidæ), and very numerous specimens of some species of Lepidoptera were found in the flowers of this region.† Between 2,400 and 2,100 metres (descending towards Bormio and in the environs of Franzenshöf and Trafoi) the number and variety of Apidæ, other Hymenoptera, Coleoptera, and Diptera proved to be much greater; but, at the same time, the number and variety of Lepidoptera increased to such a degree that this order of insects was in unmistakable preponderance also in this region.‡ In the plain, near Lippstadt, on the contrary, and in the lower mountainous region of Sauerland, Thuringia, and Fichtelgebirge, Diptera, but more especially Apidæ, are the most frequent visitors of flowers,

although in the latter region a considerable increase in the proportion of Lepidoptera may be remarked.

Consulting our highest authority on the geographical distribution of butterflies in Germany and Switzerland, Dr. Speyer, of Rhoden, I heard that the fact alluded to would be in direct opposition to the general distribution of the species of Lepidoptera in altitude, the number continually decreasing from the lower mountainous to the higher Alpine (subnivall) region; only the plain, as it seems, being somewhat poorer. This contradiction, however, may be, and, as I am convinced, from my observations, is, only an apparent one; for, notwithstanding the smaller number of species, the absolute frequency of Lepidopterous individuals, and perhaps also of species, is considerably greater in favourable Alpine localities than in equally large tracts of the lower mountains and of the plain, firstly in consequence of the smaller number of Alpine species distributed over a very restricted area; and secondly, because many of these species are represented in their restricted localities by a surprising number of individuals. Dr. Speyer himself writes me: "I have also myself been frequently struck with the great number, not only of individuals, but also of species, met with in favourable Alpine localities." Moreover, the relative frequency of butterflies, which alone is concerned in estimating their importance in the fertilisation of flowers, seems to be still greater than their absolute frequency in the higher Alpine (subnivall) region; insects of other orders, with exception of the Diptera, apparently decreasing in a still larger ratio towards the snow-line. In order to appreciate adequately the differences of frequency alluded to and the share taken by butterflies in fertilising flowers in different regions, it would be necessary to ascertain the exact number of individuals of Lepidoptera and of other insects that visit certain flowers of the different regions in a given time. Unfortunately I have neglected such observations, and can only give some statistical data as to the number of species of Lepidoptera and other insects observed by myself to visit flowers in different regions. These data can afford but an approximate idea of the above differences, but they will, I hope, sufficiently show that these differences are by no means a product of my imagination, but a matter of fact, and that in Alpine regions Lepidoptera are really of considerably greater importance in relation to the fertilisation of flowers than in the plains.

There are some few species of flowers which I have had the opportunity of observing as to their visitors both in the plain or in the lower mountainous and in the Alpine region; these, of course, will be the most useful for comparison. For the sake of a more easy survey of the statistical notes I shall make use of the following abbreviations: *a* = in the plain, near Lippstadt; *b* = in the lower mountainous region of Sauerland, Thuringia, Fichtelgebirge; *c* = in the Alpine region, near Trafoi, Franzenshöf, Quarta Cantoniera; *Ap.* = Apidæ; *Lep.* = Lepidoptera; *O.I.* = other insects.

The following is a list of the visitors to different plants, so far as I have observed.

### 1. *Helianthemum vulgare* :—

*a.* Ap. 5, Lep. 1, O.I. 16 species; Ap. 23, Lep.\* 5, O.I. 72 per cent.  
*b.* " 3, " 7, " 3 " " 9, " 64, " 27 "

### 2. *Lotus corniculatus* :—

*a.* Ap. 19, Lep. 5, O.I. 2 species; Ap. 73, Lep. 19, O.I. 8 per cent.  
*b.* " 17, " 7, " 2 " " 65, " 27, " 8 "

*c.* " 2, " 4, " 0 " " 33, " 66, " 0 "

### 3. *Prunella vulgaris* :—

*a.* Ap. 8, Lep. 4, O.I. 0 species; Ap. 66, Lep. 33, O.I. 0 per cent.

*b.* " 4, " 2, " 0 " " 66, " 33, " 0 "

*c.* " 2, " 4, " 1 " " 17, " 67, " 17 "

\* It should be noticed that as the flowers of *Helianthemum vulgare* do not secrete honey, Lepidoptera must either obtain a little of the juices of the flowers by boring, or are altogether deceived.

† In the Alpine region my observations have been made on the *var. grandiflorum*.

\* Continued from vol. x. p. 130.

† Rhopalocera: *Pieris callidice* Esp., *Lycæna orbitulus* Prunn., *L. semiargus* Rott., *Melitæa merope* Prunn., *M. farthenia* Bkh. var. *varia* M.D., *Argynnis palea* W.V., *Erebia gylarvus* Esp. Geometræ: *Fodas a'bonia* Scop., *Pygmaea lutea* Thbg., *Crambina*: *Hercynus schrankiana* Hüb. (*Holopleris* H.), *H. phrygialis* H., *H. rufipetralis* H., *Crambus lactiflorus* H.—according to Dr. Speyer's determination.

‡ I found here Rhopalocera 33, Sphingidæ 4, Bombyces 5, Noctuæ 3, Geometræ 3, Crambina 6, Tinea 2, Pierophorina 1, altogether 57 species of Lepidoptera visiting flowers.

4. *Thymus serpyllum* :—

a. Ap. 7, Lep. 5, O.I. 17 species; Ap. 24, Lep. 17, O.I. 58 per cent.  
 b. " 5, " 17, " 23 " " 11, " 35, " 51 "  
 c. " 2, " 17, " 0 " " 10, " 89, " 0 "

5. *Taraxacum officinale* :—

a. Ap. 58, Lep. 7, O.I. 28 species; Ap. 62, Lep. 7, O.I. 30 per cent.  
 b. " 0, " 2, " 1 " " " 0, " 66, " 33 "

6. *Valeriana officinalis* :—

a. Ap. 3, Lep. 0, O.I. 10 species; Ap. 14, Lep. 0, O.I. 86 per cent.  
 b. " 3, " 2, " 2 " " " 43, " 28, " 28 "

All these species show evidently the predominant part which Lepidoptera play as visitors of flowers in the Alpine region. The same result is arrived at by comparing sister-species or sister-genera of flowers, provided with nearly the same contrivances and growing one or some of them in the Alpine region, another or some others in the lower mountainous region, or in the plain.

7. *Geranium pratense* (a, b), and *ylvaticum* (c) :—

a. Ap. 9, Lep. 0, O.I. 1 species; Ap. 50, Lep. 0, O.I. 10 per cent.  
 b. " 13, " 1, " 3 " " 76, " 6, " 18 "  
 c. " 3, " 8, " 3 " " 21, " 57, " 21 "

8. *Veronica chamaedrys* (a), and *saxatilis* (c) :—

a. Ap. 5, Lep. 1, O.I. 7 species; Ap. 38, Lep. 8, O.I. 54 per cent.  
 c. " 0, " 4, " 3 " " " 0, " 57, " 43 "

9. *Fasione montana* (a), and *Phyteuma nichelii* (c) :—

a. Ap. 47, Lep. 7, O.I. 47 species; Ap. 47, Lep. 7, O.I. 47 per cent.  
 c. " 7, " 13, " 4 " " 29, " 54, " 16 "

10. *Carduus crispus* (a), *acanthoides* (b), and *decoloratus* (c) :—

a. Ap. 9, Lep. 3, O.I. 3 species; Ap. 60, Lep. 20, O.I. 20 per cent.  
 b. " 32, " 5, " 9 " " 70, " 11, " 19 "  
 c. " 3, " 8, " 7 " " 21, " 49, " 37 "

11. *Chrysanthemum leucanthemum* (a), *corymbosum* (b), and *alpinum* (c) :—

a. Ap. 12, Lep. 8, O.I. 49 species; Ap. 17, Lep. 12, O.I. 71 per cent.  
 b. " 3, " 3, " 18 " " 125, " 123, " 75 "  
 c. " 0, " 4, " 5 " " 0, " 44, " 55 "

12. *Senecio Jacobaea* (a), *nemorensis* (b), *abrotanifolius*, *Doronicum* and *nebrodensis* (c) :—

a. Ap. 15, Lep. 2, O.I. 19 species; Ap. 42, Lep. 5, O.I. 53 per cent.  
 b. " 7, " 8, " 2 " " 41, " 47, " 12 "  
 c. " 1, " 20, " 14 " " 3, " 57, " 40 "

The predominant part played by Lepidoptera in the Alpine region would doubtless appear considerably less striking if the more southern or eastern districts of Germany had been compared with the Alps; for, according to Dr. Speyer,\* the number of species of Lepidoptera continually increases in Germany from the north southwards, and from the west eastwards, to such an extent that, for instance, the number of species of diurnal butterflies (Rhopalocera) amounts, near Hamburg, to 72, near Dantzig to 89, near Freiburg (Baden) to 100, and near Vienna to 130. Hence Lippstadt, in consequence of its north-west situation, ranges among the poorest localities of Germany with respect to butterflies; and the environs of Vienna would possibly have afforded nearly double the number of Lepidoptera as visitors of the above-named flowers. But if even in a and b of the above statistical notes the number of Lepidoptera be doubled, in all cases, with the sole exception of *Senecio nemorensis*, the Alpine region would retain a decided preponderance as regards the frequency of butterflies that visit flowers, and even *Senecio nemorensis* is not an exception to the general rule, as my observations on this species have not been made near Lippstadt, but in the "Waldstein," one of the summits of the "Fichtelgebirge."

Hence, though further observations may be necessary, I cannot doubt that the increasing proportion of Lepidoptera which visit flowers in the higher Alpine region will hold good, even after the most extensive and thorough examination of the whole of Germany. Some peculiarities of the Alpine flora to be discussed in my next article, will, I hope, confirm this opinion.

HERMANN MÜLLER

\* Die geographische Verbreitung der Schmetterlinge Deutschlands und der Schweiz. Von Dr. Adolph Speyer und August Speyer. Leipzig, 1858, p. 29.

## THE CHEMISTRY OF CREMATION

IN a paper recently published in a German periodical,\* on the chemical bearings of cremation, Prof. Mohr calls attention to a point which, so far as we know, has not yet been considered.

He remarks that, in the first place, it is necessary that the combustion of the body should be complete. Anything of the nature of distillation gives rise to the production of fetid oils, such as were produced when in early times dead horses were distilled for the manufacture of sal-ammoniac. Such a revolting process is surely not compensated by the small commercial value of the products obtained. To effect complete combustion we must have a temperature such that the destruction is final, nothing remaining but carbonic acid, water, nitrogen, and ash; for which purpose a complicated apparatus consuming large quantities of fuel will be necessary. The gases produced can only be destroyed by being passed through red-hot tubes to which excess of atmospheric air can gain access.

On comparing the substances produced by such a total decomposition of the body with those produced in the ordinary course of subterranean decay, it will be seen that one compound is totally lost by burning—the ammonia which results from the decomposition of the nitrogenous tissues. This ammonia, escaping into the air or being washed into the soil, is ultimately assimilated by plants—goes to the formation of nitrogenous materials, and thus again becomes available for animals. In the ordinary course of nature a continuous circulation of ammonia between the animal and vegetable kingdoms is thus kept up: if we stop one source of supply of this substance, we destroy the equilibrium—we draw upon the ammonia capital of the globe, and in the course of time this loss cannot but react upon animal life, a smaller amount of which will then be possible. There is no compensating process going on in nature as is the case with the removal of atmospheric oxygen by breathing animals—we deduct from a finite quantity, and the descendants of present races will, in time to come, have to bear the sin of our shortsightedness, just as we have had to suffer through the shortsightedness of our ancestors, who destroyed ruthlessly vast tracts of forests, thereby incurring drought in some regions and causing destructive inundations in others.

Another loss of ammonia is entailed by civilisation in the use of gunpowder. Nitre results from the oxidation of ammonia, and is a source of nitrogenous compounds to plants, which again reduce the nitrogen to a form available for ammonia. The nitrogen liberated by the explosion of gunpowder adds to the immense capital of the atmosphere, but is no more available for the formation of plants. Every waste charge of powder fired represents a certain loss of life-sustaining material against which the economy of nature protests. The same is to be said of nitro-glycerine, gun-cotton, &c., which contain nitrogen introduced by the action of nitric acid.

Wood and coal are other illustrations of finite capital. Every pound of these substances burnt in waste—consumed, that is, without being made to do its equivalent of work—is a dead loss of force-producing material, for which our descendants will in the far-distant future have to suffer. The changes brought about by the cessation of one large supply of ammonia may be compared with geological changes which, though of extreme slowness, produce vast changes in the lapse of ages. R. M.

## A NEW MATERIAL FOR PAPER

THE grass known as Canada Rice (*Zizania aquatica*, Lili., *Hydrophyrum esculentum*, Link) is well known to American botanists as a cereal. Linnæus names it, as long ago as 1750, in his "Philosophia Botanica," under the

\* *Dahlem*, No 44

class of Cerealia; it is mentioned under that name by Lindley in his "Vegetable Kingdom;" and in the "Treasury of Botany" it is stated that "the large seeds yield a considerable amount of food to the wandering tribes of Indians, and feed immense flocks of wild swans and other aquatic birds. It grows well in Britain when it is once established, but it is liable to die away if not cared for." It is asserted, indeed, that many of the wandering tribes of native Indians depend on the harvest of Zizania, known by them as "Tuscarora," as their principal source of food during the winter; and that so palatable is the grain that people who, at the period when it is ripe, make their way into the region where it grows, never fail to bring home a sackful as a present to their friends.

It is not, however, as an article of food that we now call attention to the plant, but in consequence of its alleged value as a material for the manufacture of paper.\* If all that is stated respecting it is confirmed, it will be a formidable rival to Esparto in the manufacture of the various kinds of printing paper, yielding fully as much of the raw material, and possessing the great and peculiar merit of being comparatively free from silicates; it is claimed, indeed, that paper made from it is quite as strong and flexible as that made from rags. It is easily bleached, economical in respect of chemicals, pure in colour, and the paper presents a surface of perfect evenness remarkably free from specks and blemishes. The paper has the further merit of receiving a very clear impression from the printer's types. It would appear, indeed, to possess all the merits, without any of the defects, of Esparto.

The Zizania belongs to the tribe Oryzæ, closely resembling the rice-plant both in structure and habit, except that the flowers, instead of being perfect, are unisexual, but monœcious. The number of stamens in both plants is six. It is an aquatic plant, growing in swamps, ponds, and shallow streams, filling them up, during summer, with a dense annual growth. The average height is from 7 to 8 ft., but it not infrequently reaches 12 or 14 ft. The district in which it appears to flourish most abundantly is the Canadian territory, on the shores of Lakes Erie, St. Claire, and Ontario, from whence it can easily be transported to Montreal, and shipped to any European port. It is stated that there will be no difficulty in obtaining an annual supply of 100,000 tons; but that the chief obstacle to its conveyance to Europe is the great bulk it occupies, and the consequent heavy freight, which seems at present to act as an almost entire prohibition on its importation.

#### NOTES

PROFESSOR MASKELYNE has offered to give a short course of lectures on Crystallography to those members of the Chemical Society who may be desirous of studying this subject. It is proposed, if a sufficient number of members intimate their intention of attending, that the lectures be delivered on Mondays and Fridays, at 8.30 P.M. during the months of November, December, and January, commencing on the 23rd inst. Professor Maskelyne hopes it will be understood that gentlemen attending those lectures will be prepared to devote some of their leisure to working at the subject in the manner to be indicated by the lecturer. Crystallography cannot be studied without geometrical reasoning, but it will be Mr. Maskelyne's endeavour to treat his subject with as small an amount of mathematical detail as is consistent with its due development. The lectures will be open to anyone introduced by a Fellow of the Chemical Society. It is particularly requested that members intending to attend these lectures will communicate their intention, previously to the 20th inst., to Dr. Russell. We congratulate the Chemical Society in having initiated such a movement. We hope the lectures will be largely taken advantage of, and that other societies will soon follow this excellent example.

\* For the majority of the following particulars we are indebted to an article in the *Gardener's Chronicle*.

NEWS has been received from the *Challenger* up to Sept. 8, giving an account of the voyage between the Fiji Islands and Torres Strait. Occasional squalls were met with, and the usual sounding, dredging, and trawling operations were carried on. Shortly after leaving Api Island, New Hebrides, soundings were taken in 2,650 fathoms, giving a bottom temperature of 35.7, the same temperature being obtained at 1,300 fathoms. The same phenomenon occurred for some distance, leading to the conclusion that a valley exists at the place, surrounded by a ridge. Several new specimens of fish were found, and the naturalists explored Raine Island. From Cape York the ship proceeds through Torres Strait and Ararua (Sea, visiting Manilla and other places, and arriving at Hong Kong about the middle of the present month, where she will stay till the end of December. Letters should be addressed to Singapore till the mail of Jan. 22, 1875; then to Yokohama, Japan.

ON Tuesday evening the winter session of the Royal Geographical Society was opened by an address from the president, Sir H. C. Rawlinson, who reviewed the progress of discovery during the past year, and expressed a confident hope that a new polar expedition would be despatched under the auspices of her Majesty's Government in the course of the coming year. Lieut. Payer was present, and the secretary read his narrative of the Austrian Polar Expedition, the main details of which have appeared in NATURE. A letter was also read from Dr. Petermann, strongly urging upon her Majesty's Government the expediency of starting another polar expedition: this will be found in another column.

THE following, we learn from the *Times*, is the list of the new Council to be proposed for election at the anniversary meeting of the Royal Society on St. Andrew's Day, 30th inst.:—President, Joseph Dalton Hooker, C.B., M.D., D.C.L., LL.D.; treasurer, William Spottiswoode, M.A., LL.D.; secretaries, Prof. George Gabriel Stokes, M.A., D.C.L., LL.D., and Prof. Thomas Henry Huxley, LL.D.; foreign secretary, Prof. Alexander William Williamson, Ph. D.; other members of the Council—Prof. J. C. Adams, LL.D., the Duke of Devonshire, K.G., D.C.L.; John Evans, Pres. G.S., F.S.A.; Captain Frederick J. O. Evans, R.N., C.B.; Albert C. L. G. Günther, M.A., M.D.; Daniel Ijanbury, Treas. L. S.; Sir John Hawkshaw, M.L.C.E.; Joseph Norman Lockyer, F.R.A.S.; Robert Mallet, C.E., M.R.I.A.; Nevil Story Maskelyne, M.A.; C. Watkins Merrifield, Hon. Sec. I. N. A.; Prof. Edmund A. Parkes, M.D.; Right Hon. Lyon Playfair, C.B., LL.D.; Andrew Crombie Ramsay, LL.D.; Major-General Sir H. C. Rawlinson, K.C.B., and J. S. Burdon Sanderson, M.D.

THE Cambridge Board of Natural Sciences Studies have nominated Mr. F. M. Balfour, B.A., Fellow of Trinity College, and Mr. A. W. Marshall, Scholar of St. John's College, as students in the Zoological Station at Naples until the end of next summer.

THE Worshipful Company of Clothworkers have offered to the Board for Superintending Non-collegiate Students at Cambridge three exhibitions of the value of 50*l.* per annum each, to be awarded to non-collegiate students for proficiency in physical science, each exhibition to be tenable for three years, so that one will be available for competition annually. There will be an examination for one of these exhibitions on Thursday, January 14, 1875, in the Censor's Room, at 9 A.M. The exhibition will be open to all non-collegiate students who have already commenced residence, or those not in residence, provided they commence not later than Michaelmas Term 1875. Each candidate will have to satisfy the examiners in at least two of the following subjects:—Statics and dynamics, hydrostatics and pneumatics, heat; and may be examined in not more than two of the following:—Chemistry, botany, physical geography, including meteorology. Candidates

must send their names to the Rev. R. B. Somerset, Cambridge, on or before December 1, of whom further particulars may be obtained.

THERE will be an examination for Scholarships and Exhibitions at Christ's College, Cambridge, on April 6, 1875, and three following days, open to the competition of students who intend to commence residence in October 1875. Scholars will be selected for proficiency in one or more of the following subjects:—(1) Chemistry and chemical physics; (2) geology and mineralogy; (3) botany; (4) zoology, with comparative anatomy and comparative physiology. A candidate may select his own subjects, but will be required to show such knowledge of classics and mathematics as to afford reasonable expectation that he will pass the Previous Examination without difficulty. Every candidate must send his name to the tutor (Mr. John Peile, M.A.) on or before March 30, 1875, and if a candidate in natural science, must state the subject in which he is desirous of being examined.

WE regret to have to record the death at Chiswick on the 2nd inst. of Dr. Thomas Anderson, late Professor of Chemistry in the University of Glasgow. Dr. Anderson was born in 1819, and was educated at the University of Edinburgh. On leaving college he visited Stockholm, where he studied for some time under Berzelius, and afterwards went to Giessen and studied under Liebig. Returning to Edinburgh, he acquired considerable reputation by teaching chemistry in the Extra Academic Medical School at Edinburgh, and whilst so engaged received the appointment of Consulting Chemist to the Highland and Agricultural Society. In 1852 he succeeded Dr. Thomas Thomson as Professor of Chemistry in the University of Glasgow, and discharged the duties of the chair with great acceptance until 1869, when he was incapacitated from work by a paralytic seizure. Having had another attack of paralysis in May of the present year, he resigned his professorship in July last. Dr. Anderson was the author of several papers on the organic bases, especially those bases obtained from opium and coal-tar, and in the destructive distillation of animal substances. In a paper on "The Chemistry of Opium," read before the Chemical Society in 1862, he described a valuable method of extracting the alkaloids of opium, and determining their relative qualities.

DR. J. H. SLACK, one of the leading fish-culturists of the United States, and also well known both as a physician and naturalist, died at Bloomsbury, New Jersey, on the 27th of August last.

THE first part is just issued of the "Proceedings of the Physical Society of London," forming a volume of fifty-two pages, illustrated by two plates, and comprising reports of eleven papers read between March 21 and June 20, 1874. Among them is the very important one by Mr. Crookes, "On attraction and repulsion accompanying radiation." The Society meets fortnightly in the Physical Laboratory of the Science Schools at South Kensington, and now numbers about 130 members.

THE Society of Arts commences its winter session next Wednesday, and a busy and useful session it promises to be. There are the general evening meetings of the Society, the Cantor Lectures, the African, Chemical, and Indian Sections, and the Christmas Juvenile Lectures. This Society, as all societies should, seems to be getting more vigorous the older it grows, and between its lectures, its technological examinations, and its prizes, must be doing a great amount of good.

THE New Zealand Government has sent special agents over to England for the purpose of collecting a quantity of small birds of various kinds, and a colony of humble-bees, for introduction into that country. It is expected that the consignment will be ready for despatch in a few days. Another attempt will also be made this year to send a quantity of salmon over to the

antipodes, only 135 salmon being now alive out of the 120,000 salmon eggs which were despatched two years ago.

THE production of opium in Asia Minor, which in former years averaged annually from 2,000 to 3,000 baskets or cases, each containing 150 lbs., has of late years much increased, and the crop now averages from 4,000 to 6,000 baskets. Out of this quantity, which is shipped at Smyrna, the United States take above 2,000 cases. England at one time consumed a large proportion. The Dutch East India Company also for many years have purchased large quantities annually to send to the islands of Java, Batavia, and Sumatra, and of late years the consumption generally has largely increased, especially for North and South America and the West Indies. Turkey opium is always preferred, in England before that of India, as it contains a much higher percentage of morphia than either Indian or Persian; it is on this account that the greater portion of the opium used for medicinal purposes both in Europe and America is the production of Asia Minor. The price of this opium in the market has advanced much of late; fifteen years ago the average price was about 15s. per lb., and it now realises about 17. per lb., though the fair character even of this product has been tarnished by a system of adulteration which has prevailed during the past two years. About 300 cases of this adulterated opium have been sold in the period mentioned, so that purchasers are now very careful from whom they obtain the drug.

OLIVE oil is produced in large quantities in Tunis. The olive crops during the past two years have been so abundant that there is still a great deal of oil in the country, notwithstanding the immense quantities, amounting in all to 3,472 tuns, of the value of 125,893*l.*, that have been shipped during the past year to Great Britain, France, and Italy. It is said that without a great reaction takes place in the oil trade in Europe, vendors in Tunis will be puzzled to know what to do with the supplies they will have on hand. The deposits, or tanks, in the town are said to be capable of containing 6,000 tuns of oil, but they were not clear of the old supplies before the new was ready to be brought in. So far as the working of the native oil-mills is concerned, it is stated that no improvement has taken place. An Italian company contemplates the introduction of a steam mill. For this purpose the British vice-consular house and its premises have been bought, and are to be converted into a mill. Some years ago one was tried at Mehdia, but did not answer. A second was erected near Susa, with the view of buying up the refuse or oil-cake after passing the native mills, and submitting it to further pressure; but this in the hands of the natives blew up.

IT seems to be very probable that the cultivation of sugar in Porto Rico, which has to a great extent succeeded that of cotton, will eventually give place to the growth of coffee on a large scale. Referring to this subject the British Consul says:—"The geographical configuration of the island would almost lead to the anticipation that some less succulent plant than the cane should supersede it in the district of Guayama. Some of the most fertile lands of the island are situated in it, and in favourable seasons no other part of Porto Rico can rival its fecundity; but the island is divided from east to west by a range of mountains, the highest of which, Laquillo, is at the extreme east, and at the southern foot of this mountain Guayama is situated. The trade winds blowing from the north-east cause the rain clouds to strike the northern side of Laquillo, and they are carried along the northern face of the Sierra, a limited portion passing over their summits to the south side. Thus Guayama and Ponce are subject to drought. In the rich and populous district of Ponce this natural impediment has been overcome by an efficient system of irrigation, but Guayama is less favourably situated in all respects;

its position immediately south of Laquillo too often occasions the drought to continue, the soil is burnt up and divested of all fertility, and the residents are neither sufficiently rich nor sufficiently numerous to artificially irrigate their lands as their neighbours in Ponce have done. The consequence is, that the crops are very uncertain in their yield, and it is expected that if something is not done to ensure irrigation, there will very soon be no produce at all."

We have received a copy of the rules of the Metropolitan Scientific Association, the object of which is announced to be "the investigation and promotion of the study of the Physical Sciences, including Astronomy, Geology, Chemistry, the various departments of Natural History, and Biology." Lectures are to be given, and meetings for discussion to be held. The subscription is fixed at 5s. a year for members and 3s. 6d. a year for associates. Mr. W. R. Birt, F.R.A.S., is the president, and the hon. sec., to whom all communications respecting the Association should be addressed, is Mr. C. W. Stidstone, 13, Moorgate Street, E.C.

The ash of the better coals of the American carboniferous age appears to be derived wholly from the plants which formed them. According to analyses by many chemists (quoted by Prof. Dana, in the last edition of his "Geology"), made on lycopods, ferns, equisetia, mosses, conifera, &c., there is in them an average quantity of silica and alumina, such that if the plants were converted into coal it would amount to 4 per cent. of the whole, and the whole ash would be 4.75. Many analyses of bituminous coal show but 3 per cent. of ash and 4.5 is an average. Hence it follows:—(1) That the whole of the impurity in the best coals may have been derived from the plants; (2) the amount of ash in the plants was less than the average of modern species of the same tribes; (3) the winds and waters for long periods contributed almost no dust or detritus to the marshes. In that era of moist climate and universal forests there was hardly any chance for the winds to gather dust or sand for transportation.

The *Medical Press* draws attention to a new tonic medicine under the name of *Boldo*. The tree is said to be found on isolated mountain regions in Chili; the bark, leaves, and blossoms possessing a strong aromatic odour, resembling a mixture of turpentine and camphor. The leaves contain also a large quantity of essential oil. The alkaloid obtained from the plant is called "Boldine." Its properties are chiefly as a stimulant to digestion and having a marked action on the liver. Its action was discovered rather accidentally—thus: some sheep which were liver diseased were confined in an inclosure which happened to have been recently hedged with boldo twigs. The animals ate the leaves and shoots, and were observed to recover speedily. Direct observations prove its action: thus, one gramme of the tincture excites appetite, increases the circulation and produces symptoms of circulatory excitement, and acts on the urine, which gives out the peculiar odour of boldo. Though we have not seen any specimens of the boldo as imported, there seems little doubt but that it is the *Boldoa fragrans*, a Monimiaceous tree, the Chilean name of which, however, is usually written *Boldu*. The leaves, which are rough, are opposite, ovate, and are borne on short stalks. The plant is dioecious, and the flowers are borne in axillary racemes. All parts of the tree are fragrant; hence its specific name. The little berries are eaten, the bark is used for tanning, and the wood is considered by the natives superior to any other for making charcoal.

A LARGE monumental fountain, ornamented by the celebrated sculptor Carpeaux, has been erected on the Observatoire Place at Paris. It represents Europe, Asia, Africa, and America rotating the globe, which they carry on their heads, and is very effective; but in spite of M. Le Verrier's protestations, they are

rotating the globe from east to west, according to the Ptolemean theory.

THE Khedive of Egypt has given his cordial support to the English Government Transit of Venus Expedition in Egypt. He has furnished the principal station on Mokattam Heights, 600 ft. above Cairo, with tents, a guard, and a mounted escort, and is making a telegraph line to connect that station with Greenwich, through the Submarine, Gibraltar, and Malta Cable. His Highness has also sent a steamer to tow the Thebes branch of the expedition to their destination, and he has brought all the huts and instruments up by special train from Suez.

SIR DOUGLAS FORSYTH'S Yarkand curiosities, illustrative of the ethnology of the regions he visited, will be shortly sent from India to South Kensington.

WE are glad to see that Mr. T. H. Ince, furrier, of Oxford Street, has entered the lists as a technical educator, having just issued a neat booklet containing well-compiled, and on the whole trustworthy, information concerning the animals whose skins he makes use of in his trade. Many who read Mr. Ince's brochure will be surprised at the great variety of animals, both British and foreign, whose skins are, in one way or another, turned to the uses of an advanced and luxurious civilisation.

AT its last sitting the Council of the Paris Observatory declared that the Meridian Service is not in a good condition. M. Leverrier, therefore, has written to the Minister for Public Instruction, advising him to ask M. Leewy, a member of the Institute, and the head of the Meridian Service, to resign if he does not give up the direction of the *Connaissance des Temps*—both offices being too much for one man, however zealous and learned.

AN immense number of errors have been discovered by M. Leverrier in the stellar observations, which were ready for printing, and which were made before the reorganisation of the Paris Observatory was completed. All these observations will be subjected to a most careful scrutiny, and many will be rejected altogether. The correct observations will not be printed before further reductions are made. A special credit of 15,000f. will be asked from the National Assembly for that special purpose, and will certainly be granted.

THE several French public administrations have received instructions to favour men who have been non-commissioned officers in the army in making subsidiary appointments in their offices. In some cases competitive examinations will be established for these places.

THE tanks of the Manchester Aquarium have just been enriched by a remarkably fine specimen of the Angler (*Lophius piscatorius*), over 4 ft. in length. The fish is in the best possible condition, and was obtained by the curator, Mr. W. Saville Kent, from the Royal fish weirs at Colwyn Bay. It is the first and only example of the species on exhibition at any of the many aquaria now established, and many interesting data will no doubt be derived from the observation of its habits for the first time in confinement.

THE additions to the Zoological Society's Gardens during the past week include a Nisnas Monkey (*Cercopithecus pyrrhonotus*) from Nubia, presented by Dr. R. F. Mayne; a Bengalese Leopard Cat (*Felis bengalensis*) and an Egyptian Cat (*Felis chaus*) from India, a Leadbeater Cockatoo (*Cacatua leadbeateri*) from Australia, deposited; a pair of Bar-headed Geese (*Anser indicus*) from India, and three Night Parrots (*Stringops habroptilus*) from New Zealand, purchased. These last-named birds form the finest collection of the species ever seen in this country.

THE EXPLORATION OF THE ARCTIC  
REGIONS\*

TEN years ago, when arctic exploration was sought to be revived by the Royal Geographical Society, all, I think, were agreed as to the main points of the subject, while a diversity of opinion arose regarding one point, which appears to me only of secondary importance now—namely, the route to be chosen. There was a great deal of discussion upon this point, and whether it would be more advisable for a new English expedition to proceed west of Greenland up Smith Sound, or east of it, anywhere in the wide sea between Greenland and Novaya Zemlya.

From the results arrived at by actual exploration since 1865, and the light shed by it upon the subject, it appears to me that a real ground for any such diversity of opinion no more exists, as the most noteworthy fact brought out by the various recent polar expeditions is a greater navigability in all parts of the arctic seas than was formerly supposed to exist.

For my part, I readily admit that the Smith Sound route has turned out to be a great deal more practicable and navigable than could formerly be surmised from the experience of Kane and Hayes. Certainly both these attempts were made with insufficient means, Kane's *Advance* being only a sailing brig, heavily laden and blown about by unusually strong gales, and Hayes' schooner, the *United States*, a mere sailing vessel of 133 tons, not fit for navigation in the arctic seas. When, therefore, Hall in 1871 tried this route with the *Polaris*, he achieved most astounding results, for he sailed and steamed from Tessiusak without interruption in one stretch through the ill-famed Melville Bay, Smith Sound, Kennedy Channel, and into new seas as far as 82° N. lat., a distance of 700 miles, with the greatest ease in seven days, and even reached beyond the 82nd parallel. Yet his vessel, the *Polaris*, was only a small, weak-powered steamer, by no means well fitted for the work, and manned by a motley crew, hampered by Eskimo families and little children.

While I thus readily admit my expectations to have been far exceeded by recent experience, similar progress has also been made on all the other routes into the central area of the arctic regions, and a great deal has been achieved, even with small means. From the results already arrived at, it is evident that with appropriate steam-vessels, making use of the experience gained, that central area will be penetrated as far as the North Pole, or any other point.

As I cannot but think that an English exploring expedition will soon leave for the arctic regions, I take this opportunity to state to you explicitly that I withdraw everything I formerly said that might be construed into a diversity of opinion on the main points at issue, and that I now distinctly approve beforehand of any route or direction that may be decided on by a new expedition by British geographers.

For those expeditions which I myself have been able to set on foot since 1865, the most direct and shortest routes and the nearest goals seemed the most advisable, as only very small means could be raised, and these chiefly by promising to break new ground and open new lines of research never before attempted. With the same small means at my command, we could not have done as much as we did elsewhere. At my instance, more or less, seven very modest expeditions and summer cruises went forth. The first one, a reconnoitring tour in 1868 under Captain Koldeway, consisted of a little Norwegian sloop of only about sixty tons, no bigger than an ordinary trawling smack; she was purchased at Bergen, received the name of *Germania*, and went towards East Greenland, then to the east of Bear Island, on to the north of Spitzbergen beyond the 81st parallel, and surveyed portions of East Spitzbergen not before reached by English or Swedish expeditions. Next year, 1869, started the so-called second German expedition, consisting of two vessels, a screw steamer of 143 tons, called the *Germania*, and a sailing brig of 242 tons, called the *Hansa*, as a tender; they went again to East Greenland, explored this coast as far as 77° N. lat., and discovered a magnificent inlet, Franz-Joseph Fjord, extending far into the interior of Greenland, navigable, and the shores of it enlivened by herds of reindeer and musk oxen. It was also shown that the interior of Greenland in this region consists not of a slightly elevated table-land, as formerly supposed, but of splendid mountain masses of Alpine character. The account of this expedition, which also wintered on the coast of East Greenland in 72½° N. lat., is before you in an English dress.

\* A letter addressed to the President of the Royal Geographical Society, a copy of which has been forwarded to us by Dr. Petermann.

Besides this, I got my friend Mr. Rosenthal, a shipowner, to allow two scientific men, Dr. Dorst and Dr. Bessels, to accompany two of his whaling steamers, one to explore the seas east of Spitzbergen, the other those east of Greenland; both made highly interesting and valuable scientific observations, which have not yet been published. In 1870 my friends Baron Heuglin and Count Zeil went from Tromsø in a small schooner of thirty tons to East Spitzbergen, and collected most interesting information on a region never before visited by scientific men; and when Baron Heuglin had been out a second time, the next following year (1871), again with one of Rosenthal's expeditions, he published a valuable work in three volumes. In the same year Payer and Weyprecht went in the *Isbjørn*, a sailing vessel of forty tons, from Tromsø, to explore still further northward than Bessels the sea east of Spitzbergen, which was done with great success as high up as 78° 43' N. lat. (in 42½ E. Long. Gr.) and as far east as 59° E. long. The scientific results of this cruise have also not yet been fully worked out.

Thus from the interior of Greenland, in 30° W. long. to 59° E. long. east of Spitzbergen, a width of about ninety degrees of longitude has been explored, and highly interesting results obtained. The cost of these seven expeditions and cruises was about 140,000 thalers, or altogether 20,000l., of which 5,000 thalers, or 750l., were contributed by the Government of Germany; all the rest by private individuals, my friend Rosenthal spending upwards of 30,000 thalers. Half of the results of these expeditions have not yet been published, but the work of the second German expedition in four volumes, and that by Baron Heuglin in three volumes, are finished, and are, I think, a credit to the explorers.

I have mentioned these details in order to show that such endeavours to extend human knowledge, improve the spirit of the navy, and foster a taste for the progress of science, are not necessarily expensive. A really effective expedition will cost more, but also accomplish more; in this respect a reviewer in the *Athenæum*, in reviewing our second expedition, says that "to start on expeditions such as these in vessels ill-adapted, ill-strengthened, ill-found, and ill-provisioned, is but to court failure;" to which I say Amen.

One well-appointed English expedition of one or two strong steamers may well be able to penetrate to the furthest points of our globe. Even the whaling ships, now furnished as they are with steam, penetrate as a rule to where it was thought impossible for such a fleet to pursue their valuable fisheries; the ill-famed middle ice of Baffin's Bay is to them no more impenetrable, and extreme points reached by former discovery expeditions in the course of a long series of years are now visited and passed by one whaling vessel in the course of a few summer months.

Up to 1869 the general opinion was that from Bear Island in 74½° N. lat. there extended the line of heavy impenetrable pack-ice eastward as far as Novaya Zemlya; that, working along this coast, the furthest limit of navigation was at Cape Nassau; and that the Kara Sea was entirely and always filled with masses of ice, totally impracticable for any navigation. But the Norwegians, with their frail fishing-smacks of only thirty tons at an average, have for five consecutive years every year navigated all those seas hitherto considered as totally impenetrable; they have repeatedly circumnavigated the whole of Novaya Zemlya, crossed the Kara Sea in every direction, penetrated to the Obi and Yenisei, and shown beyond the shadow of a doubt that navigation can generally be pursued there during five months of the year, from June to October, and moreover, that the whole of the Kara Sea and the Siberian Sea far to the north are every year more or less cleared of their ice, both by its melting and drifting away to the north. I have had the journals of many of these cruises sent to me from Norway, containing a mass of good observations made at the instance of the Government Meteorological Office under the superintendence of Prof. Mohn, at Christiania. If another proof of confirmation were wanting, it has been furnished by Mr. Wiggins, of Sunderland, who this summer also navigated through the Kara Sea as far as the mouth of Obi.

As to the sea between Novaya Zemlya and Spitzbergen, the very first time in our days its navigation was attempted, namely, by Weyprecht and Payer in 1871, it was found navigable even in a small sailing vessel of forty tons up to 79° N. lat., and in the eastern half of it no ice whatever was met with. The experience of their last expedition in 1872 certainly has been the reverse, as they encountered much and dense ice, at least in the direction of Cape Nassau; but it would lead to erroneous conclusions, if it were not taken into account that the Norwegians at



the same time found the western half of that sea quite free of ice.

I am not going to make any remark upon the late Austrian expedition, as its results and observations are not sufficiently before us, but I am authorised by a letter of Lieut. Weyprecht, the nautical commander, dated the 1st November, to state that, before he has published his extensive observations, he warns against all premature conclusions, and concludes the letter which I shall publish in the next part of the *Mittheilungen*, and in which he expresses his own views on the arctic question for the first time, with the sentence "that he considers the route through the Siberian Sea as far as Behring Strait as practicable as before, and would readily take the command of another expedition in the same direction."

I believe myself that the navigability of the seas to the north of Novaya Zemlya can as little be called in question by this one drift of the Austrian expedition, as the navigability of Baffin's Bay by the drifts of De Haven, M'Clintock, and the crew of the *Polaris*. These drifts by no means prevent others from penetrating the same seas.

And here I may be allowed to refer in a few words to the other end of this route, the sea north of Behring Strait. Capt. Cook in 1778, and his second in command, Capt. Clerke, in 1779, believed to have reached the extreme limit of navigation by attaining Icy Cape (in  $70\frac{1}{2}^{\circ}$  N. lat.) on the American, and North Cape (in  $69^{\circ}$  N. lat.) on the Asiatic side, and they considered further attempts there as madness as well as to any practical purpose useless. Capt. Beechey, however, with his lieutenant, the present Admiral Sir Edward Belcher, penetrated already in 1826 as far as Point Barrow, and expressed the result of his experience in the weighty sentence: "I have always been of opinion that a navigation may be performed along any coast of the Polar Sea that is continuous."\* And, true enough, many a follower has sailed along the whole of the northernmost coast of America, though exposed to the pressure of the immense pack-ice masses from the north impinging upon these coasts. Capt. Kellett, with the *Hevald*, a vessel not intended for ice navigation, penetrated in 1849 with ease to  $72^{\circ} 51'$  N. lat. into the Polar Sea so much dreaded by Cook and Clerke, discovered Herald Island, and what is now called by some Wrangel Land, and found the ice not at all so formidable as supposed previously. Going over the similar experience of Collinson, Macure, Rodgers, and others, we come to the time when the Americans established a highly profitable whale fishery in seas considered entirely useless by Cook and Clerke, gaining as much as \$8,000,000 in two years. It was in one of these years that a shipmaster went as far as  $74^{\circ}$  N. lat., nearly due north of Herald Island, and saw peaks and mountain ranges far to the northward of his position. Another, Capt. Long, went a considerable distance along the Siberian coast to the west, and did more in a few days with a sailing vessel than Admiral Wrangel had been able to accomplish with sledges in winter in the course of four years, in the same region. In a letter dated Honolulu, 15th January, 1868, he says:—"That the passage from the Pacific to the Atlantic Ocean will be accomplished by one of the routes I have indicated I have as much faith in as I have in any uncertain event of the future, and much more than I had fifteen years ago in the success of the Atlantic Telegraph. Although this route will be of no great importance to commerce as a transit from one ocean to the other, yet could the passage along the coast as far as the mouth of the Lena be successfully made every year (which I think probable) it would be of great benefit in developing the resources of Northern Siberia."†

To the north-east of Spitzbergen, also, an interesting cruise was recently made by Mr. Leigh Smith, who in 1871, with only a sailing schooner of 85 tons, reached as far as  $27^{\circ} 25'$  E. of Greenwich in  $80^{\circ} 27'$  N. lat.,  $4^{\circ}$  of longitude further than any authenticated and observing navigator before him. At this point he had before him to the east—consequently in the direction of the newly-discovered Franz-Joseph Land—nothing but open water on the 6th of September, 1871, as far as the eye could reach.

That land would be found in the locality where the Austrian Expedition actually found it, I have long predicted. Gillis Land, after Keulen's map generally considered to be situated in  $80^{\circ}$  N. lat.,  $30^{\circ}$  E. long., by the Swedish explorers erroneously put down in  $79^{\circ}$  N. lat., I have from the original text concluded to be in  $81\frac{1}{2}^{\circ}$  N. lat. and  $37^{\circ}$  E. long. Greenwich. This approaches

to within eighty nautical miles of Franz-Joseph Land, which was sighted westward as far as  $46^{\circ}$  E. long.; but in this longitude there was not as yet any limit of the land. The flight of immense numbers of Brent-geese and other birds in the same direction has long been observed by various voyagers, and it has also been noticed that not only migrations of birds but also of mammals take the same direction; the Norwegian fishermen on the north of Spitzbergen have repeatedly caught immense numbers of walrus and ice-bears at the Seven Islands, and especially on their north-eastern side, whereas at Spitzbergen the walrus is now very scarce and the ice-bear almost extinct.

I consider it also highly probable that that great arctic pioneer and navigator William Baffin may have seen the western shores of Franz-Joseph Land as long ago as 1614, for in that year he proceeded to  $81^{\circ}$  N. lat., and thought he saw land as far as  $82^{\circ}$  to the north-east of Spitzbergen (which is accordingly marked in one of Purchas's maps.\* It is true the account of this voyage is very meagre, but so is the account of his voyage and still greater discovery of Baffin's Bay two years after, which Sir John Barrow calls "the most vague, indefinite, and unsatisfactory," and on his map leaves out Baffin's Bay altogether, and this, be it observed, in the year 1818!† Barrington and Beaufoy, though inserting Baffin's discoveries in their map dated March 1, 1818, describe them in the following words:—"Baffin's Bay, according to the relation of Mr. Baffin in 1616, but not now believed!"‡ With Barents's important voyages and discoveries it is exactly the same. The Russians, who only navigated as far as Cape Nassau, also tried to erase Barents's discoveries from the map and cut off the north-eastern part of Novaya Zemlya altogether.‡ But old Barents has been found more trustworthy and correct than all the Russian maps and pilots put together. Even the identical winter hut of that great Dutch navigator, nearly 300 years old, has been found by the Norwegian Capt. Carlsen on Sept. 9, 1871, and many interesting relics brought home by him; so that the truth and correctness of those famous old Dutch voyages has been proved beyond all doubt. In like manner, Baffin's voyage to within sight of the western shores of Franz-Joseph Land may be considered trustworthy until some substantial proof of the contrary is brought forward. Nay, it even appears to me that the report given of another remarkable voyage of a Dutch navigator, Cornelis Roule, merits attention and is to be considered in the same way as Baffin and Barents; so that if it be as true as the voyages of these navigators, it may yet be found that Franz-Joseph Land was already discovered and sailed through up to  $74\frac{1}{2}^{\circ}$  or  $75^{\circ}$  N. lat. nearly 300 years ago. This report runs thus:—"I am informed with certainty that Capt. Cornelis Roule has been in  $84\frac{1}{2}^{\circ}$  or  $85^{\circ}$  N. lat. in the longitude of Novaya Zemlya, and has sailed about forty miles between broken land, seeing large open water behind it. He went on shore with his boat, and from a hill it appeared to him that he could go three days more to the north. He found lots of birds there and very tame."§ Now, the main longitude of Novaya Zemlya is  $60^{\circ}$  E. Greenwich, and passes right through Austria Sound and Franz-Joseph Land; the latter is a "broken land" also, behind which Lieut. Payer saw "large open water," and found "lots of birds!"

Be this as it may, we now come to Sir Edward Parry's voyage north of Spitzbergen, regarding which it is an undoubted fact that he reached  $82^{\circ} 45'$  N. lat., the furthest well authenticated point yet reached by any navigator, and a feat unsurpassed to this day.

There is, however, no doubt that the northern coast of Spitzbergen lies just in the teeth of one of the most formidable ice-currents, and one that summer and winter is sweeping its ice masses just towards these coasts. If, therefore, an English expedition should take Spitzbergen as a basis to start from, it would require two vessels, one of which ought to go up the west coast, the other up the east coast; for when northerly and westerly winds prevail, the first vessel would probably be hampered by ice, and the second vessel find it navigable up the east coast, and if easterly and southerly winds prevailed, the reverse would be the case.

\* Barrington and Beaufoy, pp. 40 and 41.

† Barrow, "Chronological History," p. 216 and map.

‡ This was actually attempted by a pilot of the "Russian Imperial Marine," and found its way also into vol. viii. of the Journal of the R. G. S., p. 414, where the map is spoken of as "showing the actual outline of its works, as traced by the pilot Ziwlowska, from the latest examinations, by which it will be seen that more than the eastern half represented on our maps has no existence in reality!"

§ Wilsen, N. and O. Tartarye, folio 1707, 2 decl., p. 920. See also Proc. R. G. S. ix. p. 178.

\* Beechey: Voyage, vol. ii. p. 297.

† Nautical Magazine, 1868, p. 242.



It is by way of Smith Sound, however, that navigation has hitherto been pushed furthest, and here an English expedition, so long projected, may well operate. At the same time the east coast of Greenland seems still worthy of attention. The second German expedition did not proceed far to the north, it is true, but it was easy enough to reach the coast, and Lieut. Payer told me this was merely something like a "cab drive." Capt. Gray, of Peterhead, a most experienced arctic navigator, wrote already in 1868 thus:—"Having for many years pursued the whale fishery on the east coast of Greenland, and observed the sides, the set of currents, and the state of the ice in that locality at various seasons of the year, I think that little if any difficulty would be experienced in carrying a vessel in a single season to a very high latitude, if not to the pole itself, by taking the ice at about the latitude of 75°, where generally exists a deep bight, sometimes running in a north-west direction upwards of 100 miles towards Shannon Island, from thence following the continent of Greenland as long as it was found to sound in the desired direction, and afterwards pushing northwards through the loose fields of ice which I shall show may be expected to be found in that locality. The following are the reasons on which that opinion is founded:—In prosecuting the whale fishery in the vicinity of Shannon Island there are generally found loose fields of ice, with a considerable amount of open water, and a dark water sky along the land to the northward; the land water sometimes extending for at least fifty miles to the eastward; and, in seasons when south-west winds prevail, the ice opens up very fast from the land in that latitude. The ice on the east coast of Greenland is what is termed field or floe ice, the extent of which varies with the nature of the season; but it is always in motion, even in winter, as is proved by the fact that ships beset as far north as 78° have driven down during the autumn and winter as far south as Cape Farewell. Thus there is always the means of pushing to the northward by keeping to the land ice, and watching favourable openings."

And quite recently, in communicating the result of his experience the present year, he writes:—"During the past season I had too many opportunities of observing the drift of the ice. In May, June, July, and August, its average drift was fully four times miles a day; in March and April it must have been driving double that rate. I calculate that nearly the whole of the ice was driven out of the arctic basin last summer. I went north to 70° 45' in August, and found the ice all broken up, whereas down in 77° the floes were lying whole in the sea, clearly showing that the ice in 80° must have been broken up by a swell from the north, beyond the pack to the north, which I could see over; there was a dark water sky reaching north until lost in the distance, without a particle of ice to be seen in it. I was convinced at the time, and so was my brother, that we could have gone up the pole, or at any rate far beyond where anyone had ever been before. I bitterly repent that I did not sacrifice my chance of finding whale and make the attempt, although my coals and provisions were wearing down. Although I have never advocated an attempt being made to reach the pole by Spitzbergen, knowing well the difficulties that would have to be encountered, my ideas are now changed from what I saw last voyage. I am now convinced that a great advance towards the pole could occasionally be made without much trouble or risk by Spitzbergen, and some of our amateur navigators will be sure to do it and pluck the honour from the Royal Navy. I do not know if the *Eclipse* will be sent to the Greenland whale fishery next year; if I go I shall be able to satisfy myself more thoroughly as to the clearing out of the ice this year, because it will necessarily be of a much lighter character than usual."

If this important information should be considered worthy the attention of the British geographers and the Admiralty, there would, perhaps, be two steamers sent out to make success doubly certain, one to proceed up the west coast of Greenland by way of Smith Sound, the other up the east coast of Greenland.

But whatever may be decided on, I trust that the British Government will no longer hold back to grant what all geographers and all scientific corporations of England have been begging for these ten long years, and afford the means for a new effective expedition to crown these, our modest endeavours, of which I have given an outline. We in Germany and Austria have done our duty, and I am happy to have lived to see that our humble endeavour, the work of our arctic explorers, have

gained your approbation—that of the Royal Geographical Society of Great Britain. We have done all we could in the private manner we had to do it; for, as a nation, we Germans are only now beginning to turn our attention to nautical matters. We have had no vessels, no means, and our Government has had to fight three great wars these ten years. But, nevertheless, we have had in this interval German, Austrian, American, Swedish, Norwegian, Russian polar expeditions, of which even an Italian officer took part at the instance of the Italian Government. And England, formerly always taking the lead in these matters, is almost the only maritime power that has kept aloof. When, nearly thirty years ago, one man of science proposed that magnetical observations should be extended, it was at once answered by the Government then by sending out to the antarctic regions an expedition of two vessels, the *Erebus* and *Terror*, under that great navigator, Sir James Clarke Ross, which has never yet been eclipsed as to the importance of its results and the lustre it shed on the British Navy. I do not know the views held in England now, but I know that to us outsiders the achievements and work of a man like Sir James Clarke Ross or Livingstone has done more for the prestige of Great Britain than a march to Coomassie, that cost nine millions of pounds sterling. That great explorer, Livingstone, is no more; his work is going to be continued and finished by German and American explorers; we shall also certainly not let the arctic work rest till it is fully accomplished, but it surely behoves Great Britain now to step in and once more to take the lead.

AUGUSTUS PETERMANN,  
Hon. Cor. Member and Gold Medallist,  
Royal Geographical Society.  
Gotha, Nov. 7, 1874

## SOCIETIES AND ACADEMIES

### LONDON

**Chemical Society, Nov. 4.**—Dr. Odling, president, in the chair.—The following papers were read:—On methyl-hexyl-carbinol, by Dr. C. Schorlemmer; On the action of organic acids and their anhydrides on the natural alkaloids, Part I., by Dr. C. R. A. Wright; On the action of bromine in the presence of water on bromopyrogallol and on bromopyrocatechin, by Dr. J. Stenhouse; The action of baryta on oil of cloves, by Prof. A. H. Church; Observations on the use of permanganate of potash in volumetric analysis, and on the estimation of iron in iron ores, by Mr. E. A. Farnell; Further researches on bilirubin and its compounds, by Dr. J. L. W. Thudichum.

**Zoological Society, Nov. 3.**—Dr. A. Günther, F.R.S., vice-president, in the chair.—The secretary read a report on the additions that had been made in the Society's menagerie during the months of June, July, August, and September, 1874.—Mr. Sclater gave an account of some visits he had recently made to several zoological gardens and museums in France and Italy, and made remarks upon some of the principal objects noticed therein.—Mr. G. Dawson Rowley exhibited and made remarks upon some rare birds from New Zealand, amongst which were fine examples of *Apteryx haasti*, and a living pair of *Sceloglaux albifacies*.—Mr. A. R. Wallace exhibited some rhinoceros horns obtained in Borneo by Mr. Everett, proving that this animal was still found living in that island.—Mr. J. Gould exhibited a new parrot, of the genus *Aproornis*, recently obtained on the Darling Downs, in Queensland. Mr. Gould proposed to call this bird *Aproornis insignisissimus*.—A letter from Mr. Swinhoe was read respecting some bats obtained by him at Ningpo.—A communication was read from M. L. Taczanowski, conservator of the museum at Warsaw, in which he gave a list of the birds collected by M. Constantine Jelski in the central part of Western Peru. Amongst these were eighteen species described as new to science.—A communication was read from Mr. Frederick Moore, giving descriptions of some new Asiatic Lepidoptera.—A communication was read from Mr. George Gulliver, containing measurements of the red corpuscles of the blood of *Hippopotamus amphibius*, *Otaria jubata*, and *Trichechus rosomarus*.—Mr. R. Bowdler Sharpe read a paper entitled "Contributions to a history of the Accipitres, or birds of prey." The first of this series contained notes on the females of the common and South African kestrels.—A communication was read from Mr. Henry Adams, giving the descriptions of some new species of shells from various localities, also of a new genus of Bivalves from Mauritius.—Mr. A. H. Garrod read a paper on points in the anatomy of the parrots which bear on the classification of the sub-order. This

\* Proc. R. G. S., vol. xii. p. 197.

† Letter of Capt. David Gray to Mr. Leigh Smith, dated Peterhead, Sept. 21, 1874.

memoir was based upon the examination of a large number of individuals belonging to seventy-nine species, chiefly from the Society's living collection, and contained a new arrangement of the group based principally upon the arrangement of the carotid arteries, and the presence or absence of the *ambicus* muscle, the furcula, and the oil-gland.—A communication was read from Mr. G. B. Sowerby, jun., giving the descriptions of five new species of shells from different localities.—A communication was read from Mr. E. P. Ramsay, wherein he described five new species of Australian birds, and of the egg of *Chamydodera maculata*. The birds described were—*Cypselus terra-regine*, *Alucardus maculosus*, *Ptilotis frenata*, *Eopsaltria inornata*, and *Rhipidura superciliosa*.

**Royal Microscopical Society, Nov. 4.**—Chas. Brooke, F.R.S., president, in the chair.—A paper by Dr. Jas. Fleming, On microscopic leaf-fungi from the Himalayas, was taken as read; it was illustrated by drawings, and many of the species described had been identified by Mr. M. C. Cooke as being the same as those known in Europe.—A paper by the Rev. W. H. Dallinger and Dr. Drysdale, in continuance of their series. On the life history of Monads, was read by the secretary. It minutely described a form repeatedly met with in macerations of the heads of codfish and salmon, and traced the development and reproduction in all stages, and was illustrated by drawings, which were enlarged upon the black board by Mr. Chas. Stewart. The observations had extended over several years, and had been conducted with the greatest care under various powers up to  $\frac{1}{2}$  in. The results of experiments were also given, and conclusively showed that exposure to temperatures of 220° and 300° F. had failed to destroy the germs of these organisms. Some interesting living objects, stated to be larval forms of the common cockle, were exhibited and described by Mr. Wood; but the similarity of these forms to some which were exhibited at the previous meeting, and presumed to be *Bucphalus polymorphus*, having been pointed out by Mr. Stewart, an interesting discussion followed. *Pyrrhia pulcherrima*, Kitton, was exhibited under one of the Society's instruments.

## PARIS

**Academy of Sciences, Oct. 26.**—M. Bertrand in the chair.—The following papers were read:—Note on Dr. Zenker's cometary theory, by M. Faye. The theory commented upon supposes that comets owe their movements in part to the attractive force of the sun and in part to the evolution of gases from the surface of the comet by the action of the sun's heat. The gases are supposed to consist of water vapour, and a hydrocarbon, and the motion produced by their rapid generation from the surface of the comet nearest to the sun is regarded as of an opposite nature to that produced by gravitation. M. Faye dissents from these views, and promises a further examination of the question in a future paper.—Note on the average ration of the French countryman, by M. Hervé Mangon. The author concludes, from a statistical inquiry into the subject, that the daily ration of the French labourer is not sufficiently high, and that for the welfare of the country this ration should be increased.—On the composition and physical properties of the products from coal-tar, by M. Dumas. The analyses and experiments were undertaken by the author with a view to test the insecticidal properties of coal-tar as applied to the destruction of Phylloxera. The hydrocarbons appear to have the most energetic action, the portion boiling below 110° causing death in five minutes.—Presentation of the geographical programme forming part of the new plan of studies for the colleges, by M. E. Levasseur.—On the analytical theory of Jupiter's satellites, by M. Souillart. The author had given, in a previous memoir, the formulae for calculating the inequalities of longitude and of the *radial vectors* of the satellites. In the present memoir the problem has been solved for the latitudes and the secular equations of the longitudes.—Eighth note on the electric conductivity of bodies which are imperfect conductors, by M. Th. du Moncel.—On the fermentation of apples and pears, by M. M. G. Lechartier and F. Bellamy. The experiments described have been carried on since 1872, and are considered by the authors as a veritable demonstration of Pasteur's deduction from his theory of fermentation, that "the formation of alcohol is due to the fact that the chemical and physical life of the fruit-cells is continued under new conditions in a similar manner to those of the cells of the ferment."—Absorption of gas by iron wire heated to redness and thinned by immersion in dilute sulphuric acid during the operations of wire-drawing, by M. D. Sévoz. The author has not yet determined the nature of this

gas.—On the isomerism of acetylene perbromide and the hydride of tetrabrominated ethylene, by M. E. Bourgoïn. The last-named substance is obtained by the action of bromine and water on bibromosuccinic acid, and is described as a crystalline substance melting at 54°5'. Perbromide of acetylene is a liquid formed when acetylene is passed into bromine heated to 50° under a layer of water. The author considers acetylene perbromide to be an additive compound of the acetylene series, while the other substance is derived by substitution from ethylene or ethyl hydride.—Researches on the decomposition of certain salts by water; second note, by M. A. Ditte. The author has now studied the decomposition bismuthous and bismuthic nitrates and of antimonious chloride.—On electro-magnets; a note by M. Deleuil. This paper refers to the use of electro instead of ordinary magnets for removing iron from the paste employed in the manufacture of porcelain.—Researches on the fleece of merino sheep, by M. A. Sanson.

**Geographical Society, Oct. 21.**—President, M. Delesse.—Dr. Hamy communicated the result of his researches on the geographical distribution of the human race in Eastern Melanesia. He showed that the penetration of the Papuan populations by the Polynesians is much less exceptional than has been hitherto believed. It has been long known that there has been a considerable immigration of Tongans into Viti. Ouvea, in the Loyalty Islands, was invaded at the beginning of this century by Kanakas from the Wallis Isles, the eastern coast of New Caledonia containing a very large number of Melano-Polynesian Metis, the yellow variety of M. Bougarel, who perhaps found them on Isabella Island, in the Solomon group. The recent discoveries of Captain Moresby show the Polynesians strongly established in the southern extremity of New Guinea. According to M. J. Verreau they had penetrated as far as Australia, where a small tribe having all the characteristics of Polynesians has been established for about thirty years in the neighbourhood of Cape Capricorn.

## BOOKS AND PAMPHLETS RECEIVED

**BRITISH.**—Tables for Travellers: Admiral Bethune (W. Blackwood).—Out of Doors: Rev. J. G. Wood, M.A., F.L.S. (Longmans).—Charts of Meteorological Data. (Meteorological Office).—Remarks on Charts of Meteorological Data. (Meteorological Office).—Insects Abroad: Rev. J. G. Wood, M.A., F.L.S. (Longmans).—The Races of Mankind, vol. ii.: Robert Brown, M.A. (Cassell, Petter, and Co.).—The Earth as Modified by Human Action: G. P. Marsh (Sampson Low and Co.).—The German Arctic Expedition of 1873-74: Capt. Koldever (Sampson Low and Co.).—The Sheep: W. C. Spooner, M.R.V.C. (Lockwood and Co.).—A Year's Botany: Frances Anna Kitchner (Rivingtons).—The Safe Use of Steam. By an Engineer (Lockwood and Co.).—Observations of Magnetic Declination: J. A. Brown, F.R.S. (H. S. King and Co.).—The Elements of Psychology: Robert Jardine (Macmillan and Co.).—Winter and Spring on the Shores of the Meditteranean: James H. Bennett (J. and A. Churchill).—Physiological Chemistry: S. W. Moore (Smith, Elder, and Co.).—Philosophy of History: Hugh Doherty, M.D. (Trübner and Co.).

**AMERICAN.**—Proceedings of the Boston Society of Natural History, vol. xvi. Part IV.—Memoirs of the Boston Society of Natural History, vol. ii. No. 3.—Address of Ex-President Joseph Lovering, American Institute for the Advancement of Science at Hartford.

## CONTENTS

	PAGES
SIR JOHN LEBECK AT BIRMINGHAM . . . . .	21
THE NATURAL HISTORY OF SPITZBERGEN AND NOVA ZEMBLA . . . . .	22
HÆCKEL'S DEVELOPMENT OF MAN, II. By Dr. PVE-SMITH . . . . .	22
ISMAILIA (With Illustration) . . . . .	24
LETTERS TO THE EDITOR:—	
Endowment of Research.—GEORGE DARWIN . . . . .	27
The University of London.—PHILIP MAGNUS . . . . .	27
Gresham Lectures.—MAURICE LICHTENSTEIN . . . . .	28
Insects and Colour in Flowers.—F. T. MOTT: JOSEPH JOHN MURPHY . . . . .	28
Locomotion of Medusæ.—GEORGE J. ROMANES . . . . .	29
Suicide of a Scorpion.—G. BIDDE . . . . .	29
THE AMU EXPEDITION (With Illustrations) . . . . .	29
MEMORIAL TO JEREMIAH HORROCKS . . . . .	31
FERTILISATION OF FLOWERS BY INSECTS, VII. By Dr. HERMANN MÜLLER . . . . .	31
THE CHEMISTRY OF CREMATION . . . . .	33
A NEW MATERIAL FOR PAPER . . . . .	33
NOTES . . . . .	34
THE EXPLORATION OF THE ARCTIC REGIONS. By Dr. PETERMANN . . . . .	37
SOCIETIES AND ACADEMIES . . . . .	39
BOOKS AND PAMPHLETS RECEIVED . . . . .	40

THURSDAY, NOVEMBER 19, 1874

## ELIE DE BEAUMONT

THE life of the science of geology has been short; that of many of its illustrious votaries has been long. There still survive a few whose recollections go back to the early triumphs of the science in the days of William Smith and Cuvier. But their number grows rapidly less. One by one the links which bind us personally with the glories of the past are being snapped asunder. The grand old oaks under whose branches the younger saplings have grown up are fast dropping down. Within the last few years we have lost in this country our Murchison, Sedgwick, and Phillips; Austria her Haidinger; Germany her Gustav Rose, Bischof, and Naumann; America her Agassiz, and France her D'Archiac and De Verneuil. To this list we have now to add the well-known name of L. Elie de Beaumont. To the expressions of regret with which the friends and pupils of that father in science have followed his remains to the tomb, geologists in every country will add their sympathy. Those who knew him best have eulogised his love of truth, his piety, and his generous feeling for younger and struggling men of science.

The name of Elie de Beaumont is chiefly known out of France by its association with two theories—*Cratères de soulèvement* and the *Résau pentagonale*—which he espoused and vigorously defended, but neither of which has met with general acceptance, though no one can peruse the writings in which they are developed without admiring the wonderful industry of Elie de Beaumont in the accumulation of facts and the felicitous imagination with which he marshalled these facts in support of the theory to which he had pledged himself. It is not easy for geologists in other countries to understand the vast influence which for nearly half a century he has held in France. We must bear in mind the system of centralisation which controls even scientific enterprise in that country, and the fact that Elie de Beaumont held official posts in Paris which gave him a powerful sway over geological and mining matters, especially such as were under the guidance of the State. Hence it was not merely his great reputation, but his official position, which enabled him for so many years in great measure to control the progress of physical geology in his native country.

This eminent geologist was born in the year 1798. In 1817 he entered the Ecole Polytechnique, where he greatly distinguished himself, leaving it in the first rank for the Ecole des Mines. At that institution he showed a strong tendency towards geological pursuits, and such capacity for their prosecution that he was soon chosen to perform one of the most onerous tasks which had ever been undertaken by the Mining Department of France. The publication of Greenough's geological map of England, and the reception of a copy of it in the year 1822 at the Ecole des Mines, revived a project which political considerations had displaced, of constructing a geological map of France. When the decision to undertake this great work was formed, Elie de Beaumont, with his fellow-pupil and future friend and associate Dufrenoy, was selected to carry out the necessary surveys. With

the view of giving them still further training for their task, the authorities sent them over to study the geology of England, particularly the arrangement of the secondary rocks of this country, which by the genius of William Smith had become a type for all parts of Europe. Six months were spent in this preliminary work, some portion of the time being devoted to a careful study of British mines and mining, on which the two young engineers furnished some voluminous and skilful reports. It was the year 1825 before they received orders to begin their surveys. France was separated into two sections, the eastern half being allotted to Elie de Beaumont. The two observers, however, met frequently, and after the main part of their labours was concluded they went over portions of the ground together, so that in the end, agreeing on all main points, they produced a harmonious and magnificent work. In ten years they had completed their surveys. The engraving necessarily occupied some five years more, after which the indefatigable authors produced two large and exhaustive quarto volumes of explanations of the map, wherein the geological structure of their country was well described.

Of all the achievements of Elie de Beaumont, this, his first, is probably that on which his fame will ultimately most securely rest. It was a great work, most conscientiously and skilfully performed, amid difficulties which can only be adequately realised by those who have essayed geological mapping, and who know the nature of the ground over which the French explorer had to trace his lines.

During the twenty-three years (1825-48) which elapsed between the beginning and the completion of the map and its accompanying text, Elie de Beaumont had made his name widely known by other important contributions to science. A few years after the mapping had begun, and while engaged in exploring the high grounds in the east of France, he was struck by the relations which could be traced between the direction of different lines of mountain and the nature and position of the strata along these lines of elevation. In 1829 he published the first sketch of the theory which afterwards grew into the well-known *Résau pentagonale*. He likewise adopted and defended Von Buch's *Erhebungs-krater* theory, publishing in its support an elaborate essay on the structure of Etna (1836). One of his best essays was published in 1847, "Sur les Emanations Volcaniques et Métaallifères," a luminous exposition from the point of view of a cataclysmist of the history of the volcanic phenomena of the globe. One of his best separate publications is his "Leçons de Géologie pratique," a work full of knowledge and research, which may be usefully studied by all who take interest in dynamical geology. It would take some time to enumerate even the titles of his various contributions to the transactions and journals of his day. They include short notes and long memoirs of original research of his own, elaborate reports upon the writings of others (of this style he was a master), instructions to exploring expeditions, &c.; and they are not confined to physical geology, but embrace also the allied sciences—chemistry, mineralogy, and palæontology. One feature which characterises them is the endeavour after exactitude. Their author had a mathematical mind, and sought for mathematical precision in his development of a subject.

Elie de Beaumont in the course of his long career filled many offices of distinction. As far back as 1827 we find him lecturing for his master at the Ecole des Mines, and afterwards succeeding to the chair. In 1832, on the death of Cuvier, he was chosen to fill the only chair of Natural History at the Collège de France. He thus stood at the head of the geological tuition of the country. The mining engineers and others who required geological instruction for State certificates or appointments passed through his hands. His fame likewise attracted many from a distance, so that as a teacher his influence must be regarded as having been very great. Moreover, he became Inspector-General of Mines, member and perpetual secretary of the Academy of Sciences, and was an associate of many of the learned societies of Europe and America. His scientific renown and high personal character led to his being chosen as senator and raised to the rank of Grand-Officer of the Legion of Honour. Full of honours, therefore, he has closed a long life with his faculties unimpaired to the last, and in the midst of the activity which had marked his long and honourable career.

This is perhaps hardly the place or the time to pass any judgment on the work of the illustrious man who has just gone from among us. His name will ever be associated with the history of geology, linked with those of Cuvier, Brongniart, Dufrenoy, and others who led the way to all that has since been achieved in the geology of France.

ARCH. GEIKIE

#### FLÜCKIGER AND HANBURY'S "PHARMACOGRAPHIA"

*Pharmacographia: a History of the principal Drugs of Vegetable Origin met with in Great Britain and British India.* By Friedrich A. Flückiger, Ph.D., Professor in the University of Strassburg; and Daniel Hanbury, F.R.S., Fellow of the Linnean and Chemical Societies of London. (Macmillan and Co., 1874.)

THERE was a stir of anticipation and inquiry amongst pharmacologists when it first became known that Prof. Flückiger and Mr. Hanbury were engaged upon a work of joint authorship. Speculation was busy as to what was to be the nature of the book, to what particular objects it would be directed, what extent of ground it would cover, and so forth. Upon a single point all were agreed, namely, that it would *not* be one of those composite treatises on drugs—organic and inorganic—therapeutics, pharmacy, and toxicology, enlivened by traditional botany and old-fashioned chemistry, which have passed current amongst us as "Manuals of Materia Medica."

One generation after another of compilers have produced volumes supposed to be suited to the wants of the time, in which the same sort of information has been given, the same errors perpetuated often in almost identical words, until the very term "Materia Medica" has come to be looked upon with suspicion by scientific men. Perhaps the origin of the shortcomings of the general run of such works may be traced to the fact that they have often been written by practising physicians who were lecturers in medical schools, and have been designed primarily as handbooks for medical students. Nor need

it be a matter of wonder that, with no special facilities for acquiring original information as to the history of drugs, and with few opportunities for verifying the statements of others, authors so situated were content to transcribe without examination what had been already recorded as fact, and to devote their better energies to the more purely medical relations of the subject—the aspect of chief interest both to themselves and those for whom they wrote.

The question has often been raised, and once at least on very high authority, why the overcharged curriculum of medical study should still be encumbered with *Materia Medica*; why, in view of the separation which is gradually taking place between the practice of Medicine and that of Pharmacy and of the scientific education now received by the pharmacist, such matters as the physical characters sources, and chemistry of drugs should not be referred to those whom they primarily affect.

This, perhaps, is scarcely the place to discuss such questions in detail, but they inevitably present themselves on a comparison of the present book with any of those to which allusion has just been made.

It is generally no very difficult thing to give an intelligible account of a work embodying the results of scientific research. It is not requisite that the knowledge of the reviewer should be co-extensive with that of the author to enable him to form a just estimate of its strong and weak points, or even to exercise the critical faculty where opinions rather than facts are advanced. But the task of introducing suitably a closely printed volume of 700 pages, containing scarcely anything but facts—an unusual proportion of which are stated for the first time, and those which are old assuming a new importance from their fresh verification, the whole given with a condensation of style that refuses page-room to a superfluous word—is not one that can be performed by the ordinary method of summarising results.

The scope of the "Pharmacographia" and the intention of its authors can hardly be better told than by a few extracts from the Preface. After defining the word *Pharmacographia* as "a writing about drugs," the authors state that "it was their desire not only to write upon the general subject and to utilise the thoughts of others, but that the book which they had decided to produce together should contain observations that no one else has written down. It is in fact a record of personal researches on the principal drugs derived from the vegetable kingdom, together with such results of an important character as have been obtained by the numerous workers on *Materia Medica* in Europe and America."

Restricting the field of their inquiry by the exclusion of Pharmacy and Therapeutics, "the authors have been enabled to discuss with fuller detail many points of interest which are embraced in the special studies of the pharmacist."

"The drugs included in the work are chiefly those which are commonly kept in store by pharmacists, or are known in the drug and spice market of London. The work likewise contains a comparatively small number which belong to the *Pharmacopœia* of India: the appearance of this volume seemed to present a favourable opportunity for giving some more copious notice of the latter than has hitherto been attempted."

Now as to the manner of treatment. A uniform sub-

division into sections has been adopted throughout the work. In the first place, "Each drug is headed by the Latin name, followed by such few synonyms as may suffice for perfect identification, together in most cases with the English, French, and German designation.

"In the next section, the *Botanical Origin* of the substance is discussed, and the area of its growth or locality of its production is stated."

"Under the head of *History*, the authors have endeavoured to trace the introduction of each substance into medicine, and to bring forward other points in connection therewith, which have not hitherto been much noticed in any previous work."

"In some instances the *Formation, Secretion, or Method of Collection* of a drug has been next detailed: in others, the section *History* has been immediately followed by the *Description*, succeeded by one in which the more salient features of *Microscopic Structure* have been set forth."

The next division includes the important subject of *Chemical Composition*; then follows a section devoted to *Production and Commerce*; and lastly, observations, chiefly dictated by actual experience, on *Adulteration* and on the *Substitutes* which in the case of certain drugs are occasionally found in commerce, though scarcely to be regarded in the light of adulterants.

"The medicinal uses of each particular drug are only slightly mentioned, it being felt that the science of therapeutics lies within the province of the physician, and may be wisely relinquished to his care."

The reader must not judge the Preface by the disconnected sentences which have been quoted to serve a particular purpose. Only sufficient has been copied to explain briefly, and as far as possible in the authors' own terms, the general scheme of their work.

The plan, as will be seen, is one of great comprehensiveness, and the execution throughout is of characteristic thoroughness. A single article taken at random from the book would be better evidence than any criticism, of the exhaustive character of the treatment; but unfortunately, considerations of space preclude anything more than a few general remarks suggested by a first perusal.

The investigation of the botanical origin of drugs is one which Mr. Hanbury has made his own, and few writers have set at rest so many debated questions in this division of the subject. Completeness and accuracy of the information now collected is exactly what might have been expected. The student who knows only the British Pharmacopœia will find much to learn, and something to unlearn, concerning the origin of many common medicinal substances. In some cases the corrections necessary arise merely out of questions of priority in botanical nomenclature, but in others the errors are founded in the wrong identification of the plants. For instance, *Jacquinia palmata*, Miers, is the name accepted, for reasons given in the text, for the plant yielding calumba root, rather than the alternative specific terms of the Pharmacopœias. Oil of cajuput is assigned to *Melaleuca leucadendron*, L., whilst in the British Pharmacopœia and the Paris Codex it is referred to *M. minor*, DC., and in that of the United States to *M. cajuputi*, Roxb. Sumbul Root, the botanical history of which in our Pharmacopœia is stated to be unknown, appears as the product of *Euryangium Sumbul*, Kauffman, a plant of the natural

order Umbelliferae. On the other hand, in speaking of the botanical origin of Myrrh, which the Pharmacopœia, without show of doubt, assigns to *Balsamodendron myrrha*, Ehrenb., it is stated that "the botany of the myrrh trees is still encompassed with uncertainty, which will not be removed until the very localities in which the drug is collected shall have been well explored by a competent observer." It would be easy to multiply examples, but beyond a passing allusion to Pareira Brava as the root of *Chondodendron tomentosum*, Ruiz et Pav., a fact determined by Mr. Hanbury's researches, this portion of the subject need not be dwelt upon.

The information given under the head of "History" has a general as well as a technical value. All sorts of writers, ancient and modern, have been laid under tribute; and the glimpses one obtains, not only of the medical but of the domestic employment of drugs in past times, are full of interest.

This running commentary need not be extended to all the headings under which the treatment of each substance is arranged. The term "Substitute" as distinct from "Adulteration," perhaps needs a word of explanation. It is employed to comprise substances occasionally met with in commerce, the product of plants more or less closely allied to the official one; for instance, the wood of *Quassia amara* instead of that of *Picranea excelsa*, the occurrence of the root of *Aristolochia reticulata* in place of *A. serpentaria*, or of the dried plant of *Piper aduncum* in lieu of the true Matão.

The notices of Indian official drugs have the interest of novelty to European students, but beyond this leave little room for present remark. In course of time some of them may be introduced at home, and in any case, with the amount of communication which exists between England and her Eastern possessions, nothing which concerns the one can be unimportant to the other. Indian medical men are largely drawn from this country, and by them, at least, they will be gratefully received.

The only department of the book which does not yield unalloyed satisfaction is that which refers to "Microscopic Structure." The descriptive paragraphs are, no doubt, as good as words can make them, but mere words are insufficient for the purpose. If anyone doubts this, let him try to construct a drawing of microscopic structure from a description, and then compare it with the reality; or, on the other hand, let him endeavour to identify one vegetable production out of a number closely allied, by means of a mere verbal definition of characters. Either task is difficult at best, sometimes impossible. It is not to our credit that there should be no British work of reference containing a complete series of illustrations of the anatomy of drugs. What is wanted is not so much an elaborate atlas, like that of Dr. Berg, with large, ideal, diagrammatic drawings, suggested by the microscopic appearance of the various vegetable products used in medicine, as a set of figures of characteristic portions of structure presented in a form in which the working student may recognise them. How welcome such an addition to the book would have been from Prof. Flückiger's skilful hand. It is only just to the authors to state that they make no claim for completeness in this division of the work; indeed, they are so fully aware of what is needed, that one might almost indulge in the

hope of seeing a second edition with a supplementary volume of plates.

In a brief and imperfect notice like the present but scanty justice can be done to a book like the "Pharmacographia," a work which, from the amount of its original matter, the laborious verification of its facts, the accuracy of its references, and the extent of general erudition it reveals, will be received with no grudging welcome, and will be recognised at once and without misgiving as the standard of authority on the subjects of which it treats.

HENRY B. BRADY

#### SULLY'S "SENSATION AND INTUITION"

*Sensation and Intuition: Studies in Psychology and Aesthetics.* By James Sully, M.A. (Henry S. King and Co.)

A YOUNG aspirant to the woolsack had as part of his first examination the question, "To whom was the Declaration of Rights presented?" To refresh his memory he cast his eyes on the paper of the gentleman on his left, who had written William I.; willing to give himself every advantage, he next stole a glance at the paper of the gentleman on his right, where he saw William III. "Ah!" thought he, with a knowing twinkle of the eye, "I'll strike the happy medium"—and down went William II. Mr. Sully, in the first of this collection of interesting essays, has struck the happy medium between the evolution and the individual experience psychologies.

Mr. Sully has read and pondered all the learning of his subject; but the thoroughgoing evolutionist is not unlikely to accuse him of having done more than "shaded for a moment the intellectual eye from the dazzling light of the new idea." If, as we are told, "it is far from improbable that a fuller investigation of the processes by which our conceptions of *space* are built up, will render superfluous the supposition of their innateness," it is not at all probable that *any* other conceptions are inherited. And the evolutionist will not, we fear, be able to draw much comfort from the assurance that "the psychologist, when satisfied of the presence of distinct mental phenomena not traceable to the action of his own laws, will gratefully avail himself of the additional hypothesis supplied to him by the philosopher of evolution;" for it not unfrequently is very difficult indeed to satisfy the psychologist of the presence of anything not traceable to the operation of his own laws. An authority in psychology writing in "Chambers's Encyclopædia," says that the assertions with regard to the instinctive perceptions of distance and direction by the newly hatched chick are, "in the present state of our acquaintance with the laws of mind, wholly incredible." We now know that the chick has not the least respect for those laws of mind; and we have already in these columns (*NATURE*, vol. vii. p. 300) argued that we have no sufficiently accurate acquaintance with the alleged acquisitions of infancy to justify the doctrine that they are different in kind from the unfolding of the inherited instincts of the chicken. To what we then said Dr. Carpenter has replied on one point in his "Mental Physiology" (p. 179). While admitting that human beings require no education to enable them "to recognise the direction of any luminous object," he

maintains "that the acquirement of the power of visually guiding the muscular movements is *experiential* in the case of the human infant." In support of this somewhat inconsistent position, he gives facts within his own knowledge which we do not feel to be in the least inimical to the doctrine against which they are arrayed. Mr. Sully is more consistent; he thinks it proveable that the eye has no instinctive knowledge of either the distance or the direction of a visual object. He relies greatly on "Recent German Experiments with Sensation" (the subject of his third essay), which, like Dr. Carpenter's facts, appear to us in perfect harmony with the theory they are supposed to disprove. Without doubt, there is no higher scientific authority than Helmholtz, and just for this reason is it specially instructive to observe how readily even he accepts as statements of fact what never could have been more than the suggestions of theory. In the last of his admirable course of lectures on "The Recent Progress of the Theory of Vision," he says: "The young chicken very soon pecks at grains of corn, but it pecked while it was still in the shell, and when it hears the hen peck, it pecks again, at first seemingly at random. Then, when it has by chance hit upon a grain, 'it may, no doubt, learn to notice the field of vision which is at the moment presented to it.'" In this list of assertions, even the one that might seem most certainly true is a mistake. The chicken does not peck while still in the shell; though that it does so is, we believe, the universal opinion, the actual mode of self-delivery having never been observed. The movement is just the reverse of pecking. Instead of striking forward and downward (a movement impossible on the part of a bird packed in a shell with its head under its wing), it breaks its way out by vigorously jerking its head upward and backward, while it turns round within the shell. With the advance of knowledge, theories will have, though it may be reluctantly, to accommodate themselves to facts; and after the din of the battle is over, it will be found that the real facts had never had any difference among themselves.

Mr. Sully differs from Mr. Spencer as to the relation of the evolution hypothesis to the question of realism and idealism. He is aware that Mr. Spencer "distinctly affirms that the reality of an independent unknowable force is necessarily involved in his theory of evolutionary progress. But this," Mr. Sully observes, "can only mean that every distinct conception of subject and object involves this postulate; and this assumption can hardly fail to strike one as a *petitio principii*, inasmuch as able thinkers have undertaken to find the deepest significance of this antithesis in purely phenomenal distinctions." Perhaps Mr. Spencer might be able to produce instances in which the facts of the universe have turned out not exactly what able thinkers had undertaken to find them. Considerable strain is put by Mr. Sully on Mr. Mill's formidable definition of matter—that it is "a permanent possibility of sensation;" but we greatly fear that when brought to close quarters the idealist that puts his trust in this verbal monstrosity will find himself left in the lurch. Somehow through "processes of repeated experience and sharpened intellectual action, the mind comes," we are told, "to conceive a possible impression as the originating cause of a present one, and so to arrive at that vast stream of objective events which flows on beyond,

and independently of, the actual series of feelings making up its own individual life." To follow this from the idealist's point of view is quite beyond us. A belief in permanent possibilities of sensation that flow on independently of our feelings is in some danger of being mistaken for realism. Mr. Sully, however, is very sure that the realists are wrong; and as a psychologist he must be able, by aid of his science, to explain their error, just as an astronomer accounts for an eclipse. This is how our realistic philosophers go wrong. Under the influence of a refined sentiment of awe, they see what is not there. Not only does this emotion "lead the mind to anticipate the presence of insoluble mystery where a calmer intellectual vision sees only clear regularity; but it serves to support conceptions of an unknowable where the closest observation and most accurate reasoning fail to detect any signs of such an existence." The superstitious terror of the rustic transforms a white calf into a ghost; the awe of the philosopher sees a ghost where there is no calf.

In a very suggestive essay Mr. Sully handles the difficult subject of "Belief: its Varieties and its Conditions." He finds "the primitive germ of all belief, the earliest discoverable condition that precedes in its influence that of action, in the transition from a sensation to an idea." In thus attempting to understand how the state of mind called belief resembles, differs from, and is related to other states of consciousness, Mr. Sully is, we think, on the right track. He is, however, by no means free from the crude, popular notion, that belief and volition, considered as facts of consciousness, have some special causal connection with the bodily movements. Indeed, he thinks that Prof. Bain "has succeeded most completely in showing the will to be a secondary and composite state of mind, inferable from more rudimentary states," one of these so-called rudimentary states being spontaneous bodily movements, which occurring by "a coincidence purely accidental" along with states of consciousness, these unlike things get somehow stuck together by "an adhesive growth, through which the feeling can afterwards command the movement." We have repeatedly maintained that while on the one hand there are reasons which seem to compel the belief that on his physical side man is a machine whose movements can never escape by a hair's breadth from the inexorable rule of physical law, there is on the other hand no "better ground for the popular opinion that voluntary movements take their rise in feeling and are guided by intellect, than a superficial observer ignorant of the construction of the steam-engine might have for a belief that the movements of a locomotive take their rise in noise and are guided by smoke."\* That Prof. Huxley's bold advocacy of this view at the recent meeting of the British Association has not called out more angry criticism is surely a most hopeful sign of the times.

It is with regret that we must now take leave of this collection of essays, which we have read with pleasure and profit; and we hope that our mode of expressing our criticisms will not be misunderstood or supposed to indicate a want of appreciation. To touch on all the points we had marked for observation would more than double the length of this review. Especially do we regret not being able to say a few words about "The Æsthetic

Aspects of Character." If Mr. Sully could admit that conduct cannot be beautiful in so far as it involves struggle, mental effort, for example, in so far as it is moral or virtuous on the subjective side, very little would then stand between him and one commanding generalisation.

DOUGLAS A. SPALDING

## LETTERS TO THE EDITOR

[The Editor does not hold himself responsible for opinions expressed by his correspondents. Neither can he undertake to return, or to correspond with the writers of, rejected manuscripts. No notice is taken of anonymous communications.]

### Sounding and Sensitive Flames\*

#### II.

ANOTHER example of a highly sensitive flame was recently described to me which seems to show that air-currents flowing through gauze at a proper speed are sensitive without the intervention or simultaneous superaddition of a flame. A special kind of Bunsen burner was made with a spiral mixing tube coiled in an inverted cup, at the centre of which is a small chamber covered with wire-gauze at the foot of a short tube or flame-pipe. The gas is admitted by a single jet passing through a cap of wire-gauze covering the conical opening of the spiral tube, the object of this cap of gauze being to distribute the air in its approach, and to protect the gas-jet from ignition. The gas-flame burns with a small bright green cone, surmounted by a larger envelope of pale reddish flame, and it is intensely hot. The green cone indicates combustion of the most complete explosive mixture of air and coal-gas, and when the burner is properly adjusted it can only burn on the top of the flame-tube, where it finds the additional required supply of oxygen; but it descends to the wire-gauze at the foot of the tube if the air-supply exceeds, or the gas supply falls short of the right proportion. In some of these burners the slightest noise of the kind that commonly affects sensitive flames causes the cone of green flame to retreat into the tube and settle on the wire-gauze at its foot, whence it rises again immediately to the top of the tube, when the sound ceases. The explanation seems to be that the air-current entering the mixing-tubes through the outer gauze cap is in a sensitive condition, and that when thrown into disturbance by the external sounds, it is more quickly seized and is drawn into the mixing-tube more rapidly by the gas-jet than when it is flowing over the jet in a tranquil state. The inventor of these burners, Mr. Wallace, assures me that some of them exhibit the most sensitive of sensitive flames, and that he has more than once thought of sending one of them as a most singularly effective illustration of such flames to Prof. Tyndall.

The explanation here given of the sensitiveness of Wallace's Bunsen-flame appears to be in great part correct; but the behaviour of the flame, which by Mr. Wallace's kindness I have seen since the above was written, differs considerably from that described; and some experiments connected with it lead me to modify to some extent the foregoing theory of the origin of sensitiveness in wire-gauze flames, and even, apparently, to except the gauze itself from any considerable share of mechanical action in the process. The gas in this burner is first turned low, until the green cone at the centre nearly disappears, and merges into the outer border of the flame from less effective mixture of air with the gas at a low speed of the jet. The flame is now sensitive to the smallest sound, mounting fully one-half higher at every word, or even syllable of a speaker, and at the stroke of a bell, or other acute sound, reaching about twice its ordinary height. It undergoes at the same time no change in its appearance, showing that the contents of the mixing-tube and chamber are merely urged out of the flame-tube with greater speed by some forward impulse of the jet behind. If the sound is continued, as by constantly ringing a bell, the expanded flame gradually subsides, from the expulsion of all the inferior gas-mixture in the burner, reaches its first stature, and passes into a condition of more concentrated combustion corresponding to a fuller, and therefore more rapid admission of gas to the jet; when the sound ceases, the contracted flame gradually recovers its first size and diffuseness from the same cause, namely, the expulsion of all the well-aerated gas

\* NATURE, vol. ix, p. 179: "The Relation of Body and Mind."

\* Continued from p. 6.

in the burner by an inferior mixture which succeeds it at a slower speed.

From the following experiment and considerations I am inclined to attribute the observed action of the disturbed flame almost entirely to direct influence of the sound upon the gas-jet, rather than to its effect upon the current of air passing through the conical cap of gauze that surrounds it. The current through the gauze is so slight that ascending smoke, slowly creeping round it, is not visibly drawn into its meshes. The sensitive action of the flame remains equally perfect when all but a very small aperture of the gauze is closely covered with thin sheet india-rubber. To determine if a naked jet, unsurrounded by wire-gauze, would by itself produce a flame so sensitive, I easily obtained with a Ladd's tapering brass jet a flame of this description. Laying it upon its side with its point inclining downwards, and inserting this into a brass tube about  $\frac{1}{2}$  in. wide and 15 in. long, also inclined, the flame at the lower end of this tube, when full gas was used, resembled a Bunsen-flame; but if the gas-supply is lowered, it becomes luminous; and at the lowest point at which it will continue to burn, the slight current in the tube appears to consist only of nearly pure coal-gas, and is of course (a useful point in the manipulation) quite inexplorable. A stamp, a cough, or other deep-pitched sound, as the exclamations Oh! and Ah! caused this flame to emerge from its hiding-place in the end of the tube into which it had retreated, and to rise in a tall tongue of light. It was not sensitive to notes of high pitch, to a hiss, nor to some of the acuter vowel-sounds of the voice, unless very strongly uttered; but a short gong or groll called it forth at once. The lower the speed of a jet the slower, possibly, may be the vibrations required to affect and sensibly to disturb its equilibrium. With a very perfect gas-meter the question might also be decided how much of the large additional gas-volume in the flame which occasionally reached a height of about 2 in., and which could easily be maintained permanently at a height of about 1 in. by continued stamping on a stone floor, is derived from the gas-jet itself, and how much from increased admixture with it of the surrounding air. As the jet is constantly being bent, as it leaves the fixed nozzle, into the shape of a corkscrew, or of some other wave-curve by the air-vibrations, it probably draws more air along with it, in the same way that a coarsely twisted rope in hair-rope pumps raises more water than a smooth belt or a perfectly smooth and straight rope would do. Something of this kind, perhaps, may be supposed to take place; and contrary to the opinion which I at first entertained, above, of the cause of the sensitiveness at low gas-pressures of Barry's sensitive wire-gauze flame, it seems more probable that the flurry and depression of the flame produced by external sounds is the result of their action upon the gas-jet below, mixing the gas more thoroughly with air, and giving it explosive properties before it passes through the gauze. The gauze-flame must be regulated by lowering the gas-jet, until the brink of its stability and tendency to collapse and burn noisily on the gauze is nearly reached, in order to make this destruction of its equilibrium by external noises possible; and the explanation thus offered of the sensitiveness of the gauze-flame at lower gas-pressures than those used with other flames depends upon no assumption of mechanical actions of unusual delicacy, or indeed of any peculiar kinds of undulation taking place among the perforations of the gauze.

I have quite recently seen an instrument connected very closely with the acoustical properties of flames burning on wire-gauze, showing how well instrument-makers have appreciated them, and how actively they are engaged in representing them in a convenient form. It resembles Geyer's sounding modification of Barry's sensitive flame so nearly, that but for its having received no such title from the maker, the source of its original invention might scarcely be considered doubtful; but it appears more probable, as will be seen from a description in NATURE (to be shortly again referred to) by Dr. A. K. Irvine (vol. x. p. 273), of Glasgow, of identically the same instrument patented many years ago for a very different purpose, that the designer of this singing tube may also have been guided by a knowledge of that invention. Even allowing for the general knowledge of the acoustical properties of wire-gauze flames that has for a long time existed, the instrument shows signs of originality of design that cannot easily be accounted for without some such consideration. It consists of a brass stand with two sliding brackets, one of which supports, in a split cork, a glass tube tapered above to a point to mix a jet of gas with air. The other arm supports a brass tube five-and-a-half inches high, and about an inch and three-quarters wide, closed at the bottom with a disc of

gauze held there against a fixed rim in the tube by a wire ring. The position of the gauze close to the bottom of the tube and that of the tapering gas-jet under it, as well as the dimensions of the tube, are the counter-part of Mr. Geyer's experiments with Barry's sensitive flame, only differing in want of adjustability of the relative positions of the tube and diaphragm of wire-gauze from his arrangement. The arrangement itself is, however, on the other hand, exactly that which Mr. Irvine patented, as will soon be seen, twelve years ago, for use in a new description of miner's safety lamp. The sound produced, when the flame is lighted on the wire-gauze inside the tube and the jet below it is fixed at a proper height, is, as might be anticipated from its high pitch, answering to the short length of the open tube, an excruciatingly piercing note.

I was not aware that the effect of heat alone in gauze-diaphragms to produce musical sounds in open tubes had been observed and investigated, as it is stated to have been by Prof. Barrett, so thoroughly by Prof. Kijke, of Leyden; and a perusal of that author's description of his experiments, and of his comments upon them, would undoubtedly be of exceeding interest. That the experiment has often been repeated since, and has been varied in many ways by those who were acquainted with it, is a consequence that I was fully prepared to learn, from its great beauty, would follow very speedily upon the first publication of its discovery.

I have never examined sounding and sensitive flames with revolving mirrors; but the result could scarcely fail to prove very instructive. The indications of his own essays in pursuit of this method contained in Prof. Barrett's letter, both where I have been able to consult the original writings and drawings that he quotes, and where he offers us a short account of further results apparently more noticeable than those obtained before, of the appearance of a particularly active and impressionable sensitive flame affected by the vowel sounds, when viewed in a moving mirror, show that the characteristic comportment of these flames is eminently adapted for examination and discussion by such a mode of observation.

Similar experiments on the chirruping, whistling, trumpeting, and other sounding open flames, obtained by the collision of two jets, examined by Prof. Tyndall and Mr. Cottrell, here suggest themselves; but I must listen to bring this long excursive letter to a close. I cannot, however, do so without expressing my obligation to Prof. Barrett for the valuable references and information that he has been good enough to supply, and for the prompt and ingenious manner in which he kindly rectified my oblivious association of his name with Mr. Barry's in certain recent observations of the sensitiveness of wire-gauze flames. The notices contained in a short space in his most interesting letter gave me a better acquaintance with the progress of this wide and curious subject, than repeated and anxious inquiries concerning it for several months previously in the scattered pages of many recent scientific journals had enabled me to acquire.

I must also add my acknowledgments to Mr. T. S. Wright and to Mr. A. K. Irvine for the interesting notes that they have furnished in NATURE (vol. x. p. 273, and p. 286) on the early use of wire-gauze flames to produce vociferously loud sounds in open tubes. That large iron tubes specially fitted inside with gauze-covered (or the so-called "smokeless") gas burners, to produce a mighty sound, should be preserved as working instruments of a chemical laboratory in Edinburgh as long ago as the year 1842; and that as much as twelve years since a kind of safety-lamp for mines was patented by Mr. Irvine in this and other countries, sounding a loud alarm note when the lamp-flame lights the explosive mixture of fire-damp entering the bottom of the wick-tube through a wire-gauze disc placed there to cover it, are facts that need no comments to show that the surpassing power of such flames to excite and sustain musical sounds has long been known and used successfully. The excellent character and performance of the instruments used in 1842, as described by Mr. Wright, makes it probable that frequent illustrations of the same kind must already have preceded them. On the other hand, from the well-known scientific eminence of their possessor, Dr. David Boswell Reid, as a skillful director of large works of ventilation, it may also be presumed that they probably presented to his views novelty of some special kind, either of invention or of construction, or of both combined, the result of which was the production of several such superior instruments. It may not be impossible from this consideration, at least if no evidence of considerably earlier origin could be produced, to fix the time, and perhaps the authorship by Dr. Reid himself, or by his brother the chemist, Dr. William Reid of



Edinburgh, in whose laboratory Mr. Wright practised with them, of the first use of smokeless coal-gas flames in acoustical experiments as not long anterior to the date named by Mr. Wright as that of his practical experience of their use. But it might as be borne in mind that of all highly inflammable and intensely heating gases next to hydrogen, the most easily procurable since the general extension of the use of coal-gas, is an explosive mixture of the latter gas with air; and the experiments of Sir H. Davy, in 1816, having demonstrated that such a mixture may be prepared safely underneath wire-gauze and may be safely burned above it, the use of the wire-gauze flame for laboratory heating purposes, and also to illustrate very suitably the chemical harmonicon, must have been a very early suggestion. Its unwieldy size and stentorian proportions for the latter purpose, however, have not impossibly led to its comparative abandonment and

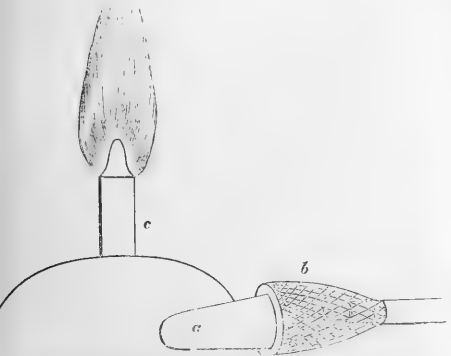

J. WALLACE'S TABLE BUNSEN-BURNER.

a.—Conical and spiral mixing-tube coiled inside the foot, terminating at the centre in a small chamber closed with wire-gauze at the top, at the foot of the flame-tube. b.—Conical wire-gauze cap, strengthened by three wires to support the gas-tube, to protect the gas from ignition, to keep off draughts, and to distribute the current of air to the gas (junctions all soldered). c.—Short flame-tube, closed at the bottom with wire-gauze to prevent the flame from flashing back when the gas is turned on or off. Whole height about 2½ in. Height of flame, 1½ in. or 2 in. Height of central bright flame, exactly ½ in.

disappearance from the scene of modern laboratory experiments, and to its general replacement, in coal-gas illustrations of the chemical harmonicon, by various modifications with different forms of jets, of the much more portable, convenient, and easily adaptable Bunsen-burner. Thus a long-recognised and important application of gauze-topped gas-burners in the student's scientific practice might have fallen into oblivion, or into disuse and comparative neglect, if contemporaneous experiments like those of Irvine, Barry, Govi, Geyer, Rijke, and it may safely be prophesied of many other active fellow-workers in the same field of discovery and research, did not revive the discussion, and continue to develop the observation of these flames with multiplied results that appear to be in perfect accordance with the principles, and to furnish the most beautifully effective illustrations possible of important properties of effluent gas-currents, which would perhaps otherwise escape detection. The laws of the flow of escaping gas-jets, their powers of producing ventilation and exhaustion, and, on the other hand, the means of providing for their escape with as little waste of their energy as possible, are questions of practical importance in so many useful industrial applications, that they amply deserve the increased measure of scientific attention which the beautiful succession of modern discoveries of sensitive and sounding flames has been very materially instrumental in attracting, and appears still further to be eminently capable of directing towards them.

Newcastle-on-Tyne, Oct. 19

A. S. HERSCHEL

#### Insects and Colour in Flowers

In his second letter (NATURE, vol. xi. p. 28) Mr. Mott passes to the discussion of the general question whether beauty is an "object in nature." On that point my feeling is that our know-

ledge is as yet far too limited for us to presume to declare with any confidence what is an object in nature. Still less should we venture to assert what is *not* an object, and least of all have we any right to affirm that beauty is not an object, when we see developed, beauty of form, of colour, of sculpture and marking, so constantly throughout the organic world, and by such a great variety of means. Sometimes beauty of colour undoubtedly exists when, so far as we can see, it confers no benefit whatever on its possessor. Mr. Darwin instances arterial blood and the autumnal tints of leaves. More frequently it is accompanied by some advantage, direct or indirect; and the question is whether in such cases it has been acquired through the operation of sexual or natural selection, more particularly whether in the case of flowers the selection has been effected through the agency of insects, which have favoured the most conspicuously coloured. It remains with Mr. Mott to show in what way the facts detailed in his original letter (I hope he will pardon me for taking him back to it) fail to harmonise with that doctrine. To my mind the fact that a cultivator, by carrying out a like selection, propagating from plants which bear the largest and brightest, double or showy sterile flowers, can produce like results, supports and corroborates the doctrine rather than militates against it. Nor can I see anything discordant in the fact that the colour of fruits has been acquired through the medium of an entirely different selecting agent.

One circumstance appears to me to present some difficulty; and, although it is in no way connected with Mr. Mott's letter, I should like to mention it in the hope that others may be able to supply a satisfactory explanation: it is the case of flowers that are coloured on the outside, but white within. Where such flowers from their position or form present to view principally their exterior, as *Tulipa edisiana*, this is an adaptation that can be readily understood; but some display mostly their interior, and it is then difficult to understand the acquirement of colour outside only. I would instance *Smilax bicolor*, *Gypsophila cretica*, *Daphne jasminea*, and several species of white-rayed Compositæ. *Ballistastrum michxlii*, for example, has frequently the inner surface of the ray florets quite white, and when the flower is open nothing else is seen; the colour on their outer surface only becomes visible when they close over the disc, as in dull and rainy weather.

Newton-le-Willows, Nov. 16

THOMAS COMBER

WITH reference to this question, is cross-fertilisation so desirable for the plant as is stated?

In this country, and I believe as a rule elsewhere, brilliant flowers are produced by shrubs, climbing and herbaceous plants, while the inflorescence of trees is comparatively inconspicuous. Does it not seem probable that beauty of colour is gained at the expense of strength, majesty, and longevity?

J. S. H.

#### Drosære

I FIND that during my absence from England many applications have been made for plants of the Drosære and Pinguiculae, and from the replies which have been sent on receipt of the plants they seem to have given satisfaction. Lately, however, in consequence of the weather, there has been some difficulty in obtaining *D. intermedia*, but before this is printed in your columns, all existing applications will be cleared off.

I wish to add, that in winter these plants can scarcely be expected to be as active as in spring and summer, and observers must wait patiently until spring before they may hope to obtain successful results from their observations: it cannot be necessary, I think, to feed carnivorous plants artificially during the winter; and a hot-house or conservatory cannot be absolutely necessary, as they have no such advantages in their native wilds.

G. H. HOPKINS

#### Suicide of Scorpions

THAT scorpions do commit suicide, as described by your correspondent last week, is a well-known fact. My grandfather often related how he had seen these creatures, when surrounded by a circle of glowing embers, make for the inner side of their fiery prison, then deliberately move round the inside of the circle, and when arrived at the exact spot from which they started, turn back their tails and sting themselves to death.

Clyde Wharf, Nov. 16

M. L.

### The Cry of the Common Frog

IN NATURE, vol. x. p. 461, Mr. Mott notices the cry of the common frog when annoyed. One of the greatest enemies of this frog in the United States is the common striped snake (*Tropidonotus tenia*, Dekay). He seizes the frog by the hind legs for the purpose of swallowing him, when the latter will utter a most pitiful cry. I have detected them in this condition at a distance by the frog's note. I have amused myself by taking a frog by the hind legs and dragging him slowly backwards on the ground in a serpentine direction, when he will exhibit his characteristic wail to perfection; and, when released, he will frequently utter some apparently intelligent imprecations as he hops off out of reach. I have noticed the same effect produced by a playful kitten amusing itself by teasing the frog, seemingly for the purpose of hearing him cry. Sliding a stick after him like a snake will produce the same results in a still more striking manner. A. T. T.

Oswego, U.S., Oct. 29

### Phylloxera Vastatrix

CAN any of your readers kindly inform me where a specimen of *Phylloxera vastatrix* can be obtained?  
Ipswich

A. HARWOOD

### A Nest of Young Fish

WHILE on the point of taking my accustomed morning plunge in one of the clear pebbly streams that find their way into the plains from the northern mountain ranges of the island of Trinidad, my attention was attracted by the eccentric movements of a small fish of the perch tribe. In general this fish is extremely shy, scudding off into deep water or under some overhanging bank on the approach of man; on this occasion, however, on putting my hand into the water, the fish, to my astonishment, darted forward again and again, striking my hand with considerable force. Rather at a loss to account for such temerity in a fish only 4 in. long, I watched its movements narrowly, and at last found out the cause. In a small hollow close by, about the size of half an egg, artistically excavated from the bright quartz sand, a multitude of tiny fish were huddled together, their minute fins and tails in constant motion. They had apparently been only very recently hatched, and were no larger than common house flies; the parent fish kept jealous watch over her progeny, resenting any attempt on my part to touch them.

Next morning, accompanied by my father and brothers, I returned to the spot which I had carefully marked the day before. For some time, however, we searched in vain for the fish and her young; at length, a few yards further up stream, we discovered the parent guarding her fry with zealous care in a cavity similarly scooped out of the coarse sand; any attempt to introduce one's finger into the hollow was vigorously opposed by the watchful mother. This is the first and only instance that has come under my notice of a fish watching over her young, and conveying them, when threatened by danger, to some other place. The clear streams that flow along the valleys among the northern mountain ranges of the island abound with fish of the variety I refer to; they are in general of a bright yellowish brown, with two or more silvery stripes on the sides, and seldom exceed five inches in length; but in the sluggish turbid rivers of the plains, the bright colours change to a dull brown; the fish are larger, however, varying in size from eight to ten inches. Extremely tenacious of life, these fish, in common with several other species, have the power of existing in a semi-torpid state for weeks, and even months, buried during severe droughts in the mud of dry watercourses, where they are dug up by the Creole peasants, who prize them as food; but from the peculiar earthy flavour common to many varieties of freshwater fish frequenting the muddy rivers of the low lands, they are not relished by the more fastidious palate of the European.

ROBERT W. S. MITCHELL

### THE DEVELOPMENT OF MOLLUSCA

MR. RAY LANKESTER, in the current number of the *Quarterly Journal of Microscopical Science*, gives the results of his examination of the embryo of the

common Pond Snail (*Limnaeus stagnalis*). These are of great importance; first, because they show how much may be done by trained observation, with improved methods, of a very common form, which has already been studied by excellent anatomists; and secondly, because Mr. Lankester's previous investigations into the development of cuttles, *Pisidium*, and several marine gastropods, enable him to form a sound judgment of the bearing of his discoveries upon questions of homology and of classification.

In *Limnaeus*, Mr. Lankester finds that the process of segmentation (which is well illustrated by drawings of the egg in various positions at the several stages) is followed by the formation of a gastrula through a process of invagination. This gastrula (for Mr. Lankester adopts this term from Prof. Haeckel instead of "planula," the one he himself invented), with its double layer of cells and single orifice, develops into the next stage by the mouth closing and afterwards giving rise to the anus, while a fresh oral opening appears and a velum is developed. The presence of a velum in pulmonate Gastropoda has not, we believe, been previously established, and is of great morphological importance. It is, Mr. Lankester believes, homologous with the trochal disc of rotifers, and he proposes the term "veliger" for the phase of development in which it appears. Nay, he gives reasons for regarding the subtentacular lobes of the adult *Limnaeus* as a residue of the velum. If it be so, it is the only instance yet known of this embryonic structure persisting in the perfect form.

The "anal cone" of M. Lereboullet is shown to have nothing to do with the anus, which is developed in the pedicle left by the obliterated gastrula-mouth. The functional import of the "anal-cone," or rather gland-sac, is still obscure. It has been already recognised by Mr. Lankester in *Pisidium*, *Aplysia*, and *Nereida*, and by Hermann Fol in embryo Pteropoda. It is possibly homologous with the basal gland described by Kieferstein and Kowalevsky in *Loxosoma* among Bryozoa, and with a similar structure in *Terebratula*. The more difficult questions of its homogeneity with the rudimentary internal shell of the slug, and with the penac of cuttles, are also discussed. One of the most curious facts about this "shell-gland" is that it frequently becomes filled with a homogeneous refracting secretion apparently chitinous in composition, which is a morbid, or at least an abnormal change, and associated with irregular development of the embryo.

Not the least valuable point established in this interesting memoir is that the rotation of the embryo *Limnaeus* is caused by numerous short cilia on the annular band which afterwards forms the velum. The discovery of these cilia, which were sought by Lereboullet without success, is probably due to Mr. Lankester having used perosmic acid, a reagent which is exceedingly useful in examining transparent Tunicata, and seems equally suited for displaying cilia anywhere.

The gastrula form appears apparently in all groups of animals but the highest and the lowest, in some form or other; but the "shell-gland" forms a valuable additional link between the Brachiopoda and Polyzoa on the one hand and the higher Molluscs on the other. If this be admitted, it is probable that Tunicata may be again admitted to the same great stem in spite of their undoubted affinities to vertebrates by *Amphioxys*, and to worms by *Balanoglossus*.

It is a most satisfactory sign of the revival of embryology in England, that in the same number of the *Quarterly Microscopical Journal* which contains this important memoir by Mr. Lankester, there is also the preliminary account of the development of Elasmobranchii, by Mr. Balfour, which excited so much interest at the late meeting of the British Association.

## ON MIRAGE\*

THE name of "Mirage" is applied to certain illusory appearances due to excessive bending of the rays of light in their passage through the atmosphere. These appearances are by no means uniform.

Sometimes, especially in hot countries, the observer loses sight of the ground beyond a certain distance from his position, and sees in its stead, what looks like a sheet of water, either calm or with movements resembling waves; and if any distant objects are sufficiently lofty to be seen above this apparent lake, their images are seen beneath the objects themselves, inverted as if by reflection in this imaginary water. The dry and hot soil of Egypt is famous for the production of this form of the phenomenon. It is also mentioned as of frequent occurrence in the plains of Hungary, in the plain of La Crau in the South of France, and in the fen districts of England when dried up by the summer heat. It is also common in Australia. The Deputy Surveyor-General of South Australia once reported the existence of a large inland lake, which on further examination turned out to be nothing but a mirage.

Another class of appearances are known (especially among nautical men) under the name of *looming*. Distant objects are said to loom when they appear abnormally elevated above their true positions. This abnormal elevation not unfrequently brings into view objects which in ordinary circumstances are beyond the horizon. It is also frequently accompanied by an appearance of abnormal proximity (though this may perhaps be rather a subjective inference from the unusual elevation and clear visibility of the objects than a separate optical characteristic), and it is further accompanied in many, though not in all cases, by a vertical magnification, the heights of objects being many times magnified in comparison with their horizontal breadths, so as to produce an appearance resembling spires, pinnacles, columns, or basaltic cliffs. Some beautiful descriptions of these latter appearances, with illustrative plates, are given in Scoresby's "Greenland," the objects thus magnified being icebergs; and a very full and interesting account of the phenomena of mirage, as observed in high latitudes, will also be found in the "Arctic Regions" of the same author.

It is usually across water that looming is observed; and as a surface of water stands naturally in contrast with a sandy desert or a surface of parched land, so also the optical effects produced are, in a manner, opposite. The inverted images which are often presented in looming are not beneath the object, as in the case of mirage on dry land, but above it, as is formed by reflection in the sky. The only examples that I have myself seen of mirage were of this kind. They were seen across sheets of calm water, the hills on the other side being seen with fictitious hills upside down resting on the tops of the real hills. In rare instances, two or even three of these images are seen one above another, vertically over the real object; but these multiple images are usually too small to be seen without the aid of a telescope—the objects whose images they are being so distant as to appear mere specks to the naked eye.

There is always more or less of change observable in the images formed by mirage, and the changes are greatest and most sudden when the images are most distorted, as compared with the true forms of the objects. The appearances also change with the height of the observer's eye. Looming is seen to the greatest advantage from an elevated position, such as the mast-head of a ship. The mirage of dry land is sometimes visible at any moderate height, but in other cases—especially in countries which are not very hot—the range of height from which it is visible is extremely limited. A very fine mirage, recently observed in the fen districts, was only

seen when the observer was on the top of the marsh wall. But this case seems to have been peculiar. It was accompanied by the further peculiarity that a strong wind was blowing—the general rule being that mirage is only seen in calm weather. Observers of mirage on the sands of Morecambe Bay, and of the Devonshire coast, state that it could frequently be only seen by stooping.

Mirage is seldom seen in winter. The hot shining of the sun seems to be an invariable antecedent; and this is true even of the polar regions, where Capt. Scoresby attributes the phenomenon to "the rapid evaporation which takes place in a hot sun from the surface of the sea, and the unequal density occasioned by partial condensations, when the moist air becomes chilled by passing over considerable surfaces of ice."

Time will not allow me to do much in the way of quoting the very numerous records which exist. Scoresby's accounts alone would almost suffice to occupy the evening, and I would again refer to them as models of accurate observation and effective description. I will content myself with quoting nearly in full the account of a mirage observed at Hastings and neighbouring parts of the south coast of England in 1798, as given in the Philosophical Transactions for that year, the narrator being Mr. Latham, F.R.S. :—

"On Wednesday last, July 26, about five o'clock in the afternoon, whilst I was sitting in my dining-room at this place (Hastings), which is situated upon the parade, close to the sea-shore, nearly fronting the south, my attention was excited by a great number of people running down to the sea-side. Upon inquiring the reason, I was informed that the coast of France was plainly to be distinguished with the naked eye. I immediately went down to the shore, and was surprised to find that, even without the assistance of a telescope, I could very plainly see the cliffs on the opposite coast, which at the nearest part are between forty and fifty miles distant, and are not to be discerned from that low situation by the aid of the best glasses. They appeared to be only a few miles off, and seemed to extend for some leagues along the coast. I pursued my walk along the shore to the eastward, close to the water's edge, conversing with the sailors and fishermen on the subject. They at first could not be persuaded of the reality of the appearance, but they soon became so thoroughly convinced, by the cliffs gradually appearing more elevated and approaching nearer, as it were, that they pointed out and named to me the different places they had been accustomed to visit, such as the Bay, the Old Head or Man, the Windmill, &c., at Boulogne, St. Valéry, and other places on the coast of Picardy, which they afterwards confirmed when they viewed them through their telescopes. Their observations were, that the places appeared as near as if they were sailing at a small distance into the harbours.

"Having indulged my curiosity upon the shore for near an hour, during which the cliffs appeared to be at some times more bright and near, at others more faint, and at a greater distance, but never out of sight, I went upon the eastern cliff, which is of a very considerable height, when a most beautiful scene presented itself to my view; for I could at once see Dungeness, Dover cliffs, and the French coast, all along from Calais, Boulogne, &c., to St. Valéry, and, as some of the fishermen affirmed, as far to the westward as Dieppe. By the telescope, the French fishing-boats were plainly to be seen at anchor; and the different colours of the land upon the heights, together with the buildings, were perfectly discernible. This curious phenomenon continued in the highest splendour till past eight o'clock, . . . when it gradually vanished. The day was extremely hot, . . . not a breath of wind was stirring the whole of the day. . . . A few days afterwards I was at Winchelsea, and at several places along the coast, where I was informed the above phenomenon had been easily visible.

\* A Paper read by Prof. J. D. Everett, M.A., D.C.L., before the Belfast Natural History and Philosophical Society.

"I should also have observed that when I was upon the eastern hill, the cape of land called Dungeness, which extends nearly two miles into the sea, and is about sixteen miles distant from Hastings, in a right line, appeared as if quite close to it, as did the fishing-boats and other vessels which were sailing between the two places. They were likewise magnified to a great degree."

I have stated that the phenomena which constitute mirage are due to the bending of rays of light in the atmosphere, and I now proceed to point out the principles by which this bending is governed.

dense all round it, it is deflected towards the side on which the density is greatest; and that the sharpness of the curvature, as measured by the change of direction for a given length of the ray, is directly proportional to the rate at which the density varies along the normal. Strictly speaking, I ought, instead of "density," to have said "absolute index of refraction, diminished by unity;" but experiment has shown that the difference between these two statements, when there is no substance in question except air and aqueous vapour, is quite insignificant.

Supposing the stratification of the air to be strictly horizontal, it follows that a ray travelling vertically will not be bent at all, since there is no variation of density in the direction of its normal; and of all rays which traverse the same point, those which are horizontal will be bent the most, because the whole change of density is normal to them, and has a direct tendency to bend them downwards. For rays which are nearly horizontal, the curvature will be very nearly the same; and, as it is by such rays that we see the images which constitute mirage, the maximum bending of atmospheric rays is available for the explanation of the phenomena. In the average state of the atmosphere, the curvature of rays which are horizontal, or nearly so, is about one-fifth or one-sixth of the curvature of the earth's surface; though it is to be remarked, by way of caution, that the connection between these two curvatures is merely accidental; the curvature of the earth is not the cause, nor even a partial cause, of the curvature of rays.

Other things being equal, the curvature of rays should be greater in cold than in warm air, and greater with high than with low barometer; but these are not the principal modifying elements. The circumstance which it is most important to know, at any time, in order to predict the degree of curvature, is the rate at which the temperature changes with the height. The average change is a fall of about  $\frac{1}{300}$  of a degree Fahr. per foot of ascent. A fall of one fifty-third of a degree per foot of ascent would make the air equally dense at all heights, and would cause rays to travel in absolutely straight lines. A more rapid fall than this would render the air aloft denser than that below, and would cause rays to bend up instead of down. The existence of denser, and therefore heavier air aloft, is obviously incompatible with stability of equilibrium;

but unstable equilibrium may endure for a time, even under statical conditions; and when there is a powerful cause at work, tending to raise the temperature of the lower strata, it is quite conceivable that the lower air may be heated faster than it can get away (if I may be allowed a somewhat loose expression); so that, although there is a perpetual diffusion going on, the heated air ascending, and cooler air from above taking its place, there is, nevertheless, a difference of temperature perpetually maintained, exceeding one-fiftieth of a degree per foot. The circumstances under which the Egyptian form of mirage is observed are precisely such as are fitted to produce this state of things. A fierce sun scorching the parched

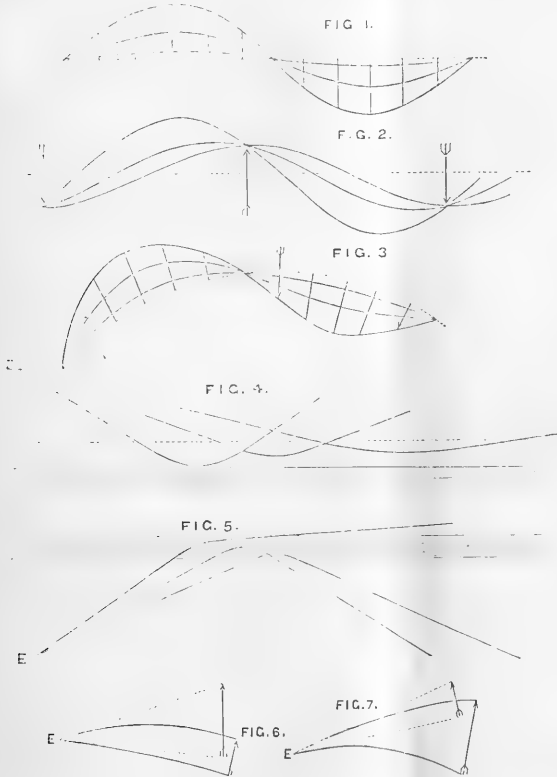

PLATE I.

My esteemed colleague, Dr. James Thomson, has greatly contributed to the clearness of our knowledge, as regards the disturbing effect of the atmosphere upon the direction of a ray of light. He has recently published an investigation,\* which, to say the least, is simpler and more satisfactory than any before given, of the precise law which determines the curved path of a ray through the air.

Referring you for the details to the last chapter but one of my own recently published edition of Deschanel's "Natural Philosophy," I will merely say that when a ray is passing through a portion of air which is not equally

\* British Association Report, 1872, p. 41.

ground, while the air is excessively transparent to his rays—flatness of surface, eminently conducive to the maintenance of unstable equilibrium—and absence of wind—such are the conditions under which this form of mirage appears. On the other hand, if the decrease of temperature upwards is slower than usual, the ordinary downward bending of rays will be increased, and if any physical cause, such as warm winds commencing aloft, before they are felt at the earth's surface, produces a reversal of the ordinary distribution of temperature, so that there is an *increase* upwards, instead of a decrease, this change will favour the downward bending of rays, which will, accordingly, be exaggerated; for the lower air, being not only under greater pressure, but being also colder than the upper air, will for a double reason be denser.

Capt. Scoresby states that "the curious refractions of the atmosphere in the polar regions are most frequent on the commencement or approach of easterly winds," and he elsewhere states that easterly and southerly winds are mild.

An increase of temperature upwards, at the rate of about one-sixteenth of a degree Fahr. per foot, would make the curvature of rays equal to that of the earth, so that a ray might encircle the globe. Any increase in the downward bending of rays increases the range of vision, by enabling them to bend round the horizon, which previously limited the view. The visible effect is precisely the same as if the convexity of the surface of the earth were diminished. And not only will objects which were previously beyond the horizon be brought into view, but objects which were previously visible near the horizon will become plainer, inasmuch as the rays by which they are seen will not pass so close to the intervening surface as before, but will traverse a higher portion of the air, which is less liable to be obscured by impurities.

Having now laid down the first principles, to which all effects of atmospheric refraction must be traced, we will proceed to some more particular applications.

I have recently been considering the question—what must be the law of density (or, more strictly, of refractive index) in a horizontally stratified atmosphere, in order that images formed by mirage may be perfectly sharp? and some of the diagrams placed before you will serve to explain the results which I have obtained.

First.—Neglect the curvature of the earth, and suppose the surface of uniform index to be plane; then the law required is as follows:—There must be a plane of maximum index, at which the rate of variation of index with height must be zero; and as we ascend or descend from this plane of reference the rate of variation of index must continually increase in direct proportion to the distance. The rate must also be the same at equal distances above and below this plane of reference. The curvature of a horizontal, or nearly horizontal ray, will thus be simply proportional to distance from the plane of reference, and the bending from either side will be towards this plane. Rays may accordingly pierce this plane (which is indicated by a dotted line in Figs. 1 and 2) again and

again, any number of times, and every time that they do so they will undergo a reversal of curvature. The curvature at the point of crossing will be *nil*. The curves described will be what are called "harmonic curves," or "curves of sines," such as are represented in Figs. 1 and 2; subject to the restriction that we have only to do with rays which are so nearly horizontal that the cosines of their inclinations may be treated as unity. The distance between consecutive intersections will be the same for all



PLATE II.

the curves, and is easily computed in terms of the constant which enters into the expression for the variation of index. A pencil of rays diverging in the same vertical plane from a point in the plane of reference, will thus converge accurately to another point in the plane, as represented in Fig. 1. Such a pair of points may be called principal conjugate foci. But this property of accurate convergence is not confined to pencils proceeding from points in the plane of reference. The same property attaches to pencils diverging from any point whatever; the conjugate focus

being always a point at the same distance on the other side of the plane of reference, and the horizontal distance between the two being the same as in the preceding case. This property is illustrated by Fig. 2.

It is obvious that the conjugate foci will occur not in pairs merely, but in sets of unlimited number; that is to say, raised proceeding originally from any one point will converge in succession to an indefinite number of other points, which will be alternately on opposite sides of the plane of reference. As every point on the surface of an object will thus have its conjugates, we shall have a succession of images of the object. The first image will be upside down, the second erect, and so on alternately. They will be what are technically called "real" images, and will be precisely equal and similar (except as regards inversion) to the object itself. It is of course to be understood that the action here described is confined to one dimension only, resembling that of a cylindrical rather than of a spherical lens. Rays are bent to and from the plane of reference, but in no other direction. This theoretically simple case is so important for the light which it throws upon the possibilities of atmospheric refraction, that we shall examine some of its consequences a little further.

What will be the appearance presented to the eye of an observer in any given position?

The case differs greatly from that of the images in ordinary optics, where the refracting instruments are glass lenses, and the eye sees the image by means of rays which travel in straight lines.

In the case now before us, the observer will in general see a virtual image, differing considerably, both in size and direction, not only from the object itself, but also from any one of the real images. The apparent direction of any point of the visible image is of course determined by drawing a tangent to the ray which enters the eye\* (Figs. 6 and 7); and the visual angle, or, as we may call it, the apparent size of the object, will be the angle between two of these tangents. If the eye is a little distance (say a few feet) behind one of the real images, enormous magnification will be produced, for the image has the same linear height as the object, and is seen from a distance of a few feet, instead of from the real distance of the object, which we may suppose to be a few miles. We shall thus have enormous magnification of the vertical diameter of the object, while the horizontal diameter will of course be only of the natural size, since the rays have undergone no bending except up and down. An object whose breadth is equal to its height will thus be magnified into a tall column. Some appearances of this kind, copied from Scoresby's "Greenland," are represented in the first two figures of Plate II. The following is Scoresby's description ("Greenland," p. 96):—

"Hummocks of ice assumed the forms of castles, obelisks, and spires, and the land presented extraordinary features. In some places the distant ice was so extremely irregular, and appeared so full of pinnacles, that it resembled a forest of naked trees; in others it had the character of an extensive city crowded with churches, castles, and public edifices."

Again, on page 163 of the same work:—

"At one period the phenomenon was so universal that the space in which the ship navigated seemed to be one vast circular area, bounded by a mural precipice of great elevation, of basaltic ice."

The magnificent columns which constitute a portion of the wonders of the Fata Morgana, at the Straits of Messina, are in like manner to be attributed to vertical magnification. And an appearance of the same kind, known as "the merry dancers," is often seen by boatmen off the Giant's Causeway, in looking over the Skerries towards Portrush.

\* The letter E, in all the figures, denotes the position of the observer's eye.

If we could have density distributed symmetrically round an axis, instead of on the two sides of a plane, we might of course have magnification without distortion. But we can scarcely conceive of any arrangement at all resembling this existing in the atmosphere.

It is further to be remarked, that the apparent distance of one of our columnar images from the observer's eye is an ambiguous quantity. If judged by left and right displacement, it is the real distance of the object. If judged by up and down displacement, it is much less, being approximately the distance of the real image.

(To be continued.)

#### SOME REMARKS ON DALTON'S FIRST TABLE OF ATOMIC WEIGHTS\*

AS the Society is aware, the first table, containing the relative weights of the ultimate particles of gaseous and other bodies, was published as the eighth and last paragraph to a paper by Dalton on the absorption of gases by water and other liquids, read before this Society on Oct. 21, 1803, but not printed until the year 1805. There appears reason to believe that these numbers were obtained by Dalton after the date at which the paper was read, and that the paragraph in question was inserted at the time the paper was printed. The remarkable words with which he introduces this great principle give us but little clue to the methods which he employed for the determination of these first chemical constants, whilst in no subsequent publication, as in none of the papers which have come to light since his death, do we find any detailed explanation of how these actual numbers were arrived at. He says,† "I am nearly persuaded that the circumstance" (viz., that of the different solubilities of gases in water) "depends upon the weight and number of the ultimate particles of the several gases: those whose particles are lightest and single being less absorbable, and the others more, according as they increase in weight and complexity. An inquiry into the relative weights of the ultimate particles of bodies is a subject, as far as I know, entirely new. I have been lately prosecuting this inquiry with remarkable success. The principle cannot be entered upon in this paper; but I shall just subjoin the results, as far as they appear to be ascertained by my experiments."

Here follows the table of the relative weights of the atoms.

Table of the Relative Weights of the Ultimate Particles of Gaseous and other Bodies.

Hydrogen ... ..	1
Azot ... ..	4.2
Carbon ... ..	4.3
Ammonia ... ..	5.2
Oxygen ... ..	5.5
Water ... ..	6.5
Phosphorus ... ..	7.2
Phosphuretted hydrogen ... ..	8.2
Nitrous gas ... ..	9.3
Ether ... ..	9.6
Gaseous oxide of carbon ... ..	9.8
Nitrous oxide... ..	13.7
Sulphur ... ..	14.4
Nitric acid ... ..	15.2
Sulphuretted hydrogen ... ..	15.4
Carbonic acid... ..	15.3
Alcohol ... ..	15.1
Sulphurous acid ... ..	19.9
Sulphuric acid ... ..	25.4
Carburetted hydrogen from stagnant water... ..	6.3
Olefiant gas ... ..	5.3

In the second part of his "New System of Chemical Philosophy," published in 1810, Dalton points out, under the description of each substance, the experimental evi-

\* By Prof. H. E. Roscoe, F.R.S.; read before the Literary and Philosophical Society of Manchester, Nov. 17, 1874.

† Manch. Mem., vol. i., Second Series, p. 286.

dence upon which its composition is based, and explains, in some cases, how he arrived at the relative weights of the ultimate particles in question. Between the years 1805 and 1810, however, considerable changes had been made by Dalton in the numbers; the table found in the first part of the "New System" being not only much more extended, but, in many cases, the numbers differing altogether from those given in the first table published in 1805. It is therefore now, to a considerable extent, a matter of conjecture how Dalton obtained the first set of numbers; all we know is that it was mainly by the consideration of the composition of certain simple gaseous compounds of the elements that he arrived at his conclusions, and in order that we may form some idea of the data he employed, we must make use of the knowledge which chemists at that time (1803-5) possessed concerning the composition of the more simple compound gases.

As I can find no record of any explanation of these early numbers, I venture to bring the following attempt to trace their origin before the Society to whom we owe their publication.

The first point to ascertain, if possible, is how Dalton arrived at the relation between the atomic weights of hydrogen and oxygen given in the table as 1 to 5.5 (but altered to 1 to 7 in 1808). The composition of water by weight had been ascertained by the experiments of Cavendish and Lavoisier to be represented by the numbers 15 of hydrogen to 85 of oxygen, and this result was generally accepted by chemists at the time, amongst others doubtless by Dalton. Whether in those early days Dalton had actually repeated or confirmed these experiments appears improbable. At any rate, he formed the opinion that water was what he called a binary compound, *i.e.*, that it is made up of one atom of oxygen and one atom of hydrogen combined together. Hence, if he took the numbers 85 to 15 as giving the composition of water, the relation of hydrogen to oxygen would be 1 to 5.6, or nearly that which he adopted. It does not appear possible to explain why Dalton adopted 5.5 instead of 5.6 for oxygen; it may, perhaps, have been a mistake, as there are two evident mistakes in the table, *viz.*, 137 for nitrous oxide instead of 139, and 9.3 for nitrous gas instead of 9.7.

Let us next endeavour to ascertain how he obtained the number 4.3 for carbon (altered to 5 in 1808 and to 5.4 later on). Lavoisier, in the autumn of 1783, had ascertained the composition of carbonic acid gas by heating a given weight of carbon with oxide of lead, and he came to the conclusion that this gas contained 28 parts by weight of carbon to 72 parts by weight of oxygen. Now Dalton not only was acquainted with the properties and composition of carbonic acid, but he was aware that Cruikshank had shown in 1800 that the only other known compound of carbon and oxygen, carbonic oxide gas, yields its own bulk of carbonic acid when mixed with oxygen and burnt; and also that Desormes\* analysed both these gases, finding carbonic oxide to contain 44 of carbon to 56 of oxygen, whilst carbonic acid contained to 44 of carbon 112 of oxygen, being just double of that in the carbonic oxide. Dalton adds: "This most striking circumstance seems to have wholly escaped their notice." Hence Dalton assumed that one atom of carbon is united in the case of carbonic oxide with one atom of oxygen, whilst carbonic acid possessed the more complicated composition and contains two atoms of oxygen to one of carbon. Now, if carbonic acid contains carbon and oxygen in the proportion of 28 to 72, carbonic oxide must contain half as much oxygen, *viz.*, 28 of carbon to 36 of oxygen; and assuming that the atomic weight of oxygen is 5.5, that of carbon must be

$$\frac{28 \times 5.5}{36} = 4.3.$$

Having thus arrived at the number 4.3 as the first

\* Ann. der Chem., tome 39, p. 38.

atomic weight of carbon, it is easy to see why Dalton gave 6.3 as the atomic weight of carburetted hydrogen from stagnant water, and 5.3 as that of olefiant gas. The one represents one atom of carbon to two of hydrogen, the other one of carbon to one of hydrogen; or, olefiant gas contains to equal quantities of carbon only half as much hydrogen as marsh gas. This conclusion doubtless expressed the results of Dalton's own experiments upon these two gases, which were made, as we know from himself, in the summer of the year 1804. He proved that neither of these gases contained anything besides carbon and hydrogen, and ascertained, by exploding with oxygen in a Volta's eudiometer, that if we reckon the carbon in each the same, then carburetted hydrogen contains exactly twice as much hydrogen as olefiant gas does, and that "just half of the oxygen expended on its combustion was applied to the hydrogen, and the other half to the charcoal. This leading fact afforded a clue to its constitution." Whereas, in the case of olefiant gas, two parts of oxygen are spent upon the charcoal, and one part upon the hydrogen.

The atomic weight of nitrogen (azote = 4.2) was doubtless obtained from the consideration of the composition of ammonia, whose atomic weight is given in the table at 5.2. Ammonia was discovered in 1774 by Priestley, but the composition was ascertained by Berthollet in 1775 by splitting it into its constituent elements by means of electricity, when he came to the conclusion that it contained 0.193 parts by weight of hydrogen to 0.807 parts by weight of nitrogen. Dalton assumed that this substance is a compound of one atom of hydrogen with one of nitrogen, and hence he obtained for the atomic weight of azote  $\frac{807+1}{193} = 4.2$ ; and  $4.2+1 = 5.2$

as the atomic weight of ammonia. It is also probable that Dalton made use of the composition of the oxides of nitrogen for the purpose of obtaining the atomic weight of nitrogen. If we take the numbers obtained partly by Davy and partly by himself, as given on page 318 of the "New System," as representing the composition of the three lowest oxides, it appears that the mean value for nitrogen is 4.3 when oxygen is taken as 5.5. In all probability the number in this table (4.2) was obtained from an experiment of Dalton's made at an earlier date.

It is not possible to ascertain the exact grounds upon which Dalton gave the number 7.2 for phosphorus; its juxtaposition, however, in the table, to phosphuretted hydrogen, shows that it was probably an analysis or a density determination of this gas which led him to the atomic weight 7.2, under the supposition that this gas (like ammonia) consisted of one atom of each of its components. In the second table, published in 1808, Dalton gives the number 9 as that of the relative weight of the phosphorus atom, and we are able to trace the origin of this latter number, although that of 7.2 is lost to us. On p. 460, Part II. of his "New System," Dalton states that he found 100 cubic inches of phosphuretted hydrogen to weigh 26 grains, the same bulk of hydrogen weighing 2.5 grains. Hence  $\frac{26-2.5}{2.5} = 9$  gives the atomic weight of phosphorus. It was probably by similar reasoning from a still more inaccurate experiment than this one, that he obtained the number 7.2.

Sulphur, which stands in the first table of 1803 at 14.4, was altered in the list published in the "New System" to 13. These numbers were derived from a consideration (1) of the composition of sulphuretted hydrogen, which he regarded as a compound of one atom of sulphur with one of hydrogen, and (2) of that of sulphurous acid, which he supposed to contain one atom of sulphur to two of oxygen. Dalton knew that the first of these compounds contained its own volume of hydrogen, and he determined its specific gravity, so that by deducting from the weight of one volume of the gas that of one volume of hydrogen, he

would obtain the weight of the atom of sulphur compared to hydrogen as the unit. The specific gravity he obtained was about 1.23—corresponding nearly, he says (p. 451) to Thénard's number, 1.23. Hence (as he believed air to be twelve times as heavy as hydrogen) he would obtain the atomic weight of sulphur as  $(12 \times 1.23) - 1 = 13.76$ , which number, standing half way between 14.4 as given in the first table, and 13 as given in the second, points out the origin of the first relative weight of the ultimate particle of sulphur. So from sulphurous acid he would obtain a similar number, taking the specific gravity as obtained by him (Part ii., 389) to be 2.3, and remembering that this gas contains its own bulk of oxygen (p. 391), he obtained  $(2.3 - 1.12) \times 12 = 14.16$  for the atomic weight of sulphur. As, however, we do not possess the exact numbers of his specific gravity determinations, and as we do not exactly know what number he took at the time as representing the relation between the densities of air and hydrogen (in 1803 he says that the relation of 1 : 0.077 is not correct, and that  $\frac{1}{13}$  is nearer the truth), it is impossible to obtain the exact numbers for sulphur as given in the first table.

In reviewing the experimental basis upon which Dalton founded his conclusions, we cannot but be struck with the clearness of perception of truth which enabled him to argue correctly from inexact experiments. In the notable case, indeed, in which Dalton announces the first instance of combination in multiple proportion (Manch. Mem. vol. i., series ii., p. 250), the whole conclusion is based upon an erroneous experimental basis. If we repeat the experiment as described by Dalton, we do not obtain the results he arrived at. Oxygen cannot as a fact be made to combine with nitric oxide in the proportions of one to two by merely varying the shape of the containing vessel; although by other means we can now effect these two acts of combination. We see, therefore, that Dalton's conclusions were correct, although in this case it appears to have been a mere chance that his experimental results rendered such a conclusion possible.

#### INTERNATIONAL METRIC COMMISSION AT PARIS

THE Permanent Committee of the International Metric Commission, elected from among the members at their general meeting at Paris, in 1872, has just concluded a series of meetings, the first of which was held on October 6. The Committee were directed to meet at least once a year, in order, amongst other things, to examine the progress of the work of the French Section, to whom the construction of the new standards was entrusted, with a view to the concurrence of the Committee as the executive organ of the Commission.

At their recent meetings, the Committee fully considered and discussed a detailed report of the proceedings of the French Section since the melting of the great ingot of platinum-iridium on May 13 last, from which all the new International Metric Standards are to be made (an account of which was given in NATURE, vol. x. p. 130); and, generally speaking, the Committee expressed their unanimous concurrence and satisfaction at the mode in which the French Section have hitherto executed the duties entrusted to them by the Commission, and they also gave their decisions on certain points submitted to them for the guidance of the French Section in their future operations.

The first operation to which the great ingot of 250 kilogrammes of platinum-iridium was submitted, when in its rough state, and cleansed from all extraneous matter, was to have all the inequalities on its surface, that had been in contact with the lime of the calcined furnace, removed with a cold chisel. The ingot with its surface thus smoothed was found to weigh 236.330 kilogrammes. In this state it was exhibited to the Académie des

Sciences at their *séance* of July 2, 1874. A portion of this large homogeneous mass of metal, when analysed by M. Henri Saint-Claire Deville, showed the proportion of iridium to be 10.29 per cent.

The ingot was next forged by M. M. Farcot under a steam hammer weighing 5,000 kilogrammes, until by successive hammerings and annealings, in a single day, it was brought to the form of a bar five centimetres square in section. By similar operations this bar, divided into convenient lengths, was afterwards further reduced to eight bars 2.5 centimetres square in section, and of a total length of 16.405 metres.

A remarkable phenomenon was observed by M. Tresca during the forging of these bars, and was communicated by him to the Académie des Sciences at their *séance* of July 9. At the moment when the hammer struck the bar, lines of light were seen to pass downwards from the edges of the hammer, and to cross each in the form of an X on each of the side surfaces of the bar. These lines continued afterwards distinctly visible in a certain light, appearing like slightly burnished marks.

The next operation was to prepare the bars for drawing into the X form, by cutting longitudinal grooves along the middle of each of the four sides of the bars by means of a planing machine. A further object of cutting these grooves was to ascertain if there were any flaws on the surface of the metal so exposed, as it was found absolutely necessary to remove any such flaws, else they would remain as blemishes on the surfaces of the bars when drawn.

The eight bars were next submitted by M. Guedry, at the Audincourt foundry, to successive operations of drawing out and annealing, until they were accurately reduced to the X form of the Tresca section, when each was extended to a length sufficient to make three or four metre bars. The first of the grooved bars was passed through the dies no less than 220 times, and was as often subjected to annealing. It was afterwards ascertained that the rigidity of the drawn bars was but little affected by the process of annealing, their co-efficients of elasticity being found as follows:—

Before annealing	...	...	21.2085
After annealing	...	...	21.0073

Their co-efficient of expansion was also found to be but very slightly changed, and in the opposite direction, viz.—

Co-efficient of expansion for 1° C. at mean t. 40° C. Variation for mean t. 1° C.			
Before annealing	...	0.0000380,2	0.84
After annealing	...	881,9	0.86

When divided into finished bars of the X section, 1.02 m. in length, each bar is made perfectly straight by special arrangements contrived for this purpose. Four straight edges of steel are made exactly to fit into the grooves of the X bar, and to form, when so fitted, a rectangular bar two centimetres square in section. This square bar is then enclosed between the plane surfaces of four solid rectangular iron bars; and all being tightly compressed with iron clamps in the form of hollow squares and with iron wedges, the whole is heated in a furnace till red hot, when the clamps are further tightened and the mass of metal is left to cool. By this operation, each of the X metre bars is made perfectly straight. Up to the present time bars of the X section have been made sufficient for more than thirty metres.

The polishing of the surface of the X bars next follows. This is effected by the use of polishing powder and powdered charcoal. Particular attention is given to the polishing and subsequent burnishing of that portion of the surface of the metal on which the defining lines are to be cut. Several experiments which have been made tend to show that the best surface for cutting the lines will be obtained by the final operation of slightly impressing a stamp of highly polished steel, of the dimensions of 3 mm. by 2 mm. By this means an identical



surface for receiving the defining lines may be given to every one of the new metres.

The apparatus for cutting the lines is connected with the new longitudinal comparing apparatus, carrying a microscope with its micrometer. The microscope is 0.8 m. in length and magnifies more than 200 times; and the whole apparatus is placed in the cold chamber, which has been constructed at the Conservatoire des Arts et Métiers, and can be maintained constant at the normal temperature of 0° C. The polishing of the bars, as well as the cutting of the defining lines, the position of which must necessarily be the result of the most precise comparisons with the primary standard metre, are both entrusted to M. Tresca and his son, M. Gustave Tresca.

The lines are to be cut with a diamond point. Each transverse defining line will be crossed at right angles by two longitudinal lines 0.1 mm. apart, and the portion of the transverse line so intercepted between the two lines will define the length of the metre. The width of these lines will probably be about 0.002, or at most 0.003 mm., or 3 microns ( $\mu$ ). This will be about one-fourth of the thickness of the defining lines of our standard yards, which are cut with a steel knife upon the polished surface of a gold stud, and are viewed through microscopes magnifying about sixty times.

Great progress has been made in the construction of the series of new thermometers, two of which are to accompany each international standard metre. These thermometers are being constructed by M. Baudin. Their length is 0.45 m., and their external diameter 5 mm. The bulbs have the same external diameter, and the two thermometers can thus be placed in the groove of the X metre bar for determining the temperature of its measuring axis during comparisons under the microscopes. The scale of the thermometers ranges from -5 to +50° C., and each degree is subdivided into tenths. Every 1° corresponds with a length of about 7 mm. Four standard thermometers have been constructed for the purpose of verifying the new metre thermometers. They have an arbitrary scale from 0° to 100° C., graduated in half-millimetres by hydrofluoric acid on the glass tubes, and the value of the several graduations has been accurately determined by calibration. The length of these standard thermometers somewhat exceeds 0.50 m.

The construction of the new international kilogrammes and of the standard *mètres-à-bouts* will be deferred until the completion of the number of *mètres-à-trails* required. Meanwhile, several balances of the greatest precision have been obtained for the weighings, some of which are fitted with mirrors for observing the extent of the oscillations through a telescope by means of a vertical graduated scale fixed to the telescope and reflected in the mirror, according to the principle adopted by Gauss for observing variations of the magnetic needle.

For ascertaining the atmospheric pressure during the weighings, the standard barometer of the Conservatoire des Arts et Métiers, constructed by Faure, is proposed to be used, by which the height of the mercury can be read to 0.01 mm. An ingenious apparatus has been constructed by M. Mendeleef, which shows the slightest variation of pressure during the process of weighing, by means of a small U-tube containing oil of petroleum. One end of this tube is closed and contains a certain volume of dry air maintained at a constant temperature, whilst the other end is open to the air. The instrument being accurately adjusted by means of a mercurial plunger connected with the bottom of the U-tube, so that the petroleum is exactly on a level on the two branches of the tube, it is found to be so extremely sensible that the slightest variation of atmospheric pressure is shown by an alteration of the level, and the amount of this alteration can be measured with the greatest precision.

It is expected that the whole series of new *mètres-à-trails* will be completed by the French Section and ready

to be handed over to the Comité Permanent by October 1875, and that the construction of the new kilogrammes and *mètres-à-bouts* will also be far advanced by that date.

During their late meeting, the question of the convocation of a Diplomatic Conference at Paris with the view of providing the requisite means for enabling the committee to execute all the definite comparisons of the new metric standards, and for securing the due preservation of the new international metric prototypes and regulating their use for future comparisons, was further considered by the Committee. In pursuance of their resolution of last year upon this subject, the requisite communications were made by the French Government to the Governments of the several countries interested, and the Committee have now passed a resolution that considering the numbers of Governments who have agreed to take part in such conference, the French Government be requested to convocate it with as little delay as possible. Information has been received of the willingness of the French Government to accede to the request, and the Conference will probably be held in the spring of next year.

H. W. CHISHOLM

### NOTES

It is with the greatest pleasure and with something like a sense of relief that we are able at last to announce definitely that at a Cabinet Council held last Saturday it was decided that there should be an Arctic Expedition, at the expense of Government, to sail next spring. The welcome intelligence was thus announced by Mr. Disraeli to Sir Henry Rawlinson:—"Her Majesty's Government have had under consideration the representations made by you on behalf of the Council of the Royal Geographical Society, the Council of the Royal Society, the British Association, and other eminent scientific bodies, in favour of a renewed expedition, under conduct of Government, to explore the region of the North Pole, and I have the honour to inform you that, having carefully weighed the reasons set forth in support of such an expedition, the scientific advantages to be derived from it, its chances of success, as well as the importance of encouraging that spirit of maritime enterprise which has ever distinguished the English people, her Majesty's Government have determined to lose no time in organising a suitable expedition for the purposes in view." Steps have, we believe, been already taken to carry into effect this resolution, which reflects so much credit on her Majesty's Government. Admiral McClintock left for Dundee on Tuesday with an engineer and shipwright, to buy two steam whalers, which will be fitted out under the tried explorer's superintendance at Portsmouth. Capt. A. H. Markham, who went to Baffin's Bay last year, will probably occupy an important post in the expedition, the route of which will, of course, be Smith's Sound. Now that the thing has been decided on, there is no doubt that it will be thoroughly well done; and now that Englishmen have once more got the chance, we may expect something like real work, if, indeed, they do not take the last step in the solution of the Arctic mystery.

We take the following from the *Times*:—"The medals in the gift of the Royal Society for the present year have been awarded by the Council as follows, and will be presented at the anniversary meeting on the 30th inst.:—The Copley Medal to Prof. Louis Pasteur, of the Academy of Science, Paris, For. Mem. R. S., for his researches on Fermentation and on Pebrine. The Rumford Medal to Mr. J. Norman Lockyer, F.R.S., for his spectroscopic researches on the sun and on the chemical elements. A Royal Medal to Prof. William Crawford Williamson, F.R.S., of Owens College, Manchester, for his contributions to zoology and paleontology, and especially for his investigations into the structure of the fossil plants of the coal-measures; and a Royal Medal to Mr. Henry Clifton Sorby, F.R.S., for his

researches on slaty cleavage and on the minute structure of minerals and rocks, for the construction of the micro-spectroscope, and for his researches on colouring matters.

We are very glad to be able to announce that Prof. Maskeyne's lectures on Crystallography to the Chemical Society are likely to be well attended. The first lecture will be given on Monday evening next, at 8.30, at Burlington House.

LAST week some engineers visited the National Library, Paris, on behalf of the Japanese Government, to take measurements for the purpose of building a large public library in Japan on the same plan. The magazine and reading-rooms of Paris have, with some improvements, been built on the system of the British Museum.

THE report of the Potato Disease Committee of the Royal Agricultural Society has been recently published. It will be recollected that three years ago Earl Cathcart offered a prize of 100*l.* for essays on the prevention of the disease. Although no fresh practical information was elicited, and it may perhaps be said no direct good came from this well-meant offer, the Society took the subject up and offered prizes for potatoes reputed to be proof against disease. Two prizes were offered for the commencement of this year, for potatoes of varieties already known, and two are to be awarded five years hence for varieties that may be produced by cultivation before that period. Six different varieties were sent in, 1 ton (twenty bags of 1 cwt.) of each. The Society arranged to have these practically tested. Twelve stations in England, four in Scotland, and four in Ireland were selected, and 1 cwt. of each variety sent for planting, of these so-called disease-proof potatoes. During the summer the botanic referee of the Society visited all the localities, and in all cases disease was found. Much valuable information is likely to arise from the statistics that have been collected, for although it seems that no indication is given of how the disease can be prevented, yet under certain conditions, principally influenced by moisture, its effect is but small. Prof. de Bary has worked out the scientific questions that occur as to the origin of the disease. It is owing to a fungus (*Peronospora infestans*), which attacks the leaves first, and after absorbing the nutriment of them, utilises the petioles, and thus reaches the tubers. A further report of the Committee, based on the statistics sent in, is shortly to be expected.

We greatly regret to announce the death of Mrs. Hooper, the wife of the Director of the Royal Gardens, Kew, and President of the Royal Society, which took place on Friday, Nov. 13, very suddenly. She was the translator of Le Maout and Decaisne's "Traité général de Botanique." She will be missed by a large circle of scientific friends.

THE death of Dr. Archibald Campbell will be regarded as a severe loss by his colleagues in scientific societies and by many of the Indian public. He was sixty-nine years of age, and till lately appeared hale and hearty. As Superintendent of Darjeeling, he became a leading authority of reference on the natural history, geography, and ethnography of Thibet, Nepal, Sikkim, and Bhootan. He was distinguished as an administrator, and under his government and auspices Darjeeling has risen from an obscure sanitarium for invalid soldiers to be a settlement of some consideration. He was the author of several memoirs and notes.

We have to record the death, on Monday last, in his fifty-sixth year, of Dr. Edward Smith, F.R.S., Assistant Medical Officer, for Poor-law purposes, to the Local Government Board. Dr. Smith's excellent observations on quantitative physiological cyclical phenomena, many of which were conducted on himself, are too well known to require special mention; they indicate an amount of energy and willingness to experience personal incon-

venience for the sake of his favourite subject which is very rarely to be met with. His observations on dietaries, especially with regard to the Manchester cotton famine, are also of considerable importance.

We hear that a new method has been proposed for crossing the Channel; this is to construct an artificial isthmus between the French and English sides, leaving a very small space in the centre for the passage of ships. The expense would not be much larger than that of boring a tunnel, and the advantages would in some respects be greater.

THE International Congress of Orientalists has been the means of originating in Paris a new society under the title of Société d'Études Japonaises, Chinoises, Tartares, and Indo-chinoises. The number of members already amounts to sixty. At a recent meeting of the Society, M. Boursset exhibited a game for teaching children in a few hours the elements of which Chinese letters are made—*omne tulit punctum qui miscuit utile dulci*. M. Boursset has also shown another invention for diminishing the number of letters which must be cut, and therefore of diminishing the cost of printing Chinese works.

M. LEVERRIER is constructing, in the recently annexed garden of his observatory, a basis for comparing accurately, by superposition, standard measures of length with the metre. The first comparison will be made between the Archives metre and the celebrated Boscovitz rule, which was used more than a century ago for determining the length of two degrees in the Papal States.

IN a paper read before the Paris Société d'Acclimation, Dr. Turrel suggests that the rapid spread of the *Phylloxera vastatrix* in France may be due to the scarcity of small birds in that country. Forty years ago, he says, linnets, tits, &c., were numerous in Provence, and in the autumn they could be seen posted on the vine branches, carrying on a vigorous search after the insects, and larvae and eggs of insects, concealed in the cracks of the stem and leaves of the plant. Since the commencement of the present century, however, it is easy to perceive that the destruction of small birds has been carried on more and more generally; and that, concurrently with this war of extermination against the feathered tribes, the numbers of destructive insects have increased at an alarming rate. Dr. Turrel thinks that, though it cannot be absolutely maintained that the oidium and the Phylloxera, the two latest forms of vine disease (the one a vegetable, the other an insect parasite), owe their frightful extension to the scarcity of small birds, yet it is unquestionable that a plant like the vine, weakened by the attacks of insects, is less in a condition to withstand the ravages of parasites; and that, deprived of its feathered protectors and left to the successive and unchecked onslaught of the vine grub and other normal enemies, it has been predisposed to succumb before the ravages of its new enemies. The obvious moral is that the French are themselves partly to blame for their indiscretion in killing the useful small birds.

THE commotion created in the Paris School of Medicine by the false rumour spread by the *Figaro* has been beyond bounds; not only was M. Wurtz, the Dean, cheered, but M. Chauffard, one of the professors belonging to the clerical party, was hooted, and unable to deliver his lecture. The disorder having been renewed in spite of all precautions taken by M. Wurtz, the School of Medicine has been closed for a month. If students again exhibit a riotous spirit, the ringleaders will be prosecuted before a Council of War; which is a lawful proceeding, Paris being placed under a state of siege.

STROMBOLI is reported to have recently shown symptoms of revived action.

THE next Triennial Prize of 300*l.* under the will of the late Sir Astley P. Cooper, Bart., will be awarded to the author of the best essay or treatise on "The Anatomy, Physiology, and Pathology of the Sympathetic Nervous System."

WE learn from *Hansa* of the 15th inst. that the following amounts have been included in the estimates for 1875, presented to the Imperial German Parliament for the service of the "Deutsche Seewarte"—

A.—Salaries and Remunerations.	
1. Central Station ... ..	39,000 marks
2. Branch Stations ... ..	11,000 "
B.—Contingent Expenses.	
1. Central Station ... ..	20,000 "
2. Branch Stations ... ..	4,800 "
Total ... ..	74,800 marks

which, at the rate of twenty marks to the sovereign, amounts to 3,700*l.* Two new departments are to be added to that established at Hamburg for Marine Meteorology, viz., for Storm-warnings and Magnetism.

A HONG KONG telegram of the 16th inst. states that the *Challenger* had arrived there from Australia.

WE hear that a Horticultural Club is about to be formed in London, and the preliminary steps that have been taken promise well.

THE last number of the *Gardener's Chronicle* states that a specimen of *Aralia sieboldi* at Kew is now in bloom, and that a new garden plant, *Raphidophora lancifolia*, is now in cultivation in this country.

A SLIGHT shock of earthquake was felt in Carnarvonshire and Anglesea on Sunday morning.

FROM a private letter dated Mauritius, Oct. 15, we learn that Lord Lindsay had not yet arrived at that island, that the Germans were expected on the 25th, that the Dutch were at their post at Bourbon, and the English the same at Rodriguez.

THE Earl of Derby has been elected by the Edinburgh students as their Lord Rector, and Mr. Disraeli has been re-elected by the *ingeniis adolescentes* of Glasgow University.

EVERY term at Dulwich College a course of scientific evening lectures is given, open to the students and their friends. This term, for the first time, the applications for tickets have exceeded the accommodation of the lecture theatre. The present course is on Geology, by Prof. Harry G. Seeley, the titles of the lectures being, "The Origin and Internal Structure of the Earth," "The Origin and Succession of the Strata," "The Succession of Life on the Earth," and "The Influence of Geological Phenomena on Men and Animals."

THE Committee of Directors of the Crystal Palace Company's School of Art, Science, and Literature have made arrangements for the delivery of successive short series of lectures on special subjects by gentlemen of eminence in art, science, and literature. These lectures will be purely educational in character, and, as far as possible, complete in themselves, but will not in any way supplant the permanent private classes, to which they are designed to be accessory. They are intended to stimulate independent thought, and to lead the student to a conception of some of the ulterior aims of the studies she pursues. They will be delivered in the largest class-room of the school, generally on Fridays, in the afternoon; and the most moderate fee that is possible in each case will be fixed. Ladies only will be admitted. The first course will be of six lectures on "The Interpretation of Nature as it relates to Man and his Education," by the Rev. Chas. Pritchard, M.A., F.R.S., Savilian Professor of Astronomy in

the University of Oxford. Fridays—November 13, 20, 27; December 4, 11, 18; to commence each day at half-past three.

AT Emmanuel College, Cambridge, there will be an examination for open scholarships in natural science, commencing the 6th of April, 1875. There is no limit as to age, but all candidates will have to satisfy the examiners that they possess such a knowledge of mathematics and classics as will enable them to pass the Previous Examination. The subjects of examination are botany, chemistry, chemical physics, geology and mineralogy, zoology, comparative anatomy, and physiology. Candidates must send their names, with copy of register of birth and a certificate of good conduct from some M.A. of the University, to the tutor of Emmanuel, on or before March 31. A candidate for a scholarship may also be eligible without further examination for a scholarship at Christ's or Sidney Colleges, in default of properly qualified candidates at those colleges.

A JOINT examination will be held at Clare College and Gonville and Caius College, Cambridge, on Tuesday, March 16, 1875, and three following days, when two scholarships for natural sciences will be offered for competition to students intending to commence residence in October 1875, each of the value of 60*l.* per annum, tenable for two years, but subject to extension or exchange for scholarships of longer tenure. Candidates are required to send their names, with certificates of age and testimonials of good conduct, to one or other of the respective tutors, the Rev. N. M. Ferrers, tutor of Caius, or the Rev. W. Raynes, tutor of Clare, stating at which college they prefer to be elected; but if not elected at such college it will be understood that they are candidates also at the other college. Further particulars may be obtained on application to the tutor of Clare or the tutor of Caius.

THERE was a meeting of the members of the Cambridge University Senate on the 12th inst., to discuss the report issued last June of the Board of Natural Science Studies, recommending alterations in the examination for the Natural Science Tripos. Its main recommendations consist of a division of the Tripos. The recommendations met with the unanimous approval of the Senate.

THE following appears in the *Times*:—Where the excavations for laying the water-pipes are being made near Rideau Hall, on the grounds of the Governor-General of Canada, the workmen have made a strange geological discovery. It is a stratum of fossil rock several feet thick, containing the most accurate and beautiful petrified winged insects. There are some like butterflies, with the delicate fibre of the wings in a most perfect state of preservation. Several persons in New Edinburgh have secured excellent specimens.

ON Thursday, Nov. 5, the members of the Geological Society Club dined together at the Pall Mall Restaurant, to celebrate the fiftieth year of the meetings of the Club. There was a good gathering of the members, and among them were the Earl of Enniskillen, Sir Charles Lyell, Profs. Huxley and Ramsay, Mr. Godwin Austen, Mr. Prestwich, Capt. Galton, &c.; some of the past retired members were also present. Letters apologising for absence were read from Mr. Jesse Watts Russell, an original member, the Duke of Devonshire, Earl of Selkirk, Lord Overstone, Mr. Darwin, Sir C. Fox Bunbury, and others. The president of the Geological Society, Mr. J. Evans, took the chair, and the vice-chair was occupied by Mr. Mylne, the treasurer of the Club; some toasts were given, and Sir Charles Lyell, one of the only two original members now living, responding in the name of the Club, took occasion to remark that great as had often been the differences of opinion in the Geological Society from the time of Buckland, Conybeare, De la

Beche, Fitton, Sedgwick, and Murchison, down to the present day, there had always been perfect harmony in the Club. He further congratulated the younger men not only on the zeal and talent displayed among them, but on the progress of opinion and freedom of expression gained by scientific thought in the course of half a century.

ICEBERGS are reported to have been met with in the Bay of Biscay during very rough weather, by the *Mongolia*, which arrived at Southampton on Monday last. Icebergs have been met with as far south, but generally well out in the Atlantic Ocean.

WE invite the attention of all interested in technical education to the very excellent examination scheme of the Society of Arts, intended to promote such education among the working men of the country. No doubt a prospectus of the scheme will be forwarded to anyone writing for it to the Society's offices in London.

IN one of its last sittings the Municipal Council of Paris will have to vote on a proposition, supported by forty of its members, asking the National Assembly to establish a system of public instruction, gratuitous, obligatory, and secular. The motion will probably be agreed to by the Municipal Council, but rejected altogether by the National Assembly.

THE additions to the Zoological Society's Gardens during the past week include eighteen Lancelots (*Amphioxus lanceolatus*) from the Mediterranean Sea, presented by the Director of the Zoological Station at Naples; a Pine Marten (*Martes abietum*), British, presented by Mr. J. Francis; a Red-shouldered Starling (*Agelæus phœnicæus*) from N. America, presented by Mrs. Boxwell; two Aztec Couures (*Comurus aztec*) from S. America, purchased.

## SOCIETIES AND ACADEMIES

### LONDON

**Linnean Society, Nov. 5.**—G. J. Allman, M.D., president, in the chair.—W. H. Archer, R. A. Pryor, and W. W. Wilson were elected Fellows. Mr. J. E. Howard read a paper on the appearances of *Lobelia dortmanna* on the floating island in Derwentwater.—Mr. J. A. Jackson exhibited leaves of *Liquidambar* and *Perottia*, exhibiting remarkably beautiful autumn tints.—Mr. J. G. Baker read a paper on Asparagus, a section of Liliaceæ. The author commenced by discussing the limits of the natural order Liliaceæ. He proposed to regard it as consisting of three great series, and in addition several abnormal tribes, all of which have some claim to be regarded as distinct orders. The three series are:—Liliaceæ proper, characterised by capsular fruit with loculicidal dehiscence, united styles, and introrse anthers (1200 to 1300 species); Colchicaceæ, marked by capsular fruit with septicidal dehiscence, free styles, and extrorse anthers (130 species); and Asparagaceæ, marked by baccate fruit (260 species). The aberrant tribes are Liriopæ (Ophiopogonæ), Gesliæceæ, Conantheræ, Stemonæ (Roxburghiaceæ, Lindley), and Sclopiæceæ. All these have anatroplus ovules; and he advocated the separating of Smilax from Asparagaceæ, with which it has been commonly joined by recent writers, and the retention of it as the type of a separate order marked by orthotroplus ovules, and by its habit of growth, woody often prickly stems, minute polygamous umbellate flowers, stipular tendrils, and decidedly stalked exogen-like leaves with venules reticulated between the palmate main nerves. The tribes and genera of Asparagaceæ, which are as follows, to a considerable extent represent the non-bulbous tribes of the two capsular series:—(1) *Dracæneæ*: Shrubs with proper leaves, hermaphrodite flowers, and introrse anthers; genera, *Dracæna*, *Toetsea* (= *Cordylina*, but used on ground of priority), and *Colmia*; represents Yuccoideæ in Euliaceæ. (2) *Sansevieriæ*: Undershrubs with coriaceous-carnose leaves, hermaphrodite flowers, and extrorse anthers; genera, *Sansevieria*, *Lomatophyllum*; represents closely Aloineæ in Euliaceæ. (3) *Convallariæ*: Herbs with proper leaves, gamophyllous hermaphrodite flowers, and introrse anthers; genera, *Reineckia*, *Convallaria*, *Polygonatum*, *Hylonomæ*; represents Hemerocallideæ in Euliaceæ. (4) *Tovariæ*:

Herbs with proper leaves, polyphyllous hermaphrodite flowers, and introrse anthers, dehiscing longitudinally; genera, *Theronogon*, *Sœcirantha* (new genus founded on *Albica gardeni*, Hook.), *Maianthemum*, *Tovaria* (an earlier name for *Smilacina*), *Drymophila*, *Geitonoplesium*, and *Eustrephus*. (5) *Diantheæ*: Herbs with proper leaves, hermaphrodite flowers, and anthers dehiscing by terminal pores; genera, *Dianella*, *Luzuriæa*. (6) *Aspidistriæ*: Acaulescent herbs, with fleshy, often eight-lobed perianths, hermaphrodite flowers, introrse anthers with longitudinal dehiscence, and large peltate complicated stigmas; genera, *Aspidistra*, *Plectogyne*, *Tupistra*, *Campylandra* (new genus from East Himalayas), *Gonioascypha* (new genus from Bhotan), *Rohleria*. (7) *Streptopææ*: Herbs with proper leaves, hermaphrodite flowers, and extrorse anthers, with longitudinal dehiscence; genera, *Medeola*, *Clintonæa*, *Prosartes*, *Streptopus*, *Callixene*. *Krusea*; represents Colchicaceæ in the capsular series. (8) *Asparagææ*: Herbs or shrubs with leaves degraded down into spurred bract-like membranes, and their place filled by an abundant development of branches in their axils; flowers often polygamous, with introrse anthers dehiscing longitudinally; genera, *Asparagus* (including *Asparagopsis* and *Myrsiphyllum*), *Ruscus*, *Semele*, and *Danae*; the most specialised type of the baccate series, not represented by any tribe in the two capsular sets. The most noticeable points of structure in the series are that, in the first place, such a thing as a bulbous rootstock or a narrow fleshy lorate leaf of the hyacinth type does not occur in Asparagus at all. As regards distribution, it is noticeable that whilst the bulbous tribes of Liliaceæ possess a distinctly-marked geographical individuality, this does not hold good of the non-bulbous half of the natural order; and that the 260 species are scattered all over the world, and not concentrated in any particular geographical area. The most curious structural peculiarity in the group is the degradation of the leaf-organ which marks the tribe Asparagææ. The leaves have an alternate arrangement, and are invariably developed in the form of a minute membranous scale. This has a spur at the base, which in many of the shrubby species of Asparagus is developed out into a woody spine, as firm in texture as the indurated bractlet of the sloe or hawthorn. The function of the leaf is fulfilled by branches, which are developed singly or in fascicles in the axils of these bract-like proper leaves. Sometimes these branches are needle-like (cladodia), without any flattening, as in the common garden asparagus; and sometimes, as in *Myrsiphyllum* and *Ruscus*, they assume all the appearance of proper leaves (phyllocladia). The flowers in the 100 species of the genus *Asparagus* are remarkably uniform, and it is principally upon characters furnished by the shape and arrangement of these barren branches that the species are marked. The stigma of the *Aspidistriæ* is a very curious and complicated organ. It is a plate with eight troughs radiating from a raised central umbilicus, separated from one another by raised walls, and it closes in the tube of the perianth, in which the anthers are placed so thoroughly that it is difficult to tell how fertilisation is effected; but upon turning it upside down four minute holes may be seen, through which it would be possible for a very small insect to creep. The paper was illustrated by plates of the three new genera, and one to show the structure of the stigma of these *Aspidistriæ*; and a large number of new species, especially in the genus *Asparagus*, were described. In the discussion which followed, Dr. Hooker, Dr. Masters, and others expressed their sense of the great value of Mr. Baker's labours.

**Geological Society, Nov. 4.**—John Evans, F.R.S., president, in the chair.—The following communication was read:—Notes on the Comparative Microscopic Rock-structure of some Ancient and Modern Volcanic Rocks, by J. Clifton Ward. The author stated at the outset that his object was to compare the microscopic rock-structure of several groups of volcanic rocks, and in so doing to gain light, if possible, upon the original structure of some of the oldest members of that series. The first part of the paper comprised an abstract of what had been previously done in this subject. The second part gave details of the microscopic structure of some few modern lavas, such as the Solfatara Trachyte, the Vesuvian lava-flows of 1631 and 1794, and a lava of the Alban Mount, near Rome. In the trachyte of the Solfatara acicular crystals of felspar show a well-marked flow around the larger and first-formed crystals. In the Vesuvian and Albanian lavas leucite seems, in part at any rate, to take the place of the felspar of other lavas; and the majority of the leucite crystals seem to be somewhat imperfectly formed, as is the case with the small felspar prisms of the Solfatara rock

The order of crystallisation of the component minerals was shown to be the following:—Magnetite, felspar in large or small distinct crystals, augite, feldspathic or leucitic solvent. Some of the first-formed crystals were broken and rendered imperfect before the viscid state of igneous fusion ceased. Even in such modern lava-flows as that of the Solfatara considerable changes had taken place by alteration and the replacement of one mineral by another, and is very generally in successive layers corresponding to the crystal outlines. The frequent circular arrangement of the glass and stone cavities near the circumference of the minute leucite crystals in the lava of 1631 was thought to point to the fact that after the other minerals had separated from the leucitic solvent, the latter began to crystallise at numerous adjacent points; and as these points approached one another, solidification proceeded more rapidly, and these cavities were more generally imprisoned than at the earlier stages of crystallisation. In the example of the lava of 1794, where the leucite crystals were further apart, this peculiar arrangement of cavities was almost unknown. The third part of the paper dealt with the lavas and ashes of North Wales; and the author thought that the following points were established:—1. Specimens of lava from the Arans, the Arenigs, and Snowdon and its neighbourhood, all have the same microscopic structure. 2. This structure presents a hazy or milky-looking base, with scattered particles of a light-green dichroic mineral (chlorite), and generally some porphyritically imbedded felspar crystals or fragments of such, both orthoclase and plagioclase. In polarised light, on crossing the Nicols, the base breaks up into an irregularly coloured breccia, the colours changing to their complementaries on rotating either of the prisms. 3. Finely bedded ash, when highly altered, is in some cases undistinguishable in microscopic structure from undoubted felstone. 4. Ash of a coarser nature, when highly altered, is also very frequently not to be distinguished from felstone, though now and then the outlines of some of the fragments will reveal its true nature. 5. The fragments which make up the coarser ash-rocks seem generally to consist of felstone, containing both orthoclase and plagioclase crystals or fragments; but occasionally there occur pieces of a more crystalline nature, with minute acicular prisms and plagioclase felspar. 6. In many cases the only tests that can be applied to distinguish between highly altered ash-rock and a felstone are the presence of a bedded or fragmentary appearance on weathered surfaces, and the gradual passage into less altered and unmistakable ash. In the fourth division of his paper the author described some of the lavas and ashes of Cumberland and Lower Silurian age. With regard to these ancient lavas, the following was given as a general definition:—The rock is generally of some shade of blue or dark green, generally weathering white round the edges, but to a very slight depth. It frequently assumes a tabular structure, the tabulae being often curved, and breaks with a sharp conchoidal and flinty fracture. Silica, 59-61 per cent. Matrix generally crystalline, containing crystals of labradorite or oligoclase and orthoclase, porphyritically imbedded, round which the small crystalline needles seem frequently to have flowed; magnetite generally abundant, and augite tolerably so, though usually changed into a soft dark-green mineral; apatite and perhaps olivine as occasional constituents. Occasionally the crystalline base is partly obscured and a felsitic structure takes its place. The Cumberland lavas were shown to resemble the Solfatara greystone in the frequent flow of the crystalline base, and the modern lavas generally in the order in which the various minerals crystallised out. In external structure they have, for the most part, much more of a felsitic than a basaltic appearance. In internal structure they have considerable analogies with the basalts. In chemical composition they are neither true basalts nor true felstones. In petrological structure they have much the general character of the modern Vesuvian lavas; the separate flows being usually of no great thickness, being sluggy, vesicular, or becciated at top and bottom, and having often a considerable range, as if they had flowed in some cases for several miles from their point of eruption. Their general microscopic appearance is also very different from that of such old basalts as those of South Stafford and some of those of Carboniferous age in Scotland. On the whole, while believing that in some cases the lavas in question were true basalts, the author was inclined to regard most of them as occupying an intermediate place between felsitic and doleritic lavas; and as the felstone-lavas were once probably trachytes, these old Cumberland rocks might perhaps be called Felsidolerites, answering in position to the modern Trachy-dolerites. A detailed examination of Cumberland ash-rocks had convinced the author that in

many cases most intense metamorphism had taken place, that the finer ashy material had been partially melted down, and a kind of streaky flow caused around the larger fragments. There was every transition from an ash-rock in which a bedded or fragmentary structure was clearly visible, to an exceedingly close and flinty felstone-like rock, undistinguishable in hand specimens from a true contemporaneous trap. Such altered rocks were, however, quite distinct in microscopic structure from the undoubted lava-flows of the same district, and often distinct also from the Welsh felstones, although some were almost identical microscopically with the highly altered ashes of Wales, and together with them resembled the felstone-lavas of the same country. This metamorphism among the Cumbrian rocks increases in amount as the great granitic centres are approached; and it was believed by the author that it took place mainly at the commencement of the Old Red period, when the rocks in question must have been buried many thousands of feet deep beneath the Upper Silurian strata, and when probably the Eskdale granite was formed, perhaps partly by the extreme metamorphism of the volcanic series during upheaval and contortion. The author stated his belief that the Cumbrian volcanoes were mainly subaerial, since some 12,000 ft. of ash- and lava-beds had been accumulated without any admixture of ordinary sedimentary material, except quite at the base, containing scarcely any conglomeratic beds, and destitute of fossils. He believed also that one of the chief volcanic centres of the district had been the present site of Kenwick, the low craggy hill called Castle Head representing the denuded stump or plug of an old volcano. The author believed that one other truth of no slight importance might be gathered from these investigations, viz., that neither the careful inspection of hand specimens nor the microscopic examination of thin slices would in all cases enable truthful results to be arrived at, in discriminating between trap and altered ash-rocks; but these methods and that of chemical analysis must be accompanied by oftentimes a laborious and detailed survey of the rocks in the open country, the various beds being traced out one by one and their weathered surfaces particularly noticed.

Physical Society, Nov. 7.—Prof. W. G. Adams, F.R.S., in the chair.—A paper by Mr. G. F. Rodwell was read, on an instrument for multiplying small motions. It consists of a train of multiplying wheels, the first of which is moved by the bar whose elongation is to be measured, while the teeth of the last engage with the threads of an endless screw whose axis is vertical, and carries at its extremity a long index moving over a graduated circle. The multiplying power of the instrument is very great; its defects are its want of steadiness, great internal strain, and the difficulty of bringing the index back to zero when the pressure on the lever connected with the first wheel is removed.—Prof. Foster, F.R.S., made a communication on the geometrical treatment of certain elementary electrical problems. The object of this communication was to illustrate the facility and clearness by which certain of the electrical problems occurring in elementary instruction could be treated by easy geometrical methods. Its application was shown in the following cases: 1. The calculation of the quantity of heat evolved in a galvanic circuit; the calculation of the electromotive force and of the permanent resistance of a voltaic battery from two deflections of a tangent-galvanometer; the determination of the joint resistance of several conductors combined in multiple-arc; and the determination of the distribution of potential and strength of the currents formed by connecting the similar poles of two unequal batteries with the opposite ends of the same conductor.—Prof. Guthrie read a paper on salt solutions and water of crystallisation. The absorption of heat which occurs when a salt is dissolved in a liquid was shown to depend not only on the relative specific heats of the salt and the liquid, but also on the molecular ratio of the resulting solution. This ratio declared itself optically (1) by the singularity of the refractive index when the critical ratio was obtained, (2) by the singularity of density at the same point, (3) by the heat absorbed when (a) a saturated solution was mixed with the medium, and (b) when the salt itself was dissolved in a certain quantity of the medium. The condition of maximum density of water was referred to the existence of a definite hydrate of water. It was shown that every salt soluble in water was capable of uniting with water in a definite ratio (by weight), forming definite solid compounds of distinct crystalline form and constant melting and solidifying points. It was supposed that the ratios of such union are not incommensurable with the ratios of chemical weight, and that the new class of bodies which only exist below

o° C., and may be called *cryohydrates*, are not discontinuous with the hydrated crystalline salts previously known. A few cryohydrates were described as being obtained from the saturated aqueous solutions of the respective salts on the withdrawal of heat. Thus chloride of sodium combines with 10.5 (210) molecules of water, and solidifies therewith at - 23° C. Chloride of ammonium combines with 12 molecules of water, and solidifies at - 15° C. The combinations with water were given of the sulphates of zinc, copper sodium, and magnesium, also those of the nitrates of potassium, chlorate of potassium, and bichromate of potassium. As far as experimental results at present indicate, it appears that these cryohydrates which have the lowest solidifying point have the least water. Some suggestions were offered concerning the application of these experimental results to the explanation of the separation of the Plutonic rocks from one another, and the importance was pointed out of the use which these cryohydrates will have in establishing constant temperatures below o° as fixed and as readily obtainable as o° itself.

**Mathematical Society, Nov. 12.**—Dr. Hirst, F.R.S., president, in the chair.—The President informed the meeting of the loss the Society had sustained by the recent death of one of its honorary foreign members, Dr. Otto Hesse, of the Polytechnicum, Munich, and mentioned that it was the intention of the Council soon to fill up the vacancies caused by the deaths of Drs. Clebsch and Hesse.—On the motion of Prof. Cayley, F.R.S., seconded by the Rev. R. Harley, F.R.S., it was ordered that the cordial thanks of the Society be presented to Lord Rayleigh for his munificent donation of 1,000*l.* to the Society, and the chairman was requested to convey the same by letter to his lordship.—The money has been vested, as the treasurer's report mentioned, in 870*l.* Guaranteed Indian Railway Stock, and the interest will be applied, as was stated two or three months since in NATURE, to the purchase of mathematical journals, and also to assist in defraying the expense of printing the Society's Proceedings. The meeting then proceeded to the election of the new Council, and the gentlemen whose names were given in a recent number of this journal were declared by the scrutators to be duly elected.—Instead of giving the usual valedictory address, Dr. Hirst stated what results he had arrived at in the course of his investigations upon "Correlation in Space." The communication was an extension to space of results arrived at in his paper (read before the Society in May last), entitled the "Correlation of Two Planes."—Mr. J. H. Röhrl read an abstract of a communication on "Tidal Retardation." The problem discussed is the superior limit to the tidal retardation in a globe, in all respects similar to our own, except that it is covered entirely by a sea, the depth of which is constant for all places in the same latitude, and is therefore a function of latitude only—not longitude—a function supposed to be known.—A paper by Prof. Wöstenholme on a new view of the porism of the in- and circumscribed triangle was taken as read.

**Anthropological Institute, Nov. 10.**—Prof. Busk, F.R.S., president, in the chair.—Reports were read by Mr. F. W. Rudler on the Anthropological Department of the British Association at Belfast, and by Mr. Hyde Clarke on the Anthropological Section of the International Congress of Orientalists recently held in London.—A paper was then read by Col. Lane Fox on a series of flint and chert arrow-heads and flakes from the Rio Negro, Patagonia, with some remarks on the stability of form observable in stone implements. The series of specimens exhibited was selected from a collection of 500 gathered by Mr. W. H. Hudson on the margin of the river and over an extent of about ninety miles, and on the numerous lagoons, now mostly dry, with which the valley is everywhere intersected. The valleys in that region run through high-terraced table-lands; and on the plateaus above there is no water and but very scanty vegetation, which would seem to indicate the improbability of their having been occupied by man. A great number of the implements were discovered by Mr. Hudson on the sites of villages in the valley and in circular flattened mounds of clay measuring from 6 ft. to 8 ft. in circumference. The different styles of workmanship observed in the different villages were not, in the opinion of Mr. Hudson, to be attributed to the variety of material employed, but to the degree of skill possessed by the inhabitants of each village. The author drew attention to the interesting fact of the arrow-heads having long fallen into disuse among the Tehuelches and other Patagonian tribes, who now and for some centuries past employed the spear. Col. Fox proceeded to describe in detail the various weapons and their varieties of workmanship, and showed that they all presented the same general features as

implements found in the United States. He believed that, owing to our inability to understand the uncultured mental condition of savages and prehistoric races, we often lose sight of the inferences deducible from the stability of form observable in their arts and implements, and attach less importance than should be the case to minute varieties of structure.—It was announced that the Council had resolved to publish in the Journal of the Institute bibliographical notices, abstracts and reviews of English and foreign works and papers, and other miscellaneous matter of anthropological interest and importance.

PARIS

**Academy of Sciences, Nov. 2.**—M. Bertrand in the chair.—The following papers were read:—General results of observations on the germination and first developments of different lilies, by M. P. Duchartre.—Researches on the dissociation of crystalline salts, by MM. P. A. Favre and C. A. Valsou.—Results of the voyage of exploration undertaken for the preliminary study of the general track of a railway connecting the Anglo-Indian with the railways of Russian Asia, by M. F. de Lesseps.—Rational treatment of pulmonary phthisis, by M. P. de Pietra Santa.—On new apparatus for studying the phenomena of the combustion of powders, by MM. Marcel-Deprez and H. Sebert.—Theory of electro-dynamics freed from all hypotheses relating to the mutual action of two current elements, by M. P. Le Cordier.—Monograph of the anguilliform family of fishes, by M. C. Daresse.—On the existence of a sexual generation in *Phylloxera vastatrix*, by M. G. Balbiani.—On the solution of numerical equations of which all the roots are real, by M. Laguerre.—On an apparatus for determining personal equations in observations of the transit of stars, arranged for the geodesic service of the United States, by MM. Hilgard and Suess.—On the laws of the vibratory motion of tuning-forks, by M. E. Mercadier.—Note on a modification of Fehling's and Barreswil's solutions for the determination of glucose, by M. P. Lagrange.—On the fermentation of fruits, by MM. G. Lechartier and F. Bellamy. The authors have now examined the products from cherries, gooseberries, and figs.—Application of the graphical method to the study of certain points in deglutition, by M. S. Arloing. The author concludes from his experiments that a decided difference exists between the swallowing of liquids and of solids.—On the mechanism of deglutition, by M. G. Carlet.—Results furnished by surgical operations performed on patients in which anaesthesia has been produced by the intravenous injection of chloral, by M. Orlé.—Note on a cyclone observed at La Pouzée (Maine-et-Loire) Sept. 30, 1874, at 4.30 P.M., by M. Al. Jeanjen.—The Report of the Commission appointed on August 17 for preparing a reply to the letter addressed by the Minister of Public Instruction concerning the organisation of a Physical Astronomical Observatory in the neighbourhood of Paris, was read at the conclusion of the meeting.

BOOKS RECEIVED

- BRITISH.—Meteorological Committee (her Majesty's Stationery Office).—Beauty in Common Things, by the author of "Life Underground" (Society for the Promotion of Christian Knowledge).
- AMERICAN.—Monthly Report of Department of Agriculture, October 1874 (Washington, U.S.).
- COLONIAL.—Red Corpuscles of the Blood: R. H. Bakewell, M.D. (Mills, Dick, and Co., Otago, N.Z.).—Centrifugal Force and Gravitation: John Hart (John Lovell, Melbourne).—Fossiliferous of the Paleontology of Victoria (Australia): John Ferris (Melbourne).

CONTENTS

	PAGE
ELIE DE BEAUMONT. By Prof. AICH. GEIKIE, F.R.S.	41
FLUORINE AND HANDBURY'S "PHARMACOGRAPHIA." By HENRY P. BREADY, F.R.S.	42
SULLY'S "SENSATION AND INTUITION." By DOUGLAS A. SPALDING.	44
LETTERS TO THE EDITOR.—	
Sounding and Sensitive Flames, II.—Prof A. S. HERSCHEL (With Illustration)	45
Insects and Colour in Flowers.—THOMAS COMBER	47
Drosere.—REV. G. H. HOPKINS	47
Suicide of Scorpions	47
The Cry of the Common Frog	48
Phylloxera VASSETZII.—A. HARWOOD	48
A Nest of Young Fish.—ROBERT W. S. MITCHELL	48
THE DEVELOPMENT OF MOLLUSCA	48
ON MIRAGE. By Prof. J. D. EVERETT, D.C.L. (With Illustrations).	49
SOME REMARKS ON DALTON'S FIRST TABLE OF ATOMIC WEIGHTS. By Prof. H. E. ROSCOE, F.R.S.	52
INTERNATIONAL METRIC COMMISSION AT PARIS. By H. W. CHISHOLM, Warden of the Standards	54
NOTES	55
SOCIETIES AND ACADEMIES	55
BOOKS RECEIVED	60

THURSDAY, NOVEMBER 26, 1874

## THE ENGLISH ARCTIC EXPEDITION

HER Majesty's advisers can by no means be accused of precipitancy in the decision they have recently come to, to send out a new Arctic Expedition; they have certainly waited for "the fulness of the time," which, for the lay mind, may be said only to have been accomplished with the return of the Payer-Weyprecht expedition. We believe that the scientific societies of the country had good grounds for urging upon Government the propriety of fitting out an expedition for Arctic discovery years ago; all who understand the Arctic question, we are sure, will coincide with us in the opinion, that had energetic measures been taken when the subject was first urged upon the attention of Government, the earth's surface around the North Pole would by this time have been on our maps. Still, Government cannot be blamed for this tardiness; it cannot be expected that men who have no occasion to make a special study of scientific questions can see them in the same light as those whose great work in life is scientific investigation; and, moreover, in a country governed as ours is, Ministers, before coming to a decision on any important matter, are bound carefully to feel the country's pulse, not to mention their duty in respect of the country's purse. Her Majesty's advisers have, then, no doubt been, from their point of view, wise in deferring till now their decision that England should once more come "to the front in the exploration of the unknown "Polynia;" as they also would have shown themselves extremely unwise and unable to read the country's wishes had they postponed the matter any longer.

That the Ministry have rightly divined the general wish in reference to the part which England should play in Arctic exploration is evident from the all but unanimous approval with which their decision has been met by the press. The unaccountable roar—undignified howl, we had almost said—which, either too late or too soon, fell from the (evidently, in this case, ill-informed) "leading organ," need not be made much of. It was evidently not the result of a candid and comprehensive consideration of the whole question by one competent to decide. Were the objections so bitterly uttered by the *Times* against Arctic exploration to have force, they would equally hold against all abstract scientific investigation whatever, and indeed against all work not undertaken for the lust of gold. Happily, however, it is long since the race has become convinced that "man cannot live by bread alone," and that there is a hunger that will never be appeased so long as a shred of mystery hangs to this earth of ours and to the mighty universe of which it forms part; and there is no danger of man's noblest appetite becoming extinct for lack of material to feed upon. But, indeed, the *Times* article is a puzzling one; it is so inconsistent with its opinions on questions of a similar kind, and with its advanced opinions on scientific questions generally.

As to the propriety of Government undertaking the organisation of an Arctic expedition, we have said so much already on this subject, both directly when the subject was formerly before the public, and indirectly in

connection with the advancement of scientific research, that we need not refer to it here again. That any but a Government expedition under naval discipline is inadequate for the work of thorough polar exploration has been practically proved over and over again; what can be accomplished by an expedition so organised, under comparatively favourable circumstances, may be seen in the valuable work already achieved by H.M.S. *Challenger*. For similar reasons, we need not refer to the many important advantages to science, and therefore to mankind, which are certain to result from a thorough exploration of the regions and the terrestrial conditions around the pole. For one thing, it is scarcely any exaggeration to say that all the civilised world is looking to Britain for the final unravelling of the Arctic mystery, to complete the work which has already added so considerably to the general sum of her glory: witness Dr. Petermann's letter, vol. xi. p. 39:—

"I do not know," Petermann says, "the views held in England now, but I know that to us outsiders the achievements and work of a man like Sir James Clarke Ross or Livingstone have done more for the prestige of Great Britain than a march to Coomassie, that cost nine millions of pounds sterling. That great explorer, Livingstone, is no more; his work is going to be continued and finished by German and American explorers; we shall also certainly not let the Arctic work rest till it is fully accomplished, but it surely behoves Great Britain now to step in and once more to take the lead."

How keenly the resolution of the Cabinet has been appreciated by naval and scientific men, is shown by the number of competent volunteers which have already come forward for the expedition; so many, indeed, as to make the task of selecting embarrassing; so far as suitable men are concerned, a dozen Arctic expeditions might be efficiently fitted out.

As to the route, herein also has the Government shown its discernment; there can be no doubt that any expedition, one of whose objects is to attempt to reach the pole, is shut up to adopt the Smith's Sound route. Capt. Koldewey's work in 1869-70 proved finally the impossibility of penetrating to the pole between Greenland and Spitzbergen; the recently returned Austro-Hungarian expedition proves that the task is equally hopeless on the Novaya Zemlya side of Spitzbergen; Behring Strait is out of the question. Thus the demonstration that the route by which the *Polaris* accomplished so much is the gateway to the pole, has been completed by the attempt of the Payer-Weyprecht expedition; and thus, no doubt, the Government has shown considerable prudence in delaying its decision until the data were complete, as well as its generous readiness to step in at the right moment. As we said last week, now that the expedition has been decided on, its equipment will be carried out on a thoroughly liberal scale. A note this week tells what has been done by Sir Leopold M'Clintock as to the selection of the vessels which are to carry the expedition, and, as we learn from an evidently authoritative article in Saturday's *Daily News*, the strength of the expedition will probably consist of from 100 to 120 officers and men. Preparations have been already begun, and as the expedition will probably not sail till the month of May next year, we may expect that it will leave our shores more perfectly equipped in every respect than any expedition that has hitherto sailed to the same quarter of



the globe; what Government will do when it takes such work in hand, we have a good example of in the *Challenger* expedition.

There is now such a vast stock of experience in Arctic exploration from which to derive lessons for guidance as to the equipment of the new expedition, that we have every assurance the new expedition will be organised in such a manner as to secure the maximum of efficiency with the minimum of danger and discomfort. But, indeed, Mr. Markham has clearly proved, in his "Threshold of the Unknown Region," that the cry of danger has no foundation whatever, and his statement is only confirmed by the three most recent and by no means adequately equipped expeditions, those of the *Polaris*, the *Germania-Hansa*, and the *Tegelhof*.

It is calculated that the expedition will cost about 30,000*l.* a year, "which," as the *Daily News* justly says, "is surely a very moderate expenditure for an object so important. The officers and men of the expedition will belong exclusively to the Royal Navy; the former will be selected for their scientific qualifications, and will at once enter on the study of the special subject, a knowledge of which the purposes of the expedition demand." No doubt, then, every branch of science on which exploration near the pole of the earth is likely to throw light will have a competent representative on the staff; and here we would urge upon the organisers the great importance of the spectroscopic examination of the aurora in those regions where often it can be studied almost nightly; no doubt there will be some competent man on board to look after this investigation.

From this expedition, then, entered on after the most mature deliberation, and likely to be organised on the most liberal basis, science may expect to reap a rich harvest. To quote the concluding words of the article already referred to: "As the object of the expedition is not merely to reach the pole, there will be no hurried racing to attain that point. The whole phenomena of the polar area is of deep and still mysterious interest. The opportunity now is within reach to lay open to the scientific world a mass of invaluable data relating to the region which lies concealed behind the 80th parallel of latitude and within an area of two million square miles. It may be shown that no such extent of unknown area in any part of the world ever failed to yield results of practical as well as of purely scientific value; and it may be safely urged that, as it is mathematically certain that the area exists, it is impossible that its examination can fail to add largely to the sum of human knowledge."

#### OBSTACLES TO SCIENTIFIC RESEARCH

SOME remarks with which Prof. M'Nab prefaces a paper "On the Movements of Water in Plants," recently published in the Transactions of the Royal Irish Academy, deserve serious consideration as an instance of the obstacles which exist in the way of scientific research in this country quite apart from the personal difficulties of those who may wish to engage in it. He complains that "the chief difficulty I have had to contend with has been the impossibility of obtaining in Dublin, in the same locality, the two essentials for experimenting, namely, a laboratory and a botanical garden. The appliances of a

chemical laboratory must be within easy reach of the plants to be experimented on; if not, then errors are sure to be made; and as much time would necessarily elapse between procuring the plant for experiment and the commencement of the experiment itself, the results obtained would certainly be untrustworthy. In fact, the nearer the plants are to the laboratory the better; the results will be more accurate, and the experiments much more easily performed. . . . A large number of most interesting and valuable experiments might be made if only a few pieces of apparatus could be placed near the plants to be experimented on. A balance, a water-oven, spectroscope, and the like, are essential; while the few chemicals and small pieces of apparatus could easily be had. There can be little doubt that the reason why so few physiological experiments are made in this country is to be looked for in the absence of the necessary laboratory accommodation near our gardens. In Germany and France the agricultural stations supply most of the researches in vegetable physiology. Here, however, all depends on private enterprise; and when there is an observer capable of undertaking experiments, he may not be willing to incur the expense of supplying plants and apparatus."

At the present time there is no place in the whole country where facilities for investigations in Physiological Botany are in any way afforded. Even Vegetable Chemistry is confined to the laboratories at Cirencester and Rothamstead, both private property and with a scope somewhat limited by their immediate relation to agriculture. Besides these it would be hard to mention, even in the whole British Empire, any other place where this kind of research is carried on, unless we except the Government manufactory of cinchona alkaloids under Mr. Broughton's charge on the Nilghiris, which has yielded, incidentally, new information on many interesting points. It is true that the Science Commission has reported in favour of opportunities for the pursuit of investigations in Physiological Botany being afforded in the Royal Gardens at Kew. But there seems but faint hope of anything of the kind being done—or in any adequate way. Even the action of our Universities, munificent as it has been in some directions, has been reactionary in this. As long as Dr. Daubeny was Professor of Botany at Oxford, the small chemical laboratory belonging to Magdalen College, adjacent to the Botanical Garden, was available for purposes of research of this kind. Now it is separated altogether, and used for purposes of college instruction. And it may be added that this laboratory will always be a classical spot as having been the place where the first researches on the relation of light of different degrees of refrangibility to the elimination of oxygen from tissues containing chlorophyll were carried on. Hunt, Draper, and Sachs have arrived at a better knowledge of the subject, but Daubeny was able to show first that the effect is principally due to the influence of rays in the neighbourhood of the yellow portion of the spectrum, and that those of higher refrangibility are practically destitute of any influence in the matter—a result, even now, that it is firmly established far indeed from being *à priori* explicable.

So much has now been clearly worked out in respect to the physical details of the "vital" processes of plants,



that it would be eminently desirable to have in each of our older universities the very simple and moderate accommodation attached to their botanic gardens which is needed, if only for giving students an opportunity of going over for themselves biological phenomena so fundamental in their general character and so comparatively easy to investigate.

### THE SECOND GERMAN ARCTIC EXPEDITION

*The German Arctic Expedition in 1869-70, and Narrative of the Wreck of the "Hansa" in the Ice.* By Capt. Koldewey, Commander of the Expedition, assisted by members of the Scientific Staff. With numerous Woodcuts, two Coloured Maps, two Portraits on Steel, and four Chromolithographic Illustrations. Translated and Abridged by the Rev. L. Mercier, M.A. Oxon; and edited by H. W. Bates, F.L.S., Assistant Secretary, R.G.S. (London: Sampson Low and Co., 1874.)

THIS well-told and extremely interesting narrative of the fruitful German expedition to East Greenland in 1869-70 strongly confirms what we have said in our leading article with regard to the necessity of Government undertaking arctic exploration in order that it may be carried on with the greatest efficiency, the wisdom of choosing the route by Smith's Sound, and the valuable results that may be looked for from an expedition organised on a broad and liberal basis and carried out in a thoroughly systematic manner.

This expedition was initiated at Bremen shortly after the return of the first German Arctic Expedition, by Dr. Petermann, Capt. Koldewey, and a few others who are eager to advance the exploration of the polar regions, the object being to penetrate into the still unknown heart of these regions, making the east coast of Greenland the basis of operations. An elaborate plan of exploration was drawn out, which included the solution of nearly all the questions with respect to the arctic regions that yet remain unsolved. The funds were to be raised by public subscription, and the large committee of eminent scientific men who undertook the organisation of the expedition worked enthusiastically to get it set afloat. The scheme was well received by the German public. It was calculated that the whole expenses of the expedition would amount to 10,500*l.*, and we are glad to see that all this was obtained, and even additional expenses paid off after the return of the expedition.

As might be surmised, this sum was adequate for only a modest expedition; it is calculated that our Government expedition will cost at least six times that amount. Two small vessels were procured to carry the members of the expedition, the *Germania* and *Hansa*, the latter to act as tender to the former. The *Germania* was built expressly for the purpose, was a small two-masted screw steamer of 143 tons burden, thoroughly well sheathed and adapted for ice-navigation; for a ship of its size, indeed, it could hardly have been better fitted than it was to struggle with all the dangers of ice-navigation. The *Hansa* was a schooner of 76½ tons burden, which had been built in 1864; as she was to act as tender to the *Germania*, she does not seem to have been so strongly armed as the

latter. The internal fittings, provisioning, and general equipment were all that could be desired, considering the modest sum with which the organisers had to work.

The commander of the expedition was Capt. Koldewey, thirty-two years of age, an experienced arctic navigator and an enthusiast for arctic exploration, who by scientific study had added to his practical qualifications for the command of such an expedition; Capt. Hegemann ruled on board the *Hansa*. The narrative of the expedition contains a brief sketch of the career of each of the scientific members of the expedition, all of whom seem to have been well qualified for their particular work. Physics, astronomy, botany, zoology, geology, and geodesy each had its representative, and on the whole we are bound to say the interests of each department were well cared for. One of the most efficient and hardest working members of the expedition was Lieut. Julius Payer, then twenty-seven years old, and how so famous in connection with the successful Austro-Hungarian expedition. There was an Englishman on board, Dr. Copeland, who, along with Dr. Börgen, undertook astronomical and physical science, as well as geodesy. Dr. Pansch was well qualified to look after the botany; and Prof. Dr. Laube, of Vienna, was zoologist on board the unfortunate *Hansa*. Still, the narrative must forcibly impress any careful reader with the idea that the scientific staff was far from adequate for the work of thorough arctic exploration; officers and men worked heart and soul to carry out the objects of the expedition, and the results obtained are well worth the money expended; but at almost every step it was evident that the work was greatly hampered for want of men.

The two ships, with well-assorted staffs and crews, left Bremerhaven on June 15, 1869, in presence of his Majesty the King of Prussia, who showed the warmest interest in the expedition. They went joyously on their journey, everyone on board in excellent spirits, the scientific staff making what observations were possible on the life and temperature in sea and air. This part of the narrative, as indeed the whole story of the expedition, is told with a most charming simplicity and freshness, which has been well kept up in the English abridged translation. The solitary and rugged Jan Mayen was sighted on July 9, but the almost eternal mist forbade any attempt at landing. Both *Germania* and *Hansa* struck the ice on July 15, the former in 74° 47' N. lat. and 11° 50' W. long., and the latter in 74° 57' N. and 9° 41' W. The two ships had lost sight of each other on July 10, and did not meet again till the 18th, keeping in sight of each other among the ice till the 20th. On that day the *Germania* signalled to the *Hansa* to come within hail, which unfortunately Capt. Hegemann misunderstood, and kept further off; the two ships did not meet again. Up to this time they had been sailing northwards, mostly in dense fogs, trying to find an opening through which they might penetrate through the ice-line, so as to get as near the land as possible. As no favourable opening could be found, the ships turned southwards, agreeing to meet at Sabine Island. Shortly after the *Hansa* got caught among the ice, with which she continued to struggle heavily, and by August 14 was hopelessly involved in the impenetrable masses. From this time she was at the mercy of the ice, with which she drifted south until Oct. 21, when, in 70° 52' N. and 21° W., she was crushed between the heavy

floes and sank. Happily, those on board had for some time before begun to fear the worst, and transferred from the *Hansa* to a large floe a considerable proportion of the movables on board, including three good boats. They were, indeed, more fortunate than the nineteen people belonging to the *Polaris*, who found themselves in a similar position, very inadequately provided for. The men of the unfortunate *Hansa* proceeded to make themselves as comfortable as possible on their drifting island of ice, which at first was about seven miles in circumference. Among the stores which were transferred to the ice was a large quantity of coal in well-squared blocks, with which a wonderfully comfortable house was built, surrounded by a sort of snow wall, the space between which and the

house was covered over. The story of the life of the *Hansa's* crew on their drifting floe is very well told; and although of course they were not quite so comfortable as if they were sailing in a good ship on a sunny sea, still their hardships appear to have been by no means great—not so great, we think, as those which the officers and crew of the *Germania* had to undergo in carrying on the work of the expedition. No one seems to have been seriously affected in health by the journey, and all kept in wonderfully good spirits. The floe occasionally came to grief, and its dimensions became gradually diminished; in January it suffered such a terrible break-up that a new house had to be built. Neither officers nor men—fifteen in all—gave themselves



FIG. 1.—Regenerated Glacier in Franz-Joseph's Fjord.

up to idleness; observations were being continually made, and this part of the narrative will be found to contain a good deal of valuable information as to [the fauna and flora met with, the state of the ice, the currents, and on the geographical and geological features of the land. At last, on May 7, in  $61^{\circ} 12' N.$ , the company quitted the floe and took to the boats, after having been on the former for 200 days. Even then it was not all plain sailing, as they had often to stay for days on floes, dragging the boats after them. At last, however, they got fairly away, and on June 13 reached the Mission Station of Friedericksthal, near the south point of Greenland, in  $60^{\circ} N.$  lat., eight months after their little ship went down about 700 miles further north. It is needless to say the fifteen men were most hospitably entertained by the good missionaries.

After staying here a short time they went by Lichtenau to Julienshaab, a town further up the west coast of Greenland. Here they were taken on board a ship bound for Copenhagen, which, after visiting Fredericksshaab, still further north, started for Europe about the end of July, and landed them in Copenhagen on Sept. 1. During the stay of the *Hansa's* crew in the south-west of Greenland, the officers made many valuable observations on the people and the geology of the country. The natives in these parts are very different in *physique* from those on the west coast, as well as from those who live much further to the north; they bear on their features the unmistakable marks of a large infusion of European, mainly Danish, blood, and in their habits they are altogether more civilised than the genuine aborigines. Dr. Laube

was indefatigable in his investigations on all points of scientific interest, and geographers and antiquaries will be delighted with the latest information respecting the remains of the first Norse colonists, the European discoverers of Greenland; an illustration is given of what are supposed to be the ruins of Erik Randa's house.

It would be impossible, within the limits of a review, to give any adequate idea of the work of the more fortunate *Germania*. After sailing about among the ice till the 5th of August, she dropped anchor in a small bay on the south of Sabine Island, in about  $74\frac{1}{2}^{\circ}$  N., which was ultimately to be her winter harbour. From here an attempt was made to advance northwards, but the task was given up as hopeless, after repeated attempts and the most anxious observation and consultation, and the *Germania*

never got further north than  $75\frac{1}{2}^{\circ}$ . The ship returned to its first anchorage on the south side of Sabine Island, where she remained from Sept. 13, 1869, to July 22, 1870. The position chosen was a well sheltered one, both on the north and south, and although subjected to fearful storms the stout little steamer bravely weathered the long winter, and left Greenland with nothing wrong but a leaky boiler. The officers and crew seem to have been as comfortable as they could be on board a ship of the *Germania's* accommodation, and nearly the whole winter through they were kept pretty regularly supplied with fresh meat, as the district around abounds with musk-oxen, reindeer, hares, foxes, not to mention seals, fish, and feathered fauna. An observatory was established on shore, and a valuable series of meteorological and magnetic observa-



FIG. 2.—Group of Esquimaux.

tions made, as well as observations on the tides and currents. Several sledge journeys were organised in autumn, spring, and summer; and notwithstanding the great hardships from which those who went on these journeys suffered, from insufficient sledges, want of draught dogs, inadequate shelter, insufficient food, and generally deficient equipment, as well as from the wretched state of the ground, so unfavourable to sledge travelling, a wonderful amount of scientific work was accomplished between Cape Bismark on the north, a little south of the 77th parallel, and the magnificent inlet discovered by the expedition, which indents the coast a little north of  $73^{\circ}$ , and which has been named Kaiser Franz-Joseph's Fjord. Anyone who compares the map of this stretch of coast which accompanies the volume with previous maps of Greenland will see at once

that our geographical knowledge of the East Greenland coast has been largely added to as well as corrected by the expedition. The mountain scenery and glaciers of this stretch of coast are very grand, and attain almost Alpine dimensions and magnificence in the many-armed Franz-Joseph Fjord. Lieut. Payer gives an admirable account of the scenery, geology, and glacial features of the latter, which is well helped out by the engravings and chromolithographs that illustrate his account. One peak, "a pyramid of ice," Payer calls it, rising 11,000 ft. above the sea far to the west of the Fjord, was named after the accomplished geographer Petermann.

But we cannot enter into details. Botanists will find plenty to interest them in these pages, as a very full account is given of the almost incredibly abundant flora of the region; a whole chapter is devoted to an

account of the habits and appearance of the larger fauna, which is so plentiful that no expedition need suffer from want of food; the geology of the coast and islands was well investigated, and coal was found to abound in some districts; dredging also was occasionally carried on, but with no very fruitful results. Clavering, forty years ago, met with a considerable number of natives in this part of East Greenland; not one is now to be found, though the remains of their huts, burial-places, weapons, and utensils abound. The map shows that careful and frequent soundings were taken, and the book contains some very valuable observations on the nature of the ice of these regions, and especially on the difference between the Greenland glaciers and those of the Alps. We find also that a spectroscopic examination was made of the deep blue light of the ice, the result of which is, however, not given. Indeed, those who want to obtain full details of the scientific results of this expedition must go to the original German account, as the English edition has evidently been mainly abridged by the omission of scientific details.

Altogether, the results of the second German Arctic Expedition are such as to reflect the very highest credit upon its members, and must be very gratifying to its promoters. There is yet much to be done ere the east coast of Greenland is adequately explored, and although this expedition has clearly proved that there is no road to the pole from that side, still there is undoubtedly on the east coast of Greenland a fertile field for further discovery. All this is admitted by Capt. Koldewey in his conclusion, and we coincide with him in believing that if an English expedition to West Greenland through Smith's Sound, and a German one to East Greenland, started at the same time, they would, with our present experience and means of assistance, certainly lead to very rich results. Happily, an English expedition on an adequate scale is being organised; let the German Government emulate the liberality of ours, and send out an equally well-equipped expedition, to continue, if not to complete, the work of the *Germania* on the other side of Greenland. If it so please the Germans, let it be a race to the pole, and let Dr. Petermann be umpire.

The *Germania* left her winter-quarters on July 22, and after coasting about for some time—it was then the large Fjord was discovered—turned homewards, and reached Bremerhaven safely on Sept. 11.

The translation and editing are carefully done, and the numerous and well-executed illustrations add greatly to the value of the work, which well deserves a wide circulation.

#### DRAYSON'S "PROPER MOTION OF THE FIXED STARS," ETC.

*The Cause of the Supposed Proper Motion of the Fixed Stars, and an Explanation of the Apparent Acceleration of the Moon's Mean Motion; with other Geometrical Problems in Astronomy hitherto Unsolved. A Sequel to the Glacial Epoch.* By Lieut.-Col. Drayson, R.A., F.R.A.S. (London: Chapman and Hall, 1874.)

THIS book, the author tells us, is a sequel to "The Cause, Date, and Duration of the Last Glacial Epoch," of which we published a short notice last year. The last work was founded on misconception and igno-

rance, and in this respect the one may fairly be called a sequel to the other. In our remarks on "The Glacial Epoch" we objected to the author's attempt to solve a problem in physical astronomy by geometry alone. The author, however, is unconvinced. His geometry, it is true, is a much more powerful instrument than anything of the same name which we have had the fortune to meet with so far. On p. 4 of the present work he thus compares the powers of observation and geometry:—"Mere observation can never arrive at any result until the whole cycle, and perhaps many cycles, have been observed. For example, if the sun's mid-day altitude were observed on the 1st of January of any year, and again on the 1st of February and 1st of March, observation alone could tell us nothing more than that there was a certain increase in this meridian altitude. Geometry, however, could analyse this rate of increase, and would probably be able to predict what would be the sun's meridian altitude for every day in the year." Perhaps the author could, by his geometry, if he knew the height of the reviewer at the ages of ten, twelve, and fourteen, predict his height at the age of fifty or sixty. The geometry which could solve the one problem would surely be able to solve the other.

Lieut.-Col. Drayson is not only unconvinced; he is unblushingly self-confident. On p. 33 we find: "When, then, it happens that the number of persons capable of judging independently of an original and difficult problem in geometrical astronomy, are to the number who are the mere blind followers of 'authorities in science' as about one to ten thousand, we find ourselves in a considerable minority."

On the other hand, the amount of reliance which he places upon the intelligence of other persons is very slight, as may be seen from the following quotations:—

"To a person unacquainted with geometry there seems nothing unsound in stating that the centre of a circle can vary its distance from the circumference and yet still always remain the centre; and this is the statement now put forward as correct by certain theorists."

"In our work, 'The Cause, &c., of the Glacial Epoch,' we called attention to the fact that it seemed improbable that the centre of a circle could vary its distance from its circumference and yet remain the centre, although it had been agreed during nearly two hundred years that it could do so."

Of course it would seem unsound, improbable, impossible, and absurd to anyone who had formed his ideas of a circle from Euclid's definition; and to us it seems almost inconceivable that anyone can really believe or profess to believe, what the author here and in almost innumerable other passages in his books so confidently asserts, that this absurdity is taught or even thought of. The author certainly never proves that such is the case. The special views of Lieut.-Col. Drayson with reference to the movement of the axis of the earth in space we will let him state for himself:—

"It is here demonstrated that during 230 years we can calculate what the obliquity was to within one second; that is to say, the actual curve traced by the pole of the heavens relative to the pole of the ecliptic during 230 years does not differ one second from the circumference of a circle having a radius of  $29^{\circ} 25' 47''$ , and its centre  $6^{\circ}$  from the pole of the ecliptic. In other words, the curve traced by the pole of the heavens during 230 years is part of a circle such as that defined above."

On the previous page we find his opinion of his own exploit, for he there tells us: "This calculation is, perhaps, the most rigid geometrical investigation that has ever been applied to an astronomical problem."

Perhaps our readers will scarcely credit the statement that, notwithstanding this proud confident boasting, there is no investigation at all. All the author does is to draw a circle, which of course he can draw through three points, which are different positions of the earth's pole, and then, because his circle always passes within one second of the different positions of the pole for a couple of hundred years, we are asked to take it as proved that the pole always has been and always must be on this circle.

The extreme proximity of two curves for a comparatively short distance is no criterion of their being coincident.

The author, in the preface to this work, makes some strictures on our remarks on "The Glacial Epoch." In these he mistakes our illustrations for arguments, misquotes our objections, and misstates our arguments. It is impossible to reply, and it is perhaps as well; we have already given too much space to this author.

### OUR BOOK SHELF

*Degli Studi Fisici di Ambrogio Fusinieri: Commemorazione per Enrico dal Pozzo di Mombello, Professore di Fisica nell' Università Libera di Perugia.* (Foligno, 1874.)

THIS dry little book gives an account of the works of Fusinieri which related chiefly to endosmose, capillarity, adhesion, and other molecular actions; also to static electricity and to magnetism. He published a work in 1844 on "Molecular Mechanics, and a Repulsive Force in the Etheral Medium," which we have never seen, but which would surely be of interest now in connection with Mr. Crookes's experiments on repulsion by heat in a vacuum; in 1846, a memoir on Light, Heat, Electricity, Magnetism, and Electro-magnetism; in the following year a memoir on Meteorology; and altogether many small occasional memoirs. The second part of Prof. dal Pozzo's work is a critical inquiry into the work entitled "The Unity of the Physical Forces," published in 1864 in Rome by Father Secchi; and the third part contains some biographical notices of Fusinieri. The book is unillustrated, and has no felicities of style to recommend it; the students of the Free University of Perugia must be devoted scientists if they purchase the book and manage to read from beginning to end of it.

### LETTERS TO THE EDITOR

[The Editor does not hold himself responsible for opinions expressed by his correspondents. Neither can he undertake to return, or to correspond with the writers of, rejected manuscripts. No notice is taken of anonymous communications.]

#### Royal Agricultural Society and the Potato Disease

THE paragraph which appeared in your last week's issue is so far interesting that it amply confirms the expectations of those who have watched the well-meant efforts of the Royal Agricultural Society with respect to the potato disease. I wish to advert to it for two reasons. In the first place, it is interesting to see the way in which a matter of this kind is regarded by so influential a body. Here is a disease annually effecting the destruction of a larger or smaller part of a chief item in the food of the community, which has already produced a famine in one of the three kingdoms, and any year may produce another, and which for the last thirty years has seriously occupied the atten-

tion of scientific men throughout Europe. Is it not surprising that the Royal Agricultural Society should think the offer of a *root* prize for an essay in any way an adequate method of dealing with the subject? In the first instance, the time for sending in the essays was actually fixed so as to prevent the competitors from even going over the life history of the fungus during one season before competing. This was pointed out, and the time was prolonged. But though the competition was advertised abroad in the German papers, nothing of any importance was elicited beyond what was already well known.

The Society then determined to offer prizes for disease-proof potatoes. The utter futility of this proceeding was clearly obvious to anyone in the least acquainted with the subject. But it was done, and possibly if the "botanic referee" liked travelling about the three kingdoms, his time was not wasted. But the result is exactly what it was predicted it would be.

Now, it seems to me that this spasmodic and ill-considered way of dealing with a serious subject contrasts, to an extent that it is impossible quite to regard with satisfaction, with the course that would be adopted in such a matter in other countries. It shows, at any rate, how little the methodical scientific method of investigation is understood by the majority of well-informed English people.

And this brings me to my second point. The Society, anxious not to be entirely foiled, offered a sum of money to a well-known investigator of the life history of fungi, Prof. de Bary, of Strasburg, to induce him to study the potato disease. Considering that De Bary had already written an admirable memoir on the *Peronospora*, there was a certain simplicity in supposing that the gift of a sum of money would elicit some additional information which his zeal as a scientific investigator had failed to do. If it does, however (and the history of the *Peronospora infestans* is not perfectly understood), it will be a clear gain; but when we are told that "Prof. de Bary has worked out the scientific questions that occur as to the origin of the disease," and that "it is owing to a fungus (*Peronospora infestans*) which attacks the leaves first, and after absorbing the nutriment of them, utilises the petiole, and thus reaches the tubes" (*sic*), it is necessary to point out that all this and a good deal more was ascertained by the Rev. M. J. Berkeley in this country, and by Montagne in France, and published by the former in a paper contributed to the first volume of the Journal of the Horticultural Society in 1846.

Nov. 20

W. T. THISELTON DYER

#### Zoological Gardens, Regent's Park

HAVING lately visited some of the Zoological Gardens on the Continent, and on my return compared those in the Regent's Park with the recollection of the former, I have been impressed that the latter appear to stand in need of much improvement.

In the first place, to adapt them to modern ideas of sanitary science, we should consider they are much too small in area for the number of inhabitants, especially as several of these are of gigantic size, and many others need naturally much space for exercise.

The *carnivora*, when bred and reared in dens of too small extent, begin to lose their muscular fulness of body, and what muscle remains becomes degenerated, and some members of their litters, reared in captivity, get affected with symptoms of paraplegia, with weakness in the buttocks and posterior limbs.

Proprietors of travelling menageries are in the habit of putting their carnivora and large animals through a series of *gymnastic performances*, which will be doubtless of as great benefit to their health as they are to the human species, and ought therefore to be introduced into our Zoological Gardens.

The *antelope* and *deer tribes*, being of nomadic disposition, should have much more space allotted to them than there is at present in the Gardens, where should be provided means for grazing and browsing in the open air, in full sunlight, and with free exposure to the winds, to ensure healthy digestion and complete aëration in the lungs.

In a city so well provided with water as London is, one must be surprised at the *scantiness of the supplies* afforded to some quadrupeds and birds, whereby what little exists very soon gets soiled and unfit for bathing and drinking purposes. These basins and ponds are seldom to be seen filled with aught else than ditch water, and are as dirty as horse ponds, whereas there might easily be designed and constructed a plan for a constant supply of fresh water to run in, and the foul water out, and thus ensure purity and cleanliness.

The casual visitor must also enter a protest against the unclean state of the cages of the *Raptorial Birds*, which are splashed all over with ordure, offensive to the sightseer in appearance and smell, and injurious to the health and plumage of the birds themselves.

The drainage of the Zoological Gardens is also so defective as to be verging on a public nuisance to the inhabitants of the banks of the Regent's Canal, so that some means must soon be taken for the better disposal of the sewage.

If facilities do not exist for extending the area of the Regent's Park Gardens, from want of power to acquire more ground, then it should become a serious question whether or not a supplementary Garden might be obtained in the suburbs further off. It could scarcely be expected that the subscribers would relinquish the retention of the present position, on account of its advantageous situation in the town for the access of visitors. It is quite possible visitors might be satisfied with much fewer animals to see, especially of those unattractive in appearance and habits, and it could easily be decreed that all these might be sent to another garden for scientific purposes alone.

Further, the second garden might be appropriated for breeding purposes, and change of air and locality for the usual inhabitants of the old enclosures and dens and cages, when the latter were required to be repaired or disinfected; and finally, it might be used as a sanatorium for the sick, and an asylum for the decrepid and disabled members of the stock, when their further exhibition in public is no longer desirable.

The great prevalence of tubercular and scrofulous diseases reported to exist amongst the animals should also be cited as indicative of a necessity for increased space and ventilation being required in the gardens, and it is much to be desired that some statistics of this class of disorders should be compiled and published for general information, giving details of its greater or less frequency in special classes of quadrupeds, birds, reptiles, and fishes.

VIATOR

It has often occurred to me that the officers in charge of our Zoological Gardens enjoy exceptional opportunities of ascertaining experimentally the limits of the intellectual and educational capabilities of the animals under their charge, but I am not aware of the existence of any systematic effort to realise the harvest of valuable and interesting information that lies here waiting to be gathered. Is not this an object worthy of the attention of the Zoological Society?

Nov. 17

C. TRAILL

#### NOTE ON THE DEVELOPMENT OF THE COLUMELLA AURIS IN THE AMPHIBIA\*

IN his paper "On the Structure and Development of the Skull of the Common Frog" (Phil. Trans. 1871), Mr. Parker states that, in the fourth stage of the tadpole,† "the hyoid arch has made its second great morphological change; it has coalesced with the mandibular pier in front and with the auditory capsule above (Plate V. Figs. 1-4, and Plate VI. Fig. 8, *s.h.m.*, *i.h.m.*) The upper part, or supra-hyomandibular (*s.h.m.*), is attached to the auditory sac much lower down and more outward than the top of the arch in front. . . . This upper distinct part is small; it answers to only the upper part of the Teleostean hyomandibular; there is a broad sub-bifid upper head answering to the two ichthyoid condyles, then a narrow neck, and then behind and below an 'opercular process' (*op.p.*) Below this the two arches are fused together; but the hyoid part is demonstrated just above the commencement of the lower third, by the lunate fossa for the 'styloid condyle' (Plate V. Figs. 2 and 4, *st.h.*)" (pp. 154, 155).

In the sixth stage:—"The supra-hyomandibular (Fig. 3, *s.h.m.*) has become a free plate of cartilage of a trifoliate form" (p. 164).

In the seventh stage:—"The 'supra-hyomandibular' losing all relation to the hyoid arch, becomes now part of

\* Read at the meeting of the British Association at Belfast, August 25, 1874, by Prof. T. H. Huxley, F.R.S.

† That is, when there is a branchial aperture only on the left side, and the hind limbs are rudimentary or very small.

the middle ear. . . . The essential element of the middle ear, the stapes (*st.*), was seen in the fourth stage; the condyles and opercular process of the hyomandibular are now being prepared to form an osseo-cartilaginous chain from the 'membrana tympani' to the stapes. Under these conditions a new nomenclature will be required; and this will be made to depend upon the *stapedial* relationship of the chain, notwithstanding its different morphological origin.

"I shall now call the lobes of this trifoliate plate of cartilage as follows—namely, the antero-superior 'supra-stapedial,' the postero-superior 'medio-stapedial,' and the freed opercular process 'extra-stapedial' (*s.st.*, *m.st.*, *e.st.*)"

"The stapes (*st.*) sends no stalk forwards to meet the new elements, but they grow towards it; this will be seen in the next stage" (pp. 169, 170).

As the question of the origin of the *columella auris* in the Vertebrata is one of considerable morphological importance, I have devoted a good deal of time, during the past summer, to the investigation of the development of this structure in the frog, and it is perhaps some evidence of the difficulty of the inquiry, that my conclusions do not accord with those enunciated by Mr. Parker, in the very excellent and laborious memoir which I have cited.

I find, in the first place, that there is no coalescence of the mandibular with the hyoidean arch, the latter merely becoming articulated with the former.

Secondly, Mr. Parker's "supra-hyomandibular" is simply an outgrowth of the mandibular arch from that elbow or angle which it makes, when the pedicle by which it is attached to the trabecula passes into the downwardly and forwardly inclined suspensorial portion of the arch. This outgrowth attaches itself to the periotic capsule, and, coalescing with it, becomes the *otic process*, or "superior crus of the suspensorium" of the adult frog.

The hyoid arch, seen in the fourth stage, elongates, and its proximal end attaches itself to the periotic capsule, in front of the fenestra ovalis and close to the pedicle of the suspensorium, which position it retains throughout life.

The *columella auris* arises as an outgrowth of a cartilaginous nodule, which appears at the anterior and superior part of the fenestra ovalis, in front of and above the stapes, but in immediate contact with it. It is to be found in frogs and toads which have just lost their tails, in which the gape does not extend further back than the posterior margin of the eye, and which have no tympanic cavity, as a short and slender rod which projects but very slightly beyond the level of the stapes, its free end being continued into fibrous tissue, which runs towards the suspensorium, beneath the portio dura, and represents the suspensorio-stapedial ligament of the *Uroelca*.

This rod elongates, and its anterior or free end is carried outwards, in proportion as the tympano-eustachian passage is developed. At the same time, the free end becomes elongated at right angles to the direction of the rod, and gives rise to the "extra-stapedial" portion, which is imbedded in the membrana tympani. Ossification takes place around the periphery of the middle of the rod; thus the medio-stapedial is produced. The inner portion becomes the rounded, or pestle-shaped, supra-stapedial, but retains its primitive place and connections, whence we find it in the adult articulated in a fossa in that part of the periotic capsule which forms the front boundary of the fenestra ovalis, but in close contact with the stapes.

The *columella auris* of the frog, therefore, is certainly not formed by the metamorphosis of any part of either the mandibular or the hyoidean arches, such as they exist in the fourth stage of larval development.

It may be said further, that the *columella* undoubtedly seems to be developed from the side walls of the auditory capsule in the same way as the stapes, and some appearances have led me to suspect that it is originally in continuity with the stapes, but I am not quite sure that such is the case. Are we to conclude, therefore, that the *colu-*

mella is a product of the periotic capsule, such as the stapes has been assumed to be?

Here, I think, there is considerable ground for hesitation. It appears to me that the stapes is not so much "cut out" of the cartilaginous periotic capsule as the result of the chondrification of a portion of that capsule which remains unchondrified longer than the rest. Moreover, the *Urodela* all possess a band of ligamentous fibres which extends from the stapes to that part of the suspensorium with which the hyoid is connected, and to the hyoid itself. It is conceivable, and certainly not improbable, that this stapedio-suspensorial ligament represents the dorsal extremity of the hyoidean arch. But the *columella auris*, in its early condition in the frog, so nearly resembles the stapedio-suspensorial ligament partially chondrified, that it is hard to suppose that one is not the homologue of the other; in which case the columella, and even the stapes itself, may, after all, represent the metamorphosed dorsal end of the hyoidean arch or the hyomandibular of a fish. And it must be admitted that the relations of the portio dura nerve to the hyomandibular in such a fish as the Ray, speak strongly in favour of this view.

## ON MIRAGE\*

### II.

WE will now modify our imaginary distribution of density in such a way as to adapt it to a convex earth. To do this we have merely to bend our diagram to the earth's curvature.

The result is shown in Fig. 3 (Plate I.), where the dotted line represents a level line coincident with a stratum of equal density in the earth's atmosphere, and, like any other level line, partaking of the general curvature of the earth. It is of the same length as the dotted line in our first diagram, and ordinates (offsets), equal to those in Fig. 1, are laid off from it, in normal directions, at the same number of equidistant points. The curves thus obtained possess all the properties, as regards foci and images, which we have pointed out as belonging to those of Figs. 1 and 2; and we can now afford to dispense with the difficult physical postulate of a diminution of density downwards from the plane of reference. One of the rays in Fig. 3 is everywhere concave downwards, and therefore the air which it traverses increases in density downwards.

If we suppose the law which gave Figs. 1 and 2 (Plate I.) to hold only on one side of the plane of reference, while on the other side of this plane the density is uniform, we shall have conjugate foci for points in the plane of reference, but for no other points. The conjugate foci will themselves be in the plane of reference, and the distance from any point to its conjugate will be constant. Rays coming to the plane of reference from the side on which the density is uniform will be bent round so as to meet the plane of reference again at a constant distance in advance of the points at which they entered, and the angle of emergence will be equal to the angle of incidence. More generally, whenever there is a layer of air in which the density diminishes very rapidly from one side to the other, while the density elsewhere is comparatively constant, rays entering this variable stratum from the denser side will (if their inclinations to the stratum are not too great) bend round in it and emerge from it again on the same side, as in Figs. 4 and 5. In Fig. 4 the dotted line may be supposed to represent a plane, beneath which the density diminishes more rapidly down to the ground (which is represented by the shading). In Fig. 5 the shading represents a stratum in which the density diminishes rapidly in ascending, the diminution being most rapid at the middle of the stratum. In both cases, the

appearance presented to an eye at E will be nearly the same as if the rays had been reflected from a plane mirror behind and parallel to the stratum; I say *nearly* the same, because the position of the equivalent plane mirror will not be precisely the same for rays at different inclinations to the stratum. Objects will thus be seen inverted, without being necessarily either magnified or diminished. Fig. 4 is intended to illustrate the mirage of the desert, and Fig. 5 to illustrate the formation of inverted images in looming. In Fig. 4, tracing the three rays backwards from the observer's eye at E, the lowest of the three at the eye end is bent up just sufficiently to prevent it striking the ground, and then goes away to the sky, so that he will see the sky as if reflected from the ground. The second ray does not pass quite so near the ground, and it goes away to a lower part of the sky. The third ray follows a similar course, not descending quite so near the ground, and going off in a direction more nearly horizontal. We may suppose it to be terminated by a tree, hill, or other tall object, which will accordingly be seen reflected beyond the image of the sky.

Rays a little higher than this will escape the upward bending which has produced these effects, and which is due to the action of a comparatively thin stratum of air near the ground. The same objects which have been seen apparently reflected by the ground will thus be also seen erect in their true positions. The relation between the appearances of the true and the reflected objects is almost precisely the same as if there were a sheet of water occupying the place of the ground; and the flickering of the air as the hotter and colder currents ascend and descend will bear a close resemblance to waves ruffling the surface of the imaginary lake.

The earliest explanation of mirage, I believe, on record is that of Monge (*Ann. de Chim.* xxix. 207), one of the *savans* who accompanied Bonaparte in his expedition to Egypt. The following is the passage in the *Annales*, which purports to be an abstract of a memoir read at a meeting of the Institute, held at Cairo:—

"At sea it often happens that a ship seen from afar appears to be floating in the sky and not to be supported by the water. An analogous effect was witnessed by all the French during the march of the army across the desert. The villages seen in the distance appeared to be built upon an island in the midst of a lake. As the observer approached them, the boundary of the apparent water retreated, and on nearing the village it disappeared, to recommence for the next village. Citizen Monge attributes this effect to the diminution of density of the inferior layer of the atmosphere. This diminution in the desert is produced by the augmentation of temperature, which is the result of the heat communicated by the sun to the sands with which this layer is in immediate contact. . . . In this state of things the rays of light which come from the lower parts of the sky, having arrived at the surface which separates the less dense layer from those which are above, do not penetrate this layer; they are reflected, and thus form in the eye of the observer an image of the sky. He thus sees what looks like a portion of the sky beneath the horizon, and it is this which he takes for water."

The only objection which I think can be taken to this explanation of Monge, is that it seems to imply not a curvature, but an angle, in the course of the rays, just as in the case of what is called *total internal reflection* at the bounding surface of a piece of glass when the angle of incidence exceeds the critical angle.

Now, the formation of an angle (even a very obtuse angle) in a ray would require a perfectly sharp transition from one degree of density to another, instead of the gradual transitions which are more in accordance with our knowledge of the properties of air. We have shown that no such harsh supposition is necessary.

As to the propriety of applying the name *reflection* to

\* A Paper read by Prof. J. D. Everett, M.A., D.C.L., before the Belfast Natural History and Philosophical Society. (Continued from p. 52.)



an action such as that represented in Figs. 4 and 5, it is perhaps just as proper as the application of the name *refraction* to the bending of rays which takes place in the atmosphere; the term refraction being primarily employed to denote bending not into a curve but into an angle, at places where a ray passes by a sharp transition from one medium into another.

The shaded region in Fig. 5 represents a portion of the atmosphere in which there is a rapid diminution of density upwards. We may regard it as the region of intermixture, between two portions of air, which differ greatly from each other in density, the denser portion extending downwards to the earth without any very rapid changes, and the rarer portion extending in a similar gradual manner upwards to the clouds. If these two dissimilar portions of air have been only recently brought into proximity, as by the commencement in the upper regions of a wind from some warm quarter, we should expect to find a border tract, where the transition would be unusually rapid, the border tract itself being indefinite in its

boundaries above and below, and the transition being most rapid in its central parts. The figure has been drawn to suit these suppositions, and it shows, besides two rays which have been reflected, a third ray which has barely been able to get through.

Anyone who is fresh from the study of optics will be at once struck with the analogy between the behaviour of these rays and of rays passing or endeavouring to pass from water into air; and the analogy is quantitative, as well as qualitative. For—

1. As regards those rays which get through, it can be shown that the total change of direction for a ray of a given incidence depends only on the densities above and below the region of intermixture, and is altogether independent of the thickness of this intermediate region. This is on the assumption that the surfaces of equal density are parallel planes. If, as in the case of air, the extreme relative index of refraction differs but little from unity, the change of direction is proportional to the tangent of the angle of incidence, and is equal to the



PLATE III.

product of this tangent by  $\mu - 1$ ,  $\mu$  denoting the relative index. This is the law which governs the refraction of rays from the heavenly bodies, in traversing the earth's atmosphere; except when these bodies are so near the horizon that the curvature of the earth and its atmosphere produces a sensible effect.

2. As a consequence of the preceding point of agreement, the critical angle which separates those rays which get through from those which are turned back, is also dependent solely on the comparison of the two extreme densities; that is, on the value of the relative index of refraction.

In the comparatively rare instances in which several inverted images of the same object have been seen in the sky, as in the third figure of Plate II., which represents a telescopic appearance observed by Scoresby, a possible explanation may be found in irregularities of form in the stratum of intermixture, which, instead of being truly horizontal, may be tilted to slightly unequal degrees in different parts, so that it acts, not like *one* plane mirror,

but like several plane mirrors slightly inclined to each other. Another, and I think more probable explanation, is the existence of more than one layer of rapid transition.

Whenever an image is inverted, the rays by which it is seen must have crossed; that is to say, the two rays which come to one and the same point of the eye from two neighbouring points of the object must have crossed each other once on the road. If they have crossed twice, the image will be erect; if three times, inverted; and so on.

When all the rays are circular arcs, and their curvatures are all equal, it will be impossible for them to cross, and hence no inverted image can be formed; neither can there in this case be any increase or diminution of apparent size. This is evident from the consideration that a diagram indicating the paths of such rays to the eye only needs to be bent with a curvature equal and opposite to that of the given rays, in order to render all these rays straight; and such bending will not affect the sizes of the images.



If, however, our rays are circular arcs of unequal curvatures, we may have crossing, and may also have magnification or diminution. It is obvious, from Figs. 6 and 7, that to give a magnified virtual image without crossing, the upper ray must be bent downwards more than the lower one; and that if the lower ray be bent down more than the upper, the image seen will be diminished.

These rules must be borne in mind in attempting to explain that very common form of mirage in which distant objects are greatly magnified in their vertical dimensions, without any other change. Fig. 4 may help us to understand how this magnification arises. If we suppose an object to travel along between two of the rays which proceed from the eye, it is clear from the diagram that the object will begin to be sensibly magnified as it enters the region of rapid change, and the magnification will increase as the object nears the intersection of these rays, at which point it becomes infinite, which practically means that, if placed at this point, it will give rise to an appearance of the greatest possible confusion. As it travels further away between the same two rays it will begin to be again recognised by a highly magnified and inverted image. One of the commonest, I believe the commonest, form of mirage in Australia is one in which small bushes at a distance are magnified into trees; and I believe the foregoing to be the correct explanation.

The magnification over water which gives rise to the architectural columns of the Straits of Messina and of the polar regions is more probably to be explained by the action represented in Fig. 6, the region of most rapid change of density being at a height somewhat greater than that of the top of the object, so that the top is greatly elevated by refraction, while the bottom remains nearly in its true place.

The quasi reflection illustrated in Fig. 4 may be produced artificially by carefully depositing alcohol or methylated spirit, to the depth of about an inch, upon water contained in a glass vessel with plane parallel sides. The spirit, though lighter, has a higher index of refraction than the water; and at the place of intermixture of the two liquids we have a gradual but very rapid diminution of index in descending. On bringing the eye close to the vessel, and looking obliquely downwards towards this part of the liquid, very perfect inverted images will be seen. The field of view afforded by this arrangement is, however, extremely limited; and a much finer effect is obtained by the arrangement now before you, in which three liquids are employed, the middle one having the highest index of refraction, while its specific gravity is intermediate between those of the other two. The three liquids are—(1) A strong solution of alum at the bottom; (2) pure water at the top; (3) Scotch whiskey mixed with enough sugar to make its specific gravity intermediate between those of the other two liquids. It is introduced last by means of a pipette.

Plate III. represents the appearance which this arrangement afforded when set up at a window of my house looking towards the mountains.

Every object in the landscape was tripled, the three images being seen at once; and the vertical breadth of the strip of landscape thus tripled at one view extended from the top of the hills down to the houses on the Lisburn road. The figure only shows the more conspicuous objects. When the sun was shining on the front of the row of houses represented, which was nearly half a mile distant, I was able to see distinctly the chimneys and windows, and even to see whether the blinds were up, down, or half-way down. It was easy to fancy that the inverted trees and houses were the reflections of the upper ones in water. But a much more striking effect, as of water, was at the place which is left white in the figure, at the junction of the middle and lower image. This had all the appearance of a calm bay or lake glistening in the sunshine. There are only two natural objects

to which this peculiar glistening belongs, with brightness far surpassing that of all the dry and solid parts of a landscape. One of these is water, and the other is the sky. A bit of sky has, in fact, been trapped between two portions of land; and it is a similar trapping of sky in the midst of dry land that produces the irresistible impression of a lake of water in the mind of the traveller in the desert. The middle image is probably formed by rays which have taken a path something like those in Figs. 1, 2, and 3. The highest and lowest image are formed by rays which have only been bent one way.

The arrangement of three liquids just described, which was suggested to me by Prof. Clerk-Maxwell, is extremely effective, but requires much delicacy in its preparation to ensure success.

Triple images of objects below the level of the vessel may be obtained by employing only the two first-mentioned liquids—alum water and pure water, or strong brine and pure water. A little gentle stirring is advantageous whichever arrangement be employed, a glass rod being inserted vertically, passed a few times slowly round the circumferential portion of the liquids, and then withdrawn.

With the two-liquid arrangement I have obtained three spectra, the middle one inverted, by employing as object a horizontal slit in the shutter of a dark room; and very brilliant colour effects were obtained by bringing the eye to the conjugate focus of the slit. A screen held at this conjugate focus, which was at first close behind the vessel of liquid, and slowly receded day by day, received an image of the slit very similar to that which would be formed by a cylindrical lens.

In order to see the three images (or spectra), it was necessary to hold the eye behind the conjugate focus. When it was held in front (that is nearer to the vessel), only two images were seen, sometimes only one, the middle or inverted image being always wanting.

A similar lengthening of focus day by day was observed with the three-liquid arrangement, which would doubtless yield similar colour effects.

#### ON THE GEOGRAPHICAL DISTRIBUTION OF THE FALLOW DEER IN PRESENT AND IN PAST TIME\*

NATURAL History shares with History the doubtful honour of having not a few chapters which are, to use a well-known expression of Tallyrand, nothing more than "des fables convenues," or which, in fact, contain generally accepted fabrications. To this shadowy side of science Geology gives the largest contributions, but Zoology, especially as regards the habits, habitats, and geographical distribution of animals, is by no means poor in them. Of the Fallow Deer (*Cervus dama*) it is generally stated in all zoological text-books, "It is a native of the Mediterranean area, and was introduced thence into Germany, Scandinavia, and England, after the Crusades." And yet the Fallow Deer was, many thousand years ago, not only an inhabitant of Africa and Western Asia, but also as much at home in Southern Russia, and even in Central Europe and Denmark, as in Italy and Southern France.

My researches into the geographical distribution of the Fallow Deer in former epochs have been caused (like those upon the history of the Domestic Fowl †) by a discovery in the ancient history of the city of Olmütz. In the same formation as the skull of the fowl there spoken of was

\* By L. H. Jeitelle. Translated from *Der Zoologische Garten* for August 1874. [I have thought it desirable that this article should be better known, as even in such recent works as Mr. Boyd Dawkins' "Cave Hunting," and the new edition of Beil's "Briti-h Quadrupeds," the ancient fable of the Fallow Deer being indigenous only in Southern Europe is repeated.—P. L. S.]

† See *Der Zoologische Garten*, bd. xiv. pp. 55 et seq.

found, along with the implements and vessels of the old Bronze period, a piece of an antler, which, from its flattened form and entire want of snags and branches, I concluded at once must be referred to the Fallow Deer. Careful comparison of it with the antlers of the Red Deer, Reindeer, Moose, and Irish Elk, in several museums, as also in rich private collections, confirmed me in this belief. Experienced students of the Cervidae agreed with me, although certainly a still more weighty authority—Herr Prof. Rüttimeyer, of Basel—indicated the possibility of the fragment from Olmütz having belonged to a Red Deer.

In the third article of his "Recherches sur les ossements fossiles," Cuvier has already mentioned the existence of fossil Fallow Deer. In page 191 (of the 8vo. edition of 1836) he speaks of "bois assez semblables à ceux du Daim, mais d'une très grande taille trouvés dans la vallée de la Somme et en Allemagne." On Plate 167 (Figs. 19a and 19b) are figured two pieces of antlers from Abbeville, of which 19b certainly belongs to *Cervus dama*. Moreover, Cuvier tells of a drawing sent to him by Autenreith (of which he gives a copy, Pl. 168, Fig. 11), "d'un crâne et d'un merrain y adhérent, déposés au cabinet de Stuttgart; pièces que ce savant rapportait au cerf à bois gigantesques, mais qui me paraissent plutôt se devoir rapporter à le Daim, à cause de la longueur de la partie cylindrique."

Subsequently similar remains of antlers were discovered at Gergovia, near Clermont, in the department of Puy-de-Dôme, and at Polignac, near Le Puy, in the department of Haute-Loire. These are spoken of by Robert under the name *Cervus dama polignacus*, by Pomel as *Cervus somonensis* and *C. Roberti*, and by Gervais (Zool. et Pal. Franc. ed. 2, Paris 1859, p. 145) under the term *Cervus somonensis*, taken from Desmarest.

Gervais says of them that they are "des bois de Daims qui indiquent une espèce ou variété bien plus grande que celle dont il a été question ci-dessus" (i.e. *Cervus dama*), and that these horns are "d'un tiers au moins plus grand que ceux du Daim ordinaire."

Georg Jäger, in his "Review of the Fossil Mammals of Wurtemberg,"\* mentions numerous discoveries of the remains of Fallow Deer in the caverns and turbaries, as also in the diluvial fresh-water chalk of Wurtemberg. Moreover, Jäger states that in the Museum of Mannheim there is not only a skull of *Bos primigenius*, but also one of *Bos prisca* and of its ally *Bos prisca affinis*, along with a skull of *Cervus dama giganteus*, from the diluvium of the neighbourhood of Mannheim.

In the Museum of Linz, in Upper Austria, are displayed numerous remains of animals from the diluvium of the neighbourhood of Wels, which were dug up at Buchberg, near Wels, when the Elizabeth Railway was made. Besides a fragment of antler of a Red Deer, a molar of *Ursus arctos* (not *U. spelæus*), a fine molar of *Elephas primigenius*, and teeth of the horse, there is in the Linz Museum, labelled as obtained from the railway-cutting, a fine large fragment of an antler which must have belonged to the Fallow Deer. Like the fragment of the Red Deer's antler from the same locality, it is whitened and has a calcined appearance. I examined this interesting specimen several times in 1870 and 1873, and have to thank Herr Kaiserl. Rath Ehrlich, the custos of the museum, for a photograph of it.

In October 1873 I examined personally the formation at Buchberg, and convinced myself of its being truly diluvium. In many places it had been dug into deeply for gravel. The horns and teeth in the museum of Linz were apparently obtained from one of these pits in the diluvium, but lay in the marly layer which is found under the gravel.

Fragments of antlers undoubtedly belonging to the

\* Nov. Act. Acad., Cæs. Leop. Car. xxiii., pars post. 1850, pp. 807, 893, 897, 899, 907.

Fallow Deer were discovered in the autumn of 1828 by Dr. Fr. Aug. Wagner in the ash-heap of an old place of sacrifice between the town of Schlieben and the village of Malitzschkendorf, in the circle of Schweinitz in Saxony, in great abundance, along with those of the elk, ox, roe, and sheep.\* Dr. Wagner, a physician in practice in Schlieben, made his researches with scientific precision, and determined the remains of the animals with care and exactness, as will be evident from his book, at the bombastic title of which one must not be alarmed. In the determination of the specimens of antlers he was assisted by the distinguished zoologist Prof. Nitzsch, of Halle. The specimen of elk's antler is figured (Tab. v. Figs. 3, 4, 5), but unfortunately none of those of the Fallow Deer. Besides remains of plants and animals, this sacrificial heap supplied bones of various sorts. As regards the Fallow Deer, Wagner writes (p. 34): "At various times in the excavation of the temple were found fragments of antlers which apparently belonged to the Fallow Deer. But as an entire specimen was never put together, nor even such fragments as could make the fact incontrovertible, it remains uncertain whether this species was sacrificed along with *Cervus alces*, and the subject requires further investigation."

Of a *Cervus fossilis dama affinis*, Alex. v. Nordmann figures five teeth in his "Palæontologie Südrusslands."† But the Fallow Deer was found even further north in the period of the diluvium and in later prehistoric times. For example, in 1871, within the city of Hamburg, and subsequently from one of the arms of the Elbe, there were disinterred numerous upper and lower jaws and fragments which differed only in size from those of the living *Cervus dama*, and the teeth of which were nearly identical. These were associated with remains of the Auerox and another large *Bos*, and with bones of the horse, pig, &c. The remains first discovered lay in compact black peat at a depth of from 20 ft. to 22 ft. among stumps of trees.‡

In the "Bulletin du Congrès international d'Archéologie préhistorique à Copenhague, en 1869," § Steenstrup has given a short description of the remains of animals from the kitchen-middens and turbaries of Denmark, which were exhibited in the University Museum on the occasion of the Congress in 1869. Amongst them (pp. 160 et seq.) he includes the Fallow Deer, of which the horns and bones are found in the upper peat-layers of Denmark.¶ At the same time he adds, "Cet animal n'est pas originaire du Danemark: il est bien constaté qu'il a été introduit dans le pays pendant le moyen âge."

Of the occurrence of remains of the Fallow Deer in England also there is some evidence given, although with a caution as to the necessity of subsequent more accurate examination, by Owen in his "History of British Fossil Animals and Birds" (London, 1846). From the peat-moor of Newbury were exhumed "portions of palmated antlers" and teeth "which accord in size with the Fallow Deer" (op. cit. p. 483.) Buckland likewise found in the large cavern of Paviland, on the coast of Glamorganshire, along with remains of the mammoth, rhinoceros, and hyæna, various antlers, "some small, others a little palmated." But Owen rightly remarks that these last may have belonged to the Reindeer just as well as to the Fallow Deer.¶

\* Detailed accounts of these discoveries are given in Dr. Wagner's "Ägypter in Deutschland oder die germanisch-sclavischen, wie rein germanischen Alterthümer an der Schwartzen Elster." Leipzig: Hartmann, 1833.

† Helsingfors, 1858-60, Pl. xviii. Figs. 4-8.

‡ Dr. F. G. Zimmerman in "Neues Jahrb. f. Mineralogie Geologie u. Palæontologie." Heidelberg, 1872, heft. 1, p. 26.

§ Copenhague, 1872.

¶ Le Daim (*Cervus dama*). Bois et ossements provenant des ébats supérieurs de la Vourte, op. cit. p. 162.

¶ Sir Victor Brooke tells me that in his opinion *Cervus brownii*, Boyd Dawkins, founded on remains from the fresh-water strata at Clacton, is identical with *C. dama*. Mr. Boyd Dawkins acknowledges that the antlers are almost alike in size and form, and apparently only distinguishes his species because *Cervus dama* "has never been found to occur in a fossil state in Northern or Central Europe."—P. L. S.

Among the remains of animals in the Swiss Pile-dwellings also have occurred fragments of horns apparently belonging to the Fallow Deer. Rütimeyer, in his "Fauna der Pfahlbauten der Schweiz," says as follows:—"A number of flat bits of shed antlers with smooth surface, in the collection of Oberst Schwab, of Biel, found in the Lake of Biel, can, to judge from their dimensions and form, be only referred to the Fallow Deer. Similar bits from Meilen, perfectly agreeing with the abnormal forms which the Fallow Deer's antlers present in aged individuals, can only be referred to this deer. Yet I must remark that no perfect antlers of this animal from the Pile-dwellings have come under my observation, nor even examples of the skull, which, next to the antlers, would give the most certain indications of this deer. Incontrovertible evidence of the spontaneous existence of this deer north of the Alps remains therefore still to be obtained."

On the other hand, there is positive proof of the existence of this deer in the "Terremare" of Italy—the equivalent of the Swiss "Pfahlbauten." In the Museum of Modena are two fragments of antlers, which Prof. Canestrini has spoken of in his "Oggetti trovati nelle terremare del Modenese," and subsequently in Mortillet's "Matériaux pour l'histoire positive et philosophique de l'homme." In 1870 Dr. Carlo Boni, former director of the Museum of Modena, had the kindness, at my request, to send these fragments to me at Basel (where I passed the winter of 1869-70), for comparison with my specimens from Olmütz, and Prof. Rütimeyer saw them too. He declared, as regards one of them (marked "624 Gorzano"), that it could not certainly be referred otherwise than to *Cervus dama*.

Besides Moravia, the Fallow Deer appears to have existed formerly in the bordering country of Lower Austria. At Pulkau, near Eggenburg, south of the Thaya, was found, in a sacrificial heap of former days examined by Dr. Woldrich, along with ancient vases, stone, bone, and horn implements, remains of the dog, ox, and Red Deer, likewise a fragment of an antler, which was "apparently a frontal snag of the Fallow Deer."

In the Middle Ages the Fallow Deer still inhabited the woods of Switzerland, as appears from the benedictions of the monk Ekkehard, of St. Gall, of the eleventh century,† and as is shown by the German edition of Gesner's "Therbuch,"‡ even at a later period. In the latter work it is said, p. 84: "Der gemeine Damhirsch wird an vilen anderen Orten gejagt, auch in den Wäldern d'Helvetien ers bey Lucern oft und vil gefangen: nennen es gemeinlich Dam, Dämlin od.' Dannhirsch, besser Damhirsch."

In a Latin edition of Gesner's "Historia Animalium,"§ now before me, however, I find no notice of the presence of *Cervus dama* in Switzerland. It is only said (i. p. 308): "Nostra vero dama etiam in Europa capitur, cum alibitum circa Oceanum Germanicum, ut audio. Germani vocant dam vel dämlin, vel dannhirsch, vel damhirsch potius; Itali daino, nonnulli danio; Galli dain vel daim; Hispani gamo vel corza."

In both editions of Gesner, moreover, Latin and German, the Fallow Deer is unmistakably figured.

According to the writing on Spekle's map of Alsace, there were Fallow Deer in Wasgau up to 1576.||

In the neighbourhood of Rome, besides, have been found numerous fragments of Fallow Deers' horns, along with remains of *Hyaena spelæa*, *Cervus tarandus*, and *Rhinoceros megarhinus*, in a Post-pliocene travertine on the heights of Monte delle Gioie.¶

\* See Woldrich in "Mitth. d. Anthrop. Gesellsch. in Wien," bd. iii. pp. 13 and 19, Pl. iv. Fig. 54 (1873).

† "Imbellens datamque laciat benedictio summam," vers. 123 of the "Bened. ad mensas Ekkehardi" in the "Mitth. d. Antiquar. Gesellsch. zu Zürich," iii. p. iii.

‡ Forer's edition: Heidelberg, 1606.

§ Editio secunda: Francforti, 1699.

¶ Gérard, "Faune historique de l'Alsace;" Colmar, 1871, p. 338.

|| Trutat et Cartailhac, "Matériaux pour l'histoire de l'homme," Vme. année 1869, p. 299.

Finally, we may remark that the Fallow Deer appears to be figured upon the Assyrian monuments; and, moreover, so faithfully as not to be mistaken for any other species of deer. We have only to look at Plates XXXV. and liii. of Layard's "Nineveh" to see this. Again, amongst the pictures upon the walls of the Egyptian tombs this species of deer is found. Its hieroglyphical name is Hanen.\*

We now come to the present geographical distribution of the Fallow Deer. Occasionally this deer still occurs wild in Western Asia. Tristram notices it as found in Mount Tabor, in Palestine, and in the woods between that mountain and the gorge of the Litany River,† and "met with it once about ten miles west of the Sea of Galilee." Lartet had previously obtained teeth of this deer from the bonebreccia of the Lebanon.‡

In Africa, according to Hartmann, the Fallow Deer is found at the present time in the shrubby desert-valleys and on the edges of the cultivated lands in Tunis, Tripoli, and Barquah, up to the Wadi Nahun.§ Gervais speaks of it as found in the neighbourhood of La Calle, in Algeria. || Loche, in his "History of the Mammals of Algeria," says that it is now rare in that province.

In the Island of Sardinia, in Cetti's time, Fallow Deer were found in enormous quantities in all parts of the island, especially in the plain of Sindia.¶ Not less than 3,000 head were at that time killed every year in Sardinia. It is remarkable that in this island the Fallow Deer is called *Crabolu*, corrupted from *Capriolo*—meaning Roe, which last animal is not found in Sardinia; whereas the Red Deer is met with occasionally, especially in the eastern portion, but attains a much less size here than on the Continent. According to Bonaparte and Cornalia ("Fauna d'Italia") this species of deer is still common in above-named island.

In Spain it seems that the Fallow Deer is seldom found wild at the present time—at least A. E. Brehm, in his "Beitrag zur Zoologischen Geographic Spaniens" in the Berliner Zeitschr. f. Allgemeine Erdkunde (1858, s. 101), can speak from personal observation only of those he met with in parks. On the other hand, Grælls mentions *Cervus dama* as an inhabitant of the Sierra Guadarrama. The Spaniards of the present day call the animal "Gamo" or "Paleto." According to Buffon (Hist. Nat. tome vi., Paris, 1756, s. 170), the Fallow Deer of Spain in his time was nearly as large as the Red Deer, and had a longer tail than the same animal in other parts of the world. Gérard (Faune Hist. de l'Alsace, s. 327) tells us that this deer is found to this day wild (*à l'état naturel*) in France, in Nivernais, the Cevennes, and in the Alps of Dauphiny. He gives no authority, and Gervais, in his "Zoologie et Paléontologie," says nothing about it.

As for Greece, Blasius says, in his "Säugethiere Deutschlands," Braunschweig, 1857, s. 455, that Bélon found the Fallow Deer in the Greek Islands. But Erhard does not mention it in his "Fauna of the Cyclades." Von der Mühle, however, speaks of it in his "Beiträgen zur Ornithologie Griechenlands," 1844, s. 1.

From the foregoing data the following conclusions may be formed:—

1. The Fallow Deer lived in prehistoric times, partially in company with other extinct mammals on the Lebanon, in Southern Russia, Italy, France, Upper Austria, Wurttemberg, Baden, Saxony, near Hamburg, and in Denmark. It appears also to have occurred in Switzerland and in England, likewise in Moravia and Lower Austria.

2. Within the historic period it was found in Egypt and Assyria, and even in the later part of the Middle Ages in Switzerland and Alsace.

\* Hartmann in Brugsch, "Zeitschr. f. Ägypt. Sprache und Alterthumsk." Jahrg. ii. p. 21.

† P. Z. S., 1866, p. 86.

‡ Bull. Soc. Géologique, France. Vol. xxii. p. 542.

§ Berliner Zeitschr. f. Erdkunde, 1868, p. 252.

¶ Zool. et Paléontol. Française. Ed. ii. p. 145.

¶ I quadrupedi di Sardegna," 1774, pp. 104, 105.

3. It is still found wild in Western Asia, Northern Africa, and Sardinia, and apparently also in parts of Spain, likewise in Greece, and perhaps also in the Cevennes and parts of Dauphiny.

4. The size and strength of the antlers, as well as the dimensions of the skull, have decreased in the course of time. Skulls of the existing Fallow Deer as well as their antlers are smaller than those of the prehistoric period.

[P.S.—Lord Lilford, whose knowledge of the larger mammals of Southern Europe is very extensive, tells me that he has himself met with Fallow Deer wild in many parts of Sardinia, in Central Spain near Aranjuez, and in the province of Acarnani in Greece.

In December 1864 the Zoological Society received from Mrs. Randal Callander a small dark-coloured Fallow Deer from the Island of Rhodes, where, however, it may have been introduced by the Knights.

Lastly, I have lately received from Mr. P. J. C. Robertson, H.B.M. Vice-consul at Bussorah, the skin and horns of a "Spotted Deer," found wild in that part of Mesopotamia, which must belong either to the Fallow Deer or to a very closely allied species.—P. L. S.]

### THE LATE SIR WILLIAM JARDINE

ORNITHOLOGISTS will learn with regret that Sir William Jardine, Bart., died, after a few days' illness, at Sandown, in the Isle of Wight, on Saturday last, the 21st of November, aged 74. The labours of the deceased baronet extend over nearly half a century. In 1825 he commenced, in conjunction with the late Mr. Selby, of Twizell, the publication of the "Illustrations of Ornithology," which seems to have been his earliest contribution to natural history, and almost immediately became recognised as one of the leading zoologists in Scotland, if not in the United Kingdom. In 1833 he undertook a still more important work, "The Naturalist's Library," forty volumes of which appeared in the course of the next ten years, and served to popularise in a most remarkable manner zoological knowledge among classes to whom it had hitherto been forbidden through the high price of illustrated works. With this publication, though its value may have been impaired by the progress of science, Sir William's name will always be identified; for, having as contributors Selby, Swainson, Hamilton Smith, Robert Schomburgk, Duncan, William Macgillivray, and others, he was yet not only the author of a large proportion of the volumes, but to each he prefixed the life of some distinguished naturalist. Of his labours, however, we cannot now speak in detail; it is sufficient to notice his excellent edition of Alexander Wilson's "American Ornithology," the establishment of the "Magazine of Zoology and Botany" (afterwards merged in the "Annals of Natural History"), and of the "Contributions to Ornithology." Sir William's expedition, with his friend Selby, in 1834, to Sutherlandshire—a country then less known to naturalists than Lapland—gave a great impulse to the study of the British fauna and flora, and almost marks an epoch in the history of biology in this island. Though ornithology was his favourite pursuit throughout life, Sir William was not merely an ornithologist—other classes of the animal kingdom had a fair share of his attention, and he was a recognised authority on all points of ichthyology. Botany and geology were also studied by him to advantage, and the science last named he enriched by his splendid "Ichthyology of Annandale," the chief materials of which were found on his own ancestral estate. With all this he was keenly addicted to field-sports, and a master equally of the rod and the gun. Sir William married first a daughter of Mr. David Lizars, of Edinburgh, and by her had a numerous family, of whom the eldest daughter was married to the late Hugh Edwin Strickland, F.R.S. After

Lady Jardine's death he married the daughter of the Rev. W. Symons, the well-known geologist. Sir William Jardine was a Fellow of the Royal Society and of the Royal Society of Edinburgh, as well as of many other learned bodies, and, until the last few years, was a constant attendant at the meetings of the British Association, in the affairs of which he had interested himself from its foundation.

### LECTURES TO WOMEN ON PHYSICAL SCIENCE

#### II.

Prof. Christschönovitsch, Ph.D. "On the C. G. S. system of Units." Remarks submitted to the Lecturer by a Student.

PRIM Doctor of Philosophy  
From academic Heidelberg!  
Your sum of vital energy  
Is not the millionth of an erg.<sup>2</sup>  
Your liveliest motion might be reckoned  
At one tenth-metre<sup>3</sup> in a second.

"The air," you said, in language fine  
Which scientific thought expresses—  
"The air (which with a megadyne<sup>4</sup>  
On each square centimetre presses)—  
The air, and, I may add, the ocean,  
Are nothing but molecules in motion."

Atoms, you told me, were discrete,  
Than you they could not be discreeter,  
Who know how many millions meet  
Within a cubic millimetre;  
They clash together as they fly,  
But *you!* you dare not tell me why.

Then, when, in tuning my guitar,  
The intervals would not come right,  
"This string," you said, "is strained too far,  
'Tis forty dynes,<sup>5</sup> at least, too tight."  
And then you told me, as I sang,  
What over-tones were in my clang.<sup>6</sup>

You gabbled on, but every phrase  
Was stiff with scientific shoddy;  
The only song you deigned to praise  
Was "Gin a body meet a body;"  
And even there, you said, collision  
Was not described with due precision.

"In the invariable plane,"  
You told me, "lay the impulsive couple;<sup>7</sup>  
You seized my hand, you gave me pain,  
By torsion of a wrist too supple.  
You told me, what that wrench would do;  
"T'would set me twisting round a screw."<sup>8</sup>

<sup>1</sup> C. G. S. system—the system of units founded on the centimetre, gramme, and second. See Report of Committee on Units: Brit. Ass. Report for 1873, p. 222.

<sup>2</sup> Erg—the energy communicated by a dyne acting through a centimetre. See Note 5.

<sup>3</sup> Tenth-metre = 1 metre  $\times 10^{-10}$ .

<sup>4</sup> Megadyne = 1 dyne  $\times 10^6$ . See Note 5.

<sup>5</sup> Dyne—the force which, acting on a gramme for a second, would generate a velocity of one centimetre per second. The weight of a gramme is about 980 dynes.

<sup>6</sup> See "Sound and Music," by Sedley Taylor, p. 89.

<sup>7</sup> See Poinso, "Théorie nouvelle de la rotation des corps."

<sup>8</sup> See Prof. Ball on the Theory of Screws: Phil. Trans., 1873.

Were every hair of every tress

Which you, no doubt, imagine mine,  
Drawn towards you with its breaking stress,  
A stress, say, of a megadyne,  
That tension I would sooner suffer  
Than meet again with such a duffer!

*d p*  
*d t*

### NOTES

WE understand that the Admiralty have appointed a committee, consisting of Admiral Sir Leopold M'Clintock, Admiral Sherard Osborn, Admiral Richards, and Capt. Evans, the Hydrographer, to advise them on all points connected with the equipment and personnel of the Arctic Expedition. The first point has been to select suitable vessels, and last week Sir Leopold M'Clintock proceeded to the northern ports to examine the whalers. It is probable that one steam whaler will be purchased, while a vessel of the *Lyra* class may perhaps be selected for the advanced ship. Both vessels will be strengthened and fitted out at Portsmouth, under the immediate superintendence of Sir Leopold M'Clintock. It is a most fortunate circumstance that the great arctic explorer, the discoverer of arctic sledge travelling, should be Admiral-Superintendent at this juncture, and that the expedition should have the advantage of being equipped, in all its details, under his vigilant supervision. The next point will be the selection of a leader, and we believe that the decision will be formed within a few days. Little doubt is entertained among naval men that the choice will fall upon Commander A. H. Markham, who acquired a knowledge of ice navigation during a cruise in Baffin's Bay and Prince Regent's Inlet last year, and who is universally considered to have all the qualifications for that important post. The number of volunteers among lieutenants, sub-lieutenants, and men is extraordinary, and is daily increasing. The committee will certainly have a wide field for selection.

It is authoritatively announced that the reward of 2,000*l.* offered some years ago by Lady Franklin for the recovery of the official records of her husband's expedition still holds, and that over and above she will be prepared to remunerate anyone who may succeed in recovering them for any outlay to which his research may subject him.

A PHYSICAL Observatory is soon to be established in Paris, and a recent vote of the Academy appointing a commission to report on the subject will not be lost. It is said that M. Janssen is to be the head of the establishment, in which solar photography will be practised on a large scale. It is also supposed that the Observatory is to be ready by the time M. Janssen returns from Yokohama with the instruments.

M. BERTRAND has been elected perpetual secretary of the Paris Academy of Science by thirty-three votes out of forty-nine. M. Faye had only thirteen votes; the other three were lost. The Chair of the Institute of which M. Bertrand is the president being thus vacated, the vice-president, M. Fremy, will preside over the sittings; M. Bertrand being moreover a member of the Section of Geometry, an election to that section will take place very shortly. He will probably be succeeded by M. Mannheim, his pupil, now a professor in the Polytechnic School and a captain in the Engineers' service. M. Mannheim is well known in England as a mathematician.

THE recent election of a perpetual secretary of the Paris Academy of Sciences is the first serious competition since Condorcet was elected to fill the place vacated by the voluntary retirement of De Faudry. It is curious that

the Condorcet election took place just a century ago, in 1774. Condorcet was supported by D'Alembert and opposed by Buffon, who supported Bailly, the astronomer. The contest of 1874 is between an astronomer, Faye, and a geometer, Bertrand. Condorcet was regarded as a geometer, as he had written a work on differential calculus. The academical regulations state that at least two-thirds of the members of the Academy must take part in a scrutiny, in order that it may be deemed valid.

THE death is announced, on the 10th inst., of Dr. Friedrich Rochleder, Professor of Chemistry in the University of Vienna.

WE are glad to notice that Mrs. Annie Mather, of Longridge House, near Berwick-on-Tweed, has handed over to the treasurer of the Newcastle College of Physical Science the munificent sum of 1,000*l.* for the founding of a scholarship or scholarships, to be called "The Charles Mather Scholarship," and to be attached to the College in perpetuity. The details of the examination and the mode of carrying out the bequest are left to be settled by the Council, subject to the approval of the donor or her advisers.

H.R.H. the Duke of Edinburgh has consented to take the chair at a meeting to be held in London on Dec. 7, in promotion of the scheme for the extension of the buildings of Edinburgh University.

THE Council of Marlborough College has recently decided to erect a laboratory and science lecture-room. The ground-floor of the building will contain the museum of the Marlborough College Natural History Society. Mr. Street will be the architect.

THE German Emperor has conferred on Dr. Samuel Birch, of the British Museum, the Order of the Crown, Second Class, in recognition of Dr. Birch's presidency of the late International Congress of Orientalists.

AN inscription has recently been set up at Galluzzo, near Florence, in memory of the late Prof. Donati, who died of cholera rather more than a year ago on his return from the Meteorological Congress at Vienna. In consequence of the strict sanitary laws in force within the city of Florence, the body was buried privately. The interment took place at night, in the small Campo Santo attached to the church of Galluzzo, not far from the new Observatory at Arcetri, in the erection of which the last three years of his life had been expended. The Commune of Galluzzo were anxious to do honour to the illustrious man, and have, at the public expense, erected a marble tablet with the inscription—

GIAMBATTISTA DONATI  
Astronomo  
nato in Pisa il xvi. di Dicembre MDCCXCVI  
scopri più Comete  
studii con lo spettroscopio perfezionato da lui  
in luce stellare  
ne chiari il fenomeno della scintillazione  
ebbe il concetto di una meteorologia cosmica  
Curò l'edificazione del nuovo Osservatorio  
su la collina di Arcetri illustrata da Galileo  
del quale continuava la bella scuola  
quando immatura morte il xvi. di Sett. MDCCCLXXXIII  
lo chiuse nell'angusta fossa  
che il Comune del Galluzzo  
onorò di questa Memoria

On the day appointed for its inauguration the rain poured in torrents, but the church of Galluzzo was crowded during the performance of a Requiem Mass, after which the congregation stood around the tomb, where speeches were made, and representatives from the Observatories of Padua and Rome presented garlands of flowers.

AT the meeting of the Geographical Society on Monday, Sir Henry Rawlinson, after expressing his gratification at the decision

of Government with regard to an Arctic Expedition, stated that he had that day heard that Col. Gordon was in Gondokoro on Sept. 5, and that he then had the sections of his steamer destined to navigate the Albert N'yanza at Mount Regia, below the falls, having full confidence of getting them transported to the smooth waters of the Upper Nile, beyond the falls, in a fortnight from that time.

WE are glad to hear that 420 teachers have this year joined the classes of the Charterhouse Teachers' School of Science.

MR. BELLAMY, F.R.C.S., commenced his course on Artistic Anatomy, at South Kensington, on Tuesday the 17th inst.

THE Royal Irish Academy has just published No. 9, vol. i., Ser. ii. of its Proceedings, which concludes the volume. This number contains eighteen papers read before the Academy during the last session, among which are several by Prof. Macalister on the myology of the gorilla, the civet, the tayra, and on the anatomy of the rare *Chæropis libermensis* and *Aonyx leptonyx*; by Mr. Mackintosh, on the myology of the genus *Bradyus*; by Messrs. Draper and Moss, on the forms of selenium; and by Mr. Hardman, on a substitution of zinc for magnesium in minerals. It is proposed for the future to publish the Scientific Proceedings of the Academy three times each year. The part to appear January 1875, to contain the Proceedings for November and December 1874; that in April 1875, the Proceedings for January, February, and March 1875; and that in July 1875, the remaining portion of the business for the session 1874-75. The Minutes of the Proceedings, to be published, each month during the session, will contain the titles of papers read, list of donations, &c.

WE have just received an important memoir on the embryology of the Ctenophore, by Prof. Alexander Agassiz. Although read before the American Academy of Arts and Sciences in November 1873, this memoir was only published at Cambridge, Mass., early in September last, giving a résumé of what was known on the subject, and calling attention to the importance of Allman's contributions to this subject, which, from the want of figures, have been too frequently overlooked. Agassiz describes the different stages in the development of *Idya roseola*, and when discussing the systematic position of the Ctenophore, which can now, from our greater knowledge of their embryology, be treated of more intelligently, he proceeds to criticise "the special interpretation of fanciful affinities and homologies existing only in forms conjured up by Ernst Hæckel's vivid imagination," and concludes that Hæckel's "assumptions, which form the basis of his Gastræa theory, are totally unsupported, and the theory must take its place by the side of other physio-philosophical systems."

THE great success of the season in the theatres of Paris is the "Tour du Monde in Eighty Days," a scientific play, written by M. Jules Verne, well known as the author of several fantastical scientific productions. Boxes are let many days in advance and sold at more than double the usual price.

THE *Journal of the Society of Arts* states that M. Mège Mouris, after analysing butter, has succeeded in making it synthetically. This imitation butter, recognised by the Conseil d'Hygiène as indistinguishable from real butter, is finding its way into the Paris markets at half the present price of real butter.

WE have received Part II. of vol. vii. of the *Transactions of the Scottish Arboricultural Society*, which contains a number of valuable papers connected with arboriculture.

M. ALIX has taken his degree of Doctor by sustaining a *thèse* on the Vol des Oiseaux (the flight of birds). The *thèse* is a large 8vo volume of 380 closely-printed pages, with many plates, and will be published by Victor Mollaux.

MR. A. W. CHASE communicates an interesting fact in connection with an account of the destruction of fish on the Oregon coast by means of the explosion of nitro-glycerine. In this he remarks that some of the fish are killed outright by the explosion, while others appear to be simply stunned; and that in several instances, after having fish apparently dead for half an hour, scaled, the intestines taken out, and prepared for cooking (the head, however, remaining on the body), they began to flop around as briskly as if just taken from the water.

THE Municipal Council of Paris has voted that a commemorative medal be given to each aeronaut who conducted a balloon out of Paris during the siege.

THE number of adult pupils who are attending the evening lectures established by the Municipal Council of Paris is 14,000, and it is expected that the number will rise to 20,000, in 1875. The number of candidates for the diploma of teacher or keeper of *Salle d'Asyle* is also rapidly enlarging. Last year it was 2,564; this year it is 3,100, both numbers including females. The number of candidates for a certificate of *études primaires* (honours of primary course of education) was 5,028.

PRIVATE letters from America announce that the proprietors of the *Great Eastern* are engaged in discussing a most extraordinary proposal. The great ship, it is said, is to be anchored in Philadelphia Harbour during the Centennial Exhibition, and to be made a great floating hotel, where 5,000 persons can be comfortably accommodated.

SIEGE balloons have been given by the Postal administration to the French War Office, which has established a Balloon Committee. The head of that institution is Col. Laussedat, of the National Engineers. The balloons are now being repaired at the Hôtel des Invalides, by Jules Godard, the youngest member of the celebrated Godard aeronautical family.

M. OPFOLZER has been appointed an Officer in the Legion of Honour for his share in the determination of the Vienna and Brezeng longitude. Two astronomers of the Paris Observatory have been promoted to the Francis-Joseph Order for the same work, one of them having been knighted, and the other, who was already a knight, having been made an Officer.

AT the special meeting of the Council of the Victoria (Philosophical) Institute, held preparatory to the commencement of the session in December, Mr. C. Brooke, F.R.S., in the chair, the election of twenty-five members took place. It was stated that papers by the following authors would be announced in a few days:—Professors Challis, Burks, Palmer, Nicholson, and J. W. Dawson; Mr. C. Brooke, F.R.S., Mr. J. Howard, F.R.S., Dr. C. B. Radcliffe, and the Rev. Dr. Irons.

PRINCIPAL TULLOCH, of St. Andrew's University (N.B.), the *British Medical Journal* states, in a recent conference with Prox Cox and Mr. Henderson of Dundee, on a proposal to erect a College for that town, to be affiliated with the University, decided that, for the present, the scheme was impracticable on account of the enormous expense which it would entail, 150,000*l.* at least. In the meantime, courses of lectures under the auspices of the University were arranged to be delivered in Dundee.

WE are pleased to see that the *Feuille des Jeunes Naturalistes*, a little scientific serial which was noticed in these columns on its first appearance in 1870, has entered on its fifth year of existence. Founded by M. Ernest Dollfus, of Mulhouse, an enthusiastic young naturalist of eighteen, it has been maintained with unflinching spirit, has met with fair commercial success, and has carried a love for natural history into many French schools, eliciting from some of the older pupils very creditable papers. The number before us contains a touching biography of M. Ernest Dollfus, who died last year. We heartily wish success to a practical and persevering enterprise.

THE new and revised edition of Griffith and Henfrey's "Micrographic Dictionary" is advancing rapidly towards completion, three numbers having been published during the last three months, bringing the work down as far as "Skin," and it is announced that the publication will now in all probability be continued without intermission till its completion. This is most desirable, considering, in the present state of science, how short a time it takes for a work of this kind to become out of date, and it is already three years since the commencement of the publication of this edition.

A MOVEMENT is on foot at the Cape of Good Hope to introduce salmon and trout into the rivers of that colony; and subscriptions are being made with the view of practically testing the idea. The only obstacle seems to be in the temperature of the water. The latitude of the Cape may be roughly taken at from 28° to 35° S., which is just within the Tropic of Capricorn, and about the same as New South Wales. These latitudes are much lower than the corresponding portions of the northern hemisphere in which trout, and specially salmon, are generally found, and we doubt whether the climate would be found suitable for them. No part of New Zealand is further north than about 35° S.; and it has not yet been proved that salmon will live in the warmer parts of that country. Still, the practical test will be in the transport of salmon to the Cape, and if the experiment succeeds, the acquisition will be well worth the risk.

THERE was a shock of earthquake at Innsprück last Thursday.

STRONG shocks of earthquake were felt on the morning of the 16th inst. at Smyrna.

WE hear that Mr. Alexander Agassiz has just started on an expedition of several months' duration to South America, with the object of exploring and investigating the natural history of Lake Titicaca, and collecting antiquities from the surrounding country for the Peabody Museum.

WE are informed that in the newly-disposed Indian Museum Dr. Forbes Watson is appointed director; Dr. Birwood, late honorary secretary to the Victoria and Albert Museum, Curator of the Museum and Assistant Reporter on the Products of India; and Mr. F. Moore, who, in conjunction with the late Dr. Horsfield, prepared the catalogue of the mammals and birds of the Museum when it belonged to the East India Company, Assistant Curator together with Dr. Cooke and Lieut. Royle.

THE *Daily Telegraph* of Tuesday contains a long and interesting letter, dated Zanzibar, Oct. 19, from Mr. H. M. Stanley, the joint commissioner of that paper and the *New York Herald* to East Africa, principally in connection with the suppression of the slave trade. The letter consists mainly of an account of Mr. Stanley's journey up one of the ten mouths of the river Rufiji as far as Kisuu, fifty miles from the sea. Mr. Stanley gives a glowing account of the river and the country through which it flows, and thinks its value, from a commercial point of view, cannot be too highly estimated. He corrects the accounts of previous travellers, and a map of the delta accompanying the letter professes for the first time to lay down correctly the various channels by which the river discharges its waters.

THE additions to the Zoological Society's Gardens during the past week include two Muntjacs (*Cervulus*?) from Formosa, presented by Mr. W. P. Galton; a Common Kestrel (*Tinnunculus alaudarius*), European, presented by Miss M. Truefitt; a Roseate Cockatoo (*Cacatua roseicapilla*) from Australia, presented by Mr. H. I. Aveling; a Pomerine Skua (*Lestris pomarinus*), European, new to the collection, purchased; a Black-eared Marmoset (*Hapale penicillata*) from South-east Brazil, deposited.

## SCIENTIFIC SERIALS

THE *Transactions of the Linnean Society*, vol. xxx., part 2, is almost entirely occupied by Mr. Miers' paper On the Lecythidaceae. The author prefers Lindley's proposal of erecting this group into a distinct order rather than making it a sub-tribe of Barringtoniaceae, itself a tribe of Myrtaceae, as Bentham and Hooker have done in their "Genera Plantarum." The order will then be characterised by its alternate impunctate leaves, epigynous stamens, petaloid appendage to disc on which the stamens are seated, and peculiar fruits and seeds very different from those of Myrtaceae, and will consist of the following twelve genera—*Gustavia*, Linn. (2 sp.); *Coussoupta*, Aubl. (9 sp.); *Bertholletia*, H. and Bonpl. (2 sp.); *Lecythis*, Linn. (42 sp.); *Chytroma*, nov. gen. (*Lecythis* in parte auct., 25 sp.); *Eschweilera*, Mart. (46 sp.); *Jugastrum*, nov. gen. (*Lecythis* in parte auct., 6 sp.); *Couartari*, Aubl. (8 sp.); *Cariniana*, Casar. (7 sp.); *Allantoma*, nov. gen. (12 sp.); *Grias*, Linn. (4 sp.); and *Cercophora*, nov. gen. (1 sp.) Many of the species are now described for the first time, and the paper is illustrated by thirty-three beautiful plates, illustrative of each of the genera, and of the fruits and seeds of a large number of the species. The part contains also the Rev. O. P. Cambridge's "Systematic List of the Spiders at present known to inhabit Great Britain and Ireland: " 78 genera and 457 species.

THE *Journal of Botany* for the four months, August to November, 1874, contains the following among the more important original papers:—In descriptive phanerogamic botany, Mr. W. P. Hiern contributes Notes on Ebenaceae, with description of a new species; Dr. H. F. Hance, a description of some Asiatic Corylaceae; a paper On a small collection of plants from Kinkiang, and another On three new Chinese *Calami*; Mr. J. G. Baker, a paper On the genus *Androcymbium* (Colchicaceae), with description of seven new species; a description of a new species of *Helmopsis* (Colchicaceae) from Formosa; and an article On the *Allurus* of India, China, and Japan; and Dr. J. Müller describes a number of new Euphorbiaceae collected by Dr. Lorenz in the Argentine Republic.—In cryptogamic botany, Mr. E. M. Holmes describes and draws a very rare British moss, *Dicranum flagellare*; the Rev. J. M. Crombie also describes and draws a new genus of lichens, *Phycographa*, Nyl., and gives a valuable revision of the British Colemaceae.—In geographical and local botany, Miss E. Hodgson gives a sketch of the botany of North or Lake Lancashire; Mr. J. F. Duthie a very interesting paper On the botany of the Maltese Islands in 1874; Mr. T. R. Archer Briggs, Notes on some plants of the neighbourhood of Plymouth; and the editor completes his Botanical Bibliography of the British Counties.—In each number there are also, in addition, a number of short notes and queries, extracts and abstracts of important papers published elsewhere, and reviews of books. The editor continues the extremely useful practice of giving a list of the botanical papers in each month's home and foreign journals.

*Astronomische Nachrichten*, Nos. 2,010 and 2,011, contain a paper by H. J. H. Groneman, on his theory of the aurora. He goes into the questions of the annual variation and the eleven-year period, together with its height and magnetic effects.—In No. 2,012 there is a letter from Stephen Alexander on the observation of the varying brightness of Jupiter's satellites as seen in transit, and he discusses M. Flammarion's explanation of this phenomenon.—J. G. Galle contributes a paper on the observations of the planet Flora, made by Dr. Gould and contained in this number, and discusses them with reference to their giving a value of the solar parallax.—In No. 2013, Dr. Holetschek gives an hypothetical ephemeris for the planet Peitho (118) from Oct. 7 to Nov. 12, for the purpose of recognising the same.—A. Grützschacher gives position observations of Borrelly's comet, made during August.—Dr. Holetschek has estimated the orbit of Comet I., 1871, and contributes details of the orbit. Its period seems to be 5188 years.—C. T. W. Peters gives time observations on the solar eclipse of Oct. 9, 1874.—J. H. Safford sends his computation of the orbit of Alcmene, and an ephemeris for March and April 1875.

*Zeitschrift der Oesterreichischen Gesellschaft für Meteorologie*, Nov. 1.—In this number we have the first part of an article by Dr. J. Hann, on the laws of change in temperature of ascending currents of air, and some of the consequences thereof. He observes that although Poisson's equation, by means of which we may reckon the loss of temperature of ascending air by expan-



sion, has long been known, it has not been made full use of in discussing atmospheric phenomena, such, for example, as the rainfall on mountain slopes. The works of Sir W. Thomson, Reye, and Peslin bring us important information regarding the movements of ascending air, for they deduce from the mechanical theory of heat the laws of variation of temperature in ascending and descending dry and moist currents. Calculating in the first instance the fall of temperature in ascending currents where no condensation of moisture takes place, the following result is obtained:—For every 100 metres rise, nearly exactly  $1^{\circ}$  C. is lost, whatever the original level and temperature may have been; and conversely for descending currents. If any vapour be present, as long as it is not condensed, it reduces this rate only to a very slight extent. As to the relation between pressure and temperature, a fall of 20 mm. would be accompanied by a decrease of  $2.1^{\circ}$  C., but since such a fall takes something like twenty-four hours at least, changes of this kind are probably overborne and hidden by simultaneous changes depending on other causes. Secondly, he calculates the loss of temperature in ascending currents becoming saturated and continually losing by condensation part of their moisture. This quantity differs greatly with the amount of vapour originally in the air, and therefore with the temperature at which the air becomes saturated. By means of a formula arrived at by Dr. Hann, a table has been constructed, showing the calculated loss of heat at various pressures, heights, and temperatures. An ascending column of air obeys the law for dry air until it reaches the dew-point; after this the table should be consulted. Supposing a current at  $10^{\circ}$  C. to impinge on a mountain slope and rise to the summit, 2,600 metres high, if moist, it loses  $14.8^{\circ}$  C.; if dry,  $26^{\circ}$ . But in descending the lee side it gains, whether moist or dry,  $26^{\circ}$ . If it was saturated at the mountain top, it will be relatively very dry after its descent; and if originally moist, about  $10^{\circ}$  warmer than it was on the windward side.

## SOCIETIES AND ACADEMIES

### LONDON

Linnean Society, Nov. 19.—Dr. G. J. Allman, F.R.S., president, in the chair.—Mr. Daniel Hanbury exhibited specimens of the rose cultivated on the southern slopes of the Balkan for the production of attar of roses, which Mr. J. G. Baker stated to be probably a variety of *R. damascena*.—The President then read a paper on *Stephanoscyphus mirabilis*, the type of a new order of Hydrozoa. The author described a remarkable organism which occurs imbedded in sponges on the southern shores of France. It forms composite colonies which have a general resemblance to a campanularian hydroid, with its cup-like hydrothecae or so-called polyp cells, opening on the surface of the sponge, and, when the animal extends itself, giving exit to a beautiful crown of tentacles. It has, however, though a true hydrozoan, no immediate relation with the campanularians or with any other hitherto recognised order of Hydrozoa; for the hydrothecae-like receptacles are occupied not by a hydranth or polypite, but by a body which has all the essential characters of a Medusa; and the tentacles which are displayed when the animal extends itself are really the marginal tentacles of a Medusa. It is, further, provided with the radiating and circular canals of a true Medusa. The animal is essentially a composite colony of medusiform zooids included in a system of chitinous tubes, from which, like a campanularian hydroid, each zooid has the power of extending itself, and within which it can again retreat. The author regarded the *Stephanoscyphus mirabilis* as the type of a new order of Hydrozoa, to which he assigned the name of "Thecomeduse." He regarded *Stephanoscyphus* as affording a convincing proof of the homology on which he had formerly insisted in parallelising the tentacles of a hydranth with the radiating canals of a Medusa. An interesting discussion followed, in which Prof. Busk, Dr. Murie, and others bore testimony to the great importance of Prof. Allman's discovery.—Dr. Masters read a "Monograph of Durionaceæ." The paper contains an enumeration of the genera and species of the tribe Durionaceæ, together with descriptions of the new species found by Beccari in Borneo, &c. It is accompanied by some remarks on the morphology and geographical distribution of the group. In both respects the group is very distinct. The peculiar scaly pubescence, the compound stamens, the (in some cases) very peculiar anthers, and the mucrate fruits, all constitute remarkable features. The question of "divided" or "compound"

stamens, which has of late been re-discussed by Chatin, is alluded to, with the result that the author adheres to his previously expressed views on the subject—views, moreover, supported by those of Payer, Sachs, Baillon, Van Tieghem, and others. The nature of the petals in Malvales in general is also touched on; sometimes these appear to be autonomous organs, while in other cases they seem to form part and parcel of the staminal phalanges. (For fruit of the Durionaceæ as an esculent, see Wallace, and "Treasury of Botany," art. "Durio.")

Chemical Society, Nov. 19.—Prof. Odling, F.R.S., president, in the chair.—Dr. C. R. A. Wright read a paper on the action of organic acids and their anhydrides on the natural alkalis, Part II., by himself and Mr. Beckett; being a continuation of that which he brought before the Society at the last meeting.—Prof. W. K. Clifford then made a communication On general equations of chemical reactions, proving mathematically, from the kinetic theory of gases, the generally adopted method for expressing chemical reactions. An interesting discussion ensued, after which the following papers were read:—On propionic coumarin, and some of its derivatives, by W. H. Perkin, F.R.S.; On the composition of autunite, by Prof. A. H. Church; and the action of bromine on protoacetic acid, gallic acid, and tannin, by J. Stenhouse, F.R.S.

Zoological Society, Nov. 17.—Mr. George Busk, F.R.S., in the chair.—The Secretary exhibited on behalf of the Rev. J. S. Whitmee an egg of *Pareudastis pacificus*, and an accompanying egg of the Samoan Porphyrio.—A communication was read from Sir Victor Brooke, Bart., containing some remarks on the identity of a certain deer in the Society's collection, which had been determined as *Cervus savannarum*.—A series of eggs of Megapodes (*Alcedipodis*) transmitted by Mr. John Brazier, was exhibited. These had been obtained from different islands of the Solomon group.—Mr. R. B. Sharpe also exhibited some Megapodes' eggs from the southern part of New Guinea.—Prof. Mivart read a paper on the axial skeleton of the Struthionidae, and pointed out that judging, by the characters of the axial skeleton, the Emeu presents the least differential type; from which Rhea diverges most on the one hand and Apteryx on the other; that the resemblance between Dromæus and Casuarii is exceedingly close, while the axial skeleton of Dinornis is intermediate between that of Casuarii and Apteryx; its affinities, however, with the existing New Zealand form very decidedly predominating.—A communication was read from Major H. H. Godwin-Austen, describing five new species of Helicidae, of the sub-genus Plectopylis, from the Khasi and Naga Hills, from Darjeeling and from the Burmese region.—Mr. R. Bowdler Sharpe read a paper on the larks of Southern Africa, in which an attempt was made to reduce into order the numerous genera and species of this difficult group.—A communication was read from Dr. J. Anderson, pointing out that his *Macacus brunneus* was truly distinct from *M. arctoides* of Geoffr. St. Hilaire.—A communication was read from the Count Turati and Dr. T. Salvadori, describing a new Trogon of the genus Pharomacrus, proposed to be called *P. xanthogaster*.—Dr. Albert Günther read a description of a new species of kangaroo from North-west Australia, proposed to be called *Halmaturus apicalis*.—Mr. P. L. Slater read a notice of some specimens of the Black Wolf of Thibet, now or lately living in the Society's menagerie.—Mr. H. E. Dresser exhibited eggs of the various European species of Hypolais, together with those of *Acrocephalus streperus* and *A. palustris*, and pointed out that these two groups (Hypolais and Acrocephalus) approach each other in their eggs as well as in other characters, the two nearest allied in each group being *Hypolais rama* and *Acrocephalus palustris*.—Mr. W. T. Blanford read a notice of two new Uromastixine lizards from Mesopotamia and Southern Persia, proposed to be called *Uromastix microlepis* and *Centrotrachelus loricatus*.—A new species of ichneumon, and of a hare collected by Mr. F. Day in Sind, and new to the Indian fauna. One of the former and the hare were believed to be new to science, and were called *Herpestes ferrugineus* and *Lepus dayanus*.

Meteorological Society, Nov. 18.—Dr. R. J. Mann, president, in the chair.—The President read a "Report concerning the meeting of the Conference on Maritime Meteorology in London, August 31, 1874," which he had attended as the representative of the society.—At the request of the president, Mr. R. H. Scott gave a brief account of the recent meeting of the Permanent Committee of the Vienna Congress at Utrecht.—The following papers were then read:—On the weather of thirteen



springs, by R. Strachan, F.M.S.—Table for facilitating the determination of the dew-point from observations of the dry and wet bulb thermometers, by William Marriott, assistant secretary. The chief feature of this table is, that it gives, for the difference between the readings of the dry and wet bulb thermometers, the amount to be subtracted from the reading of the wet thermometer instead of from that of the dry, as is necessary with the other tables now in use; thus effecting a saving of time of more than one-third of that required by the ordinary method.—On the heat and damp which accompany cyclones, by the Hon. Ralph Abercromby, F.M.S.

Royal Horticultural Society, Nov. 11.—Scientific Committee.—A. Murray, F.L.S., in the chair.—Specimens of the Coffee Fungus (*Hemileia vastatrix*) were shown, and an extract from a letter of Dr. Thwaites on the same subject was read, in which it was stated that the periodicity of the worst phase of the disease had now been demonstrated. Flowers of sulphur, Dr. Thwaites thought, would be a useful but impracticable remedy. The filaments produced by the spores of *Hemileia* penetrate the stomata of the leaf from the outside. It was difficult before to understand what should determine the outbreak of the disease in certain parts of the leaves, the intermediate parts seeming to be quite free from it.—The Rev. M. J. Berkeley showed roots of apple affected with American blight, *Eriosoma lanigerum*.—Pears were sent by Mr. H. Webb, the cracking of which Mr. Berkeley attributed to *Spilocaca pomi*, Fr., which he regarded as a state of *Helminthosporium pyriforme*.—Dr. Gilbert contributed, on the part of J. B. Lawes, F.R.S., a note on the occurrence of fungi on the various plots devoted to experiments with different manures on permanent meadow-land at Rothamstead, Herts. The general conclusion appeared to be that fungi flourished the best where the development of the grasses was the least, and where the limited growth of these was due to a deficient supply for their requirements of nitrogen or of potash, or of both. The dry substance of fungi appears to consist of from  $\frac{1}{4}$  to  $\frac{3}{8}$  of albuminoids, yet, as in the case of the highly nitrogenous leguminous crops, direct nitrogenous manures, such as ammonia salts or sodium nitrate, do not seem to be specially favourable to their growth. The dry substance of fungi contains 8 to 10 per cent. of ash, of which 80 per cent. is potassium phosphate. Yet the greatest development of fungi was on plots on which, measured by the requirements of grasses, potash was relatively deficient.—Dr. Voelcker stated that fairy rings occur on poor pastures, and the best mode of extirpating them consists in the application of nitrogenous manures.—Mr. Renny thought that rank-growing grass was not nearly so favourable for the growth of fungi as old pasture or common.

Entomological Society, Nov. 2.—Sir Sidney Smith Saunders, president, in the chair.—Mr. Stevens exhibited three specimens of *Diopisa pulchella* taken at Arundel and Deal. Prof. Westwood remarked that the late Lieutenant-General Hearsay had found this insect very destructive to gardens in India.—Mr. Bond exhibited specimens of rare Lepidoptera; amongst them were *Sesia culiciformis* (with yellow bands), *Limacodes asclus*, *Nola albulalis*, and *Pterophorus rhododactylus*.—Mr. Jenner Exhibited specimens of *Mantis religiosa*, with some egg-cases taken by himself at Meran, in Tyrol.—Mr. McLachlan exhibited a printer's block (such as is used for printing posters), attacked by a species of Anobium, and he was informed that the insect was causing serious damage to the printer's stock. The wood was believed to be pear-tree. He had recommended soaking them in carbolic acid and water.—Dr. Sharp communicated "Descriptions of some new genera and species of Pselaphidae and Scydmaenidae from Australia and New Zealand." He added some remarks respecting the importance of gaining a knowledge of the New Zealand fauna, and commented on the probable extinction of many of the species at a not very distant period.—Mr. Darwin communicated some remarks by Mrs. Barber, of Griqualand, South Africa, on the larva of *Papilio nireus*, and especially with regard to the colour of the pupa in connection with the objects on which it was placed, it appearing to assume a protective resemblance to the leaves or other adjacent objects. A discussion took place between several of the members as to whether, as suggested by Mrs. Barber, some photographic influences might be at work; but Mr. Meldola stated that no known substance retained, permanently, the colour reflected on it by adjacent objects; but that there was no difficulty in believing that larvae might become affected in colour by the colouring matter of the food-plant, since chlorophyll in an unaltered condition had been found in the tissues

of green larvae.—Mr. Ogier Ward sent some notes on a spider's nest found in a quarry at Poissy, near the Seine, with some remarks thereon by Mr. C. O. Waterhouse.—Mr. Butler communicated, "Descriptions of three new species and a new genus of Diurnal Lepidoptera from West Africa, in the collection of Mr. Andrew Swazzy."—Mr. C. O. Waterhouse read "Notes on Australian Coleoptera, with descriptions of new species."—Mr. Kirby contributed a review of Boisduval's "Monographie des Agaristides, published in the *Revue et Magasin de Zoologie*, 1874."—The Rev. R. P. Murray communicated "Descriptions of some new species of Butterflies belonging to the genus *Lycæna*."

Nov. 16.—J. W. Dunning, M.A., F.L.S., the vice-president, in the chair.—Mr. Higgins exhibited some rare specimens of Cetonidae from Borneo, viz., *Lomaptera Higginsii*, O. Janson, and a remarkable Dynastiform insect, named by Count Castelnau *Westwoodia Howittii*; also two smaller specimens, which had been supposed to be females of the last-named species, but were more probably those of an unknown species.—The Secretary exhibited a collection of fine species of Lepidoptera sent by Mr. W. D. Gooch from Natal for determination.—The Rev. O. Pickard-Cambridge sent a note on the curious spider's nest exhibited at the last meeting. It was unknown to him, and had it not been for a remark in Mr. Ward's letter implying that the nest he found belonged to a geometrical web, he should have conjectured that it was the work of an *Agelena*. If, however, the nest was appurtenant to a geometrical web, it must belong to a spider of the family Epeiridae. He did not think the sand in the nest was at all designed as ballast, but as a protection from the rays of the sun and also from parasites. Mr. Smith remarked that the mud coating of the nest of *Agelena brunnea* did not preserve that species from parasites, as he had often bred a species of *Pezomachus* from the nests, and he believed, in those cases, the eggs were attacked before the mud coating was added.—Mr. Champion exhibited some rare species of British Coleoptera, viz., *Apion Ryei*, *Ardera triguttata*, *Lymexylon navale*, *Athous subfuscus*, *Silvanus similis*, and *Apion sanguineum*.

Institution of Civil Engineers, Nov. 10.—Mr. Thos. E. Harrison, president, in the chair.—On the Nágpur Water-works; with observations on the rainfall, the flow from the ground, and evaporation at Nágpur; and on the fluctuation of rainfall in India and in other places," by Mr. Alex. R. Binnie, M. Inst., C.E. From a study of the records of rainfall at Calcutta, Bombay, Madras, Nágpur, Mauritius, Barbadoes, Adelaide, Hobart Town, Cape Town, New York, Rome, Greenwich, New Bedford, U.S., and Prague, the author deduced that the fluctuations were similar in kind, and that they only differed slightly in amount.

## MANCHESTER

Literary and Philosophical Society, Nov. 3.—Rev. Wm. Gaskell, vice-president, in the chair.—On the corrosion of leaden hot-water cisterns, by Prof. H. E. Roscoe, F.R.S.—On an improvement of the Bunsen burner for spectrum analysis, by Mr. F. Kingdon, assistant in the Physical Laboratory, Owens College. The students in the Physical Laboratory of Owens College having occasionally experienced some difficulty in obtaining the spectra of some salts with the ordinary Bunsen, through apparently a deficiency of pressure in the gas, it occurred to me that the amount of light even at this deficient temperature might be increased by multiplying the number of luminous points. This is accomplished by broadening out the flame of the Bunsen, that is, causing the gas to issue through a narrow slit instead of a round hole. We have, so far, only made a rough experiment, the slit being about  $\frac{7}{8}$  in. long and  $\frac{1}{8}$  in. wide. The result is, as expected, a more brilliant spectrum.—Some notes on Pasigraphy, by Mr. Henry H. Howarth, F.S.A.—On the existence of a lunar atmosphere, by Mr. David Winstanley.

## GLASGOW

Geological Society, Nov. 12.—Mr. A. E. Wünsch, vice-president, in the chair.—The Chairman gave a preliminary notice of an interesting discovery which had recently been made in Arran, during a joint exploration of the northern part of the island, in company with Mr. James Thomson, F.G.S. In the course of their examination of those large masses of red sandstone adjoining the carboniferous series of Arran, whose age and geological position have hitherto been doubtful, they came upon a bed of conglomerate of highly glacial

aspect, enclosing angular fragments of various schistose, volcanic, and limestone rocks; and in the latter Mr. Thomson detected the familiar aspect of carboniferous shells and corals. Having once obtained this clue, it was not difficult to find other beds at higher and lower levels, containing similar traces of carboniferous fossils, thus fixing these massive beds of sandstone as undoubtedly of Lower Permian age.—Mr. J. Young, F.G.S., read a joint paper by himself and Mr. David Robertson, F.G.S., on the Polyoza and other minute organisms found in the carboniferous limestone shale at Hairmyres, East Kilbride.—Mr. D. Bell described some remarkable glacial mounds seen in the neighbourhood of Balquhider, on the line of railway between Callander and Killin. At Kingslubaig and Callander. Mr. Bell next called attention to another series of mounds presenting similar features, which occur in the "side-glen" called "Glen Buckie," or the Calair Burn, that opens out southward from Balquhider and leads on to Glenfinlas in the Trossachs. He then referred to some points connected with the silting up of lakes, as presented by Loch Lubnaig and Loch Voil, which were once in all probability united.

BOSTON, U.S.

Natural History Society, March 4.—The president in the chair.—Mr. Bouvé introduced the subject of Dr. Genth's theory of the metamorphism of corundum, which has lately been published, and explained the meaning of the terms "metamorphism" and "pseudomorphism" as used in mineralogy.—Dr. T. Sterry Hunt then spoke on Dr. Genth's researches on corundum and its associated minerals. The speaker, while praising the industry and chemical skill displayed in the paper of Dr. Genth, insisted upon the importance of some clear definitions: as to replacement, alteration, and association in the mineral kingdom, for the lack of which he conceived the learned author, in common with many others, had fallen into errors, and had been led to conclusions wholly untenable. He then explained the nature of pseudomorphs. He had not only carefully studied Dr. Genth's paper, but through the courtesy of that gentleman had examined with him the extensive collection of specimens upon which the conclusions announced by Dr. Genth had been based, and while bearing testimony to his accuracy and skill as a chemist and mineralogist, maintained that all of the phenomena in question were nothing more than examples of association and envelopment. All the facts regarding the corundum-bearing veins described by Dr. Genth have their parallels in the granitic veins with beryl and tourmaline, so common in Montanah, or White Mountain rocks of North America, and in the calcareous veinstones, with apatite, pyroxene, phlogopite, and graphite, of the Laurentian rocks, both of which classes of veins have elsewhere been described by the author.

PARIS

Academy of Sciences, Nov. 9.—M. Bertrand in the chair.—A telegraphic despatch from M. Janssen, announcing the safe arrival of the Transit of Venus Expedition at Nagasaki, was read.—M. Alph. de Candolle presented a copy of his Report for 1873-74, published as president of the Physical and Natural History Society of Geneva.—The following papers were read:—Researches on the dissociation of crystalline salts, by MM. P. A. Favre and C. A. Valson.—Method employed in seeking the substance the most efficacious against Phylloxera at the viticultural station of Cognac, by M. Max Cornu.—Memoir on the secular inequalities of the major axes of the planetary orbits, by M. Emile Mathieu.—On some geometrical constructions applicable to mirrors and lenses, by M. J. Lissajous.—Preparation and properties of dioxymaleic acid, by M. E. Bourguin. This acid is prepared by heating Kekule's bibromomaleic acid with silver oxides and water—

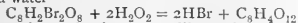

The new acid is colourless crystalline, soluble in water and alcohol, hardly soluble in ether. It presents the triple character of a dibasic acid, a diatomic alcohol, and an unsaturated acid. Its isomer, "tricarboic acid," obtained from cyanoform, is a tribasic acid.—Trial of comparison between the principal systems of aerial navigation, by M. Duroy de Brignac.—On the volcanoes of the Isle of Java and their relation with the pentagonal ridge, by M. Alexis Perrey.—Studies relating to Phylloxera. Experiments made on branches of vines immersed in water holding various substances in solution, by M. A. Baudrimont.—A letter from M<sup>me</sup>. Janssen was read, giving details of the effects of the recent typhoon at Hong Kong.—On a formula for transforming elliptic functions, by M. Brianchon.

—On the laws of the vibratory motion of tuning-forks; second note by M. E. Mercadier.—On electrostatic induction currents, by M. Neyreneuf.—Action of the electric current on the organs of sensation, by Dr. T. L. Phipson.—Reply to recent note by M. Gernoz on supersaturation, by M. Lecoq de Boisbaudran.—New observations relating to the circular compass, by M. E. Duchemin.—Bisulphide of carbon and nitric oxide lamp; application to photography, by MM. B. Delachanal and A. Mermet. The photographic intensity of this lamp is stated to be superior to that of magnesium, to be twice as great as that of the oxyhydrogen light, and three times as great as the electric light. Unlike the electric and magnesium lights, the flame is steady and not liable to sudden extinction.—On the chemical nature of the substances which in the organism give the cross by polarisation, by MM. Dastre and Morat.—Note relating to the inundations of the valley of the Po in 1872, by M. Dausse.—At the beginning of the meeting M. Leverrier presented to the Academy chaps. xix. and xx. of his "Recherches Astronomiques," and a complete theory of the motions of Uranus.

Geographical Society, Nov. 4.—M. Delesse, president.—The Secretary announced that the Abbé Petitot, a missionary who has explored the Mackenzie River, has prepared a map of that little known region.—A letter was read from M. de Lesseps, who states that he has by no means given up the project of a Trans-Asiatic railway. His son has been exploring the Himalayas, and reports on the different routes by which the iron road could be carried.—M. Foucher de Careil presented the Society with a copy of his work entitled "Leibnitz and Peter the Great." The author points out three geographical discoveries which he declares are due to Leibnitz. He shows that it was by his advice that Peter the Great sent out the expedition under Behring, the discoverer of the strait which bears his name. The author also mentions three memoirs by Leibnitz on the determination of longitude according to the variation of the compass, a discovery with which Gauss was credited nearly a century later.—M. Simonin gave details of a journey which he made through the north of the United States, and especially in the region of the Great Lakes.

#### BOOKS AND PAMPHLETS RECEIVED

BRITISH.—A Course of Qualitative Chemical Analysis: Wm. G. Valentin. new edition (J. and A. Churchill).—Histology and Histo-Chemistry of Man: Heinrich Frey. Translated by Arthur E. F. Barker (J. and A. Churchill).—Post-Tertiary Entomo-traces of Scotland: G. S. Br. dy, C.M.Z.S., Rev. H. W. Crosskey, F.G.S., and David Robertson, F.G.S. (Palaeontological Society).—Bacon's Thoughts, Philosophical and Medical: John Dowson, M.D. (H. K. Lewis).—Erasmus Darwin: John Dowson, M.D. (H. K. Lewis).—Journal of the Society of Telegraph Engineers: Major Frank Bolton and Geo. E. Preece (Spott).—Dental Pathology and Surgery: S. J. A. Salter, M.B., F.R.S. (Longmans).—Doctrine of Energy: D. D. Heath, M.A. (Longmans).—Manchester Historical Recorder (John Heywood, Manchester).

AMERICAN.—Report of the Commissioner of Agriculture, 1872 (Washington, U.S.).—Bulletin of the Buffalo Society of Natural Sciences (Warren, Johnson, and Co., Buffalo, U.S.).—Catalogue of Plants (Army Department, Washington, U.S.).—Report of Ornithological Specimens (Washington, U.S.).

FOREIGN.—Cours de Géologie Comparée: Stanislaus Meunier (Firmin Didot and Co.).—Experimentalphysik: Dr. Adolf F. Weinhold (Leipzig).—Degli Studi Fisici di Ambrogio Fusinieri (Foligno).—Über die Abhängigkeit des Klimatischen Characters der Winde: Dr. W. Köppen (St. Petersburg).

#### CONTENTS

	PAGE
THE ENGLISH ARCTIC EXPEDITION . . . . .	61
OBSTACLES TO SCIENTIFIC RESEARCH . . . . .	62
THE SECOND GERMAN ARCTIC EXPEDITION (With Illustrations) . . . . .	65
DRAYSON'S "PROPER MOTION OF THE FIXED STARS," ETC. . . . .	66
OUR BOOK SHELF . . . . .	67
LETTERS TO THE EDITOR:—	
ROYAL AGRICULTURAL SOCIETY and the Potato Disease.—Prof. W. T. THISELTON DYER, F.L.S. . . . .	67
Zoological Gardens, Regent's Park.—VIATOR; C. TRAILL . . . . .	67
NOTE ON THE DEVELOPMENT OF THE COLUMBELLA AURIS IN THE AMPHIBIA. By Prof. T. H. BARKLEY, F.R.S. . . . .	68
ON MIKAGE, II. By Prof. J. D. EVERETT, D.C.L. (With Illustration) . . . . .	69
ON THE GEOGRAPHICAL DISTRIBUTION OF THE FALLOW DEER IN PRESENT AND IN PAST TIME. By L. H. JEITTELES. . . . .	71
THE LATE SIR WILLIAM JARVIS, F.R.S. . . . .	74
LECTURES TO WOMEN ON PHYSICAL SCIENCE, II. . . . .	74
NOTES . . . . .	75
SCIENTIFIC SERIALS . . . . .	77
SOCIETIES AND ACADEMIES . . . . .	78
BOOKS AND PAMPHLETS RECEIVED . . . . .	78

THURSDAY, DECEMBER 3, 1874

## SAXBY'S "BIRDS OF SHETLAND"

*The Birds of Shetland, with Observations on their Habits, Migration, and Occasional Appearance.* By the late Henry L. Saxby, M.D., of Balta Sound, Unst. Edited by his brother, Stephen H. Saxby, M.A. 8vo., pp. 398; eight plates. (Edinburgh: 1874.)

JUST as no country can show such a number of works on Ornithology as our own,\* so no branch of our fauna has received anything like the same degree of attention, which the existence of such works implies, as birds. These works are of various grades of excellence, as might naturally be expected, but there are few that do not contain more or less valuable matter, and none that can be safely neglected by ornithologists; while some, as Mr. Stevenson's "Birds of Norfolk," Mr. Gray's "Birds of the West of Scotland," and of course Thompson's "Birds of Ireland," rise to a very high order of merit. The book now before us—the late Dr. Saxby's "Birds of Shetland,"—does not, indeed, nearly reach the standard of those just named as a whole; but in some respects it does not fall far below it, because the locality of itself gives an importance to the subject which no imperfections can impair—and the work certainly labours under several manifest and serious defects. It will be enough to mention three of them. First, there is the deplorable fact of the author's premature death, and the posthumous publication of his book consequent thereupon; for though his brother has doubtless done all in his power to discharge the duty of editor—and, let us say at once, has done this very creditably—the want of an author's final supervision is a severe injury to any work. Secondly, the author seems to have had to depend almost entirely on his own resources. In any but the very smallest district, it is nearly impossible for one man to know the whole of it, and this is quite impossible, even after a twenty years' residence, in a group of islands like the scene of Dr. Saxby's labours. He himself lived in the most northerly of those which are inhabited, and his connection by marriage with the influential family of Edmonston—which has produced so many gifted members—no doubt gave him unusual facilities for becoming acquainted with the peculiarities of Unst; but his professional duties in a great measure tethered him to one spot, and hindered him from carrying on his investigations in the more southern islands as he unquestionably would have liked to do. Thirdly, the author does not seem to have fully appreciated what the duties of a local naturalist in these days are. Twenty years ago even this book would have attained for him a very high rank among his brethren, but times have changed. So great is the advance in all branches of biology, that what then passed for the best of work is now far behind the age. The

\* Germany is of course the only one which can compare with Britain in this respect; and leaving out of consideration the difference in extent of the two countries, there can be little doubt as to the side on which the numerical superiority lies. It is true that in Prof. Giebel's "Thesaurus Ornithologicus" the titles of British works occupy barely six pages against nine-and-a-half of German. But the latter are really collected with much amount of care, while the former, if not taken at haphazard, have been picked on some principle of artificial selection which defies inquiry. Had the British journals been examined by that learned compiler at all as closely as the German, the list of papers relating to the ornithology of the United Kingdom would have been more than doubled.

British ornithologist has become a more highly educated and better-read man than he was, and, what is more to the purpose, a man of wider views. He must not only know what are the general wants of his science at present, the problems which require solution, but, to take a good place, he must know also much more of what is being done by his neighbours than most of our forefathers in the pursuit cared to trouble themselves with. Lacking such knowledge as this, he is apt to miss the bearings of observations of the most interesting kind, and he is sure to be tediously minute upon matters which might or would have rejoiced his bird-fancying predecessors, but are of small moment to his contemporaries.

We do not write these words without pain. Every allowance must be made for the gentleman who secluded himself in the most northern of the British Islands, but many a man so placed would still have formed or kept up such an intercourse with the centres of thought and investigation as to enable him to be on a level, as to their results, with the best thinkers and investigators. Shetland, nowadays, in regard to communication, is hardly further removed from Edinburgh (or, for the matter of that, from London) than Selborne was in those of Gilbert White. Yet we find that White was in the front rank of the naturalists of his time, corresponding freely, frequently and on equal terms with the acknowledged heads of his vocation, testing by his own experience all that he learned from them, and, moreover, all that was known of the labours of foreign naturalists. *Maximis haud impar*, he criticised alike Linnaeus, Scopoli and Kramer, Ray, Derham and Stillingfleet; and his criticisms are still defensible. Now, there is no evidence that Dr. Saxby did anything of this kind—an examination of his book gives no intimation that he was at all aware of what subjects were moving his brother ornithologists, whether at home or abroad. Most of his observations as they were made were transmitted for publication to a periodical which has been the delight of bird's-nesting and moth-pinning schoolboys, but, except in encouraging a taste for natural history among amateurs, it has been remarkable for persistently checking its scientific study. We do not of course blame Dr. Saxby for not occupying himself with species-splitting, nomenclature and such like refinements. They are only to be indulged in with profit by such as have ready access to museums and libraries, and are possibly not worth half the trouble that is taken about them by men who enjoy those facilities. But there were numberless subjects which were within his grasp, and yet are entirely overlooked by him. We may instance the many contested points as to the assumption of certain plumages by certain sea-fowls. A keen observer so favourably situated as Dr. Saxby, one would think, would have thrown some light on such questions. One of them relates to the various garb in which the bird, commonly known as Richardson's Skua, presents itself. The species is abundant, as everyone knows, in the Shetland seas; but not a word is vouchsafed to bring us nearer to an understanding of the matter. We are told, indeed, that parti-coloured birds and whole-coloured birds can be distinguished from the time that they are in the nest; but that much some of us knew before, either from our own experience or the testimony of others. Puzzles too, which, though perhaps

seldom discussed in public, have often been debated when two or three ornithologists are gathered together, are equally left without a word, while a word from Dr. Saxby would have been of the greatest value. Among such is that of the growth of the Puffin's monstrous bill. We have a very well told tale of the author's visit to a Puffin-warren on Hermaness, but it is just such an one as anybody not a naturalist would write, and contains nothing that dozens or scores of British ornithologists did not know before. Again, we may instance the migration of birds. An observer in such a look-out station as the extreme north of Shetland might, one would think, have furnished an infinite number of facts bearing on this important and perplexing question. Dr. Saxby contents himself with telling us when certain species come and go—very valuable information, no doubt, from so competent an authority; but as to the application of such facts, the impression they made as a whole upon his mind, their relation to similar observations in other places, not a word, so far as we can find, is said. Some of the Shetland migrants, we happen from other sources to know, touch the islands as their extreme western, others as their extreme eastern, limit; but this is all one to our author, who does not seem to care whence the wanderers come or whither they go; they are regarded by him as "the wind that bloweth where it listeth."

But enough of this unpleasing task. With the most sincere regret for Dr. Saxby's misfortunes and untimely fate, and a heartfelt sympathy with those who have to mourn his loss, we are compelled to say so much. The old adage *de mortuis* is very well in its way, but when we have him termed by reviewers "one of the first of our ornithologists," his book "a most valuable contribution to the ornithology of Great Britain," and all the rest of it, we must, if we speak at all, speak the truth. We could count at least a score of British ornithologists who, had their lot been cast in the Shetland Islands, would probably have done much better, and would certainly not have been contented to do so little. His intellectual and scientific capacity is reflected in his editor, who sees in the conductor of a popular magazine one "who has for so many years sat at the focal point" of ornithology—a metaphorical expression to which many meanings might be attached, one of which (though obviously not that of the writer) is that a focus may be found on a blank surface which receives rays of light and does not return them. The "Birds of Shetland" is a book of fair mediocrity. The next faunist, whose work we may be called on to review, will, we hope, take warning by its deficiencies, though for truthful observation—strictly limited, we must say, to observation—he cannot have a better model than Dr. Saxby. More, however, is expected of a faunist in these days.

#### MARSH'S "MAN AND NATURE"

*The Earth as Modified by Human Action.* A new edition of "Man and Nature." By George P. Marsh. (Sampson Low and Co., 1874.)

AMONG the varied forms of energy by which the ceaseless changes of the earth's surface are produced—subterranean heat, air, rain, frosts, rivers, glaciers, the sea, and the rest—the geologist requires to include as a

not unimportant agent, Life, both vegetable and animal. Some of the ways in which plants act in augmenting or retarding the operation of the inorganic forces are familiar enough. How often, for instance, do we see the walls of a ruin which have been split or cast down by the growing roots of some sapling tree which has found a footing in their masonry. The frosts and storms of winter would have levelled the walls in the end, but their action has been anticipated by the tree. Again, as an everyday example of the opposite kind of action, we may take the way in which the matted roots of trees which grow along the alluvial margin of a river serve to bind the loose sands or clays of the bank together, and retard the wasting effects of the current. Animals, too, have their own ways of effecting similar results, as every observant rambler in the country can testify. Moles, rabbits, and other burrowing animals lay bare the soil to rain and rivulet, and where they carry on their operations in loose materials liable to be dispersed by wind, as for instance on the sand-dunes by the sea, they may lead to the destruction of much valuable land under the drifting sand which they have uncovered. If we travel into other parts of the globe we find other and better examples, as in the dams of the beaver and the reefs of the coral-polyps. Less easily definable, but probably far more important, are the influences of life upon climate; for although the distribution of the fauna and flora of any region is in great measure regulated by climate, it is no less true that climate is modified by the flora, as is shown by the desiccation of countries which, once green and fertile, have been stripped of their woods.

So long as man remained in the savage state his influence resembled, and in some respects fell short of, that of the terrestrial animals who were his contemporaries. He felled a tree here and there, and when he had learned the use of grain, turned moorland into rude fields for culture. But his warfare lay not with the inanimate surface, but mainly with the beasts, fowls, and fish on which he chiefly depended for food and clothing. With the slow development of civilisation his influence as a geological agent has steadily increased, until now it must be ranked in the first class of the forces by which the surface of the land is modified. The time is yet too short during which accurate registers have been kept to admit of any very precise determination of the amount, sometimes even of the nature, of the changes effected by human action. But enough has been recorded to justify the attempt to indicate at least the general tendency of man's operations, while at the same time tolerably definite information exists regarding the results of some of his interferences with the ordinary economy of nature. In some respects man's influence is antagonistic to nature's usual modes of working, but of course, viewed broadly, it cannot do more than alter the balance of forces, giving to some a greater and to others a less share of work than in a natural state would be accomplished by them.

Mr. Marsh's "Man and Nature," published eleven years ago, was the first attempt, at least in English, to take a general view of this subject from a wide basis of reading. A work of research and generalisation from the labours of others rather than of original observation, it called attention to a field of inquiry too little cultivated by geologists. In fact, to its influence we may with pro-

bability ascribe the greater prominence now given in treatises of Physical Geography and Geology to the geological aspects of man's position on the globe. A new edition shows that the efforts of the author have not been wholly unappreciated here by that general reading public, not of professed savans, but of educated, observing men, to whom they were addressed. He must be gratified also to find that as his materials were in large measure derived from the observations of foreign writers, his work has met with a special measure of notice and approval on the Continent. It is frequently cited by recent French and German authors in Physical Geography and Geology, and a special Italian edition of it has lately been published under the author's supervision.

Of a book which has now established its position it is not necessary to say anything by way of criticism. This new edition has been somewhat enlarged, but the same division of subjects is retained. The author, who, besides being familiar with the characteristics of large tracts of his own country, the United States, has travelled extensively in Europe, brings his work abreast of the most recent discoveries and conjectures. The extent of his reading, remarkable enough in the first edition, is evinced again in this new issue. He seems to have come across the most out-of-the-way blue-book of the most out-of-the-way kingdom, and it has yielded to him some apposite illustration or suggestive fact. And even though we may be disposed to admire more the wonderful industry of research than the judgment in the selection of evidence, we cannot read even the most doubtful bits of testimony cited and commented upon without being made to think about what we may perhaps have noticed ourselves but never really reflected upon before. And there could hardly be a greater merit in a book than this. As to the change of title in this new edition, we are inclined to think it a mistake, for two reasons. In the first place, it is not in itself so good a title as the first; and in the second, the changes in the present edition are not sufficient to warrant the dropping of the name by which the book is generally known. This, however, is a small matter, and will not, we hope, damage the progress of a treatise which certainly ought to be one of the standard works of reference in the library of every well-educated Englishman.

#### BRINKLEY'S ASTRONOMY

*Brinkley's Astronomy.* Revised and partly re-written, with additional chapters, by John William Stubbs, D.D., Fellow and Tutor of Trinity College, and Francis Brinnow, Ph.D., late Astronomer Royal of Ireland, and Professor of Astronomy in the University of Dublin. (London : Longmans and Co., 1874.)

DR. BRINKLEY'S treatise on elementary astronomy, of which this is a new and revised edition, has been for many years one of the recognised text-books provided for the use of Trinity College, Dublin. We believe, however, that it is a work comparatively little known out of Ireland, and probably many English astronomers were not aware of its existence till its reappearance, in a new dress, under the able guidance and direction of Dr. Stubbs and Dr. Brinnow, by whom the present edition is revised, enlarged, and partly re-written. Its popularity as

a text-book will doubtless be no longer confined to the sister island; for this treatise, although elementary in its character, contains such clear and concise explanations of some of the principal problems in astronomy, that its intrinsic merit alone will probably find for it a place among the choice volumes of every astronomical student, and also on the shelves of every astronomical library. We do not say that this "Astronomy" is all that can be desired, nor will it obviate the necessity for the employment of a more elaborate work on practical astronomy where extreme accuracy is required in the reduction of observations; but it does on the whole explain the different problems in a clear and easy manner and in popular language, without sacrificing those details which are necessary for a proper elucidation of the different problems. We should, however, have been glad if a more detailed account had been given of some of the subjects treated upon, especially in the chapter describing the instruments usually employed in making astronomical observations. The methods of determining the instrumental adjustments are sufficiently explained, but it would be of great service to amateur astronomers if examples had been given of the complete reduction of both meridional and equatorial observations, a kind of information rarely to be found in detail in astronomical treatises.

The name of Dr. Brinkley involuntarily carries us back so far into the history of modern astronomy that a doubt existed in our mind, before opening the book, that an astronomical treatise originally prepared so many years ago, even by so distinguished an astronomer, must necessarily retain much of an antiquated character, either in arrangement or material. Thanks, however, to the great practical knowledge of Dr. Brinkley, and to the editorial labours of Dr. Stubbs and Dr. Brinnow, we find the science is represented as accurately as if the work had been published now for the first time. In the days of Dr. Brinkley, directors of observatories did not consider it their duty to reduce their observations with that completeness which we are now accustomed to see. It was not till the present Astronomer Royal, Sir George Airy, was appointed to the direction of the Royal Observatory that the numerous observations of the moon and planets made at Greenwich since 1750 were reduced upon one uniform system, and of sufficient accuracy to be made available for the correction of the elements of the lunar and planetary orbits. Under these circumstances, many of the principal astronomical constants were not sufficiently determined in the early part of the present century, especially of those relating to observing astronomy, to admit of the production of a practical handbook in so satisfactory a manner as at the present day; but in all that was essential for the proper comprehension of the general planetary and lunar motions, no one had greater qualifications for such a task than the learned Bishop of Cloyne, who had himself, in addition to other researches on refraction and parallax, investigated the value of the constant of aberration from observations made with the 8-ft. circle at the observatory of Trinity College.

This introductory treatise is founded on a series of annual lectures on astronomy delivered by Dr. Brinkley before the undergraduates of Trinity College during his occupation of the Andrews Chair of Astronomy in the University of Dublin. At the request of the College

Board these lectures were afterwards published, and they have since formed an important portion of the course of study required for the College examinations. For some time it was universally felt that the book was not in keeping with the advanced state of astronomical science, and that a new and revised edition was necessary. For this purpose, the authorities of Trinity College, who naturally have a traditional respect for this treatise, were fortunate in securing so accomplished an editor as Dr. Stubbs, and the co-operation of so distinguished an astronomer as Dr. Brünnow.

Seekers after the romance and history of astronomy will find in this volume few facts recorded in this interesting branch of the science, which the editors have apparently rightly considered as forming no part of a college text-book, for "the student who has made himself so well acquainted with astronomy as to find its history interesting will easily procure for himself, from a variety of authors, all the information he can desire." There is also a very limited amount of description of the physical aspects of the larger planets. We rather regret this omission, although there may be reason for doing so, for we believe that the book would have been more generally attractive and useful had some of the results of the numerous modern observations of the physical features of Mars, Jupiter, and Saturn been given. This treatise contains, however, what is far more valuable in a text-book, and which is often slurred over in many popular astronomical works of much higher pretensions, clear and concise explanations, accompanied in many instances with the formulæ of reduction, of various astronomical subjects. Among them we may name the theories of refraction and parallax, the phenomena depending on a change of position on the earth's surface, the motions of the moon and planets in their orbits, eclipses of the sun and moon, the application of astronomy to navigation and geography, the figure of the earth, the masses of the sun and planets, &c. A very fair description of the construction and use of the transit instrument, mural circle, and equatorial is also given, sufficient in fact to enable a non-practised but intelligent observer to understand easily the necessary adjustments required in the use of these instruments. There is an omission, however, though we could scarcely expect to find it inserted, as the method is only adopted in a few of the principal observatories, but a notice of which we are inclined to think would have been acceptable to many, and would doubtless increase the value of the section on astronomical instruments. We refer to the method of automatic registration of transits on a chronograph, instead of recording them by the ordinary or "eye and ear" method. It is true that the usual manner of making a transit is sufficiently explained, but as the chronographic registration is now frequently adopted in the determination of the differences of terrestrial longitudes, as well as in the ordinary registration of transits, we shall always be glad to see a description of the chronograph in every treatise on practical astronomy.

Besides considerable alterations in the arrangement of the subjects and additions to the text made by Dr. Stubbs, Dr. Brünnow has contributed new chapters on the physical constitution of the sun and heavenly bodies, on discoveries made by means of the spectroscope, on the proper motions of the fixed stars, and on the general

advance of stellar astronomy. We need not remark more on these chapters than that the great astronomical reputation of Dr. Brünnow is a sufficient guarantee of their accuracy, and to observe that the principal results of the recent researches are given in a concise form, which makes these chapters most interesting as well as valuable reading.

We have hitherto given to this excellent treatise an almost unqualified approval, but there are one or two points of no great moment which we should like to see corrected in a future edition. Nothing offends the eye of an astronomer more than to see in an astronomical text-book errors in the orthography of well-known proper names. We have detected a few of such errors which ought to have attracted the attention of the editors if not of the printer. "Flamstead" for *Flamsteed* might reasonably be passed over in silence; but when we see "Faumalhaut" printed for *Fomalhaut*, "Fourcault," more than once, for *Foucault*, "Leomis" for *Loomis*, "Maskeline," more than once, for *Maskelyne*, we cannot avoid feeling a pang of regret that in an educational work on the science such inaccuracies should have been allowed to pass. Again, it is unfortunate that greater care was not taken to correct the distances and magnitudes of the members of the solar system, depending upon the recent alteration of the value of the solar parallax, especially as the new value of the sun's distance in miles is frequently given. The old value in miles for the velocity of light per second, 192,000, might also have been corrected for the same reason. On page 152, the value of the solar parallax determined from Foucault's experiment is  $8''\cdot86$ , not  $8''\cdot942$ , this latter value being sensibly the same as that determined finally by Mr. Stone from a comparison of the Greenwich observations of Mars at the opposition in 1862, with the corresponding observations made by Sir Thomas Maclear at the Cape and by Mr. Ellery at Williamstown, Australia.

Notwithstanding these few slight drawbacks, we do not hesitate to recommend this most excellent treatise, which is moderate in price, to all who are interested in astronomical observations and in the progress of astronomy.

#### OUR BOOK SHELF

*A Peep at Mexico.* By John Lewis Geiger, F.R.G.S. (London: Trübner and Co., 1874.)

MR. GEIGER'S book is chiefly devoted to a description of the not well known country westward of the town of Mexico. The route of his journey was from Manzanillo, on the coast of the Pacific, *viâ* Colima, Zacualco, Guadalupe, Guanajuato, and Querétaro, to the capital.

The book gives but a "peep" at Mexico, but it is a very agreeable one; for, not entirely relying on his pen to describe what he saw, the author photographed *en route*, and forty-five views illustrate his book. Although the people, their habitations, and their ways, are the principal topics on which Mr. Geiger writes, yet here and there he gives glimpses of the natural history of the country. For example, the first part of his journey from Manzanillo was along the Laguna de Cuyutlan, which runs parallel with the shore, separated from the ocean by only a narrow strip of land. "It is almost completely enclosed by mangrove jungle, which overruns the banks and creates numerous islets by its growth where the water is shallowest. . . . There is no

variety in the vegetation; mangroves monopolise all available space." The stagnant waters he describes as covered with a brownish green slime, disturbed occasionally by an alligator.

"Some spots were literally crowded with numerous varieties of ducks and teal. . . . Their cackling would often alarm a company of huge white cranes, quietly congregated on a sandbank. . . .

"On the floating islands, proud storks and sedate melancholy herons were engaged in catching and consuming their breakfast, whilst every nook of the mangrove thickets, every shallow in the lake, every log of wood on the water, was tenanted by all manner of birds, including alike the busy wagtail, the grandfatherly pelican, and the stately flamingo. As we cut the placid waters, a brace of neat sand-pipers or a swift kingfisher, scared by the snort of the engine, would suddenly emerge from the margin of the channel, and, darting ahead, be again frightened into the air almost before they had settled.

"Soaring in graceful circles far overhead, a variety of hawks view the scene from aloft, ready to pounce upon whatever appears an easy prey; whilst thousands of dark-blue glittering swallows hurry from island to island, feeding pteously on the myriads of insects that hover above the water."

The vegetation near Colima is thus described:—

"The trees are not large, but are so interwoven as to form impassable barriers, even apart from the bushes and shrubs that spring from every spot of vacant ground. Hundreds of creepers cling to every trunk, and twine round every branch, connecting by a thousand wiry threads, thickets, shrubs, and cacti—a massive bulwark of profuse vegetation, through which the axe alone can hew a way. The huge *Organo* cactus, with its tree-like stem, often 2 ft. in diameter, and 10 ft. to 15 ft. high, sends up its stiff, straight branches to a height of 30 ft. or 40 ft. from the ground, whilst the smaller species mingle in thousands with the shrubs and bushes nearer the earth. Wherever the creepers may have neglected trunk or bough, prolific parasites, gay alike with taper leaf and gorgeous blossom, hasten to perform their part in this fairy work of nature. The flowers have little scent, but their profusion of white, yellow, and red, blended with the countless shades of green, charm the eye with tints as various as they are magnificent."

Beyond the fact of mentioning lava near Colima, Mr. Geiger has made no attempt to give any geological information, and the principal physical feature noticed is that the country is much broken up by *barrancas*, narrow ravines, which sadly interfere with the making of straight roads. The book is full of interesting information about social life.

*Les Roses:—Histoire; Culture; Description.* Par Hippolyte Jamin et Eugène Forney; préface par Ch. Naudin. 60 chromolithographies d'après nature, par Grobon. 2<sup>me</sup> édition. (Paris: J. Rothschild.)

LIKE so many of our garden-flowers, the history of most of our cultivated varieties of the rose is involved in obscurity. A few species, as *Rosa centifolia* (the Cabbage Rose), *gallica*, *damascena* (the Damask Rose), *moschata* (the Moss Rose), *lutea* (the Yellow Rose), have retained their distinguishing characters; but the majority of the florist's flowers are the result of hybridisation or variation, in which all trace of their nativity is lost. The same is the case also in Western Asia, the rose which yields the famous attar of roses being of very doubtful origin, probably a form of *R. damascena*. In the work before us we have a history of the cultivation of the rose, followed by a description of the various species and varieties, with their geographical distribution; an account of the various modes of cultivation; and a history of the diseases and insect enemies to which it is liable—all embellished with very beautifully executed woodcuts. The greater part of

this handsome volume is occupied by sixty chromolithographs of well-known roses, which are triumphs of the engraver's art. The colours are so truthful, and the execution so clear and brilliant, that even in engravings coloured by hand you could scarcely obtain more accurate or beautiful illustrations. The volume is one that deserves a place on every drawing-room table.

## LETTERS TO THE EDITOR

[The Editor does not hold himself responsible for opinions expressed by his correspondents. Neither can he undertake to return, or to correspond with the writers of, rejected manuscripts. No notice is taken of anonymous communications.]

Dr. Petermann's Letters to the Presidents of the Royal Geographical Society in 1865 and 1874

THE letter from Dr. Petermann to the President of the Royal Geographical Society, dated Nov. 7, 1874, refers to what took place ten years ago, and to the two letters which he then addressed to Sir Roderick Murchison on the subject of arctic exploration, a subject on which he then, as now, assumed for himself the right of speaking as an authority. There are many geographers who feel very strongly that Dr. Petermann did great injury to the cause of arctic discovery in 1865, and it seems desirable that as he has again put himself forward as an authority, his pretensions to that character should be examined.

Captain (now Admiral) Sherard Osborn read an exhaustive paper before the Royal Geographical Society on Jan. 22, 1865, in which he advocated a renewal of arctic exploration by the route of Smith Sound. The long series of voyages in the direction of Spitzbergen had proved, by a process of induction, that the Smith Sound route was the one that should be followed; while the development, during the Franklin searches, of that system of sledge travelling with which the name of M'Clintock is associated, caused a revolution in the method of exploring, and must be looked upon in the light of a discovery. From that time it has been known that land must be the basis of polar exploration, that a real advance can only be made by following the land-ice, and that sending ships into the drifting packs between Greenland and Novaya Zemlya is a useless waste of time and money. Sir George Back, Admiral Collinson, Sir Leopold M'Clintock, Admiral Sherard Osborn, Captain Vesey Hamilton, and other arctic officers practically acquainted with the subject held that view in 1865, and they hold it now. Their opinions were based on practical experience and on the records of former voyages, and nothing has occurred since either to alter or to modify them.

Admiral Osborn's proposal was cordially supported, and there appeared to be good reason to expect that it would be unani- mously accepted; when two letters from Dr. Petermann to Sir Roderick Murchison, by causing a useless and barren discussion, had the effect of destroying these fair prospects.

Dr. Petermann has no practical knowledge whatever of the arctic regions. He is famous for having propounded a theory more than twenty years ago, and he has ever since striven to make the obstinate facts fit into it—a hopeless task. So that while he has no actual acquaintance with the polar regions, the exigencies of his theory prevent him from judging of what he reads with an unbiased mind. It was in January 1852 that the Petermann theory was first given to the world, in the form of a "Plan of Search for Sir John Franklin." The theory is that there is an open sea round the pole, caused by the Gulf Stream, and that it can be reached late in the autumn with perfect ease, by sailing north between Spitzbergen and Novaya Zemlya. He urged that Franklin's ships were beset near the coast of Siberia, and that the way to reach them was by sailing across the polar ocean during the winter.

This is the Petermann theory. It might have been very mischievous in 1852, by diverting the search from the proper direction; but fortunately it was considered absurd, and received little or no attention. Unluckily for the cause of arctic research, Dr. Petermann re-uscitated his theory in a modified form, in his two letters to Sir Roderick Murchison, in which he advocated the Spitzbergen route in 1865.

Dr. Petermann assigned eight reasons for his preference, which are easily disposed of. His first reason was that the voyage from England to the North Pole is shorter by Spitz-



bergen; a matter which may be important to a company wishing to establish a line of packets between the two points, but which has no bearing on the question of exploration. His second reason was that the Spitzbergen seas form the widest openings into the unknown region. This is one of the strongest objections to the route, for the navigation must be conducted in a drifting pack, which is fatal to a successful advance. The third reason is still more remarkable, namely, that the "Spitzbergen seas are more free of ice than any other part of the arctic regions." This assertion is diametrically opposed to the experience of all who have visited those seas. The fourth reason is that "the drift ice north of Spitzbergen offers just as much or as little impediment to navigation as the ice of Baffin's Bay." This statement is made in the face of the fact that a fleet of whalers has annually passed through the ice of Baffin's Bay for the last fifty-six years, while the pack north of Spitzbergen has never once been penetrated. The fifth assertion is that "the sea north of Spitzbergen will never be entirely frozen over, not even in winter, nor covered with solid ice fit for sledge travelling." This is possibly true, and it forms another strong objection to the Spitzbergen route, for these streams and pools of water, while making exploration by sledges impossible, would add to the danger of wintering in the pack. The sixth assertion is that from Sir Edward Parry's furthest point a navigable sea was extending far to the north, and that in  $82^{\circ} 45'$  there was a perfectly navigable sea. The assertion is the very reverse of the real fact. Parry, at his extreme point, found the ice thicker and the floes more extensive than any he had previously met with, and there was a strong yellow ice blink always overspreading the northern horizon, denoting field-ice. The seventh assertion is that "the polar region north of Spitzbergen consists of sea and not land." This is the very reason that the Spitzbergen route is the worst that can be selected, land and land-ice being essential to a real advance. The eighth and last reason is that Parry's voyage only took six months. Here is another reason against the example being followed, for a hasty voyage of that kind must fail to secure the scientific results to be obtained from arctic research.

So much for Dr. Petermann's first letter to Sir Roderick Murchison. The only point in the second letter is the argument that there will be no difficulty in boring through the polar ice-fields north of  $80^{\circ}$ , because Sir James Ross got through the extensive pack in the antarctic regions in lat.  $62^{\circ} S$ , after it had drifted and become loose for many hundreds of miles over a boundless ocean. The fallacy of this comparison was fully exposed by Admiral Collinson. "That arctic explorer pointed out that the antarctic pack was drifting away from a solid line of immovable grounded ice-cliffs, and of course left open water in its rear, because there was no moving ice further south to take its place. The exact analogy of the voyage of Sir James Ross in the south is that of Scoresby in the north. 'The antarctic pack, in lat.  $75^{\circ} S$ ., is analogous to the ice met by the whalers in the early spring in  $75^{\circ}$  to  $76^{\circ} N$ ., through which they can usually pass. The open water north of Spitzbergen is analogous to the open sea found by Ross in the south; and the polar pack which Scoresby found bounding that open water to the north, from whence the ice he had passed through had drifted, is analogous to Ross's line of impenetrable ice barrier."

Dr. Petermann finally asked for any reason, however slight, why it would not be as easy to sail from Spitzbergen to the pole and back as to go up Baffin's Bay to the entrance of Smith Sound. This is a curious instance of the way a preconceived theory destroys the power of seeing the simplest facts. The reason is clear enough, and is well known to all arctic navigators. North of Spitzbergen the sea is encumbered by a drifting pack, through which no ship has ever penetrated. In Baffin's Bay there is land-ice, along which vessels can creep while the pack drifts past. The consequence is, that whereas a fleet of whalers passes up Baffin's Bay every year, no vessel has ever gone far into the pack north of Spitzbergen.

Although these fallacies were completely exposed at the time, the letters containing them caused a barren discussion which gave the appearance of dissension among geographers, and destroyed the previously hopeful prospect of the English Government being induced to consider Capt. Osborn's proposal favourably. Unanimity was essential to success; and thus Dr. Petermann's inopportune letters had the effect of throwing back arctic discovery for ten years.

At the same time the efforts of Capt. Osborn and his fellow

arctic voyagers in 1865 bore some good fruit. His own paper is an important document, which clearly states the true principles of arctic exploration, and has been invaluable for reference. Dr. Hooker prepared a statement of some of the scientific results of an arctic expedition; and Commodore Jansen, of the Dutch Navy, contributed an admirable memoir on the discoveries and proceedings of his countrymen in the Spitzbergen seas.

Having thus seriously injured and retarded the progress of discovery, so far as England was concerned, Dr. Petermann called upon his own countrymen, with some success, to undertake arctic voyages in pursuit of his theory. Two or three such voyages were undertaken. In 1868 the *Germania* made a voyage to Spitzbergen with exactly the same result as had attended the hundreds of voyages which preceded it; and in 1869 another *Germania* followed the track of Capt. Clavering in 1823 to the Pendulum Island, on the east coast of Greenland, adding nothing whatever, so far as navigation is concerned, to our previous knowledge. Capt. Koldewey commanded both these expeditions, and he returned after being fully convinced of the fallacy of Dr. Petermann's theory, and that Smith Sound is the route for effective north polar exploration. It is much to be deplored that these gallant German explorers, who certainly might have done really good work if they had been guided by the practical experience of their predecessors in arctic navigation, should have been made to waste their energies in avoidance with a fanciful and baseless theory.

The other arctic work that has been achieved since 1865 was not undertaken under Dr. Petermann's auspices, or to prove his theories; and the results have been much more important. The Swedes have done admirable scientific work in Spitzbergen. The Norwegians, under the auspices of Prof. Mohn, of Christiania, have circumnavigated Spitzbergen and Novaya Zemlya, and revisited Wyche's Island in  $79^{\circ} N$ ., which was discovered by an English ship in 1617. Capt. Hall sailed far up Smith Sound, proving the accuracy of Admiral Osborn's views; and lastly, Lieut. Payer and Capt. Weyprecht discovered the extensive region between Spitzbergen and Novaya Zemlya, and proved the utter fallacy of Dr. Petermann's theory, which he propounded in 1852, and has since so persistently adhered to. The ice drifted with the wind, and there was no sign either of a warm current or of a navigable polar basin.

In 1872 Admiral Sherard Osborn read his second paper, again urging the renewal by England of arctic exploration by the route of Smith Sound, with the west coast of Greenland as a base. Fortunately, complete unanimity was secured, and, thanks to the tact, judgment, and perseverance of two successive Presidents of the Geographical Society—Sir Bartle Frere and Sir Henry Rawlinson—the Government has resolved to fit out a naval arctic expedition of discovery to proceed by way of Smith Sound. Success has thus at length crowned the efforts of the Society, and baseless theories have had to give place to the experience of practical men.

Yet we have been again visited by a long letter from Dr. Petermann, which, however, did not arrive until the question was settled. Its precise object is, therefore, not very apparent; but, remembering the injury done by the two previous letters in 1865, it is certainly incumbent on those who have, after much labour and watchfulness, reached the goal, to defend the ground which has been gained, even when the old opponent has become apparently harmless.

In his third letter Dr. Petermann begins by the assertion that actual exploration since 1865 has proved that there is "greater navigability in all parts of the arctic seas than was formerly supposed to exist." There is really no ground for this assertion. Our knowledge of the arctic seas previous to 1865 has not been increased to any material extent, and the amount of navigability in those seas was as well known before that date as it has become since. The voyage of Capt. Hall, satisfactory as it is, merely proved that practical arctic men were right, and that the theorists were wrong; and although it is very generous of Dr. Petermann to withdraw his opposition to the Smith Sound route, he must surely be aware that the time has now passed when that opposition would have any effect. If the voyages since 1865 have not added much to previous knowledge, they have at least had the effect of disproving a theory which has done more than anything else to retard discovery.

Most of Dr. Petermann's letter consists of a recapitulation of the work accomplished by the Norwegians on the coast of Novaya Zemlya, and by other recent voyagers, the point of which is not apparent; and of an attempt to make out that Payer and Weyprecht were not the discoverers of Franz-Joseph



Land, but that it was visited previously by Baffin and by Cornelis Roule. His arguments are not at all borne out by the authorities to which he refers. Nor will the British Government be guided by any proposals not originating from those experienced arctic officers upon whose advice they rely, so that Dr. Petermann's suggestions about sending one steamer to the west coast and another to the east coast of Greenland might have been spared.

English geographers have always fully recognised the valuable services of Dr. Petermann as a cartographer, and the important and useful work he has long done in collecting and disseminating geographical information. But at the same time it cannot be forgotten that his persistent adherence to an indefensible theory has retarded discovery, and that in 1865 his inopportune interference had a most injurious effect upon the prospects of arctic exploration from this country. That danger is at last overcome, but those who have borne the heat and burden of the day, cannot but protest against Dr. Petermann's present assumption of the position of an arctic authority and adviser.

Nov. 22

CLEMENTS R. MARKHAM

### The Present State of the Arctic Ice Barriers

In a letter from Capt. David Gray, quoted by Dr. Petermann (*NATURE*, vol. xi. p. 39), some very interesting observations on the arctic drift ice of this year's summer are recorded, which Capt. Gray regards as justifying the conclusion that "nearly the whole of the ice was driven out of the arctic basin last summer."

Capt. Gray's observations appear to be limited to the coast of Greenland. If corresponding phenomena were presented in other and distant parts of the Arctic Ocean, they must afford strong confirmation of his conclusion. I have lately returned from a summer visit to Arctic Norway, having sailed round the North Cape and into the Varanger Fjord, stopping a few days at Tromsø and halting at Hammerfest, Vardø, Vadsø, and other arctic stations, and I was much surprised at the curious difference between the climate I found there this summer and that which I previously experienced at the same season.

The following extract describes the temperature between Tromsø and Hammerfest during my first visit in July 1856:—"The weather was excessively hot. During the hottest part of the day the thermometer stood at 77° in the cabin, at 92° in the smoking saloon—a little cabin built on deck—and 108° in the sun: on shore, in the valleys, it must doubtless have been much hotter. The contrast of this glaring Italian, or I might almost say Brazilian sky, with the snow-clad rocks and glaciers dipping almost to the sea-edge, is very striking. It was a continual source of wonderment; one of the few scenes which one does not become accustomed to, but retains its novelty day after day." Such was the prevailing weather during the summer of 1856, and such is the usual summer weather of Arctic Norway from the beginning of July until a week or two after the disappearance of the midnight sun. This year it was miserably different, to the great disappointment of the ladies I ventured to pilot thus far, and vexation to myself. The contrast was strikingly shown in the course of a walk up the Tromsødal. This summer I made two excursions up this valley with a fortnight's interval. On both occasions the lower part of the valley was a mud swamp from recent snow-thaw. In 1856, three weeks earlier in the season than my second visit this year, the snow water had evaporated, leaving the path hard and dry. In 1856, the poor little Lapps were outside their huts, gasping with heat and varnished with oily perspiration; their huts were so insufferably hot that only one or two out of a party of seven or eight male travellers dared to venture inside. This year, the ladies, as well as myself, were glad to warm ourselves by sitting round the fire upon the boulders that serve as chairs. Drizzling rain and cold mists replaced the oppressive heat, the brilliant sky, and rainless summer-time of 1856.

The Duke of Roxburgh, who has spent sixteen summers in Arctic Norway (he has the Alten salmon river opening in lat. 70°), told me that the low temperature and drizzling mistiness of this summer was quite exceptional to his experience; that the summer of 1868, which was memorably cold, was not so bad as this. The usual crops of rye and potatoes were expected to fail completely this summer.

This unusual summer is the more remarkable when compared with that of England, which, judging by the abundance of the wheat crop, must at least have reached, if not exceeded, the average of mean warmth. The exceptional arctic summer must

have been due to some exceptional arctic influence. The southward drifting of large quantities of polar ice, and consequent removal of some of the barriers that stand between us and the north pole, will account for what I have described, provided the loosened ice was sufficient in quantity and eastward extension.

The North Cape, though in lat. 71°, is not visited by icebergs; the sea there, and for some distance further north, is sufficiently warmed by the Gulf Stream to remain quite open all the year through. The free northward exposure must, however, render this part of the Arctic Ocean very susceptible to the cooling influence of an unusual southward drift of polar ice, and the peculiarities of this year's summer were exactly those which such an abnormal cooling of the sea would produce. These were evidently exaggerated over the open sea a little further north. During the few fine days we had while going round the island of Magerø, the sun was visible until about 11 or 11.30 P.M., but on approaching the north horizon it dipped into a mist-bank which hung with apparent permanence over the northernmost and most distant part of the sea. As we were desirous of seeing the actual orb of the sun quite at midnight, this repeated disappearance just at the critical time was of course especially noted. I afterwards learned that on these same nights, when the midnight sun thus played at hide-and-seek with us over the Arctic Ocean, it was clearly seen by spectators further south, who had a land or near coast horizon.

These facts, in conjunction with "the important information" given by Capt. Gray, justify us, I think, in looking forward very hopefully for important results from the proposed Arctic Expedition, and afford strong reasons for avoiding any possible source of delay that might stand in the way of an early start to make full use of next summer.

W. MATTIEU WILLIAMS

### Zoological Gardens, Regent's Park

I MUST trouble you with a few words in reply to 'your correspondents "Viator" and Mr. C. Traill (vol. xi. p. 67.)

It is quite true that our gardens in the Regent's Park are "too small in area." We have for many years endeavoured to get them enlarged; but all we have succeeded in obtaining is the slip of land on the north side of the Regent's Canal, where the new North Entrance has been made. If "Viator" has any influence with the First Commissioner of Works, and can persuade him to grant us a further extension on the south side, we shall be truly grateful.

I admit also that the larger carnivora are at present badly housed, and that their dens are much too confined. This, however, will, I trust, be remedied by the erection of the new Lions' House, which will be commenced early next year.

The plan of establishing a second Garden for breeding purposes out of London was adopted by the Council some years ago, but was not found to answer. It has, however, many advantages, and may be again tried when our funds shall permit of it.

"Viator" finds great fault with our drainage. He cannot be aware that the Sanitary Authorities of the district, who have been much exercised in this matter, have pronounced us free from all blame.

Finally, I may say, without any wish to disparage the continental gardens (with all of which I am well acquainted), that none of them can vie with those of this Society in the extent, variety, and completeness of its living collection, or in the rarity of many of the objects exhibited. That this collection is appreciated by the public is fully evident from the yearly increasing number of visitors and the continual augmentation of the list of members.

As regards the remarks of Mr. Traill, I have to observe that the Society's "Proceedings" contain several papers by the Secretaries and Superintendents of the Gardens relating to points in the economy of the animals in them; and that the Prosecutor (whose office was created mainly with the hope of utilising the collection more completely in a scientific point of view) has lately devoted considerable attention to this subject, on which he will, no doubt, ultimately give us the benefit of his observations.

Dec. 1

P. L. SCLATER

### Utilisation of Aquaria

I SHALL be glad if you will allow me to use your columns as a medium of inquiry with regard to the Brighton and Manchester Aquaria. Are there any arrangements in force already, or contemplated, whereby these fine institutions can be utilised for the promotion of zoological research? If I am not mistaken, the

\* "Through Norway with a Knapsack," p. 139.

British Association, at its meeting at Bradford, appointed a committee, the function of which was to see what arrangements of this nature could be carried out. I am not aware, however, that the committee has ever made any report, or if it has arrived at any conclusion on this subject.

INQUIRER

Nov. 24

#### Discovery of Remains of Plants and Insects

I THINK I informed you about two years ago of the discovery of a bed of plants, with leaves, and a great variety of seeds, in this locality; also the wings of a Libellula, and the beak of a bird. As little interest was attracted, I have not hitherto informed you of the subsequent finding of a bed of insects—flies, gnats, and the larva and pupa of the latter, the larva in countless thousands—also the wings, in great numbers, of a variety of flies, butterflies, and one or two grasshoppers; also a wing resembling that of the Mole Cricket. There are, likewise, two or three beetles. The insects and wings are frequently associated with a very pretty Lymea, in considerable numbers, and an occasional Planorbis, both retaining a high polish. I have also noticed a solitary small white Cyclostoma in the same bed. There are, I think, two feathers among the specimens obtained. Perhaps, as some interest has been shown in a similar discovery in Scotland, some of your readers may like to be informed of this. I am much indebted to the Rev. T. G. Bonney, of St. John's College, Cambridge, to whom you referred me, for advice and encouragement in examining these beds.

Garnet Bay, Nov. 23 E. J. A' COURT SMITH

#### Sounding and Sensitive Flames

IN a letter which I have just received from Dr. A. K. Irvine, of Glasgow, my attention is drawn to a short abstract of some of his experiments with Barry's sensitive flame, which appeared in the *English Mechanic* of Dec. 15, 1871, a few months previously to the appearance in the *Journal of the Franklin Institute*, and in the *American Journal of Science*, of the description, referred to briefly in my last letter (*NATURE*, vol. xi. pp. 6 to 8), of Mr. Geyer's researches on the acoustic properties of the same flame, some particulars of which Dr. Irvine appears also to have noticed independently. The few lines in which his observations are recorded corroborate so fully the character and mode of action of the flame as now pretty perfectly established, that a short extract from them will scarcely be without interest, from the satisfactory support which it offers to the accounts and explanations that other investigators of this flame have elsewhere given in graphic terms of its appearance.

After noticing that it can be produced with an ordinary street-lamp burner (perhaps the straight quill-form, still to be met with in some streets of Glasgow, is here meant), as well as with pin-hole jets of steatite; and that whatever kind of gauze may, with slight differences of the effect, be used, the further the wire-gauze can be removed from the burner without the flame breaking or flattening (fluttering) on the gauze, the more sensitive is the flame.—Dr. Irvine continues to describe the further characters of the flame as follows:—

"4. The roaring which takes place when any sound disturbs the flame is evidently in consequence of the greater proportion of air which mixes with the gas before passing through the wire-gauze; in short, when it roars and flattens on the gauze, it is an explosive mixture that burns.

"5. If a suitable tube (for instance, a paraffin lamp chimney of proper dimensions) is placed on the wire-gauze, it will be found that a musical note is produced every time the flame is disturbed by a sound with which it sympathises.

"6. A mixture of any inflammable gas and air passing through wire-gauze, over which a suitable chimney is placed, will give a note varying in pitch with the dimensions of the chimney and size of the flame."

Proceeding on this principle, Dr. Irvine adds that he had recently constructed and patented a form of miner's safety-lamp, which, when an explosive mixture of gas and air enters it, gives an audible signal of the dangerous condition of the mine.

It may be questioned if it is quite safe to excite rapid vibrations of a gas-flame burning on the wire-gauze inside a safety-lamp placed in an explosive atmosphere; but if any vibrations of the flame that are thus produced are limited (as it appears possible to ensure, by a proper construction of the lamp) to the extremely small oscillations of a high-pitched note, then no elements of danger in this new contrivance need necessarily be

introduced or apprehended from the sounding action of the flame. In this and in other cases of their employment which have suggested themselves to experimenters on the acoustic properties of gas-flames, there seem to be hopeful promises of advantageous application of the sensitive and sounding properties that certain gas-flames possess in a very high degree. But it is to the explanation of the cause of the prostration, and to the account of the case of musical sensitiveness in Barry's wire-gauze flame when disturbed by external sounds, that it is particularly desired to direct attention in the foregoing extract from Dr. Irvine's brief description. The reason that the author assigns to them, and thence to the monitoring action of his singing safety-lamp, that increased inflammability of the burning gas-mixture is at once the source of the sensitiveness, silent or sounding, of the wire-gauze flame, and the necessary condition of the atmosphere for the alarm note sounded by the newly invented safety-lamp, is so clearly expressed and illustrated by the order of his experiments, that as regards the probable mode of action of the disturbed gas-current adopted to explain the sensitive effects observed, there can be no doubt of the correctness of Dr. Irvine's view.

The gas-current, before reaching the wire-gauze, will naturally entangle and mix with a larger quantity of air when it is disturbed, by presenting a greater surface to the air in that state than when it issues smoothly. In the latter case it is not inflected into the tortuous wave-line of many folds and curves into which it must be bent on leaving the burner and passing from a fixed jet into an atmosphere oscillating rapidly to and fro under the action of external sounds. The sound-wave of the air into which it flows thus serves to incorporate more air with the upward stream and to render the combustion of the mixture more condensed and prompt, and the appearance of the flame in consequence more contracted and boisterous than when the gas-jet burns in a surrounding atmosphere of quiescent air.

Newcastle-on-Tyne, Nov. 14

A. S. HERSCHEL

#### SCIENCE IN MUSIC

AT the first meeting of the Royal Society on Thursday evening, the 19th ult., a paper was read by Mr. A. J. Ellis, F.R.S., on "Musical Duodenics." This formed the conclusion of a series of papers (the preceding ones having been published in the *Minutes of Proceedings*) on Just Intonation and Temperament in Music.

The author explained the defects of the ordinary keyed instruments, such as the pianoforte and organ, which were limited to twelve sounds in the octave, and were now tuned by a system which he characterised as the "worst possible," every element of harmony in them being put out of tune in all keys. To produce just intonation, it was necessary to have many more than twelve sounds in the octave; and he exhibited a chart giving a classified list of seventy-eight such notes, distinguished by the ordinary musical signs, with the addition of certain other marks which defined exactly the pitch of the notes, while their respective positions in the chart gave, by simple inspection, a correct idea of their relations to each other. Mr. Ellis then stated that as the large number of notes required by correct theory became troublesome in practice, the plan had been adopted of sacrificing absolute truth in some instances, and introducing a trifling error, by which means the requisite number of notes was much reduced, while the error was so small as not to offend the ear in any sensible degree.

Having determined thus on the number of notes to be used, the practical problem arose how best to introduce them in an instrument. Many contrivances had been suggested, involving new key-boards and modes of fingering; but considering the difficulty of introducing changes of this kind, preference was given to other plans, which retained the twelve notes of the ordinary key-board. To enable such a system to be carried out, it was necessary to make choice of certain sets of twelve notes, to be used when playing in certain keys; and to furnish information to guide these selections was the chief object of the paper. Such a set of twelve notes was called by Mr. Ellis a musical *duodene*, and the chart exhibited many of these

combinations, the properties of which and their appropriateness for particular cases were easily ascertainable.

Mr. Ellis, while deprecating the introduction generally of musical performances under the guise of lectures, illustrated his propositions by showing the effect of several instruments of fixed tones, concertinas and harmoniums, tuned in different ways. Some short harmonical passages were played, first on a harmonium of the ordinary kind, secondly on another with absolutely just intonation, and thirdly on a newly-constructed harmonium tuned on Handel's plan of the old organ temperament, but with the addition of several other notes enabling music to be played in all keys, equally well in tune. These additional notes were brought into use by draw-stops, each of which made an enharmonic change in one note, as from C sharp to D flat, G sharp to A flat, and so on. The stops were arranged before commencing the piece according to the key it was in, and they could be instantly altered at any time during its progress, if required by modulation. In this instrument the major thirds (the intervals to which the ear is most sensitive) were all justly in tune, but the fifths and minor thirds were a little flat; the ear, however, tolerated these slight errors much better than the extremely discordant error of the major third in equal temperament, and the effect of the harmony as played upon it was a great improvement on that plan.

Mr. Ellis, in the course of the paper, made frequent mention of the views of Helmholtz on harmony and temperament, and illustrated them by examples.

After the reading of the paper, Dr. Pole, F.R.S., remarked that Mr. Ellis's method of treating the elements of the musical scale had much originality, and had an interesting bearing on the structure of harmony generally; its principal object appeared, however, to be, in continuation of the author's former labours, to facilitate the production of correct intonation in music, an object of much importance. He would remind the meeting what was the present state of matters in regard to this. The fact was, that at present it was but seldom possible to hear what true harmony was like, as the great majority of music-producing instruments, namely, all those with fixed tones, were deliberately and systematically tuned false, with an amount of error painful to a sensitive ear. When he, a day or two ago, put his fingers on Mr. Ellis's just harmonium, he uttered an involuntary exclamation of surprise, for he had not heard the true harmony of a common chord for some time before. The public had only two opportunities of hearing true harmony: one when a stringed quartet was played by fine players; the other when a vocal unaccompanied piece was sung by first-rate singers. In each of these, the performers, being untrammelled by the odious temperament, gave way to the dictates of their correct ears, and produced true harmony. Every person of musical taste knew well the delightful impression produced by this kind of music. In modern oratorios it was very customary to insert, as in "Elijah," for example, an unaccompanied vocal piece, which was always rapturously applauded. Yet few people thought of the cause; it was not the composition, for the same music, when played on tempered instruments, was quite another thing; it was not even the skill of the performers, which could be manifested in other ways; it was purely and simply the fact of the harmonies being in tune, which was an agreeable novelty to the ear.

On the pianoforte, where the sounds were not long sustained, the errors of the temperament were not so offensive, but on instruments with sustained tones, such as the organ and harmonium, the defects were much more prominent. In olden times musicians had more sensitive ears, and organs were tuned (as Mr. Ellis had stated in regard to Handel's organ) on a temperament which put the principal keys in good tune, and threw the defects into keys seldom or never used on an organ in those days. But since that time, as modern music, and

especially what the Germans called *Fingerfertigkeit*, had increased in popular favour, organists had made up their minds to play in all sorts of remote keys, and had demanded that the organ builders should favour this by applying the equal temperament. For show organs this course might be defended, but for church organs, where nothing was required but the use of the simplest keys, it was perfectly indefensible, as it was spoiling the tone of the organ for its ordinary use, for the sake of a purely imaginary want. The organ was half a century ago a sweet-sounding instrument; now it was a harsh, offensive one, which made attendance at church a penance to persons with musically sensitive ears. A curious proof occurred a few years ago as to the mischief the equal temperament did to the tone of an organ. Dr. Pole had to superintend the construction of two organs of tolerable size: in one he was obliged to give way to popular prejudice by having it tuned equally; in the other he pleased himself by adopting the old tuning; and although the instruments were precisely alike in other respects, and made by the same builder, the latter acquired the reputation of a peculiarly sweet-toned organ, while the former was considered a harsh tone.

It was time something was done to correct the evil, but there had been difficulties both theoretical and practical. Theoretically it had been difficult to determine what should be the exact pitch and number of the notes to be used, but he conceived Mr. Ellis had now exhausted that subject, and that for the future no person who wished to carry out plans of just intonation would find difficulty in selecting from Mr. Ellis's data, exactly such *duodenes*, or series of notes, as would answer his purpose. There were still difficulties in practice, for as it was certain that more notes than twelve must be used, the problem how to enable the player to arrange them easily was not an easy one. In this particular, however, progress was being made; Mr. Ellis had pointed out several important simplifications, and Dr. Pole especially looked on the harmonium with shifting tones now exhibited as a promising invention. It was pleasant to hope there was some practical possibility of getting music in tune.

The continued discussion of the subject of just intonation was very desirable, for the reason that practical musicians, probably from a feeling of hopelessness as to getting anything better, were beginning to consider equal temperament as a necessary evil, and to look upon its harshness with indifference. Indeed, it was to be feared that the ears of musicians were becoming actually deteriorated in sensitiveness to errors of intonation. In our best orchestras, for example, although the strings might play in tune (for our orchestral violinists had no superiors in the world), yet the wind instruments were often false; and our conductors, even the best of them, seemed callous to the cacophony. He might remark here that the efforts at producing just intonation had been hitherto confined to instruments with the pianoforte keyboard, but there was a wide field open for the improvement in this respect of orchestral wind instruments, in regard to the just intonation of which absolutely nothing had yet been done. The utmost wind instrument makers had aimed at was to make them play correctly on equal temperament; he was not aware that anybody had thought it worth while to make enharmonic distinctions in their scale.

On all these accounts Mr. Ellis's labours to improve the general knowledge of the subject were most valuable, and earned for him the gratitude of all true lovers of music.

#### THE TREE-ALOES OF SOUTH AFRICA

THE flora of Southern Africa is extremely remarkable, not merely for the number of its species and their generally very restricted range, but also for the frequent singularity of their aspect and manner of growth. In

each of these particulars the genus *Aloe* is no exception to the general rule. Many of the species are well known in cultivation, but all agree in having fleshy elongated evergreen leaves, and thick erect spikes of yellow or red flowers. Medicinally, many species (and possibly all might be) are of importance as yielding a well-known bitter drug, which is simply the juice exuded from the leaves when cut, and boiled down to a solid consistence.

The species of *Aloe* are probably only really indigenous in Southern and Eastern Africa. *A. vulgaris* is now, however, found widely distributed along the Mediterranean and in the East and West Indies, where it is cultivated as the source of the Barbados and Curaçoa aloes.\* *A. indica*, Royle, is doubtless a slight variety. Dr. Stewart mentions it as being occasionally cultivated throughout the Punjab, and says that the pulp of the leaves is eaten by poor people and in famines.† According to the same writer, the Aloe mentioned by Masson in the Punjab is a palm (*Chamærops Ritchiana*).‡ *A. lito-*

*ralis*, König, found at Cape Comorin, is believed to be a form of *A. vulgaris*, altered by the circumstances of its situation. The habit of growth in the genus varies considerably. Mrs. Barber, a well-known South African naturalist, gives the following account of the part they play in the physiognomy of the native vegetation:—

"The genus *Aloe*, Linn., has a wide range in this country, its numerous species occurring in all rocky localities throughout the land; wherever rocks are found there are the Aloes also, cropping out (if I may be allowed the expression) with the geological formations of the country, as if they formed a part of them, decorating each knoll and cliff with their gay blossoms in great profusion and variety, from the gigantic Aloe of the Transkeian territory, which attains the height of sixty feet, and the tall, graceful, wood Aloes, to the sturdy, stout-built Aloe of the cliff, and the minute lizard-tail-like species that are scattered among the grass, each filling its peculiar locale



FIG. 1.—*Aloe dichotoma*, Linn., from Namaqualand.



FIG. 2.—*Aloe Barberi*, Dyer, from Kaffraria.

to complete the character of the landscape, and to render it truly South African in appearance."§

It may be well to mention that the true Aloes of the Old World have nothing whatever to do with the so-called "American Aloe." This is a species of *Agave*, a genus indigenous to Mexico and South America. The habit of the two genera is in many respects curiously similar, and they afford a striking instance of "homoplasy"—of the assumption by organisms essentially differing in themselves, of externally similar forms, when exposed to similar external conditions. *Aloe* commonly flowers laterally, and the growth of its main axis is therefore not arrested; *Agave*, as is generally known, flowers from its central bud, and consequently dies afterwards. *Aloe* is Liliaceous, with a superior ovary; *Agave* is Amaryllidaceous, with

an inferior one. But *Aloe*, as we have seen, has passed to the New World, and *Agave* is quite as much at home now in the Old World as its representatives are.

One is at first sight hardly prepared to hear of Aloes assuming the dimensions of trees. That they do so is, however, quite certain, though our knowledge of the arborecent species was, till quite lately, extremely imperfect, and is, indeed, still far from complete. I collected together all the material I could get access to in a paper published in the *Gardener's Chronicle* for May 2 of this year. My present object, besides that of calling the attention of the readers of NATURE to these very remarkable plants, is to correct a rather important error into which I find that I have fallen respecting them.

In point of fact, it is now pretty clear that the west and east coasts of South Africa each possess one endemic Tree-Aloe. That of the west, where it is distributed from Walvisch Bay to Clanwilliam, is *Aloe dichotoma*, Linn.

\* Flückiger and Hanbury's "Pharmacographia," p. 616.

† "Punjab Plants," p. 232. ‡ Loc. cit., p. 242.

§ Journ. Roy. Hort. Soc. New Series, vol. ii, p. 80.

well described in Paterson's "Travels in Africa" (1789), but otherwise very little known. The present Governor of the Cape, Sir Henry Barkly, has made great exertions to procure plants for Kew, and two have now arrived in this country, the largest being 8 ft. in height, but there is some doubt whether either will eventually survive the voyage.

*Aloe dichotoma* appears to attain a height of about 30 ft., with a girth of about 12 ft.\* Fig. 1 is from a photograph by Mr. Chapman, and is reproduced from the *Gardener's Chronicle*. Young plants of the *Aloe* from Kaffraria, alluded to above by Mrs. Barber, are now in cultivation at Kew. Finding that the name by which it was known belonged to another species, *A. Zeyheri*, and that it was undescribed, I renamed it *Aloe Barberæ*, in honour of Mrs. Barber, who first sent cuttings of it to this country. Fig. 2 (which is also borrowed from the *Gardener's Chronicle*) is a copy of a rough sketch sent to this country by the Rev. R. Baur, a Moravian missionary, at present

tured to characterise it as a new species under the name of *Aloe Bainesii*, on the ground that the leaves were longer, not glaucous, and not so completely crowded into a terminal tuft. The fact of the leaves being crowded into a terminal rosette, or spaced down the stem, is found to afford a character of even sectional value among the species. I was therefore rather astonished to find that when the Natal plant had fairly established itself, its rosette of leaves began to grow out. It is apparently only in old plants that the leaves are crowded into rosettes. I do not now doubt that the Kew plant of the Natal *Aloe* will eventually assume quite the same appearance as plants of the Kaffrarian one, with which I am now disposed to believe it to be identical. The name *A. Bainesii* must therefore be merged as a synonym in *A. Barberæ*. The only remaining discrepancy is with respect to the flowers. Mr. Baines believes that those of his plant were orange or scarlet. Those of the Kaffrarian plant (ample specimens of which I have recently received through the kindness of Sir Henry Barkly) appear, from a sketch made by Lady Barkly, to be rose, passing into flesh-colour.

The sketch of *A. Barberæ* from Natal (Fig. 3) is from a drawing by Mr. Sanderson, of D'Urban.

The stems of these *Aloes* must necessarily increase "exogenously" in diameter. This, no doubt, takes place in the same way as in the well-known Dragon Tree (*Dracaena Draco*).

W. T. THISELTON DYER



FIG. 3.—*Aloe Barberæ*, Dyer, from Natal.

resident in Kaffraria. He speaks of it as growing in the forests to the height of 30 ft., with a girth three feet above the ground of about 16 ft. Its dimensions are therefore about the same as those of *Aloe dichotoma*. In Mr. Baur's sketch the seed-vessels are represented, and he feared that he had made them proportionately too large.

An arborescent *Aloe* also exists in Natal. An account of this from Mr. Baines, the well-known African traveller, with a sketch of the spot where the plants occurred, was sent to Dr. Hooker with a living branch during last year. It was the subject of a communication made to the British Association at Bradford.† The appearance of the branch of the Natal plant was so different from that of the Kaffrarian, that I ven-

#### TRANSACTIONS AND PROCEEDINGS OF THE ROYAL SOCIETY OF VICTORIA

WE have received the Proceedings of the Royal Society of Victoria for the years 1870, 1871, and 1872, the issue of which has been delayed by the withdrawal of the Government grant in 1868, but through the liberality of the present Government we are glad to hear that the financial state of the Society enables the present report to be printed. We have read with great pleasure the addresses of the president, Mr. Ellery, showing that scientific knowledge is gaining ground fast in Victoria. Mr. Ellery tells us of the work at the Observatory, and that the positions of 38,305 stars have been established up to 1870. In 1868 the great reflector of 4 ft. diameter was mounted, and Mr. Ellery says that although his hopes were not fully realised, the telescope, if it does not excel, equals every other of its size. Mr. Le Sueur appears to have attacked  $\eta$  Argus and its surrounding nebula as early as possible, and in February 1870 he informs the Society that the spectrum of  $\eta$  is crossed by bright lines corresponding to *CDEF* and one beyond *F*, probably *H $\gamma$* : the principal line of nitrogen was also seen. He therefore concludes that hydrogen, nitrogen, sodium, and magnesium are indicated. No dark lines seem to have been seen with certainty, although they were suspected. Mr. Le Sueur says: "We seem driven to the conclusion that the star consists of a solid nucleus, a gaseous envelope cooler than the nucleus producing the dark lines, and a second envelope hotter than the nucleus accounting for the bright ones." We hope we shall not be quite driven to this conclusion of a solid nucleus, which seems highly improbable. A large influx of hot hydrogen or nitrogen from the nebula or other source might be sufficient to reverse the dark lines, and as this would heat the original photosphere more intensely its absorption would be reduced, accounting for the reduction in intensity of the black lines. In January 1874 we find that Mr. MacGeorge examined this star and found no bright lines, and further, that a distinct nebulosity surrounded the star, which in December 1869 appeared, according to Le Sueur, on a black background. Mr. MacGeorge furnishes several drawings of the nebula surrounding  $\eta$  which show a vast change in the shape of the mass. In 1838  $\eta$  was involved in dense nebula, while

\* By an unfortunate misprint in the *Gardener's Chronicle* (copied by Flinders and Hanbury, *loc. cit.*), 30 ft. is given as the greatest girth.  
† See *Journal of Botany*, 1873, p. 348. The sketch is reproduced in the *Gardener's Chronicle*, *loc. cit.*

in 1869 it was seen on a bare sky. The further drawings by Mr. Ellery and Mr. Le Sueur are scarcely recognisable as being made from the same nebula, so vast appears the changes; in one instance the difference between two drawings shows a motion of the gas, if motion it be, of 6,000,000,000 miles a month. We have known comets' tails or jets to have a motion comparable to this—so perhaps some similar cause is acting here. Mr. L. Sueur appears to have carefully examined the spectrum of Jupiter with the Melbourne reflector, but with no very decisive results, the absorption-lines appearing constant across the slits, which leads him to infer that the light from the different parts of the visible surfaces had passed through not widely unequal thicknesses of atmosphere, or that the least thickness was sufficient to produce a maximum absorption. Mr. Ellery has been trying paper paraffined, instead of waxed, for photographing the continuous records of magnetic and other phenomena, thereby shortening the sensitising and developing by more than an hour; but he has found that by using plain paper some four hours are saved. The process he uses is a slight modification of Crooke's. A large number of enhydros or water-stones were found at Beechworth in 1864. On the granite rock near Beechworth

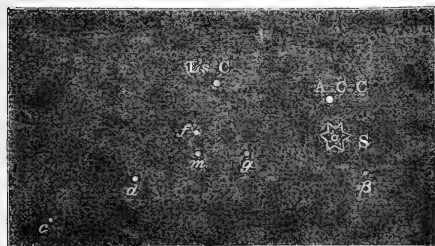

is a Silurian outlier of sandstone, intersected with veins of blue quartz, and in the widening of these veins the stones appear. They lie in nests lined with scales of chalcedony and fine clay. Mr. Dunn describes the enhydros as consisting of chalcedony, irregular in form, bounded by true planes varying in colour, from yellow and opaque to quite colourless and transparent, and their size from 5 in. diameter to the size of a split pea. The contents of the stones appear from analysis by Mr. Foord to consist of water slightly mineralised with chloride and sulphate of sodium, magnesium, calcium, and a soluble form of silicic acid. Mr. Macgeorge has been at work observing the small stars near Sirius. We copy his diagram of these stars, all of which require large optical means to render them visible: the position of Alvan Clarke's comet in January 1865 is given as  $77^{\circ} 63'$ , and that of Lassell's companion  $163^{\circ} 89'$ . We are glad to see papers on the colonial timber trees, discussing the suitability of certain trees to the climate. Amongst our English trees that thrive there, are the oak, elm, ash, walnut, willow; the larch, pines, and poplars, however, seem unsuited. The red and blue gums and the blackwood seem to be amongst the most useful indigenous trees. The poisoning of water and air in Melbourne has also been occupying the attention of the Society, and Mr. Gibbons furnishes the report with several well-executed micro-photographs of the water from sewage, and drinking water from the Yan-Zean reservoir, in which forms of life appear in abundance. Numerous other papers of interest appear in the report, and we must congratulate the Society on so good a show of research.

G. M. S.

## NOTES

THE Anniversary Meeting of the Royal Society was held on Monday last; the list of the new Council we have already given. Owing to the absence of the President from domestic affliction, the chair was occupied by the Secretary, Mr. Spottiswoode. At the dinner in the evening three members of the Government were present—Lords Carnarvon and Salisbury, and Mr. W. Hunt. Lord Carnarvon in his speech gave out "no uncertain sound" as to what he deemed the duty of Government in the matter of endowment of scientific research; he virtually agreed to all the principles which we have so long and so strenuously advocated. We may therefore hope that the money to be devoted to the new Arctic Expedition is only a first instalment of what the Government think is due by the country to the promotion of directly unremunerative research.

THE command of the Arctic Expedition will be offered to one of those officers who acquired a thorough knowledge, in former expeditions, of sledge travelling, and of the true system of bringing men healthy and cheerful through an arctic winter. Thus it is intended that the present undertaking should start with the advantage of all the practical knowledge and all the experience which was accumulated in the searches for Franklin. It will also be composed of the pick of our educated young officers, and will so combine matured experience with dash and vigour. An important position will, we have no doubt, be offered to Commander A. H. Markham, whose qualifications for the post have already been well tested.

THE Oxford Professor of Geology, Mr. Prestwich, will deliver his inaugural lecture at the Museum on Friday, December 11, at 2 P.M.

THE Cambridge Board of Medical Studies have reported to the Vice-Chancellor that they have been engaged during the present term in revising the regulations for proceedings in medicine, and are desirous of recommending some changes. The Board are of opinion that it is expedient for the University to establish examinations and grant certificates of competency in so much of state medicine as is comprised in the functions of the officers of health. The certificate given to successful candidates should testify only to their competent knowledge of what is required for the duties of an officer of health. The Board recommend the following for the subjects of examination:—

1. Physics and Chemistry. The principles of chemistry and methods of analysis, with especial reference to analyses (microscopical as well as chemical) of air and water; the Laws of Heat, and the principles of Pneumatics, Hydrostatics, and Hydraulics, with special reference to ventilation, water supply, drainage, construction of dwellings, and sanitary engineering in general.
2. Laws relating to Public Health.
3. Sanitary Statistics.
4. Origin, Propagation, Pathology, and Prevention of Epidemic and Infectious Diseases; effects of overcrowding, vitiated air, impure water, and bad or insufficient food; unhealthy occupations, and the diseases to which they give rise; water supply, and disposal of sewage and refuse; nuisances injurious to health; distribution of diseases within the United Kingdom, and effects of soil, season, and climate. The Vice-Chancellor has convened a meeting of general members of the Senate for to-day, in the Arts School, for the discussion of the report.

It will be proposed in a Convocation to be held at Oxford on the 9th of December, that a sum not exceeding 100*l.* be placed at the disposal of Dr. Rolleston, Prof. H. J. S. Smith, and the Rev. Hereford B. George, M.A., of New College, for the purpose of purchasing archeological objects relating to Prehistoric periods, to be placed in the University Museum.

THE following telegram is dated Aden, Nov. 28:—"Letters have been received from Lieut. Cameron to the 16th of May.

His party were all well. He had circumnavigated the Tanganyika Lake, and found the effluent south of Speke's Islands, which the natives reported to be Congo, identical with Livingstone's Lualaba. He hopes to reach Jellala Falls and Loanda."

SOUTH Australian papers record with the utmost satisfaction the success of Mr. John Forrest in crossing from the western coast of Australia to the Overland Telegraph, through the very heart of the only extensive region in Australia which remains unexplored. He and his companions travelled nearly 2,000 miles, keeping close to the 26th parallel of south latitude. They left Champion Bay on April 1, and reached the telegraph line on Sept. 27. Much of the territory passed over was of the poorest possible description, and for 600 miles the travellers had to force their way through a spinifex desert scantily supplied with water. They had several times to fight the natives. Mr. Forrest has narrowed down, within very moderate limits, the unexplored territory lying between the settled districts of South and Western Australia. His achievement leaves only the direct and more southern route to Perth to be traversed in order to complete the data requisite for giving to the world a fair general insight into the character of the West Australian Continent.

THE American Academy of Sciences held its half-yearly session at Philadelphia on Nov. 3, 4, and 5 last, when a number of valuable papers were read. We have only space for the titles of the more important:—"Results derived from an examination of the U.S. Weather Maps for 1872-3," by Prof. E. Loomis; "The Composite Nature of the Electric Discharge," by Prof. A. M. Mayer; "The Decay of Crystalline Rocks," by Prof. T. Sterry Hunt; "Geological Survey of Colorado," by Dr. F. V. Hayden. Dr. Hayden exhibited photographs of ruined cities and villages discovered by his party in the cañons leading into the Colorado River and upon the plains in the vicinity, supposed to have been built more than 1,000 years ago by the ancestors of the present Moquis Indians. The important fact established by these discoveries is, that there once existed in what are now the arid plains and savage gorges of South-eastern Colorado a race so far civilised that they built large cities, constructing their houses of well-hewn blocks of stone, with timber floors, well-formed windows and doorways, and smoothly plastered walls, and that they possessed the art of making glazed pottery.—"Nervous System of Limulus," by Mr. A. S. Packard, jun.; "Measuring Minute Changes in Atmospheric Pressure," by Prof. A. M. Mayer; "Effect of Wind on Sound Waves," by Prof. Joseph Henry; "Removal of Ammonia from Illuminating Gas," by Prof. B. Silliman; "Physical Measurement of the Horizontal Pendulum," and "Effect of Magnetism on Iron," by Prof. O. N. Rood; "Palæontological Evidence of the Ages of Strata," by Prof. Theodore Gill.

If adulteration in England has become one of the arts, it is certain that we are not looked down upon by all nations as being beyond compare in this nefarious practice. A large trade has hitherto existed between Aleppo and England in extract of scammony; but we are told that comparatively little is now exported. "On account of its mixture with other substances," only twenty cases in all, weighing 2,100 lbs., were shipped during the past year, the value of which was 1,680*l.*, and the whole of this came to England. In the previous year, 737 cases were exported, showing that adulteration alone is rapidly driving this article out of the import market, for the roots are produced as abundantly as ever, and are dug up and sent to England, the extract being procured from them in this country. 467 cases, weighing 93,340 lbs., and valued at 362*l.*, were shipped from Aleppo to England in 1873. Considering the bulk and weight of the roots as compared with that of the extract and the consequent increase of the cost of freight, it would seem that this exportation of the roots themselves can scarcely be a profitable trade to the

shippers, inasmuch as 467 cases are valued only at 362*l.*, while twenty cases of the extract are worth 1,680*l.*

WE learn from a report on the trade and commerce of Maine U.S., that the quantity of lobster packed in cans in the factories of the coast in 1873 was 1,600,000 lb., mostly in 1 lb. cans. In addition to these, the same firms packed at their establishments in Nova Scotia over 2,000,000 cans, making the total amount packed by Portland houses in the past year, 3,600,000 cans of lobster. Besides other products which are packed in tins in America, as well for home consumption as for exportation, green maize is one of the most important; 4,000,000 cans of this maize were packed in Maine during the past year. In California a large and increasing trade is carried on in curing or drying fruits, which at one time was done by exposure of the fruits to the air. This, however, has been superseded by the process of desiccating with a blast of hot air. By this means the fruits retain all their freshness of flavour.

THE scarcity of oysters, which is now attracting renewed public attention, is a question which intimately affects a large number of people. The point is quite as important to the public as that of the scarcity of salmon, which was taken up by the Legislature thirteen years ago. Whether, as two rival parties of theorists maintain, the failure is due to natural causes or to over-dredging, the result to the public is the same; and it will only be by some systematic investigation that the doubts will be set at rest. That unfavourable weather should be the sole cause of the scarcity of oysters, for a dozen successive years, is very hard to believe; and though it is only natural that weather should have some effect upon the produce of these bivalves, it is more probable that overdredging is equally if not more to blame. In such a case some restrictions are necessary, and these restrictions can only be enforced by the action of Parliament.

A FEW weeks ago we alluded to the suggestion made by the Government of Newfoundland for the establishment of a close time for seals. We are glad to see that our own Government are also alive to the necessity for some steps being taken to prevent the annual slaughter of thousands of young and immature and breeding seals which takes place at present. The first step will be to take the opinions of the owners of sealing vessels on the advisability of such a course, and with this object we understand that the officials of the Board of Trade have already arranged to visit the principal sealing ports of Scotland.

THE *Daily News* of Tuesday has a letter from its correspondent with the Egyptian Transit Expedition, dated Thebes, Nov. 9, from which we learn that the astronomers have located themselves on an island to the south of Karnak. So far everything has gone well, and if the weather only prove favourable the work is likely to be successful. To the east the horizon is unobstructed by anything except a distant range of hills, which cannot measure more than one angular degree.

A CORRESPONDENT,] "H. B. P.," writes to correct Dr. Petermann's statement quoted in last week's article (p. 61) that the Ashantee War "cost nine millions sterling." "The utmost cost of the Ashantee expedition," our correspondent states, and he writes from the War Department, Woolwich, "was seventeen or eighteen hundred thousand pounds, and this includes stores innumerable, which were returned unshipped, and which have depreciated but little in value." This, however, in no way invalidates the force of Dr. Petermann's statement so far as concerns the purpose for which we adduced it.

MR. J. V. JONES, of University College, London, has been elected to the Brackenbury Natural Science Scholarship in connection with Balliol College, Oxford.



The observations of the November swarm of falling stars at the several French stations had no result. It seems pretty certain that the phenomenon is now at its lowest ebb of brilliancy.

M. CHEVREUL, the director of the Paris Museum, has resigned his office owing to difficulties in the nomination of a professor. The administration and the professors have come to the conclusion that the appointment must be postponed for a year, and a *suppléant* will deliver the lectures.

THE first number of a new monthly illustrated periodical, largely devoted to science, has just appeared in Paris. It is entitled, *Revue Illustrée des Lettres, Sciences, Arts, et Industries dans les Deux Mondes*.

*Annales Telegraphiques*, a periodical issued by the French administration, but in abeyance for the last eight years, has again reappeared.

M. MARTIN, a French telegraphic engineer, has invented an engine for recording votes. The contrivance has been designed on the principle of the *sonnettes électriques*, and is exhibited in a shop in the Place Dauphine. The peculiarity is that the votes are registered and their total reckoned automatically. The invention is attracting public notice, as it is expected that the Versailles representatives will have an immense number of votes to register during the next session.

MR. ERNEST INGERSOLL, of Boston, U.S., who accompanied the party of Dr. Hayden during the past summer, as zoologist, has returned with a large quantity of specimens of natural history, which he is engaged in working up for publication. An important feature of this series consists in a very extensive collection of land and freshwater shells, a branch which has been too much neglected lately by explorers, to whom recent and fossil vertebrates have had greater attractions. Mr. Ingersoll was greatly surprised at the number and character of the molluscan forms secured in Colorado, as also their strange distribution and stations, and is confident that the facts which he has to present will be considered extremely interesting to conchologists.

AMONG the gaps that have remained unfilled in the series of reports of the Wilkes Expedition has been that on the plants collected by the party, partly in consequence of the failure of the U.S. Congress to make the necessary appropriations, and partly on account of the death of Dr. Torrey, who had charge of the phenogamous portion. This volume, however, has lately appeared, Dr. Gray having undertaken the work of Dr. Torrey after his death. That part relating to the cryptogamous plants (consisting of the mosses) had been already published in several portions—that on the mosses as prepared by Mr. W. S. Sullivan, that of the lichens by Prof. Tuckerman, and that on the algae by Professors Bailey and Harvey; and the fungi by the late Dr. Curtis and Mr. Berkeley. The volume is an imperial quarto of 420 pages of letter-press, and contains twenty-nine plates. Of this only twenty copies are on sale, to be had of Westermann and Co., New York, and at the Herbarium of Harvard University.

THE Council of the Society of Arts have arranged with Prof. McLeod, of the India Engineering College, Cooper's Hill, to deliver two lectures (on dates to be hereafter determined) during the Christmas holidays. The subject will be "The Work and Food of the Iron Horse."

A SEVERE earthquake shock was felt in Chili shortly after midnight on Sept. 26. It extended as far north as Copiapo, and south as far as Talca, and was the heaviest shock experienced since the memorable one of July 7 last year. Valparaiso, Santiago, and intermediate country were almost on the focus of

the intensity of the shock. The earthquake travelled from east to west. The temperature immediately rose two degrees and six-tenths. The night was beautifully clear. Several slight tremors were felt during the ensuing week.

THE Hastings and St. Leonards Philosophical and Historical Society, which has entered on the seventeenth year of its work, is on the whole in a healthy condition. A number of the members have undertaken to investigate the science of the neighbourhood in connection with botany, zoology, archaeology, geology, meteorology, &c., so that we may expect by and by some results of substantial value.

IT is gratifying to hear that an attempt is being made to create an interest in science in North London. A series of lectures on scientific subjects are being given in the Athenæum, Camden Road, at a very moderate price, and we hope the result will be the formation of a North London Scientific Society and Field Club, somewhat after the model of the one recently started in West London. These North London lectures we shall notify in our "Diary."

A RECENT number of the *Australian Sketcher* contains a very interesting account of the great Melbourne telescope, with which so much good work has already been done by Mr. Ellery and his staff; a series of well-executed illustrations accompany the paper. It is, as the article justly concludes, to the credit of the colony that amidst its prevalent utilitarianism it remembered and recognised the claims of science to the degree implied in the purchase and support of so noble an instrument. The telescope cost about 5,000*l.*, in addition to the sum of 1,500*l.* for the house.

WE are glad to see that Mr. W. G. Valentin's "Course of Qualitative Chemical Analysis" (Churchill) has reached a third edition.

DR. WEINHOLD'S excellent "Vorschule der Experimentalphysik," which we noticed in vol. iv. p. 158, has reached a second edition, in which the author has brought his work up to time.

"BEAUTY in Common Things" is the title of a very pretty quarto volume published by the Society for Promoting Christian Knowledge. It consists of twelve chromolithographed drawings from nature by Mrs. J. W. Whympere, with descriptive text by the author of "Life Underground." The drawings are all of the most common plants, such as the Bramble, the Wild Strawberry, Furze Blossom, Blackthorn, Mushrooms, &c.; but while perfectly faithful to nature, the arrangement and execution are so artistic as to afford genuine pleasure. The text is pleasant and informing, and altogether the book is a very beautiful Christmas present, and likely to give children into whose hands it may fall, a taste for the study of nature.

WE have received the fifth edition (dated 1875) of Dr. J. H. Bennett's very interesting book, "Winter and Spring on the Shores of the Mediterranean" (Churchill). We recommend it to those in search of a genial winter home.

FROM Liverpool comes a carefully compiled "Synopsis of an Arrangement of Invertebrate Animals in the Free Public Museum of Liverpool," by the Rev. H. H. Higgins, M.A. Prefixed is an introduction the substance of which appeared in two articles by Mr. Higgins, in NATURE, vol. iii. pp. 202 and 481.

THE Geological, Botanical, and Natural History Section of the Catalogue of the Leeds Public Library contains the names of many valuable works of reference. Some of our readers may be glad to know that access can be had at all times to any of the works mentioned in the catalogue.



THE additions to the Zoological Society's Gardens during the past week include two Great Kangaroos (*Macropus giganteus*), from New South Wales, presented by Mr. A. Nicol; two Common Boas (*Boa constrictor*), two Agoutis (*Dasyprocta?*), from St. Lucia, presented by Mr. Neville Holland; a Virginian Deer (*Cervus virginianus*), from South America, presented by Capt. E. H. Cobbett; a Gazelle (*Gazella dorcas*), from Egypt, presented by Miss Lancaster; a Common Peafowl (*Pavo cristatus*), from India, presented by the Hon. A. S. G. Canning; and a Vervet Monkey (*Cercopithecus lalandi*), from South Africa; and a Sun Badger (*Helictis moschata*), from East Asia, new to the collection.

### THE "CHALLENGER" EXPEDITION\*

DURING our southern cruise the sounding-lead brought up five absolutely distinct kinds of sea-bottom, without taking into account the rock and detritus of shallow soundings in the neighbourhood of land. Our first two soundings in 93 and 150 fathoms on the 17th and 18th of December were in the region of the Agulhas current. These soundings would have been naturally logged "greenish sand," but on examining the sandy particles with the microscope, they were found to consist almost without exception of the casts of foraminifera in one of the complex silicates of alumina, iron, and potash, probably some form of glauconite. The genera principally represented by these casts were *Miliola*, *Biloculina*, *Uvigerina*, *Planorbulina*, *Rotalia*, *Textularia*, *Bulimina*, and *Nummulina*; *Globigerina*, *Orbulina*, and *Pulvinulina* were present, but not nearly in so great abundance. There were very few foraminifera on the surface of the sea at the time. This kind of bottom has been met with once or twice before; but it is evidently exceptional, depending upon some peculiar local conditions.

From the Cape, as far south as our station in lat. 46° 16', we found no depth greater than 1,900 fathoms, and the bottom was in every case "Globigerina ooze;" that is to say, it consisted of little else than the shells of *Globigerina*, whole, or more or less broken up, with a small proportion of the shells of *Pulvinulina* and of *Orbulina*, and the spines and tests of radiolarians and fragments of the spicules of sponges.

Mr. Murray has been paying the closest attention since the time of our departure to the question of the origin of this calcareous formation, which is of so great interest and importance on account of its anomalous character and its enormous extension. Very early in the voyage he formed the opinion that all the organisms entering into its composition at the bottom are dead, and that all of them live abundantly at the surface and at intermediate depths over the *Globigerina*-ooze area, the ooze being formed by the subsiding of these shells to the bottom after death.

This is by no means a new view. It was advocated by the late Prof. Bailey, of West Point, shortly after the discovery, by means of Lieut. Broke's ingenious sounding instrument, that such a formation had a wide extension in the Atlantic. Johannes Müller, Count Pourtales, Krohn, and Max-Schultze, observed *Globigerina* and *Orbulina* living on the surface; and Ernst Hæckel, in his important work upon the Radiolaria, remarks that "we often find upon, and carried along by the floating pieces of seaweed which are so frequently met with in all seas, foraminifera as well as other animal forms which habitually live at the bottom." However, setting aside these accidental instances, certain foraminifera, particularly in their younger stages, occur in some localities so constantly and in such numbers, floating on the surface of the sea, that the suspicion seems justifiable that they possess, at all events at a certain period of their existence, a pelagic mode of life, differing in this respect from most of the remainder of their class. Thus Müller often found in the contents of the surface-net off the coast of France the young of *Rotalia*, but more particularly *Globigerina* and *Orbulina*, the two latter frequently covered with fine calcareous tubes, prolongations of the borders of the fine pores through which the pseudograda protrude through the shell. I took similar *Globigerina* and *Orbulina* almost daily in a fine net at Messina, often

\* "Preliminary Notes on the Nature of the Sea-bottom obtained by the Soundings of H.M.S. *Challenger* during her Cruise in the Southern Sea in the early part of the year 1874." By Prof. C. Wyville Thomson, F.R.S., director of the Civilian Scientific Staff on board. Read before the Royal Society, Nov. 26, 1874.

in great numbers, particularly in February. Often the shell was covered with a whole forest of extremely long and delicate calcareous tubes projecting from all sides, and probably contributing essentially to enable these little animals to float below the surface of the water by increasing their surface greatly, and consequently their friction against the water, and rendering it more difficult for them to sink."\* In 1865 and 1866 two papers were read by Major Owen, F.L.S., before the Linnean Society, "On the Surface Fauna of Mid-Ocean." In these communications the author stated that he had taken foraminifera of the genera *Globigerina* and *Pulvinulina*, living, in the tow-net on the surface, at many stations in the Indian and Atlantic Oceans. He described the special forms of these genera which were most common, and gave an interesting account of their habits, proposing for a family which should include *Globigerina*, with *Orbulina* as a sub-genus, and *Pulvinulina*, the name *Colymbites*, from the circumstance that, like the Radiolaria, these foraminifera are found on the surface after sunset, "diving" to some depth beneath it during the heat of the day. Our colleague, Mr. Gwyn Jeffreys, chiefly on the strength of Major Owen's papers, maintained that certain foraminifera were surface animals, in opposition to Dr. Carpenter and myself. † I had formed and expressed a very strong opinion on the matter. It seemed to me that the evidence was conclusive that the foraminifera which formed the *Globigerina* ooze lived on the bottom, and that the occurrence of individuals on the surface was accidental and exceptional; but after going into the thing carefully, and considering the mass of evidence which has been accumulated by Mr. Murray, I now admit that I was in error; and I agree with him that it may be taken as proved that all the materials of such deposits, with the exception, of course, of the remains of animals which we now know to live at the bottom at all depths, which occur in the deposit as foreign bodies, are derived from the surface.

Mr. Murray has combined with a careful examination of the soundings a constant use of the tow-net, usually at the surface, but also at depths of from ten to one hundred fathoms; and he finds the closest relation to exist between the surface fauna of any particular locality and the deposit which is taking place at the bottom. In all seas, from the equator to the polar ice, the tow-net contains *Globigerinae*. They are more abundant and of a larger size in warmer seas; several varieties, attaining a large size and presenting marked varietal characters, are found in the intertropical area of the Atlantic. In the latitude of Kerguelen they are less numerous and smaller, while further south they are still more dwarfed, and only one variety, the typical *Globigerina bulloides*, is represented. The living *Globigerinae* from the tow-net are singularly different in appearance from the dead shells we find at the bottom. The shell is clear and transparent, and each of the pores which penetrate it is surrounded by a raised crest, the crest round adjacent pores coalescing into a roughly hexagonal network, so that the pores appear to lie at the bottom of a hexagonal pit. At each angle of this hexagon the crest gives off a delicate flexible calcareous spine, which is sometimes four or five times the diameter of the shell in length. The spines radiate symmetrically from the direction of the centre of each chamber of the shell, and the sheaves of long transparent needles crossing one another in different directions have a very beautiful effect. The smaller inner chambers of the shell are entirely filled with an orange-yellow granular sarcode; and the large terminal chamber usually contains only a small irregular mass, or two or three small masses run together, of the same yellow sarcode stuck against one side, the remainder of the chamber being empty. No definite arrangement and no approach to structure was observed in the sarcode, and no differentiation, with the exception of round bright-yellow oil-globules, very much like those found in some of the radiolarians, which are scattered apparently irregularly in the sarcode. We never have been able to detect in any of the large number of *Globigerinae* which we have examined the least trace of pseudopodia, or any extension in any form of the sarcode beyond the shell.

Major Owen (*op. cit.*) has referred the *Globigerina* with spines to a distinct species, under the name of *G. hirsuta*. I am inclined rather to believe that all *Globigerinae* are to a greater or

\* "Die Radiolarien." Eine Monographie von Dr. Ernst Hæckel. Berlin, 1862, pp. 166, 167.

† Mr. Jeffreys desires to record his dissent from this conclusion, since (from his own observations, as well as those of Major Owen and Lieut. Palmer) he believes *Globigerina* to be exclusively an oceanic foraminifera inhabiting only the superficial stratum of the sea. (Preliminary Report of the Scientific Exploration of the Deep Sea, "Proceedings of the Royal Society," No. 121, page 443.)

less degree spiny when the shell has attained its full development. In specimens taken with the tow-net the spines are very usually absent; but that is probably on account of their extreme tenacity; they are broken off by the slightest touch. In fresh examples from the surface, the dots indicating the origin of the lost spines may almost always be made out with a high power. There are never spines on the *Globigerinae* from the bottom, even in the shallowest water. Two or three very marked varieties of *Globigerina* occur; but I certainly do not think that the characters of any of them can be regarded as of specific value.

There is still a good deal of obscurity about the nature of *Orbulina universa*, an organism which occurs in some places in large proportion in the *Globigerina* ooze. The shell of *Orbulina* is spherical, usually about 5 millimetre in diameter, but it is found of all smaller sizes. The texture of the mature shell resembles closely that of *Globigerina*, but it differs in some important particulars. The pores are markedly of two different sizes, the larger about four times the area of the smaller. The larger pores are the less numerous; they are scattered over the surface of the shell without any appearance of regularity; the smaller pores occupy the spaces between the larger. The crests between the pores are much less regular in *Orbulina* than they are in *Globigerina*; and the spines, which are of great length and extreme tenacity, seem rather to arise abruptly from the top of scattered papillae than to mark the intersections of the crest. This origin of the spines from the papillae can be well seen with a moderate power on the periphery of the sphere. The spines are hollow and flexible; they naturally radiate regularly from the direction of the centre of the sphere; but in specimens which have been placed under the microscope with the greatest care they are usually entangled together in twisted bundles. They are so fragile that the weight of the shell itself, rolling about with the motion of the ship, is usually sufficient to break off the whole of the spines and leave the papillae only projecting from its surface in the course of a few minutes. In some examples, either those in process of development, or a series showing a varietal divergence from the ordinary type, the shell is very thin and almost perfectly smooth, with neither papillae nor spines, nor any visible structure, except the two classes of pores, which are constant.

The chamber of *Orbulina* is often almost empty; even in the case of examples from the surface, which appears from the freshness and transparency of the shell to be living, it is never full of sarcodite; but it frequently contains a small quantity of yellow sarcodite stuck against one side, as in the last chamber of *Globigerina*. Sometimes, but by no means constantly, within the chamber of *Orbulina* there is a little chain of three or four small chambers singularly resembling in form, in proportion, and in sculpture, a small *Globigerina*; and sometimes, but again by no means constantly, spines are developed on the surface of the calcareous walls of these inner chambers, like those on the test of *Globigerina*. The spines radiate from the position of the centre of the chambers and abut against the insides of the wall of the *Orbulina*. In a few cases the inner chambers have been observed apparently arising within or among the sarcodite adhering to the wall of the *Orbulina*.

Major Owen regards *Orbulina* as a distinct organism, nearly allied to *Globigerina*, but differing so far from it as to justify its separation into a special subgenus. He considers the small inner chamber of *Orbulina* as representing the smaller chamber of *Globigerina*, and the outer wall as the equivalent of the large outer chamber of *Globigerina* developed in this form as an investing chamber. Count Pourtales, Max-Schultze, and Krohn, on the other hand, believe, on account of the close resemblance in structure between the two shells, their constant association, and the undoubted fact that an object closely resembling a young *Globigerina* is often found within *Orbulina*, that the latter is simply a special reproductive chamber budded from the former, and capable of existing independently. I am rather inclined to the latter view, although I think much careful observation is still required to substantiate it; and some even of our own observations would seem to tell somewhat in the opposite direction. Although *Orbulina* and *Globigerina* are very usually associated, in different localities, they are so in different proportions; and in the icy sea to the south of Kerguelen, although *Globigerina* was constantly taken in the surface-net, not a single *Orbulina* was detected. Like *Globigerina*, *Orbulina* is most fully developed and most abundant in the warmer seas.

Associated with these forms, and, like them, living on the surface and dead, and with their shells in various stages of decay

at the bottom, there are two very marked species or varieties of *Pulvinulina*, *P. menardii*, and *P. micheliniana*. The general structure of *Pulvinulina* resembles that of *Globigerina*. The shell consists of a congeries of from five to eight chambers arranged in an irregular spiral. As in *Globigerina*, the last chamber is the largest; the inner smaller chambers are usually filled with yellow sarcodite; and as in *Globigerina*, the last chamber is frequently nearly empty, a small irregular mass of sarcodite only occupying a part of the cavity. The walls of the chambers are closely and minutely perforated. The external surface of the wall is nearly smooth, and no trace of a spine has ever been detected. *Pulvinulina menardii* has a large discoidal depressed shell, in diameter consisting of a series of flat chambers overlapping one another, like a number of coins laid down somewhat irregularly, but generally in a spiral; each chamber is bordered by a distinct somewhat thickened solid rim of definite width. On the lower surface of the shell the intervals between the chambers are indicated by deep grooves. The large irregular opening of the final chamber is protected by a crescentic lip, which in some specimens bears a fringe of spine-like papillae. This form is almost confined to the warmer seas. It is very abundant on the surface, and still more so during the day, at a depth of ten to twenty fathoms in the Mid-Atlantic; and it enters into the composition of the very characteristic *Globigerina* ooze of the "Dolphine Rise" in almost as large proportions as *Globigerina*. *Pulvinulina micheliniana* is a smaller variety; the upper surface of the shell is flattened as in *P. menardii*, but the chambers are conical and prolonged downwards, so that the shell is deeper and somewhat turbinate. The two species usually occur together; but *P. micheliniana* has apparently a much wider distribution than *P. menardii*, in which the former was limited to the region of the trade-winds and the equatorial drift-current, and was found rarely, if at all, to the south of the Agulhas current; the latter accompanied us southward as far as Kerguelen Land. Both forms of *Pulvinulina*, however, are more restricted than *Globigerina*, for even *P. micheliniana* became scarce after leaving the Cape, and the wonderfully pure calcareous formation in the neighbourhood of Prince Edward Island and the Crozets consists almost solely of *Globigerina bulboides*; and neither species of *Pulvinulina* occurred to the south of Kerguelen Land.

Over a very large part of the "*Globigerina*-ooze" area, and especially in those intertropical regions in which the formation is most characteristically developed, although the great bulk of the ooze is made up of entire shells and fragments of shells of the above-described foraminifera, besides these there is frequently a considerable proportion (amounting in some cases to about twenty per cent.) of fine granular matter, which fills the shells and the interstices between them, and forms a kind of matrix or cement. This granular substance is, like the shells, calcareous, disappearing in weak acid to a small insoluble residue; with a low microscopic power it appears amorphous, and it is likely to be regarded at first sight as a paste made up of the ultimate calcareous particles of the disintegrated shells, but under a higher power it is found to consist almost entirely of "coccoliths" and "rhabdoliths." I need scarcely enter here into a detailed description of these singular bodies, which have already been carefully studied by Huxley, Sorby, Gumbel, Carter, Oscar Schmidt, Wallich, and others. I need only state that I believe our observations have placed it beyond a doubt that the "coccoliths" are the separated elements of a peculiar calcareous armature which covers certain spherical bodies (the "coccospheres" of Dr. Wallich.) The rhabdoliths are the like elements of the armature of extremely beautiful little bodies, which have been first observed by Mr. Murray, and naturally called by him "rhabdospheres. Coccospheres and rhabdospheres live abundantly on the surface, especially in warmer seas. If a bucket of water be allowed to stand over night with a few pieces of thread in it, on examining the threads carefully many examples may usually be found attached to them; but Mr. Murray has found an unfailing supply of all forms in the stomachs of Salpa.

What these coccospheres and rhabdospheres are we are not yet in a position to say with certainty; but our strong impression is that they are either algae of a peculiar form, or the reproductive gemmules, or the sporangia of some minute organism, probably an alga, in which latter case the coccoliths and rhabdoliths might be regarded as representing in position and function the "amphidisci" on the surface of the gemmules of *Spongilia*, or the spiny facets on the zygospores of many of the Desmidiaceae. There are many forms of coccoliths and rhabdoliths, and many of these are

so distinct that they evidently indicate different species. Mr. Murray believes, however, that only one form is met with on one sphere; and that in order to produce the numerous forms figured by Hrekel and Oscar Schmidt, all of which, and many additional varieties, he has observed, the spheres must vary in age and development, or in kind. Their constant presence in the surface-net, in surface-water drawn in a bucket, and in the stomachs of surface animals, sufficiently prove that, like the ooze-forming foraminiferes, the coccoliths and rhabdoliths, which enter so largely into the composition of the recent deep-sea calcareous formations, live on the surface and at intermediate depths, and sink to the bottom after death. Cocospheres and rhabdospheres have a very wide but not an unlimited distribution. From the Cape of Good Hope they rapidly decreased in number on the surface, and at the bottom as we progressed southwards. The proportion of their remains in the Globigerina ooze near the Crozets and Prince Edward Island was comparatively small; and to this circumstance the extreme clearness and the unusual appearance of being composed of Globigerina alone was probably mainly due. We found the same kind of ooze nearly free from coccoliths and rhabdoliths in what may be considered about a corresponding latitude in the north, to the west of Farøe.

Before leaving the subject of the modern chalk, it may be convenient to pass on to stations 158, 159, and 160, on March 7th, 10th, and 13th, on our return voyage from the ice. The first two of these, at depths of 1,800 and 2,150 fathoms respectively, are marked on the chart "Globigerina ooze;" and it will be observed that these soundings nearly correspond in latitude with the like belt which we crossed going southwards; the third sounding at a depth of 2,600 fathoms is marked "red clay."

According to our present experience the deposit of Globigerina ooze is limited to water of a certain depth, the extreme limit of the pure characteristic formation being placed at a depth of somewhere about 2,250 fathoms. Crossing from these shallower regions occupied by the ooze into deeper soundings, we find universally that the calcareous formation gradually passes into and is finally replaced by an extremely fine pure clay, which occupies, speaking generally, all depths below 2,500 fathoms, and consists almost entirely of a silicate of the red oxide of iron and alumina. The transition is very slow, and extends over several hundred fathoms of increasing depth; the shells gradually lose their sharpness of outline and assume a kind of "rotten" look and a brownish colour, and become more and more mixed with a fine amorphous red-brown powder, which increases steadily in proportion until the lime has almost entirely disappeared. This brown matter is in the finest possible state of subdivision, so fine that when, after sifting it to separate any organisms it might contain, we put it into jars to settle, it remained for days in suspension, giving the water very much the appearance and colour of chocolate.

In indicating the nature of the bottom on the charts, we came, from experience and without any theoretical consideration, to use three terms for soundings in deep water. Two of these, Gl. oz. and r. cl., were very definite, and indicated strongly marked formations, with apparently but few characters in common; but we frequently got soundings which we could not exactly call either "Globigerina ooze" or "red clay;" and before we were fully aware of the nature of these we were in the habit of indicating them as "grey ooze" (gr. oz.) We now recognise the "grey ooze" as an intermediate stage between the Globigerina ooze and the red clay; we find that on one side as it were of an ideal line, the red clay contains more and more of the material of the calcareous ooze, while on the other the ooze is mixed with an increasing proportion of "red clay."

Although we have met with the same phenomenon so frequently that we were at length able to predict the nature of the bottom from the depth of the sounds with absolute certainty for the Atlantic and the Southern Sea, we had perhaps the best opportunity of observing it in our first section across the Atlantic, between Tenerife and St. Thomas. The first four stations on this section, at depths from 1,525 to 2,220 fathoms, show Globigerina ooze. From the last of these, which is about 300 miles from Tenerife, the depth gradually increases to 2,740 fathoms at 500, and 2,950 fathoms at 750 miles from Tenerife. The bottom in these two soundings might have been called "grey ooze;" for although its nature has altered entirely from the Globigerina ooze, the red clay into which it is rapidly passing still contains a considerable admixture of carbonate of lime.

The depth goes on increasing to a distance of 1,150 miles from Tenerife, when it reaches 3,150 fathoms; there the clay is pure and smooth, and contains scarcely a trace of lime. From this great depth the bottom gradually rises, and with decreasing depth the grey colour and the calcareous composition of the ooze return. Three soundings in 2,050, 1,900, and 1,950 fathoms on the "Dolphin Rise," gave highly characteristic examples of the Globigerina formation. Passing from the middle plateau of the Atlantic into the western trough with depths a little over 3,000 fathoms, the red clay returned in all its purity; and our last sounding in 1,420 fathoms before reaching Sombrero, restored the Globigerina ooze with its peculiar associated fauna.

This section shows also the wide extension and the vast geological importance of the red clay formation. The total distance from Tenerife to Sombrero is about 2,700 miles. Proceeding from east to west, we have

About 50 miles of volcanic mud and sand,

" 350 " Globigerina ooze,

" 1,050 " red clay,

" 330 " Globigerina ooze,

" 850 " red clay,

" 40 " Globigerina ooze;

giving a total of 1,900 miles of red clay to 720 miles of Globigerina ooze."

(To be continued.)

## SCIENTIFIC SERIALS

The *Journal of the Chemical Society* for October commences with a paper, by Prof. Roscoe, on a new chloride of uranium. The new compound is the pentachloride  $UCl_5$ , obtained by passing chlorine over a heated mixture of any oxide of uranium and charcoal. If the current of chlorine is slow, the substance forms dark needle-shaped crystals with a green metallic lustre and ruby red by transmitted light. When the chlorine is passed rapidly,  $UCl_5$  is formed as a brown powder. The compound decomposes on heating into the tetrachloride and free chlorine.—The next paper is on suberone, by C. Schorlemmer and R. S. Dale. This body is formed by distilling suberic acid with lime according to the equation—

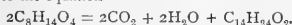

Hexane is produced at the same time, and can be separated by fractional distillation. Pure suberone is a mobile liquid, boiling at  $179^\circ$  to  $181^\circ$ . The molecular formula is  $C_8H_{16}O$ , and it is oxidised by nitric acid into an acid of the formula  $C_8H_{12}O_4$ . The authors have examined the barium, calcium, and silver salts of this acid. The new acid has the same composition as the pimelic acid obtained by Hlasiwetz and Grabowsky from camphoric acid, but its properties are quite different, and it has been provisionally named  $\alpha$ -pimelic acid. The authors assign the following constitutional formulae to suberone and  $\alpha$ -pimelic acid:—



Note on the crystalline forms of meconic and  $\alpha$ -pimelic acids, by Dr. C. A. Banghard.—On the action of earth on organic nitrogen, by E. C. C. Stanford. The experiments were made on mixtures of lean meat with ordinary loam-earth, and the author deduces therefrom the following conclusions:—1. Earth mixed with organic nitrogenous matter is an indifferent dryer, and, except in considerable quantity, a poor deodoriser. 2. That the mixtures continuously lose nitrogen to about the extent of 73 per cent. in five months. 3. That the loss is perhaps wholly due to decay, the nitrogen being probably evolved as ammonia. 4. That in such mixtures the earth does not act as an oxidiser, no nitrification taking place.—The remainder of the journal is devoted to abstracts from foreign periodicals, many of which have been already noticed in these columns.

*Gazzetta Chimica Italiana*, fascicolo vi., vii., and viii., October.—This part begins with a long and valuable paper by V. Koerner, entitled "Studies of the Isomerism of the bodies known as Aromatic Substances with six Carbon Atoms." This research has led the author to study the action of nitric acid on acetanilide giving rise to the formation of nitro-acetanilide, which is converted by potassium hydrate into a mixture of ortho- and

meta-nitroaniline. Para-nitroaniline from ordinary dinitrobenzene is next treated of, then the reduction of meta-nitroaniline. Iodobenzene acted upon by nitric acid yields ortho- and meta-iodo-nitrobenzene, the first of which was converted by the action of nitro-sulphuric acid into a dinitro derivative, which, on treatment with a dilute solution of potassium hydrate, is converted into the potassium salt of ordinary dinitrophenic acid, and by the action of alcoholic ammonia into ordinary dinitro-aniline. From these reactions the author concludes that this dinitro-iodobenzene has the structural formula 1 : 2 : 4. Dinitro-iodobenzene from meta-nitro-iodobenzene has been prepared and proved to be identical with the foregoing body; at the same time a small quantity of a second dinitro compound is produced, which the author considers as the iodide of the  $\beta$  dinitrophenol of Huebner and Werner. The dinitro-aniline from this body has been prepared, and the constitution 1 : 2 : 6 is assigned to it. The author next enters into the consideration of this  $\beta$  dinitrophenol—a table comparing the fusion points of this body and its derivatives with those of the compounds is given. The brominated derivatives of the aniline have been examined, and the constitution 1 : 2 : 4 assigned to the dibromo-aniline. A large section is next devoted to the three isomeric dibromo-benzenes; dichlorobenzene is also considered, and the three monobromo-toluenes. The action of bromine on the isomeric nitro-anilines has been studied, and constitutional formulæ are assigned to the resulting compounds. The author then goes on to consider the preparation of the new dinitrobenzene and the products of its transformations. The mono-nitro compound has been submitted to a similar study, and likewise the mono-nitro derivatives of the dichloro, chlorobromo, chloro-iodo, bromo-iodo, and di-iodo-benzene. The next section is devoted to the constitution of the principal substitution products of phenol. The isomeric monobromophenols are first treated of, then the following bodies in succession:—dibromo-ortho-nitroanisole, the corresponding meta compound, Laurent's bromodinitrophenol, the dinitrochlorophenol of Dubois, and the corresponding bromo- and iodo compounds; finally, dinitro-para-dibromobenzene, its phenol and aniline. The three isomeric tribromobenzenes are next treated of: nitrotribromobenzene and the products of its decomposition. The constitution of the di-derivatives is discussed, and the present state of our knowledge with respect to the ortho-, para-, and meta-series of the aromatic compounds is well displayed in a series of tables. The remainder of this paper, of which the foregoing is but an imperfect outline, is entirely devoted to theoretical considerations.—The next paper is a preliminary note on the action of hydriodic acid on santonin acid, by S. Cannizzaro and D. Amato.—This is followed by a paper by the same authors on metasantonin, to which the formula  $C_{15}H_{15}O_3$  is assigned.—Quantitative determination of the atomic group  $C_2H_5O$  contained in acetyl substitution products, by Fausto Sestini.—On the action of bromine on anhydrous chloral, by A. Oglialoro.—Allylate of chloral, by the same author.—Transformation of benzamide into benzoic aldehyde and alcohol, by Prof. J. Guareschi.—Action of sulphur on calcium carbonate, by E. Pollacci.—On the production of ozone by means of the electric discharge, by C. Giannetti and A. Volta.—On the necessity for searching for phosphorus in the urine in cases of poisoning, by F. Selmi. The same author contributes a paper on milk.—The concluding paper is by M. Mercadante, on the behaviour of tannic acid when used in agriculture.—The part concludes with notices of current foreign work in technical chemistry.

*Bulletin de la Société d'Anthropologie de Paris*, tome neuvième.—M. Dareste, in reply to the discussion which his paper on double or twin monsters (as given in a former number) had called forth, explains the nature of the observations on which his deductions were based. It would appear that after submitting nearly 8,000 hens' eggs to the process of artificial incubation, he obtained nearly 4,000 anomalies or monstrosities, but of these only about thirty were double embryos or twin monstrosities. A similar result has been observed in the case of osseous fishes; and Jacobi, who was the first to discover (in the course of the last century) the mechanism of fecundation among these fishes, had noted the proportion of twin monsters in fishes' eggs. His observations and those of Lereboullet coincide with the result obtained by M. Dareste, that while external conditions may often determine the formation of simple monsters, they are absolutely without effect in regard to the evolutions of double monstrosities.—M. M. A. Bertrand, in a communication specially addressed to the Society, has propounded the novel hypothesis

that the discovery of the manipulation of metals, as copper, tin, iron, silver, and lead, is due to Oriental peoples, with whom it was far advanced at a period when Europe was still in a state of barbarism. He, moreover, is of opinion that these arts came from a common centre by two channels, viz., the valley of the Dnieper and the valley of the Danube, in the latter of which the semi-barbarous Slavonic tribes still practise these arts very much as they first learned them from their Asiatic neighbours.—M. Hany considers, in a short paper, the value as a distinctive paleontological character of the bifid condition of the canines in the Smeermaas jaw. He had frequently before noticed a transversal flattening in other fossil crania, and since his examination of the Smeermaas jaw he has found two other examples of this from the Quaternary period.—M. Broca discusses at length the influence of humidity on the form and dimensions of fossil crania, and deduces from his observations the general conclusions that the capacity of crania varies greatly in accordance with the hygrometric condition of their walls; that in drying, after removal from a humid soil, they undergo a considerable retraction, amounting in some instances to fully twenty cubic centimetres; that the walls of fossil crania are hygrometric; and that, consequently, no comparative observations of cranial capacity have any value unless all the crania have been exhumed for a space of many months.

THE August number of the *Bulletin de la Société d'Acclimatation de Paris* opens with a list of the various animals and plants which the society is prepared to lend to its members, with a view to establishing any new or rare forms of animal or vegetable life in different parts of the country. This is an organisation which might usefully be adopted in England.—A paper by M. B. Rico shows how varieties of Salmonids may be kept in enclosed waters, and points out—as Mr. Buckland has proved in England—that salmon and trout will keep in good condition in enclosed places with a good supply of food and of running water.—Dr. Turrel, in a paper entitled "Les Oiseaux et les Insectes," combats the theory of M. Perris that birds have very little effect in checking the increase of insects. He thinks that to the indiscriminate slaughter of small birds may be traced, to a certain extent, the spread of the Phylloxera.—Mr. K. Trimen contributes an interesting paper on the animals and useful plants of the Cape of Good Hope, from which it appears that there are no mammalia indigenous to South Africa which have been employed as beasts of burden; but the colony is rich in edible animals and valuable birds.—M. Cabonnier announces the arrival from India of several specimens of three varieties of fish never hitherto brought to Europe—the *Anabas scandens* or Climbing Perch, the Telescope Fish, and the Gourami.—The Phylloxera is the object of various notes and suggestions, with the view of providing some means of ridding its progress.

*Reale Istituto Lombardo*, Rendiconti, vol. 7, fasc. viii.—Prof. Giovanni Cantoni contributes a note, "Researches on Heterogenesis." Ten years ago the Academy appointed a committee to investigate spontaneous generation, which from time to time reports its experiments. Dr. Grassi and Dr. Macagno, at Asti, have devoted themselves to the question of vinous fermentation. With saccharine solutions and new wine, they obtained the cryptogams characteristic of vinous fermentation. A certain number appeared in flasks hermetically sealed and heated for half an hour to 100°, and some occurred in flasks containing air filtered through cotton-wool, and washed both in sulphuric acid and an alkaline solution. These observers affirm that raising the temperature of wine does not destroy Pasteur's germs, owing to a special combination between the liquid and the small quantity of free oxygen remaining in the sealed vessel.—The next paper, on the limits of electrical resistance in non-conductors, is by the same author.—Prof. Giovanni Zoga gives an account of the Anatomical Museum of Pavia, which contains 638 preparations, of which 38 are complete skeletons, 26 male and 12 female, varying in age from the fetus of two months to 101 years. Most of them are Italian, though two are German, one American, one Moor, and one Egyptian. There are 200 skulls and 400 portions of different skeletons. Of these skulls only 46 are females, and although the greater part are Italian, they include representatives of the various nations of Europe, Asia, and America, and of different social grades. The author mentions peculiarities seen in the several bones, and gives measurements of the skulls.—The last article is by Dr. Guido Grassi, and is devoted to the explanation of a new reflecting balance. This is a common balance with a reflector fixed above the index. He details experiments to show the way in which it may be used,

and its advantages in the physical laboratory, since the fiftieth part of a milligramme can be estimated, by it, quicker than by the ordinary method.

## SOCIETIES AND ACADEMIES

### LONDON

**Physical Society, Nov. 21.**—Dr. J. H. Gladstone, F.R.S., president, in the chair.—Prof. Macleod described a simple arrangement he had devised for showing internal resistance in battery cells. Two tubes about half a metre long, one of which is about twice the diameter of the other, are closed at their lower ends with corks. On the corks and within the tubes rest two discs of platinum foil connected with binding screws by platinum wires passing through the corks. The plates are covered with chloride of silver and the tubes are filled with a solution of chloride of zinc. Each tube is provided with a disc of amalgamated zinc soldered to a long insulated copper wire. The discs are cut so that they nearly fit the tubes, one being exactly double the diameter of the other, and therefore exposing four times the surface to the action of the liquid. On connecting the terminals with a galvanometer, the current will be found to increase as the distance between the zinc and platinum plates is diminished by lowering the zinc plate into the tube. In order to obtain the same deflection of the galvanometer by the narrow cell, the distance between the plates must be one-fourth those of the larger ones. The apparatus may also be used to show that opposed cells of the same kind will not produce a current. For this purpose the platinum plates are connected together and the two zinc plates joined to the galvanometer. No current will flow, whatever the distance between the plates.—Mr. James Baillie Hamilton, of University College, Oxford, made a communication on the application of wind to stringed instruments. Mr. Hamilton commenced with a short history of the efforts which had been made to bring the Eolian harp under human control, and explained how he himself had taken up the matter from Mr. John Farmer on leaving Harrow School. Mr. Farmer had succeeded in getting wind to do the work of a bow upon a string by attaching a reed to the end of it, forming thus a compound string from which a few notes of great beauty could be obtained. Mr. Hamilton, in attempting to complete a perfect instrument, soon found he had undertaken an almost impossible task, from difficulties which he explained to the Society. Failing to obtain advice or assistance, either from scientific men or from the musical instrument makers, he was once more thrown upon his own resources, and, conscious both of his responsibility and difficulties, resolved to leave for a time his university career, and to investigate to the uttermost a matter on which no information could be there obtained. The results of his investigations were then shown to the Society. After two years of labour, Mr. Hamilton had not only gained experience sufficient to perform what he had undertaken, but had also discovered that by a different mode of employing the same material, *i.e.* a string and a reed, he could secure for a string the advantages it afforded by an organ-pipe in addition to those which it already possessed. Showing a pianoforte string on a sound-board, he said: "Such strings already possess certain advantages; first, simplicity of reinforcement by a common sound-board; second, economy of space; third, blending of tone; and fourth, sympathy. Can I also secure for this string the advantages of an organ-pipe—namely, first, special reinforcement; second, volume of tone; third, choice of quality; and fourth, sustained sound?" Accordingly, an open diapason pipe was proposed for imitation, and, to the general surprise, the string was made to exactly imitate it in all these respects. Another string was next sounded, representing the note of the largest organ-pipe in use, in conjunction with other notes, satisfying the hearers that not only could a string do all the work of an organ-pipe in giving volume and sweetness to the note reinforced, but could afford the exquisite sympathetic and blending power hitherto peculiar to strings. Such notes were also sounded seven octaves apart. The reinforcement corresponding to the pipe was secured by the utilisation of a node which cut off from the string a segment corresponding to the note reinforced, presenting to all appearance the phenomenon of an organ built by nature out of a string. This node being a source of motion, is also utilised for gaining quickness of speech, since a cord, acting as a damper and stretched across the nodal line of a series of strings, serves to communicate instantaneous sound from key to key. Another invention of Mr.

Hamilton's was a string which could not be put out of tune, to the great surprise of those who attempted to do so. He also exhibited a new pianoforte string, which by its purity and volume of tone showed that the results of a grand pianoforte could be obtained in a cottage instrument. Mr. Hamilton having satisfactorily answered several questions respecting possible objections, concluded by reminding the Society that it was in attempting faithfully to carry out the designs of another man that he was now in a position not only to perform what he had undertaken, but had also been permitted to bring into use a simpler, purer, and grander source of sound than had been contemplated when he laid his hand to a task which he was still engaged in perfecting.

**Anthropological Institute, Nov. 24.**—Prof. Busk, F.R.S., president, in the chair.—Col. Lane Fox exhibited and described specimens of stone implements, bows, arrows, and blowpipes from San José, Costa Rica. Mr. Charlesworth exhibited characteristic figures, carved in amalgam by Mexican miners, and a chaplet of gold and silver coins as worn by the women of Nazareth.—A brief paper by the late Mr. Cotesworth was read, on ruins in the neighbourhood of Palmyra; with Notes on some skulls found therein, by the President. The ruins described were groups of towers and tombs lying north and south of the Kuryelein road on the hills facing the castle. In one of these towers were discovered many skulls and other human remains, some of which were exhibited on the table. The date of their deposition could not, in the opinion of the author, be less than 1,500 to 2,000 years ago. There were also large underground tombs showing the same arrangements as in the towers. An examination of the remains by the President showed that they belonged to individuals of a dolichocephalic race of large rather than small stature, but by no means gigantic. A short time since Capt. Burton had forwarded skulls to the Institute presenting the same characteristics as the specimens under consideration.—Mr. W. Bollaert contributed Notes on some Peruvian antiquities, and exhibited a series of drawings and photographs in illustration, which he gave to the Institute.

### MANCHESTER

**Literary and Philosophical Society, Nov. 17.**—Edward Schunck, F.R.S., president, in the chair.—Some remarks on Dalton's first table of atomic weights, by Prof. Henry E. Roscoe, F.R.S. This has already appeared in NATURE, vol. xi. p. 52.—Action of light on certain vanadium compounds, by Mr. James Gibbons.—On basic calcium chloride, by Harry Grimshaw, F.C.S.—On the structure of Stigmara, by Prof. W. C. Williamson, F.R.S., which we hope to give next week.

### PHILADELPHIA

**Academy of Natural Sciences, July 21.**—Dr. Ruschenberger, president, in the chair.—Prof. Persifer Frazer, jun., described a coal-cutting machine, designed by Mr. James Brown, of Brazil, Indiana. It consists of a steel or iron wheel, set in a frame, connected with the pneumatic engine, which runs in rails laid parallel to the face of the heading, which in this case may be several hundred yards long. On the outer periphery of this wheel are arranged twenty or thirty triangular-shaped pieces of steel, united with it at one of their apices by a pin. In the middle of the opposite side, which is curved, are firmly-fixed chisel-steel teeth, which set themselves by friction against the coal to the proper position for cutting, as the wheel is rotated to the right or left. The motion is imparted by means of a small-toothed wheel which moves in rack-work on the under-surface of the wheel.

July 28.—Dr. Ruschenberger, president, in the chair.—On report of the committees to which they had been referred, the following papers were ordered to be published:—Description of a new species of Helix, by James Lewis, M.D.—On some Batrachia and Nematognathi, brought from the Upper Amazon by Prof. Orton, by Edward D. Cope.—Notes on American Lepidoptera, with descriptions of twenty-one new species, by Aug. R. Grote.—Determination of the Species of Moths figured in the "Natural History of New York," by Aug. R. Grote, A.M.

Aug. 4.—Dr. Ruschenberger, president, in the chair.—Mr. Thomas Meehan exhibited some branches of *Acer Pennsylvanicum*, Lin. (*A. striatum*, Lamb), which had a remarkable system of dimorphic foliage. The first pair of leaves developed after the bursting of the bud in the spring, were larger and more perfectly developed than any subsequent ones. The next pair were usually lance-linear. Occasionally there was a tendency to the production of a pair of lobes, but usually the margins were

entire or sparsely serrulated. The third and subsequent pairs of leaves partook of the form of the first pair, though seldom so large. It was worthy of remark, that in plants with alternate leaves, the leaves with their axial buds were generally about the same size. In some few instances there were variations in the size, especially in the  $\frac{1}{2}$  arrangement of the leaves on the stem. In opposite leaved plants the rule was the other way; one bud or one leaf, either in the blade or petiole, being larger or longer than the other. In the blades this was especially the case. At times the petioles in some cases would be not more than half the length of the opposite. He had found this especial peculiarity, however, in no other species but *A. Pennsylvanicum* that he had been able to examine, which included most in common cultivation. It might be in *A. spicatum*, Lam., which he had not been able to examine this season, and which he supposed to be but a variety of *A. Pennsylvanicum*.

Aug. 25.—Dr. Ruschenberger, president, in the chair.—Prof. Leidy exhibited a living specimen of the freshwater ciliated polyp, formerly described by him under the name of *Pectinatella magnifica*. Pectinatella is by far the largest of all the known freshwater ciliated polyps, and, indeed, is not surpassed by any of the marine forms known to us. It has not been determined whether the huge Pectinatella colonies start each from a single individual, or are the result of the confluence of a number of small colonies. On the approach of winter the colonies die and undergo decomposition, in which process the remarkable winter eggs or statoblasts are liberated. These are provided with anchor-like spines, by which, as in the case of the eggs of skates and sharks, they become attached to various fixed bodies. In examining various common animals of our household, Prof. Leidy had found a thread-worm infesting the common house-fly. The worm is from a line to the tenth of an inch long, and lives in the proboscis of the fly. It was found in numbers from one to three in about one fly in five. The parasite was first discovered in the house-fly of India, by the English naturalist, Mr. H. J. Carter, who described it under the name of *Filaria musca*, and suggested the opinion that it might be the source of the Guinea worm, *Filaria medinensis*, in man. Mr. Carter states that he found from two to twenty of the worms in one fly of three. Dr. Dising referred the parasite to a new genus with the name of *Habronema musca*. The singular position in which the worm lives suggests the many unsuspected places we have to search to find the parents or offspring of our own parasites.

PARIS

Academy of Sciences, Nov. 16.—M. Bertrand in the chair.—The following papers were read:—On a new class of organic compounds, the carbonyls, and on the true function of ordinary camphor, by M. Berthelot. The author classes as carbonyls the three bodies, ordinary camphor, oxide of allylene, and diphenylacetone.—Action of heat on ordinary aldehyde, by M. Berthelot.—On the capillary theory according to the Liliaceæ and the Melanthaceæ, by M. A. Trécul.—On wounds from trepanning and their dressing, by M. C. Scédlot.—Observations on the November shooting stars, by M. L. Verrier.—On the age of the Pyrenean red sandstone and relationship to the Saint-Béat statutory marble, by M. A. Leymerie.—On electric induction, by M. P. Volpicelli.—Action exercised by an electro-magnet on the spectra of rarefied gases traversed by the electric discharge, by M. J. Chautard. The author has hitherto examined only the spectra of metalloids. The magnet appears to influence the number, position, fineness, &c., of the spectral lines in a special manner for each element.—Note on magnetism and on a new exploding fuse, by M. Tréve.—On the circulatory system of the Echidnæ, by M. Edm. Perrier.—Note on the manufacture of paper from *gombo* (*Hibiscus esculentus*), and on the industrial uses of this plant, by M. Ed. Landrin.—On the relationship existing between the chemical composition of the air in the swim-bladder and the depth at which the fish are taken, by M. A. Moreau.—Unwholesomeness of the Seine in August, September, and October, 1874, by M. Boudet.—Method pursued in searching for the most efficacious substance for resisting Phylloxera at the viticultural station of Cognac, by M. Max Cornu.—Effects produced by the first frosts on the phylloxerized vines in the vicinity of Cognac, by M. Maurice Girard.—A despatch was read from the French Minister at Peking, and a letter from M. Fleuriat, announcing the safe arrival and installation of the Transit of Venus Expedition at that city.—On two points in the theory of substitutions, by M. C. Jordan.—On fluorene, by M. Ph. Barbier. The formula

for this hydrocarbon is  $C_{26}H_{16}$ . The author has examined many of its derivatives.—On the marsupium of the eye of birds, by MM. J. André and Beauregard.—New method for the antiseptic occlusion of wounds, by M. Sarazin.—On the mutability of microscopic germs and on the passive function of the organisms classed as *ferments*, by M. J. Duval.—The carboniferous limestone soil of the Pyrenees, by M. Henri Magnan.—The shooting stars of November 1874, by M. Chapelas.

Nov. 23.—M. Cl. Bernard in the chair.—The following papers were read:—Meridianal observations of the minor planets made at Greenwich Observatory (forwarded by Sir G. B. Airy, Astronomer Royal) and at the Observatory of Paris during the third quarter of the year 1874, communicated by M. Leverrier.—M. H. A. Weddell communicated a botanical note on the algolichenic theory.—Note on the gum-bearing *Acacia* of Tunis, by M. Doûmet-Adanson.—On new improvements in magneto-electric machines, by M. Z. T. Gramme.—On the saccharine matter contained in mushrooms, by M. A. Müntz.—Effects of potassium sulphocarbonate on Phylloxera, by M. Mouillefert.—M. Max Cornu presented a paper containing the continuation of his researches for the most efficacious substance for the destruction of Phylloxera.—Experiments made on branches of vine immersed in water containing various substances in solution, by M. A. Baudrimont.—Facts relating to Phylloxera and to the submersion of vines and cereals; application of M. Naudin's process to vines that cannot be submerged, by M. G. Grimaud.—On the stability of the equilibrium of a heavy body resting on a curved support, by M. C. Jordan.—Influence of temperature on the coefficient of capillary flowing of liquids, by M. A. Gueront.—On the product formed by the addition of hypochlorous acid to propylene, by M. L. Henry.—On the Actinæ of the oceanic coasts of France, by M. P. Fischer.—New researches on the organogenesis of *Lophospermum erubescens*, by M. Frémeineau.—M. E. Duchemin communicated a note concerning the invention of the circular compass.—During the meeting the perpetual secretary announced to the Academy the safe arrival at Sydney of MM. André and Angot, the members of the Transit of Venus Expedition who are to observe this phenomenon from Noumea.

BOOKS AND PAMPHLETS RECEIVED

- BRITISH.—Report of Newcastle-on-Tyne Chemical Society.—The Aerial World: G. Hartwig (Longmans).—Transits of Venus: R. A. Proctor, B.A. (Longmans).—Descent of Man (New Edition): Charles Darwin, M.A., F.R.S. (J. Murray).—Transactions of the Institute of Engineers and Ship-builders in Scotland. Report on Safety Valves.—Chambers's Information for the People (W. and R. Chambers).—The Origin of Civilisation and the Primitive Condition of Man: Sir John Lubbock, Bart., M.P., F.R.S. (Longmans).—Elements of Embryology: M. Foster, M.A., M.D., F.R.S., and F. M. Balfour, B.A. (Macmillan and Co.)
- AMERICAN.—Relation between the Barometric Gradient and the Velocity of the Wind: Wm. Ferrel, A.M. (Washington, U.S.).—Complete Works of Count Rumford, vol. iii. (Boston, U.S.).—Proceedings of the American Society of Arts and Science (John Wilson, Boston).—Proceedings of the American Philosophical Society (Philadelphia).—Annotated List of Birds of Utah: H. W. Henshaw (Salem, U.S.).—Report of Explorations of 1873 of the Colorado of the West: Prof. J. W. Powell (Washington).—Synopsis of the Flora of Colorado: T. C. Porter (Washington).
- FOREIGN.—Correspondenzblatt des Naturforscher-Vereins zu Riga.—Observaciones magneticas y Meteorologicas (Havana, Cuba).

CONTENTS

	PAGE
SAXBY'S "BIRDS OF SHETLAND" . . . . .	81
MARSH'S "MAN AND NATURE" . . . . .	82
BRINKLEY'S ASTRONOMY. . . . .	83
OUR BOOK SHELF . . . . .	84
LETTERS TO THE EDITOR.— Dr. Petermann's Letters to the Presidents of the Royal Geographical Society in 1865 and 1874.—CLEMENTS R. MARKHAM, C.B., F.R.S. . . . .	85
The Present State of the Arctic Ice Barriers.—W. MATTHEW WILLIAMS, F.R.S. . . . .	87
Zoological Gardens, Regent's Park.—P. L. SCLATER, F.R.S. . . . .	87
Utilisation of Aquaria. . . . .	87
Discovery of Remains of Plants and Insects.—E. J. A. COURT SMITH . . . . .	88
Sounding and Sensitive Flames.—Prof. A. S. HERSCHEL . . . . .	88
SCIENCE IN MUSIC. . . . .	88
THE TREE-ALDS OF SOUTH AFRICA. By Prof. W. T. THISTLETON DYER ( <i>With Illustrations</i> ). . . . .	89
TRANSACTIONS AND PROCEEDINGS OF THE ROYAL SOCIETY OF VICTORIA ( <i>With Illustration</i> ). . . . .	91
NOTES. . . . .	92
THE "CHALLENGER" EXPEDITION. By Prof. WYVILLE THOMSON, F.R.S. . . . .	95
SCIENTIFIC SERIALS . . . . .	97
SOCIETIES AND ACADEMIES . . . . .	99
BOOKS AND PAMPHLETS RECEIVED . . . . .	100

THURSDAY, DECEMBER 10, 1874

## ON THE CLASSIFICATION OF THE ANIMAL KINGDOM\*

LINNÆUS defines the object of classification as follows:—"Methodus, anima scientiæ, indigitat, primo intuitu, quodcumque corpus naturale, ut hoc corpus dicat proprium suum nomen, et hoc nomen quæcumque de nominato corpore beneficio seculi innouere, ut sic in summa confusione rerum apparenti, summus conspiciatur Naturæ ordo." (*Systema Naturæ*, ed. 12, p. 13.)

With the same general conception of classificatory method as Linnaeus, Cuvier saw the importance of an exhaustive analysis of the adult structure of animals, and his classification is an attempt to enunciate the facts of structure thus determined, in a series of propositions, of which the most general constitute the definitions of the largest, and the most special, the definitions of the smallest, groups.

Von Baer showed that our knowledge of animal structure is imperfect unless we know the developmental stages through which that structure has passed; and since the publication of his "Entwickelungs-Geschichte der Thiere," no philosophical naturalist has neglected embryological facts in forming a classification.

Darwin, by laying a novel and solid foundation for the theory of Evolution, introduced a new element into Taxonomy. If a species, like an individual, is the product of a process of development, its mode of evolution must be taken into account in determining its likeness or unlikeness to other species; and thus "phylogeny" becomes not less important than embryology to the taxonomist. But while the logical value of phylogeny must be fully admitted, it is to be recollected that, in the present state of science, absolutely nothing is positively known respecting the phylogeny of any of the larger groups of animals. Valuable and important as phylogenetic speculations are, as guides to, and suggestions of, investigation, they are pure hypotheses incapable of any objective test; and there is no little danger of introducing confusion into science by mixing up such hypotheses with Taxonomy, which should, be a precise and logical arrangement of verifiable facts.

The present essay is an attempt to classify the known facts of animal structure, including the development of that structure, without reference to phylogeny, and, therefore, to form a classification of the animal kingdom, which will hold good however much phylogenetic speculations may vary.

Animals are primarily divisible into those in which the body is not differentiated into histogenetic cells (PROTOZOA), and those in which the body becomes differentiated into such cells (METAZOA of Hæckel).

I.—THE PROTOZOA are again divisible into two groups: 1. the Monera (Hæckel), in which the body contains no nucleus; and 2. the Endoplastica, in which the body contains one or more nuclei. Among these, the *Infusoria ciliata* and *flagellata* (*Noctiluca*, e.g.), while not forsaking the general type of the single cell, attain a considerable complexity of organisation, presenting a parallel to what

happens among the unicellular Fungi and Algae (e.g., *Mucor*, *Vaucheria*, *Caulerpa*).

II.—THE METAZOA are distinguishable, in the first place, into those which develop an alimentary cavity—a process which is accompanied by the differentiation of the body wall into, at fewest, two layers, an epiblast and a hypoblast (*Gastræa* of Hæckel), and those in which no alimentary cavity is ever formed.

Among the *Gastrææ*, there are some in which the gastrula, or primitive sac with a double wall open at one end, retains this primitive opening throughout life—as the egestive aperture; numerous ingestive apertures being developed in the lateral walls of the gastrula—whence these may be termed *Polystomata*. This group comprehends the *Spongida* or *Porifera*. All other *Gastrææ* are *Monostomata*, that is to say, the gastrula develops but one ingestive aperture. The case of compound organisms in which new gastrulæ are produced by gemmation is of course not a real exception to this rule.

In some *Monostomata* the primitive aperture becomes the permanent mouth of the animal (*Archæostomata*).

This division includes two groups, the members of each of which respectively are very closely allied:—1. The *Cœlenterata*. 2. The *Scolecimorpha*. Under the latter head are included the *Turbellaria*, the *Nematoidea*, the *Trematoda*, the *Hirudinea*, the *Oligochæta*, and probably the *Rotifera* and *Gephyrea*.

In all the other *Monostomata* the primitive opening of the gastrula, whatever its fate, does not become the mouth, but the latter is produced by a secondary perforation of the body wall. In these *Deuterostomata* there is a perivisceral cavity distinct from the alimentary canal, but this perivisceral cavity is produced in different ways.

1. A perivisceral cavity is formed by diverticula of the alimentary canal, which become shut off from the latter (*Enterocæla*).

The researches of Alexander Agassiz and of Metschnikoff have shown that, not only the ambulacral vessels, but the perivisceral cavity of the *Echinodermata* are produced in this manner; a fact which may be interpreted as indicating an affinity with the *Cœlenterates* (though it must not be forgotten that the dendrocelæ *Turbellaria* and many *Trematoda* are truly "cœlenterate"), but does not in the least interfere with the fundamental resemblance of these animals to the worms.

Kowalewsky has shown that the perivisceral cavity of the anomalous *Sagitta* is formed in the same way, and the researches of Metschnikoff appear to indicate that something of the same kind takes place in *Balanoglossus*.

2. A perivisceral cavity is formed by the splitting of the mesoblast (*Schizocæla*).

This appears to be the case in all ordinary *Mollusca*, in all the polychæatous *Annelida*, of which the *Mollusca* are little more than oligomeric modifications, and in all the *Arthropoda*.

It remains to be seen whether the *Brachiopoda* and the *Polyzoa* belong to this or the preceding division.

3. A perivisceral cavity is formed neither from diverticula of the alimentary canal nor by the splitting of the mesoblast, but by an outgrowth or invagination of the outer wall of the body (*Epicalæ*).

The *Tricæla* are in this case, the atrial cavity in them being formed by invagination of the epiblast.

\* Paper read at the Linnean Society, Dec. 4, 1874, by Prof. Huxley, Sec. R.S.



*Amphioxus*, which so closely resembles an Ascidian in its development, has a perivisceral cavity which essentially corresponds with the atrium of the Ascidian, though it is formed in a somewhat different manner. One of the most striking peculiarities in the structure of *Amphioxus* is the fact that the body wall (which obviously answers to the somatopleure of one of the higher *Vertebrata*, and incloses a "pleuro-peritoneal" cavity, in the walls of which the generative organs are developed) covers the branchial apertures, so that the latter open into the "pleuro-peritoneal" cavity. This occurs in no other vertebrated animal. Kowalewsky has proved that this very exceptional structure results from the development of the somatopleure as a lamina which grows out from the sides of the body and eventually becomes united with its fellow in the middle ventral line, leaving only the so-called "respiratory pore" open. Stieda has mentioned the existence of the raphé in the position of the line of union in the adult animal. Rathke described two "abdominal canals" in *Amphioxus*; and Johannes Müller, and more recently Stieda, have described and figured these canals. However, Rathke's canals have no existence, and what have been taken for them are simply passages or semi-canals between the proper ventral wall of the abdomen and the incurved edges of two ridges developed at the junction of the ventral with the lateral faces of the body, which extend from behind the abdominal pore where they nearly meet, to the sides of the mouth. Doubtless, the ova which Kowalewsky saw pass out of the mouth, had entered into these semi-canals when they left the body by the abdominal pore, and were conveyed by them to the oral region. The ventral integument, between the ventrolateral laminae, is folded, as Stieda has indicated, into numerous close-set, longitudinal plaits which have been mistaken for muscular fibres, and the grooves between these plaits are occupied by epidermic cells, so that, in transverse section, the interspaces between the plaits have the appearance of glandular coeca. This plaited organ appears to represent the Wolffian duct of the higher *Vertebrata*, which, in accordance with the generally embryonic character of *Amphioxus*, retains its primitive form of an open groove. The somatopleure of *Amphioxus* therefore resembles that of ordinary *Vertebrata* in giving rise to a Wolffian duct by invagination of its inner surface. But the Wolffian duct does not become converted into a tube, and its dorsal or axial wall unites with its fellow in the raphé of the ventral boundary of the perivisceral cavity.

In all the higher *Vertebrata* of which the development has yet been traced, the "pleuro-peritoneal" or perivisceral cavity arises by an apparent splitting of the mesoblast, which splitting, however, does not extend beyond the hinder portion of the branchial region. But, in many *Vertebrata*, (e.g., *Holocephali*, *Ganoidi*, *Teloste*, *Amphibia*) a process of the integument grows out from the region of the hyoidean arch, and forms an operculum covering the gill-cleft. In the frog, as is well known, this opercular membrane is very large, and unites with the body wall posteriorly, leaving only a "respiratory pore" on the left side, during the later periods of the tadpole's life. Here is a structure homologous with the splanchnopleure of *Amphioxus*; while, in the thoraco-abdominal region, the splanchnopleure appears to arise by splitting of the mesoblast. Considering what takes place in *Amphioxus*, the

question arises whether the "splitting" of the mesoblast in the *Vertebrata* may not have a different meaning from the apparently similar process in the *Arthropoda*, *Annelida*, and *Mollusca*; and whether the pericardium, pleura, and peritoneum are not parts of the epiblast, as the atrial tunic is of the epiblast of the ascidians. Further investigation must determine this point. In the meanwhile, on the assumption that the "pleuro-peritoneal" cavity of the *Vertebrata* is a virtual involution of the epiblast, the peritoneal aperture of fishes becomes truly homologous with the "respiratory pore" of *Amphioxus*; and the Wolffian ducts and their prolongations, with the Müllerian ducts, are, as Gegenbaur has already suggested, of the same nature as the segmental organs of worms.

The division of METAZOA without an alimentary cavity is established provisionally, for the *Cestoidea* and *Acanthocephala*, in which no trace of a digestive cavity has ever been detected. It is quite possible that the ordinary view that these are Gastreae modified by parasitism is correct. On the other hand, the cases of the Nematoid worms and of the *Trematoda* show that the most complete parasitism does not necessarily involve the abortion of the alimentary cavity, and it must be admitted to be possible that a primitive Gregariniform parasite might become multicellular and might develop reproductive and other organs, without finding any advantage in an alimentary canal. A purely objective classification will recognise both these possibilities and leave the question open.

#### THE "TIMES" ON THE IMPORTANCE OF SCIENTIFIC RESEARCH

[IN an article which appeared in yesterday's *Times*, occasion is taken of the occurrence of the Transit of Venus to point out the great activity now being displayed by foreign nations in the prosecution of abstract scientific inquiries, and the necessity of retaining England's old pre-eminence in this respect. The article is so important as indicating the growing importance which is being attached to research, that we reproduce a great part of it in our own columns, because the considerations urged by the *Times* lead to a conclusion of no uncertain sound. As England has nobly in the past, when she was almost alone, led in the search after abstract scientific truths, it behoves her now that she is by no means alone and has to compete with rivals who have shown by their Transit expeditions and by many other signs what their opinion is on this matter, to more than redouble her old efforts, if she wishes to retain the position she has won by the accumulated work of centuries.—ED. NATURE.]

THE astronomer's point of view is by no means the only one of general interest connected with the recent Transit. We have, first of all, the remarkable spectacle of trained observers of almost all nationalities—observers sent out by England, the United States, France, Germany, Italy, and Holland—distributed among some seventy stations, some of them the most inhospitable islands of the Southern seas, engaged upon one of the most abstract inquiries which can be imagined. The anxiety of the various European and the American Governments to contribute towards the solution of the problem can perhaps best be shown by indicating the stations occupied this morning by the



various parties. The English flag floats over the observatories of three parties in the Sandwich Islands, two parties in Kerguelen's Land, one in Rodriguez, one in New Zealand, two in Egypt, and one in India; nor must we omit to mention Lord Lindsay's station in the Mauritius, though his is a private expedition. This is a goodly list, but it is surpassed in its area of distribution by the American expeditions, which occupy Vladivostok in Siberia, Tien-tsin, a station in Japan, and in the Southern seas Kerguelen's Land, the Crozets, Hobart Town, Bluff Harbour (New Zealand), and Chatham Island. France has seven stations—Campbell and St. Paul's Islands, Noumea, Pekin, Yokohama, and Saigon. Russia does not occupy any southern stations, but she makes up for this by observing at no less than thirty stations within her own territory. The German Government has equipped five southern parties, while Holland is represented at Réunion. Italy has a party in Egypt. She was to have been represented by four parties in all; but little is known of her arrangements.

The number of observed Transits has been so few that it is an easy task to contrast the present arrangements with what was done in former times. Horrox, one of the most gifted of English men of science—whose memory, we rejoice to know, will this year be appropriately, if tardily, perpetuated by a tablet in Westminster Abbey—predicted the Transit of 1639 so shortly before he observed it that there was no time, if, indeed, there had been any desire, to send observers from England. When the next Transits occurred in the following century, in the years 1761 and 1769, the expeditions were few. In the former year we had an English expedition to Sumatra and a French one to Pondicherry, neither of which reached its destination; and there was another French expedition to Tobolsk. Observations were made at many places, the unfortunate Le Gentil, the French Envoy to Pondicherry, making his on board ship. In 1769 came the celebrated voyage of Captain (then Lieutenant) Cook, in the *Endeavour*, to Otaheite, on behalf of England. The King of Denmark sent an observer to Lapland; and the French Academy despatched one to California, in addition to Le Gentil. The latter had waited at Pondicherry since 1761, hoping to make up by good fortune in 1769 for his partial want of success in 1761, but the Fates were against him.

It will be seen from this rapid statement that, so far as the number of the *personnel* is concerned, the present expeditions are beyond all precedent. This remark naturally applies much more strongly to the means of observation. Not only do modern telescopes bear the same relation to those used on former occasions as a Woolwich gun does to a smooth-bore musket, but two new instruments of inquiry have been added to the scientific stock-in-trade. This morning, if the weather has been favourable, more than a score of cameras have obtained permanent records of the black spot travelling over the sun's disc at one part or another, or during the whole time of its passage, and if the spectroscope has not been used to record the planet's contact with the sun long before the eye or photographic plate could detect her presence, and again to mark the exact instant at which she parted company with it, it is not the fault of the instrument. But it is not merely to the *personnel* nor

to the instruments employed that we wish to draw chief attention, but rather to the indications afforded that the example which England and France have of old set in promoting such inquiries is being followed by other nations, and with a most remarkable vigour and intensity of purpose. Denmark, which took no part in this morning's observations, has been replaced by the United States, Germany, Holland, and Italy, and the part played by these nations, new to this peaceful strife, is most important. The United States lead all the other nations, in respect both of the amount of money which her Government has contributed, and of the discomfort, not to say dangers, of the stations she has chosen in the Southern seas. Posts of importance which were given up as too hopelessly miserable even for enthusiastic English astronomers will be occupied by Americans. The Germans [have closely followed] England and the United States in this 'noble' competition, and although the sum contributed by the German Government is small compared with the American subsidy, the German observations made this morning in the South seas will be among the most important obtained by all the expeditions. With regard to Italy, also, there are the same signs of scientific enterprise. The spectroscope, which forms no part of the equipment of the English expeditions, was intended by her men of science to be their chief weapon of attack, and as in no country is there such a skilled body of spectroscopists as in Italy, this determination was probably not arrived at on insufficient grounds.

What, then, is the meaning of all this? It is that as the world grows older each nation as it develops, as the United States, Germany, and Italy have of late largely developed, under modern conditions, feels the necessity for taking a continual and a largely increasing share in the promotion of science even in its most abstract forms. It should be a subject of pride for us to know that in this they are but following the example set by England in former centuries, including the days "when George III. was King." If we consider the revolutions effected by science since Capt. Cook's famous expedition to observe the last Transit, we shall not be astonished that the nations are beginning to vie with each other so eagerly in its development. When Cook sailed in 1768, Watt was thirty-two years of age; in the very year of the Transit he introduced the closed cylinder, and so gave us the steam-engine of to-day in its essential point. In the same year the founders of chemistry were in their early prime. Priestley was thirty-six years of age, Cavendish thirty-eight, Black forty-one, and Lavoisier twenty-six; Dalton was three years old. What has not chemistry done for England since their time? Be it always remembered that all the work of these men was of the most abstract kind, and yet that out of it has grown insensibly a large part of England's commercial greatness. Nor is this all. There is another development of science still which must be mentioned, but which is of so recent a date that in 1769 no one whose name is now associated with one of the greatest triumphs of science was born. We refer to those discoveries that have belted our world with the electric wires which to-day, from the most distant parts of our planet's surface, will bring to Europe the results of this morning's work.

It is a proper subject of national pride that the benefits

derived by the world from the invention of the steam-engine and the electric telegraph, and from the various applications of chemistry to the industrial arts, have all, until the last few years, radiated from England. We have here the secret of a large part of England's riches and England's strength. But it is useless to hope that the mere knowledge of the acquired facts of science will furnish that new weapon which nations are now adding to the sword to enforce their superiority. The mental soil which produces new ideas for a nation's use can only be cultivated by the discipline of scientific investigation. Further, it cannot be doubted that, as modern civilisation is still further developed, the new ideas which a nation produces and throws into a concrete form will be among the most valuable of its exports, because each nation will work up the old ideas for itself.

### AGRICULTURAL EDUCATION

THE application of the law of selection to the production of farm crops and animals offers a certain and wide field for increasing our agricultural wealth. In every department of the farmer's occupation there is great room for improvement if this scientific principle be borne in mind.

It is well known that science has, in our time, thrown extraordinary light on the action of manures. Yet too few of our farmers are guided in their practice by this light. In every district of the United Kingdom farmers apply manures which are either incapable of drawing out the full productive powers of the soil, or comparatively worthless.

Again, it is notorious that the yield of millions of acres of our wet, cold lands could be largely increased by drainage.

There is no branch of agriculture which has progressed so much in modern times as the manufacture of farm implements and machines. Yet, an enlightened and experienced agriculturist who travels through England cannot fail to see an enormous waste of power, arising from the use of unsuitable implements, as well as from ignorance of the elementary principles of mechanical science.

Numerous additional examples could be cited, but it is not necessary. It is enough to state the broad fact that while the foremost of our farmers are the most enlightened in the world, there is a vast number of occupiers of land in Great Britain and Ireland who do not avail themselves of the aids which science is capable of affording them.

To the farmer, as to everybody else, knowledge is power. The increased annual wealth capable of being produced by the application of this power is very considerable. It has been stated by several persons whose opinions on agricultural questions appear to command respect, that the produce of the soil of England could be doubled by improved modes of farming. After having seen from time to time a good deal of English farming, I consider this estimate quite too high; but all thoughtful and experienced persons will concur in the opinion that by the adoption of means which could be called forth, the produce of the soil of Great Britain

would soon be increased to an amount equal to the rental of the entire land of the country; that is to say, *farmers could increase the productive power of the soil to the extent of, say, forty millions sterling a year!* They would reap the first fruits of this harvest. In due time the landlords would come in for their share of it in the shape of increased rents; for, as I have often pointed out, it is a law of agricultural progress that every increase in the productiveness of the land, and every rise in the prices of its products, by increasing the competition for land, tend to raise rents.

How can we increase the productiveness of the land? There are many ways in which progress may be effected; but we must seek the solution of the question mainly in education, using the word in its widest sense.

The wealth of farmers depends on their knowledge, skill, and thrift. Of thrift we shall say nothing in this note. Skill is required by both farmers and labourers. It is a plant of slow growth. The navy acquires it by plodding application. The skill of the high-class agricultural labourer is acquired in the same way. The skill of the high class-farmer, too, is the result of continuous application to business. The skill acquired by one generation is capable of being imparted to, and of being improved upon, by the next. The skill possessed by both agricultural labourers and farmers in England has been thus transmitted, from generation to generation, and improved in its transmission, in accordance with a law of development. It would be unfortunate if any circumstances or set of circumstances should interfere with this development. We cannot now discuss this subject; but it may be remarked that one of the features of the present movement in the agricultural labour market which deserves serious attention is, that skilled hands have left many districts. Several very thoughtful English farmers of my acquaintance already complain of want of skill in the young hands who remain at home. In a recent agricultural tour in England I saw evidence of the same state of things. Unless the movement be arrested, English farming will, in all human probability, undergo a change which may be prejudicial to the agricultural interest. What the tendency of that change would be is foreign to the object of this paper, and accordingly I proceed to make a few remarks on the importance of imparting agricultural knowledge.

It has been already affirmed that general knowledge imparts power to every man. This is true in every state of life. It is true in science; it is equally true in the industrial arts. The proposition is supported by an overwhelming mass of evidence. Royal Commissioners, Special Commissioners, and distinguished independent inquirers are all in unison on the question. All our systems of technical education are based on this one leading idea. The whole programme of the Department of Science and Art is based upon it. In the leading cities and towns the rising generation of the manufacturing classes can acquire scientific knowledge which will be of direct use to them in their several pursuits. In the village school scientific truths are imparted which cannot fail to be of use to the trader and artisan.

How different is the case with the farmer! In his education no systematic effort has been made to instil into his mind those elementary scientific truths on which

enlightened agricultural practices are based. The result is, that he grows up in complete ignorance of the rudiments of agricultural science.

How is this state of things to be remedied? In other words, how is a suitable amount of agricultural science to be imparted to farmers?

In answering this question it is important to distinguish between ordinary working farmers who receive their education in Primary schools, and farmers who are able to pay for a higher education, such as is afforded in boarding schools and seminaries and other institutions of the same grade.

As regards the first of these two classes, I would say that I see no reason why an adequate amount of agricultural instruction could not be imparted in the primary schools. All that is required is a suitable text-book or two, and such a system of inspection as will ensure that the book shall be read, and all difficult passages explained by the teachers. This simple system of agricultural education has been tried in Ireland for many years. It has laboured under many difficulties; but as it has succeeded admirably wherever it has been fairly tried, I can have no hesitation in recommending it for adoption elsewhere. To those who desire to introduce it into England I would say, before you start, see that you are upon the right rails, and that you use the proper instruments. In a movement of this kind all sorts of people will come in with all sorts of advice; the busiest and most active of these may be ignorant of the A B C of science and of enlightened agricultural practice. Keep clear of these people. If not, you will either fail altogether, or effect little good, like many others who, from time to time, have embarked in agricultural education.

I look to the diffusion of sound notions of the elements of agricultural science in the way pointed out, as the best means of removing prejudice, and of increasing the agricultural produce of the land in the hands of small farmers.

It is by no means so easy to devise, for the wealthier farmers, a system of agricultural education which will be successful. The words "agricultural education" have led to much confusion of thought; and confusion of thought on any subject works mischief. Some persons use these words in a way which would imply that the farmer should have a special system of education peculiar to himself, from the moment he enters school till he leaves it for good. Of course this is not the case, and it is certain that in the case of large farmers we must look more to the effects of a good general education than of special instruction. The first truths of physical science, of chemistry, and natural history should enter into the curriculum of every middle-class school and college in the country. This knowledge will be useful to the student, no matter what his future calling may be. As regards the farmer, it may be remarked that, without a knowledge of mechanics he cannot be in a position to buy implements and machines to the best advantage, or to understand how to apply horse-power and other forces in the most judicious manner. Look, for example, at the loss of power daily caused by ignorance of the elementary principles involved in common draught. Look at the loss entailed on farmers in the simple matter of common gates for want of knowledge of the means of resisting strains, and of other principles equally elementary. It has been shown

that in the production of animals and plants very great mistakes are committed for want of knowledge of physiology. This science should, therefore, be taught in all our middle-class colleges and schools attended by farmers. We must not, of course, neglect mathematics, the study of which is the very best training for the mind. If the large farmer be well instructed in all the sciences named, agriculture will keep pace with other pursuits in which scientific knowledge is required. It is in the universal inculcation of this scientific knowledge that I look mainly for progress in the management of large farms. I do not wish to undervalue, and I cannot in these papers overlook, special agencies for imparting agricultural knowledge to this class. I refer to agricultural colleges and agricultural schools. Viewing the subject theoretically, one of these institutions would seem to be the most perfect place at which the future farmer could spend a year after leaving school or college, and before he enters into practical work. He could attend lectures, and he ought, one would suppose, to be able to see theory reduced to practice.

But after having carefully inquired into the working of these institutions at home and in parts of the Continent, I am bound to say that their theoretical value has not been realised in practice. In point of fact, taking them as a whole, their history has been peculiarly unfortunate. I shall refer to this subject more fully hereafter. At present it is enough to state that with few exceptions agricultural schools and colleges have failed; and success in the exceptional cases has turned upon the peculiar fitness of the individuals on whom the management has devolved, and who by force of character have produced striking results. A general failure in working out a comprehensive system cannot be accounted for by the shortcomings of individuals. The failure of an institution here and there, for a time, can often be traced to the inefficiency of the person or persons at the head of them; I have before my mind numerous examples of the kind; but in accordance with a well-known law, suitable men would arise if the demand existed. And why has this law not prevailed in the case of agricultural schools and colleges? The apparent answer is, that farmers everywhere have not sent their sons to these institutions in sufficient numbers. And why? In answering this question it has been invariably stated that farmers as a class are slow to do what is for their good; to me this off-hand sort of reply has always appeared most unsatisfactory. Farmers, like every other class, find out, after a time, what is for their good. Intelligent farmers, like intelligent men in every walk of life, study their own interests. Owing to their isolation, or want of daily intercourse, they do not move in the path of progress as rapidly as the manufacturing classes who live in cities and towns, and who are brought into daily intercourse with one another. But when we find farmers standing aloof from any system established with the intention of serving them, we may take it for granted that there is something inherent in the system which requires to be adjusted or is inimical to success. What is this something in the history of agricultural colleges and schools? For obvious reasons I cannot fully state my experience on this question; but I can say that the answer will be partly found in the peculiar state

of farming as a business. Our scientific knowledge of agriculture, even at the present day, is in a very unsettled state. Theories have risen and fallen in a way which has led rent-paying farmers to regard science with indifference and suspicion. We find evidence of this feeling in our daily intercourse with them. To a large extent they are justified by the vagaries of some of the so-called scientists. I see only one feasible remedy for this, and that is the introduction of the necessary quantity of pure science into the education of the farming classes. This cannot be done in an agricultural college or two. It must be done on a national basis; that is, by establishing science classes in every middle-class college and school throughout the length and breadth of the land. And having done this, a few normal schools of agriculture would soon arise to complete and crown the work. If scientific instruction were placed on a national basis, the normal schools would become filled with the best minds in the country. In the absence of such a system an isolated school or college cannot prevent itself from doing mischief in one direction which has escaped attention; I mean, that if the best men do not enter it, inferior men acquire what I may call an artificial brand which enables them to obtain high positions in connection with agricultural industry—for example, as estate agents and managers—to the exclusion of men of superior natural powers, and to the detriment of the national interests. In other words, the natural law of Selection is subverted.

THOMAS BALDWIN

### THE SHEEP

*The History, Structure, Economy, and Diseases of the Sheep.* By W. C. Spooner, M.R.V.C. Third Edition. (London: Lockwood and Co., 1874.)

THROUGHOUT the whole historic period the sheep has been a source of wealth to man. Mutton has been a staple article of human food, and wool one of the staple materials out of which fabrics have been made for human use. At no period in the history of the United Kingdom has the sheep been so much the object of the farmer's solicitude and care as at the present day. A new edition, purporting to be carefully revised and considerably enlarged, of a work exclusively devoted to the animal, from the pen of Mr. W. C. Spooner, V.S., is, therefore, manifestly entitled to attention. Mr. Spooner has written much. To Blackie's "Cyclopædia of Agriculture" he contributed several valuable papers on veterinary subjects. He has written several other thoughtful essays. He is best known as the editor of an edition of White's "Veterinary Art." The work now before us is the one by which he can best be judged as an author. The title of the volume is pretentious. It would lead the reader to expect an exhaustive treatise; but the most superficial examination corrects this impression.

The volume extends to 322 pages. It is divided into three parts. The first part contains eighty-two pages, and is devoted to the history of the several breeds of sheep. The second part treats of the structure and economy of the sheep, and contains 108 pages; and Part III., occupying the remainder of the text, is devoted to the diseases

of the animal. With one or two exceptions, the matter is arranged under these three heads. The exceptions are, however, unpleasant and unaccountable. This arises, to some extent, from treating of the structure and "economy" under one general heading. In this part of the work the author treats of breeding and feeding, which, according to his notions, are manifestly embraced in the term "economy." In the historical section of the book a good deal of information is given on the origin of new breeds, and it is to the repetition of some of this in the chapters on breeding, and the influence of ram sales in the second part of the book, that exception may justly be taken. Tautology, in this busy age, is a great fault. In the present instance it is the less pardonable, because it is not necessary, or even intended, to call back the mind to principles previously expounded.

In the account given of the several breeds no principle of classification appears to have been kept in view. The practical value of the facts is not, of course, lessened by this circumstance; but it must be admitted that the value of a book is greatly enhanced to the public by a proper classification and arrangement of its matter. Judged by this standard, Mr. Spooner's work is singularly defective. In an essay or chapter on breeding, in Part II., we are treated to a disquisition on the merits of the several kinds of sheep which should have been embodied in the description of the several breeds in Part I. In the section devoted to feeding, there are certain theoretical considerations on the size and structure of the chest and abdomen, which should have appeared in the account of the structure of those regions given in an earlier part of the same section.

It is a most ungracious task to write unfavourably of a work of this kind, but the truth is that this new edition affords evidence of great want of care and thought in its preparation. Words and phrases, and even whole sentences, occur throughout the work which illustrate this statement. Take, for example, the following sentence, which occurs in the section on feeding:—"The superiority of particular improved breeds is now generally acknowledged, and may indeed be considered to be established on certain principles, though in arriving at these principles it must be confessed that we are little indebted to science, but rather to the long and attentive observation and correct reasoning of practical men." Overlooking the defective structure of the whole of this sentence, we would observe that the author's view of the nature of science must be peculiar, to say the least of it. If attentive observation and correct reasoning be not science, we should like to know how science ever arose. It would seem as if speculative reasoning were synonymous with science in the mind of our author.

We take another illustration of the culpable want of care bestowed on the preparation of this work from the section devoted to the treatment of scab. Dipping in arsenic is first of all recommended as one of "the most simple and most effectual." Nothing has been said of the dangers attending the use of this substance, or of the consequences which have often followed its use. Mercurial ointment is also recommended. We are told that "tobacco-water is another remedy which has been found effectual, but the high duty it is subject to limits its application." The author ought to have known that tobacco used for this

certain has been for some time exempt from duty on purpose conditions. An excellent preparation, the *nicotine dip*, is thus manufactured.

We have had in view in the foregoing remarks the utility of this work to practical men who may seek in its pages facts and principles which would be of direct use and benefit to them in their pursuit of agricultural wealth. Possibly the author intends that it should become a text-book for the use of the 760 persons who, according to the last census, are learning farming professionally in England and Wales. Many of these will, it is to be hoped, in due time, become the agricultural luminaries of their country. It is of national importance that their minds should be thoroughly filled with the great truths of scientific agriculture. They can pick up facts readily enough on the several farms on which they reside; but to books they must look mainly for an exposition of scientific principles. To review this book, or any kindred work, in a way which would be of value to the agricultural student, would require more space than is at our disposal. We shall therefore select one subject well adapted to our purpose, and notice the author's treatment of it. That subject is breeding, which to the agricultural student and to the nation at large possesses the deepest possible interest. The section, or essay, on this subject is introduced under a high-sounding title—"The Principles and Practice of Breeding." We expected a masterly exposition of principles and an array of facts to maintain them. We have been disappointed. Some principles enunciated, which are either wholly or partially true, are illustrated by unhappy examples; and statements are made which are either questionable or contradicted by other statements. In common with many authors and breeders, Mr. Spooner is of opinion that in the offspring the characteristics of the male prevail in the majority of cases (p. 145). The discussion of this subtle topic would occupy much space. We cannot enter upon it now. But if the statement were true in the way Mr. Spooner puts it, the majority of lambs would be of the male gender; but it is not always so. In support of the above proposition we are reminded that "the mule partakes more of the nature of its sire, the ass, than of its dam, the mare." This is quite true; but is it not also true that the jennet is more like its dam, the ass, than its sire, the horse? The statements copied from one work into another on the paramount influence of the male are based partly on erroneous views, and partly on inadequate facts. Given a male and female equal in breeding, in age, and vigour of constitution, they will contribute equally to the characters of the offspring. As a rule the male in every class of live stock is better bred than the female; and as a matter of course the offspring partakes more of his characteristics. Mr. Spooner does not appear to have appreciated the hereditary influence. "Some farmers," he says, "are real advocates for a pure breed and a long pedigree, whilst others despise the pedigree and prefer gaining their ends by means of crossing. Each to a certain extent is right, and each wrong." We ask, how can any person be right to any extent, who despises pedigree? Again, we are told, in the same page, that "a long pedigree may be useless." We give Mr. Spooner credit for more intelligence than to believe he entertains the opinion which those words convey. Indeed, we go so far as to ex-

press our belief that, owing to the peculiar style in which he writes, his words do not always convey his real views. We find additional evidence of this in his remarks on breeding in-and-in. Any person conversant with the first principles of breeding knows that breeding in-and-in intensifies the hereditary influence. Two rams, for example, equal in size, age, shape, vigour, and quality, but differing in this—that one is closely bred, while the other is not, will leave their marks on the offspring in very different degrees. The one which is closely bred will, as every breeder of experience and intelligence knows, perpetuate his own points with much greater certainty than the other. According to the language of Mr. Spooner, we should look chiefly to the "resemblance" of the parents. "The stronger resemblance," he says, "there is between the qualities of both parents, if they are good, the more likely is it that the offspring will be perfect." While it is quite true that the nearer the sire and dam approach to each other in shape and quality the better, we are not to recognise this as the embodiment of any fundamental principle of breeding. One of the most difficult things the breeder of improved stock has to effect is to produce uniformity of type or resemblance. The question is, How is it to be done? The answer is this: Skill must be exercised in pairing animals until the desired qualities are produced; and those qualities once obtained, are fixed by close breeding. It is thus that the qualities of shorthorn cattle and Leicester sheep were permanently established. And it is thus, and thus only, that any breeder of our time, or of future time, can succeed in establishing an improved variety of our domestic animals.

In this section of his book, as well as in other parts of it, Mr. Spooner gives a large number of useful and instructive facts on the subject of crossing. We feel very great pleasure in adding that his remarks on this important subject will be worth many times the cost of the work to thousands of sheep-farmers in Great Britain.

#### CLOWES'S PRACTICAL CHEMISTRY

*An Elementary Treatise on Practical Chemistry and Qualitative Inorganic Analysis, specially adapted for use in the Laboratories of Schools and Colleges, and by Beginners.* By Frank Clowes, B.Sc. Lond., Science Master at Queenwood College. (London: J. and A. Churchill, 1874.)

IF the rate of progress of a science is to be measured by the number of text-books produced annually, Chemistry must assuredly advance with greater strides than any of its sister sciences. Whether this is actually the case we leave to our readers to judge, contenting ourselves here with pointing out the fact that while English Physics is represented by a few manuals, of which a considerable proportion are translations from foreign works, the market is, so to speak, glutted with an ever-increasing stock of chemical text-books.

The volume now before us is the production of a practised teacher of the science, and will doubtless be found of service outside the author's own classes. The work is divided into seven sections and an appendix. In the first section the student is introduced to experiments illustrating the methods of preparation and properties of

the common gases, such as oxygen, hydrogen, carbon dioxide, nitric oxide, ammonia, carbon monoxide, chlorine, and hydrochloric acid. After the preparation of these gases the student is made acquainted with the process of distillation as applied to water, and to the preparation of nitric acid. The entire absence of theory from this section is perhaps to be regretted. Although a student may have previously read the reactions that occur in the preparation of the various gases, there is no more favourable opportunity for impressing these upon the mind than at the time of performing the experiment for himself. If beginners were always to ask themselves, What *chemical* change is going to occur in this tube or flask? and then write down the equation, the knowledge gained would not be of that purely mechanical nature which the boring of corks and bending of glass tubes alone tend to engender.

Section II. treats of the preparation and use of the apparatus required for analysis. Bunsen's burner, the spirit lamp, blowpipe, bending and cutting of glass tubing, cork-boring, and other practical minutiae, are here described, and some valuable hints given on the use of the various pieces of apparatus employed by the student of analysis.

The details of glass-working seem to us somewhat misplaced here. Tubing must be bent, and corks bored and fitted into flasks, tubes, &c., in the course of fitting up the apparatus for the preparation of gases; so that it would be more logical if this section were made to precede Section I. We miss from this section, also, any reference to the excellent blowpipes made on Herapath's principle, now so generally employed in our laboratories. Students who have once used these blowpipes soon abandon the old mouth blowpipe figured in the present work.

The various operations connected with analysis are described and experimentally illustrated in Section III. Here the student is made acquainted with the processes of solution, crystallisation, filtration, evaporation, precipitation, ignition, &c., and the way is thus prepared for the next section, wherein are given the analytical reactions of the more commonly occurring metals. The author adopts the usual analytical classification; this section, indeed, offers but little scope for originality, and we find the same tests and reactions which are to be found in the works of Fresenius and Rose, and the many volumes of their imitators. The modicum of theory relating to the use of symbols and the expression of reactions as equations, which we should have preferred to see in an earlier portion of the book, finds place at the beginning of the present section. We are glad to see equations given for most of the reactions of the metals; too often the words "white pp." or "black pp." go down into the student's note-book without any idea of what chemical change has occurred having entered into his mind. After the reactions of the metals of each group, tables are given showing the characteristic differences between the members of that group and the methods to be pursued in the cases of mixtures. This plan of tabulating the differences between the various metals of a group is a special feature of the present work; in this country the idea seems to have been first introduced into Galloway's "Manual of Qualitative Analysis," and its adoption by Mr. Clowes is to be highly commended.

When a student is made to go through a long series of reactions with closely allied metals, he is apt to overlook the points in which they differ unless these are specially pointed out to him. It is as though a zoologist were to give lengthy descriptions of two closely allied species of a genus without any reference to their differential characters. The reactions of the acids, inorganic and organic, follow those of the metals.

Passing on to Section V., we find the ordinary course of analysis pursued in [the case of a simple salt containing one base and one acid, the tables being modified to meet the cases of solids and liquids, acid or alkaline.

In the following section, containing the complete course of analytical tables for complex mixtures, we recognise the well-known tables compiled, we believe, by Dr. Hofmann for the Royal College of Chemistry. The phosphate table devised by Mr. Valentin has been introduced with the author's permission. The present work offers, therefore, as good an analytical course as is to be found in any of our text-books, the type in which the tables are printed is decidedly small, but the plan of printing them *across* instead of *along* the page, offers, as the author justly claims, a distinct advantage.

Section VII. is devoted to a description of apparatus and reagents used in the analytical course. The methods given for constructing pieces of apparatus for general use, and the preparation of special reagents such as hydrofluosilicic acid, will be found valuable adjuncts to the book. The appendix contains a list of elements with their symbols and atomic weights, formulæ for the conversion of thermometric scales, and tables of weights and measures.

It will perhaps be better not to inquire into the *raison d'être* of the work an outline of which we have now laid before our readers. It may be asked why the student should not be made acquainted with the method of preparation and properties of nitrogen, nitrous oxide, phosphoretted hydrogen, and cyanogen; these gases surely are of sufficient chemical importance to justify a knowledge of their properties, and their preparation cannot but furnish good exercise for the manipulatory skill of a student. The list of corrigenda is certainly alarming, and we hope the author will have the opportunity of correcting these in a later edition.

The defects we have had occasion to point out in the course of this notice are not, it must be admitted, of a very grave character. We do not scruple to say that the author has performed his task on the whole well, and we should have no hesitation in putting the book into the hands of the chemical student.

The present volume may, in fact, be taken as a fair average specimen of the systems of teaching practical chemistry followed in this country, and as such we shall venture a few remarks upon it in concluding. In the first place, we should like to see a little more *science* introduced into our courses of analysis—something of the nature of a chemical key to the analytical tables is in our opinion a desideratum. At present the student generally follows blindly the instructions given in the tables; he dissolves, precipitates, or filters without any regard to the chemical reactions occurring at the various stages. It is similar to the old system of learning off a problem of Euclid by heart, without entering into the reasoning—change the

order of the letters, and confusion is the result. Then, again, we venture to think that a little more of what we may call manufacturing chemistry might be with advantage introduced into our laboratories. After preparing the gases, the student goes on to study the analytical reactions of the metals, where there is very little scope for manipulation. Between these stages, or simultaneously with the latter, the preparation on a large scale of some of the reagents used in analysis, or of some compounds demanding skill and caution, such, for example, as the chlorides of phosphorus, would give a more extended knowledge of practical details, and at the same time furnish the student with a certain amount of technical instruction equally valuable to him as a scientific man or as a manufacturer.

### LETTERS TO THE EDITOR

[The Editor does not hold himself responsible for opinions expressed by his correspondents. Neither can he undertake to return, or to correspond with the writers of, rejected manuscripts. No notice is taken of anonymous communications.]

#### The Royal Agricultural Society and the Potato Disease

My attention has been drawn to a letter in NATURE, vol. xi. p. 67, signed "W. T. Thiselton Dyer," and headed "Royal Agricultural Society and the Potato Disease." It appears that Prof. Dyer has founded the statements and criticisms in that letter upon a paragraph which appeared in the preceding number of NATURE. Had he taken the trouble to read the official reports that have been published by the Society in the agricultural newspapers, the criticisms he might then have made would probably have had some value; and I must express my surprise that a man of scientific pursuits should have omitted to take that most necessary and most elementary course which I may term the verification of fundamental facts. This is the more remarkable as he criticises the Society's want of "methodical scientific method of investigation."

Prof. Dyer asks, "Is it not surprising that the Royal Agricultural Society should think the offer of a 100*l.* prize for an essay in any way an adequate method of dealing with the subject?" Now, what does Prof. Dyer mean by this question? He seems to imply that the Royal Agricultural Society offered such a prize, and that therefore they thought it an adequate method of dealing with the subject. But the Society did not offer such a prize, and have not considered whether such a method would or would not be adequate to deal with the subject.

The truth is, that Lord Cathcart offered such a prize two years ago, and asked the Council of the Society to nominate the judges and otherwise to take charge of the competition. This they did, and for this alone are they responsible.

Prof. Dyer proceeds: "The Society then determined to offer prizes for disease-proof potatoes." To this I must beg leave to reply that the Society did not offer prizes for "disease-proof potatoes," but for potatoes which should resist disease for three years in succession in twenty different districts of the United Kingdom. If the somewhat lengthy statement of the terms on which the prize was offered has been colloquially abbreviated into "disease-proof potatoes," that does not justify a scientific man in basing an argument upon it, especially in the columns of a scientific journal.

Prof. Dyer continues: "The utter futility of this proceeding was clearly obvious to anyone in the least acquainted with the subject." Here again I must join issue with the Professor. This prize was offered because certain essayists asserted, and seedsmen advertised, that they possessed varieties of potatoes which would resist disease. To put these statements to the test was in conformity with the Society's ordinary practice, which is to endeavour to make its members acquainted with the actual agricultural value of various articles, whether they be seed-potatoes, manures, implements, or other commodities. As the result has been to show that none of the potatoes experimented upon can resist disease for even one year in our twenty stations, the members of the Society now know what value to attach to the assertions of their proprietors, and the result is therefore not utterly futile.

These experiments have also been utilised to ascertain the influence of soil, climate, and modes of management on the crop

itself, and on the potato disease; and the results of this inquiry are now being worked out.

Prof. Dyer goes on to say: "Now, it seems to me that this spasmodic and ill-considered way of dealing with a serious subject contrasts, to an extent that it is impossible quite to regard with satisfaction, with the course that would be adopted in such a matter in other countries. It shows, at any rate, how little the methodical scientific method of investigation is understood by the majority of well-informed English people." I am content to ask Prof. Dyer to point out what is "spasmodic" and what is "ill-considered" in the action of the Society, and how does he justify his assertion about "the methodical scientific method of investigation?"

It must be remembered that the Royal Agricultural Society was not established for the advancement of science, and certainly not for the advancement of botany; but it was established for the promotion of agriculture, especially by the encouragement of the application of the discovered truths of science to the practice of agriculture, as is shown by its motto, "Practice with Science."

The Royal Agricultural Society does, however, enlist the services of scientific men upon its regular staff, and in this and other ways seeks to direct their attention to agricultural problems upon which the light of science is still wanting. As Prof. Dyer has contrasted the Society's "spasmodic and ill-considered way" with "the course that would be adopted in such a matter in other countries," I hope that he will inform me of the course that Agricultural Societies in other countries have adopted in reference to the potato disease and other such matters, without receiving assistance from the Government of the country.

I now come to what Prof. Dyer calls his "second point." He states that the Society, "anxious not to be entirely foiled, offered a sum of money to a well-known investigator of the life-history of fungi, Prof. De Bary, of Strasburg, to induce him to study the potato disease. Considering that De Bary had already written an admirable memoir on the *Peronospora*, there was a certain simplicity in supposing that the gift of a sum of money would elicit some additional information which his zeal as a scientific investigator had failed to do."

So far as I understand the meaning of the phrase "anxious not to be entirely foiled," it implies some previous disappointment. Now, so far is this from having been the fact, that the first step taken by the Council of the Society was to direct me to write to Prof. De Bary and urge him to continue his researches into the life-history of *Peronospora infestans*, in view of the vast importance of the subject in its agricultural bearings. Therefore I cannot see how the term "anxious not to be entirely foiled" can be made applicable to it.

The Society at the same time volunteered to place a sum of money at his disposal towards defraying the expenses which he might find it necessary to incur, but I hope that my communication to Prof. De Bary was not conceived in the offensive spirit which Prof. Dyer seems to suggest. The principle involved has been adopted by the British Association as one of the best means of advancing science, and I consider it a very different matter from that "certain simplicity" which Prof. Dyer derides.

This was not only the first, but it was the only step then taken by the Society in reference to the scientific questions bearing upon the potato disease; and its results up to this time are in no respect indicated by the grotesque statements which Prof. Dyer quotes.

H. M. JENKINS,  
Secretary of the Royal Agricultural  
Society of England

Nov. 29

#### Anabas Scandens

In a short notice of the contents of the August number of the *Bulletin de la Société d'Acclimatation de Paris*, in NATURE, vol. xi. p. 93, reference is made to M. Cabonnier's announcement of "the arrival from India of several specimens of three varieties of fish never hitherto brought to Europe—the *Anabas scandens* or Climbing Perch," &c. With respect to the *Anabas scandens*, I wish to remark that in April 1872 I sent from Calcutta to the Gardens of the Royal Zoological Society of Ireland two specimens of this fish. Both specimens arrived safely and were exhibited in a tank in the Gardens; one died soon after arrival, the other lived for several months, succumbing at length to the cold of the following winter.\*

Royal Victoria Hospital, Netley, Dec. 5 G. E. DOBSON

\* See Forty-first Annual Report of the Royal Zool. Soc. of Ireland: also P. Z. S. Lond. 1874, p. 319.

FERTILISATION OF FLOWERS BY INSECTS \*  
VIII.

*Alpine Species adapted to Cross-fertilisation by Butterflies, while the most nearly allied species which inhabit the plain or lower mountain region are adapted to Cross-fertilisation by Bees.*

IN the last article I attempted to show that in the Alpine region Lepidoptera are far more frequent visitors of flowers than in the plain and lower mountain region, while the frequency of Apidæ, not only absolutely but to a still greater extent relatively, is greatly diminished towards the snow-line. If this be so, whatever may be the cause of the fact, it is hardly to be supposed that the

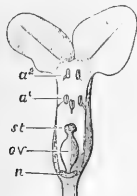

FIG. 41.—*Daphne Mezereum*, L., dissected longitudinally.

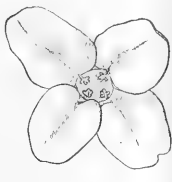

FIG. 42.—The same flower viewed from above.

(Both figures  $3\frac{1}{2}$  times natural size.)

different proportion of visitors of such different structure as butterflies and bees should not have in any way influenced the adaptations of the flowers; and indeed, even during my short stay in the Alps, I succeeded in finding some species of flowers adapted to cross-fertilisation by butterflies, their most nearly allied species which inhabit the plain or lower mountain region being adapted to cross-fertilisation by bees.

1. *Daphne Mezereum* and *striata*.—In both species (Figs. 41-44) the nectar is secreted in an annular swelling (*n*) at the base of the ovary (*ov*), and is contained in the lowest part of the tubular corolla, which includes (1) the ovary (*ov*), terminated by a short-styled, knobbed stigma

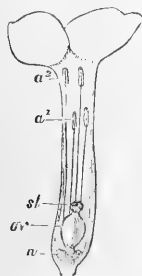

FIG. 43.—*Daphne striata*, Tr., dissected longitudinally.



FIG. 44.—The same flower viewed from above.

(Both figures  $3\frac{1}{2}$  times natural size.)

(*st*); (2) four lower anthers inserted above the centre of the corolla-tube (*a*<sup>1</sup>); and (3) four higher anthers inserted near its mouth (*a*<sup>2</sup>). In both species, therefore, the proboscis of a visiting insect, when in search of the honey, grazes at first the higher, then the lower anthers, and at last the stigma; but the pollen-grains, being only slightly sticky, scarcely adhere to the proboscis, and, at the most, some few grains will be brought by it to the stigma of the same flower. Only when retreating out of the flower will the proboscis, wetted with honey, be dusted by any con-

\* Continued from p. 33.

siderable number of pollen-grains, which will partly be deposited on the stigma of the next visited flower. Thus cross-fertilisation is secured in case suitable insects visit the flowers, whereas when visits of suitable insects are wanting, pollen may easily fall down in both species from the anthers upon the stigma of the same flower, and effect self-fertilisation.

Agreeing thus far, the flowers of the two species differ remarkably in the length and width of the corolla and in the insects which they attract. The corolla-tube of *Daphne Mezereum* being 6 mm. long and 2 mm. wide, its honey is accessible to a great number of bees, among them to all humble-bees, and to some flies (*Eristalis*, *Rhingia*), which will be attracted by the bright red colour, and when seeking for honey and flying from flower to flower will regularly effect cross-fertilisation. The honey is also accessible to butterflies, but in consequence of the width of



FIG. 45.



FIG. 46.



FIG. 47.



FIG. 48.

FIG. 45.—*Primula villosa*, Facq. Long-styled flower, natural size. FIG. 46.—Lower part of the same flower, longitudinally dissected;  $3\frac{1}{2}$  times natural size. FIG. 47.—Short-styled flower, natural size. FIG. 48.—Lower part of same flower, longitudinally dissected;  $3\frac{1}{2}$  times natural size. *n*, nectary; *ov*, ovary; *st*, stigma; *a*, anthers.

the corolla-tube the slender proboscis of these insects will often be entered and retracted without touching anthers and stigma. *Daphne striata*, on the contrary, with corolla-tubes of 10-11 mm. long, the entrance of which is only 1 mm. wide, is hardly accessible to any insects except Lepidoptera; and the pale rose or whitish colour of its flowers, crowded together in tens or twenties into umbels, and the entire absence (or nearly so) of scent in the day-time, while they emit a remarkably sweet scent during the evening twilight, prove them to be adapted to Spingidae and moths,\* which, when visiting the flowers, in consequence of the narrowness of the corolla-tube, cannot avoid grazing the anthers and stigma and regularly effecting cross-fertilisation.



FIG. 49.



FIG. 50.

FIG. 49.—*Primula officinalis*, Facq. Short-styled flower, natural size. FIG. 50.—The same: Short-styled flower, longitudinally dissected. (Copied from Hildebrand, "Geschlechtervertheilung," p. 31.)

2. *Primula officinalis* and *villosa* (Figs. 45-50) are connected with one another by a relation analogous to that between *Daphne Mezereum* and *striata*. Both offer the remarkable contrivances for cross-fertilisation which Mr. Darwin has discussed in so masterly a manner in his paper on *Primula*,† that is to say, both possess two forms of flowers, a long-styled (Figs. 46, 49) and a short-styled (Figs. 48, 50), growing on different stems and existing in nature in about equal number. As is evident from the

\* I have not yet succeeded in actually observing the fertilisation of either of these two species of *Daphne*.

† "On the Two Forms or Dimorphic Condition in the Species of *Primula* and their remarkable Sexual Relations," Proc. Linn. Soc. vi. (1852). Bot. PP. 77-99.



comparison of Fig. 46 with 48 and of 49 with 50, the anthers of the short-styled form are placed at the same height in the corolla-tube as the stigma of the long-styled, and, conversely, the stigma of the short-styled at the same height as the anthers of the long-styled form. Hence the same part of the body (head or proboscis) of any visiting insect which has touched the anthers of the short-styled form touches the stigma of the long-styled form, and conversely, so that by the regular visits of insects, flowers of the long-styled form are fertilised by pollen of short-styled flowers, and vice versa. Thus in *Primula officinalis* and *villosa*, as in all dimorphic species, intercrossing of

different plants takes place naturally; and, as Mr. Darwin has proved by experiment, is the only manner of fertilisation that is followed by perfect fertility. But whilst identical in the arrangement of all the parts of the flower and in their remarkable sexual relations, our two species of *Primula* differ in the wideness of their corolla-tube to such an extent that the wide mouth of the flower of *P. officinalis* is capable of including the whole head of a humble-bee; whereas the narrow corolla-tube of *P. villosa* is not capable of including anything larger than the proboscis of a humble-bee (compare the corolla-tube in Figs. 46 and 48, which, although three-and-a-half times magnified

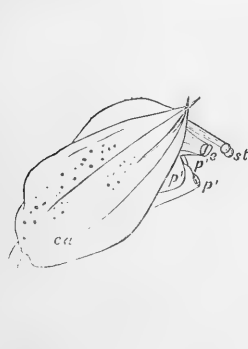

FIG. 51.



FIG. 52.

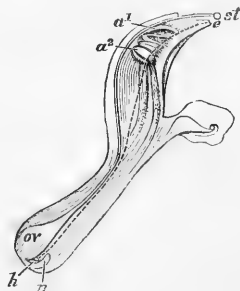

FIG. 53.

appears hardly as wide as the mouth of the flower in Figs. 49 and 50, which is the natural size). In consequence of this narrowness, the flowers of *P. villosa* are not only unavoidably cross-fertilised when visited by butterflies, but they are also far more attractive to butterflies, because their honey, inaccessible to humble-bees, is reserved for them alone; indeed, except some little Coleoptera, I observed only Lepidoptera visit the flowers of this Alpine species of *Primula*,\* whereas the flowers of *Pri-*

*mula officinalis* are adapted by their dimensions to the visits of humble-bees, and are actually visited by them.\*

A third example of the same relation between Alpine species and those from the lowlands is presented by *Rhinanthus alpinus* (Figs. 51-56), as compared with *R. crista galli* (Fig. 57). *R. crista galli*, which grows in the plain and lower mountain region, presents two varieties or sub-species; *a, major*, and *β, minor*, with different forms of flowers; *a, major* with more conspicuous

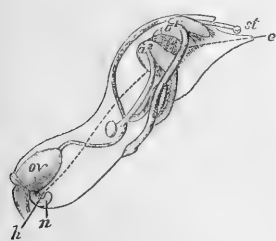

FIG. 54.



FIG. 55.



FIG. 56.



FIG. 57.

FIGS. 51-56.—*Rhinanthus alpinus*.—FIG. 51.—Lateral view of a young flower when still almost entirely enclosed in the calyx (*ca*). FIG. 52.—Corolla of another young flower, somewhat more full-grown, viewed from beneath. FIG. 53.—The same corolla, longitudinally dissected. FIG. 54.—Corolla of an older flower viewed laterally. FIG. 55.—Front view of the same flower. FIG. 56.—Corolla of the same flower, longitudinally dissected, but all four anthers reserved. FIG. 57.—*Rhinanthus crista galli, β minor*.  
All figures are 31 times natural size. In all figures:—*ca*, calyx; *p, p, p*, upper petals, forming together the upper lip; *p', p', p'*, under petals, forming the underlip; *a', a'*, longer stamens; *a'', a''*, shorter stamens; *n*, nectary; *h*, honey; *ov*, ovary; *st*, stigma. The dotted line on Figs. 53 and 56 signifies the supposed path of the proboscis of butterflies.

ones which never fertilise themselves, *minor* with less conspicuous ones regularly fertilising themselves, in case the visits of insects are wanting (NATURE, vol. viii.,

\* Visitors of *Primula villosa*.—(A.) Coleoptera: *Anthobium excavatum* Er., frequently, crawling without difficulty into the flowers and out of them. (B.) Lepidoptera: *Pieris callidice* Esp., *Zygona exultans* Rain, both sucking perseveringly and flying from flower to flower.—Piz Umbrail, July 16, 1874.

pp. 433-435). Both are adapted to cross-fertilisation by humble-bees, which, inserting their proboscis into the comparatively wide entrance of the upper lip (*e*, Fig. 57)

\* Visitors of *Primula officinalis*.—(A.) Coleoptera: *Meligethes*. (B.) Diptera: *Bombylus discolor* Mgn., sucking. (C.) Hymenoptera, Apidae: *Anthophora philipes* F., ♂ ♂, *Bombus muscorum* L., ♀♀, both frequently sucking; *Andrena Gonyana* K., ♀, *Halictus cyathophilus* F., ♀ and *Halictus alpestris* F., ♀, collecting pollen of short-styled flowers.—Thuringia, April 16, 1873.

and pressing it between the upper parts of the filaments, cannot fail to pull asunder the anthers, and thus to cause many loose pollen-grains to fall down upon the proboscis, which are deposited on the stigma of the next flower following.\* Thus, in both, cross-fertilisation is secured in case humble-bees visit the flowers, whereas butterflies may easily thrust their slender proboscis down to the honey without even touching the anthers, consequently without any benefit to the plant. Suppose, therefore, that *R. crista galli* (*a*) *major* were growing in the Alpine region, and visited frequently by butterflies, but never or only very exceptionally by humble-bees, all or nearly all the individuals would of necessity perish without leaving posterity, unless any modification of the flowers adapted to cross-fertilisation by butterflies appeared. *R. alpinus* may perhaps be considered as having originated in such a way; for the arrangement and mutual situation of all the parts of its flower is just the same as in *R. major*, with only this modification, that the entrance between the margins of the upper lip (*c*, Fig. 57), through which in both forms of *R. crista galli* butterflies as well as humble-bees thrust their proboscis, in *R. alpinus* is completely closed (*pp*, Figs. 54, 55), only a minute opening (*e*, Figs. 51-56) between two lateral flaps being visible at the tip of the beaked prolongation of the upper lip. No other insects except butterflies would be able to insert their proboscis through this narrow entrance into the flower; and butterflies, when doing so, could not fail to thrust their proboscis between the left and right anthers (as explained by the dotted line in Figs. 53 and 56), and to dust it with pollen-grains, which would partly be deposited on the stigma of the young flower next visited; for in young flowers (as shown in Figs. 51 and 53) the style overtops the tip of the beaked prolongation, and the stigma is placed before the minute opening, just in the way of any entering proboscis, whereas in older flowers the stigma is retracted behind the opening by an incurving of the style (as shown in Fig. 56).

HERMANN MÜLLER

## THE TRANSIT OF VENUS

THE long-anticipated Transit of Venus took place yesterday morning; and already has the first instalment of news from distant observers arrived. The Astronomer Royal has been good enough to inform us that Col. Tennant's observations at Roorkee, India, have been quite successful; 100 photographs have been taken. He also telegraphs, at the moment of going to press, the gratifying intelligence that the micrometric observations near Cairo and Suez, and the photographic observations at Thebes have entirely succeeded.

At the last meeting of the Astronomical Society the Astronomer Royal gave an account of the final arrangements of the English parties, which do not vary much from those we stated some time ago, *ŷ* Messrs. Green have arranged for one of their outgoing ships to pass near Kerguelen's Land, with a view of picking up intelligence and telegraphing it from Melbourne.

The southern stations occupied by the American, French, and German parties leave no doubt that the Halleyan method will be extensively employed.

The final arrangements of the French parties have been telegraphed to yesterday's *Times* as follows:—

"France has six stations—three in the Northern Hemisphere, at Peking, Nagasaki, and Saigon; and three in the Southern Hemisphere, at Noumea, Campbell Island, and St. Paul's Island. Three of these, Nagasaki, Cochinchina, and Noumea, present comparatively no difficulties as regards the voyage and installation. The Nagasaki Commission is headed by M. Janssen, member of the Institute and the Board of Longitude, who has taken part in several scientific voyages resulting in important discoveries. He is assisted by M. Tisserand, superintendent of the Toulouse Observatory, and M. Picard,

a naval lieutenant, who will employ the photographic apparatus of MM. Fizeau and Cornu, while a professional photographer will use an apparatus invented by M. Janssen. In Cochinchina there will be only one observer, M. Héraud, a hydrographic engineer. It was at first decided, as a measure of economy, to dispense with the observations in Cochinchina, but it was ultimately resolved to profit by M. Héraud's presence in the colony. He will probably be stationed in Tonquin, of which he is preparing a map. M. André, of the Observatory, and M. Angot, of the College of France, have proceeded to Noumea with an equatorial and photographic lens. The observers at Peking, St. Paul, and Campbell Islands have had to encounter greater difficulties. It is not very easy to reach Peking with cumbersome luggage. The Commission has had to reach Tien-tsin by Suez and Shanghai, and thence proceed in junks by the canals. It is headed by M. Fifiuria, a naval lieutenant celebrated for his astronomical labours, and comprises two other naval officers, MM. Blarez and Lapiet. Their return may be toilsome, as the winter will obstruct the transport of their instruments. At St. Paul and Campbell Islands the observers have had to found a temporary colony in uninhabited islands, without any resources. St. Paul, situated nearly in the centre of the line from the Cape to Australia, is the crater of a volcano which is becoming extinct. There are steep cliffs on all sides, but towards the west the cone sinks, and the interior of the crater forms a creek where vessels can penetrate. No pure water is to be found. The encampment has been established as near as possible to the sea, the salt water having to be distilled for drinking purposes. The St. Paul Commission is composed of M. Mouchez, captain and member of the Board of Longitude, the author of works on the coast of Brazil and Algeria; M. Turquet, naval lieutenant, long accustomed to astronomical observations, as his coadjutor; M. Cazin, an eminent Professor at the Lycéeum of the Rue du Havre, who is entrusted with the photography; and a navy surgeon, M. Rochefort, who will devote himself to the natural history of the island. The Commission is accompanied by twelve naval officers and sailors. Campbell Island, the most distant station, is about 200 leagues south of New Zealand. It is likewise uninhabited, its climate seems disagreeable, and, unfortunately, the sky, as at St. Paul, is rarely free from clouds. It possesses, however, good water and a good port. The observers are MM. Bouquet and Hatt, both eminent hydrographic engineers; M. Courrejolles, naval lieutenant; and M. Filhol, the delegate of the Museum and the surgeon of the expedition. There are also twelve sailors. Everything necessary for the subsistence of sixteen men during three months has had to be transported to these two last stations, three months being necessary to determine the exact latitude and longitude of the observatories."

## ON THE NORTHERN RANGE OF THE FALLOW DEER IN EUROPE

IN the interesting essay by Dr. Jettelce, translated by Dr. Sclater, in *NATURE*, vol. xi. p. 71, many cases of the reputed discovery of the remains of the Fallow Deer are collected together to prove that the animal is indigenous in Northern Europe, and not imported from the south, as heretofore has been supposed by many able naturalists, such as Blasius, Steenstrup, Rüttimeyer, the late Prof. Ed. Lartet, and others. These cases are accepted by Dr. Sclater without criticism, and are deemed by him to place the importation theory, as it may be termed, in the category of "ancient fables." The question, however, seems to me, after many years' study of the fossil and recent *Cervidæ* of this country and of France, a very difficult one, not to be decided off-hand, and certainly not without a strict

\* H. Müller, "Befruchtung der Blumen durch Insecten," p. 294, *ŷ* *et seq.*

analysis of the value of evidence such as that recorded by Dr. Jeitteles, whose method and facts appear to be equally in error.

The identification of fragments of antlers is one of the most difficult tasks which a naturalist can take in hand, and where there are several species of deer associated together in the same deposit, it is sometimes impossible to assign a given fragment to its rightful owner. For example, in the forest beds of Norfolk and Suffolk, and in the Pleiocenes of the Continent, there is a vast number of antlers which are ownerless and which have completely baffled Prof. Gaudry, myself, and others for many years. It is, of course, easy for anyone to classify the flat antler as belonging to one species and the round to another; but the value of the determination depends upon the number of species living at the same time in the same place, possessed respectively of round and flattened antlers. In the Pleistocene and Prehistoric ages, there were four animals which had portions of their antlers flattened—the Reindeer, Irish Elk, True Elk, and Stag—to which, according to Dr. Jeitteles, must be added the Fallow Deer. In this particular case it is not only assumed that the flat antler fragments belong to the last of these animals, but even the uncertain testimony of various authors, who had not critically examined the remains, which they record, in relation to the other species, is taken to prove the range of the Fallow Deer as far north as Denmark. The mere printed reference to the Fallow Deer is accepted as evidence, without, save in two cases, being verified by personal examination. The results of such a method of inquiry seem to me to demand most careful criticism.

The alleged cases of the discovery of Fallow Deer in Central and Northern Europe are as follows. In Switzerland, it is stated to have been identified by Dr. Rüttimeyer among the animals which had been used for food by the dwellers in the Lake villages; "although," he writes, "incontrovertible evidence of the spontaneous existence of this deer north of the Alps remains still to be obtained" (quoted by Dr. Jeitteles in NATURE, vol. xi, p. 72.) In a list of the Swiss mammalia which Dr. Rüttimeyer was kind enough to prepare for me in 1873, the animal is altogether omitted from the Pleistocene and Prehistoric Fauna. Thus, in the opinion of this high authority, it was not living in Switzerland in those early days. The animal is stated also (on the authority of Jäger in 1850) to have been found abundantly in "the caverns and turbaries as well as in the diluvial freshwater chalk of Wurtemberg." To this I would oppose the opinion of my friend Prof. Oscar Fraas, of Stuttgart, from whose list of animals (sent to me in 1872) the Fallow Deer is conspicuous by its absence. The Reindeer is abundant in the caves of that region, and to it the flattened fragments of antlers may probably be referred.

To pass over the reputed discovery of the animal "in an old place of sacrifice" near Schlieben, in 1828, in which the discoverer himself remarks that "the subject requires further investigation," there only remain three other sets of fragments to be examined in Germany. First, those at Olmütz, which Dr. Rüttimeyer considered to belong possibly to the Stag; secondly, an indistinct figure in the "Ossemens Fossiles," of an antler attached to a skull found at Stuttgart, which seems to me to belong to the Reindeer; and lastly, a fragment of antler from Buchberg, which, taken along with the find at Olmütz, is the second of the two cases identified by Dr. Jeitteles. It is a museum specimen, which may very probably be liable to the same doubts as those which are entertained by Dr. Rüttimeyer regarding the fragments from Olmütz. The teeth and bones quoted from Hamburgh are as likely to belong to the Stag as to the Fallow Deer.

The alleged instances of the discovery of the animal in this country and in France are equally unsatisfactory.

The flattened antlers alluded to by Buckland and Owen belong either to the Stag or the Reindeer. Among the many thousands of bones and teeth which I have examined from the ossiferous caves of various ages, from refuse-heaps, and tumuli, I have never seen any fragment which could be attributed to Fallow Deer, except in refuse-heaps not older than the Roman occupation. Nor is it found in Ireland till the Middle Ages. The late lamented Prof. Ed. Lartet, whom I always consulted on difficult questions such as these, believed that the animal was not living in Central and Northern France in the Pleistocene or Prehistoric ages, but that it was imported probably by the Romans.

The only evidence against this view is that afforded by an antler dug up in Paris and brought to Prof. Gervais along with stone celts by some workmen. It seemed to me when I saw it in 1873, in the Jardin des Plantes, not altogether conclusive, because of the absence of proof that all the remains were obtained from the same undisturbed stratum. I should expect to find such antlers in the refuse-heaps of Roman Paris, as in Roman London, and I should not be at all surprised if the remains of widely different ages were mingled together by the workmen, even if they were found in the same excavation. As examples of the necessity of guarding against this source of error, I may quote a recent lower jaw of Kangaroo Rat in the collection of my late friend Mr. Wickham Flower, which was stated to have been dug out of the brick-earth near Sittingbourne, along with the mammoth and other Pleistocene creatures; the bones of an ostrich brought to Prof. Busk, along with mammoth and hippopotamus from the gravels of Acton Green; and lastly, the skeleton of Fallow Deer found in a bog not far from the River Boyne above Leinster Bridge (Co. Kildare), along with a skull of Brown Bear (Scott, *Journ. Geol. Soc. Dublin*, vol. x, p. 151). This last case would have been taken as decisive that the animal lived in Ireland in prehistoric times as a contemporary of the Brown Bear, had not a silver collar round its neck proved that it had belonged to "a member of Lord Rosse's family."

From premises so unsatisfactory as those which have been examined, it seems to me very hazardous to conclude with Drs. Jeitteles and Slater that the Fallow Deer inhabited Northern and Central Europe in the Pleistocene and Prehistoric ages. The point, to say the very least, is non-proven. On the other hand, the non-discovery of certain relics of the animal by the many able naturalists who have examined vast quantities of fossil remains from those regions, implies, to my mind, the probability that the animal was not then in those parts of Europe. The value of negative evidence depends upon the number of observations, which in this case is enormous. To speak personally, I am in the position of a man waiting for satisfactory proof, holding that up to the present time the common Fallow Deer "has never been found to occur in the fossil state in Northern and Central Europe"—a position which I see no reason to change from the arguments brought forward in NATURE. The animal *ought* to be found fossil in those regions; and it is not for want of looking that it has not yet been found.

For the sake of clearness, I have reserved the reference to other forms of deer, in the essay, for separate discussion. The *Cervus polignacus* of Pomel, from Auvergne, is an obscure form without definition, about which I will not venture to say anything. The *Cervus somoniensis* of Cuvier, which I have carefully studied in Paris along with Prof. Gervais, is identical with the form which I have described from Clacton, Essex (*Quart. Geol. Journ.*, 1868, p. 514), under the name of *Cervus brovonii*. The latter has been identified by Prof. Busk among the fossil remains from Acton Green. The typical antler of Cuvier's species differs from Plate XVII. Fig. 4 of *C. brovonii*, in the possession of a palm of four points, and in being broken and badly restored with plaster at the point where

the third tye, *d*, of my figure joins the beam. Whether this kind of antler belongs to a well-marked variety of Fallow Deer or to a closely-allied species, I will not offer an opinion. It seems, however, safer to follow Professors Lartet, Gaudry, and most of the naturalists since the days of Cuvier, in keeping the fossil separate from the living forms, none of which present, so far as I know, a similar variation of antler. Till such an antler be found it is better to keep the animals apart in classification. And even if they be viewed as belonging to one species, they have only been met with in Pleistocene deposits in this country and in France, and they may reasonably be taken as visitors from the south, such as the contemporary hippopotami. In any case I would submit that they do not afford satisfactory grounds for believing with Dr. Sclater that the present distribution of the Fallow Deer in Northern and Central Europe by the hand of man is "an ancient fable." It is undoubtedly an ancient belief, and it is one which can be proved to some extent to be true by an appeal to the records of history.

To enter into the question of the introduction of Fallow Deer into Northern Europe would far outleap the limits of an article. A reference to Lenz's "Zoologie der Alten," and to Neckam's "Natural History," will show to what an extent the wealthy Romans and mediæval barons were in the habit of importing wild and rare animals for the chase, as well as for the sake of mere curiosity.

W. BOYD DAWKINS

#### THE ENGLISH ARCTIC EXPEDITION

SINCE our note of last week, the preparations for the Arctic Expedition have been advanced an important stage by the selection of Capt. Nares, of H.M.S. *Challenger*, to command the expedition. The choice is a happy one. Capt. Nares distinguished himself on board the *Resolute* in the Arctic Expedition of 1852-54, serving with McClintock, Meham, and Vesey Hamilton. He led the depot sledge for Meham's more extended journey. On that occasion he went over 665 miles in sixty-five days, while his efficient assistance enabled Meham to cover 1,006 miles of ground in ninety-four days. Nares was also foremost in providing amusement for the men during the winter quarters, one of the most essential qualifications for Arctic work. His recent experience in the *Challenger* will have made him thoroughly acquainted with the duties required of the commander of a scientific expedition. Commander A. H. Markham, of H.M.S. *Sultan*, will also take a prominent position in the expedition. Capt. Nares was at Hong Kong when he received the telegram offering the command, and probably by this time is on his way home. The command of the *Challenger* will, it is understood, be entrusted to Capt. Frank T. Thomson, now in command of H.M.S. *Modeste*, in China, and who was the first captain selected for official duties in the Royal Naval College at Greenwich.

We announced, a fortnight ago, that the Admiralty had selected Rear-Admiral Richards, C.B., F.R.S., Rear-Admiral Sir Leopold McClintock, F.R.S., and Rear-Admiral Sherard Osborn, C.B., F.R.S., to advise them as to the preparations that should be made. This Committee met for the first time on Tuesday week, and have been sitting periodically since.

We understand that the Foreign Office is about to inquire of the United States Government whether the stores sent to a depot on the west coast of Greenland for the use of the *Polaris* are desired to remain there, or whether they may be made available for our expedition. If the United States consent to transfer these stores, it will be of considerable advantage to our ships.

Active preparations are being made at the Royal Victoria Victualling Yard at Deptford, for provisioning

the ships which are to be engaged in the expedition. For this purpose 15,000 lb. of beef are undergoing a process of preservation.

It has been proposed, and no doubt very properly, that no persons not actually belonging to the navy can be allowed to take part in the expedition. This, however, effectually precludes any naturalist—as such—being attached to the staff. But the work to be done will principally consist in making collections to be worked up at home. And there is no reason to doubt that, as in the expedition of the *Erebus* and *Terror*, men will be found officially qualified for attachment to the expedition who will use every opportunity of securing for British science the credit of determining the nature of the fauna and flora of the regions in immediate proximity to the pole.

How great an interest is felt amongst naturalists as to the biological results of the expedition, may easily be imagined on reading the following passage from Markham's "Threshold of the Unknown Region" (pp. 201, 202):—

"The winter quarters were in a harbour called 'Thank God' Bay, in lat. 81° 38' N., and long. 61° 44' N., which the *Polaris* reached on Sept. 3. . . . The climate of the winter quarters was found to be much milder than it is several degrees further south. In June the plain surrounding 'Thank God' Bay was free from snow; a creeping herbage covered the ground, on which numerous herds of musk oxen found pasture, and rabbits and lemmings abounded. The wild flowers were brilliant, and large flocks of birds came northward in the summer."

The Kew Herbarium possesses four plants presented to it by Commander Markham, who obtained them from Dr. Bessels, of the *Polaris*. They were collected in 82° N. lat., "the most northern position from which any phanerogamic vegetation has hitherto been procured. The locality appears to have been on the east side of Smith's Sound. The species are *Draba alpina*, L.; *Cerastium alpinum*, L.; *Taraxacum Dens-leonis*, Desf. var.; and *Poa flexuosa*, Wahl." (NATURE, vol. viii. p. 487.)

The importance of obtaining information about the marine forms of life, both animal and vegetable, needs no insisting upon.

#### NOTES

It will interest our readers to hear that the Berlin Academy of Sciences has set aside a certain sum of money, which will enable it to call to Berlin eminent men of science, who will have no teaching duties to perform. Prof. Kirchhoff has finally decided to accept the directorship of the Observatory for Solar Physics, now being erected at Potsdam, and will proceed to Berlin to commence his duties in connection with its establishment, in the spring.

It is with great regret that we have to record the death of one of our most promising young naturalists, Mr. J. Traherne Moggridge, whose occasional contributions to these columns gave evidence of the powers of observation and research for which he was distinguished. His works on "Harvesting Ants and Trap-door Spiders," and "Contributions to the Flora of Mentone"—the latter beautifully illustrated by his own hand—contained important additions to our knowledge of different branches of science; a "Supplement" to the former of these works is just now issued from the press. Mr. Moggridge's kindly and unassuming manners had endeared him to a large circle of friends. A love of natural history was with him hereditary, being the grandson of Dillwyn, the monographer of the Coniferae, and joint author with Turner of the "Botanist's Guide." He died on Nov. 24, at the age of thirty-two, at Mentone, where the state of his health had compelled him to spend the winter for several years past. One of his great wishes

was to bring his fellow-sufferers to learn, as he had done, that an invalid may be useful and happy.

MR. J. R. HIND writes as follows to the *Times* of Dec. 7, with regard to a new comet:—"Having been favoured with a telegram from M. Stephan, Director of the Observatory of Marseilles, notifying the discovery of a comet by M. Borrelly about four o'clock this morning, we have been able to observe the comet this evening, its present position allowing of observation both evening and morning. The place telegraphed is—Dec. 6, at 16h. mean time at Marseilles; right ascension,  $239^{\circ} 56'$ ; polar distance,  $53^{\circ} 53'$ ; motion towards the north. An uncertainty as to the comparison star unfortunately prevents me from adding the result of my observations this evening, but the comet will be readily found with a good telescope."

In the same letter Mr. Hind points out that the zodiacal light has been conspicuous for the last few evenings, and that for several years past this phenomenon has been much more marked in December and January than about the vernal equinox.

SURGEON-MAJOR A. LEITH ADAMS, M.D., F.R.S., has been appointed to the Professorship of Zoology in the Royal College of Science at Dublin. Dr. Leith Adams is the author of several works in which natural history forms an important part; among them may be mentioned "Wanderings of a Naturalist in India, the Western Himalayas, and Cashmere," and "Field and Forest Rambles." His elaborate monograph on the "Fossil Elephants of the Maltese Islands" is also on the point of being published in the "Transactions" of the Zoological Society.

DR. J. W. HICKS has been elected to a Fellowship at Sidney Sussex College, Cambridge. Dr. Hicks was Senior in the Natural Science Tripos, and third among the Senior Optimes in 1870. He for some time held the Lectureship in Botany at St. Thomas's Hospital, and is now Demonstrator of Chemistry in the Cambridge University Laboratory. We may mention that though Sidney College was among the first in the University of Cambridge to offer Scholarships in Natural Science, yet its governing body has been chary of further encouraging the study by the bestowal of Fellowships. Ten years ago, indeed, the Senior in the Natural Science Tripos was rewarded by one; but Mr. Hicks has had to wait while wranglers in the "teens" have been preferred to him. We are glad that the College has made amends at last.

The course for the Natural Science Moderatorships in Trinity College, Dublin, has just been published. It consists of three parts:—1. Physiological and Comparative Anatomy: books recommended, Carpenter's "Human and Comparative Anatomy" and Rolleston's "Forms of Animal Life." 2. Zoology and Botany: books recommended in Zoology, Huxley's "Anatomy of Vertebrates," Foster's "Introduction to Embryology," Nicholson's "Manual of Zoology," and Gegenbaur's "Comparative Anatomy," by Vogt; in Botany, Hensley's "Course of Botany," by Masters, "Bentham's British Flora," and "Hofmeister on the Higher Cryptogamia," by Currey. 3. Geology and Physical Geography: books recommended, Dana's "Manual of Geology," Houghton's "Manual of Geology," and Keith Johnston's "Physical Geography." If a suggestion may be allowed, it would appear more in conformity with modern ideas that the subjects of the physiology and structure of plants and animals should be treated of as portions of botany and zoology; and surely the distribution of both plants and animals in space and in time appertains more to biology than to geology. Honours are now given in the natural sciences in the Sophister Classes, and the Professors of Geology, Zoology, and Botany give demonstrations in their respective subjects each term.

IN a note on the pollution of the Regent's Canal, the *Lancet* refers to the attempt which has been made to throw the chief

blame on the Zoological Society's Gardens, which pour their surface drainage and the contents of their bathing-tanks into the canal. We have, the *Lancet* states, carefully examined the Society's arrangements, and at once acquit them of any blame in the matter. For, though undoubtedly some of the urinary excretion of the animals is carried off by the surface drainage, still the amount is small, and the evil in that respect is more than counterbalanced by the large volume of water (50,000 gallons) daily poured into the canal. Indeed, if that amount of water were in any way diverted, the condition of the canal would, in dry seasons, become worse than it is at present. We were convinced that none of the solid excreta could find their way to the canal through any channel.

WE hope that the meeting held in London on Monday night under the presidency of H.R.H. the Duke of Edinburgh will be the means of securing the remaining 30,000*l.* needed to complete the modest sum wanted wherewith to extend the premises of the University of Edinburgh. The meeting was throughout a satisfactory one, and all the addresses, by H.R.H. the Duke of Edinburgh, the Earl of Derby, Prof. Huxley, Dr. Lyon Playfair, Prof. Allman, and others, were pervaded with a strong feeling as to the necessity for an all-important place in education being given to practical training in science. Indeed, it was distinctly stated by Prof. Huxley that the demand for space was not simply owing to the great increase of students in past years, but to the total and happy revolution which had been effected within the last twenty or thirty years in the mode of teaching all branches of physical science. When he was a medical student, the only branch of scientific study properly taught—namely, by practical instruction—was anatomy. It had now, however, come to be understood that what was true of anatomy was true of all branches of science—that no man could know anything about science unless he worked at it practically with his hands. That was the only knowledge on which he could really depend. Hence had arisen the demand for scientific laboratories, in which the student not only had the means and appliances of investigation, but had his work superintended by practical instructors. That demand had increased tenfold the requirements of any teaching body that would do its work worthily, and without the requisite accommodation the scientific teaching of the University could not possibly yield any sound and fruitful results. Moreover, it had come to be recognised that a man could not be a successful teacher, exercising a moral influence on his students which constituted the essential difference between a professor and a book, unless he was himself an original investigator, promoting and increasing knowledge. We have no doubt that we shall soon be able to announce that the whole 100,000*l.* has been subscribed.

A PAPER on "University Development in Scotland," reprinted from the *Perthshire Constitutional*, has been sent us. It takes Edinburgh University, the largest (it has 1,800 students this year) and best known of the Scottish Universities, as representative of the others, and points out several directions in which there is room for improvement. The writer takes the German University as in some sort a model, and points out the following defects in the Scottish Universities:—(1) The want of sufficiently extensive and suitable buildings; (2) There should be a material increase in the teaching staff; (3) There should be a better endowment of professorships; (4) Graduates should be encouraged to devote themselves to *original research* by the provision of liberally endowed professorships; (5) There should be more liberal superannuation of professors after a shorter period of service. The writer urges on all those who have been educated in Edinburgh, and on all who wish to see it keep its position, to lend a hand in the movement now on foot to raise a sum sufficient to provide the University with the additional buildings which are absolutely necessary to its efficiency.

At the meeting of the Dundee Town Council last Thursday, a letter from the directors of the Albert Institute of that town was read by Provost Cox, in which it was stated that a scheme for the erection of a college had been prepared, and the co-operation of the Council in the furtherance of the work was requested. It was proposed to establish a college in Dundee in connection with the St. Andrews University, and that at first the college should be opened with six chairs—namely, English Literature and Logic, Chemistry, Natural Philosophy, Engineering, Natural History or Greek and Latin, and Mathematics. To defray the expense of the erection of the college and to pay the salaries, 150,000*l.* would be required at the outside. If the college should succeed, it was proposed to add the following additional chairs—viz., Mental and Moral Philosophy, Political Economy, Ancient or Modern History, Latin and Greek or Natural History, Geography and Astronomy, and Physical Geography and Navigation. To endow these additional chairs a further sum of 75,000*l.* would be required. It was proposed that the management of the college should be carried on by the courts which at present manage the colleges at St. Andrews, the only addition to the University Courts of St. Andrews being that the following gentlemen should be members of that Court:—The Lord-Lieutenant of Forfarshire, the Convener of the County, the Sheriff and Sheriff-Substitute of Forfarshire, and the Provost of Dundee. The Council expressed themselves gratified at the movement, and while stating that they would be willing to give it their hearty co-operation, they resolved to call a special meeting for the consideration of the whole subject, to be held on Tuesday last. We would remind the organisers of the proposed new college of the great value of sound science-teaching to so important a manufacturing and commercial town as Dundee. There is nothing to hinder the wealthy merchants and manufacturers of Dundee starting a college at least equal to the Newcastle College of Science, and they should not rest until they possess an institution as efficient as Owens College, Manchester. This latter institution ought to be taken as a model, where all the so-called "faculties" are complete; a "College of Science," pure and simple, seems to us a blunder.

THE formal inauguration of the recently completed portions of the Edinburgh Museum of Science and Art is, we believe, to take place on Jan. 14 next, by a grand *conversazione* to be given by the Lord Provost in the Museum building.

A FURTHER instalment (the sixth part) of the new Government Map of Switzerland has recently appeared, containing the sheets Meiringen, Laax, Trons, Ilanz, Greina, Vrin, Anderer, Zweisimmen, Blumlisalp, Peccia, Blasca, and Maggia. Altogether 72 sheets are now published out of the 546 which will be necessary for the completion of the map. Those which have been issued are mainly of the central and north-west portions of the country, and regarding them we can only repeat the opinion that we have already expressed respecting the earlier sheets, namely, that they are equal and in some features superior to any maps of the kind that have yet appeared. Great as the cost of this map will be to the nation, we have no doubt that its expense will be repaid many times, in the facilities which it will afford in the construction of roads and railroads, and for many other purposes.

WE take the following from the *Academy*:—Now that the question of the endowment of research is being made so much a subject of discussion, it may interest our readers to learn the following particulars, which we take from the Swedish *Aftonbladet*. About a month since that newspaper drew attention to an appeal for funds made by the botanist Dr. Berggren, who is at present exploring the cryptogamic botany of the mountains of New Zealand. It appears that Dr. Berggren has already made some very valuable explorations, first in Spitzbergen in 1868, then in Greenland in 1870, and now has

been sent out to New Zealand with a stipend drawn from a sum of money left by a Herr Letterstedt for scientific purposes. Dr. Berggren writes that he has had signal success, especially in discovering species closely analogous to the Arctic forms with which he is familiar, but that his means are at an end. An effort made to induce the Government of Canterbury Province to vote him a sum of money was on the point of succeeding, when an economical frenzy took the Lower Legislative House, and the bill was thrown out. *Aftonbladet* laid these facts before its readers. Almost immediately, the proprietors of another newspaper, *Göteborg's Post*, generously forwarded a large sum towards the prosecution of the work, and private funds came in so rapidly that Dr. Berggren will be able to recommence his valuable explorations directly the next mail reaches New Zealand. This zealous response to the demands of science in so poor a country as Sweden does honour to the intelligence of its people.

A TELEGRAM dated Alexandria, Dec. 8, states that two reconnoitring expeditions, each consisting of eight European and twelve native officers and sixty-three soldiers, have been organised by the Egyptian Government, and have started for the Soudan, with the object of surveying the country between the Nile and the provinces of Darfour and Kordofan. Thence the expeditions will proceed to the Equator, west of the Albert Nyanza. They will repair the wells wherever necessary, and prepare maps, and will also report upon the population, climate, and commerce of the country through which they pass.

A MEETING of the local committee in connection with the recent meeting of the British Association, was held in Belfast on Saturday. The expense incurred has been about 1,800*l.*, leaving a surplus of more than 500*l.*, which the Executive Committee recommend should be divided among various local institutions.

WE would draw attention to a very valuable paper "On the Expediency of Protection for Patents," by Mr. F. J. Bramwell, C.E., F.R.S., published in the *Society of Arts Journal* for Dec. 4.

The additions to the Zoological Society's Gardens during the past week include two Glaucous Gulls (*Larus glaucus*) from Spitzbergen, presented by Mr. R. E. Beaumont; a Common Raccoon (*Procyon lotor*) from N. America, presented by Mr. T. Trimmell; a Bonnet Monkey (*Macacus radiatus*) from India, presented by Mrs. Phillips; a Solitary Tinamon (*Tinamus solitarius*) from Brazil, received in exchange; three Black-footed Penguins (*Spheniscus demersus*) from S. Africa, purchased; and a Capybara (*Hydrocherus capybara*) born in the Gardens.

## THE "CHALLENGER" EXPEDITION\*

### II.

THE following Table, taken from the chart, gives a good general idea of the distribution of the two formations with respect to depth. It cannot of course be taken as exact; the indications were jotted down from the impression of colour given at the time, and there is no hard and fast line between Globigerina ooze and grey ooze on the one hand, and between red clay and grey ooze on the other. This Table gives an average depth of 1,800 fathoms for our soundings in the Globigerina ooze. This is datum of no value, for we only rarely sounded in shallow water, and we know that this formation covers large areas at depths between 300 and 400 fathoms; but the mean maximum depth at which it occurs is important, and that may be taken from the Table as about 2,250 fathoms. The mean depth at which we find the transition grey ooze is 2,400 fathoms, and the mean depth of the red clay soundings is about 2,700 fathoms. The general concurrence of so many observations would go far to prove, what seems now to stand indeed in the position of an ascertained fact, that wherever the depth increases from about 2,200 to 2,600 fathoms, the modern chalk formation of the Atlantic and of other oceans pass into a clay.

\* Continued from p. 97.

No. of Station.	Nature of the Bottom.			No. of Station.	Nature of the Bottom.		
	Glob. Ooze.	Grey Ooze.	Red Clay.		Glob. Ooze.	Grey Ooze.	Red Clay.
<i>From Cape Finisterre to Teneriffe.</i>				<i>From Bermudas to the Azores (continued).</i>			
I.	1125	...	...	71	1675	...	...
	1975	...	...	72	1240	...	...
II.	470	...	...	73	1000	...	...
	1800	...	...	74	1350	...	...
III.	1000	...	...	76	900	...	...
VI.	1525	...	...	<i>From the Azores to Madira.</i>			
<i>From Teneriffe to St. Thomas.</i>				78	1000	...	...
1	1890	...	...	79	2025	...	...
2	1945	...	...	80	2660	...	...
4	2220	...	...	81	2675	...	...
5	...	2740	...	82	2400	...	...
6	...	2950	...	83	1650	...	...
7	...	2750	...	<i>From Madira to Cape Verde Islands.</i>			
8	...	2800	...	86	2300	...	...
9	...	3150	...	88	2300	...	...
10	...	2720	...	89	2400	...	...
11	...	2575	...	90	2400	...	...
12	2025	...	...	91	2075	...	...
13	1900	...	...	92	1975	...	...
14	1950	...	...	<i>From the Cape Verde Islands to St. Paul Rocks.</i>			
15	...	2325	...	95	2300	...	...
16	...	2435	...	97	2575	...	...
17	...	2385	...	98	1750	...	...
18	...	2675	...	102	...	2450	...
19	...	3000	...	104	...	2500	...
20	...	2975	...	105	...	2275	...
21	...	3025	...	106	1850	...	...
22	1420	...	...	107	1500	...	...
23	450	...	...	108	1900	...	...
<i>From St. Thomas to Bermudas.</i>				<i>From the St. Paul Rocks to S. Salvador.</i>			
25	...	3875	...	110	2275	...	...
26	...	2800	...	111	2475	...	...
27	...	2960	...	112	2200	...	...
28	...	2850	...	115	2150	...	...
29	...	2700	...	116	2275	...	...
30	...	2600	...	<i>From S. Salvador to Tristan d'Acunha.</i>			
31	...	2475	...	129	...	2150	...
32	...	2250	...	130	...	2350	...
...	...	1820	...	131	2275	...	...
<i>From Bermudas to Halifax.</i>				132	2050	...	...
37	...	2650	...	133	1900	...	...
38	...	2600	...	134	2025	...	...
39	...	2550	...	<i>From Tristan d'Acunha to the Cape of Good Hope.</i>			
42	...	2425	...	137	...	2550	...
44	...	1700	...	138	...	2050	...
<i>From Halifax to Bermudas.</i>				139	...	2325	...
50	...	1250	...	140	...	1250	...
51	...	2200	...	<i>From the Cape of Good Hope to Kerguelen Island.</i>			
52	...	2800	...	143	1900	...	...
53	...	2650	...	144	1570	...	...
54	...	2650	...	146	1375	...	...
55	...	2500	...	147	1600	...	...
<i>From Bermudas to the Azores.</i>				<i>From Kerguelen Island to Melbourne.</i>			
58	...	1500	...	158	1800	...	...
59	...	2360	...	159	2150	...	...
60	...	2575	...	160	...	2600	...
61	...	2850	...				
62	...	2875	...				
63	...	2750	...				
65	...	2700	...				
66	...	2750	...				
67	...	2700	...				
68	...	2175	...				
69	...	2200	...				
70	1675	...	...				

The nature and origin of this vast deposit of clay is a question of the very greatest interest; and although I think there can be no doubt that it is in the main solved, yet some matters of detail are still involved in difficulty. My first impression was that it might be the most minutely divided material, the ultimate sediment produced by the disintegration of the land, by rivers and by the action of the sea on exposed coasts, and held in suspension and distributed by ocean currents, and only making itself manifest in places unoccupied by the Globigerina oze. Several circumstances seemed, however, to negative this mode of origin. The formation seemed too uniform; whenever we met with it it had the same character, and it only varied in composition in containing less or more carbonate of lime.

Again, we were gradually becoming more and more convinced that all the important elements of the Globigerina oze lived on the surface; and it seemed evident that so long as the conditions on the surface remained the same, no alteration of contour at the bottom could possibly prevent its accumulation; and the surface conditions in the Mid-Atlantic were very uniform, a moderate current of a very equal temperature passing continuously over elevations and depressions, and everywhere yielding to the townet the oze-forming foraminifera in the same proportion. The Mid-Atlantic swarms with pelagic mollusca, and in moderate depth the shells of these are constantly mixed with the Globigerina oze, sometimes in number sufficient to make up a considerable portion of its bulk. It is clear that these shells must fall in equal numbers upon the red clay, but scarcely a trace of one of them is ever brought up by the dredge on the red clay area. It might be possible to explain the absence of shell-secreting animals living on the bottom, on the supposition that the nature of the deposit was injurious to them; but then the idea of a current sufficiently strong to sweep them away is negated by the extreme fineness of the sediment which is being laid down; the absence of surface shells appears to be intelligible only on the supposition that they are in some way removed.

We conclude, therefore, that the "red clay" is not an additional substance introduced from without, and occupying certain depressed regions on account of some law regulating its deposition, but that it is produced by the removal, by some means or other, over these areas of the carbonate of lime, which forms probably about 98 per cent. of the material of the Globigerina oze. We can trace, indeed, every successive stage in the removal of the carbonate of lime in descending the slope of the ridge or plateau when the Globigerina oze is forming to the region of the clay. We find, first, that the shells of pteropods and other surface mollusca, which are constantly falling on the bottom, are absent, or if a few remain they are brittle and yellow, and evidently decaying rapidly. These shells of mollusca decompose more easily and disappear sooner than the smaller and apparently more delicate shells of rhizopods. The smaller foraminifera now give way and are found in lessening proportion to the larger; the coccoliths first lose their thin outer border and then disappear, and the clubs of the rhabdoliths get worn out of shape and are last seen under a high power as infinitely minute cylinders scattered over the field. The larger foraminifera are attached, and instead of being vividly white and delicately sculptured, they become brown and worn, and finally they break up, each according to its fashion; the chamber-walls of Globigerina fall into wedge-shaped pieces, which quickly disappear, and a thick rough crust breaks away from the surface of Orbulina, leaving a thin inner sphere, at first beautifully transparent, but soon becoming opaque and crumbling away.

In the meantime the proportion of the amorphous "red clay" to the calcareous elements of all kinds increases until the latter disappear, with the exception of a few scattered shells of the larger foraminifera, which are still found even in the most characteristic samples of the "red clay."

There seems to be no room left for doubt that the red clay is essentially the insoluble residue, the ash, as it were, of the calcareous organisms which form the Globigerina oze after the calcareous matter has been by some means removed. An ordinary mixture of calcareous foraminifera with the shells of pteropods, forming a fair sample of Globigerina oze from near St. Thomas, was carefully washed and subjected by Mr. Buchanan to the action of weak acid; and he found that there remained after the carbonate of lime had been removed, about one per cent. of a reddish mud consisting of silica, alumina, and the red oxide of iron. This experiment has been frequently repeated with different samples of Globigerina oze, and always with the result that a small proportion of a red sediment remains which possesses all the characters of the red clay.

In the Globigerina ooze siliceous bodies, including the spicules of sponges, the spicules and tests of radiolarians, and the frustules of diatoms occur in appreciable proportion; and these also diminish in number, and the more delicate of them disappear in the transition from the calcareous ooze to the red clay.

I have already alluded to the large quantity of nodules of the prode of manganese which were brought up by the trawl from the red-clay area on the 13th of March. Such nodules seem to occur universally in this formation. No manganese can be detected in the Globigerina ooze; but no sooner has the removal of the carbonate of lime commenced than small black grains make their appearance, usually rounded and mammillated on the surface, miniatures, in fact, of the larger nodules which abound in the clay; and at the same time any large organic body, such as a shark's tooth, that may happen to be in the ooze is more or less completely replaced by manganese; and any inorganic body, such as a pebble or a piece of pumice, is coated with it as a fine black mammillated layer. It is not easy to tell what the proportion of manganese in the red clay may be, but it is very considerable. At station 160, on the 13th of March, the trawl brought up nearly a bushel of nodules from the size of a walnut to that of an orange, but these were probably the result of the sifting of a large quantity of the clay. The manganese is doubtless set free like the iron by the decomposition of the organic bodies and tests. It is known to exist in the ash of some algae to the amount of four per cent.

The interesting question now arises as to the cause and method of the removal of the carbonate of lime from the cretaceous deposit, and on this matter we are not yet in a position to form any definite conclusion.

One possible explanation is sufficiently obvious. All sea-water contains a certain proportion of free carbonic acid, and Mr. Buchanan believes that he finds it rather in excess in bottom-water from great depths. At all events the quantity present is sufficient to convert into a soluble compound, and thus remove a considerable amount of carbonic lime. If the balance of supply be very delicately adjusted, it is just conceivable that the lime in the shells in its fine state of subdivision having been attacked by the sea-water from the moment of the death of the animal, may be entirely dissolved during its retarded passage through the half mile or so of water of increasing density. The bottom-water in these deep troughs has been lost at the surface, a great deal of it in the form of circumpolar freshwater ice; and though fully charged with carbonic acid, it is possible that it may be comparatively free from carbonate of lime, and that its solvent power may thus be greater.

The red clay, or more probably the circumstances which lead to its deposition, seem on the whole unfavourable to the development of animal life. Where its special characters are most marked, no animals which require much carbonate of lime for the development of their tissues or their habitations appear to exist. Our growing experience is, that although animal life is possible at all depths after a certain depth, say 1,500 fathoms, its abundance diminishes. This would seem to indicate that the extreme conditions of vast depths are not favourable to its development; and one might well imagine that the number of shell-building animals might decrease until the supply of lime was so far reduced as to make it difficult for them to hold their own against the solvent power of the water of the sea—just as in many districts where there is little lime, the shells of land and freshwater molluscs are light and thin, and the animals themselves are stunted and scarce.

It seems, however, that neither the extreme depth at which the red clay is found, nor the conditions under which it is separated and laid down, are sufficient entirely to negative the existence of living animals, even of the higher invertebrate orders. In several of the hauls we brought up holothurids of considerable size, with the calcareous neck-rings very rudimentary, and either no calcareous bodies in the test or a mere trace of such. Nearly every haul gave us delicate branching Bryozoa with the zoecium almost membranous. One fortunate cast, about 150 miles from Sombbrero, brought up from a depth of 2,975 fathoms very well-marked red mud, which did not effervesce with hydrochloric acid. Entangled in the dredge, and imbedded in the mud, were many of the tubes of a tube-building annelid, several of them 3 in. to 4 in. long, and containing the worm, a species of *Myrioclele*, still living. The worm-tubes, like all the tests of foraminifera from the same dredging, were made up of particles of the red clay alone.

It seems evident, from the observations here recorded, that clay, which we have hitherto looked upon as essentially the pro-

duct of the disintegration of older rocks, may be under certain circumstances an organic formation like chalk; that as a matter of fact, an area on the surface of the globe, which we have shown to be of vast extent, although we are still far from having ascertained its limits, is being covered by such a deposit at the present day.

It is impossible to avoid associating such a formation with the fine, smooth, homogeneous clays and schists, poor in fossils, but showing worm-tubes and tracks, and bunches of doubtful branching things, such as *Oldhamia*, siliceous sponges, and thin-shelled peculiar shrimps. Such formations more or less metamorphosed are very familiar, especially to the student of palæozoic geology, and they often attain a vast thickness. One is inclined, from this great resemblance between them in composition and in the general character of the included fauna, to suspect that these may be organic formations, like the modern red clay of the Atlantic and Southern Sea, accumulations of the insoluble ashes of shelled creatures.

The dredging in the red clay on the 13th of March was unusually rich. The bag contained examples, those with calcareous shells rather stunted, of most of the characteristic deep-water groups of the Southern Sea, including *Umbellularia*, *Euplectella*, *Pterocrinus*, *Brisinga*, *Ophioglypha*, *Pourtalesia*, and one or two *Mollusca*. This is, however, very rarely the case. Generally the red clay is barren, or contains only a very small number of forms.

On the 11th of February, lat. 60° 52' S., long. 80° 20' E., and March 3, lat. 53° 55' S., long. 108° 35' E., the sounding instrument came up filled with a very fine cream-coloured paste, which scarcely effervesced with acid, and dried into a very light impalpable white powder. This, when examined under the microscope, was found to consist almost entirely of the frustules of diatoms, some of them wonderfully perfect in all the details of their ornament, and many of them broken up. The species of diatoms entering into this deposit have not yet been worked up, but they appear to be referable chiefly to the genera *Fragilaria*, *Cocconeidiscus*, *Chaetoceros*, *Asteromphalus*, and *Dictyocha*, with fragments of the separated rods of a singular siliceous organism, with which we were unacquainted, and which made up a large proportion of the finer matter of this deposit. Mixed with the diatoms there were a few small Globigerinae, some of the tests and spicules of radiolarians, and some sand particles; but these foreign bodies were in too small proportion to affect the formation as consisting practically of diatoms alone. On the 4th of February, in lat. 52° 29' S., long. 71° 36' E., a little to the north of the Heard Islands, the tow-net, dragging a few fathoms below the surface, came up nearly filled with a pale yellow gelatinous mass. This was found to consist entirely of diatoms of the same species of that found at the bottom. By far the most abundant was the little bundle of siliceous rods, fastened together loosely at one end, separating from one another at the other end, and the whole bundle loosely twisted into a spindle. The rods are hollow, and contain the characteristic endochrome of the Diatomaceæ. Like the Globigerina ooze, then, which it succeeds to the southward in a band apparently of no great width, the materials of this siliceous deposit are derived entirely from the surface and intermediate depths. It is somewhat singular that diatoms did not appear to be in such large numbers on the surface over the diatom ooze as they were a little further north. This may perhaps be accounted for by our not having struck their belt of depth with the tow-net; or it is possible that when we found it on the 11th of February the bottom deposit was really shifted a little to the south by the warm current, the excessively fine flocculent debris of the diatoms taking a certain time to sink. The belt of diatom ooze is certainly a little further to the southward in long. 80° E. in the path of the reflux of the Agulhas current than in long. 103° E.

All along the edge of the ice-pack—everywhere, in fact, to the south of the two stations, on the 11th of February on our southward voyage, and on the 3rd of March on our return—we brought up fine sand and greyish mud, with small pebbles of quartz and felspar, and small fragments of mica-slate, chlorite-slate, clay-slate, gneiss, and granite. This deposit, I have no doubt, was derived from the surface like the others, but in this case by the melting of icebergs and the precipitation of foreign matter contained in the ice.

We never saw any trace of gravel or sand, or any material necessarily derived from land, on an iceberg. Several showed vertical or irregular fissures filled with discoloured ice or snow; but when looked at closely the discoloration proved usually to be very slight, and the effect at a distance was usually due to the



foreign material filling the fissure reflecting light less perfectly than the general surface of the berg. I conceive that the upper surface of one of these great tabular southern icebergs, including by far the greater part of its bulk, and culminating in the portion exposed above the surface of the sea, was formed by the piling up of successive layers of snow during the period, amounting perhaps to several centuries, during which the ice-cap was slowly forcing itself over the low land and out to sea over a long extent of gentle slope, until it reached a depth considerably above 200 fathoms, when the lower specific weight of the ice caused an upward strain which at length overcame the cohesion of the mass, and portions were rent off and floated away. If this be the true history of the formation of these icebergs, the absence of all land débris in the portion exposed above the surface of the sea is readily understood. If any such exist, it must be confined to the lower part of the berg, to that part which has at one time or other moved on the floor of the ice-cap.

The icebergs, when they are first dispersed, float in from 200 to 250 fathoms. When, therefore, they have been drifted to latitudes of  $65^{\circ}$  or  $64^{\circ}$  S., the bottom of the berg just reaches the layer at which the temperature of the water is distinctly rising, and it is rapidly melted, and the mud and pebbles with which it is more or less charged are precipitated. That this precipitation takes place all over the area where the icebergs are breaking up constantly, and to a considerable extent, is evident from the fact of the soundings being entirely composed of such deposits; for the diatoms, Globigerina, and radiolarians are present on the surface in large numbers; and unless the deposit from the ice were abundant it would soon be covered and masked by a layer of the exuvie of surface organisms.

### SCIENTIFIC SERIALS

Poggendorff's *Annalen der Physik und Chemie*, No. 6.—The first paper, by G. Lundquist, On the reflection of light from the outside of isotropic bodies, is reprinted from the "Transactions" of the Royal Society of Upsala.—Dr. H. Högström contributes a memoir On the Medium in electrical induction, in which, following up the experiments of Riess, he examines Faraday's theory of electrical induction by polarisation of the medium, and describes in detail the apparatus with which he experimented, tabulates his results, and agrees with Riess's induction as to a direct influx of electricity.—The next article comprises a series of communications from the Mineralogical Institute of the University of Strasburg, in which Paul Groth treats of the crystalline form and thermo-electric properties of smaltine or arsenical cobalt. Its chemical formula is very variable,  $R = (Co, Ni, Fe) As_3$ . Eight samples from different localities, which contribute a better knowledge of the hemihedral forms of the species, are discussed. He concludes that some of the forms hitherto regarded as holohedral are hemihedral forms with parallel sides. As with iron pyrites and cobalt-glance, with which it is isomorphous, one part of the crystal is negative towards copper, while the other half is positive.—Dr. Hinz treats of the chemical composition of leadhillite. Prof. Laspeyres two years ago described a mineral from Iglesias, in Sardinia, under the name of maxite, of which the formula was  $5PbSO_4 + 9PbCO_3 + 4PbO + 5H_2O$ . M. Bertrand, of Paris, soon after published an account of leadhillite from the same neighbourhood. The author proves that the two minerals are identical, and that the formula of leadhillite is not  $PbSO_4 + 3PbCO_3$  as hitherto believed, but  $2PbSO_4 + 4PbCO_3 + PbO + 2H_2O$ . The next paper, by the same author, is crystallographic researches on the combination of aldehyde with the aromatic hydrocarbons. The chemical composition and crystalline forms are given of ditolylchloroethane, diphenyltribromoethane, diphenyltrichloroethane, diphenyldibromoethane, dimonomethyltrichloroethane, &c. All these bodies belong to the monoclinic system.—Dr. A. Arzruni gives a short note on tungstic acid in willemite. The next paper by the same author is "Optical researches on the turpentinehydrates," which he follows by crystallographic and optical researches on compounds of urea. His last paper is on two isomorphous substances derived from benzol.—F. Zollner prints his important paper on the aggregation and position of the sun-spots, and concludes that they are cooled incandescent products.—Dr. Karl Braun contributes studies on the earth's magnetism.—Among the reprinted papers are Dr. Andrews' on ozone and Prof. Wright's on the polarisation of the zodiacal light.

*Memorie della Societa Spettroscopisti Italiani*, September 1874.—This number contains a paper by Mr. J. N. Lockyer, describing certain phenomena seen when examining the spectrum of the electric light through a mass of sodium vapour in a tube. When this is done, the sodium lines are seen to shade gradually off, sometimes on one side, sometimes on both, the boundary of the shading being curved and sometimes limited by a bright line.—There is also another paper by the same author, On experiments on the absorption of a great thickness of sodium and iodine vapour in a tube 5 ft. long. After mentioning that it had been hitherto assumed that a great thickness of gas causes its radiation, and therefore its absorption, to become more continuous, he states that, on generalising his work, it appears that when the density of a vapour is increased, a continuous spectrum is approached in the case of the metallic elements of low specific gravity by the widening of their lines, and in that of the elements of high sp. gr. by the increase of the number of lines. To test this, the absorption of sodium vapour in a 5 ft. tube was observed, and the D line was found to be no thicker than the same line produced by a test-tube full of the vapour, and the line was thicker than the D-line in the solar spectrum, in which spectrum all the short lines are reversed.—Father Secchi communicates a letter of A. T. Arcimis, detailing observations on the spectra of meteorites. The spectra of all seem to be continuous, but wanting in the violet, that colour of the spectrum predominating according to its colour to the naked eye. The sodium line was visible in the trail of some, as also were the lines of magnesium.—G. De Sisa gives a table of the solar spots observed at Palermo from June to September.—A table of the chromosphere, as seen during February and March last at Palermo, is added to this number.—E. Fergola contributes a lengthy paper on the position of the axis of rotation of the earth with respect to its axis of figure.

### SOCIETIES AND ACADEMIES

#### LONDON

Linnean Society, Dec. 3.—Dr. G. J. Allman, F.R.S., president, in the chair.—Mr. Jas. Brogden, Sir Edmund Buckley, Bart., M.P., Messrs. Jas. Cowherd, P. Duffy, C. C. Dupré, A. M. Ross, and J. W. Silver were severally elected Fellows of the Society.—Prof. Huxley read a paper On the classification of the animal kingdom, which will be found in another column. An interesting discussion followed, in which the President, Mr. Busk, Mr. H. G. Seeley, Mr. Stewart, Dr. Murie, and others took part.

Chemical Society, Dec. 3.—Mr. W. H. Perkins, F.R.S., in the chair.—A paper was read by Mr. S. Lupton On the formulae of the alums; the next was a notice On the colour of cupric chloride, by Mr. W. N. Hartley, who finds that the crystals of the salt when quite dry have a blue colour, and not a green, as they usually appear when slightly moist.—Papers were also read On the oxidation of the essential oils, Part II, by Mr. C. T. Kingzett; On the purification and boiling-point of methyl hexyl carbinol, by Mr. E. Neison; and a note on the boiling-point of methyl hexyl carbinol, by Dr. C. Schorlemmer, F.R.S.

Zoological Society, Dec. 1.—Dr. A. Günther, F.R.S., in the chair.—A letter was read from the Rev. S. J. Whitmee, of Samoa, stating that he had sent home for the Society some birds and a pair of the Samoan Bat, which had lately been described by Mr. Alston as *Pteropus whitmeei*. Particulars were given as to the habits of the latter.—A communication was read from Mr. Henry W. Piers, of Capetown, containing remarks on some specimens of *Gymnetrus* in the museum at Capetown.—The Secretary announced that Col. R. S. Tickell, late of H.M. Indian Army, had presented to the Society's library a very finely illustrated MS. work, in seven small folio volumes, on the Ornithology of India.—A communication was read from Mr. J. Brazier, of Sydney, N.S.W., giving descriptions of eleven new species of terrestrial and marine shells from North-east Australia.—A paper, by Messrs. P. L. Slater and O. Salvin, was read on birds collected by Mr. Whitley in Western Peru, being the eighth communication made by the authors on this subject.—A communication was read from Mr. H. Whitley, containing some further notes on Humming Birds collected by him in High Peru.—Mr. A. G. Butler read a paper in which he gave descriptions of three new species of homopterous insects from various parts of the world.—Mr. A. H. Garrod gave some further particulars on the mechanism of the "shew off" in the Bustards, and described the peculiar structure of the *frenum lingua* recently noticed in a young male of the Great Bustard.

Royal Horticultural Society, Dec. 2.—Scientific Committee.—Andrew Murray, F.L.S., in the chair.—Models were exhibited of the fruit of *Slephanotis floribunda*.—The Chairman made a communication on the Larch disease. It appeared to produce a local destruction and ulceration of the cambium layer; the trees affected by it also suffered from "piping," i.e., premature decay of the heart wood. The disease was now beginning to attack the Spruce and *Pinus excelsa*.—Prof. Thiselton Dyer exhibited part of the stem of a *Calamus* from Sikkim, in which the midrib of a sheathing leaf had produced an adventitious bud on its under side.—Dr. Denny raised a discussion on the possibility of superfermentation in plants.

General Meeting.—W. Lindsay, secretary, in the chair.—Prof. Thiselton Dyer commented on the investigations lately undertaken with respect to the potato disease. Prof. de Bary was disposed to believe that heterocercism occurred in the case of the potato parasite, that is to say, that part of its life was passed upon some other host besides the potato. Mouillefert had recently suggested that this might be clover, and Mr. Jenkins, secretary of the Royal Agricultural Society, supposed that both clover and straw might harbour the unknown stage of *Peyronospora infestans*, and that this "would justify the prevailing opinion that farm-yard manure encourages the ravages of the potato disease, especially when applied in spring, because the spores of the fungus would be in the manure which had been used for litter."

Royal Microscopical Society, Dec. 2.—Chas. Brooke, F.R.S., president, in the chair.—A paper by Dr. Hudson, "On the discovery of some new male Kolifers," was read by the secretary, in the absence of the author. It described the male forms of *Lascinularia*, *Floscularia*, and *Notommatia*, hitherto believed to be unisexual, and was illustrated by a number of very beautiful diagrams.—A paper by Dr. Schmidt, of New Orleans, upon the development of the small blood-vessels in the human embryo, was taken as read.

Victoria (Philosophical) Institute, Dec. 7.—The proceedings were commenced by the election of sixty-five new members and associates. It was stated that the total number of subscribing members was now 544.—Prof. H. Alleyne Nicholson, M.D., read his paper on the bearing of certain palaeontological facts upon the Darwinian theory of the Origin of Species, and on the general doctrine of Evolution. The paper, after discussing the nature of the views usually held as to Evolution, examined in detail the difficulties which Palaeontology offers to the acceptance of the Darwinian theory of the Origin of Species, and the arguments employed by Mr. Darwin to lessen or remove these difficulties.

EDINBURGH

Royal Society, Dec. 7.—Sir W. Thomson, president, in the chair.—The President delivered to Prof. Tait the Keith Prize for the biennial period (1871-1873), which had been awarded to him by the Council for a memoir published in the last part of the Transactions of the Society, entitled "First Approximation to a Thermo-Electric Diagram."—The President then delivered an address on "Stability of Steady Motion."

PARIS

Geographical Society, Nov. 18.—President, M. Delesse.—M. Vinot announced that an interesting discovery had been made on the summit of the Puy de Dôme, of the ruins of an ancient monument which seems to date from the first century after the conquest of Gaul by the Romans.—Dr. Hamy, in the name of M. de la Porte, chief of the last expedition to Cambodia, read a note containing interesting details concerning the country which he has explored. With the exception of a few principal points, Cambodia is in great part still unexplored. A new map of the country by M. de la Porte and M. Moura, representing the French protectorate in Cambodia, will shortly be published. M. de la Porte believes that many archeological discoveries of the highest importance are yet to be made in Cambodia, and he expects considerable results from the exploration about to be made by M. Harmand in the regions to the west of the French colony.

Academy of Sciences, Nov. 30.—M. Frémy in the chair.—The following papers were read:—Note on two properties of the ballistic curve, whatever may be the exponent of the power of the velocity to which the resistance of the medium is proportional, by M. H. Résal.—On the capillary theory according to the Liliaceae, by M. A. Trécul.—On the distribution of the bands in primary spectra, by M. G. Salet.—On the mechanism of the intra-stomachal solution of the gastric concretions of crabs,

by M. S. Chantran.—M. Dumas called the attention of the Academy to the recent appearance of Phylloxera in Pégny, near Geneva, and M. Pasteur made some observations thereon. Letters from M. Schnetzer and M. Max Cornu to M. Dumas on the subject of Phylloxera were also read.—Letter from M<sup>me</sup>. V<sup>e</sup> Bouchard-Huzard to the President, offering to the Academy documents relating to a great number of its members; documents composing the collection made by J. B. Huzard.—On the heat disengaged by the combination of hydrogen with the metals, by M. J. Moutier. The author has shown that the formula deduced by Clausius from Carnot's theorem for changes of state is applicable to dissociation. The formula is—

$$L = AT(v - v') \frac{dp}{dP}$$

L representing the heat of combination of two bodies at the absolute temperature T under the pressure p, equal to the tension of dissociation at that temperature, v the specific volume of the dissociated elements, and v' the specific volume of the compound under the same conditions of temperature and pressure. A is the thermal equivalent of work. From this formula the value of L can be found when we have tables of the tensions of dissociation of the compound at different temperatures.—The recent experiments of M.M. Troost and Hautefeuille have made known these tensions for combinations of hydrogen with palladium, potassium, and sodium, at different temperatures.—Orbit, period of revolution, and mass of the double star 70 ρ Oplicus, by M. C. Flammarion.—Observations of the zodiacal light at Toulouse, the 16th, 21st, and 23rd of September; 9th, 10th, and 11th Oct.; 10th and 12th of November, 1874, by M. Gruly.—Laws of double internal reflection in birefringent uni-axial crystals, by M. Abria.—Researches on the decomposition of certain salts by water, by M. A. Ditté. In this third note the author has examined the double sulphate of potassium and calcium.—On the additive product of propylene and hypochlorous acid, by M. L. Henry.—Employment of gas-retort carbon in the distillation of sulphuric acid, by M. F. M. Raoult.—Influence of boiling distilled water on Fehling's solution, by MM. E. Boivin and D. Loiseau.—Iron in the organism, by M. P. Picard.—On experimental septicæmia, by M. V. Feltz.—On the birth and evolution of bacteria in organic tissues sheltered from the air, by M. A. Serval.—Note on a stony concretion, by Dr. T. L. Phipson.—On some passages in "Stan. Bell," from which it may be concluded that *Amaranthus blitum* is cultivated in Circeia for the nitre which it contains; extract from a letter from M. Brosset.—Note on the lowering and natural elevation of lakes, by M. Dausse.—The compound flute during the reindeer period, by M. Ed. Piette.

BOOKS AND PAMPHLETS RECEIVED

BRITISH.—The Straits of Malacca, Indo-China, and China; J. Thompson, F.R.G.S. (Simpson Low).—Travels in South America: Paul Marcoy (Blackie and Son).—Supplement to Harvesting Ants and Trapdoor Spiders; J. Tharner Moggridge, F.L.S., F.Z.S., and Rev. O. Pickard-Cambridge (L. Reeve and Co.).—English Men of Science; their Nature and Culture; Francis Galton, F.R.S. (Macmillan and Co.).—Selections from Berkeley; Alex. Campbell Fraser, LL.D. (Clarendon Press).—Elements of Animal Physiology; John Angell (Wm. Collins).—Elements of Magnetism and Electricity; John Angell (Wm. Collins).—Principles of Metal Mining; J. H. Collins, F.G.S. (Wm. Collins).—Evolution and the Origin of Life; H. Charlton Bastian, M.A., M.D., F.R.S. (Macmillan and Co.).—The Forces which act on the Circulation of the Blood; Andrew Buchanan, M.D. (J. and A. Churchill).

CONTENTS

	PAGE
ON THE CLASSIFICATION OF THE ANIMAL KINGDOM. By Prof. HUXLEY, SEC. R.S.	101
THE "TIMES" ON THE IMPORTANCE OF SCIENTIFIC RESEARCH	102
AGRICULTURAL EDUCATION. By Prof. THOMAS BALDWIN	104
THE SHEEP	106
CLOUET'S PRACTICAL CHEMISTRY	107
LETTERS TO THE EDITOR:—	
Royal Agricultural Society and the Potato Disease.—H. M. JENKINS	109
ANABAS SCANDENS.—G. E. DOBSON	109
FERTILISATION OF FLOWERS BY INSECTS, VIII. By Dr. HERMANN MULLER (With Illustrations)	110
THE TRANSIT OF VENUS	112
ON THE NORTHERN RANGE OF THE FALLOW DEER IN EUROPE. By Prof. W. BOYD DAWKINS, F.R.S.	114
THE ENGLISH ARCTIC EXPEDITION	114
NOTES	114
THE "CHALLENGER" EXPEDITION, II. By Prof. WYVILLE THOMSON, F.R.S.	116
SCIENTIFIC SERIALS	119
SOCIETIES AND ACADEMIES	119
BOOKS AND PAMPHLETS RECEIVED	120

THURSDAY, DECEMBER 17, 1874

## THE TRANSIT OF VENUS

IT is not too early to congratulate the world of science upon a grand triumph. The telegrams which have of late been flowing in almost incessantly from all parts of the Northern Hemisphere—now from far Japan and from Siberia, recording the success of French, Russian, and American parties; and now from America, giving fuller details regarding the doings of the latter—leave no doubt whatever that the weather has been better at the northern stations than might have been expected, seeing that the observations have been made in the winter half of the year.

Nor has the Northern Hemisphere been the only one to give us news. We already know of success at Melbourne and Hobart Town, at which place was an American party similarly equipped to those at Wladivostok in Asiatic Russia, and at Nagasaki; and Prof. Newcomb has already telegraphed to the *Times* that the eighty photographs taken by the American method at these places, combined with the 113 taken at Hobart Town, are sufficient to give us a value of the solar parallax with a probable error of perhaps one-fortieth of a second of arc. This gives a foretaste of what photography is likely to do for us in this and the coming Transit of 1882.

Before we proceed to detail the observations at the various stations, it will be well to re-state the various ways in which a Transit of Venus may be observed. This we will do almost in the words employed in a former article.

We have the utilisation of a Transit—

(a) By the determination of times of contact at different stations, combined with a knowledge of the longitudes of those stations.

(b) By the determination of the least distances between the centres of the sun and Venus during the Transit, observed from different stations.

This last determination may be made by—

(1) What is called Halley's method; or, if we wish that the world should forget a great work accomplished by a former great Astronomer Royal, we may term this the "method of durations."

(2) By the Photographic method; or,

(3) By the Heliometric method.

Premising that the first method of determination (a) was devised by Delisle, we have now our nomenclature sufficiently complete for present purposes, and we may begin with the stations at which this method can be best employed. Of these we have four groups: Accelerated Ingress, Sandwich Islands; Retarded Ingress, Kerguelen's Land, Heard or Macdonald Island, Mauritius, Bourbon, and Rodriguez; Accelerated Egress, Campbell Island, Emerald Island, Auckland Island, Royal Company's Island, and New Zealand; Retarded Egress stations in Western Russia, Persia, and Egypt.

Of these groups the northern ones can be used for Delisle's method solely, as only Ingress or Egress is seen; Ingress in the Sandwich Island group, Egress in the Western Asiatic group. But the southern groups may be used for all methods.

For the methods we have grouped under (b), stations in

Eastern and Southern Asia, combined with those in the Southern seas which we have already named, and stations between them, such as Melbourne and Adelaide, may be employed.

From the Sandwich Islands, Kerguelen's Land, Heard Island, Mauritius, Bourbon, and Rodriguez we have of course not yet heard; we consequently know nothing of Delislean observations of Ingress.

Of observations of Accelerated Egress on this method we know nothing, but with regard to Retarded Egress we know that the English and Russian parties in Egypt have been wonderfully successful. At Teheran, a second class Russian station, but better adapted than Egypt for applying the Delislean method, the observations were a perfect success. At Ispahan, a German party obtained nineteen good photographs; but north of this, in the most favourable point of all, the Russian parties at Ormsk, Astrachan, and in all that region, there was complete failure.

From the English party several telegrams have been received since our last number appeared: a long one by the *Times*, and several shorter ones by the Astronomer Royal. These we give:—

"Cairo, Dec. 9.—The Transit of Venus was observed in all its phases by the astronomers of the Government Expedition in Egypt this morning, at the Central Station at Mokattam Heights. It was observed by Captain Orde and Mr. F. M. Newton at Suez, and by Mr. Hunter at Thebes. It was photographed by Captain Abney, and observed by Dr. Auwers and Prof. Dollen, also by Colonel Campbell and others. During the last three days the weather has been very bad, and this morning the telescopes in Cairo and Suez were directed to the eastern quarter of a sky clouded over, showing, however, a few breaks, which gave hope. Glimpses through the clouds exhibited Venus as a distinct black spot on the sun, but no opportunity was given for a micrometer measurement for nearly half an hour after sunrise; then a few chances were given through the openings in the clouds. A decided opening occurred of a very hopeful character about ten minutes before contact, and after one more cloud, which passed over two or three minutes only before the critical epoch, the observation of internal contact was made satisfactorily at every station in Egypt, and the photoheliograph has done its work well. The sky was quite clear for the measurement of cusps and any observations that could be made of external contact. The astronomers are satisfied with their observations. The phases are declared in Cairo to have so closely resembled those shown by Sir George Airy's model at Greenwich that it was hard to divest the mind of the idea that it was only model practice again. The Khedive has taken a warm interest in the work, and guarded the Mokattam station from intrusion by cavalry pickets. By means of the telegraph line he put up to Mokattam Heights, interchanges of telegraph time signals have been made between that station and Greenwich, Suez, and Thebes. This expedition has now, therefore, nearly completed its work, and in a few days will probably break up."

Capt. Ord Brown, R.A. (Mokattam), Dec. 9:—

"The egress of Venus was observed at Mokattam this morning. There has been much bad weather and anxiety. All well now. Contact seen through very slight haze with [the] Lee [Equatorial] at about 13h. 25m. 25s. sidereal, and with De la Rue 13h. 22m. 21s. (Observe in the Greenwich book of observation with the model; my egress is always after other observers, except Mr. Gill's.) Clouds spoil much double image work, but many limbs

and cusps were taken. The phases closely resemble those of the model, except a line of light round the planet's edge, which appeared with strong sun just after the above contacts. It perplexed me and made me lose my best cusps. When I found that it continued two minutes and that it would be so indefinitely, I turned to cusps. I have exchanged bad telegraph signals twice with Thebes, and good ones three times with Suez.—Mokattam Country, lat.  $59^{\circ} 58' 14''$ .

Mr. Hunter (Suez) :—

"Sky cleared partly a few minutes before contact. Contact satisfactorily observed, and a considerable number of micrometer measurements made."

Capt. Abney (Thebes) :—

"Beautiful morning. Sun rather shaky at first, nice and sharp at time of contact, and good observations, though differing slightly in time. Sun pictures good. The fifty photographs in Janssen's slides include internal contact; external contact not taken. No black drop apparent in photographs after careful examination."

This, then, is all we know at present, or are likely to know for some little time, of the work done at purely Delisle stations. We now come to the stations at which the various methods of determining the least distance between the centres of the sun and Venus during the Transit, observed from different stations, are applicable.

And we may clear the ground by referring to the news from the southern stations first. From Hobart Town has come the best news in a telegram to the *Times* :—

"Prof. Harkness, of the American Transit Expedition at Hobart Town, reports, although the weather was bad, observations were particularly successful; 113 photographs were taken during the passage over the sun's disc."

We had previously heard of success from Melbourne and Adelaide; but these stations are not so well situated as Hobart Town, and it is doubtful if all the resources of a first-class fixed observatory, possessed by Mr. Ellery at Melbourne, will make up for his comparatively poor position.

We now come to that region where, in fact, the whole interest of the Transit has centred during the past week: to Asia and the adjacent Japanese Archipelago, neglected in the English arrangements even after the Board of Visitors of the Greenwich Observatory had very clearly indicated their opinion of the original official programme, by insisting upon the employment of the "method of curations" in the Southern Hemisphere. But, fortunately for the credit of English science, an English possession—India—has something to say in the Asiatic work. On the representation of Col. Tennant (who has done so much for astronomical science by his observations in India) of the importance of a station in the northern part of that country—a representation which was at once warmly received by the Viceroy—the Home Government at once took the matter up, and the result has been that a first-class observatory was erected at Roorkee. This was the Asiatic station from which news (which we chronicled last week) was first received.

But Northern and Eastern Asia was thickly studded with Russian, American, and French parties. In the Russian territory, Nertchinsk, Orianda, Charbarovka, Kiachta, Tschita, Port-Possiet, Wladiwostok, and many

other places that we might name, were strongly occupied, and the wealth of results, whether in photography or heliometric measures, has been marvellous. One of these places—Wladiwostok—was occupied by an American as well as a Russian party. Herr Struve's telegrams to the *Times* regarding the observations at these places are as follows :—

"*Wladiwostok*.—Transit of Venus observed at both contacts, numerous chords and distances of the two limbs were measured.

"*Port-Possiet*.—Much clouds and mist; two interior contacts observed, and thirty-eight photographs taken.

"*Charbarovka*.—First two contacts and some chords observed.

"*Tschita*.—Contacts observed, and four series of measurements with heliometer.

"*Orianda*.—Satisfactory observation of last two contacts.

"*Nertchinsk*.—Three contacts observed, and two diameters and twenty distances of the planet measured with heliometer.

"*Teheran*.—Full success of observations.

"*Thebes*.—Splendid weather; very important observations.

"*Kiachta*.—Much cloud; got only eight photographs.

"*Naratow*.—Clouds; complete failure.

"*Possiet*.—Photographs satisfactory after development, though taken through mist."

The work done by the American party at Wladiwostok, as stated in a Reuter telegram in the papers on the 11th, was as follows :—

"*Copenhagen*, Dec. 9.—Prof. Hall telegraphs from Wladiwostok to-day, at 10 A.M., that the observations of the Transit of Venus made at that place by the American party under his direction have not been very successful, on account of the hazy and cloudy weather. The first and second contacts were observed, and thirteen photographs were taken."

In Japan there were French parties under Dr. Janssen at Nagasaki and Kobe, an American party also at Nagasaki, and Russian and Austrian parties at Yokohama.

The telegrams giving the account of Janssen's work we must transcribe as they were received.

"*Nagasaki*, Dec. 9.—M. Dumas, Secretary Académie des Sciences and Minister Instruction, Paris.—Transit observed and contacts obtained. Fine telescopic images. No ligament. Venus seen over sun's corona. Photographs and plaques. Cloudy at intervals. Two members of our mission have made observations with success at Kobe."

"Transit observed at Nagasaki and Kobe. Interior contact, no ligament. Photographs revealed several clouds during transit. Venus seen over corona before contact. Gives demonstration of the existence of the coronal atmosphere."

The American party at Nagasaki has recorded its work in the following terms :—

"Day cloudy, but obtained second contact well—two observers; first and third contacts through clouds, and doubtful; 150 micrometric measures of cusps, separation of limbs, and diameter of Venus; thirty-one meridian transits both limbs, Sun and Venus; eighteen micrometric measures for difference of declination of limbs at meridian. About sixty good photographs. Ends threatening rain. Telegraph difference of longitude with Wladiwostok in November. All well."

The following is a copy of another telegram to the *New York Herald* :—

"*Wladiwostok, Siberia, Dec. 9 (10.10 M.E.)*.—Prof. Hall reports much haze and cloud at Wladiwostok. First and second contact of Venus observed, and thirteen photographs taken near middle of transit. A calm bay, with temperature  $34^{\circ}$ ; instruments and photographic apparatus working finely. All the American party working well."

The Russian and Austrian parties give no details; they only announce their success.

There is now a certainty that in the Southern Hemisphere the eastern stations will be more strongly occupied than the western ones. The Americans were foiled in their gallant attempt to occupy the Crozets, because they had not time to wait for weather moderate enough for them to land their instruments. The party has therefore gone on to Campbell Island, where they will already find a French party. It is difficult to restrain one's pen when we think of the combination of want of a true appreciation of the conditions of the problem, and want of that old spirit which used to make us take up posts of difficulty, which has prevented England being represented here. A successful Polar Expedition will scarcely wipe away the national disgrace which is ours in consequence of official action in this matter, and the French and Americans may well be proud of the position they now occupy.

The *Times* thus relates the French landing on Campbell Island :—

"A letter has been received to-day (Dec. 11), dated Campbell Island, Oct. 4, from the chief of the French Expedition stationed there. This had been carried to Bourbon by the ship which had transported the expedition to Campbell Island, and which left it to wait at Bourbon until the time came for fetching the astronomers away. The first idea was to keep this ship off the coast of Campbell Island in order that the observers might live on board; after struggling three days against horrible weather they at last landed on the island, and they soon perceived that it was impossible to keep the ship off the shore, which was without shelter and exposed to terrible gusts of wind, so that it ran the greatest risk of being lost. The members of the expedition, seeing that if the ship were to go down they were exposed to very serious danger—for they would be abandoned on an uninhabited island without means of communication, while everybody would think they still had the ship at their disposal—decided to unload the ship and establish themselves in the island and to send away the vessel, which would come and fetch them immediately after the observation of the phenomenon. This project was carried out. The observers began by organising temporary shelter, and then they built sheds to protect the instruments, the necessary utensils, and the provisions. The process of unloading was very long and troublesome, because the expedition, which has many members, had brought provisions for one year. While exploring the island they found nearly in the middle of the island a vessel which a hurricane had thrown there, and they were thinking of utilising the wreck, either by splitting it up or by placing themselves inside it, for protection against wind and weather. But two or three days afterwards another hurricane blew the ship out to sea, and they saw it no more. They were then obliged to do the best with all they had brought with them, for they were living in hourly dread of sharing the fate of the wreck.

"It is thought that since the 4th of October, the date on which the ship left for Bourbon, up to the moment of the transit, the expedition will have completed its organisation, its observatories, and have been able to fulfil its

mission. As soon as the ship reaches a telegraphic station, the expedition will hasten to communicate particulars to the Institute of France. Nothing is known, of course, as to the exact period when these communications will be received. The particulars relative to the difficulties of this expedition and the dangers to which it is exposed have been received here with all the more interest that it was feared only two days ago that the Campbell Island station would not be organised in such a way as to make the observations under favourable conditions. It is still feared the weather may not have been favourable, and that so much fatigue and effort may not have been rewarded with the magnificent result it deserves."

It will be seen not only that a large number of observations have been made bearing on the main point, but that many side issues of great interest are raised. Dr. Janssen's observations have decidedly been amongst the most remarkable, not only with regard to the absence of the ligament, but as touching the visibility of Venus on the coronal atmosphere. Any detailed reference to these and many other points we must, however, leave for a subsequent article. We have been anxious in the present one to put our readers in possession of the results of the observations, so far as we at present know them, in the most authentic and intelligible form.

#### CHAPPELL'S "HISTORY OF MUSIC"

*The History of Music.* Vol. I. From the Earliest Records to the Fall of the Roman Empire. By William Chappell, F.S.A. (London: Chappell and Co., 1874.)

MUSIC is now being cultivated in a much more earnest and thorough manner than heretofore, not only as a practical art, but as a matter of theoretical and historical interest, as is evidenced by the late formation of a "Society for the study of the Art and Science of Music," the object of which is to encourage musical studies of a higher character than those comprised in ordinary musical training. Hence, as the early history of music is one of the most interesting as well as one of the most obscure topics connected with the art, an authoritative new investigation like that before us is of real value.

Mr. Chappell, who has had much to do during his life with practical music, brought out some years ago a "History of the Ballad Literature and Popular Music of the Olden Time," a book which has become now of standard authority on such matters. It seems that the eminent historian Mr. Grote suggested to him that he would do well to carry his inquiries further back, and to attempt to unravel the state of music among the Greeks. His account of his progress is worth extracting. He says :—

"Mr. Grote's enthusiasm for the Greeks somewhat exceeded mine; and, although my recollection of the language was fresher than now, I did not suppose that, even if I should succeed, a knowledge of Greek art and science would greatly advance those of the moderns; therefore I received the proposal rather lukewarmly. But when favoured with the twelfth and last volume of the 'History of Greece,' with an inscription from the illustrious author, in deference to his long antecedent recommendation I took the first step forward, by buying the works of the Greek writers upon music.

"I had taken note of the odd uses of Greek words in manuscripts of the Middle Ages written in Latin; there-

fore, while reading the Greek authors on music, I continued to copy out such definitions of musical terms as I then encountered. I began without expectation of success as to understanding the music of the Greeks, owing to the number of able men whom it had baffled; but my little glossary seemed to afford the clue, and soon made me interested in the subject. It became evident that the Roman perversion of Greek musical terms had been one of the great difficulties in the way of previous inquirers (although by no means the only one), for I could then understand the system."

All this confirms the character of the author as an earnest, painstaking inquirer, and affords therefore a guarantee for the value of his historical investigations.

Mr. Chappell comments on the two great English musical histories of the last century by Burney and Hawkins, and contends that much of the obscurity in which they left the ancient music was caused by their obtaining their information second-hand, namely, from Boëthius and other commentators, chiefly Latin, on the Greek writers. Many of these had not sufficient knowledge of the subject to understand the original technical terms, which they therefore rendered either erroneously or obscurely, and thus error and obscurity have been introduced into succeeding writings.

"It may," says Mr. Chappell, "at first appear unaccountable that, among the numbers of learned men who made the attempt to understand the Greek system during so many ages, no one should have succeeded, especially considering that it would hereafter be shown, even to the quarter-tone, to be our modern system of music. So simple a result seems ludicrous. But this general failure is to be accounted for by the fact that the Romans had twisted round the meanings of the Greek words in so extraordinary a fashion that perhaps 'tone' and 'diatonic' are the only two which remain nearly identical in the two languages. So that, to unriddle the subject, the student had first to unlearn all that he had been taught as to the meanings of musical terms, and then to begin again, trusting only to the Greek authors. No Latin treatise would avail, nor would any modern language in which musical terms had been derived through the Latin, or through the Western Church. The misuse of Greek technical language by Romans was by no means limited to music."

To eliminate these errors, the author tells us, and we believe him, that he has in every case, where possible, gone to the fountain head, and that the information he gives us may consequently be depended on.

We have thought it right to show at some length what are the author's qualifications for his work, and on what grounds he lays claim to our attention and credence; for, in *historical* works this is all-important; few of us have opportunity, and still fewer have inclination, to grope for ourselves among the mouldy lore of antiquity; we are glad enough to find others who will do it for us, and are ever ready to take as authentic whatever they tell us they have found there. Hence correctness and care are cardinal virtues in historical works; the want of these qualities renders such works worse than valueless, as merely promoting the dissemination of error.

The history of music, interesting as it is, is not, properly speaking, a subject to be treated of largely in NATURE; but, in justice to the meritorious author, we may venture to mention some of the results of his labours.

In the first place, he shows that the system of music

used by the Greeks did not originate with them, but was borrowed from more ancient nations. He finds, for example, that "the number of notes in the Egyptian scale was precisely the same as the Greek, including the three Greek scales, diatonic, enharmonic, and chromatic." No Greek writer alludes to any difference between the Egyptian and Greek systems of music, although the best Greek works on the science of music, saving the *Problems of Aristotle*, were written on the soil of Egypt." Then he turns to the Chaldeans, or learned men of Babylon, and again finds (through an astronomical comment which, as usual, supposes the motion of the planets to be regulated by musical intervals, and thus to make everlasting harmony) that the Chaldeans had the same musical intervals of fourth, fifth, and octave, as the Egyptians. From these he was led to Hebrew music; remarking that proofs are not wanting of the similarity of this to the music of surrounding nations; so that "henceforth we may fairly conclude that we have at last arrived at the musical system of ancient Asia, and that it is our A, B, C, D, E, F, G."

The author, of course, enters largely into the progress of music in Greece. We read of the early tetra chord lyre, of its enlargement by Terpander; of the great improvements made by Pythagoras in the addition of the octave, the fifth, and other notes; of his important determination of the proportions of the lengths of strings, subsequently transmitted to posterity by the great geometer Euclid; of the chromatic and enharmonic scales, hitherto so perplexing; of the improvements in certain harmonic ratios made by Didymus and Ptolemy, and so on; from all which we undoubtedly gather a far clearer view of what Greek music was than can be obtained from either of our English histories.

The result is that the ancients anticipated almost exactly the diatonic scale of modern times. Their scale passed over to the Latins; it was adopted without change by the early Church; and by this means it has come down, unaltered, to our time. If we run up two octaves on the *white* keys of the modern piano, beginning and ending with A, we are playing the same notes as the Greeks used, any time after Pythagoras. We may add that if we use only the *black* keys (and many modern tunes may be thus played), we sound a scale precisely corresponding to one of the Greek "chromatic" genera.

The scale, be it remembered, is the *material* from which music is made. To discover what sort of melodies the ancients constructed from this material is another thing. Mr. Chappell has, however, presented us with three real Greek tunes, set to hymns to Calliope, Apollo, and Nemesis respectively. They have been, it is true, decked out, by the skillful aid of Mr. Macfarren, in an anachronous dress of modern harmony and rhythm, suggesting the idea of Pythagoras in a periwig; but, at any rate, they are no more incongruous in this respect than the so-called "Gregorian" chants, as sung with modern embellishments at a Ritualistic church-service.

The question has been often and warmly discussed whether the ancients used what we call harmony, or whether they did anything analogous to our singing or playing in several parts. Our author believes that they did, but in this matter he has not the argument all his own way. The late M. Fétis, who devoted the last

years of his life to the preparation of a great History of Music,\* has made a most elaborate investigation of this point, partly in the third volume of his work, and still more fully in a separate memoir published by the Academy of Sciences of Brussels. It is ably and forcibly argued, in opposition to many learned German critics who have held Mr. Chappell's view, and M. Fétis arrives at the conviction that "the supposition of the existence of harmony among ancient nations is one of the most remarkable extravagances of modern times." Mr. Chappell is very positive in his own opinion, but when we come to compare the two essays we cannot help seeing what a poor match his desultory guerilla argumentation is for the powerful disciplined logic of his more experienced antagonist, and cannot hesitate for a moment which side should prevail.

But even if we were inclined to believe with our author that the ancient Greeks did use some sort of harmony (other than the octave, which M. Fétis freely allows them in common with all nations), we are not much the forwarder: for even Mr. Chappell appears quite at a loss to form any reasonable idea of what this harmony was like. After all, therefore, the dispute is little more than "twixt tweedle-dum and tweedle-dee."

The subject of ancient musical instruments is as important and as interesting as that of the music itself: and, indeed, they have in all ages had such a necessary connection, and have been so dependent on each other, that improvement in one has gone hand in hand with improvement in the other.

Mr. Chappell has devoted much attention to the evidence as to the nature of the instruments used in ancient times. This, he says, has always been found a difficult subject to treat upon, partly because so few of the instruments named by classical writers can be identified by pictorial or written descriptions, and partly because such descriptions, when they do exist, are often obscure or contradictory, particularly when obtained only through the medium of incorrect translations. He goes through a long list of ancient instruments of the three classes—wind, percussion, and string—and has given a large fund of information about them.

But what he prides himself most upon is the elucidation of the construction of the hydraulic organ, about which there has hitherto been much doubt and difficulty. He shows that this has arisen either from misapprehension of the ancient descriptions or from a want of sufficient knowledge of mechanism to understand the technical details; and he gives, in a most interesting chapter, an account of the instrument, which evidently presents a high claim to be the true one. In this particular we are delighted to award him the merit of a real triumph over his enemy, M. Fétis, who says, after speaking of the ambiguity of the description of the instrument left by Vitruvius:

"Sous ce rapport l'incertitude persiste, et tout porte à croire qu'elle ne sera jamais dissipée, à moins que le hasard ne fasse découvrir un des instruments du mécanicien d'Alexandrie, dans les recherches faites à Pompéii."

\* "Histoire générale de la Musique, depuis les temps les plus anciens jusqu'à nos jours." Par F. J. Fétis. Paris: Firmin Didot. Four volumes of this are now ready, bringing the history down to somewhat later than the time of Guido d'Arezzo; and, we understand, materials have been left for still more.

If it were only for his solution of this difficulty, Mr. Chappell's work deserves high praise.

We cannot expect every historian to be a Gibbon or a Hume, and though we readily testify to the merits of Mr. Chappell's work, we are obliged to say it is not without its faults. One is the tendency of the author to be diffuse and discursive in his style, to such an extent, indeed, as to give the work the character rather of an amusing gossip than of a serious history.

Another of Mr. Chappell's peculiarities is his strong tendency to over-confident dogmatic assertion, which renders it often difficult for the reader to distinguish between statements he has evidence for, and mere opinions of his own. Every writer on history should remember that on that subject dogmatism is utterly out of place: no man's *ipse dixit* is worth the paper it is written on: if he cannot or will not show chapter and verse for all he has to say, he had better let history alone. Hypotheses and speculations on obscure points are all very well; they are often useful for discussion, and sometimes turn out right; but they must be put forward clearly as what they are, and not given as truths.

Mr. Chappell has a high opinion of his own qualifications for his work, which is quite pardonable; but this is unfortunately coupled with an unduly low estimate of the competency of other historians, which is not pardonable. His contemptuous sneers at M. Fétis, for example, are in the worst taste; and if the Nestor of musical literature were alive to reply, we would not be in Mr. Chappell's shoes for a trifle. As it is, did it never occur to him that, as M. Fétis's history has now a wide circulation, and is becoming, in fact, the European standard book on the subject, readers who have access to both works might be tempted to retaliate by comparisons not altogether in favour of the English historian? These who live in glass houses should not throw stones.

We have alluded above to an anachronism in the form in which Mr. Chappell has presented some of the Greek tunes. There are other analogous cases where he produces confusion by ascribing to the ancients ideas that have only arisen in modern times. He talks, for instance, often of the *key* and the *key-note* of Greek music. Does he mean to assert that any ideas existed in those days analogous to what we understand by these terms now? And when he sees, in an ancient picture, a man shown clapping his hands, he calls him a "conductor beating time." Had Sir Michael Costa really a prototype among the Egyptians, who gesticulated four in a bar?

We wish we had no worse faults to find than these, which are, after all, only peculiarities of style (and *le style c'est l'homme*); but unfortunately there is one part of the work which, as it affects the interests which it is the peculiar object of NATURE to promote, we are bound, though most reluctantly, to speak strongly on. The followers of Zoaroaster hold that every man is subject to the alternate influence of two spiritual agencies, one prompting him to good, the other inciting him to evil. Ormuzd (we think that is the name) has been active with Mr. Chappell, leading him through the pleasant pages of Aristotle and Plato, and dictating to him all the agreeable matter in which we have been delighting, while the serpent-like Ahriman has been looking grimly on. But, the



history ended, the turn of the evil tempter has arrived, and the good angel has retired, veiling his face with his wing, and dropping (if angels can weep) a tear over the calamity which he had no longer power to avert.

In plain language, Mr. Chappell has been minded, in an evil hour, to wander away from his legitimate domain of Ancient History, and to indite a long disquisition on the by no means kindred subject of Modern Science, treating especially on the laws and phenomena of acoustics, and their bearing on the nature and relations of musical sounds. In this his aggressive spirit is again manifested. All scientific men interested in the theory of music know that within the last few years Prof. Helmholtz, of Heidelberg, one of the first physicists of Europe, has brought out a work, "Die Lehre von den Tonempfindungen, als Physiologische Grundlage für die Theorie der Musik," which, for the profundity of its knowledge both of the physical and musical elements of the question; for the novelty and importance of its views; for the skill and conclusiveness of its experimental demonstrations; and for its general masterly style, has deservedly excited the admiration of all Europe. It has gone through three editions in Germany, has been also published in French, is now being translated into English, and has served as the basis already of several other English works, the author of one of which describes it as "a profound and exhaustive treatise, which does for acoustics what the Principia of Newton did for astronomy." Now, Mr. Chappell presumes to criticise this work in a tone which clearly shows not only that he is unaware of the reputation of its author, but that he is under some strange hallucination as to his own qualifications for setting up as judge in the matter. He attributes to Helmholtz both theoretical ignorance and experimental error; puts forward his own confused notions as "the true (in offensive opposition to Helmholtz's false) physiological basis for the science of music;" and sums up with the following paragraph, which, comparing the scientific position of the two writers, may certainly be considered a curiosity of criticism:—

"I am persuaded that the *Tonempfindungen* is a hasty book . . . the value of time was too largely considered in its composition, and some very necessary experiments, such as those upon harmonics, were omitted. But since success has been so widely attained, it may be hoped that the author will find time to revise the next edition, and, in doing so, that he will bear in mind an admirable motto for men of science, *Chi va sano, va piano.*"

A HASTY BOOK!—why, its very first sentence states that it is the result of *eight years' labour!* Experiments on harmonics omitted!—why, they form the substance of the entire book, from beginning to end! From these, and many other misapprehensions of Mr. Chappell's, we are led to doubt whether he can even have read the great work he ventures so freely to criticise.

Prof. Helmholtz has always maintained cordial relations with this country, and in the name of English science we think we owe him an apology that anything like this should have appeared in our language under a quasi-scientific guise. He will, however, know that historians may rush in where philosophers would fear to tread, and we need hardly assure him that no English scientific

man, competent to judge of his work, would be in the least likely to endorse Mr. Chappell's criticisms.

We lament Mr. Chappell's mistake on another ground. Practical musicians have generally but little knowledge of the scientific data on which their art depends; such information is never taught in England to professional students as any part of their musical education; it is studied almost exclusively by men of science and amateurs. All right-minded persons would gladly desire to promote the wider spread of knowledge of this kind; but we cannot but feel that when a practical musician takes it into his head to attack scientific authorities who are universally respected, and scientific doctrines which are universally established, a great obstacle is thrown in the way of that cordial sympathy and co-operation which ought to exist between the two classes. On the one hand, the scientific man will be angry at the perverse unteachableness of the musician; while, on the other hand, the musician, who may easily mistake error for truth, will be set against the theorist and be more disinclined than ever to receive information from him.

It would be an ungracious task to point out in detail Mr. Chappell's errors; we would rather recommend him, instead of waiting for Prof. Helmholtz to "revise his next edition," to read the work as it is, more thoroughly and carefully, and with more respect for the character of its author. And in the meantime, out of sincere good will, we earnestly advise him to expunge all this irrelevant matter; it not only damages his valuable book, but, what is worse for him, it tends to engender in the minds of the best class of readers a want of confidence in his judgment and accuracy as regards other things.

FOSTER AND BALFOUR'S "EMBRYOLOGY"  
*The Elements of Embryology.* By M. Foster, M.A., F.R.S. and Francis M. Balfour, B.A. Part I. (London: Macmillan and Co., 1874.)

STEP by step the simple two-layered blastoderm [of the hen's egg] is converted into the complicated organism of the chick." The separate cells of which it is originally composed have, to all appearances, the most uncomplicated relations one to another; nevertheless, in accordance with laws of which we have not the least conception, under the influence of slight external warmth, by a series of fissures, inflections, and developments in special directions, they convert the store of albuminous material that, together with them, is included within the egg-shell, into an organism so elaborate as a fully developed bird, which can run about and feed itself immediately it makes its appearance in the theatre of active life. The physicist, thoroughly acquainted as he may be with all the principles of statics, dynamics, heat, light, and electricity, finds himself quite at a loss to explain or to predict any single one of the numerous changes which have taken or will take place in this blastodermic membrane during any period, however short, that it has been the subject of observation. Neither the chemist nor the physiologist will find himself in any more advantageous position, except that the latter, from previous experience, will be able to state dogmatically the succession of the steps of the developmental process. We group these phenomena, apparently so extra-physical, under the term



"vital"; and if at any time it should be shown, which is well within the region of possibility, that they depend on the manifestation of a force other than one of those with which we are at present acquainted, the disciples of the "vitalistic" school will have reason to exult over those "physicists" who do not admit the existence of any yet undiscovered mode of motion. As yet, the fact that one's parents in their earliest days went through the same changes as oneself is not considered a sufficient basis for any logical hypothesis on the subject of the progressive development of one's constituent elements.

Again, since the time of Von Baer, the marvellous parallelism which is so continually observed between the various development-stages of living beings considerably removed from one another in the scale of zoological affinity, has made the study of embryology an essential part of the science of Comparative Anatomy; in other words, the whole life-history of the individual, and not only the period of maturity, is now known to be necessary for our accurate comprehension of the pedigree of the animal kingdom, in the same way that it may be considered to reflect it. This conception has of late borne fruit in the all-embracing hypotheses of Prof. Hæckel and Mr. E. Ray Lankester, as well as in the new classification of the animal kingdom so recently promulgated at a meeting of the Linnean Society by Prof. Huxley (NATURE, vol. xi. p. 101). It may, however, be mentioned that there is a limit to generalisation in this direction; for the theory of natural selection allows us to assume that some of the forces which come into play to produce variation in the individual, and therefore generally, may do so at the very outset of embryonic life; and, if they do so, differences from the ancestral type may then appear in all the embryonic stages from the commencement. Such a view of the question helps to explain otherwise most involved subjects, such as the existence of "gastrea" of two entirely different types; the development of the notochord from different layers of the blastoderm in different groups of animals; and other varying features of early embryonic life.

These remarks all indicate how large a field is opened up for the student of every branch of natural science by the study of embryology; and it is evident that before any considerable progress can be made in any of the many intricate problems involved, a minute acquaintance with the fundamental facts of development is indispensable. The work before us is the first systematic attempt which has been made, in this country at least, to place the whole subject on the required footing; and in how satisfactory a manner this has been accomplished will be attested by all who have taken the opportunity of studying it. When supplemented by the other two volumes promised by the authors in their preface, it will form a complete history of the most important changes known to occur during the embryonic life of the different groups comprising the animal kingdom. For a long time past such a work has been a great desideratum. The monographs of different authors are scattered over a whole library of books; many who require to employ the known results have but little time to investigate each sufficiently to form a sound opinion of their own, and fewer still are able to prosecute the somewhat special line of investigations on their own account. All working biologists,

therefore, owe much to Dr. Foster and Mr. Balfour for the great care they have taken to sift the literature of the subject, as well as for their independent investigations, which add so considerably to our knowledge of a branch of biology which has but little attracted the attention of our own countrymen.

To turn to the subject-matter of the work itself. There are advantages possessed by the hen's egg, found in no other vertebrate embryo, which have led the authors to take the *history of the chick* as the starting-point for their subsequent descriptions. It is "the animal which has been most studied, and the study of which is easiest and most fruitful for the beginner." This must be evident to anyone who has had the least experience. A chronological order is followed, in which the changes which occur day by day, and sometimes even hour by hour, are fully traced through the earlier days of incubation; the incidents of the later days being much more briefly summarised, because they pertain more to the bird as a bird, than to it as a member of the sub-kingdom Vertebrata.

As above remarked, but little of the embryological work which has been undertaken since the time of the illustrious Harvey has been conducted in this country; it is therefore not to be wondered at that we are far behind the times regarding it. Many important points which for some time past have been familiar to foreign investigators, mostly German, are not sufficiently laid stress on, or are omitted altogether, in our physiological treatises and textbooks. Among these may be mentioned the evanescent nature of the "primary groove" in the mesoblastic layer of the blastoderm, and its replacement by the "medullary groove," from which alone, and not from the former, the spinal canal is subsequently formed. "The primary groove, then, is a structure which appears early, and soon disappears without entering directly into the formation of any part of the future animal. Apparently it has no function whatever. We can only suppose that it is a rudiment of some ancestral feature," remark our authors.

The much-debated subject of the development of the blood-vessels and corpuscles is entered into in detail, and fresh investigations by one of the authors are recorded, which agree in many respects, as they remark, with those of Remak and Klein. The vessels are shown to be formed by the union of processes sent out from the mesoblast cells of the pellucid area. The nuclei of these cells enlarge and break up into numerous small ones, the majority of which acquire a red colour, and become converted into blood-corpuscles; whilst the rest, changing into a spindle-shaped form, develop into the synovial lining of the blood-vessels.

Another point of special interest is the development of the permanent vertebral column. As all know, the protovertebræ are developed at the sides of the notochord, with a neural arch attached mainly to the posterior end of each; whilst the root of a spinal nerve occupies the anterior portion. "On the fourth day the transparent lines marking the fore and aft limits of the protovertebræ are still distinctly visible. On the fifth day, however, they disappear, so that the whole vertebral column becomes fused into a homogeneous mass whose division into vertebræ is only indicated by the series of ganglia. This fusion . . . is quickly followed by a fresh segmentation, the resulting segments being the rudiments of the

*permanent* vertebrae. The new segmentation, however, does not follow the lines of the earlier division, but passes between the ganglionic and the vertebral portions, in fact, through the middle of each protovertebra. In consequence, each spinal ganglion and nerve ceases to form the front portion of the primary vertebra formed out of the same protovertebra as itself, but is attached to the hind part of the permanent vertebra immediately preceding. Similarly, the rudiment of each vertebral arch covering in the neural tube, no longer springs from the hind part of the protovertebra from which it is an outgrowth, but forms the front part of the permanent vertebra, to which it henceforward belongs. . . . By these changes this remarkable result is brought about, that each permanent vertebra is formed out of portions of two consecutive protovertebrae."

Such being the case, the question suggests itself as to what becomes of the portion of the new column corresponding to the anterior or cephalic end of the protovertebra nearest the skull which has no other semivertebra wherewith to blend. It has no neural arch, and does not enter into the formation of the cranium, for the protovertebra does not enter that complicated structure. We are not informed as to its destination. May it not be that it persists as the odontoid process of the axis, which, from not being able to maintain an independent existence, joins, late as we know, the second cervical vertebra? This hypothesis involves a difficulty, no doubt, as to the nature of the atlas, but seems to throw some light on the peculiarity in the conformation of the axis.

The development of the vascular system, through the various complex stages, is most fully explained, with the assistance of several very instructive diagrams. We can hardly help having a feeling of regret that the common fowl does not resemble its allies, the Mound-makers (*Megapodidae*), in having only a single carotid artery instead of two, because then we should have the question answered as to the method by which the companion vessel is lost, which is at present not in the least understood.

We must refer our readers to the work itself for an account of points so important as the development of the Wolffian bodies and their ducts, the spinal cord, the heart, the nasal pits, as well as the many other details respecting the different organs which go to form the adult bird; original observations will be found on most; and where these are absent, the excellence of the *résumé* of the work of others will clearly prove with what conscientious care the authors are carrying out the evidently pleasurable labour they have imposed upon themselves. As far as the permanent kidneys are concerned, it must be mentioned that, from their manner of development, it is shown that their separation morphologically from the Wolffian bodies is an occurrence of *purely secondary importance*.

Now that we have a text-book of embryology produced under such favourable auspices, it is to be hoped that the far-spread ignorance on that subject, which is at present but too apparent on all sides, will no longer exist, and that a higher standard whereon to commence further investigation will quickly develop itself amongst all English students of biology.

## OUR BOOK SHELF

*A Monograph of the Post-tertiary Entomostraca of Scotland.* By G. S. Brady, H. W. Crosskey, and D. Robertson. (Palæontographical Society.)

In this part of its publications the Palæontographical Society has done good service to that large body of geologists who take interest in the story of the old glaciers and icebergs of Britain and love to gather when they can the traces of the life which peopled the frigid sea once spread over some of the richest tracts of our present islands. The descriptions here given of the localities and sections of the glacial deposits are perhaps all that could be at present attempted, but they offer a very puzzling problem to the reader who would fain know something of the chronology of the deposits. Nothing can show more satisfactorily the labour which has in recent years been bestowed upon these Post-tertiary clays than the fact that a few years ago not one of the minuter forms of Crustacean life had been noted as occurring in them, while now more than 130 species belonging to twenty-seven genera of Entomostraca have been carefully examined and described by the authors of this Monograph. The names of Brady and Robertson are a sufficient guarantee for the faithfulness of these descriptions, while Mr. Crosskey's knowledge of the localities and his expertness as a collector have given an additional fulness and value to the Monograph. Though but dry reading for ordinary people, these pages, with their accompanying admirably executed plates, will be a valuable boon to many a student of Post-tertiary geology.

*The Races of Mankind: being a Popular Description of the Characteristics, Manners, and Customs of the Principal Varieties of the Human Family.* By Robert Brown, M.A., &c. Vol. II. (London: Cassell, Petter, and Galpin. *No date*.)

THIS work, which seemed in the first volume to promise some scientific value, is now down to the level of the popular picture-book. There are some good pictures in it, and no doubt the boys and girls who have it given them will pick up ideas from its compiled information. We have not done more than look into it here and there, finding errors small and great. At p. 4, a Spanish-American is called, with curious felicity of blundering, "Don Jose Marie del Muchos Dolores." At p. 22 we read, "The smallest shopkeeper in Germany expects to be addressed as Mr. Court-Councillor." At p. 284 is a picture of a Bushman playing on the goura, or musical bow. This appears to be an altered copy of the illustration in Mr. J. G. Wood's "Natural History of Man," vol. i. p. 295; but whereas Mr. Wood's artist knew that Bushmen have narrow heads, and drew his accordingly, the present draughtsman, by his alteration, has given his native a skull of enormous width. At p. 113, in contradiction to the weight of ethnological evidence, the Australians and Tasmanians are treated as belonging to the same race. When we add that many of the illustrations are taken without acknowledgment from Figuier's "Human Races," it is not necessary to inquire further where M. Figuier got them.

## LETTERS TO THE EDITOR

[The Editor does not hold himself responsible for opinions expressed by his correspondents. Neither can he undertake to return, or to correspond with the writers of, rejected manuscripts. No notice is taken of anonymous communications.]

The Royal Agricultural Society and the Potato Disease

My main object in writing to you was to correct what Mr. Jenkins admits were "grotesque statements," and to claim for a distinguished English botanist credit for work done by him thirty years ago, which I was unwilling, without protest, to see assigned to anyone else.

No doubt the Royal Agricultural Society was not founded for the advancement of science in general or of botany in particular. When, however, it transcends the practical limits it has imposed upon itself, and promotes a purely scientific investigation, the way it sets about it is, I suppose, a fair object of criticism in a scientific journal.

Mr. Jenkins complains that I have not taken the trouble to read the official reports published by the Society, and thinks my criticisms upon them might have had some value. As a matter of fact I have done so, and my difficulty is to be quite sure that I understand what the last and most important really means. To say nothing of the occurrence of "jonidia" for "conidia," I find the following sentence:—"Prof. de Bary expresses sanguine hopes that he has at last discovered the certain nidus (*sic*) or resting-places of the oospores or active primary germs of the fungus." It would not have occurred to me to describe oospores—in other words, resting-spores—as *active*, and it has been suggested to me as not impossible that oospore may also be a misprint in place of zoospore. There is the more necessity for caution in the matter, as the publications of the Royal Agricultural Society do not seem to receive the botanical revision that might have been expected. Only last year—and it was not a solitary blunder—a fungus was figured in the Society's Journal as *Aspergillum (sic)*, which was obviously no *Aspergillus* at all, but the common Bread-mould (*Ascochloa Mucedo*). No doubt, in due course, we shall have the opportunity of reading, at full length, what Prof. de Bary has added to our knowledge of the matter; but in the meantime we should not forget what is due to those who have already worked at the subject in this country.

Mr. Jenkins denies that the Society offered prizes for disease-proof potatoes. I find that in the report of the judges on the abortive essay competition, presented to the Council, Dec. 10, 1873, it was recommended, "That valuable prizes be offered for (a) The best disease-proof early potato; (b) The best disease-proof late potato." Again, the recently published official report to which I have already referred commences: "The judges appointed to inspect the growth of the six varieties of potatoes, which were entered for competition as disease-proof," &c. It may be that this is "colloquial" language, and does not mean what it says; but Mr. Jenkins must know that if by any chance any one of the potatoes tried had run the gauntlet of the three years' trial, it would have been advertised far and wide as stamped with a "disease-proof" character by the Royal Agricultural Society.

Mr. Jenkins complains that I suggest an offensive spirit as actuating the Society in its communications with Prof. de Bary. I can only say that I used the Society's own language. I find that the judges, in their report, after declining to recommend any one of the ninety-four essayists for a prize, propose "That a sum of money (say 100*l.*) be granted for the purpose of inducing a competent mycologist to undertake the investigation of the life-history of the potato-fungus" (as if nothing had been done in it already). The joint Botanical and Journal Committee thereupon gave notice that they would ask for a grant of 100*l.* to carry out this recommendation. I am not aware that the British Association proceeds in this way in distributing its funds, and I leave Mr. Jenkins to reconcile what I have quoted with his statement, "that the first step taken by the Council of the Society was to direct me to write to Prof. de Bary."

Let me sum up the substance of my criticisms. The potato disease has been before the scientific world for thirty years, and has been investigated by Berkeley in England, Montagne and others in France, De Bary in Germany. The Royal Agricultural Society takes charge of a competition which induces ninety-four persons to write on a subject on which it was *a priori* in the last degree improbable that they could have any really important unpublished facts to bring forward within the limits of even the extended time at which the essays were to be sent in. On the failure of this scheme prizes are offered for disease-proof potatoes, "disease-proof" being subsequently defined to mean immunity from disease in twenty different districts for three years. Were a disease-proof potato a probable thing, it might clearly be trusted to establish its own reputation. Lastly, the amateur world of prize essayists having proved fruitless, the cryptogamic botanists of this country—many of them men of European fame, who would doubtless have willingly responded to an appeal from the Council to co-operate in the matter—are passed over *en bloc*, and the matter is placed in the hands of a German scientific man—highly and worthily distinguished, doubtless—but who, I am convinced, would be far from approving the slight placed on our countrymen, one of whom has accomplished

what will ever be a classical research in this very subject. I submit that when I applied the expressions "spasmodic," "ill-considered," and "wanting in scientific method" to these proceedings, I was not using inappropriate language.

W. T. THISELTON DYER

### Sensitive Flames

PERMIT me to thank Prof. Herschel for his all too kind acknowledgment of the aid my former brief communication to NATURE may have been to him. In a paper on Sensitive Flames that is awaiting the needful leisure to complete, I have given a brief history of this subject—which, by the way, so far as regards the discovery of sensitive flames, Prof. Herschel has partly misapprehended, though there can be no doubt the valuable letters of Prof. Herschel will play an important part in the development of these phenomena. I am glad to find that, so far as Prof. Herschel has recorded his views, they corroborate the results of my own experiments (begun as long ago as 1867) in search of the cause of the sensitiveness of various fluid jets, and the application of sensitive flames to acoustic investigation and other practical ends. For reasons, into which I will not enter here, I was led to postpone this inquiry, and it is only comparatively lately that it has been resumed.

The keynote to the whole of the phenomena is, I believe, to be found in Savart's beautiful investigations on liquid jets. Any fluid body, gaseous as well as liquid, escaping from an orifice in a tranquil stream, consists of a continuous and a discontinuous region, and is subject to the play of opposing forces which excite pulsations in the jet, the number of which is directly proportional to the velocity of the issuing stream, and inversely as the diameter of the orifice. When a note is sounded approximately in unison with the vibration number of these pulsations, the jet of water, smoke, or flame is thrown into more vigorous vibration, and a strained condition of the jet is set up.

Hence it is easy to obtain a series of sensitive flames, issuing from orifices of decreasing size, capable of responding (within a certain range) to the successive notes of the gamut; the higher notes affecting, of course, those flames from the smaller orifices, and which also require to be under greater pressure of gas than the flames responding to the lower notes. The relative rate of vibration of these flames is at once clearly seen by viewing them together in a moving mirror. But I will not weary your readers by further entering upon a subject with which already they must be somewhat tired.

W. F. BARRETT

Royal College of Science, Dublin, Nov. 30

### Fossils in "Trap"

I AM much obliged by your insertion of my letter on "Fossils in Trap." You are right in supposing that the trap I referred to was crystalline augitic trap. If it had been tufa I should not have written to you as I did, as I was well aware that fossils in tufa were of common occurrence. Shortly after I wrote I found that the *Favosites gothlandica* which shows the section is still imbedded in a portion of the slate, which is olive-coloured, and closely resembling the trap. This is so intimately connected with the trap that it is impossible to trace a line of connection.

Halifax, Nova Scotia, Nov. 14

D. HONEYMAN

[Dr. Honeyman's discovery would appear to resolve itself into the simple fact that his "trap-dyke" has involved in its mass fragments of the fossiliferous strata through which the molten rock has risen—a fact, we presume, with which every practical geologist who has worked amongst igneous rocks must be more or less familiar.—E.J.]

### THE RELATION OF RACE TO SPECIES

IN a notice of Quetelet's works, published in NATURE, vol. v. p. 358, I raised the question whether this eminent statistician's method of defining a race or population might be applied to provide naturalists with a means of defining species. Since then, the consideration of Mr. Francis Galton's explanatory diagram, given at p. 28 of his work on "Hereditary Genius," has led me to attempt to carry this problem a stage further.

Instead of using, with Quetelet, a binomial curve to show the constitution of a race, with its central type and varieties, Mr. Galton sets before our minds the very indi-

viduals who compose the mass, each one being represented by a dot. His diagram, adapted in (a) of the present figure, stands for a population descended from a common ancestral stock, the individuals congregating most closely about the place of the central type or standard individual, and gradually decreasing in numbers as they become more different from that type or standard. In this graphic representation, the race can, of course, only be arranged in order as to some one quality. In the particular case for which Mr. Galton uses it, this quality is stature. The individuals of the mean or average height (say, 5 ft. 8 in.) are shown as most crowded, while the taller and shorter men become fewer and fewer as their stature becomes more unusual, till at last we come to one or two outlying giants and dwarfs, beyond whom no more individuals exist. Here, then, is set before us the distinctest idea of a race, both as to its type and as to its limits of variation on either side. I now proceed to apply the method of this diagram to a more complex state of things.

In nature we habitually find races blending into one another. Our own species shows this perfectly, when mixed breeds are considered. Let a population partly of Europeans and partly of negroes be placed on a West Indian island. These two races being classified according to colour, a few of the darkest Europeans would be seen

to make some slight approach towards a few of the lightest negroes; but there would be no individual of either race who could be mistaken for one of the other. They would, therefore, at the outset be represented by two such groups of dots as (a), with a blank space between. But as soon as the first generation of mulattoes come into existence the case will be altered. An intermediate race has arisen with its definite central type, and its variants now coming much closer to the whites on one side and to the blacks on the other. In the next generation there will be quadroons and sambos (cross between negro and mulatto, Spanish *zambo*). Now the fusion will be so complete, that of many individuals it will hardly be possible to say whether they are quadroon or mulatto, while in the same way others may be either mulatto or sambo, or either sambo or negro. One or two more generations would still further obliterate the distinction between adjoining varieties, but for convenience sake the figure (b), showing the blended races, is taken only in the second generation. In this way the whole human species, or any species of plants or animals, may be ideally classified into its various races, either in fact blending into one another, or capable of so blending by intercrossing. A species thus classified into its component races is shown either in (b) or the central part of (c).

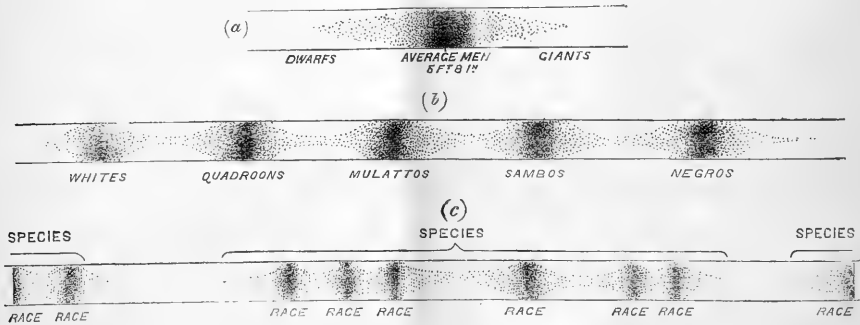

Let us now attend to the effect of variation, artificial or natural. Starting with a single race, this may in the course of time and circumstance develop within itself a number of varieties or races. Nor, if variation is promoted either under domestication or by various conditions of life acting for a long series of generations, is there any difficulty in conceiving two adjacent varieties to recede from one another and the intermediate individuals to die out, till a wide gap is left between the two races. At first this gap, though real, would be capable of being at any time bridged over by cross-breeding, and thus would only be a temporary break. But as variation went on, a critical period would at last be reached, when individuals from the two sides could no longer produce fertile offspring. Then a separation of one species into two would have taken place. This change is illustrated in (c), where the extreme forms of two adjacent species are seen to the right and left, still perceptibly near the extremes of the original species from which they have parted, but never to be joined to it again unless by a process of backward variation most unlikely to happen across any width of interval. This ideal representation was at first intended rather to show the actual distribution of animals in existing species than to involve a hypothesis as to how these species originated. But, after consulting Mr. T. R. Stebbing, I see the desirableness of making the diagram express both facts and hypothesis, leaving those who will to take them

apart. The whole figure, as it stands, contains an ideal of evolution or development from a single race of animals at (a), into a species made up of several races at (b), and thence into any number of separate species at (c).

EDWARD B. TYLOR

#### TRANSIT OF VENUS

Colonel Tennant's Station at Roorkee, India.

THE full and very able account of the preparations for observing the Transit of Venus drawn up by Prof. Forbes and published in these columns do not include those which have been made by the Government of India under the authority of the Secretary of State in Council. When Prof. Forbes wrote, these were not sufficiently advanced to admit of description. Now that they are completed it is desirable that an account of them should be made public.

At an early period Col. J. F. Tennant, R.E., F.R.S., brought the subject before the Viceroy in India, and proposed the organisation of a station in the north-west, near Roorkee, well known as the seat of the great Civil Engineering College. The Viceroy heartily responded to the suggestion, and communicated his views to the Home Government.

Some time was unfortunately lost in official correspond-

ence, and it was not until July 1873 that I received final authority to order the necessary instruments. With the sanction of the Secretary of State, I conferred with Mr. Warren De la Rue on the subject, and am indebted to that gentleman's zeal and experience for a great deal of valuable assistance.

The following is a list of instruments prepared by Mr. De la Rue and myself, and sanctioned by Government:—

- 1 Photoheliograph.
- 1 Equatorial.
- 1 Altazimuth.
- 1 Transit Instrument.
- 1 Chronograph.
- 1 Standard Clock.
- 3 Journeyman Clocks.

I will briefly describe each of these.

*Photoheliograph.*—This is of the same identical size and construction as those supplied to the stations equipped under the auspices of the Astronomer Royal. It is well known that these have been constructed from the designs of Mr. De la Rue and under his close personal supervision. I therefore advised that that gentleman, as the first authority on the subject, should be requested to superintend the provision of this particular instrument, and that he should have *carte blanche* for the introduction of any improvements or additions suggested by his constantly enlarging experience. My recommendation was adopted, and I need hardly say that Mr. De la Rue, with his usual public spirit, at once gave his services to the Government and to science. This instrument, like its prototypes, was made by Mr. Dallmeyer. Janssen's apparatus, modified by Mr. De la Rue, for multiplying the photograms, has been supplied to this instrument.

*Equatorial.*—This has an object-glass of six inches clear aperture. It was made by Messrs. Cooke and Sons, of York, and is generally of the form which those artists have made familiar to the astronomical world. It is a universal instrument, being capable of adjustment for any latitude to  $67^{\circ} 39'$ , and in either hemisphere, for which latter purpose it has reversible driving-gear and two hour-circles readily interchangeable. Besides a striding level for making the declination axis horizontal, two delicate levels are suspended from the centre of the telescope. A graduated circle and delicate level is also attached to the telescope near its eye end. This, in conjunction with a micrometer in the eye-piece, will qualify the instrument for determining latitude by the differential observation of two stars of nearly equal zenith distances, north and south. The instrument has two micrometers—a parallel wire by the makers, and a double image micrometer by Messrs. Troughton and Simms, precisely similar to those supplied for other stations under the auspices of the Astronomer Royal. The parallel wire micrometer has a contrivance intended to enable the observer to record the readings of the divided head without withdrawing his eye from the eye-piece, as suggested by Mr. Christie, of the Royal Observatory. The form actually adopted by the makers differs both from that employed by Mr. Christie and that prescribed by me. I am unable to express any opinion on its efficiency, as it arrived from the makers after the instrument had been despatched to India, and I could not try it.

The instrument is well supplied with eye-pieces and all necessary adjuncts, and the arrangements for bringing down the various adjusting and slow-motion screws to the observer's hand when observing are very complete, and many of them, I believe, as novel as they are ingenious and effective.

I had but one brief opportunity of trying the object-glass, but that sufficed to satisfy me that it is of a high order of excellence.

*Altazimuth.*—The place of this is supplied by the great theodolite constructed, from my designs, by Messrs.

Troughton and Simms, for the Great Trigonometrical Survey of India, and now about to be employed for the first time. The main features of this instrument were described by me in a paper read before the Royal Society and published in its Proceedings, No. 135, of 1872. I may briefly state here that the horizontal circle is three feet in diameter, read by five equidistant micrometers, the circle being fixed and the micrometers revolving; that the vertical circle is two feet in diameter, read by either two micrometers fixed, or by four capable of being shifted so as to change the divisions and thus reduce errors of graduation; and that the telescope has an aperture of  $3\frac{1}{2}$  in., and a focal length of 36 in., to which can be attached either of two parallel wire micrometers—one for measuring in the vertical, the other in the horizontal plane, according to the class of observation, the wires having both a dark and a bright field illumination.

This is no doubt the most elaborate and most powerful instrument of its class in existence.

*Transit Instrument.*—This is of a peculiar and, I believe, in many respects novel form. It is from the designs of Signor Magnaghi, of Genoa, modified by the makers, Messrs. Cooke, of York, and myself. Signor Magnaghi's object was to produce an instrument capable of determining latitude, as well as of performing the usual functions of a transit instrument, those of determining time and longitude. The telescope has an aperture of 3 in. and a focal length of  $34\frac{1}{2}$  in. with a transit axis of the usual form  $18\frac{1}{2}$  in. in length between the pivot shoulders. The stand is of cast iron, and consists of first a massive circular base plate 24 in. in diameter, supported, according to the system introduced by me, by three shakeless foot-screws, upon a single masonry pillar. On the base plate revolves horizontally a second similar plate with the two pillars cast hollow in one piece with it. This upper revolving plate moves stiffly, and is provided with slow-motion screws and four powerful clamping bolts. When it is bolted to the lower base plate, the two may be considered practically to be one mass. The horizontal motion thus provided is used, first, for effecting the ordinary azimuthal adjustment of the instrument to the plane of the meridian; and secondly, the direction of the meridian having been found, for placing the telescope with great facility in the plane of the prime vertical for the determination of latitude by that method.

An apparatus is also supplied for lifting the telescope and reversing its pivots on their bearings, the transit axis level remaining suspended from the pivots during the process. This arrangement also admits of the instrument being used to determine latitude by the differential observation of two stars of nearly equal zenith distances, north and south; for which purpose the telescope is provided with a parallel wire micrometer and a delicate level.

*Chronograph.*—Col. Tennant attached, justly I think, great importance to means being provided for the electric record of the time observations which form so essential a portion of the undertaking. He wished to have a chronograph which should be capable of recording at the same time, and without confusion, observations made with four different instruments, viz., the Photoheliograph, Equatorial, Altazimuth, and Transit Instrument, and he indicated the apparatus described by Lord Lindsay in Monthly Notices, R.A.S. I therefore examined Lord Lindsay's chronograph, then under construction by Messrs. Cooke, of York, but, though no doubt suitable for a fixed observatory, such as his lordship is establishing, I thought it too large and ponderous for the present service. I accordingly arranged with Messrs. Cooke a much lighter and, I may add, a less costly plan. By substituting continuous bands of paper, similar to those used in telegraphic instruments, for sheets of paper carried by the large barrels employed by Lord Lindsay, great increase of compactness and lightness were secured. Four such bands are

worked by one central clock movement, each or all being readily thrown out of gear at will. The marking is effected by steel pricklers driven by electro-magnets, on the same principle as in the chronograph of the Royal Observatory, Greenwich, though the mechanical details were different. These pricklers can also be thrown out of action by a convenient arrangement of resistance coils. The length of a single second of time can, by changing two wheels, be made either one, three-quarters, or half an inch. I had prescribed that the central clock work should be regulated either by the late Léon Foucault's lever governor or by Mr. Siemens' centrifugal fluid governor, but the maker, without consulting me, applied a Watts ball governor with friction-brake, such as is employed for the driving-clock of equatorials. I did not expect that this comparatively primitive contrivance would secure a sufficiently uniform velocity. But on trial by Capt. Campbell, R.E., and myself, it was found to answer its purpose so well that I am inclined to think a great deal of needless refinement and expense has been wasted on elaborate governors for chronographs.

*Standard Clock.*—This is by Messrs. Cooke, of York, and has nothing peculiar in its construction. It has a Graham's dead beat escapement, and a mercurial (metal jar) compensated pendulum, with the contact apparatus necessary for connecting it electrically with the chronograph.

*Three Journeyman Clocks.*—These were intended by me to be connected electrically with the Standard Clock, and thus show identical time for each of the principal instruments from which the latter might not be visible. I was not satisfied with the mode of driving adopted by the makers, and should have had them altered if time had admitted. Col. Tennant is also dissatisfied with them, but I hope that, with careful adjustment and attention to the batteries and contacts, they may be found effective during the short period of the phenomenon.

It fortunately happened that whilst these instruments were undergoing examination by me, Capt. W. A. Campbell, R.E., of the G. T. Survey of India, who is to assist Col. Tennant with the Venus observations, was in England. The Government, on my application, appointed Capt. Campbell to assist me in testing the instruments, and thus the two objects were gained of securing his valuable experience and skill, and of familiarising him with the instruments which he would have to use.

I have heard from Col. Tennant of the safe arrival at Roorkee of the photoheliograph, altazimuth, chromograph, and clocks, and of the expected arrival in a few days of the Equatoreal, his last letter to me to that effect being dated 9th Oct., 1874. There would only remain the Transit Instrument, which was much delayed in construction. It was despatched hence on Sept. 18, 1874, and is no doubt now in Col. Tennant's hands.

In the foregoing statement I have confined myself to those arrangements which I have been personally concerned in making. But other places in India will be provided with equipments more or less complete for observing the Transit of Venus—amongst others I may mention Peshawur, Bombay, and probably more than one station in the southern part of the peninsula under the care of Mr. Pogson, Government Astronomer at Madras. The Government of India has thus not been unmindful of the just claims of astronomical science.

A. STRANGE, Lieut.-Colonel,  
Inspector of Scientific Instruments  
to the Government of India

Lambeth Observatory, Nov. 1874

#### PRACTICAL SCIENCE AT CAMBRIDGE

DR. MICHAEL FOSTER, in concluding his course of Practical Physiology this term, remarked on the diligence and industry of his class under many difficulties.

At the beginning of the term he asked their indulgence for the imperfect accommodation he was able to offer them. Thirty students had been entered, and the space available was about sufficient, properly, for ten. Three students had to be placed at each table, instead of one. Several other gentlemen joined the class subsequently, making the class number about thirty-five. Two ladies also attended the lectures, and were provided with a separate place of study. Dr. Foster at his last lecture said that in the previous year the want of accommodation had been so keenly felt by himself and class that he was inclined to discontinue his course. He had, however, conducted it through another term, with a larger number of students; and, as the result, although he expressed pleasure at the work accomplished by his class, he was more than ever inclined to give it up. The present course would, however, be completed next term; but he was not able to promise its repetition in the succeeding winter. Want of accommodation militated so greatly against the quality of the work done, and so limited the kind of work that could be attempted, that the benefit seemed almost to be outweighed by the limitations and disheartening accessories.

The publication of these remarks may serve to draw attention to the general condition of practical science in Cambridge. Chemistry and geology are perhaps the subjects for the practical study of which we now have the most reasonable facilities. The Chemical Laboratory has been recently enlarged and improved, and in addition to the ordinary practical courses Prof. Living has this term given lectures with practical illustrations in spectroscopic analysis. The lectures have been given during four successive hours of the afternoon, to four sets of students, the number of students in each class being limited to four or five; so that thoroughly efficient work could be done. The facilities for study at the Geological Museum have been improved by Prof. Hughes. A typical collection of fossils has been selected and arranged by Mr. Keeping, and provided with catalogues. A typical series of minerals has been arranged and catalogued by Mr. W. E. Koch, B.A., of St. John's College, derived from the ample stores accumulated by the late Prof. Sedgwick. Several large series of rock specimens have been more conveniently arranged for inspection, including those catalogued by the Rev. T. G. Bonney. In addition, advanced students have free access to the many valuable special collections in the Woodwardian Museum. The Geological Library in the museum has been improved and catalogued; a valuable section-cutter and an excellent microscope have been purchased, and in other ways the means for the practical study of geology, so far as it can be carried on in a museum, have been greatly improved.

In Experimental Physics the best conditions for practical study have been secured in the building of the Cavendish Laboratory, in its being furnished with some of the most perfect and valuable physical apparatus in existence, and in the appointment of Prof. Clerk Maxwell and his able demonstrator, Mr. Garnett. No doubt at the earliest possible moment a practical elementary course will be organised, to include those observations which every student of natural science should become familiar with. Sufficient time has not yet elapsed since the completion of the laboratory for the establishment of such an elementary class; but when it is established a great boon will be conferred on Natural Science students, who, in the study of biology and geology, labour under many difficulties caused by a want of sufficient practical acquaintance with physics. It would be very desirable, also, if some elementary non-mathematical lectures on physics could be given for the benefit of Natural Science students; such lectures might be given by the Demonstrator, so as not to interfere unduly with Prof. Maxwell's researches and advanced mathematical lectures. It is true that Mr. Trotter gives valuable lectures on physics

at Trinity College, but these are restricted to members of those colleges which are associated with Trinity for Natural Science studies.

The great hindrance to the success of the Cavendish Laboratory at present is the system fostered by the Mathematical Tripos. The men who would most naturally be the practical workers in the laboratory are compelled to refrain from practical work if they would gain the best possible place in the Tripos list. Very few have courage so far to peril their place or to resign their hopes as to spend any valuable portion of their time on practical work; for, while they might be acquiring sound physical conceptions and going through long laborious details, others are assiduously cramming book-work, wearing out their energy in attacking those problems which are here set before the student as affording the best mental training, and in learning those short cuts and dodges which conduce to obtaining marks in an examination. For a man to do practical work in physics at Cambridge implies considerable exercise of courage and self-sacrifice.

Students of the foregoing subjects, however, have better facilities for study than students of Biology. In Practical Physiology and Histology almost everything is required. A large room, properly lighted and fitted, is needed for elementary courses; and, considering the numbers already attracted to Dr. Foster's summer and winter classes, in spite of difficulties and defects, it would seem desirable to provide accommodation for at least a hundred students. Rooms should also be provided, specially adapted for advanced work in Histology, for researches in Physiology, for preparation of experiments and of materials for the classes, and, in addition, a good lecture-room.

In Comparative Anatomy and Zoology the museum has been much improved in the last few years, but its growth is greatly restricted by want of funds. The accommodation for practical dissection of animals consists only of the superintendent's private room, which, at the cost of great inconvenience, has been generously thrown open to students.

Finally, as regards Botany, while there are a good garden and a carefully kept herbarium for systematic study, there is no class of any kind for practical study of Vegetable Histology and Physiology. And yet, recently, the standard for obtaining an ordinary degree in Botany has been considerably raised, and students are expected to show knowledge of the forms, sizes, and development of cells of every kind. The demand for an acquaintance with Vegetable Histology, which, to be real, must be acquired by assiduous and carefully directed microscopical study, while no instruction in such work is given, puts a premium on cramming of the most unfruitful kind, and reduces natural science studies to a lower level than those mathematical and classical studies whose exclusive pursuit scientific men desire to see abandoned. It would be better to examine only in those portions of morphology and classification which can be learnt in a botanic garden, than to set elaborate questions in Histology and Physiology which necessitate elaborate cramming on the part of the student.

G. T. BETANY

Cambridge, Dec. 10

#### M. BECQUEREL ON SOLAR PHYSICS

THE Paris Academy of Sciences having appointed a Commission to consider the founding of an Observatory for Physical Astronomy in the vicinity of Paris, M. Becquerel the elder, a member of the Commission, has expressed his opinion on the subject in a report of which the following is a translation:—

To study the physical constitution of the sun and stars, Astronomy employs in general telescopes and the spectroscope; this last instrument shows us that the heavenly bodies are composed of the same elements that are found in the earth; whence it may be concluded that the forces

governing matter are of universal existence. This question I have considered in a work now going through the press, and which will appear before the end of the year; its title is "On the Physico-chemical Forces and their Intervention in the Production of the Phenomena of Organic and Inorganic Nature." All questions relating to these subjects are there treated, not theoretically, but by the experimental method.

I have endeavoured to show that to arrive at a knowledge of the sun's constitution it is necessary to call to our aid the geological constitution of the globe and the volcanic phenomena from the earliest times down to the present epoch.

The following are the reasons which have led me thus to deal with the subject:—

The identity of formation of the sun and earth and of all the planets which gravitate around our principal star being admitted, the conclusion may be drawn that his present physical condition is the same as that of our planet during the first periods of its formation, when the crust did not exist or had but little thickness. The cooling of the earth has been considerably more rapid than that of the sun by the effects of celestial radiation, the volume of the sun being 1,326,480 times that of the earth. It is thus permitted to compare the chemical and physical effects occurring in the sun at present with those which were produced in the earth at its origin, from which conclusions may be drawn as to the actual constitution of this star.

The collection of vapours which constituted the earth, submitted to a gradual cooling, passed successively from the gaseous to the liquid state, after which its surface became covered by a solid crust, of which the thickness increased with time. There were then produced a mass of chemical and physical phenomena.

We may distinguish three principal calorific epochs during the formation of our planet.

The first is that in which all the elements were in a gaseous state in consequence of a temperature excessively elevated; all the constituents were then dissociated.

The second is that in which, the temperature being sufficiently lowered, affinities commenced to exercise their action; the compounds formed passed successively from the gaseous to the liquid and solid states. During all the chemical reactions which occurred there would be produced an enormous disengagement of electricity arising from the energy of these reactions, and, as a consequence, a recombination of the two electricities which would end with vivid gleams the atmosphere already formed. Thunder would burst forth from all parts.

The third epoch is that in which the temperature, being sufficiently lowered and below 100°, the quantity of water formed would increase so much the more as the temperature was less elevated. This primordial water contained, probably, carbonic, sulphuric, and other acids which would saturate bases; it is to the reactions produced that must be attributed the formation of the great masses of limestone found in various parts of the earth's crust.

I have been led also in my work to treat of the calorific state of the earth in the first phases of its formation, as also of the volcanic phenomena of the same epochs.

As a consequence of the subjects discussed, I have been led to show that atmospheric electricity had a solar origin, and is the cause of the aurora and probably of the luminous phenomena which are produced beyond our atmosphere. I here limit myself to the indication of the consequences to which the study of the forces of nature has led me.

From what precedes it will be seen that the study of the constitution of the sun requires the conjunction, not only of astronomy, but of observers having general knowledge in Physics, Geology, and Chemistry, and possessing a thoroughly practical knowledge of the spectroscope.

R. M.



## REAPPEARANCE OF ENCKE'S COMET

It is quite possible that before the close of the next period of absence of moonlight in the early evening hours, the comet of Encke may be again detected with the large telescopes now to be found in our observatories. The mean motion determined by Glasenapp for the last perihelion passage at the end of December 1871 would bring the comet to the same point of its orbit about 1875, April 11.5, which was very nearly the date of passage through perihelion in 1842. When it was last in aphelion, in the middle of August 1873, I find its distance from the planet Jupiter would be 10'02, and that from Saturn 7'3, so that the perturbations during the present revolution are likely to be small; the comet still approaches near the orbit of Mercury in heliocentric longitude 123°7' and latitude 6°8' N., but it has not encountered that planet since November 1848. Assuming, then, that the least distance from the sun will be attained at midnight on the 11th of April next, we have the following positions of the comet during the period I have named:—

		AT 12 H. GREENWICH TIME		Distance	Distance
1874-75.		R.A.	N.P.D.	from Earth.	from Sun.
		h. m. s.	° ' "		
Dec.	22 ...	22 50 34	88 19 9	1'945	1'919
"	26 ...	22 53 12	88 9 9	1'958	1'874
"	30 ...	22 56 18	87 57 2	1'968	1'828
Jan.	3 ...	22 59 47	87 41 6	1'976	1'781
"	7 ...	23 3 38	87 23 2	1'981	1'733

An acceleration or retardation of four days in the time of perihelion passage will not change the geocentric place more than fifteen minutes of arc, so that if the comet be within reach it may be easily found.

It will be interesting to learn what account some of the large reflecting telescopes with which many amateurs in this country have provided themselves, can give of the comet at this return.

The computation of the perturbations and preparation of an accurate ephemeris for 1875 is understood to be in the hands of Dr. von Asten, of Pulkova; but I am not aware that the results have yet been given to astronomers.

J. R. HIND

Mr. Bishop's Observatory, Twickenham, Dec. 14

## NOTES

SINCE our last week's note, we understand that the whaling steamer *Bloodhound*, of Greenock, has been purchased as the chief vessel of the new Arctic Expedition. Other whalers have been examined by Sir Leopold M'Clintock, but none have been deemed suitable. The *Bloodhound* is a screw steamer, whose engines are nominally 96 horse-power; she is barque-rigged, two years old, strong, sound, and well appointed, and handy either under steam or canvas. It is announced that the vessel chosen to be the consort of the steam-whaler *Bloodhound* in the forthcoming expedition is Her Majesty's ship *Alert*. She is a five-gun steam-sloop of 751 tons old measurement, and 100 horse-power nominal. The *Alert* has been docked at Portsmouth and will undergo a thorough survey. Active preparations for the equipment of the ships will soon commence, but the start will not be made until the latter part of June of next year, as it is considered merely waste of labour and time to push across the north water until the ice has had time to melt and drift out from Smith's Sound. A request has been made by the Foreign Office that the Danish Government will permit their agents at Disco, Proven, and Upernivik to collect hunters, dogs, and dog-drivers for the Arctic Expedition. Capt. Nares is expected to arrive in this country about the end of January, 1875. The Committee for making arrangements with respect to the Expedition sat on Tuesday and Wednesday at the Admiralty for the purpose of deciding on the provisions and clothing to be supplied to the members of

the expedition. They have been occupied hitherto with details as to the route.

*Apogee* of the possible biological results of the Arctic Expedition, we may recall to recollection a few additional details to those given last week of what was accomplished by the *Polaris*. The northern limit actually reached was 82° 16'. Yet at this extreme latitude fifteen species of plants were collected, five of which were grasses. Twenty-six musk oxen were shot in lat. 81° 38'. Dr. Bessels also made a fair collection of insects, principally flies and beetles, two or three butterflies and mosquitos; and birds of seventeen different kinds were shot in 82°, including two Sabine gulls and an Iceland snipe.

DURING the whole of the past week the members of the French Academy of Sciences have had frequent meetings to receive the telegrams from the several French Transit stations. The first, from Janssen, relieved them of a great anxiety, and was published instantly. The most extraordinary measures have been taken to secure the safe transmission of the results of the observations at French stations. The chief of each station is ordered to make four copies of his observations. One is to be left under a cairn, or a tree (if any in the country), or in an excavation, the site to be described in a letter to the Institute; the second is to be handed over to the captain of the first French ship that is met, with instructions to bring it himself to the Institute; the third is to be delivered to the nearest French consul, agent, or ambassador; the fourth is to be kept by the chief of the station himself.

MM. FIZEAU and Cornu, authorised by M. Leverrier, have been making an experiment of the highest importance at the Paris Observatory, the results of which were to be given at Monday's sitting of the Academy. The two savants have been measuring the velocity of transmission of light, by experiments carried on between the Observatory and Monthléry. The light sent to Monthléry is reflected and returns to the Observatory, the distance there and back being 22,000 yards. The experiment has never hitherto been made on so grand a scale, nor with such precautions; ten powerful instruments were used.

HER MAJESTY'S ship *Basilisk*, which has just returned to England after a commission of nearly four years, has (the *Times* states) surveyed about 1,200 miles of coast line, added at least twelve first-class harbours, several navigable rivers, and more than one hundred islands, large and small, to the chart; and, lastly, has been able to announce the existence of a new and shorter route between Australia and China. Till these *Basilisk* discoveries were made, a large archipelago of islands (some as large as the Isle of Wight, and densely populated), a rich fertile country, intersected by navigable rivers, and inhabited by a semi-civilised Malay race, remained unknown to us. After the news of this ship's first discoveries reached England, Lieut. Dawson, R.N. (Admiralty Surveyor), was sent out to join her, and she was ordered to complete and follow them up. This has been done with perfect success, and the whole of the previously unknown shores of Eastern New Guinea have been carefully surveyed, and the route above referred to opened up. The principal part of this work of discovery and surveying has been performed by the captain and officers in small open boats, detached from the ship in some instances for many weeks, and among savages who had never before seen a white face. It is stated that two lofty mountains, about 11,000 feet high, facing each other on the north-east coast of New Guinea, have been named "Mount Gladstone" and "Mount Disraeli." This intelligence will have an interest of rather a tantalising kind for naturalists. There is hardly any part of the world more promising to students of the geographical distribution of living forms than that which the *Basilisk* has surveyed. Collections, more especially of the plants, might doubtless often have been made,



and would have been of the highest possible value. It is much to be wished that with the existence of such opportunities as these some one might be found to put in a word in aid of purely scientific claims. Doubtless it is pleasant to think that the two rival mountains will be a perpetual memory of frowns frowned elsewhere, but how much more pleasant to know something of the things that grow and live upon them.

THE *Irish Times* states that one of the objects of Sir Stafford Northcote's visit to Ireland is to "examine the sites proposed for the establishment in Dublin of an extensive National Museum of Science and Art, analogous in principle, although not in extent, to that at Kensington."

AFTER the Franco-Prussian war of 1870-71, it is well known that in many districts in France a new vegetation sprang up, evidently the result of the invasion. It was believed that this vegetation would become acclimatised. It is not so, however, *L'Institut* informs us; at least very few of the species introduced in this way appear likely to continue to flourish on French soil. In the departments of Loiret and Loir-et-Cher, of 163 German species, the half at least have already disappeared, and the surviving species diminish in vigour each year. Scarcely five or six species would appear to manifest any tendency to become acclimatised; these are, according to M. Nouel, *Alyssum incanum*, *Trifolium resupinatum*, *Rapistrum rugosum*, *Melilotus sulcata*, and *Vulpia ligustica*. On the plateau of Bellevue, where in 1871 many strange species were seen, M. Bureau has been able to find only one—*Trifolium resupinatum*. M. Gaudetroy also, who in 1871 and 1872 found many adventitious plants, has been able to collect only two this year—*Ranunculus macrophyllus* and *Linum angustifolium*.

THE Transactions and Proceedings of the New Zealand Institute always contain a collection of papers of high scientific value, and vol. vi. issued last June is no exception to this rule. It is a bulky volume of some 454 pages, added to which is an appendix of 104 pages more. It may not be known to many of our readers that the New Zealand Institute is composed of the following incorporated societies, each of which includes amongst its office-bearers and members one or more names eminent in science in the colony and well known in this country. The individual societies are, the Wellington Philosophical Society, Auckland Institute, Philosophical Institute of Canterbury, Otago Institute, and the Nelson Association for the Promotion of Science and Industry. On the council of these various societies occur such names as Dr. Hector, F.R.S., Dr. Haast, F.R.S., Mr. W. T. L. Travers, F.L.S., Mr. T. Kirk, F.L.S., &c. Each one of the societies numbers amongst its members the scientific men of its neighbourhood, and amongst the honorary members of the incorporated Institute are such names as Charles Darwin, Prof. Huxley, Dr. Hooker, Sir Charles Lyell, Prof. Owen, Prof. W. H. Flower, &c. These facts are sufficient to show that New Zealand is particularly fortunate in having amongst its residents men eminent in various branches of science. No colony has shown more aptitude for scientific work than New Zealand, and perhaps no other colony can boast of a society approaching so near to our Royal Society, both as regards the value of the papers contributed and the range of scientific investigation. Zoology, Botany, Chemistry, and Geology are all represented by numerous papers in each section. In the first, Dr. Haast contributes an illustrated article "On *Harpagornis*, an extinct genus of gigantic raptorial birds of New Zealand;" while Dr. J. E. Gray, who is an hon. member of the Institute, supplies a "List of Seals, Whales, and Dolphins of New Zealand," and Capt. F. W. Hutton some "Notes on some New Zealand Fishes." In Botany we find a "List of the Algae of the Chatham Islands, collected by H. H. Travers, and examined by Prof. John Agardh, of Lund;" "Notes on the Flora of the

Province of Wellington, with a list of plants collected therein," by John Buchanan; and by Mr. W. T. L. Travers a few notes "On the spread of *Cassine leptophylla*." In Chemistry, Mr. W. Skey talks about the Mineral Oils of New Zealand; and in Geology are papers "On the Formation of Mountains," by Capt. Hutton; "On the Extinct Glaciers of the Middle Island of New Zealand," by W. T. L. Travers; "On the Fossil Reptilia of New Zealand," by Dr. Hector; besides other interesting papers.

THE Cambridge Natural Science Club has held eight meetings this term on Saturday evenings, and some good papers have been read by the members at the meetings in their rooms, usually followed by a discussion. The attendance has mostly been under the average of other terms, on account of some of the members being candidates in the Natural Science Tripos now being held. The following are some of this term's papers:—"The Reniportal Circulation," by Mr. P. H. Carpenter (Trin. Coll.); "Vegetation as affecting Climate," by Mr. J. M. F. H. Stone (St. Peter's Coll.); "Tides," by Mr. Arthur Buxton, B.A. (Trin. Coll.); "Comparisons of Nervous Systems of Vertebrata and Invertebrata," by Mr. T. W. Bridge (Trin. Coll.); "The Influence of Molecular Structure upon some Organic Bodies," by Mr. E. B. Sargant (Trin. Coll.); "The Theory of the Identity of Matter," by Mr. P. R. Ogle (St. Peter's Coll.); "The Development of Blood," by Mr. S. H. Vines (Christ's Coll.)

IT is gratifying to see a growing tendency in the not professedly scientific press to endeavour to account for the causes of phenomena which it is called upon to notice; thus, consciously or unconsciously, treating occurrences in a scientific spirit. For example, *The Country*, in speaking of the migration of birds, states that woodcocks have been unusually scarce in Cornwall for the past two or three years, nor is the present season an exception to the rule, for, notwithstanding favourable winds and moonlight nights, they continue *rare aves* in the county. In attempting to account for this, *The Country* very pertinently suggests that improved agriculture has more or less destroyed the feeding grounds, though, as the same may be said of other parts of the kingdom where such game is not scarce, this cannot be the only cause.

A TELEGRAM to Cairo, dated the 5th inst., from the Governor-General of the Soudan, announces that the entire kingdom of Darfour has accepted annexation to Egypt.

THE American Society of Paris proposes to hold an "International Congress of Americanists" at Nancy, near Paris, on the 22nd of July, 1875, the object being to bring together those who are interested in the history of America prior to its discovery by Columbus, and in the interpretation of the monuments and of the ethnology of the native races of the New World. An exhibition of American Archeology is to be held at the same time. Any American can be enrolled as a member of the Congress by forwarding the sum of twelve francs to Mr. Lucien Adam, secretary of the American Society of Arts, Rue Bonaparte, in Paris.

A SERIES of experiments has lately been made by the Russian Government with reference to the use of electricity for the headlight of locomotives, a battery of forty-eight elements making everything distinct on the railway track to a distance of over 1,300 ft.

A CURIOUS phenomenon frequently met with in the Indian Ocean, the real cause of which has not yet been ascertained, is the existence off Malabar, and in certain spots along the Coromandel coast, of vast mud banks, and of tracts of mud suspended in the sea, wherein many kinds of fish find abundance of food, immunity from much disturbance in the surrounding element, and a locality in which to breed. The exact cause of the existence of these large tracts of sea wherein mud remains in solution is still a mystery, but at any rate the ocean is so smooth that, even during the height

of the south-west monsoon, vessels can run for shelter into their midst, and once there are as safe as when inside a breakwater. If the surface is so still, of course so is the water below, and such spots seem to be well suited to the siluroid fishes. These curious patches of sea which appear in a continually perturbed state, and the sea-bottom in the locality, would probably well repay careful scientific observation.

THE manufacture of isinglass, generally supposed to be confined to Russia and North America, or other countries where the sturgeon is found in abundance, is carried on to a considerable extent in India, principally from the air-vessels of several varieties of acanthopterygian fishes, and particularly, different kinds of perch, as well as from other fish. There is room for a great extension of the trade, as isinglass, the purest known form of animal jelly, has, in a measure, had its consumption checked by its high price, and substitutes are employed, such as gelatine, of which it is itself the purest form.

At the last meeting of the British Association a committee was appointed to investigate the circulation of the underground water in the New Red Sandstone and Permian Formations of England, and the quantity and character of the water supplied to the various towns and districts from these formations. Prof. Hull, M.A., F.R.S., director of the Geological Survey of Ireland, is chairman, and Mr. C. E. de Rance, F.G.S., Scientific Club, 7, Saville Row, London, W., secretary. The following queries have been circulated by the committee for the purpose of eliciting information in connection with the important subject:—1. Position of well, or wells, with which you are acquainted. 2. Approximate height of the same above the mean sea level. 3. Depth from surface to bottom of shaft of well, with diameter. Depth from surface to bottom of bore-hole, with diameter. 4. Height at which water stands before and after pumping. Number of hours elapsing before ordinary level is restored, after pumping. 5. Quantity capable of being pumped in gallons per day. 6. Does the water level vary at different seasons of the year, and how? Has it diminished during the last ten years? 7. Is the ordinary water level ever affected by local rains, and if so, in how short a time? And how does it stand in regard to the level of the water in the neighbouring streams, or sea? 8. Analysis of the water, if any? Does the water possess any marked peculiarity? 9. Nature of the rock passed through, including cover of drift, with thickness. 10. Does the cover of drift over the rock contain surface springs. 11. If so, are they entirely kept out of the well? 12. Are any large faults known to exist close to the well? 13. Were any salt springs or brine wells passed through in making the well? 14. Are there any salt springs in the neighbourhood? 15. Have any wells or borings been discontinued in your neighbourhood, in consequence of the water being more or less brackish? If so, if possible, please give section in reply to query No. 9.

We have received, among the results of the geographical and geological explorations of the Western (U.S.) States, the annotated list of the birds of Utah, by Mr. H. W. Henshaw, containing the names of 214 species, of which 160 were either taken or noted in the expedition. The author thinks that if collections were, as they have not yet been, made during the spring months, several extra species would have to be added to the collection.

COAL is beginning to attract attention in New South Wales, in some parts of which the mineral is being found in abundance, and the pre-eminence which gold and copper have maintained will be assailed by the increasing importance of the newly worked product. A seam, seven feet thick, has been opened at Boughton Creek, near the Shoalhaven River, and not far from the Moss Vale Railway Station; so that every circumstance of locality is in favour of its profitable working.

The *American Chemist* for August and September, which we

have just received, contains a full account of the proceedings at the Priestley Centenary in Northumberland, Pa., on July 31 last. There was then a large and enthusiastic gathering of men of science and others, and several valuable addresses were given. The principal one in the numbers before us is by Prof. B. Silliman, being a long, minutely detailed, and carefully compiled paper on "American Contributions to Chemistry."

We are gratified to see that the *Geographical Magazine* has been so successful that the price is to be reduced to one shilling.

THE additions to the Zoological Society's Gardens during the past week include a Chamois (*Rupicapra tragus*) from the Pyrenees, presented by Mr. A. Wilson; a White-fronted Capuchin (*Cebus albiviridis*) from South America, presented by Mrs. Carpenter; a common Boa (*Boa constrictor*) from South America, presented by Capt. E. C. Kemp; two Barred-tailed Pheasants (*Phasianus recessus*) from North China, received in exchange.

#### ON THE STRUCTURE OF STIGMARIA \*

AT a meeting of the Manchester Literary and Philosophical Society, held on October 20, Mr. Binney called in question some conclusions at which I had arrived and had published in Part II. of my memoirs on the Structure of the Coal Plants, respecting the organisation of *Stigmara*. Mr. Binney further published an abstract of his remarks in Part II. of vol. xiv. of the Society's Proceedings. Believing that Mr. Binney's observations, if allowed to pass unnoticed, may mislead some palæontologists unacquainted with *Stigmara*, I feel called upon to reply to them through the same channel as that which he has employed for their promulgation. The general features of the plant known for half a century as *Stigmara fœcoides* have been so well described by Lindley and Hutton, Dr. Hooker, Mr. Binney, and Brongniart, that no one familiar with those descriptions can fail to recognise it without difficulty. That plant consisted of a central medulla, surrounded by a cylinder of scalariform vessels arranged in radiating wedges, very distinctly separated by two kinds of medullary rays (primary and secondary), the whole being enclosed in a thick bark, from the surface of which spring numerous large cylindrical rootlets. The vascular cylinder gives off numerous large vascular bundles of scalariform vessels, which proceed outwards, through the conspicuous primary medullary rays, to reach the rootlets.

The dispute between Mr. Binney and myself resolves itself chiefly into three points: (1), the structure of the medulla of *Stigmara*; (2), the source whence the vascular bundles supplying them are derived; and (3), the nature of some vascular bundles which both Mr. Binney and M. Goepfert have figured as existing within the medulla, and one of which is prolonged radially in M. Goepfert's example through a medullary ray. Mr. Binney and M. Goepfert believe that the cellular medulla of *Stigmara* contained bundles of very large scalariform vessels, and that those bundles proceeded outwards to supply the rootlets. On the other hand, in my second memoir, referred to by Mr. Binney, I not only expressed my conviction, but demonstrated the absolute certainty, that such was not their origin. I adhere to the same opinion as I previously expressed, and have the specimens on the table which prove its correctness. The fact that these bundles were derived not from the medulla, but from the vascular wedges of the woody cylinder, was illustrated by the figures 43, 44, and 47 of the memoir referred to, figures which accurately represent, not conditions occasionally met with, but those which characterise every specimen of the true *Stigmara fœcoides*. In the memoir I further affirm that immediately within the woody cylinder there exists a delicate cellular tissue, and state that one of my specimens makes it perfectly clear that the entire medulla consisted of similar cells, unmixured with any vascular bundles whatever such as were represented in M. Goepfert's and Mr. Binney's figures, and the accuracy of which is, was, and it appears still is, endorsed by Mr. Binney. After thus endorsing what I believe to be a grave mistake, Mr. Binney proceeds to justify his doing so by appealing to a specimen which I have not seen, but which Mr. Binney's own description convinces me is a plant altogether different alike from the *Stigmara* of authors, and from M.

\* A paper read before the Manchester Philosophical Society, by Prof. W. C. Williamson, F.R.S., Nov. 17.

Goepfert's and Mr. Binney's own figures. Mr. Binney describes his new specimen as having a radiating woody cylinder, immediately within which is a second series of large vessels not arranged in radiating wedges, and which Mr. Binney says is "something like a medullary sheath, enclosing a medulla composed of very small and short barred tubes or utricles, in which are mingled large vascular tubes or utricles." Though this use of vague terms renders the sense obscure, I presume that Mr. Binney simply means that in the medulla of his plant a vascular cylinder encloses a cellular medulla, or, in other words, that his specimen has a Diploxyloid axis. That Mr. Binney possesses a specimen having the above structure, and giving off rootlets from its periphery, I have no reason for doubting, since in the memoirs already quoted I have described a similar structure under the name of *Diploxyton stigmarioides*, and respecting which I make the following observations:—"It is possible that the plant may, like *Stigmaria*, prove to be the uppermost part of a root of some of the other forms" (i.e. of Lepidodendroid stems), "though I have never yet found it associated with any rootlets, and it may be a fragment from the base where stem and roots united" (loc. cit., p. 239). I arrived at the above conclusions because I found in the specimen described, evidence that large rootlet bundles were given off from the woody zone as in the true *Stigmaria*. But I affirm that out of hundreds of *Stigmarian* fragments that I have examined, I have only found two possessing this structure, and I unhesitatingly express my conviction that Mr. Binney's specimen is another example of an equally rare type, both being entirely distinct from *Stigmaria ficoides*, to which latter plant alone is referable Mr. Binney's previously published figures, M. Goepfert's description and figures of which Mr. Binney approves, and mine which he rejects.

Mr. Binney proceeds to say: "The size of these large vascular tubes or utricles in the medulla exceeding anything so far as his knowledge extended, hitherto observed in fossil plants, shows that it was easily decomposed, and thus accounts for the general absence of the medulla in *Sigillaria* and its roots." To this reasoning I must altogether demur. Size has nothing whatever to do with the preservation of the tissues in fossil plants. Vascular structures strengthened by transverse bars of lignine are equally well preserved, whether they are large or small. The medulla of *Stigmaria* disappeared or became much disorganised because it consisted of an unusually delicate cellular tissue with extremely thin walls. This tendency to decay was more manifest towards the centre of the medulla than at its circumference. Specimens on the table exhibit this peripheral part of the cellular medulla in exquisite perfection, giving off its characteristic cellular prolongations constituting the medullary rays, as described in my memoir. And yet this beautiful cellular tissue occupies the position which Mr. Binney says was occupied by "large vascular tubes or utricles." The specimens referred to showing these conditions constitute unanswerable facts.

Mr. Binney correctly notes the resemblance of the inner vascular cylinder in his specimen to his "medullary sheath." I have already said the same thing in several of my memoirs, and M. Brongniart said it before either of us. But this very homology, if correct, indicates the probability of Mr. Binney's specimen being a fragment derived from the junction of stem and root rather than a true root, since in living plants possessing a medullary sheath, that sheath, as every botanist knows, is never prolonged into the true roots, for the simple physiological reason that its origin is directly connected with that of the leaf formations of the ascending axis.

As I have already observed, M. Goepfert's and Mr. Binney's previous figures represent a structure altogether different from that now described by Mr. Binney. Instead of the continuous inner vascular cylinder of the latter, M. Goepfert's figure displays two detached, unsymmetrically arranged, vascular bundles in the interior of the medullary cavity. I have already affirmed my conviction that these belong to intruded rootlets of a *Stigmaria*, and are in no respects part of the true medullary axis. On the other hand, Mr. Binney says that "they are certainly not intruded rootlets, as anyone who examines the learned author's plates can satisfy himself." On this point Mr. Carruthers writes to me on Nov. 2: "No one who is accustomed to sections of *Stigmaria* can fail to see that Goepfert has mistaken the accidental rootlets of *Stigmaria* penetrating the decayed axis for an organic part of that axis." I may allow this opinion of an experienced botanist, with which I wholly concur, to neutralise that of Mr. Binney, who further says: "It is very improbable that they" (i.e., Goepfert's vascular rootlets) "had ever been introduced into

the axis after the pith had been removed." To this I reply that it is an extremely rare thing to find any such axis which does not contain more or less of these rootlets. My cabinet is full of such examples, and in two specimens on the table, one of which has been lent me by Capt. J. Aitken, of Bacup, similar rootlets not only exist in the central axis, but have penetrated the medullary rays as in M. Goepfert's specimen.

Mr. Binney, referring to my comments upon his previous memoir, says that in "that memoir mention is only made of the large vascular bundles found in the axis, without calling them vascular or any other vessels." I do not very clearly understand what this sentence means, but I presume it is intended to imply that Mr. Binney never affirmed that the pith of *Stigmaria* contained vascular tissues, and that I have misrepresented him in stating that he had done so. I can only answer this by giving Mr. Binney's words:—"The most important circumstance thus developed is the existence of a double system of vessels in *Stigmaria*, first shown by Goepfert, and the consequent approach in this respect to *Diploxyton*, Corda. In *Diploxyton*, however, the inner system forms a continuous cylinder, concentric with and in juxtaposition to the wedges of wood forming the outer; while in *Stigmaria* the same inner system is broken up into scattered bundles, apparently unsymmetrically arranged in the medullary axis or pith of the plant" (*Quarterly Journal of the Geological Society*, vol. xv. p. 17); and on p. 78 of the same memoir, describing the specimen represented by Fig. 2, he says, "The axis is filled with eleven or twelve large vessels of circular or oval form," and the same structures are again spoken of as "vessels" no less than six times in the next seven lines, with the further remark that "altogether these angular vessels remind me somewhat of the vascular tissue in the middle of *Anabatha*" (loc. cit., p. 78). It is true that in two places Mr. Binney applies to these structures the term "utricles," by which, I presume, he means cells; but such a term, applied to such tissues, is equally applicable to all known fibro-vascular structures, and is simply equivalent to saying that scalariform vessels have no existence.

I have entered into these details because by promulgating vague and groundless doubts respecting work already carefully done, Mr. Binney's communication tends to re-introduce confusion into questions that have been virtually settled. It does this through failing to discriminate between things that differ. His introductory remarks refer to the common *Stigmaria ficoides*, whilst his justification of those remarks rests upon a plant of a very different character, and which I am absolutely certain is not the common form of *Stigmaria*.

#### VEGETATION OF THE LIBYAN DESERT

IN Dr. Ascherson's report on the vegetation of the Libyan Desert, published in the *Botanische Zeitung*, there are some interesting notes on the fall and renewal of the leaves of deciduous trees. In our climate we have little difficulty in understanding the distinction between evergreen and deciduous trees and shrubs, because the greater part of those that change their leaves cast the old ones in autumn or early winter; and evergreens with flat leaves have them more or less coriaceous. But even with us there is a gradual transition from evergreen to deciduous through *Eunonymus europæus* and *Ligustrum vulgare*, both of which have strictly evergreen congeners in *Eunonymus japonicus* and *Ligustrum japonicum*. Some few years ago Hoffmann started a theory that sempervivence could be artificially produced, and there is no doubt that climate influences to a great extent the length of the period during which really deciduous species hold their foliage; but it appears far more probable that these are physiological peculiarities not altogether dependent upon climate, as we find evergreen and deciduous species growing in the same regions and under precisely similar conditions. Some evergreens do not change their leaves at all, and even retain them for many years or all their lifetime; *Arctostaphylos uva-ursi*, for example. *Taxodium distichum*, one of the few deciduous Coniferae, offers a very curious phenomenon, inasmuch as the ultimate branchlets are deciduous. The observations chronicled by Dr. Ascherson agree almost entirely with our own experience. On his outward journey he traversed 25° of lat. in less than a month, which gave him an excellent opportunity for studying the conditions of the same species under very diverse climates. Thus, in the plains of Lombardy many deciduous trees, and especially *Morus alba*, were still partially covered with foliage on the 19th

of November, the same species having long previously shed their leaves in Germany. In a similar manner, the fig-trees in Lower Egypt ( $31^{\circ}$  N. lat.) were partially clothed with foliage at the beginning of December, and in Upper Egypt ( $27^{\circ}$  N.) were still in full leaf, whilst already, on the 24th of November, they were quite bare in the Apulian plain ( $41^{\circ}$  N.). On the 11th of December, the pomegranate trees in the gardens of Siout were in yellow leaf, and on New Year's Day, 1874, the apricot trees at Farafreh were still in their prime of green leaf. Hence, one might readily imagine that on approaching nearer the equator these same species would exhibit no interval between the fall and the renewal of the foliage, and thus, to all intents and purposes, become evergreen. But this phenomenon was only verified in the case of the little cultivated peach trees of the oases, in which it may not be constant. Moreover, the peach tree shows the same tendency in mild seasons with us. In the oases, at the beginning of March, when the trees began to blossom and make new growth, the old leaves were still fresh and capable of assimilation. All other deciduous trees and shrubs cultivated in the gardens of Kasr Dghakel ( $25^{\circ} 45'$  N. lat.), including the grapevine, apricot, apple, pomegranate, plum, fig, mulberry, and willow (*Salix safsaf*), had lost their foliage on the arrival of Dr. Ascherson, or became leafless before the end of January. It should be mentioned that the fall of the leaf in this region does not proceed with the same regularity as at home, for it is not unusual to see quite naked and fully clothed trees of the same species standing side by side. Again, the presence of abundance of moisture has the effect of enabling the trees to carry their old foliage longer and put forth their new earlier than trees growing in drier situations. And some of the willows growing by water were quite evergreen; that is, after the manner of the peach trees mentioned above. But the apricot, one of the most abundant trees, rarely retained even a few scattered old leaves on the appearance of the flowers. The same was observed of the grapevine, fig, and mulberry. By Feb. 20 the apricot trees were in full blossom, and by March 10 in full foliage, so that there was only an interval of four or five weeks between the fall of the old foliage and complete development of the new. The apple and plum behaved in a similar manner, the pomegranate was a little later, the fig next in order, and finally the mulberry; whilst these same things, in the reverse sense, lost their leaves first. From the preceding notes it seems that the fall and renewal of the leaf is an essential constitutional peculiarity, which is modified by climatal conditions, but not entirely subject to them. A more striking illustration of this fact may be found in exotic deciduous trees planted in Egypt. Dr. Ascherson noted more particularly the summer fall of the leaves of *Poinsettia pulcherrima*, a South American shrub, and *Albizia lebbek*, a native of the East Indies. The former is in the full splendour of its inflorescence in December, and quite leafless in April, remaining so, it is said, until the autumn. The *Albizia* is extensively planted as an avenue tree. It sheds its foliage in April, but soon renews it. Both of these plants lose their leaves in their native countries during the dry, and renew them with the opening of the rainy season.

### SCIENTIFIC SERIALS

*Journal de Physique*, III., No. 34, Oct. 1874.—This number commences with the first portion of a paper by M. J. Bertrand, entitled "Demonstration of Theorems relating to Electro-dynamic Actions." The object of this paper is to simplify Ampère's demonstrations of the theorems of electro-dynamics.—Arrangement for obtaining projections of the metallic rays and their reversal, by M. Boudreaux. Instead of the electric light or oxyhydrogen flame, the author employs a mixture of the chlorate of the metal with one-sixth of its weight of powdered gum-lac. The mixture is inflated in a carbon crucible placed in a lantern provided with a vertical slit. Reversals of the metallic lines are effected by allowing a beam of white light (Drummond or sun-light) to pass through the deflagrating mixture and analysing the resulting rays by prisms. By allowing the sun-light to fall only on one-half of the slit, the coincidence of bright with dark lines can be shown.—M. Mascart contributes a paper describing two pieces of apparatus for obtaining the phenomena of interference.—On the magnetisation of steel, by M. E. Bouty.—This number contains a translation of Lord Rayleigh's paper on the manufacture and theory of diffraction gratings from the *Philosophical Magazine* for February and March.—Sensibility of silver bro-

mide to rays supposed to be chemically inactive, by H. Vogel, from *Poggendorff's Annalen*.—From the same journal there is a paper by H. Streintz, on changes in the length and elasticity of a wire under the influence of an electric current.—From the Proc. Roy. Soc. there are translations of Prof. Tyndall's paper on the transmission of sound, and Mr. Norman Lockyer's note on a new class of absorption phenomena.

*Zeitschrift der Oesterreichischen Gesellschaft für Meteorologie*, Nov. 15.—In this number Dr. Hann treats of some of the consequences of the laws of change of temperature in air undergoing change of volume. The following are some of the results of his argument, which is full of interest. The rate of cooling of ascending air varies so much with the conditions of time and place that it cannot be expressed by any general law. But both in Germany and in the tropics the mean rate lies between  $0^{\circ}5$  and  $0^{\circ}6$  C. for every 100 metres. Air warmed at the surface of the earth does not continue to rise until it reaches a level where the temperature corresponds with its own (reduced), but becomes thoroughly mixed with other strata before reaching that height. Temperature falls more rapidly with increase of height in bad than in fine weather. In a descending current there can be no condensation of moisture, and so in it the theoretical increment of  $1^{\circ}$  C. does take place. We would expect this current to clear the sky. But in fact we find that a descending current often brings rain as well as warmer weather. Our moist west winds do not bring their moisture from the tropics, but the Anti-trade, becoming warmer as it descends, collects a fresh quantity of vapour and precipitates it again when cooled by radiation or ascent of mountain slopes. The formation of hail and phenomena of hailstorms are best understood by supposing, with Keye, the lower hot moist strata to rise rapidly to a great height, not the upper air to descend, as it has been shown that this would become much warmer in descending. A cold wind blows first in the higher parts of the atmosphere, and the over-heated air below rushes upward with unusual energy to a height where precipitated moisture freezes as it falls. This ascending movement of warm air, and the further impulse given to it by liberation of the latent heat of vapour, appear to play a large part in the production and continuance of falls of rain. Dr. Hann holds the barometric minimum in the middle of a storm area to be a mechanical effect of the whirling movement of the air, and the moving force in cyclones to be the latent heat of vapour.

### SOCIETIES AND ACADEMIES

LONDON

Royal Society, Dec. 3.—"On the Coefficient of Expansion of a Paraffine of high boiling-point," by G. F. Rodwell, F.R.A.S., F.C.S., Science Master in Marlborough College. Communicated by Prof. Stokes, Sec. R. S.

The author, after giving an account of his researches, concludes that paraffine is a body which undergoes a most unusual expansion in passing from its ordinary solid condition to the high boiling-point which it possesses. He does not remember any other substance of a high boiling-point which occupies at the boiling-point a volume which is one-half as large again as the volume at the ordinary temperature. In an accompanying table he has introduced, side by side with the paraffine curve, the expansion curves of mercury, iodide of silver, and terboronide of phosphorus, one of the most expansible liquids known, if we except such bodies as ether, bromide of ethyl, acetate of methyl, &c., the boiling-point of which is below  $100^{\circ}$  C., and which, therefore, could not be easily introduced into the table for comparison with a body which boils at nearly  $400^{\circ}$  C.

Dec. 10.—"On the effect of Heat on the Iodide of Silver," by G. F. Rodwell, F.C.S. Communicated by Prof. F. Guthrie, F.R.S.

- The author endeavours to prove the following main facts:—
1. That the iodide of silver exists in three allotropic forms, viz. (a) at temperatures between  $116^{\circ}$  C. and its fusing-point, as a plastic, tenacious, amorphous substance, possessing a reddish colour, and transparent to light; (b) at temperatures below  $116^{\circ}$  C. as a brittle, opaque, greenish-grey, crystalline mass; and (c) if fused and poured into cold water, as an amorphous, very brittle, yellow, opaque substance.
  2. That the iodide possesses a point of maximum density at or about  $116^{\circ}$  C. at the moment before passing from the amorphous into the crystalline condition.
  3. That if we allow a mass of molten iodide to cool, the fol-

lowing effects may be observed:—(a) at the moment of solidification a very considerable contraction takes place; (b) the solid, on further cooling, undergoes slight and regular contraction after the manner of solid bodies in general, until (c) at or about  $116^{\circ}$  C. it undergoes sudden and violent expansion, passing from the amorphous into the crystalline condition; (d) after undergoing this expansion the mass on further cooling undergoes slight expansion, and (e) the coefficient of contraction diminishes as the temperature decreases (or, otherwise expressed, the coefficient of contraction augments with the temperature).

"On the Multiplication of Definite Integrals," by W. H. L. Russell, F.R.S.

Geological Society, Dec. 2.—Mr. John Evans, F.R.S., president, in the chair.—The following communications were read:—On the femur of *Cryosaurus eimeris*, Seelye, a Dinosaur from the Oxford clay of Great Grandsen, by Mr. Harry Govier Seelye, F.L.S., Professor of Physical Geography in the Bedford College, London. The author described this femur as showing a slight forward bend in the lower third of the shaft, and as having the terminal portions wider in proportion to the length of the bone than in any described Dinosaurian genus. He pointed out its differences from the corresponding bone in *Megalosaurus*, *Iguanodon*, and other genera. The length of the femur was stated to be about one foot.—On the succession of the ancient rocks in the vicinity of St. David's, Pembrokehire, with special reference to those of the Arenig and Llandoilo groups and their fossil contents, by Mr. Henry Hicks. In the first part of this paper the author described the general succession of the rocks in the neighbourhood of St. David's from the base of the Cambrian to the top of the Tremadoc group, and showed that they there form an unbroken series. The only break or unconformity recognised is at the base of the Cambrian series, where rocks of that age rest on the edges of beds belonging to a pre-Cambrian ridge. In the second part the author gave a minute description of the rocks, comparing the Arenig and Llandoilo groups, as seen in Pembrokehire, with each other and also with those known in other Welsh areas. Each group he divided into three subgroups, chiefly by the fossil zones found in them. 1. The *Lower Arenig* was stated to consist of a series of black slates about 1,000 feet thick, and to be characterised chiefly by a great abundance of dendroid graptolites. 2. *Middle Arenig*.—A series of flags and slates, about 1,500 feet thick, and with the following fossils:—*Ogygia scutatrix*, *O. peltata*, *Ampyx Salteri*, &c. 3. *Upper Arenig*.—A series of slates, about 1,500 feet in thickness, only recently worked out, and found to contain a large number of new and very interesting fossils, belonging to the following genera, viz.: *Ilanus*, *Ilanopsis*, *Placoparia*, *Barrandia*, &c. 4. *Lower Llandoilo*.—A series of slates and interbedded ash, equivalent to the lowest beds in the Llandoilo and Builth districts, and containing species of *Egina*, *Ogygia*, *Trinucleus*, and the well-known graptolites *Didymograptus Murchisoni* and *Diplograptus foliaceus*, &c. 5. *Middle Llandoilo*.—Calcareous slates and flags with the fossils *Asaphus tyrannus*, *Trinucleus Lloydi*, *Calymene cambrensis*, &c. 6. *Upper Llandoilo*.—Black slates and flags, with the fossils *Ogygia Euckii*, *Trinucleus fibriatus*, &c. The Arenig series was first recognised in North Wales by Prof. Sedgwick about the year 1843, and was then discussed by him in papers presented to the Society. The Llandoilo series was discovered by Sir R. Murchison previously in the Llandoilo district, but its position in the succession was not made out until about 1844. The Geological Survey have invariably included the Arenig in the Llandoilo group; but it was now shown that this occurred entirely from a mistaken idea as to the relative position of the two series, which were shown to be entirely distinct groups, the equivalents of both groups being present in Carnarvonshire, Shropshire, and Pembrokehire, but the Llandoilo group only of the two being developed in Carnarvonshire. The lines of division in the series were said to be strongest at the top of the Menevian group and at the top of the Tremadoc group, these lines being palaeontological breaks only, and not the result of unconformities in the strata.

Anthropological Institute, Dec. 8.—Mr. J. E. Price, F.S.A., in the chair.—Mr. M. J. Walhouse read a paper on the existence of a leaf-wearing tribe on the western coast of India. The author's residence at Mangalore for some years afforded him the opportunity of studying the habits of the native tribes of South Canara, and in the present communication he recorded a few facts concerning the Karagars, a remnant, now numbering only a few hundreds, of the aboriginal slave castes whose distinctive peculiarity was the habit of wearing aprons of woven

twigs and green leaves over the usual garment. The custom at present is observed by the women only, who think that abandoning it will bring them ill luck. The author maintained that the leaf was a badge of degradation, and was a survival of a very ancient custom. The unwavering truthfulness of the Karagars is proverbial, and should be remarked as affording a complete refutation of Mr. Mill's assertion, that savages are invariably liars. The paper contained many interesting facts concerning the physical characteristics, traditions, religious rites, and habits of the tribe.—A paper by Mr. Rooke Pennington was read, on some tumuli and stone circles near Castleton, Derbyshire. It comprised a full account of the exploration of the barrow of Elden Hill, measuring 49 feet in diameter, which yielded bones of man, horse, and rat in great abundance, and a red deer's antler that had been worked. A few feet deeper was discovered a grave, containing the skeleton of a young person that had been buried in a contracted position; no implements accompanied it, but it appeared to have been interred with much barbaric pomp. On the top of Siggett Hill was another barrow of somewhat less dimensions, in which was found a fine skeleton with an inverted urn, of the usual type, containing burnt bones. Evidence was adduced to prove that the corpse was not burnt until after the funeral feast was concluded, and the bones of the animals eaten were cast at the same time and into the same fire with the human body. This was one of those barrows which had led the author to conclude that in Derbyshire, at any rate, no connection can be established between the Neolithic age and contracted burial, and the bronze age and incineration.—Major Godwin-Austen contributed some further notes on the stone monuments of the Khasi Hills.

Mathematical Society, Dec. 10.—Prof. H. J. S. Smith, F.R.S., president, in the chair.—Prof. Cayley gave an account of his paper on the potentials of polygons and polyhedra.—Two notes from M. Mannheim to J. J. Sylvester, F.R.S., were, in the latter gentleman's absence, communicated by Mr. Tucker. The first note contained an elegant geometrical demonstration of the following propositions. *ABCD* is a quadrilateral whose sides are of invariable magnitude, such that  $ab = ad$  and  $bc = cd$ . The points *a* and *b* are fixed; if *m* be a point rigidly connected with *b*, it will trace out, as the quadrilateral changes its form, the pedal of a circle. The problem has been treated in an analytical form by Prof. Cayley in a communication to the Society on the determination of the position of the node of a quartic curve, mentioned also in a paper read before the same Society by Mr. Samuel Roberts as a case of three-bar motion. This Mr. Cayley observed to be the inverse of a conic. Mr. Sylvester calls attention to M. Mannheim's proof as a very beautiful and purely geometrical one.—The second note is connected with a geometrical proof of a proposition thus stated by M. Mannheim:—"Lorsque le quadrilatère *a, g, m, d*, dont les côtés sont inégaux, mais dont les diagonales sont perpendiculaires entre elles, se déforme de façon que le sommet *a* décrive une circonférence (*o*) et les sommets *g, d*, des circonférences ayant même centre *s* sur la diagonale *ma*, le sommet libre *m* décrira une anallagmatique du 4<sup>e</sup> ordre." This note relates to seven-bar motion, and is Peaucellier's motion, generalised by substituting for his rhomb any quadrilateral in which the two diagonals are at right angles, one case of which is the kite or spear-head form.

Royal Geographical Society, Dec. 14.—Major-General Sir H. Rawlinson, K.C.B., presided. The principal business was the reading of the report of the Livingstone Congo Expedition, by Lieut. W. T. Grandy, R.N. The President opened the proceedings by announcing the receipt of an interesting letter at the Foreign Office from Lieut. Cameron, the substance of which we have already given. Lieut. Cameron expressed his confident opinion, founded on Arab information, that the Luabala river was in reality the Congo. Mr. Markham then read Lieut. Grandy's report, which was an itinerary of the writer's journey to the interior up to the date of his recall. Roads were being made by means of which the troops would be able to intercept the transit of slaves to the coast, and encouragement was being given to cultivate the india-rubber tree, of the value of which in Europe the natives had been hitherto ignorant. The chiefs had been exceedingly kind and hospitable to Lieut. Grandy and his party, and had promised facilities for future expeditions. He had found several traces of the Portuguese occupation of Congo, and he described the natives as being civilised, indolent, and exceedingly fond of snuff and tobacco. The palm-tree grew abundantly, but the principal use made of it by the natives was the distillation of the oil into a very intoxicating wine, in the use of which

the king and chiefs indulged rather freely. Lieut. Granly had shown his Majesty specimens of stearine, and he promised to commence its manufacture, instead of wine, from his palm oil. A terrible epidemic of small-pox was decimating Congo as Lieut. Granly travelled through the country, and it almost entirely carried off his native porters and escort. In conclusion, the report described the Congo as being one of the grandest rivers in the world, and as being navigable for a distance of 110 miles from its mouth.

## CAMBRIDGE

**Philosophical Society, Nov. 30.**—Prof. Humphry in the chair.—A paper on "Lopsided Generations," or "Right-handedness," by Dr. W. Ainslie Hollis, was read, which, judging from the abstract before us, contained little or no new matter. The author laid special stress on the statement that the left side of the brain in man is the larger, and that aphasia is connected with disease of that side; statements which, in the discussion which followed, Prof. Paget justly remarked were not yet in any way proved. The cases of Johnson and Swift were quoted as instances in which the left side of the brain had suffered, and paralysis of the right side had been induced, apparently as a consequence of overwork. Prof. Humphry and Mr. Carver both agreed that right-handedness was much a matter of education.—Dr. Wilson made a communication on the disposition of the peritoneum in man and other vertebrata, directing special attention to the peculiarities of the omental sac, which he showed to be frequently divided into two parts—a gastro-hepatic and a gastro-colic—by a constriction corresponding with the upper border of the stomach. One or more of the hepatic lobes usually project into the gastro-hepatic portion of the sac. In man, and we should therefore expect in others, it is the lobulus sigmoideus.

## DUBLIN

**Royal Irish Academy, Nov. 9.**—William Stokes, F.R.S., president, in the chair.—Samuel Ferguson, V.P., read a paper on the Ogham-inscribed stone at Montaggart, Co. Cork. The author, in applying to this text, which had been considered undecipherable, the same method of translation adopted by the present Bishop of Limerick in the case of the Camp inscription, read it "Feqreq Moqoi Glunleget," identifying Feqreq with the name Feachra, as written by Adamnan, and assigning the meaning of "the kneeler" to Glunleget, which he took to be a name in religion; and expressed his belief that the monument is Christian.—A letter was read by the Secretary from Mr. R. R. Brash, commenting on Dr. Ferguson's paper.—Mr. H. W. Mackintosh read a paper on the muscular anatomy of *Cholopus didactylus*.—Alexander Macalister, M.D., read a paper on two new species of Pentastoma. The first of these, *P. imperatoris*, was found in the lung and peritoneal cavity of *Bov imperator*, from South America; the second, *P. aonyxii*, in the peritoneal cavity of *Aonyx leptonyx*, var. *B. major*, from the River Indus.—Alexander Macalister, M.D., also read a paper on the presence of a lachrymo-jugal suture in a human skull. Although the relation of the maxillary process of the jugal bone to the supra-orbital edge of the maxilla is subject to a considerable amount of variation, yet in the majority of cases this process ends at a point vertically over the infra-orbital foramen. But in one skull in the collection of Trinity College, Dublin, of which the history is unknown, the author found the maxillary process to stretch over the whole infra-orbital edge of the maxilla, in front of the large external hamulus of the lachrymal bone, with which it forms a suture of about a line and a half in length. The author further gives a sketch of the comparative anatomy of this suture.

## PARIS

**Geographical Society, Dec. 2.**—President, M. Delesse.—Dr. Cosson declared himself decidedly against the scheme of forming a sea in the interior of Africa, on the site of the Tunisian "Chotts." He believes that not only would the climate of the Sahara be modified, but the great source of wealth of these regions—the culture of dates—would be completely destroyed. Moreover, the commercial results would never repay the enormous cost, estimated at about 12,000,000*l.* for Tunis, and a like sum for France. All the existing legitimate commerce is sufficiently carried on by means of caravans. It was, however, suggested that it would be wise to suspend judgment on the subject until the return of the French expedition, which is making preliminary investigations on the spot.—Dr. Hamy announced the discovery of new mines of gold in Australia, and of very ancient caverns which are expected to yield valuable results to geologists.—Dr.

Harmand, one of the companions of the unfortunate Lt. Garnier, gave many interesting details concerning Tonquin.

**Academy of Sciences, Dec. 7.**—M. Frémy in the chair.—The following papers were read:—Memoir on the actions produced by the simultaneous concurrence of the currents from a battery and electro-capillary currents, by M. Becquerel.—Memoir on the intervention of physico-chemical forces in the phenomena of life, by M. Becquerel.—On the capillary theory according to the Liliaceae (*Yucca*), by M. A. Trécul.—On the swim-bladder from the point of view of station and locomotion, by M. A. Moreau.—Note on magnetism, by M. J. M. Gauguain.—On trials at acclimating the "Jesuit's-bark" tree in the Isle of Réunion, by M. Vinson.—On the ureides of pyruvic acid; synthesis of a homologue of allantoin, by M. Grimaux. In the present communication the author has examined the derivative obtained by the action of urea upon pyruvic acid. This body, named by its discoverer *pyruvite*, is a white crystalline substance of the formula  $C_5H_8N_2O_5$ . Treated with hydrochloric acid, it is converted into mono-pyruvic ureide,  $CON_2H_2(C_2H_3O)$ .—Application of illuminating gas to the pyrophone, by M. F. Kastner. The author's experiments show that if two or several isolated gas flames of convenient size are introduced into a tube of glass or other material at a distance of one-third of the length of the tube, reckoned from the lower extremity, these flames vibrate in unison, this phenomenon continuing as long as the flames remain separated, but ceasing immediately on their being brought into contact. The author likewise verifies the formation of ozone in the tubes.—Observations concerning species of the genus *Phylloxera*, by M. Signoret. The author publishes the following rectified synonymy:—*P. corticis*, Kalténb. = *Lichtensteinii*, Balbiani = *Rileyii*, Lieb. MSS. Riley.—Method followed in searching for the most efficacious substance to oppose to *Phylloxera* at the viticultural station of Cognac, by M. Max Cornu.—Despatch from M. Stéphan, director of the Observatory of Marseilles. This refers to the discovery on the 6–7 December of a new comet by M. Borrelly.—Occultation of Venus, eclipse of the sun and of the moon, observed during the month of October at Paris, by M. C. Flammarion.—Solution of the equation of the third degree by means of a jointed system, by M. Saint-Loup.—On two simple laws of the active resistance of solids, by M. J. Boussinesq.—Determination of the analytical relations which exist between the elements of curvature of the two *nappes* of the evolute of a surface, by M. A. Mannheim.—On the solutions of chrome alum, by M. D. Gernez.—On the transformations of persulphoyanogen, by M. J. Ponnareff. Phosphoric chloride appears from the author's researches to have the following action:—

$$C_3N_3S_3H + 3PCl_5 = 2PCl_3 + S_2Cl_2 + PSCl_3 + HCl + C_3N_3Cl_3$$

The action of ammonia has also been studied.—On the transport and inoculation of virus, caruncular and others, by flies, by M. J. P. Mégnin. The author considers it demonstrated that certain flies, such as *Stomoxys*, &c., can be agents of transmission of certain virulent maladies—amongst others carbuncle.—During the meeting the perpetual secretary announced to the Academy that they had sustained a heavy loss in the person of Count Jaubert.

## CONTENTS

	PAGE
THE TRANSIT OF VENUS . . . . .	121
CHAPPELL'S "HISTORY OF MUSIC" . . . . .	123
FOSTER AND BALFOUR'S "EMBRYOLOGY" . . . . .	126
OUR BOOK SHELF . . . . .	128
LETTERS TO THE EDITOR:—	
The Royal Agricultural Society and the Potato Disease.—Prof. W. T. THISTLETON DYER . . . . .	128
Sensitive Flames.—Prof. W. F. BARRETT . . . . .	129
Fossils in "Trap."—Dr. D. HONEYMAN . . . . .	129
THE RELATION OF RACE TO SPECIES. By EDWARD B. TYLOR, F.R.S. ( <i>With Illustrations</i> ) . . . . .	129
TRANSIT OF VENUS. By Lieut.-Col. A. STRANGE, F.R.S. . . . .	130
PRACTICAL SCIENCE AT CAMBRIDGE. By G. T. BETTANY, B.A. B.Sc. . . . .	132
M. BECQUEREL ON SOLAR PHYSICS . . . . .	133
REAPPEARANCE OF ENCKER'S COMET. By J. R. HIND, F.R.S. . . . .	134
NOTES . . . . .	134
ON THE STRUCTURE OF STIGMARIA. By Prof. W. C. WILLIAMSON, F.R.S. . . . .	136
VEGETATION OF THE LIBYAN DESERT . . . . .	137
SCIENTIFIC SERIALS . . . . .	138
SOCIETIES AND ACADEMIES . . . . .	138

THURSDAY, DECEMBER 24, 1874

## PROTECTION FOR INVENTIONS

THAT most active and practical body, the Society of Arts, persevering in its endeavours to place our Patent system on an efficient footing, has devoted four evenings to the discussion of the question, the debate being led off by Mr. F. J. Bramwell, C.E., F.R.S., in a paper the ability of which has been warmly and justly extolled on all sides, alike by opponents and supporters, without a dissentient voice.

Mr. Bramwell, being circumscribed by the narrow limits of a short address, confined his attention principally to the question whether or not patents should be abolished. He probably foresaw that the discussion thus provoked would cover wider ground and examine the further question whether the system of patents, if preserved, does not admit of improvement. And it accordingly turned out so, for the latter question was much more fully discussed than the former.

The unanimity of opinion, indeed, as to the expediency of continuing to grant patents for inventions was most remarkable, the principal, if not the only dissentient, being Mr. John Horatio Lloyd, Q.C. This eminent legal authority, who in his evidence before the Parliamentary Committee urged the abolition of patents, now came forward, it is true, to declare that his opinions had undergone a change, and "expressed a reluctant acquiescence, though not a settled conviction, as to the expediency of protection for patents;" and he may therefore object to be ranked amongst the dissentients. We must refer to his speech as our justification for so placing him. This speech may be commended to metaphysicians, as throwing great light on the question whether the soul and the mind of man are distinct and separate. Mr. Lloyd's soul evidently hateth patents, but his mind perceives their necessity. His mind is only permitted to admit this necessity in the brief sentence we have quoted, and his soul then for the space of an hour employs every artifice of rhetoric to prove that the mind's admission is unwarrantable and unsound. In no other way can the discrepancy between the arguments and the conclusions be explained. It is impossible that they can both emanate from one and the same mind, and that an unusually acute mind. They issue, obviously, from two distinct and indeed antagonistic sources. It is not often that the spectacle is afforded us of a good and able man the helpless sport of a psychological contest. Mr. Lloyd's speech settled the main question. Skillful though it was, and delivered with the gentlemanly grace natural to him, the meeting was against him to a man, and listened to him, latterly, even with impatience. After he sat down, no one attempted the task, in which he had so signally failed, of proving that patents are injurious to the community, and, assuming them to be abolished, of providing an effective substitute.

The discussion then turned chiefly on the defects of the present English system and on the peculiar features of some foreign ones, particularly that of the United States, which was alternately approved and condemned. And here, as in mixed assemblages of Englishmen generally, there was much running after details, much reliance on

illustrations, and but a small modicum of broad and systematic treatment. The point principally dwelt on was the necessity for a preliminary examination of patents. This, two members of Parliament—Mr. Hinde Palmer, Q.C., and Mr. Samuelson—informed the meeting, had been recommended by a Committee of the House of Commons on which both speakers had sat; but though some years had elapsed, no steps had been taken in the matter. Col. Strange caused a sensation by stating that the Patent Commissioners had applied to the Council of the Royal Society to nominate one of three eminent men of science who should perform this herculean task without salary, and that that learned body had, much to its credit, scouted the idea. This elicited strong expressions of opinion on the absurdity, injustice, and inexpediency of grudging to scientific men alone, of all those whose labours directly benefit the community, the liberal remuneration to which they are entitled. We have more than once brought this question before our readers, as one of those on which views are held in some quarters having a most prejudicial effect on those scientific reforms which are so urgently needed in England. We have never urged the proper remuneration of scientific labour on the grounds of mere philanthropic liberality to the labourer, but on the much higher ground that it is for the benefit of the nation materially, not less than for that of knowledge, that prospects should be held out of a career to those possessing talents and tastes for scientific pursuits. At present no profession, scarcely any occupation, holds out such small inducements to the rising generation of educated Englishmen as science. It needs no argument to prove that this passive discouragement of one of the spheres of intellectual activity most fruitful of advantages to mankind must have very injurious results, as we know from every-day experience that it has. We are glad to find that Mr. Bramwell, in his masterly summing up of the debate, ranged himself vigorously on our side of this important question; and it was with pain that we noticed expressions in the contrary sense, dropped, we trust inadvertently, by Mr. Samuelson, who, as a member of the Duke of Devonshire's Science Commission, must be well aware how much science suffers by the narrow neglect with which, as a nation, we treat the investigators of nature.

But to return to the question of a preliminary examination of patents.

There was some difference of opinion, though not of an irreconcilable nature, as to the expediency of this measure. It was too much assumed, even by Mr. Bramwell himself, that if such an examination were established here, it would necessarily be conducted in the same manner and with the same objects as in America—a perfectly gratuitous assumption. In America patents are examined mainly for novelty and utility, and are often rejected for failure in either respect. It is apprehended that, since inventors are often in advance of their age, an indiscriminate exercise of the power of rejection may retard the introduction of useful improvements—and several alleged instances of this were adduced. It is not always safe, however, to argue by illustration alone. The illustration may be inaccurately stated or wrongly applied, as in the case of one of those cited by Mr. Cole, who said that the power of rejection "would have prevented the building of the Crystal Palace, which wise men said must



inevitably be blown down." The speaker no doubt had before his mind an imperfect recollection of the discussion which followed the reading of Mr. (now Sir Digby) Wyatt's paper on the first Great Exhibition building at the Institute of Civil Engineers in January 1851, when one "wise man," the present Astronomer Royal, objected to so purely rectangular a structure of iron, and insisted on the necessity for adding diagonal braces, giving at the time a full demonstration of his views. The question was one of Elementary Mechanics, which should have been better understood than it seems to have been. The "wise man" was right, as is proved by the adoption of his suggestion in the construction of the Crystal Palace; and his dictum, so far from retarding or preventing its erection, has probably saved that and similar structures from a hideous catastrophe. This is an instance of a wrongly applied illustration telling strongly against the argument it was intended to enforce. The power of rejecting patents is one, however, which, we fully admit, if conceded at all, should have its limitations, and should be exercised exceptionally rather than generally. But the staff which, under the American system, exercises this power, as some think too freely, is still indispensable for other purposes, as pointed out by Mr. Bramwell in his concluding address. They should, as a matter of duty, be ready and able to afford to inventors the fullest information, and should render them all reasonable assistance in steering clear of those shoals which must surround any patenting system. They should do this, not merely out of kindness to ignorant though ingenious inventors, but on behalf of the community, whose interest it is that a really useful improvement should be introduced in the most perfect possible shape. They should also revise specifications, which, often in ignorance, and sometimes from motives of questionable honesty, vaguely, imperfectly, or incorrectly set forth the invention. They would also sit with the judges on the trial of patent cases, affording that technical and scientific knowledge of the matters at issue in which it is admitted that both the Bar and the Bench are deficient.

In the consideration of this most important question, one of the uses of a well-organised patent system has hitherto been too little noticed—namely, that it may be made, both directly and indirectly, a powerful instrument of public instruction. A body of highly qualified responsible men, eminent in different departments of science and technology, acting in concert, and having at their command the resources and influences of a great department founded specially for introducing material improvements, including a complete collection of all the machines and appliances of manufacturing industry, and all the instruments and apparatus used in both abstract and applied science, which they should explain in public lectures, could not fail to disseminate widely that peculiar class of knowledge which it is found so difficult to engraft on any ordinary educational system.

Nor is this the only important point that entirely escaped notice in the recent discussion. The present constitution itself of the Patent Office was not challenged. It seemed to be considered that this having been, not very long ago, settled by a Committee of the House of Commons and an Act of Parliament, must be taken for granted as inevitable and unassailable. But fifty com-

mittees and acts of the Legislature should not suffice to preserve a constitution so inherently bad. What is it? The Patent Office is governed by four commissioners, the Lord Chancellor, the Attorney-General and the Solicitor-General for the time being, and the Master of the Rolls. Of these four, not one is presumably qualified by special knowledge, and three out of the four are liable to change frequently with changes of the Ministry. Nor is it even expected that any one of the four can or will give a moment of his time to Patent Office duties. The late Lord Chancellor candidly avowed to a deputation of the Society of Arts that he had never once entered the Patent Museum. The Master of the Rolls presides over perhaps the hardest worked court in the kingdom. And the two law officers, besides their duties as advisers to the Crown, are encumbered with their still more exacting duties to themselves as barristers in large practice. Notoriously and avowedly these four high legal functionaries leave the Patent Office to the care of its clerical staff. Should so monstrous an abuse be suffered to continue? Is it possible that, whilst it continues, necessary reforms will be introduced and efficient administration maintained? Nothing is more obstructive and more demoralising than a sham—and no worse or more glaring sham than this exists at the present day in a country in which shams are not very few or very retiring. The remedy is perfectly obvious. The Patent Office should be under a Minister of the Crown, directly responsible to the nation through Parliament for its good government. The Society of Arts have been for some time most properly urging that the Patent Museum, considerably expanded, should be placed under a Minister, with other Museums. Surely they cannot contemplate such a disruption of the whole system as would be perpetrated by placing the Museum under one authority, and the office to which it is an adjunct under another. We trust therefore they will insist that the whole system should be ministerially governed. For the present we abstain from indicating the particular Minister who should have charge of this and similar institutions, not because the appropriate arrangement is at all doubtful, but because our space to-day does not admit of our delineating it with the necessary fulness.

In conclusion, we hope that the unanimity in the late debate and in the press, in favour of retaining Patent Laws, will silence effectually the feeble cry for their abolition which from time to time contrives to make itself heard. No one can now, at any rate, be considered qualified to raise that question who has not read this discussion, and especially Mr. Bramwell's two closely reasoned masterly addresses.

#### LIVINGSTONE'S "LAST JOURNALS"

*The Last Journals of David Livingstone in Central Africa, from 1865 to his Death. Continued by a Narrative of his last moments and sufferings, obtained from his faithful servants, Chuma and Susi. By Horace Waller, F.R.G.S., Rector of Twywell, Northampton. In two vols. With portrait, maps, and illustrations. (London: John Murray, 1874.)*

THE opinion which we expressed of Dr. Livingstone's character and of the value of his work, when the sad tidings of his death reached this country last spring,



is amply confirmed by the simple narrative before us. No one, we presume, who knows the work that Livingstone has done, and how he has done it, will hesitate to place him in the front rank of explorers, and award him a niche among the few whom men deem worthy of the highest and most enduring honour. It is, we believe, the simple truth to say that he has done more than any other man to fill up that vast blank in inner Africa which in the maps of twenty or thirty years ago was occupied only by the word "Unexplored" in large and widespread letters, delightful enough to the hearts of lazy schoolboys. Now, what with the labours of Livingstone in the south, and those of Baker, Burton, Speke, Grant, and others in the north and north-east, this blank space is reduced to a comparatively small circle around the equator on the 20th degree of east longitude. We have no doubt that within the space of the next twenty years, or less, the heart of Africa will be as fully and accurately mapped as that of South America, if indeed not more so. And when the geography of this region of the earth is complete; when science shall have been enriched with the knowledge of its multitudinous products organic and inorganic, when a legitimate commerce shall have brought its many blessings to the native population, who seem possessed of many capabilities for good; when Central Africa shall have taken its place among the civilised nations of the world—the memory of David Livingstone will be cherished by its peoples as worthy of the greatest reverence and gratitude. It will be long ere the tradition of his sojourn dies out among the native tribes, who, almost without exception, treated Livingstone as if he were a superior being; indeed, had it not been for the baneful influence of the Arab slave-traders, and the troubles which arose from the debased characters of the majority of his own retinue, Livingstone's last journey would have been one of comparative ease, would have been accomplished probably in about half the time, might possibly have been even more fruitful in results than it has been, and, above all, he himself might now have been among us, receiving the honours which he so nobly won.

As it is, we are thankful for the grand results that Livingstone has left behind him, which he achieved in the face of difficulties that would have daunted almost any other man, and which in the end brought himself to death; thankful are we also to the brave and loyal Susi and Chama, who stuck so faithfully to their master, and preserved so religiously the invaluable record of his achievements. Their conduct has won for them the admiration of the civilised world, and their care for their master's remains has earned for them the gratitude of all Englishmen.

If this record of Livingstone's last wanderings is a sad one, it is not on account of any wallings that escape from the traveller himself. His journals were faithfully kept day after day, but the entries in them are brief, though pregnant. He wastes no useless words on his sufferings; nearly every sentence is a statement of an observed fact. Indeed, he distinctly says, when his difficulties began—and they began at the beginning—that he looked upon all his troubles as necessarily incident to the work he had set himself to do, and to be taken no more account of than the little difficulties which everyone must look for in carrying out his work in the world. Like all really great men,

he did his work and made no fuss about it. Until near the end, when his sufferings must have been extreme, nothing like the cry of an afflicted man escaped him; his difficulties of all kinds were regarded merely as hindrances to the great work [which he was so anxious to achieve. His journal is written in the simplest style, and never betrays any consciousness on his part that he was doing anything very extraordinary. His was no attempt to accomplish a mere traveller's feat; he had a definite task before him—the exploration of the lake region of Central Africa, a task which he never once lost sight of. True, in the end, his work concentrated itself on the discovery of the four fountains of Herodotus, which he expected to find away to the west of Lake Bangweolo, and among which he firmly believed he would find the long-sought-for source of the Nile. It was on the road to these supposed fountains that he died; had he lived to discover them or to disprove their existence, he would have considered his work as an explorer at an end, and would have returned to spend his remaining days at rest among his friends.

Livingstone's theories as to the sources of the Nile may very possibly turn out to be mistaken; but this can in no way detract from the value of his work. The "Nile mystery" cannot now long remain unravelled; but, compared with the large and substantial achievements of Livingstone, the solution of this is little more than that of an ingenious puzzle. Under all circumstances, Livingstone must ever stand forth as one of the world's greatest explorers, not only on account of his own immediate discoveries, but on account of the impetus which he has given to African discovery; for it is mainly owing to the enthusiasm generated by his noble example that so much has been done during the last thirty years to fill up the great blank on the map of Africa. His own travels, extending over a period of thirty years, embraced an area of some millions of square miles, reaching from the Cape to within a few degrees of the equator, and from the mouth of the Zambesi to Loango. And, as we have said, his aim was not to get over so much ground in the shortest possible time, and return to reap the reward of his feat. Like the native Africans, he travelled slowly and leisurely by short stages, mainly on foot, carefully and minutely observing and recording all that was worthy of note in the natural productions and phenomena of the region over which he travelled, studying the ways of the people, eating their food, living in their huts, and sympathising with their sorrows and joys. Already have various departments of science been enriched by his observations; and, what is perhaps of more importance, he has shown that in Africa a fertile field remains for the minute observations of the trained naturalist, ethnologist, geologist, and meteorologist.

It is impossible in the space at our disposal to give any adequate idea of the results of his last seven years' journeys. Indeed, as we have said, the records in his journals are so terse, there is so little of what is superfluous and so much of the highest value, that anyone wishing to have a satisfactory notion of what he accomplished must go to the work itself. Mr. Waller has wisely printed the journal as he found it, making no attempt at a systematic arrangement of the material; this will, no doubt, be done gradually, and the observations

which he made day by day take their place in the various sciences to which they belong. We are glad to see from the preface that there still remains for future publication a valuable mass of scientific observations. "When one sees," to quote the preface, "that a register of the daily rainfall was kept throughout, that the temperature was continually recorded, and that barometrical and hypso-metrical observations were made with unflinching thoroughness of purpose year in and year out, it is obvious that an accumulated mass of information remains for the meteorologist to deal with separately, which alone must engross many months of labour." We hope that no time will be lost in giving the world the benefit of this valuable material.

We shall briefly run over the ground traversed by Livingstone. He left Zanzibar on March 19, 1866, in the

*Penguin* for the mouth of the Rovuma in about  $10\frac{1}{2}$  S. latitude. His company consisted of thirteen sepoy, ten Johanna men, nine Nassick (Bombay) boys, two Shapanga men, and two Wayaus (South Africans), Wekatani and Chuma. He had, besides, six camels, three buffaloes and a calf, two mules, and four donkeys. This seems an imposing outfit, and so it was, but it soon melted away to four or five boys. Rovuma Bay was reached on March 22, and a start for the interior was made on April 4. His course for the first three months was mainly along the banks of the river Rovuma, turning south-west after a march of about 300 miles, towards the south end of his own Lake Nyassa. On starting he has recorded some reflections on the advantages of travelling, which, for their own value and as giving an insight into the character of the man, we wish we had space to quote. The first part of his



A Fish-Eagle on a Hippopotamus Trap.

course was through a dense jungle, and here the botanist will find some observations worthy of his attention. The gum-copal tree is here in great abundance, and some curious geological phenomena are noted. Ere he reached the Nyassa he had to send his sepoys back, as they were worse than useless; a set of lazy, degraded blackguards, whose brutal usage of the animals and that of the Johanna men, left him in the end with only his goats and a little dog. The Johanna men, ere they were well round the end of the lake, deserted,\* and Livingstone was no doubt well rid of them, though it left him with so diminished a retinue that it made him dependent on native carriers, who were often

\* It will be remembered that these men screened their cowardice by spreading a report of Livingstone's death.

difficult and expensive to procure. However, this was an evil that gradually lessened as he went on; for as he conscientiously paid his way wherever he went, his baggage was gradually diminished to no great bulk. In the first part of the route, also, the party frequently suffered from want of food, an evil which was of but too frequent occurrence during the long and intricate journey, not so much from unwillingness on the part of the natives to give or sell it, but simply because the brutal half-caste Arab slave-dealers, who were met with everywhere, had so desolated the country that the terrified and demoralised people were often themselves famishing. The horrors of this trade, "the open sore of the world," as Livingstone calls it, are shown on almost every page of this journal, and one of the sorest trials which the humane traveller had to endure

was to be an almost daily witness of its inconceivable cruelties, and to feel himself powerless to help. Even in this matter, however, we believe his words and example will have had a good moral effect on many of the native chiefs, if not on the degraded dealers; for the people are so demoralised by the latter, that they hunt and sell each other. This Arab slave-hunting was a great hindrance to Livingstone's progress, as the dealers had so terrified the people as to make them suspicious of every stranger, and, with one or two creditable exceptions, did all in their power to poison the native mind against the white man, for they knew that he regarded their doings with unmitigated disgust. No good can come to Africa, and no exploration of her rich interior can be carried out with complete success, until this cruel traffic is abolished; and in the interests of science as well as humanity, we hope that the British Government will never cease to use its powerful influence until it is stamped out. We only wish that the Sultan of Zanzibar, whose subjects the half-caste traders nearly all are, could be induced to follow the example of the Khedive of Egypt, and depute some man of determination and vigour to sweep the interior of the entire horde of slave-hunters.

And here we cannot help saying that we almost wish that Livingstone had possessed some of Pasha Baker's wholesome sternness and disregard to the trivial scruples of his men and of petty village chiefs. It would have saved him many annoyances, and might in the end have been the means of saving his life. But he was so full of the great object of his mission that he did not care to waste the time and energy required to bring his low-minded sepoys and Johanna men under discipline; and his conscience was so tender, his humanity so strong, and his desire to live at peace with all men so much of a religion, that he would rather stay weeks at a village to suit the caprice of its childish chief than break away at the risk of giving offence or provoking hostility. His genuine tenderness of heart peeps out unconsciously every now and then, his charity was wonderfully wide, and his forbearance often almost annoying.

Lake Nyassa was reached on August 8, and passing down its east and round its south side, Livingstone struck out in a generally N.N.W. direction for the south end of Lake Tanganyika. We need scarcely say that this part of the journal, recording a journey through a country much of which had not hitherto been explored, is full of valuable notes on geology, botany, zoology, geography, topography, and the manners and customs and connections of the people. Here, as in almost every other part of his journey, the number of streams met with flowing into the great lines of drainage is astonishing; a dozen would sometimes have to be crossed in a day's march. After rounding the south end of Nyassa, however, he first met with those bogs, or earthen sponges, which abound also around Lake Bangweolo, and in the midst of which, and no doubt partly through their malarious influence, he died.

"The bogs, or earthen sponges, of the country," he says, "occupy a most important part in its physical geography, and probably explain the annual inundation of the rivers. Wherever a plain sloping towards a narrow opening in hills or higher grounds exists, there we have the conditions requisite for the formation of an African sponge. The vegetation not being of a healthy and peat-

forming kind, falls down, rots, and then forms thick dark loam. In many cases a mass of this loam, two or three feet thick, rests on a bed of pure river-sand, which is revealed by crabs and other aquatic animals bringing it to the surface. At present, in the dry season, the black loam cracked in all directions, and the cracks are often as much as three inches wide, and very deep. The whole surface has now fallen down, and rests on the sand; but when the rains come, the first supply is nearly all absorbed in the sand. The black loam forms soft slush, and floats on the sand. The narrow opening prevents it from moving off in a landslip, but an oozing spring rises at that spot. All the pools in the lower portion of this spring-course are filled by the first rains, which happen south of the equator, when the sun goes vertically over any spot. The second, or greater rains, happen in his course north again, when, all the bogs and river-courses being wet, the supply runs off, and forms the inundation: this was certainly the case as observed on the Zambesi and Shiré, and, taking the different times for the sun's passage north of the equator, it explains the inundation of the Nile."

This is an important observation with regard to the Nile, though it may very well turn out that Livingstone himself was mistaken with regard to its source or sources. He found, as we have said, the same phenomenon in a much higher degree on the east and south sides of Lake Bangweolo, and believed it to be "the Nile, apparently enacting its inundations, even at its sources."

We wish we could linger with the traveller and speak in detail of some of the multitude of interesting observations he made as he sauntered along. The people themselves between Nyassa and Tanganyika are full of interest to the ethnologist, the sociologist, and the student of the ways of men. Their physique and intelligence are of a high order, and they have scarcely any of the negro characteristics. They are by no means savages, and in almost every village Livingstone was well and kindly treated by the chief and his people. There is no such thing as a national bond of union here, each village being a separate community, presided over by its chief. The region here, as every where else in Livingstone's journey, is thickly populated. The people are polite, industrious, and on the whole peaceful, the great disturbers of their peace being the Mazitu, a people to the north of Nyassa, who rove far and wide in search of slaves, leaving death and desolation in their track. The great industry here, and over a great part of the region visited by Livingstone, is the smelting and manufacture of iron, which is obtained in abundance from various ores. In this industry the people display considerable skill and ingenuity, and manufacture the metal into a great variety of implements, utensils, and weapons. Each tribe has its separate tattoo badge. The country itself, hilly, and well wooded, is of the most fertile kind, and abounds in buffaloes, elands, haartebeest, and other large animals, and evidently with not a few birds that are new to the zoologist.

(To be continued.)

#### INDIAN METEOROLOGY

*Report of the Meteorological Reporter to the Government of Bengal for 1873.* By Henry F. Blanford, Meteorological Reporter.

MR. HENRY F. BLANFORD'S annual Meteorological Reports for Bengal, of which this is the seventh, have come to be looked forward to with much

interest by meteorologists, as not only model monograms of the subject discussed by them, but as further developing and occasionally opening up certain lines of inquiry which lead to practical applications of the science. In these respects the Report for 1873 is the best, as well as the most suggestive. Its outstanding feature is the discussion of the deficient rainfall of the Presidency during 1873, so disastrous by the famine which followed it; and the developing in the course of the discussion of a principle which, if confirmed by future observations, "will enable us to some extent to forecast our [Indian] seasons, or at least to speak with some confidence to their probable character for some months in advance."

From the increased number of stations now in connection with the department, and from the additional data obtained from the meteorological superintendents of the Governments of Ceylon, the Upper Provinces, Central India, and Berar, it is possible to form a conception of the geographical distribution of pressure, temperature, rain, &c., over one-half of India and its seas. The summaries of all the observations made over the region during the past seven years form an admirable feature of the Report. We very cordially join in the hope expressed that the observations which have been made in the Presidencies of Bombay and Madras will in future be accessible, and that those made in the Punjab will be put on such a footing as to be trustworthy and comparable. As regards the last-named region, in all the annual reports we have seen (down to 1870) the barometric observations are given uncorrected for temperature and unaccompanied with the readings of the attached thermometer! When, on making the annual survey of the meteorology of India, the north-west, west, and south of the country can be included, it will be possible to write the history of the two monsoons of the year, and probably to point out the determining causes of their irregularities.

"The principal meteorological characteristics of the year 1873 were an excessive temperature, in Oude and the North-western Provinces more especially; an unusually low pressure of the atmosphere in the same region, and probably also in the south-east corner of the Bay of Bengal, while in Eastern Bengal pressure was persistently high; great unsteadiness in the winds, indicating the predominance of local causes in affecting the air currents, while the normal monsoon current from the south-west set in nearly a month later than usual, and ceased nearly a month earlier; lastly, a general deficiency of moisture in the atmosphere, as is betokened both by the hygrometric observations, the comparative absence of cloud, and the great deficiency of rainfall."

The usual characteristics of the Indian summer monsoon, based on the past seven years' observations, are thus stated:—

"In ordinary years the winds of the south-west monsoon blow, on the one hand from the Arabian Sea, on the other hand from the Bay of Bengal towards a line lying to the south of the Ganges, at no great distance, and parallel to that river. A barometric depression begins to appear in or near this region in April, and by the time the rains set in in June it is well established; the pressure decreasing along it from east to west where this trough, as it may be termed, merges in the great barometric depression of the Punjab and the Bikaner Desert. To the south of this line the winds from the Arabian Sea blow across the Central Provinces, chiefly from the west. To the north of it, those from the Bay of Bengal, turning

with the Gangetic Valley, blow in an opposite, or easterly, direction, their line of meeting being along this trough."

Bengal being thus dependent, as regards its rainfall, on the aerial current which blows from the Bay of Bengal up the valley of the Ganges, it is evident that whatever weakens this current or directs it to the northward will have a serious influence on the rainfall. Now, in 1873 the trough described above did not occupy the usual position to the south of the Ganges, but a position considerably to the north-west, in Oude and Rohilcund, immediately under the hills. A change in the direction of the wind necessarily followed this change in the position of the area of lowest atmospheric pressure; and in strict accordance with the now well-known relation of wind to pressure, there was an unusual prevalence of westerly winds over the greater part of Bengal during June and July, and the rainfall consequently was deficient.

The observations made in the Andaman and Nicobar Islands show the existence of a barometric depression over the south-eastern portion of the Bay of Bengal, the effect of which would be to deflect a large portion of the monsoon current of the Bay of Bengal towards Sumatra and the Tenasserim and Burmah coasts. Thus, then, the monsoon current, on which Bengal is dependent for its rainfall, was not only deflected northward from its usual track during 1873, but was also weakened in force by being partially drained away to the south-east in the direction of Burmah.

In the examination of the rainy seasons of 1868, 1869, and 1873, Mr. Blanford has the merit of first drawing attention to the existence of local and persistent variations of pressure, which appear as a local exaggeration or partial suppression of the great annual variation—the pressure remaining for many months, sometimes through two or more consecutive seasons, either higher or lower than the average, relatively to other parts of the country, over a more or less extensive track. It is to these persistent irregularities in the distribution of atmospheric pressure that the irregularities in the distribution of the rainfall must be ascribed, and it is to the further investigation, by future observations, of the characteristic feature of persistency in this class of barometric variations that we look with hope to the realisation of a great triumph awaiting meteorology, viz., the prediction, for some months in advance, of the general character of the coming seasons of India, and thereafter a gradual extension of the principle to other countries.

As regards the humidity, the only data of observation published in the Report are the dry-bulb observations. To these are added the *computed* values for the elastic force of vapour and the relative humidity. In future issues of the Reports we should recommend that the wet-bulb observations be also published. In a country of such extreme climates as India, it is eminently desirable to have the whole *observed facts* relative to the humidity before us, particularly since, from the present defective state of our hygrometric tables as regards dry hot climates, computed values can be regarded only as rough approximations. In estimating the state of the sky, a clear sky is entered as 10, and a sky completely covered with cloud as 0. It might be well in future to adopt the recommendation of the Vienna Meteorological Congress on this head, by which a clear sky is

entered as 0, and a sky completely covered with cloud as 10. The number of days at the various stations at which "a measurable quantity of rain fell," are given in Table xxx. The exact amount of rain constituting a rainy day should in future be stated. In Great Britain only those days on which at least 0.01 inch falls are regarded as "rainy days." We are glad to see that Symons' gauges (5-in. diam.) are adopted—this being the gauge best suited for general introduction—and that the height is a foot above the ground.

We have long been convinced that for a first satisfactory scientific discussion of some of the more difficult problems of the science we must look for the data of observation to India, with its splendid variety of climates, exposures, and abrupt mountain ranges and isolated peaks. The chief of these questions are, the variations in the daily march of temperature as dependent on season, latitude, height, and situation, both maritime and inland; the hourly barometric fluctuations (of which so little is really known), particularly as influenced by strong insolation, vapour, cloud, aqueous precipitation, and height either on extended plateaus or on hills rising abruptly from the plains; and the vital question of atmospheric humidity, to put which on a proper footing as regards hot dry climates, laboratory experiments being all but worthless, recourse must be had to extensive observations and experiments conducted under such conditions as are presented by the scorching climate of the Punjab. In the further development of Indian and general meteorology, the establishment of a Physical Observatory in the Punjab is urgently called for, as being, in truth, indispensable for the prosecution of these and other physical researches.

#### OUR BOOK SHELF

*A Year's Botany, adapted to Home and School Use.* By Frances Anna Kitchener. Illustrated by the Author. (Rivingtons: London, Oxford, and Cambridge, 1874.)

THIS unpretending little book is one that is sure to find its way wherever Natural Science is taught in the only way in which it is worth teaching, as a training for both the observing powers and the reasoning faculties. The greater part appeared originally in the *Monthly Packet*, and has been reprinted with additions at the request of friends more discriminating than is usually the case under such circumstances. We know of no book which we could more safely and confidently place in the hands of young people as their first guide to a knowledge of botany. The illustrations are from drawings from nature by the authoress, and are a pleasing change from those which have already done duty in so many text-books.

The following sentence, from the first chapter, illustrates the mode in which the writer conveys her instruction:—"But first I must beg that my readers will give me a fair trial; that they will pick the flowers described, and examine them *while* they read the description; and that they will trace every law, arrangement, and peculiarity in their living illustrations. Sometimes these may not be seen at the first glance, or even in the first specimen, but they must pick fresh flowers, look and look again, and *take nothing upon trust*, remembering that one of the chief lessons botany has to teach is how to use both eye and hand." Several typical flowers are then taken—the buttercup, wall-flower, cucumber or vegetable marrow, gorse, garden-pea, and primrose, and the various parts of each described in ordinary language, without the use of any technical terms. To these succeed separate chapters

"On Flowers with Simple Pistils," "On Flowers with Compound Pistils," "On Flowers with Apocarpous Fruits," "On Flowers with Syncarpous Fruits," and "On Stamens and the Morphology of Branches." To each chapter is prefixed a list of specimens which will be required to enable the student to follow for himself the writer's analysis; the descriptions are given in an extremely easy and lucid style, a few of the commonest scientific terms—but as few as possible—being gradually substituted for the colloquial English phrases at first employed. A sufficient acquaintance having then been obtained with the morphology of the more conspicuous organs, and their functions at the same time explained, the phenomena of nutrition, respiration, and fertilisation, and the structure of tissues, are described in chapters "On Fertilisation," "On Seeds," "On Early Growth and Food of Plants," "On Wood, Stems, and Roots," and "On Leaves." A chapter is then given to classification, to which is appended some useful tables of the characters of the more important orders; and this is followed by two or three chapters devoted to a few of the more important natural orders, and intended to serve as an introduction to the mode of naming plants. The most commonly used technical terms which have not been employed in the work itself are explained in an appendix, in which the wants of students preparing for the University Local Examinations have been kept in view.

The mistaken plan on which many botanical text-books have been compiled is so largely answerable for the horror in which the subject is held by candidates for examination who endeavour to cram facts and technical terms in an incredibly short space of time, without an attempt at practical work, and in the end fail miserably, that we cordially welcome an attempt to place the study on its true footing. We entirely concur in the view of the writer, that to this false method is due the fact that "Botany is so often stigmatised as a dry, uninteresting study;" an opinion which would speedily disappear were her mode of instruction in general use in the family and the school. Mrs. Kitchener's "A Year's Botany" seems to us admirably adapted for the purpose which she had in view in publishing it, and we heartily desire for it a large circulation.

A. W. B.

*Dental Pathology and Surgery.* By S. J. A. Salter, F.R.S. (London: Longmans, Green, and Co., 1874.)

THERE is much in dental surgery besides the simple extraction of teeth, and it is to the consideration of the science of dental pathology that Mr. Salter devotes most of the work under notice. The introductory chapters treat shortly of structure and function, development being left out of consideration. An excellent diagram explains the relation of the tongue to the different parts of the mouth during the pronunciation of the various letters of the alphabet, which latter is arranged on a physiological basis, dependent on the situation of the point of closure by which the sound is produced, upon the completeness or incompleteness of the closure, and upon whether the breathing is soft or aspirate. To the purely physiological student the chapter on irregularities in the position and union of contiguous teeth will be of particular interest; as will the instances given of defects in their number depending on hereditary causes, and on alopecia; to which we may add the peculiar deficiency always connected with the excessive development of hair over the face, as in the Russian man and child who so recently visited this country. The differentiation off from pure surgery of a class of tumours which, before Mr. Salter's investigations, were considered to belong to the bones themselves, and which, as odontomes, are now known to be composed of secondary dentine, will be specially instructive to the pathologist, as will the question of reflex nervous phenomena, such as partial paralysis and blindness, from the irritation of a diseased tooth. A full and very instructive account is also given of "phosphorus

disease," which attacks in so painful a manner the manufacturers of lucifer matches, and which can be so completely obviated by the employment in their construction of red instead of ordinary phosphorus, because the former does not give rise to the formation of acid fumes when exposed to the air, and therefore does not attack the mouth and teeth. There is one subject on which we have looked, but in vain, through this volume for information: it is for the explanation of how it is that tooth-disease and civilisation so unfortunately go hand in hand. The work will be found of special interest to all students of surgery.

### LETTERS TO THE EDITOR

[The Editor does not hold himself responsible for opinions expressed by his correspondents. Neither can he undertake to return, or to correspond with the writers of, rejected manuscripts. No notice is taken of anonymous communications.]

#### Deep-sea Researches

WHEN Prof. Wyville Thomson published his recent volume giving the results of the deep-sea researches conducted by himself and his colleagues, Dr. Carpenter, Mr. Jeffreys, and others, he also gave a sketch of the history of the subject; but he made no mention of my memoir on the Microscopic Organisms of the Levant Mud, published in 1847 in the Transactions of the Literary and Philosophical Society of Manchester, though this memoir had been referred to from time to time by Dr. Carpenter, Messrs. Parker and Rupert Jones, and others, and was, next to Ehrenberg's discovery of the microscopic structure of chalk, the starting-point of all these deep-sea investigations. It was the first to call attention to the existence of foraminiferous deposits in the sea, and to insist upon the organic origin of all limestones except a few freshwater Travertins, in opposition to the theory of chemical deposits that had previously been advocated in the works of Phillips and other geologists. I do not care very much about these questions of priority of observation, but since Dr. Wyville Thomson's article in NATURE, vol. xi. p. 116, dwells largely upon another point, which was also brought prominently forward in my memoir, I think it worth while preventing a repetition of the oversight, because the two subjects referred to, viz. the foraminiferous origin of calcareous deposits, and the subsequent modification of such deposits by the agency of carbonic acid gas, now prove, as I long ago insisted that they would do, two of the most important factors in the solution of the problem of the nature and origin of deep-sea deposits. Dr. Wyville Thomson, in the article in question, points out that extensive areas of the deep-sea bottom are now occupied by a reddish earth, and he has arrived at the conclusion that this earth is a residue left after all the calcareous Globigerine and other such elements have been removed by the solvent action of carbonic acid accumulated in these deep waters. In my memoir I arrived at the same conclusion from the study of the marine Tertiary deposits, containing Diatomaceæ, of Bermuda, Virginia, and elsewhere. I may perhaps be permitted to republish the following extracts from that memoir, since it is not now readily accessible to all the numerous naturalists who are interested in this question:—

"In the recent deposit of the Levant we have generally an admixture of calcareous and siliceous organisms. In some localities the latter are more sparingly distributed than in others; in a few instances they are almost entirely absent. The same admixture occurs in the recent sands from the West Indies. The soft calcareous mud from the bottom of the lagoons of the Coral Islands contains a considerable number of similar siliceous forms, and corresponding results have been obtained in most of the marine sediments from various parts of the globe, examined by M. Ehrenberg.

"On the other hand, the infusorial deposits of Bermuda and Virginia are altogether siliceous. Not one calcareous organism exists. The siliceous forms comprehend the majority of those which I have described from the Levant, many of them being not only similar but specifically identical, and the manner in which they are grouped together in these distant localities indicates something more than mere accident. Indeed, we want nothing but the calcareous structures to render these Miocene strata perfectly analogous to those now in process of formation both in the Mediterranean and in the West Indian seas. Are

these siliceous deposits, so void of any calcareous organisms, still in the condition in which they were originally accumulated? or were they once of a mixed character, like those of the Levant, having been subsequently submitted to some chemical action which has removed all the calcareous forms, leaving only the siliceous structures to constitute the permanent stratum? I am disposed to adopt the latter opinion, for several reasons."

After showing the resemblance between the residue left after treating certain substances with nitric acid, and the diatomaceous deposits, I proceed to say:—

"Such deposits, in these present conditions, stand out as anomalies in the existing order of oceanic phenomena, and have nothing resembling them except the local freshwater accumulations which occur in various places. Between these, however, no real analogy exists. It must not be forgotten that the Virginian deposit can be traced for above two hundred miles; and, being marine, would doubtless be mixed up with such marine products as were likely to occur along so extended a line. The only recorded instance with which I am acquainted, that exhibits the slightest resemblance, is furnished by M. Ehrenberg, in his examination of materials brought home from the south pole by Dr. Hooker. Some pancake ice, obtained in lat. 78° 10', long. 162° W., when melted, furnished seventy-nine species of organisms, of which only four were calcareous Polythalamia, the remainder being all siliceous. But even this example, remarkable as it is, does not supply us with any real parallelism. The deposits in question have never yet exhibited a single example of a calcareous organism."

After referring to the European greensands, I continue:—

"Nature furnishes us with an agent quite equal to the production of such effects as we are at present acquainted with. This is carbonic acid gas in solution in water. Mr. Lyell has already availed himself of the instrument to account for the subtraction of calcareous matter from imbedded shells, as well as for some of the changes that have taken place in the structure and composition of stratified rocks. . . . It is easy to conceive that whilst these strata were in a less consolidated state than at present, they might be charged with water containing carbonic acid gas. This would act as a solvent of the organic atom of lime until the acid was neutralised."

After venturing upon these conclusions in 1847, not as mere speculative guesses, but as the deliberate result of a long series of investigations carefully worked out, I need scarcely say how intense was the interest with which I read Dr. Wyville Thomson's observations, which so thoroughly sustain and confirm the accuracy of mine. My conclusions were wholly derived from the microscopic observations of earths and rock specimens which I compared with the few examples of foraminiferous ooze with which I was then familiar. The Challenger researches now show us how extensively the conditions described in my memoir have prevailed; a fact which could not have been ascertained before the machinery for deep-sea exploration attained to its present perfection. But having arrived at them in a decided or definite manner when the materials for doing so were much more scanty than they now are, and when no one except myself and the late Prof. Bailey of West Point were giving much attention to the subject, I think I am justified in wishing the fact to be placed on record.

Owens College, Dec. 12 W. C. WILLIAMSON

#### Origin of Bright Colouring in Animals

THE origin of the bright colouring of flowers, through natural selection effected by insects, appears to me one of the strongest points of the Darwinian theory. But I think the origin of the bright colouring of many animals, especially birds and insects, is on the contrary one of the greatest of its difficulties. Darwin accounts for it in most cases by sexual selection—the most beautiful males being the best able to obtain mates and to leave offspring.

In the way of this theory there are three very serious difficulties, which I think have not been dwelt on as they deserve.

1. Before special coloration could arise as a specific character, the colours must have been variable; for selection can work only when it has variation to work with, and it appears incredible that such a cause as sexual selection could ever give them that great degree of fixity. But the bars and spots on the wings of birds and butterflies are, as a rule, perfectly definite, and not more variable within the limits of the same species than any other part of the organism. This difficulty does not apply in the same degree to the origin of the coloration of flowers through

natural selection by 'insects, because the spots and streaks of flowers are much less sharply defined.

2. Why is ornamental colouring, as a rule, confined to the male? If the love of beauty is an animal instinct, why, on Darwinian principles, is not beauty developed in the females, the most beautiful females being the most likely to obtain mates and leave offspring? I speak chiefly of birds.

3. Is there any reason to believe that the female has any choice or power of selection whatever? I think that what evidence we have goes to prove that she is passive: and certainly this opinion is supported by the very general fact of the males fighting for the possession of the females.

If the love of beauty is an animal instinct, then Darwinian principles would require that the struggles of the males for the possession of the most beautiful females should develop beauty in the females by natural selection. But we see that the contrary is what takes place—beauty is developed in the male, the fighting sex.

Were a Darwin among birds to watch the ways of the human race, he would probably feel certain that the love of dress and ornament among women is altogether due to a desire to become attractive to men; and he would think those naturalists unsatisfactory, and perhaps mystical, who guessed the truth, that the love of ornament is a natural and healthy human instinct, not confined to either sex or to any age, but stronger in youth than in age, and stronger in woman than in man.

JOSEPH JOHN MURPHY

Old Forge, Dunmurry, Co. Antrim

#### Psychology of Cruelty

THERE is a passage in Mill's recently published essay on "Nature" which well merits the attention of evolutionary psychologists. It is as follows:—"Again, there are persons who are cruel by character, or, as the phrase is, naturally cruel; who have a real pleasure in inflicting, or seeing the infliction of pain. This kind of cruelty is not mere hardheartedness, or absence of pity or remorse; it is a positive thing; a particular kind of voluptuous excitement. The East, and Southern Europe, have afforded, and probably still afford, abundant examples of this propensity." (Page 57.)

Now, I think that this "hateful propensity" is of more common occurrence than even Mr. Mill here gives it credit for. Indeed, I doubt whether anyone is entirely devoid of it, although, of course, everyone who is sufficiently advanced in moral culture to admit of the subordination of the baser instincts to the higher, has been more or less successful in "starving it by disuse." I believe, in short, that this propensity must be regarded as one of the primary instincts of our nature, although, like other instincts, it varies in its original intensity in different individuals, and is further differentially modified by the various influences of education. The nature of this instinct is well expressed by Mr. Mill in the above-quoted phrase, "a particular kind of voluptuous excitement." This, I think, supplies the reason why it is, as a rule, of stronger development in men than in women, and why, as Mill observes, it is of most frequent manifestation in warm climates. It is also worth observing, that although thus akin to the amatory passion, it is of much earlier growth in the life-history of the individual. Indeed, childhood and youth are, in civilised society at least, the seasons when its presence is most conspicuous; in consequence, I suppose, of the restraining power which reflection subsequently brings to bear upon it not as yet having been called into action.

To explain the origin of this instinct by the evolutionary psychology is, I believe, impossible in the present state of our knowledge; for there is no period in the history of the race at which it is conceivable that the latter should have derived any benefit from the birth and development of this peculiar passion. Yet I believe it is now in some persons, were it permitted to assert itself, of even more intensity than is the highly beneficial inclination to which, as we have just seen, it is so strangely allied. To refer to the striking similarity of this passion in man to that which is manifested by monkeys, is not of course to explain its origin; but I am quite sure it is in the monkeys that this explanation is to be sought. Everyone knows that these animals show the keenest delight in torturing others simply for torturing sake, but everyone does not know how much trouble an average monkey will put himself to in order that he may gratify this taste. One example will suffice. A naturalist who had lived a long time in India told me that he has not unfrequently seen monkeys

feigning death for an hour or two at a time, for the express purpose of inducing crows, and other carnivorous birds, to approach within grasping distance; and when one of the latter were caught, the delighted monkey put it to all kinds of agonies, of which plucking alive seemed to be the favourite.

As I am not aware that any other animal exhibits this instinct of inflicting pain for its own sake—the case of the cat with a mouse belonging, I think, to another category—I believe, if its origin is ever to receive a scientific explanation, this will be found in something connected with monkey-life.

PHYSICUS

#### Migration of Birds

YESTERDAY and to-day (17th and 18th inst.) continuous flights of migrant birds, chiefly fieldfares and redwings, have passed over this place in one uniform direction, from east to west, turning inland to the north-west, as though unwilling to cross Poole Harbour. The procession, so far as it attracted my own notice, began with daybreak of the 17th, and was so rapid and continuous all that day that enormous numbers altogether must have passed over us. Close flocks would come, and then a continuous flight of stragglers, but all in one and the same direction, and with little deviation from a well-defined aerial pathway, as though keeping some visible high-road. Yesterday the flight was down the wind; this morning against it; and although the flight was low and the birds seemed tired, none alighted in this neighbourhood. Whence did they come, and whither are they bound—east or west of this place? Can any of your readers say? I. C.

Bournemouth, Dec. 18

#### The Potato Disease

IN his letter of last week, Prof. Dyer states that his main object in his previous letter was "to claim for a distinguished English botanist credit for work done by him thirty years ago." In his previous letter this work is defined by Prof. Dyer to be the discovery by the Rev. M. J. Berkeley of the fact that the potato disease was due to the attacks of a parasitic fungus. As the service, with which botanists are familiar, that Mr. Berkeley has rendered in this matter, is the publication and advocacy in this country of the discovery previously made by Montague and others, with a few additional observations of his own, Prof. Dyer would confer a favour on his fellow-botanists by giving a more exact reference to the records which he is so anxious should be duly recognised. INQUIRER

#### HELMHOLTZ ON THE USE AND ABUSE OF THE DEDUCTIVE METHOD IN PHYSICAL SCIENCE\*

SINCE the translation of the first part of this volume was published, its whole scientific tendency, and specially a series of individual passages in it, have been subjected to a more than vigorous criticism by Mr. J. C. F. Zöllner in his book "On the Nature of Comets." I do not think it necessary to answer expressions of feeling in reference to personal characteristics of the English authors or of myself. I have as a rule considered it necessary to reply to criticisms of scientific propositions and principles only when new facts were to be brought forward or misunderstandings to be cleared up, in the expectation that, when all data have been given, those familiar with the science will ultimately see how to form a judgment even without the discursive pleadings and sophistical arts of the contending parties. If the present treatise were intended only for fully educated men of science, Zöllner's attack might have been left unanswered. It is, however, essentially designed for students also, and as junior readers might perhaps be misled by the extreme assurance and the tone of moral indignation in which our critic thinks himself justified in expressing his opinions, I consider that it would be useful to answer the attacks made on the two English authors, so far as may

\* Translated by Prof. Crum Brown from Helmholtz's preface to the second part of the German edition of Thomson and Tait's "Natural Philosophy," vol. i.



be necessary to enable the reader to make out the truth by considering the matter for himself.

Among the scientific investigators who have especially directed their efforts towards the purification of physical science from all metaphysical infection and from all arbitrary hypotheses, and, on the contrary, have striven to make it more and more a simple and faithful expression of the laws of the facts, Sir W. Thomson occupies one of the first places, and he has consciously made precisely this his aim from the beginning of his scientific career. This very thing seems to me to be one of the chief services rendered by the present book, while in Mr. Zöllner's eyes it forms its fundamental defect. The latter would like to see, instead of the "inductive" method of the scientific investigator, a predominantly "deductive" method introduced. We have all hitherto employed the inductive process to discover new laws, or, as the case may be, hypotheses; the deductive to develop their consequences for the purpose of their verification. I do not find in Mr. Zöllner's book a distinct declaration by which his new mode of procedure may be distinguished from that generally followed. Judging from what he aims at as his ultimate object, it comes to the same thing as Schopenhauer's *Metaphysics*. The stars are to love and hate one another, feel pleasure and displeasure, and to try to move in a way corresponding to these feelings. Indeed, in blurred imitation of the principle of Least Action (pp. 326, 327), Schopenhauer's *Pessimism*, which declares this world to be indeed the best of possible worlds, but worse than none at all, is formulated as an ostensibly generally applicable principle of the smallest amount of discomfort, and this is proclaimed as the highest law of the world, living as well as lifeless.

Now, that a man who mentally treads such paths should recognise in the method of Thomson and Tait's book the exact opposite of the right way, or of that which he himself considers such, is natural; that he should seek the ground of the contradiction, not where it is really to be found, but in all conceivable personal weaknesses of his opponents, is quite in keeping with the intolerant manner in which the adherents of metaphysical articles of faith are wont to treat their opponents, in order to conceal from themselves and from the world the weakness of their own position. Mr. Zöllner is convinced "that the majority of the present representatives of the exact sciences are wanting in a clearly conceived intelligence of the first principles of the theory of perception" (p. viii.) This he tries to confirm by reference to supposed gross errors made by several of them.

Here then, of course, Messrs. Thomson and Tait must submit to the ordeal. They have, in paragraphs 381-385 of the present book given expression to their conviction as to the right use of scientific hypotheses. They, in paragraph 385, find fault with hypotheses which are too remote from observable facts, and select, as instances of their injurious influence, naturally only such as, by their extensive diffusion and by the authority of their originators, have been really influential. In this connection they place side by side the law of electrical action at a distance propounded by our countryman, W. Weber, and the emission theory of light as worked out by Newton. This juxtaposition is the best proof that the English authors had nothing in view that should wound a healthy German national feeling.

It has not as yet, I believe, come to such a pass in Germany—it is to be hoped it never will—that hypotheses may not be criticised, whatever be the eminence of their propounders. Should it actually ever come to this, then indeed Mr. Zöllner and his metaphysical friends would be justified in bewailing, or it may be in triumphing over, the destruction of German science. No one can be blamed for having advanced a hypothesis which the further progress of science shows to be inadmissible, just as it is no discredit for one who has to seek his way in

an entirely unknown country to take the wrong road for once, in spite of his utmost attention and consideration. It is further obvious that whoever regards as erroneous a hypothesis which has captivated the minds of a large number of scientific men must necessarily hold that it, for the time being, injures and retards the progress of science, and will be justified in expressing this opinion, if it becomes his duty to advise, according to his matured conviction, a student as to the path he should follow.

One of the arguments which Sir W. Thomson has adduced to prove the inadmissibility of Weber's hypothesis, is that it contradicts the law of the conservation of energy. I was also obliged to bring forward the same allegation somewhat later in a paper\* published in the year 1870. Now Mr. Zöllner, relying on the authority of Mr. C. Neumann, has assumed that this allegation is erroneous. On the contrary, Weber's law seems to him to be another universal law of all forces in nature (it is not explained how these different universal laws agree with one another), and he devotes twenty pages of his introduction to the purpose of airing his indignation at the intellectual and moral dullness of those who attack it. Mr. Zöllner will, no doubt, since then, have become aware that it is at least imprudent, without other support than the authority of one of the parties in a scientific debate, to try to help the other by libellous remarks, apart from the consideration that by such means one can contribute nothing to the settlement of the dispute, but perhaps much to its embitterment. Mr. C. Neumann was himself a party in this affair; my objections applied also to the theory of electrodynamic actions, to which he then adhered. He has since then given up this theory. He and also Mr. W. Weber thought that they could maintain the original theory of the latter, if they took into consideration the co-operative action of molecular forces in the case of closely approximated electrical masses. I then, in my second contribution to the theory of electro-dynamics,† pointed out that the assumption of molecular forces does not stop the leak in Weber's theory. In the meantime Mr. C. Neumann himself, before he knew of my second paper, had given up the attempt to found a theory of electro-dynamics upon Weber's law, and had tried to devise a new law for that purpose.

And here, in reference to the emphatic way in which our opponent speaks of the deductive method, I would make the following remarks on this example:—According to the view hitherto held by the best scientific investigators, the deductive method was not only justified, but indeed *required*, when the admissibility of a hypothesis was to be tested. Every legitimate hypothesis is an attempt to establish a new and more general law which shall include under it more facts than those hitherto observed. The testing of it consists in this, that we seek to develop *all* the consequences which flow from it, in particular those which can be compared with observable facts. I should therefore imagine the first duty of those who would support Weber's hypothesis to be, among other things, to see whether this hypothesis can explain the most general fact, that electricity, when no electromotive forces act on it, remains at rest in all electrical conductors, and is therefore capable of continuing in stable equilibrium. If Weber's hypothesis implies the contrary of this, as I have attempted to prove, then the next thing to be done would be to look out for such a modification of it as would render stable equilibrium possible in the largest as well as in the smallest conductors. According to my view, this would have been a right course, and the one required by the deductive method, but not to call a halt when inconvenient consequences appear, and excuse oneself with the plea that the right differential equations for the motion of

\* "Ueber die Bewegungsgleichungen der Elektrizität für rubende leitende Körper." Borchardt, *Journal für Mathematik*, Bd. 72, 75.  
† Borchardt, *Journal für Mathematik*, Bd. 75.



electricity in accordance with Weber's law had not yet been discovered. And if some one else takes this trouble, then he who considers himself a representative *κατ' ἐξοχήν* of the deductive method should applaud him, instead of charging him with impiety, even if the results of the inquiry should turn out to be inconvenient for the Icarus flight of speculation.

As Mr. Zöllner does not put himself forward as a mathematician—on the contrary, informs us on pages 426 and 427 of his book that the too frequent use of mathematics cramps the conscious activity of the understanding and is a convenient means of satisfying vanity; and besides, in many passages, constantly repeats his expression of contempt for those who think they can refute his speculations by pointing out mistakes in differentiation and integration—we ought not to judge him too severely in the matter of Weber's law. No doubt it is scarcely reasonable for one who thinks himself entitled to be shaky in his mathematics, to take upon himself to pronounce upon matters which can be decided by mathematical investigation only. His "Theory of Comets," which may surely be regarded as in his opinion a model specimen of how the right methods are to be employed, gives, besides this, other much more popular examples of the same peculiar way of using or not using deduction, examples the consideration of which may be reserved for another more suitable opportunity.

(To be continued.)

#### MOVEMENTS OF THE HERRING

THE mysterious disappearance of the body of herring which used to frequent Loch Fyne has directed renewed attention to the natural history of that fish. This is now the second time that the shoal of herrings which made Loch Fyne its *habitat* has deserted that celebrated sheet of water. No scientific opinion has yet been given as to the cause of this disappearance. A number of fishermen, resident on the Loch, say the herrings have been frightened away in consequence of persons fishing for them with a trawl net—which is, of course, nonsense; but not more nonsensical than the reasons assigned for the desertion by herring of other localities. As the so-called trawl-fishing of Loch Fyne (the net used is in reality a seine) was not in existence when the fish forsook the Loch on a former occasion, and were absent for a period of six years, the opinion of these men may be passed over as unworthy of serious consideration. Writers in the local newspapers, while inclined to favour the opinions of the drift-net men, that is, those who assert that the trawl-fishers have scared away the fish, also ask whether the spawning-beds may not have been in some way interfered with, and whether the body of fish frequenting the Loch may not from some unknown cause have departed before depositing their seed. If so, in what year would that occur? In other words, how long is it before the herring spawn of any given year comes to life, and at what period will the fish then born become reproductive?

These are events in the natural history of the herring, the dates of which have not yet been authoritatively settled. They are points, indeed, which have not yet been decided as regards any of our fish, except, perhaps, the salmon (*Salmo salar*), which has been nursed into life under a system that may be called artificial, that admitted of the young fish being watched, and their growth traced stage by stage, by means of certain signs and marks. It is thought that we may speak of the natural history of the salmon with more confidence than that of any of our other food-fishes. It is unfortunate that their studies of the natural history of the herring have not yet enabled naturalists to determine with exactitude how long it takes that fish to come to maturity.

Most varied opinions have been given on these points of herring life. Some persons have even gone the length of asserting that *Clupea harengus* and its congener *Clupea pilchardus* are able to perpetuate their kind within a year of their birth; even at the age of ten months! It has also been asserted that a herring is able to breed twice a year. Other opinions have been given, which assign to the herring a much longer period of growth, namely, that it requires from three to five years to reach maturity. Yarrell, again, and also Mitchell, think that it becomes reproductive in so short a period as eighteen months. What we may hold that we really do know is, that the eggs of the herring can be hatched within twenty days after their contact with the milt of the male fish. This has been proved by visiting the spawning places of the animals. On one visit all was spawn, everything that came in contact with the spawning-beds being covered with the seed of the herring; at the next visit, a fortnight after, the spawn was all gone; it had become vivified—and in proof of the fact, young herrings could in two or three weeks after be found in shallow places varying from an inch to two and even three inches in length. The probable time between the spawning of the fish and the fry reaching the dimensions named would be about forty days. How fast the young ones grow after that has not been authoritatively ascertained. It is thought, however, that if young herring reach the size of, say two-and-a-half inches, in forty days, it is not unreasonable to expect them to continue growing at the same rate.

In the case of *Salmo salar*, the period necessary for the incubation of the egg has been determined beyond dispute. It ranges from 90 to 130 days. The growth of the young fish, after a time, if those who have watched it have not been deceived, is very rapid. At first, however, the salmon grows very slowly. A salmon hatched in March last may still be a very tiny animal, even after it is twelve months and in some cases two years old. In a year, however, it may be four or five inches long, and ready to migrate to the sea. There is a curious feature in the natural history of the salmon, the law of which has never yet been discovered—it is a riddle, in fact, even to the most scientific observers: only one half of the salmon of any particular hatching develop into what is called the *smolt*, or migratory stage, at the end of about twelve or fifteen months from the time of their being hatched. The other moiety of the brood does not seek the sea or take on the migratory dress till the expiry of a little over two years from the time of birth! One half of the fish, therefore, will at one and the same time be tiny creatures, about three inches long, whilst the other moiety will be five inches in length, and of corresponding girth; but these dimensions, it must be confessed, show no great rapidity of growth. Indeed, it is not till after the salmon proceeds to the sea that its growth becomes at all rapid; but, notwithstanding this rapidity, it must, we think, be a considerable number of years before a salmon can attain to the weight of fifty or sixty pounds; although the smolt, it is affirmed by those who have watched it, returns as a grise to its native waters in about three months, its size and weight being very largely increased.

The herring, as we all know, is a fish that never attains to any great size, and the weight of which may be counted in ounces. The question to be answered is this: Do small fish grow to maturity quicker than large ones? It has been asserted, in some quarters, that the herring grows quite as rapidly as the smolt does after it reaches the salt water, and the rate of growth there appears magical, when contrasted with its slow progress during the first year of its existence, or it may be, as has been already explained, the first two years. We are not, however, without a certain kind of proof of the rate at which the herring grows, which is better than reasoning analogically. It is quite fair to conclude that if herrings attain a size of about three inches within forty days or so of their birth,

they will attain their full dimensions within a year. It is known of herring, by means of personal observation, that from the time the roe or milt begins to develop itself, that is, when they become *maties*, no very long time elapses till they are ready to spawn: ten weeks has been estimated as about the time the herring takes to grow from a "matie," or fat fish, to a spawning herring.

The most contradictory accounts of the time at which herrings spawn have been published by various inquirers. Much of this confusion results, no doubt, from the fact that the herring is somewhere engaged in fulfilling this function of its life during nearly every month of the year. There are, it is thought, distinct races of this fish constantly coming to maturity and spawning at suitable times with the instinct of keeping up the breed. Thus, at Wick, on the Caithness coast, where there is still a great fishery carried on, although it is evidently now on the wane, herrings came to maturity and were ready to spawn in July. At one time large numbers of these (July) herrings were caught; indeed, some economists say too many were caught, and that in consequence the reproductive strength of the shoal was so impaired, or its economy so deranged, that it became exhausted. At any rate, few herrings are now taken in July at Wick. The great August shoal is being also over-fished, and symptoms are not wanting in the violent fluctuations which occur in the "takes," that it too will in time become unproductive. Herrings are found in the Firth of Forth ready to shed their spawn in the months of December, January, and February, and during these months young herrings and sprats (*Clupea sprattus*), are found mixed in the shoals which are fished at that period of the year. The question of where these schools of young fish go to whilst they are growing naturally presents itself. But who can answer it? The theory of the migration of the herring from and to the seas within the arctic circle has been long exploded, it having been established, it was thought, beyond cavil, that it is a native of our own seas: at all events, that it comes close to certain parts of the British sea-coasts to deposit its spawn. It is at that period of its life that we become familiar with the herring, and that is the time at which it can be most economically captured. Herrings are seen at that period of their lives in prodigious numbers; in fact, they lie in tiers on a favourite spawning ground, covering several square miles of sea-bottom. If all the parks of London were united together into one great space of ground, it would not nearly represent the width and length of a shoal of herrings engaged in spawning!

It has been asserted that herrings aggregate and segregate, but proof of this fact in their natural history is lacking. Almost immediately after the spawn has ripened into life, the tiny herrings are seen crowding together on the most shallow places of the coast, where they are safe from the attacks of larger fish, which would assuredly prey upon them if they frequented the deeper water. Now, if these fish separate, when do they do so? because, if they come to maturity, as is said, within a year, they have little time to live apart. If they go out to sea, how far do they go? It is a fact that at the time they are caught they are at first taken at a considerable distance from land. The writer has been out as far as twenty-five miles from the shore without finding a trace of the shoal; but within ten days or so the fish were found within a radius of ten miles of the port from which he had sailed in search of them, and they gradually came nearer and nearer, being often caught within two miles of the land. Although the fish of particular localities have such distinctive marks upon them as to render it easy to distinguish them, certain persons have again mooted the idea of the herring being a migratory animal, and that a great fish-shoal travels from the north to the south. A writer in a recent number of the *Scotsman* newspaper speaks of a vast shoal of herrings having arrived at

Wick, then of its passing Fraserburgh and Peterhead; next, of its being found at Dunbar and Eyemouth; then on the coast of Northumberland; and finally, he tells us, it will be found at Yarmouth, on the coast of Norfolk! What else is this but a revival of a portion of the old myth? The shoal must be constantly finding out new places to visit, and must also be deserting places where it used to call; it must also tell off brigades to spawn at different localities; otherwise, all that we have learned about the natural history of the herring during the last few years is imaginary. Any novice, almost, could distinguish a herring taken from Loch Fyne, when placed side by side with a herring caught off the bay of Wick. Fraserburgh, one of the places cited by the writer in the *Scotsman*, has only risen to importance as a herring port within the last ten years; close upon seven hundred boats were this year engaged in the fishery, whilst in 1864 there was not much above a fourth of that number. At Fraserburgh, and two or three little fishing stations which adjoin it, 181,000 crans of herrings were captured this year, and these fish would be of the value of about 300,000*l.* The capture by the boats fishing from Peterhead—also on the Aberdeenshire coast—this season would not be of less value than a quarter of a million pounds sterling. But whilst these Aberdeenshire ports are rising into notice as great centres of the herring fishery, other ports are declining. Wick, which used to be the capital of herring fishery enterprise, is now on the decline as a curing station. Why? For the simple reason, it may be presumed, that the owners of boats do not find it profitable to fish at that port. At one time as many as 1,200 boats used to fish for the Wick curers, but the number at work this year was five hundred less! Such a falling off is very striking, and goes a long way to prove that it is possible to "over-fish" the herring, or at least so to derange the economy of the shoals as to render them in time unproductive. It is only reasonable to argue that with the largely augmented drifts of nets increased quantities of herring ought to be captured, but it is being annually demonstrated that such is not the case, and that to keep up present supplies and provide for the supply demanded by an exigent and increasing population, more boats and still more extensive drifts of nets are required.

Even very young fishermen have seen the rise and decline of important seats of the herring fishery, apparently from the over-fishing or derangement of the shoals. It will be instructive to note what occurs in future to the Wick fishery, because, only a few years ago, it was the greatest herring-curing station in the world, whilst next year there is every probability of its being only a fourth-rate fishing port. The fishermen will naturally go where they can take their prey with the least possible trouble, and where the fishery is more regular than it has been during late years at Wick, where most of the fish have been taken by a few of the more fortunate fishermen, and many of the boats had to return morning after morning "clean." The boats fishing at Fraserburgh this year took each an average of 220 crans of herrings, and all of them were tolerably well fished; whilst the Wick boats only averaged ninety-four crans, the fishing being even more partial than usual. The further development of the fishery at Fraserburgh, Aberdeen, and Peterhead, which extends over a space of about forty miles, will be anxiously watched. The shoal or shoals which are yielding such wealth to the fishermen of these ports must be prodigious in size and wonderfully productive; let us take note how long they last, and keep a correct tale of what they yield. The run upon them for the next two or three years will only be limited by the accommodation which the harbours can give to the boats and the ground which can be allotted to the curers. The movements of the herring become yearly more interesting, and we cannot be too well informed in regard to them.

## THE TRANSIT OF VENUS

THE following telegrams have been received by the *Times* since our last issue.

"Melbourne, Dec. 11.—The American Expedition in Tasmania experienced unfavourable weather for their observations of the Transit of Venus."

"Sydney, Dec. 10.—The Transit observations here proved satisfactory."

"Berlin, Dec. 17.—A telegram has been received from the German Astronomical Expedition at Tschifu, in North-eastern China, announcing that the observation of the Transit of Venus was quite successful. The observation of the contact, the heliometer measurement, and the photographs succeeded splendidly. The expedition was admirably supported by His Imperial Majesty's ship *Arcona*."

From Major Palmer, Christchurch, New Zealand:—  
"English, nothing valuable anywhere—clouds. Americans got ingress, and photographs till near third contact. Nobody egress."

From Mr. Todd, Adelaide:—  
"Transit of Venus.—Ingress cloudy. Egress well observed. Contacts 34434, 3475. (Probably 3h. 4m. 43.4s., and 3m. 7.5s. Adelaide mean time, for internal and external contacts.) No black drop."

From Vienna:—  
"According to a telegram received by the Imperial Academy of Sciences from Drs. Weiss and Oppolzer, who went to observe the Transit of Venus at Jassy, the observation of external contact at the moment of the exit has succeeded. As they had time to fix the exact longitude and latitude of their point of observation, they obtained reliable data for calculation. The longitude was determined by telegraphic time signals with the Observatory in Vienna. As Jassy lies on the limits of the line where the phenomenon was visible, they attribute some importance to their observations."

Through Reuter's agency:—  
"Pekin, Dec. 9.—The French astronomical party, under the direction of M. Fleuriat, succeeded in observing the first and second contacts. There was a slight black ligament. Photographs were taken. The weather was slightly hazy."

It will be seen that the news from New Zealand is of a most serious character, so far as the English scheme of observation is concerned. In fact, unless the French, Germans, and Americans have secured observations, the Delisle attack, so far as egress is concerned, has failed altogether. We shall postpone any further remarks till next week, as in the interval some information may be received from the stations to which we have referred.

## NOTES

We are informed that the Council of the Royal Society has appointed a Committee to consider the means of securing observations of the total eclipse of the sun in April next, to which they attach great importance.

PROF. CLERK-MAXWELL, F.R.S., has promised to give a lecture at the Chemical Society on Feb. 18 next, "On the Dynamical Evidence of the Molecular Constitution of Bodies."

The *Times* states that Prof. Huxley is to undertake the duties of the Chair of Natural History in the University of Edinburgh during the ensuing summer session, in the absence of Prof. Wyville Thomson, who is with the *Challenger* Surveying Expedition.

The Arctic Expedition Committee sits twice a week, and is making steady progress in organising preparations. The engines of the *Cygnat* gunboat, a new vessel, are to be removed and placed in the *Alert*, now in dock. Although not yet officially

announced, we believe that the Admiralty have selected Commander Albert Markham as one of the commanding officers of the Arctic Expedition. Lieut. Aldrich, of the *Challenger*, is coming home with Capt. Nares to take part in the expedition. The decision recently made public that none but those of the Royal Navy would be permitted to take part in the expedition has been somewhat relaxed, and it is not improbable that some men of experience in whaling will be engaged as "ice quartermasters."

We believe a few French naval officers desire to join the forthcoming English Polar Expedition, as Lieut. Bellot did on the occasion of one of the most interesting searches for Franklin. As is known, Bellot lost his life during the expedition, and the fact is commemorated by a column erected at Greenwich Hospital at the expense of the English Government.

LIEUT. CAMERON, in a despatch to Lord Derby, dated Ujiji, May 14, tells of an important discovery to which we briefly alluded last week in our report of the meeting of the Geographical Society: "He has been all round the southern portion of Tanganyika, and believes he has discovered its outlet in a river named the Lukuga, a little to the south of Speke's Islands. He thinks also, from what he has heard from the Arabs, that the Lualaba is the Congo. The Lukuga he found to be obstructed with grass, but he believes a way might easily be cut through that. If Lieut. Cameron's conjectures turn out to be correct, and there appears to be great likelihood that they will, he will deserve to take an important place in the ranks of African explorers. He shows the great capabilities of Central Africa as a field for legitimate commerce, and if it turns out that navigation is possible from the mouth of the Congo to the Tanganyika region, much good may be expected to accrue to Africa as well as to the commercial world at large. The curse of the country is still those degraded Arab slave-dealers who vexed the soul of poor Livingstone, and it is a monstrous pity that some steps could not be taken to stamp out the demoralising and devastating traffic. Full details of Lieut. Cameron's explorations are in the hands of the Geographical Society."

THE last two parts of Petermann's *Mittheilungen* are naturally full of the Payer-Weyprecht expedition. The December number contains two letters from Lieut. Weyprecht, and one from Lieut. Payer, to Dr. Petermann. The former intimates that the amount of material collected in connection with the geography, meteorology, magnetism, &c., is immense; during the course of next year he will be preparing these for publication. He briefly states, as some of the conclusions he draws from the work of the expedition, that it is erroneous to conclude either that an open polar sea exists in the north, or that the ice on the south of Franz-Joseph's Land is impenetrable; that the drift of the ship in the ice was in no way owing to the Gulf Stream; and that he still adheres to the opinion that much valuable exploratory work can be done towards the east, with the Siberian coast as a basis of operations. Lieut. Payer believes that the nearest road to the pole is that by which the English Arctic Expedition is to go—Smith's Sound.

THE *Daily Telegraph* of Monday contains a long letter giving a very interesting account of Zanzibar, from Mr. H. M. Stanley, the leader of the expedition sent out by that paper in conjunction with the *New York Herald*. Another is to follow giving a description of the preparations for Stanley's long African march of discovery, and the detailed plans of route. This expedition is exceedingly creditable to the two papers, and it is a hopeful sign that a daily journal finds it answer to fill its columns with such healthy excitement.

A COMMUNICATION from her Majesty's ship *Scout* states that a monument has been erected on one of the islands of the Pacific to the memory of Captain Cook, who was killed by the natives of Owhyhee, ninety-five years ago. The monument is an

obelisk 25 ft. high, and mounted on a base 8 ft. square. It is of concrete, and bears the following inscription:—"In memory of the great circumnavigator, Captain James Cook, R.N., who discovered these islands on the 15th of January, A.D. 1778, and fell near this spot on the 14th of February, A.D. 1779. This monument was erected in November, A.D. 1874, by some of his fellow-countrymen." It is erected on a suitable spot, about 100 yards from the rock on which the captain fell.

M. LEVERRIER, having finished with his tables of the Planet Neptune, will resume the duties of an active observer. For 1875 he will superintend personally the service of meridian observations at the Observatory of Paris, at the same time fulfilling all the duties of director of the establishment. M. Loewy will have the care of the special determinations of longitudes. These arrangements have been proposed by the Council of the Observatory to the Ministry, and will be no doubt approved of.

THE process of polishing the lens of the mirror of the great telescope is going on at the French National Observatory by M. Martin. The diameter of the lens is 120 centimetres, and the polisher is a disc of 40 centimetres. The number of men engaged on the polishing is six. They are obliged to stop frequently on account of the great weight of the polisher. An observer placed on the top of the Observatory, at a distance equal to half the focal distance, superintends the polishing process, watching if the image of a light which is placed in a proper position is reflected with sufficient exactness by the mirror below.

THE weather being very cold in Paris, and heavy falls of snow having taken place, M. Gaston Tissandier has taken advantage of the opportunity to make a series of most interesting observations on the dust which snow appropriates during its passage through the atmosphere. The results will be sent very shortly to the French Institute.

ON Thursday, December 17, at ten P.M., a magnificent falling star was observed in Paris. Its track was to be seen for more than a minute. A correspondent, Mr. J. H. A. Jenner, writing from Lewes, states that "on Thursday evening, the 17th inst., at 10.30, a very fine meteor was seen here. It travelled from north to south at a seemingly very low elevation, and though the moon was shining brightly, it was a very brilliant object, being several times the brightness of Sirius. Its colour was yellowish, and it left a long but not very persistent bluish-white train. Had the night been dark, it must have been a very splendid object. The point of disappearance was hidden from my sight by houses, but there was no noise attending it."

TWO students of Girton College have been examined in the Cambridge Natural Science Tripos. Miss Kingsland, daughter of the Rev. N. Kingsland, Congregationalist minister, Bradford, passed equal to second class, and has been appointed assistant lecturer in Natural Science and Mathematics at Girton College. The other, Miss Dove, daughter of the Rev. J. Dove, vicar of Cowbit, Lincolnshire, would have been entitled to the ordinary degree, and has been appointed to an assistant mistress-ship at Cheltenham Ladies' College, with a special view to teaching physiology. These ladies passed the *viva voce* examination, and also in physiology and chemistry.

DR. J. G. M'KENDRICK recently commenced in Edinburgh a series of lectures to ladies on Physiology, at which we are pleased to hear there is an attendance already of seventy-one ladies.

THE Laurium mines in Greece have given rise to a new difficulty, not of a diplomatic, but of a botanical nature. Seeds which had been buried amidst the remains of old explorations for 2,000 years, on being exposed to the air have undergone the usual

process of germination, &c. These belong to the genus *glaucaum*, but the species seems quite lost.

THE *Telegraphic Journal* for December 15 contains a figure and description of a most ingenious self-regulating electric lamp, by Siemens and Halske. This lamp is of very simple construction, and is stated to regulate itself with great accuracy. It is capable of being used either with a current of single direction or with the alternating current produced by certain magneto-electric machines.

WE have before us a Belgian Governmental publication in the *Bulletin de la Fédération des Sociétés d'Horticulture de Belgique*, for 1873. The volume contains biographies and portraits of eminent Belgian horticulturists recently deceased. A number of papers are printed in it, chiefly connected with Belgian horticulture; and it is supplemented by a list of all persons holding official botanical posts throughout the world.

LIEUT. CONDER, R.E., the officer in charge of the Palestine Survey Expedition, reports important discoveries of ruins in the hill country of Judah, which he proposes to identify with some of the lost Biblical cities and sites. He has been also engaged in a search for the limits of the Levitical towns, hoping to find some inscription or monument similar to that which rewarded M. Ganneau at the city of Gezer. He has not found any Hebrew inscriptions, but appears to have discovered boundary stones which may prove to be the ancient Levitical landmarks. Lieut. Conder promises to make a survey of Mr. Henry Maudsley's recent discoveries on Mount Zion for the Committee of the Palestine Exploration Fund.

THE report is to hand of Prof. Powell on the Survey of the Colorado of the West, dated Smithsonian Institution, Washington, D.C., April 30, 1874. This survey was placed under the direction of the Smithsonian Institution by Congress. The region embraced in the survey is one of the most interesting, in a geological point of view, in the world. The Colorado of the West and its tributaries traverse a series of remarkable chasms, in some instances of more than a mile in depth below the general surface of the region, presenting in several places, at one view, sections of the greater number of the known geological formations of America. In the report a general summary is given of the entire work. It exhibits a great amount of labour, and a series of results, not only of importance to science, but also to a knowledge of the country in its relations to agriculture and mineralogy. The report embraces a statement of what has been accomplished in the way of, first, Topography, as based on triangulation, including a description of the arable valleys, the supply of water, the extent of timber and of pasture land; second, Geology, including economic mineralogical products, such as coal, salt, and other minerals; third, Ethnology, comprising tribes, political organisation, languages, manners, customs, mythology, poetry, arts, &c.; fourth, Natural History, including mammals, birds, reptiles, insects, and plants.

SOME time since we intimated in NATURE that the enterprising Tyneside Naturalists' Field Club had resolved to catalogue all the remarkable trees in the extensive district which it works. The paragraph referred to has, we are glad to see, been the means of originating a similar enterprise in America. The New England Society of Orange, New Jersey, has issued the first of a series of publications, under the name of the "Babbit Portfolio," giving a history and description of the notable trees in its locality, accompanied by beautifully executed photo-engravings. The first number contains the "Valley Oak" (*Quercus albus*), the "Hillyer Elm" (*Ulmus americana*), and the "Harrison Buttonwood" (*Platanus occidentalis*). Dr. Babbit, after whom the Portfolio is named, was the first to set out shade-trees in Orange.

PROF. BUCKLEY, State Geologist of Texas, has published a synopsis of the work done under his auspices during the past season, and remarks that fifty-four counties have been visited by himself and assistants. The results of his investigations show that Texas has vast deposits of iron and coal, of much greater extent than had been anticipated. Both are of excellent quality, and in some cases they occur near together. He has also found an abundance of salt, gypsum, and a wide range of copper ores. Other valuable minerals are roofing slate, marble, soapstone, &c.

THE Engineer Department of the United States Army has issued a "Catalogue of Plants collected in the years 1871, 1872, and 1873, with Descriptions of New Species." This is a portion of a series of publications brought out under the same auspices, being a report of geographical and geological explorations and surveys west of the 100th meridian, under the charge of First-lieutenant G. M. Wheeler.

WE are pleased to learn from the "Tenth Report of the Board for the Protection of the Aborigines in the Colony of Victoria," that the condition of the aborigines from the foundation of the colony was never so prosperous as at the present time. Very successful experiments at hop-growing have been made in some of the districts allotted to the natives, who take kindly to the light and comparatively well-paid work. The cultivation of hops will be extended to other districts. Considerable success has also been attained in the education of the children.

DR. JOHN DOWSON has sent us two pamphlets of which he is the author: "Thoughts, Philosophical and Medical, selected from the Works of Francis Bacon," and "A Sketch of the Life and Works of Erasmus Darwin, M.D., F.R.S." H. K. Lewis, Gower Street, is the publisher.

THE *Quarterly Journal* of the Meteorological Society, just issued, contains a number of papers read during the last session of the Society, abstracts of most of which have appeared in these pages.

THE "Proceedings of the Belfast Natural History and Philosophical Society" for 1872-3-4 have been published. Among the papers of scientific interest are the President's (Mr. J. J. Murphy's) addresses, "On Cosmological Science," and "On the present state of the Darwinian Controversy;" Prof. Everett "On Mirage," published in NATURE, vol. xi. p. 49; "On some New Methods of Chemical Analysis," by Prof. Hodges; "On the Solar Spots," by Mr. Murphy; "On Rainbow, Halos, and Coronae," by Prof. Purser; "On Underground Temperature," by Prof. Everett; "On the Origin and Metamorphoses of Insects," by Mr. Murphy; "On the Composition of an Inflammable Gas issuing from below the Silt-bed in Belfast," by Dr. Andrews, F.R.S.

WE have received two reprints from the "Proceedings" of the Liverpool Geological Society, 1873-74: "The Metamorphic Rocks of the Malvern Range and the Strata derived from them," by Dr. C. Ricketts, F.G.S.; and "Tidal Action as a Geological Cause," by Mr. T. Mellard Reade, C.E., F.G.S.

It is gratifying to see, from the Seventh Annual Report of the Eastbourne Natural History Society, that the Society is, on the whole, in a flourishing condition. It is doing very satisfactory work in the collection and arrangement of the fauna and flora of its district.

THE additions to the Zoological Society's Gardens during the past week include a Peregrine Falcon (*Falco peregrinus*), European, presented by Mr. A. F. Ross; a Campbell's Monkey (*Cercopithecus campbellii*) from West Africa, purchased; and eight Canadian Beavers (*Castor canadensis*) from North America, deposited.

### THE ROYAL SOCIETY MEDALS

WE have already announced the names of those to whom the Royal Society Medals have been awarded; the following is the official account of the presentation by the Vice-President and Treasurer, Mr. Spottiswoode, at the Anniversary Meeting on the 30th ult.:-

The Copley Medal has been awarded to Prof. Louis Pasteur, one of our foreign members, "for his researches on Fermentation and on Pebrine."

Prof. Pasteur's researches on fermentation consist essentially of two parts: the first part, in which he enters exhaustively into the examination of the products formed in this process; and the second, in which he takes up the question of the cause of fermentation.

Previous observers had noticed the production, in solutions of sugar which had been fermented, of substances other than the two commonly recognised, alcohol and carbonic acid; but it remained for Pasteur to show which were essential and which were occasional products. In the series of able papers contributed to the *Comptes Rendus* and to the *Annales de Chimie et de Physique*, he proved conclusively that succinic acid and glycerine were always found in fermented solutions of sugar, while lactic acid and acetic acid, although occasionally present, were not always so. He also showed that, in addition to these substances, a part of the sugar was converted into cellulose and fat.

The study of the products formed during fermentation opened the way to the second part of the research, viz., the cause of fermentation.

It had been found that certain solutions, when exposed to the air, soon became full of living organisms; and Pasteur's experiments led him to support the view that these organisms originated from the presence of germs floating in the air. He found that no living organisms were developed if care were taken to destroy completely all those which might be present in the solution, and if the solutions were then carefully sealed up free from air. Nor was it necessary to exclude the air, provided that pure air, free from germs, were admitted. By passing the air through red-hot tubes or through gun-cotton before reaching the solutions, he found that the development of organisms, in such boiled solutions, did not take place. An exception to this was noticed in the case of milk, which required to be heated to a higher temperature than the boiling-point of water at atmospheric pressure. Pasteur showed that this was connected with the alkaline reaction of milk, for in all cases in which the development of life was prevented by heating to the boiling-point of water, the solutions had a faintly acid reaction—but that when this was neutralised by carbonate of lime, the solutions then behaved like milk.

Prof. Pasteur also examined the gun-cotton through which the air had been passed; and he found, among other things, certain cells to which he attributed the power of causing the growth of organisms in solutions. By sowing some of these cells in solutions which previously had remained clear, and finding that such solutions speedily became turbid from the growth of living organisms, it was proved that the air which had passed through the gun-cotton had lost its property of causing the development of life in solutions, because the germs which the air contained had been stopped by the gun-cotton.

The result of the second part of the research may be thus summed up:-

1. No organisms are developed in solutions if care be taken to prevent the possibility of the presence of germs.
2. This negative result does not depend upon the exclusion of oxygen.
3. The matter separated from ordinary air is competent to develop organisms in solutions which previously had remained unchanged.

Not less important were the results of Pasteur's experiments respecting the chemical functions of the ferment.

It had been held that the entire ferment was in a state of putrefactive decomposition, and induced a similar decomposition in the sugar with which it was in contact.

In corroboration of this view, it was stated that ammonia (a product of the decomposition of albuminous substances such as those present in the ferment) is always found in liquids which are undergoing fermentation.

Pasteur proved that the ammonia in fermenting liquids diminishes in quantity in proportion as the process advances, and that the yeast-cells increase and grow while forming complex albuminous substances at the expense of the ammonia and other

aliments which are supplied to it. He found that, in addition to ammonia and sugar, the cells require mineral substances, such as phosphates and other constituents, which are present in the organism of every healthy and growing yeast-cell.

In short, he proved that those conditions which are most favourable to the healthy growth and development of the yeast-cells are most conducive to the progress of fermentation, and that fermentation is impeded or arrested by those influences which check the growth or destroy the vitality of the cell.

The above results are but samples of the fruits of Pasteur's long series of researches in this subject. Many and many an able investigator had worked in the same field; and such were the difficulties they encountered, that Dumas himself recommended Pasteur not to waste his time in working at so hopeless a subject.

To the biologist, two of Pasteur's researches are of very great interest and importance. He has shown that *fungi* find all the materials needed for their nutrition and growth in water containing an ammonia salt and certain mineral constituents, and devoid of any nitrogenised organic matter; and he has proved that all the phenomena presented by the destructive silkworm epidemic, the *pebrine* (even the singular fact that it is hereditarily transmitted through the female, and not through the male), are to be explained by the presence of a parasitic organism in the diseased caterpillars.

The medal was received for Prof. Pasteur by the Foreign Secretary of the Society.

The Rumford Medal has been awarded to Mr. J. Norman Lockyer, F.R.S., "for his Spectroscopic Researches on the Sun and on the Chemical Elements."

Mr. Lockyer has long been engaged in spectroscopic researches on the sun. His first observations were directed to a scrutiny of the spectrum of sun-spots as compared with that of the general surface, with a view to bring evidence to decide between two rival theories respecting their formation. In the course of the paper in which his first observations were described, and which was read before the Royal Society on November 15th, 1866, he asks, "May not the spectroscope afford us evidence of the existence of the 'red flames' which total eclipses have revealed to us in the sun's atmosphere, although they escape all other modes of examination at other times?"

The spectroscope he then employed proved to be of insufficient dispersive power for his researches, and he was induced to apply to the Government-Grant Committee of the Royal Society for aid to construct one of greater power. This aid was accorded, and the instrument was delivered, though not quite complete, on the 16th of October, 1868. On the 20th his efforts were crowned by the detection of a solar prominence by means of the bright lines exhibited in his spectrum. An account of this discovery was immediately communicated to the Royal Society and to the French Academy of Sciences.

Meanwhile had occurred the total solar eclipse of August 18th, 1868, to observe which various parties had gone out armed with suitable instruments, and especially with spectroscopes, for determining the character of the hitherto unknown spectrum of the prominences; and the first-fruits of their labours had reached Europe, showing that the spectrum in question is one of bright lines. It occurred to M. Janssen, who had observed with eminent success the spectrum of the prominences during the eclipse, that the same mode of observation might enable one to detect them at any time, and he saw them in this manner the very next day. The first account of this discovery, which was sent by post, did not, however, reach the French Academy until a few days after the communication of Mr. Lockyer's notice; so that nothing interferes with the perfect independence with which these two physicists established the possibility of detecting the prominences at any time.

A discovery like this opened up a new field of research, which Mr. Lockyer was not backward in exploring. One of the first-fruits of the application of the method was the discovery of a continuous luminous gaseous envelope to the sun, which he calls the chromosphere, of which the prominences are merely local aggregations. Evidence was further obtained of gigantic convulsions at the surface of the sun, which were revealed by slight alterations of refrangibility in the lines, observed in a manner similar to that in which Mr. Huggins had determined the relative velocity of approach or recess of the Earth and Sirius.

The interpretation of spectroscopic solar phenomena required a re-examination in several respects of the spectroscopic features of artificial sources of light. Among these researches special mention must be made of Mr. Lockyer's classification of the lines

due to the metals of the electrodes between which an induction discharge was passed, according to their "length," *i.e.*, the distance from the electrodes to which they could respectively be traced. This led to the explanation of various apparent anomalies as to the presence or absence of certain dark lines in the solar spectrum, and to the detection of additional elements in the sun, especially potassium, an element which, though so common on the earth and so easily detected by spectral analysis, had not previously been proved to exist in the sun, because the attention of observers had been turned in a wrong direction, as was shown by these researches.

Nor was it only in relation to solar physics that these researches bore fruit. They led to a *quantitative* determination in many cases, by means of the spectroscope, of the proportion of the constituents in an alloy, and afforded new evidence of the extent to which impurities are present even in substances deemed chemically pure.

The medal was received by Mr. Lockyer.

A Royal Medal has been awarded to Mr. Henry Clifton Sorby, F.R.S., "for his researches on slaty cleavage and on the minute structure of minerals and rocks; for the construction of the Micro-Spectroscope, and for his researches on colouring-matters."

The principal grounds on which Mr. Sorby's claims to a Royal Medal rest are the following:—

1. His long-continued study, and his successful application of the microscope to the solution of problems in petrology.

2. His employment of the prism in conjunction with the microscope for the analysis of the colours transmitted by substances, as well organic as inorganic.

Though Mr. Sorby's labours during the last ten years have been more particularly devoted to observations of the latter class, his work, extending over a period that commenced in 1849, is represented in the Catalogue of Scientific Papers (limited by the year 1863) by no less than forty-seven memoirs. Among the more remarkable of these must be mentioned the reports to the British Association and the contributions to the *Philosophical Magazine* (1853, 1856, 1857), in which he grappled with the subject of slaty cleavage, and helped to establish the explanation that cleavage was the result of greater relative condensation of the material in a direction perpendicular to the cleavage, due in the case of rocks to mechanical compression in that direction—an idea that met with immediate illustration from other experimentalists.

His memoirs on the temperatures and pressures at which certain rocks and minerals were formed (in the *Geological Society's Journal*, 1858), founded on the relative volume of the liquid and vacuous portions of microscopic hollows, or, again, on the character of microscopic substances mingled with the mineral matter he investigated, convinced the geologist that he had to take into account the action of water under high pressures and at high temperatures in explaining the formation of granitoid rocks. And the refinement of the methods that Mr. Sorby employed for making his rock-sections at Sheffield has made those methods the models sought after by the now large school of Continental and English microscopic petrologists.

His applications of spectroscopic methods to the microscope fall more strictly within the limit of ten years, as they have been worked out since 1867, when Mr. Sorby first described his adaptation of the spectroscope to the microscope, as carried out by Mr. Browning.

The observations he has made with this instrument, and generally by combining optical examination with the use of chemical reagents, have extended over a very wide range—such as the recognition of blood-stains, of adulteration in wine, the means of discriminating among the compounds of certain of the metals, chiefly of zirconium, titanium, and uranium, by the aid of blow-pipe beads—and finally to the elucidation, to a considerable extent, of the causes of the complexity in the tints exhibited by plants in the different stages of development of their annual foliage and flowers.

These are only some of the more important of Mr. Sorby's contributions to science; and they are characterised by an untiring application of the methods of experimental research to a great variety of subjects suggested by a very ingenious and active mind.

The medal was received by Mr. Sorby.

A Royal Medal has been awarded to Prof. William Crawford Williamson, F.R.S., "for his contributions to Zoology and Paleontology, and especially for his investigation into the structure of the fossil plants of the coal-measures."

Prof. Williamson's contributions to biological science were commenced forty years ago, and embrace investigations into the structure of the Foraminifera, the Rotifera, the scales and bones of fishes, and the fossil plants of the Carboniferous and Oolitic periods. These comprise works of great merit and value, not only on account of their accuracy and the extent and novelty of the observations which they contain, but by reason of the breadth of view and the philosophical spirit which pervade them.

His labours in Vegetable Palaeontology are above all remarkable, being alike laborious, searching, and productive of important results. These are embodied in six contributions (of which the last will soon appear) to the Philosophical Transactions upon the organisation of the fossil plants of the coal-measures—and one on the restoration of a Cycadeous tree (*Zamia gigas*) from the Yorkshire Oolite, published in the Transactions of the Linnean Society. These are not only models of laborious research and exact description, but they are illustrated by more than fifty plates, devoted to microscopic analyses of vegetable tissues, obtained by making transparent slices of the fossils. Both the slices and the drawings are made by Prof. Williamson himself, who thus, to his reputation as a biologist, unites those of an accomplished artist and a skillful lapidary, qualifications which should be named along with those for which the medal is awarded, because no unscientific lapidary could have obtained equally illustrative sections, and no common artist could have depicted them with equal exactitude. The more important results thus obtained refer to the structure, affinities, and reproductive organs of *Calamites* and its allies, to *Lepidodendron*, *Sigillaria*, *Lepidostrobus*, *Asterophyllites*, and to other genera of the Carboniferous epoch.

In addition to these contributions to the history of previously known genera of that epoch, Prof. Williamson has been able to show, on the one hand, that groups of now living plants which were not previously supposed to have a great geological antiquity, actually flourished during the Carboniferous period, and, on the other, that plants of that period which had been previously referred with confidence to groups now living, have in reality other and widely different affinities.

The medal was received by Prof. Williamson.

### SCIENTIFIC SERIALS

*Astronomische Nachrichten*, No. 2014.—In this number appear some interesting observations made by Nicolaus V. Konkoly on the spectrum of meteorites. Some 130 of the August meteorites were examined, and it was observed that the nucleus gave a continuous spectrum, the apparent colour of the naked eye predominating in the spectrum. The tail of the yellow meteorites gave the sodium lines only, the green one gave magnesium lines, and the red ones strontium or lithium. The sodium lines were present in all. In some of the larger meteorites the author suspects the spectrum of iron is present.—Position observations of Coggia's comet are given by Argelander and by Tebbutt, of the Windsor Observatory, N.S. Wales.—Dr. Klein writes objecting to the explanation of variation of brightness of Jupiter's moons during transit, given by Herr S. Alexander.—Dr. Luther gives position observations of Peitho (118) and elements of Danie (61).—The elements of Borrelly's comet are given by Grützmacher, and those of Sylvia by Tietjen.—F. Anderson sends an opposition ephemeris of the planet *Urdina* for November and December.—Prof. Spörer gives observations of sun-spots and protuberances; and observations of the occultation of Venus by the moon, taken at Kiel, are given.

*Zeitschrift der Oesterreichischen Gesellschaft für Meteorologie*.—Dec. 1.—In an article on the non-periodic movements of the barometer and the baric windrose, Dr. Köppen, taking into consideration the almost constant cyclonic movement of the air in Europe, asks how it is, while gradients are steepest with west and south-west winds, that when the barometer is observed at equal distances round a minimum centre, it is not found to be highest where the south-west wind is blowing. The mean height of the barometer is on the contrary considerably higher with north and east winds. The explanation lies in the difference between northern and southern Europe with respect to the magnitude of non-periodic oscillations of the barometer.—The low pressure in the north and north-west during the prevalence of south-west winds is not compensated by an adequately high pressure in the south and south-east. Air flows

thence either to form a maximum over a small space in high latitudes, or southwards over a large space without causing high pressures. Similarly, but conversely, with north and east winds.—Among the "Kleiner Mittheilungen" we have a notice of Prof. Dove's article on cool Mays after mid January, published in the magazine of the Berlin Academy. Herr Dove regards as proved a tendency to low temperatures in spring after warm winters. It appears that a mild January is generally followed in the interior of continents by a mild May, on the north and east coasts by a cool May, on the Atlantic Ocean again by a May milder than usual.

### SOCIETIES AND ACADEMIES

#### LONDON

Royal Society, Dec. 10.—"On the Development of the Teeth of the Newt, the Frog, and certain Lizards, and on the Structure and Development of the Teeth of Ophidia." By Charles J. Tomes, M.A.

The descriptions given by Arnold and Goodsir of the development of the human teeth have been already demonstrated to be in material respects inaccurate as applied to man and other Mammalia; and the present paper shows that the accounts propounded by Prof. Owen, of the process in Batrachia and Reptilia, which are practically an extension of the theories of Goodsir in these classes, are even more at variance with the facts of the case.

There is in no Batrachian or Reptile any open groove or fissure ("primitive dental groove"); there are, at no period of development, free papillae; consequently the whole process of "encapsulation" has not any existence, but is purely hypothetical. From first to last the whole process of tooth-development takes place in solid tissue, beneath an even and unbroken surface; with which, however, the young tooth sacs have a connection through a band of epithelial cells. The first process is a dipping down of a narrow process of the oral epithelium, the extremity of which, after it has penetrated in some, as the snake, to a great depth, becomes dilated, and is transformed into the enamel organ; and this is the case whether a recognisable coat of enamel is or is not to be found on the perfect tooth. Subsequently to the dipping in of the band of epithelium, and concomitantly with the dilatation of its end, a dentine pulp is formed opposite to it. This may constitute the entire tooth sac, which is then wholly cellular, as in the newt; or it may go on further to the formation of a connective-tissue tooth capsule. The external thin structureless coating of the teeth of Ophidia is derived from an unmistakable enamel organ, developed as above described; it is therefore enamel, and not cementum, as it is denominated by Prof. Owen. The successional tooth sacs, very numerous in the snakes, are located in a sort of capsule: this character, peculiar to the Ophidia, and most marked in the lower jaw, is of obvious service during the extreme dilatation which the mouth undergoes, as is also the tortuosity of the process of epithelium, before it reaches the collection of tooth sacs. The epithelial band may be traced winding by the side of the older tooth sacs till it reaches the position of the youngest, where it ends in a crecæ extremity, to be transformed into the enamel organ next developed. In fine, the stages of open groove, free papillae, and encapsulation of the same have no existence whatever in Batrachia and Reptilia, their existence having been previously disproved in Mammalia.

"Experiments showing the Paramagnetic condition of Arterial Blood, as compared with the Diamagnetic condition of Venous Blood." By Richard C. Shettle, M.D.

The experiments consist in suspending between the poles of a powerful electro-magnet arterial blood, hermetically sealed in a glass tube, in a medium of venous blood, and venous blood in the same tube, previously well emptied of its contents, in a medium of arterial blood, care being taken to avoid as far as possible any exposure of the blood to the atmosphere; thus preventing any alteration in its physical characteristics as regards the gases which it contains.

In the former of the two cases the testing tube was found to take an axial, and in the latter an equatorial position.

Dec. 17.—"Note on the Vertical Distribution of Temperature in the Ocean." By J. Y. Buchanan, chemist on board H.M.S. *Challenger*. Communicated by Prof. A. W. Williamson, For. Sec. R.S.

From newspapers and other reports which have been received



by late mails, it appears that the distribution of temperature in the ocean is occupying the attention of a certain portion of the scientific public, and even giving rise to considerable discussion. The observations made on board this ship, and more especially in the Atlantic, have furnished the greater part of the material on which the various speculations have been founded. It appears to me that one point suggested by these observations has not received sufficient attention from those who have written and spoken on the subject—I mean the effect of the changing seasons on sea-water. Consider the state of the water at and near the surface of the ocean, somewhere not in the tropics. To be more precise, let us suppose that we have taken up our position in the middle of the North Atlantic, somewhere about the 30th parallel. This part of the ocean is not vexed with currents, and affords the best possible field for the observation of the phenomenon in question. The whole ocean, enclosed by the 20th and 40th parallels of north latitude, and the meridians of 30° and 60° west longitude, forms one oceanic lake, not affected by the perturbing influence of currents or of land; and where, therefore, the true effect of differences of atmospheric temperature on the waters of the ocean may be most advantageously studied. Let us assume the winter temperature of the surface-water to be 60° F., and the summer temperature to be 70° F. If we start from midwinter, we find that, as summer approaches, the surface water must get gradually warmer, and that the temperature of the layers below the surface must decrease at a very rapid rate, until the stratum of winter temperature, or 60° F., is reached; in the language of the isothermal charts, the isothermal line for degrees between 70° F. (if we suppose that we have arrived at midsummer) and 60° F. open out or increase their distance from each other as the depth increases. Let us now consider the conditions after the summer heat has begun to waver. During the whole period of heating, the water, from its increasing temperature, has been always becoming lighter, so that heat communication by convection with the water below has been entirely suspended during the whole period. The heating of the surface water has, however, had another effect, besides increasing its volume; it has, by evaporation, rendered it denser than it was before, at the same temperature. Keeping in view this double effect of the summer heat upon the surface water, let us consider the effect of the winter cold upon it. The superficial water having assumed the atmospheric temperature of, say, 60° F., will sink through the warmer water below it, until it reaches the stratum of water having the same temperature as itself. Arrived here, however, although it has the same temperature as the surrounding water, the two are no longer in equilibrium, for the water which has come from the surface has a greater density than that below at the same temperature. It will therefore not be arrested at the stratum of the same temperature, as would have been the case with fresh water, but it will continue to sink, carrying of course its higher temperature with it, and distributing it among the lower layers of colder water. At the end of the winter, therefore, and just before the summer heating recommences, we shall have at the surface a more or less thick stratum of water, having a nearly uniform temperature of 60° F., and below this the temperature decreasing at a considerable, but less rapid rate, than at the termination of the summer heating. If we distinguish between *surface water*, the temperature of which rises with the atmospheric temperature, following thus, in direction at least, the variation of the seasons, and *sub-surface water*, or the stratum immediately below it, we have for the latter the (at first sight) paradoxical effect of summer cooling and winter heating. The effect of this agency is to diffuse the same heat to a greater depth in the ocean, the greater the yearly range of atmospheric temperature at the surface. This effect is well shown in the chart of isothermals, on a vertical section between Madeira and a position in lat. 3° 8' N., long. 14° 49' W. The isothermal line for 45° F. rises from a depth of 740 fathoms at Madeira, to 240 fathoms at the above-mentioned position.\* In equatorial regions there is hardly any variation in the surface-temperature of the sea; consequently, we find cold water very close to the surface all along the line. On referring to the temperature section between the position lat. 3° 8' N., long. 14° 49' W., and St. Paul's rocks, it will be seen that, with a surface-temperature of from 75° F. to 79° F., water at 55° F. is reached at distances of less than 100 fathoms from the surface. Midway between the Azores and Bermuda, with a surface-temperature of 70° F.,

it is only at a depth of 400 fathoms that we reach water of 55° F.

The above theory of vertical diffusion of temperature in the ocean, owing to convection brought about by the yearly range of temperature at the surface, presupposes that (at least in regions where the range is considerable, and where the great vertical diffusion of heat in question is observed) the slightly concentrated water, descending from the surface as the winter approaches, does not meet water of greater density at the same temperature than its own. Unfortunately the determination of the specific gravity of water below the surface is much less simple than that of the temperature. For although we have an instrument which gives, within any required degree of accuracy, the density of the water at any depth in exactly the same way as the thermometer gives its temperature, the results of the observations are composed of three factors, which depend on the temperature, the pressure, and the *salinity*. By sending down a thermometer along with it we might clear the result for temperature; by noting the depth we might clear for pressure; but the result so cleared would not represent the salinity of the water at the depth in question, but the average excess of salinity of the column of water above it, over or under the mean salinity assumed for sea-water, in the calculation of the pressure exercised by a column of it. There remains, therefore, nothing for it but to fetch a sample of water from each depth, and determine its specific gravity on board. As this is an operation which takes up some time, the number of "serial specific gravity" determinations is comparatively small.

The following are the results of two which were obtained on the voyage between Bermuda and the Azores. The results show the specific gravity at 60° F., that of water at 39° 2' F. being taken as unity.

I. was taken on June 18, 1873, in lat. 35° 7' N., long. 52° 32' W.

II. was taken on June 24, 1873, in lat. 38° 3' N., long. 39° 19' W.

For comparison I give one equatorial and one South Atlantic "serial specific gravity" determination.

III. was taken on Aug. 21, 1873, in lat. 3° 8' N., long. 14° 49' W.

IV. was taken on Oct. 3, 1873, in lat. 26° 15' S., long. 32° 56' W.

Depth in fathoms.	Specific gravity at 60° F. Distilled water at 39° 2' = 1.			
	I.	II.	III.	IV.
0	1'02712	1'02684	1'02591	1'02703
50	...	...	1'02658	1'02682
100	...	...	1'02643	1'02649
150	1'02701	1'02677	...	...
200	...	...	1'02620	1'02608
250	1'02683	1'02641	...	...
300	...	...	1'02610	1'02573
400	...	...	1'02629	1'02554
500	1'02604	1'02608	...	...

From the figures in the Table it will be seen that in that part of the ocean the specific gravity of the water in summer decreases from the surface downwards. As a rule it attains an inferior limit at a depth of from 400 to 500 fathoms, which it preserves to the bottom. In those latitudes, therefore, the stratum of intermixure extends down to 500 fathoms; and this may be said also to be the depth to which the sun's influence at the surface penetrates. The results in column III, show the curious phenomenon of the surface water being specifically lighter than any water below it, and that under an equatorial sun. The position of this sounding was peculiar, inasmuch as it was within line of separation between the Guinea and the equatorial currents. All along the equatorial section the water at 50 and 100 fathoms was found to be specifically heavier than either at the surface or that at greater depths. All along the equator, however, a current runs with great velocity; and I have invariably observed that strong surface-currents introduce considerable irregularities into the specific gravity of the water near the surface. The effect of the greater specific gravity at 100 fathoms conspires, of course, within the small yearly range of temperature, in pre-

\* There will, I think, be no violence in assuming an acquaintance with these charts, at least among the scientific public, as they have lately formed the subject of lectures by Dr. Carpenter, and will no doubt have been published before this reaches England.



venting vertical diffusion in the above described manner. Column IV, shows a return, in the southern hemisphere, to a state of things similar to that which obtains in the North Atlantic.

We have seen that the effect of climate in equatorial regions is to render the sub-surface water much colder than it is in temperate regions; let us consider what would be the effect of a polar climate on the sea-water. It must be observed that the effect of the atmospheric temperature on the sea is determined by the temperature assumed by the surface-water; now the lowest temperature which surface-water can attain is its freezing-point. As the temperature of the air when the *Challenger* was beyond the 60th parallel was almost constantly below  $32^{\circ}$  F., freezing must go on to a very great extent in winter, and the effect of freezing such water is, in the end, similar to that of evaporating it; it is separated into lighter ice, and denser mother-liquor, which sinks, leaving ice on the surface. This ice I found to be a mixture; and on determining the melting-point of some in crystals, which had formed in a bucketful of sea-water, I found it began to melt at  $29.5^{\circ}$  F., the water produced by it being almost fresh, in comparison with sea-water. The lowest temperature of surface-water registered was  $27^{\circ}$  F.; this happened on two occasions, but was quite exceptional, the usual surface-temperature varying from  $32^{\circ}$  to  $34^{\circ}$  F. At this temperature a sensible quantity of ice would melt, giving very light surface water. On two occasions the specific gravity of the surface water was found between 1.02400 and 1.02410. The specific gravity increased rapidly up to a depth of 100 fathoms, when it remained pretty uniform to the bottom. Here, as at the equator, it is in winter that the sub-surface water perceives the effect of the change of season, the mother-liquor of the forming ice diffusing in its descent the temperature of its formation.

In the discussion of oceanic phenomena too much attention is usually paid to the great currents. When it is wished to study the phenomena due to temperature, or to any single cause, the effect of the winds, which is seen in its most intense form in the ocean currents, should be eliminated as far as possible; which in this case can only be done by selecting comparatively motionless seas, like the one which I have mentioned in the North Atlantic.\* When the effect of atmospheric climate has been studied on the ocean at large, it would then be proper to apply the experience gained to the consideration of the more complicated phenomena of the currents.

I am at present engaged in a detailed consideration of the temperature and specific gravity results, principally in the direction above indicated, and hope shortly to be able to send it home for publication.

"On Polishing the Specula of Reflecting Telescopes," by W. Lassell, F.R.S., V.P.R.A.S.

The object of this paper is to describe a method of giving a high lustre and true parabolic curve with ease and certainty, by appropriate machinery, to the surfaces of the specula of large reflecting telescopes.

Linnean Society, Dec. 17.—Dr. Allman, president, in the chair.—Dr. Allman read a paper on "The diagnosis of new genera and species of hydroids," which we will give next week.

—Mr. Daniel Hanbury exhibited specimens of an African *Kleinia* which had flowered at Mentone.—Mr. Pryor exhibited branches of the famous "Glastonbury Thorn," noted for always flowering in December.—Sir J. Lubbock, Bart., F.R.S., read "Observations on Bees, Wasps, and Ants." In this paper the author continued the observations read before the Linnean Society last year. In order to test the power of communication which they possessed, he placed various bees on honey, but found that if the honey was out of sight and in a place not frequented by bees, few, if any, others came. For instance, he brought a bee to a honeycomb, weighing 12½ lbs., placed on his writing table; she returned over and over again, but no other bee came. Other experiments of the same kind convinced him that some bees at any rate do not communicate with their sisters, even if they find an untenanted comb full of honey, which to them would be a perfect Eldorado. This is the more remarkable because these bees began to work in the morning before the rest, and continued to

\* It will be seen that the principle, that the depth to which the effect of the sun's rays penetrates depends on the yearly range of temperature of the water at the surface, explains the presence of the large body of comparatively warm water in the North Atlantic, the existence of which has been usually ascribed to an assumed reflux or back water of the Gulf Stream. The warm water is due to no extraneous cause, but is the natural effect of the conditions of climate at the surface; and the effect of these conditions of climate are so apparent in the temperature of the water, just because it is free from the influence of oceanic currents, and exposed to the effects of climate alone.

do so even in weather which drove all the rest into the shelter of the hive. That a few strange bees should have found the honey is natural enough, because there were a good many bees about in the room. With reference to the affection which bees are said to feel for one another, he observes, that though he had repeatedly seen them lick a bee which had smeared herself in honey, he never observed them show the slightest attention to any of their comrades who had been drowned in water. Far, indeed, from having been able to discover any evidence of affection among them, they appear to be thoroughly callous and utterly indifferent to one another. As already mentioned, it was necessary for him occasionally to kill a bee, but he never found that the others took the slightest notice. Thus, on the 11th of October he crushed a bee close to one which was feeding, in fact so close that their wings touched; yet the survivor took no notice whatever of the death of her sister, but went on feeding with every appearance of composure and enjoyment, just as if nothing had happened. When the pressure was removed, she remained by the side of the corpse without the slightest appearance of apprehension, sorrow, or recognition. It was, of course, impossible for her to understand his reason for killing her companion, yet neither did she feel the slightest emotion at her sister's death, nor did she show any alarm that the same fate should befall her also. In a second case exactly the same occurred. Again, if while a bee is feeding, a second bee is held by the leg close to her, the prisoner, of course, struggles to escape and buzzes as loudly as she can, yet the selfish (?) eater takes no notice whatever. So far, therefore, from being at all affectionate, he doubts whether bees are in the least fond of one another. Their devotion to their queen is generally quoted as a most characteristic trait; yet it is of the most limited character. For instance, on one occasion he changed his black queen for a Ligurian, and placed the old queen with some workers in a box containing some comb. Sir John was obliged to leave home on the following day, but when he returned on the 20th he found that all the bees had deserted the poor queen, who seemed weak, helpless, and miserable. On the 31st the bees were coming to some honey at one of his windows, and he placed this poor queen close to them. In alighting, several of them even touched her, yet not one of them took the slightest notice of her. The same queen, when afterwards placed in the hive, immediately attracted a number of bees. Although the experiments on colour which Sir John has already recorded are tolerably conclusive, still he thought it would be worth while to make some more. For instance, he brought a bee to some honey which he placed on blue paper, and about three feet off he placed a similar quantity of honey on orange paper. After the bee had returned twice he transposed the papers, but she returned to the honey on the blue paper. After she had made three more visits, always to the blue paper, he transposed them again, and she again followed the colour, though the honey was left in the same place. The following day he was not able to watch her, but on the 14th she returned to the honey on the blue paper. He then again transposed the papers. At 8.5 she returned to the old place and was just going to alight, but observing the change of colour, without a moment's hesitation dashed off to the blue. No one, he says, who saw her at that moment could have entertained the slightest doubt about her perceiving the difference between the two colours. He then proceeded to recount some experiments on the sense of smell possessed by bees, on their power of recognising their own companions, and on the different occupations of different bees, mentioning observations which seem to show that the bees act as nurses during the first few weeks of their life, and only subsequently take to collecting honey and pollen. He then proceeded to mention some experiments on wasps, which show that they possess the power of distinguishing colour. In conclusion he recorded a number of experiments on ants, which certainly seemed to show that, whatever may be the case with bees, ants do possess the power of communicating detailed facts to one another. It is remarkable, however, how much individual ants appear to differ from one another in character.

Chemical Society, Dec. 17.—Prof. Gladstone, F.R.S., vice-president, in the chair.—A paper on Groves' method of preparing chlorides, by Dr. Schorlemmer, F.R.S., was read. He finds that the process does not answer well for the higher primary alcohols, although secondary chlorides can readily be prepared by it. The other papers were: On the precipitation of metals by zinc, by Mr. G. L. Davies; Researches on the paraffins existing in Pennsylvanian petroleum, by M. T. M.

Morgan; Some remarks on the preceding paper by Dr. Schlorlemmer; and a Note on Aricine by Mr. D. Howard, who finds that this is really a distinct alkaloid existing in certain kinds of reputed cinchona barks.—The Chairman announced that Prof. C. Maxwell had promised to give a lecture on the 18th of February, On the dynamical evidence of the molecular constitution of bodies.

Meteorological Society, Dec. 16.—Dr. R. J. Muir, president, in the chair.—The following papers were read:—Atmospheric pressure and rainfall, by John C. Bloxam, F.M.S.—Remarks on West India Cyclones, by H. F. Jahneke. This paper is a continuation of a former one read before the Society in February last.—Notes on the weather experienced over the British Isles and the north-west of France during the first few days of October 1874, by R. H. Scott, F.R.S. The object of this paper was to show that the charts in the *Bulletin International* are drawn upon insufficient data. It also recommended the adoption of the conical projection on charts for meteorological purposes.—On a new self-registering hygrometer, by H. Negretti, F.M.S., and J. W. Zambra, F.M.S.—Results of meteorological observations made at and near St. Paul's Island, in the South Indian Ocean, by R. H. Scott, F.R.S.—Description of a new patent portable magnetic anemometer and current meter for maritime use, by R. M. Lowne.

Entomological Society, Dec. 7.—Sir Sidney Smith Saunders, C.M.G., president, in the chair.—Mr. E. A. Fitch exhibited some oak-galls formed by insects of the genera *Dryocosmus* and *Aphidiotrix*, of which descriptions had been published in a recent number of the *Entomologist's Monthly Magazine*, together with three curious bud-galls, unknown, from Rayleigh, in Essex.—Mr. Champion exhibited a box of Hemiptera, collected by Mr. J. J. Walker in different places near the Mediterranean.—Prof. Westwood forwarded a letter he had received from Mr. Stone, accompanying a sample of tea imported from Shanghai, infested by a small beetle which proved to be the *Pinus hololeucus*. Also a letter from Prof. Forel, of Lausanne, stating that the *Phylloxera vastatrix* had made its appearance among some vines at Pregny, in the canton of Geneva, which had been introduced from England into the graperies of the Baron Rothschild, and that the *Phylloxera* had been discovered in two of his greenhouses among vines planted in 1869, sufficiently distant from each other to render it improbable that the insect had been communicated one from the other; and he therefore concluded that the disease had been introduced in 1869 from the graperies in England. He was anxious to ascertain whether the vines in the English graperies were less influenced than those out of doors; but none of the members present were aware of the occurrence of the insect in England out of doors, as it had hitherto appeared in greenhouses only.—Mr. C. O. Waterhouse communicated some "Synonymical Notes on Longicorn Coleoptera."

## PARIS

Academy of Sciences, Dec. 14.—M. Frémy in the chair.—The proceedings commenced by M. De Lacaze-Duthiers presenting to the Academy the first two volumes of his "Archives of Experimental Zoology."—The following papers were then read:—On the originating centres of the plague of 1858 and 1874; epidemic nature and contagion of this plague; by M. J. D. Tholozan.—Note on the distribution of water in Egypt and in Greece, by M. Belgrand.—M. Le Verrier presented a new theory of the planet Neptune.—Determination of the velocity of light and of the sun's parallax, by M. A. Cornu. As the mean of 504 experiments, the author has obtained the value 300,000 kilometres per second for the velocity of light *in vacuo*. The determination of the solar parallax is determined in three ways: (1) Observation of the eclipses of Jupiter's satellites—mean result 8' 85. (2) Analytical methods founded on the comparison of astronomical observations with theoretical laws based on the principle of gravitation—mean result 8' 86. (3) Geometrical methods founded on the parallactic displacement of certain planets. Result obtained from opposition of Mars in 1862 was 8' 84.—Observations on the phenomena essential to fertilisation in the fresh-water Algae of the genus *Batrachospermum*, by M. Sirodot.—Theory of cyclonic meteorological phenomena, by M. Couste.—Observations on the reproduction of the *Phylloxera* of the vine, by M. Balbiani.—The American species of the genus *Phylloxera*, by Mr. C. V. Riley. The author

recognises sixteen well-defined species.—Method followed in searching for the most efficacious substance to oppose to *Phylloxera* at the viticultural station of Cognac, by M. Max Cornu.—Experiments made with poisonous agents on healthy vines, by M. Baudrimont.—Telegrams from M. Janssen, director of the Japanese Transit of Venus Expedition, to the Minister of Public Instruction, to the Academy of Sciences, and to the "Bureau des Longitudes," were read. Letters referring to the transit were received also from M. E. Mouchez, director of the station at St. Paul, and from M. Fleurbaey, director of the Pekin station.—Observations on Borrelly's last comet, by M. Stéphan.—On the stability of equilibrium of a heavy body resting on a curved support, by M. C. Jordan.—On cubic residues, a note on the theory of numbers, by M. P. Pepin.—On two simple laws of the active resistance of solids, by M. J. Boussinesq. This is a continuation of the former paper bearing this title.—Observations relating to a recent communication by M. Volpicelli on electric induction, by M. E. Blavier.—On the inconvenience of employing vessels of Bohemian glass in chemical analysis, and particularly in alkalimetry, by M. P. Truchot. The author states that French soda glass is not sensibly attacked by boiling water.—On the action of hydrogen on silver nitrate, by M. N. Békétoff. It had been stated by M. Roussel that silver nitrate was reduced by hydrogen, while, on the other hand, M. Pellet maintained that pure hydrogen had no action on solutions of this salt, and that reduction was effected in such cases by the presence of traces of arsenic in the hydrogen employed, or by the presence of an excess of silver oxide in the nitrate. The author of the present communication made, therefore, a series of experiments with carefully purified hydrogen, from which he concludes that this gas does reduce the nitrate either in neutral or feebly acid solutions. The recent researches by Dr. Russell in this country on the same subject do not seem to have come under the author's notice.—Action on the economy of the derivatives of the biliary acids, on the colouring matters of the bile, and on cholesteroline, by MM. V. Feltz and E. Ritter.—Anæsthesia produced by the intra-venous injection of chloral in a case of hollowing of the tibia and ovariotomy; acidity of the chloral solution; method of neutralising it, by M. Oré.

## BOOKS AND PAMPHLETS RECEIVED

BRITISH.—Gums, Resins, Oleo-Resins, and Resinous Products in the India Museum or printed in India: Dr. M. C. Cooke (London, India Museum).—Economic Geology; or, Geology in its relation to Arts and Manufactures: David Page, LL.D., F.C.S., &c. (Wm. Blackwood).—The Last Journals of David Livingstone, 2 vols.: Horace Waller, F.R.G.S. (John Murray).—Origin of Creation; or, the Science of Matter and Force: Thos. K. Fraser and Andrew Dewar (Longmans).—The Botanical Locality Record Club: Report of the Recorder for 1873 (E. Newman).—Anthropological Notes and Queries: British Association (Stanford).—The Conflict between Religion and Science: J. W. Draper, M.D. (H. S. King and Co.).—The Doctrine of Descent and Darwinism. International Series: Oscar Schmitz H. S. King and Co.)

AMERICAN.—The "Babbit Portfolio." New England Society of N.J., (United States).—Memor of the Founding and Progress of the United States Observatory: Prof. J. E. Nourse, U.S.N. (Washington).

FOREIGN.—Bulletin de la Fédération des Sociétés d'Horticulture de Belgique (Liège).

## CONTENTS

PA

PROTECTION FOR INVENTIONS. . . . .	141
LIVINGSTONE'S "LAST JOURNALS." (With Illustration). . . . .	142
INDIAN METEOROLOGY . . . . .	145
OUR BOOK SHELF . . . . .	147
LETTERS TO THE EDITOR:—	
Deep-sea Researches.—Prof. W. C. Williamson, F.R.S. . . . .	148
Origin of Bright Colouring in Animals.—JOSEPH JOHN MURPHY . . . . .	148
Psychology of Cruelty . . . . .	149
Migration of Birds . . . . .	149
The Potato Disease . . . . .	149
HELMHOLTZ ON THE USE AND ABUSE OF THE DEDUCTIVE METHOD	
IN PHYSICAL SCIENCE . . . . .	149
MOVEMENTS OF THE HERRING . . . . .	151
THE TRANSIT OF VENUS . . . . .	153
NOTES . . . . .	153
THE ROYAL SOCIETY MEDALS . . . . .	155
SCIENTIFIC SERIALS . . . . .	157
SOCIETIES AND ACADEMIES . . . . .	157
BOOKS AND PAMPHLETS RECEIVED . . . . .	160

THURSDAY, DECEMBER 31, 1874

## GALTON'S "ENGLISH MEN OF SCIENCE"

*English Men of Science; their Nature and Nurture.*  
By Francis Galton, F.R.S., author of "Hereditary  
Genius," &c. (London: Macmillan and Co., 1874.)

IT would be difficult to overrate the exact and scientific spirit in which Mr. Galton proceeds with his investigation into the origin of genius and the antecedents of successful promoters of science.

The work of M. de Candolle upon the history of two hundred scientific men who have lived during the two last centuries appears to have suggested the character of the present work in some degree. But Mr. Galton has attacked the problem in a novel manner, by going directly to men living in the present day, and presenting a series of questions as to their parents, characters, and education. He began by carefully selecting a list of scientific men, which, though not intended in any way to be exhaustive, should at least not include any but those who have shown true ability. For this purpose he adopted election to the Royal Society, since the method of election was reformed, as the first test; and out of the considerable number of such Fellows he next selected those who had earned a medal for scientific work, had presided over a learned society or section of the British Association, had been on the Council of the Royal Society, or, finally, had acted as professors in some important college or university.

The list thus framed was found to contain 180 names. Incidentally Mr. Galton inquires what fraction this number forms of the total number of scientific men living in the United Kingdom and possessing the same general scientific status. By various tests he arrives at the conclusion that the total number would be three hundred, and he estimates that their proportion to the male population of the same ages would be about that of one in ten thousand. Of course Mr. Galton must be aware that his definition of scientific men is purely arbitrary, and that the circumscribing line might have been drawn more or less strictly, and made to include almost any number.

For the purposes in view, however, Mr. Galton's procedure must be considered perfectly satisfactory. To every one of the 180 men he forwarded elaborate printed forms, covering seven large quarto pages, and containing an immense number of minute inquiries. Each man was requested to state his parentage and descent, the religious opinions, occupations, birthplace, political party, health, stature, complexion, temperament, size of head, and a great many other particular facts concerning both his parents and himself. Inquiries were also made regarding his brothers and sisters, and their salient characteristics. The numbers and principal achievements of more distant relatives, grandparents, uncles and aunts, cousins, nephews, and nieces were also to be stated. Finally, the mode and duration of education of the scientific man himself was to be described, and the causes of success of which he was conscious were to be analysed.

In order to estimate the degree of intensity of characteristics, Mr. Galton devised a very ingenious and highly scientific method of class notation, founded on the law

of error or divergence from a mean. This method was employed in his work on "Hereditary Genius," and was also described in his lecture before the Royal Institution in 1874. Instead of saying that a person's memory was remarkable, or prodigious, or moderate, or poor, the answerer was to attempt to define with some numerical precision the proportion which persons of each degree of memory bore to the whole population, by assigning him to one or other of certain defined classes. If such definite answers could have been obtained, the theory of probability could have been directly applied and the amount of the influence of heredity mathematically investigated. Such a method would constitute a distinct advance in statistical inquiry. Unfortunately, few definite answers of the kind seem to have been received, and this branch of the inquiry had for the present to be abandoned.

When we consider the elaborate and careful manner in which Mr. Galton conducted his investigation, it is difficult not to feel some slight disappointment at the results as stated in this volume. The book is certainly one of very great interest and not devoid of amusing points; but it seems to me to fail in establishing many truths in a definite manner. Not a few of the results derived were known beforehand almost as accurately as they are proved by the contents of this volume. We learn, for instance, that scientific ability is undoubtedly hereditary in some degree. Now, I should hold that such a proposition needs no new proof. It was sufficiently established in Mr. Galton's former work, and he seems as if he were always combating the objections of some imaginary opponents. I am not aware that anyone in the present day ever denies the hereditary character of personal peculiarities. Hardly is the infant ushered into the world than the nurse and the admiring relatives begin to discover the features of the father, or mother, or uncles, or aunts. Mr. Galton writes as if he were making a discovery whenever he attributes the character of a man to his descent. He says: "I have numerous returns, in which the writer analyses his own nature and confidently ascribes different parts of it to different ancestors. One correspondent has ingeniously written out his natural characteristics in red, blue, and black inks, according to their origin—a method by which its anatomy is displayed at a glance." I should have thought, however, that there was nothing novel in such analysis. Every family of intelligence must frequently have discussed the descent of characteristics, features, or diseases. We cannot hear that a youth has turned out badly without inquiring into the way in which the bad strain came into the family. What we really want are accurate estimates of the comparative power of heredity and education in shaping the character, and such results we hardly obtain.

Mr. Galton gives, indeed, the number of notable relatives of each grade which scientific men on the average possess. Thus, 100 scientific men have 28 notable fathers, 36 brothers, 20 grandfathers, and 40 uncles. It is curious that this series of numbers closely corresponds to what Mr. Galton obtained with regard to divines in his former work; but the falling off in the ability as we proceed from a distinguished scientific man to his distant relatives is less rapid, compared with his previous results, as the

distance of the kinship increases. The influence of the paternal and maternal lines is found to be approximately equal. Thus, 100 scientific men have 34 distinguished relatives on the paternal side, and 37 on the maternal side.

The greater part of Mr. Galton's present work consists of a discussion concerning the mental characteristics and education of scientific men and their parents, and it is full of interesting particulars. We have many returns showing that the energy, both bodily and mental, of these men, is above the average in their own opinion. Not a few correspondents describe with evident pleasure their feats of strength:—

"Travelling almost continually from 1846 up to the present time. Resiless. All life accustomed to extremely rough travel: often months without house or tent." "Strong when young—walked many a time fifty miles a day without fatigue, and kept up five miles an hour for three or four hours." "At the age of twenty-six, during fourteen days, was only three hours per night in bed, and on two of the nights was up all night." "I seem to possess the same unweariedness as my father, and find myself trotting in the streets as my father used to do." "At the age of sixty made a tour, chiefly pedestrian, of four weeks in the Alps. . . . Et. 67, grouse shooting and deer stalking."

Such are a few of the very abundant statements showing that great power of work is a general characteristic of successful scientific men. Forty-two instances are adduced of energy above the medium, and only two men complain of the want of energy. It may perhaps be objected that such results hardly tell us more than we might have expected to hold true of any group of remarkable men. As a general rule men do not become eminent in the eyes of their contemporaries until they have lived a good long life, and done a considerable amount of work. I do not find that Mr. Galton gives us the average age of his correspondents, but half of them are stated to be between fifty and sixty-five years old, and many who speak of their great energy are very old men. If we inquired into the energy and power of work of all the Lord Chancellors or Attorney-Generals, we should doubtless find it very high, simply because a man cannot be a successful lawyer unless he can stand much work. We get from such inquiries, so far as I can see, no estimate of the comparative influence of quality and quantity of work. *Cæteris paribus*, the great worker has the odds in his favour if he can live and work long enough. Where, however, is the account of those who fall out and perish on the way? Where, too, is the account of the energetic men who, finding their first efforts in science less esteemed than they expected, devote their energies to some other career? When Mr. Galton proceeds, as I am glad to infer that he is doing, to investigate the antecedents of other classes of distinguished men, he will doubtless find that successful physicians are also men of great energy; but where is the estimate of that subtle tendency which leads the energy into scientific study rather than practical life?

Perhaps the most interesting and immediately important part of the book is that in which Mr. Galton discusses the education of his selected men, and their own remarks as to its excellence or defects. We find that thirty-two men complain of a narrow education. Several

of them make very strong remarks on the loss of time in classical studies:—"Enormous time devoted to Latin and Greek, with which languages I am not conversant." "Omission of almost everything useful and good, except being taught to read. Latin! Latin! Latin!" "Latin through Latin—nonsense verses." "In an otherwise well-balanced education, three years . . . were spent on Latin and Greek—a blank waste of time." Many complain of the want of mathematical training, and others deplore the omission of natural science. Two or three, on the other hand, think that a too exclusively mathematical training at Cambridge was injurious to them. There is, in fact, a very strong concurrence of opinion in favour of a varied education. Out of eighty-seven answers, ten distinctly praise the width, and thirty-two deplore the narrowness of their training, while others of the answers more or less imply a similar view.

This result seems to me of great importance as regards the vexed question of the London University Matriculation Examination. It is commonly objected that the University expects candidates to get up an impossible, or at least injurious, number of subjects—dead and living languages, history, mathematics, physical science, applied mathematics. The whole circle of the sciences and arts has to be studied in one style or another by the luckless candidate of sixteen years of age, before the University will admit him to have a place in its books. But if our object is to produce conspicuously useful men, Mr. Galton's book supplies strong evidence that this wide range of study is approved by those who look back upon their early education. We must remember, too, that even those who condemn the devotion of time to Latin or Greek form no fair specimen of people in general. Conspicuous ability in one direction is not infrequently conjoined with inaptitude for other studies. If Mr. Galton interrogates eminent scholars, he is hardly likely to find the same severe condemnation of grammar. Moreover, much depends upon the way in which languages are taught. The mere grammar-school method of drilling grammar into the mind by rote may repel those who would be deeply interested by a more scientific method of teaching.

Language is rapidly becoming one of the most extensive and instructive fields for strictly scientific investigation. We can never too strongly and frequently protest against the evident tendency to interpret science as meaning *physical science*, whereas in the immediate future, if not in the present day, there are wider and more important fields for the application of scientific method in human than in external nature.

Some of those who are so strongly advocating the efficacy of physical science would do well to take note of the fact that few of Mr. Galton's picked-men advocate study of physical sciences at all in a conspicuous way. Judicious mathematical training and a rational mode of teaching modern languages are advocated almost equally with the sciences of observation.

"Omission of mathematics, German, and drawing." "Want of education of faculties of observation; want of mathematics and of modern languages." "Neglect of many subjects for the attainment of one or two." "Want of the modern languages and of chemistry." "Want of logical and mathematical training." In these

and many other replies too long to quote, the correspondents carefully couple two or more branches of study together in their recommendations. Very few complain that their education was too general and desultory, and one of these adds that it nevertheless "gave wide interest." It is worthy of notice that a large proportion of those who praise their education were brought up in Scotland.

The conclusions which Mr. Galton adopts as to the best course of education according to the opinion of his correspondents are as follows:—"To teach a few congenial and useful things very thoroughly, to encourage curiosity concerning as wide a range of subjects as possible, and not to over-teach." This nearly coincides with the saying attributed to De Morgan, that a good education consists in teaching "everything of something, and something of everything." But when Mr. Galton describes the best curriculum as compounded of mathematics, logic, observation, theory and experiment in at least one branch of science, accurate drawing, and mechanical manipulation, he seems to underrate the degree in which the study of modern languages was advocated. Mr. Galton would leave these languages to be picked up in the vacation "in the easiest and swiftest manner, with the sole object of enabling the learners to read ordinary books in them." There are, I think, very few boys who would learn any but their native tongue in this way. Most people will hold that languages should be substituted for mechanical manipulation in the school course, and that a boy may safely be left to teach himself carpentering, or other mechanical pursuits, if he only be supplied with a good set of tools.

It is of course impossible adequately to notice, in the limits of an article, the contents of a book which is far more interesting in its details than in its general conclusions. I should have liked to discuss Mr. Galton's investigation of the "origin of taste for science" in his correspondents. We find that a considerable preponderance of men believe that they had an innate taste or tendency towards science. No less than fifty-nine of them make distinct statements to this effect. In other cases, fortunate accidents, opportunities, professional influences, encouragement at home, the influence of teachers or friends, are mentioned as the determining or contributing causes. The reader who carefully studies the interesting answers elicited by Mr. Galton will probably agree with him that they are reliable as far as they go, but it is impossible to suppose that they allow of a real analysis of the causes of scientific taste and zeal. As Mr. Galton remarks, the *fortunate* accidents referred to by some correspondents will generally indicate the previous existence of a tendency, for similar accidents are continually happening to thousands of other persons without any similar effects. Are there not multitudes, again, encouraged by their parents, friends, or teachers, incited by the prospect of pecuniary advantage, or otherwise influenced towards science, who nevertheless do not yield, or, if yielding, never attain great success? A further great difficulty consists in distinguishing between the origin of great general ability and the circumstances which throw that ability into a particular groove of study. One correspondent says that his taste for botany is not innate. "I trace the origin of my botanical tastes to leisure; to

the accidental receipt of De Candolle's 'Flore française' whilst resident in that country; and to encouragement from my mother." These accidental circumstances may have bent the twig, but was there not a vigorous hereditary power of growth which enabled that twig to develop itself?

In some cases it may well be doubted whether a correspondent has not mistaken the effect of imitation and friendly encouragement for innate tendency. One geologist writes as follows:—"Decidedly innate as regards coins and fossils. My father and an aunt collected coins and geological specimens, and I have both coins and specimens which have been in my possession since I was nine years old." He apparently thinks that the love of fossils and coins was an hereditary instinct, which would be a truly remarkable instance of heredity. But is it not much more likely that the instinct was that collecting instinct so strongly manifested among the youth of the present day as regards postage-stamps, and which seems to be a kind of abnormal development of the love of property which has been growing in the human race for several thousands of years? The passion for collecting often leads to the study of the objects collected, as is testified by several correspondents; and in this particular case there must have been a further influence in the examples of the father and aunt.

An objection which may be in some degree urged against Mr. Galton's results is the insufficient number of instances which can be adduced in any one branch of science. Granting that one hundred cases is enough for the drawing of an average, we must yet remember that the hundred include men of such different pursuits as abstract mathematicians, naturalists, botanists, practical chemists, statisticians. The kind of intellectual power which makes a man eminent in one branch may be very different from what is most conducive to eminence in another branch. Mathematical power is probably much more a gift of nature than interest in statistics. In treating the origin of taste for science Mr. Galton does classify his correspondents according to the branches of science recognised in the sections of the British Association, but in regard to education he makes no such division. Now, if the division be made, the instances in most of the branches become too few to give a satisfactory average; whereas if the division be not made, it may be objected that we are averaging results which are not drawn from a uniform basis. The correspondents who supplied answers capable of being utilised did not much exceed one hundred, which is really too small a number when spread over nine different regions of science. The body of scientific men can hardly be considered so homogeneous as would be an equal number of artists, or musicians, or engineers, or bankers of eminence.

The interest and value of Mr. Galton's results would have been much greater had we similar results concerning other groups of men to compare with them. The inquiry ought, in fact, to have been conducted on the differential method, and directed to disclose the peculiarities of scientific men as contrasted with men in general, or with widely different groups. The labour of the inquiry must have been great as it is, and it may seem a heartless thing to say that Mr. Galton should have made it many times greater. But there would have been many advantages in

collecting the fresh and unbiassed opinions of eminent men in many walks of life, not only of artists, musicians, engineers, but eminent lawyers, judges, administrators, scholars, divines. No doubt it is possible that some of these classes would have failed to appreciate the necessity for answering the queries addressed to them, and the answers might have proved scanty; but, if obtained, the comparison must have afforded most interesting results.

Though I have spoken of Mr. Galton's conclusions as being in some degree disappointing, it ought not for a moment to be supposed that they are not worth the trouble incurred by the investigator and his correspondents. It is the extreme difficulty of the problem attacked which makes Mr. Galton's efforts seem less successful than some might have expected. The origin of genius or conspicuous success is the last thing which will be explained in the long progress of science. All that ought to have been expected was that Mr. Galton might form some comparative estimate of the several component tendencies which usually contribute to its production. If we look to practical conclusions, the inferences to be drawn from the answers concerning education are alone worth all the labour spent upon the book. The fact that about a hundred of the leading scientific men of the day are mostly in favour of a wide and varied range of studies in the school and college curriculum, seems to me a conclusion of great significance.

W. STANLEY JEVONS

### GREEN'S "HISTORY OF THE ENGLISH PEOPLE"

*A Short History of the English People.* By J. R. Green, M.A., Examiner in the School of Modern History, Oxford. With Maps and Tables. (London: Macmillan and Co., 1874.)

WE deem this work to come within the province of a scientific journal for two reasons:—First, Mr. Green, so far as we know, is the first who, throwing aside with just contempt the "drum and trumpet" method of writing history, has attempted to trace the various influences or forces that have combined to mould the English people and make them what they are at the present day; second, because he has noticed in detail certain important episodes in the history of English science. The only work we know of that approaches in plan the history of Mr. Green is Knight's "Pictorial History of England;" but it is only on the surface that any resemblance exists. Knight's history is divided into sections, each of which deals with one of the various ways in which English energy has found scope—in politics and war, in literature and science, in commerce, agriculture, religion, and social life; but no attempt whatever is made to show the result of the combined influence of the forces acting and reacting through these departments on the English people as a whole. In reality, the distinction drawn between these various spheres of human energy is as arbitrary as the distinction between ancient and modern history; one might as well attempt to show the resultant of any number of physical forces, by attending separately to the action of each, without paying any heed to their action in combination. Mr. Green deserves all the credit due to the originator of a bold and happy idea, and still greater

credit for having worked out this idea with marvellous success. His history he calls a "short" one, but in the space of his 800 pages we venture to say he conveys a fuller and juster idea of the progress of the English nation than any previous author has done; nay, in very few instances has the whole life of any one period been more clearly and adequately set forth than will be found to be the case in these pages.

"At the risk," Mr. Green says in his preface, "of sacrificing much that was interesting and attractive in itself, and which the constant usage of our historians has made familiar to English readers, I have preferred to pass lightly and briefly over the details of foreign wars and diplomacies, the personal adventures of kings and nobles, the pomp of courts, or the intrigues of favourites, and to dwell at length on the incidents of that constitutional, intellectual, and social advance in which we read the history of the nation itself. . . . I have restored to their place among the achievements of Englishmen, the 'Fairie Queen' and the 'Novum Organum.' I have set Shakspeare among the heroes of the Elizabethan age, and placed the scientific inquiries of the Royal Society side by side with the victories of the New Model."

Mr. Green begins his history in "Old England," as he happily calls Sleswick, the fatherland of the English people; and with charming clearness and simplicity and well-sustained enthusiasm, traces step by step their ever-widening development from the time the original conquering colonists landed in Kent down to the present century. Mr. Green's power of discovering and bringing into bold relief the true causes of events, and of exhibiting in few and telling words the real characters of the multitude of actors that have played their busy parts on the restless stage of English history, is rare. We can only repeat that his work is the only existing history of England that has been written on anything like scientific principles.

Throughout his work Mr. Green gives prominence to the intellectual development of the people; in an interesting section on the Universities, in chap. iv. (1215—1217), in connection with the origin and growth of Oxford, a masterly sketch is given of the life and work of Roger Bacon, and the premature birth of English scientific research. Again, in a chapter on "the Revolution," a more detailed and thoroughly intelligent account is given of the scientific work of Francis Bacon, and of the "Beginnings of English Science," including the birth of the Royal Society. These sketches show that Mr. Green has not only mastered his authorities, but is also perfectly competent to trace the various stages by which science has attained its present all-important position. And, as the world progresses, historians of this class will be more and more in demand, for if things hold on in their present course, it will become more and more clearly recognised that the only satisfactory history of a people is the history of the growth of science, in its widest sense, among that people.

As an example of Mr. Green's method and style, we quote the paragraph, in connection with Francis Bacon, on the "Beginnings of English Science":—

"It was this lofty conception of the position and destiny of natural science which Bacon was the first to impress upon mankind at large. The age was one in which knowledge, as we have seen, was passing to fields of inquiry which had till then been unknown, in which Kepler and Galileo were creating modern astronomy, in

which Descartes was revealing the laws of motion, and Harvey the circulation of the blood. But to the mass of men this great change was all but imperceptible; and it was the energy, the profound conviction, the eloquence of Bacon, which first called the attention of mankind as a whole to the power and importance of physical research. It was he who by his lofty faith in the results and victories of the new philosophy nerved its followers to a zeal and confidence equal to his own. It was he who above all gave dignity to the slow and patient processes of investigation, of experiment, of comparison, to the sacrificing of hypothesis to fact, to the single aim after truth, which was to be the law of modern science. But, in England at least, Bacon stood—as we have said—before his age. The beginnings of physical science were more slow and timid there than in any country of Europe. Only two discoveries of any real value came from English research before the Restoration; the first, Gilbert's discovery of terrestrial magnetism in the close of Elizabeth's reign; the next, the great discovery of the circulation of the blood, which was taught by Harvey in the reign of James. But apart from these illustrious names, England took little share in the scientific movement of the Continent; and her whole energies seemed to be whirled into the vortex of theology and politics by the Civil War. But the war had not reached its end when a little group of students were to be seen in London, men 'inquisitive,' says one of them, 'into natural philosophy and other parts of human learning, and particularly of what hath been called the New Philosophy . . . which from the times of Galileo at Florence, and Sir Francis Bacon (Lord Verulam) in England, hath been much cultivated in Italy, France, Germany, and other parts abroad, as well as with us in England.' The strife of the time indeed aided in directing the minds of men to natural inquiries. 'To have been always tossing about some theological question,' says the first historian of the Royal Society, Bishop Sprat, 'would have been to have made that their private diversion, the excess of which they disliked in the public. To have been eternally musing on civil business and the distresses of the country was too melancholy a reflection. It was nature alone which could pleasantly entertain them in that estate.' Foremost in the group stood Doctors Wallis and Wilkins, whose removal to Oxford, which had just been reorganised by the Puritan Visitors, divided the little company into two societies. The Oxford society, which was the more important of the two, held its meetings at the lodgings of Dr. Wilkins, who had become Warden of Wadham College, and added to the names of its members that of the eminent mathematician, Dr. Ward, and that of the first of English economists, Sir William Petty. 'Our business,' Wallis tells us, 'was (precluding matters of theology and State affairs) to discourse and consider of philosophical inquiries and such as related thereunto, as Physics, Anatomy, Geometry, Astronomy, Navigation, Statics, Magnetics, Chymicks, Mechanicks, and Natural Experiments: with the state of these studies, as then cultivated at home and abroad. We then discoursed of the circulation of the blood, the valves in the *vena lactea*, the lymphatic vessels, the Copernican hypothesis, the nature of comets and new stars, the satellites of Jupiter, the oval shape of Saturn, the spots in the sun and its turning on its own axis, the inequalities and selenography of the moon, the several phases of Venus and Mercury, the improvement of telescopes, the grinding of glasses for that purpose, the weight of air, the possibility or impossibility of vacuities, and nature's abhorrence thereof, the Torricellian experiment in quicksilver, the descent of heavy bodies and the degree of acceleration therein, and divers other things of like nature.'

"The other little company of inquirers, who remained in London, was at last broken up by the troubles of the Second Protectorate; but it was revived at the Restora-

tion by the return to London of the more eminent members of the Oxford group. Science suddenly became the fashion of the day. Charles was himself a fair chemist, and took a keen interest in the problems of navigation. The Duke of Buckingham varied his freaks of rhyming, drinking, and fiddling, by fits of devotion to his laboratory. Poets like Denham and Cowley, courtiers like Sir Robert Murray and Sir Kenelm Digby, joined the scientific company to which in token of his sympathy with it the king gave the title of 'The Royal Society.'

The maps, and without maps no history ought to be tolerated, will be found greatly useful. Should Mr. Green utilise the large amount of material he must have collected for the purpose of writing a similar history on a much larger scale, no doubt he will say something about the physical environment of the English people,—those external conditions which have had their own share in shaping the history and character of our nation. His present work ought to become the school history of England.

*FEHLING'S NEW CHEMICAL DICTIONARY*  
*Neues Handwörterbuch der Chemie. Unter Mitwirkung von Bunsen, Fittig, Fresenius, &c. Bearbeitet und redigirt von Dr. Hermann v. Fehling, Professor der Chemie in Stuttgart. Erster Band. (Braunschweig: Druck und Verlag von Friedrich Vieweg und Sohn, 1874.)*

TEN years have passed since the completion of the great work of Liebig, Poggendorff, and Wöhler, the "Handwörterbuch der Reinen und Angewandten Chemie." These years have witnessed great changes in our chemical knowledge; not only have theories which in the year 1864 occupied but an inferior place in the general system of chemistry now come to the front, but also a vast array of new facts demands a place in the system, which must therefore be extended so as to include them all.

The book which ten years ago was looked upon by all as a standard authority has now necessarily become somewhat antiquated, and the desire for a new edition has naturally arisen in the minds of the German chemists. The first fruits of this desire we have now in the goodly volume of 1,200 pages which lies before us.

As in most of the productions of the German mind, so in this, there is no lack of thoroughness, nor of breadth of view and treatment of the subject. The names of the contributors of the various articles are alone sufficient to inspire trust in what they have to tell us. A few of that old band of chemists who made the first *Handwörterbuch* famous still lend their aid to the success of the present volume; while among the younger men are Fittig, Kekulé, Hofmann, Victor Meyer, Tollens, Zincke, and others, who have already made for themselves a name in science.

Whether this be the proper time for the publication of a large and all-embracing treatise on chemistry is perhaps a question which admits of more than one answer. Chemical theories at present seem to be nearing that stage at which they are to be embraced within the larger theories of mechanical science. If this be true, the interpretation to be put upon chemical facts will in some years be greatly modified, and hence the publication of somewhat elaborate treatises will be demanded. In such a

volume, however, as this, we have the material out of which the chemist of the future will elaborate his general theory of chemical action; and not only this, but we have a storehouse from which the student of our science may draw rich supplies of knowledge, and to which he may always refer, well assured that he will not be sent away empty.

The arrangement of the new *Handwörterbuch* is very similar to our own "Watts' Dictionary." Amid the variety and excellence of the articles, it is difficult to choose any for special mention.

The articles on Equivalents and Atoms are especially to be commended, the former by Prof. Kekulé, the latter by Prof. Fittig. In the former article the author defines the correct and true meaning of the word "equivalent"; he shows how vague oftentimes are the grounds upon which we pronounce that such a substance is equivalent to such another, and he clearly points out the great advantages possessed by the modern atomic notation as compared with the old and vague so-called equivalent notation.

In the article on Atoms we have a clear and succinct account of the modern chemical theory, and an interpretation of the way in which the older ideas of equivalency are applied to the newer atomic doctrines.

The articles on Analysis are generally full and satisfactory. It is strange, however, that such an excellent method of qualitative testing as that presented by "Bunsen's Flame Reactions" should be overlooked.

There are excellent monographs on Aniline and Benzol, by Prof. Hofmann and Zincke respectively; while on such subjects as the Respiration of Animals and Plants, and Zoö-chemistry in general, we have articles from the pen of Prof. v. Gorup-Besanez. The woodcuts are admirable; in this respect the German work is far ahead of our English Dictionary. Let us hope that the work will be completed as promised in the prospectus, and that the volume already published will not add another to the already too long list of great German scientific works the opening volumes of which stand waiting for their successors, but seemingly waiting in vain.

M. M. PATTISON MUIR

#### OUR BOOK SHELF

*Die fossilen Bryozoen aus österreichisch-ungarischen Meeres.* Von Prof. Dr. A. E. Ritter von Reuss. I. Abtheilung. Pp. 50. 4to. (Wien: 1874.)

*Geologischer Bau der Insel Samothrake.* Von Rudolf Hoernes. Pp. 12. 4to. (Wien: 1874.)

THESE publications are extracted from the Transactions of the Imperial Academy of Sciences. Dr. v. Reuss's paper describes the Salicornaridae, Cellularidae, and Membraniporidae, a number of the species being new; and gives twelve excellent plates of the fossils. According to Herr Hoernes, the island of Samothraki consists of abrupt hill-masses of ancient crystalline rocks, such as granite, clay-slate, hornblende rock, &c., overlaid, especially in the north-west and north, with deposits of Eocene age, and diluvial and recent accumulations. A coloured sketch-map accompanies the paper.

*Über die paläozoischen Gebilde Podolins und deren Versteinerungen.* Von Dr. Alois v. Alth. Erste Abtheilung. Pp. 78. (Wien: 1874.)

*Über die triadischen Pelecypoden-Gattungen, "Daonella" und "Halobia."* Von Dr. E. Mojsisovics v. Mojsvár. Pp. 38. (Wien: 1874.)

BOTH these publications are issued by the Austro-Hun-

garian Geological Survey, being extracted from the "Abhandlungen, Band vii." This mode of republishing in a separate form the papers contributed to their Transactions cannot be too strongly commended. Dr. A. v. Alth's paper relates to the region which lies between the rivers Bug and Dnieper. It is illustrated by five lithographic plates of fossils, a number of which are new species of Pteraspis, Scaphaspis, Cyathaspis, Beyrichia, &c. Dr. Mojsisovics' paper is also illustrated by five lithographic plates of a number of new species of the genera Daonella and Halobia, which are described and named by himself.

#### LETTERS TO THE EDITOR

[The Editor does not hold himself responsible for opinions expressed by his correspondents. Neither can he undertake to return, or to correspond with the writers of, rejected manuscripts. No notice is taken of anonymous communications.]

#### On the Inventor of Clock Movement applied to Equatorials.—Suom Quique

IN a pamphlet by Col. Laussedat, "On the Horizontal Astronomical Telescope," in which he claims for himself the invention of applying a heliostat to direct the light of any object into a fixed telescope, I find at p. 2 this statement in speaking of the equatorial: "The idea of so endowing a telescope with a moving power which annuls, or, to speak more exactly, compensates the motion of the earth, is due to a French watchmaker of the last century, named Passemont."

I am sure the distinguished writer would not knowingly have done to another the injustice of which in his own case he complains; but in fact this invention belongs to a much earlier date, and to one of far greater fame, the illustrious Robert Hooke, who describes it, with a figure, in his "Animadversions on the Machina Cœlestis of Hevelius" (my copy bears date 1674). It was primarily intended to facilitate the process of measuring directly the distance of two stars, a process which was then much in vogue, but which must have been very troublesome from the difficulty of following them. It consists of a strong polar axis, adjusted at its lower bearing by screws, and carrying at top a cross arm, one end of which bears a counterpoise, and the other a quadrant or sextant with a ball-and-socket support, by which its plane can be made to coincide with that passing through two stars. But Hooke expressly stated that a telescope may be similarly attached there. The polar axis carries an octant whose limb is ratcheted, and driven by a screw connected with a clock. The clock is regulated by a conical pendulum; and he describes the mode of altering its rate for the sun, moon, and planets. Of the date or details of M. Passemont's re-invention there is no trace in Laalande. But, as I find in Rees' Cyclopædia (art. "Passemont") that he was born in 1702, and that his first publication appeared in 1738, it is by at least half a century later than Hooke's.

It also deserves notice that Col. Laussedat's invention is described by Hooke in his treatise on Heliostats two years later (1676). His words are: "I explained at the same time to the Royal Society several other ways of facilitating the use of very long glasses for other objects in the heavens (he had been speaking of the sun) by the help of one reflecting plane only, and that was by a tube fixed either perpendicularly, horizontally, or obliquely; for it mattered not, whether as to the seeing the object in any part of the heaven, and the object could be as easily found as by the common telescope of the same length. But of these elsewhere."

I have not, however, been able to find any further notice of it in his works.

This invention leads me to a suggestion which may be interesting to astronomers. The Royal Society possesses two Huyghenian object-glasses, one of 120 feet focal length, the other of 200. Some years ago a question was raised by M. O. Struve as to the defining power of the first-named of these, in reference to a discussion on the rings of Saturn, and the Society appointed a committee to examine. It was tried at the Kew Observatory, and defined a watch-dial as well as a good 3.75-inch achromatic. This was considered sufficient without incurring the great expense of such a scaffolding or building as would have been required to use it for celestial observations. These, however, can be easily managed by Col. Laussedat's arrangement. If successful, these



object-glasses would probably give matchless solar photograms. The 120-feet has 6 inches aperture, and would give a solar picture 13.4 inches diameter. R.

### The Potato Disease

I AM afraid I cannot regard the letter of your anonymous correspondent "Inquirer" as written in altogether good faith. He first misrepresents what I stated in my letter of Nov. 20, which he professes to quote, and then proceeds to ask me a question which, if he had even glanced at my letter, he would have seen was already answered.

If I beg your indulgence for some further remarks suggested by "Inquirer's" letter, I hope that they will be the last it will be necessary to make.

The number of NATURE for Nov. 19 gave what purported to be an account of the "Report of the Potato Disease Committee of the Royal Agricultural Society." It contained the following passage:—"Prof. de Bary has worked out the scientific questions that occur as to the origin of the disease. It is owing to a fungus (*Peronospora infestans*), which attacks the leaves first, and after absorbing the nutriment of them, utilises the petiole, and thus reaches the tubes" (*sic*). It appeared to me, as it did to others, that the only meaning which could be attributed to this was that we owed to Prof. de Bary all the knowledge we at present possess with regard to the disease.

I therefore thought it fair to point out in the following number "that all this and a good deal more was ascertained by the Rev. M. J. Berkeley in this country, and by Montagne in France, and published by the former in a paper contributed to the first volume of the Journal of the Horticultural Society in 1846." It is almost incredible that anyone with my letter before him should say that I had asserted "the discovery by the Rev. M. J. Berkeley of the fact that the potato disease was due to the attacks of a parasitic fungus," and should proceed to ask me for "a more exact reference to the records."

The potato disease appeared on the Continent a few years before it worked such ravages in the British Isles. The mould had been detected upon the foliage in France and Belgium, but opinion was divided as to the part it really played. And we have Mr. Berkeley's authority for asserting that even Montagne, to whom "Inquirer" attributes the discovery that the potato disease was due to the attacks of a parasitic fungus, did not support the "fungal theory."

In this country Mr. Berkeley maintained it almost single-handed against men of such weight as Lindley and Playfair. His paper, which appeared in the Horticultural Society's Journal in November 1845 (the whole volume is dated 1846), really, however, settled the matter.

It is perfectly easy to trace what Mr. Berkeley did by referring to the horticultural papers of the time. Thus, he wrote to the *Gardener's Chronicle*, August 30, 1845 (p. 593): "The malady by which potatoes are so generally affected this year, both in this country and on the Continent, does not appear to prevail in this neighbourhood. . . . I have this morning received from Dr. Montagne, of Paris, some leaves affected with the mildew. The parasite of the potato does not appear to have been observed before by systematisers." On Sept. 6 (p. 608): "You will be interested to learn that the mould upon the potatoes which you sent me is identical with that upon the leaves, and the same with what I have received from Paris. It appears, then, that the decay of the tubers is produced by the same cause which affects the leaves, viz., by the growth of a mould whose development has been promoted by excessive wet." On Sept. 20 (p. 640): "In every case I find the *Botrytis infestans* [now called *Peronospora infestans*] preceding the work of destruction."

All this is given with very full details by Mr. Berkeley in his later paper. What I wish, however, particularly to point out is that the admirable observation (contained in the words I have italicised) of the identity of the fungus which attacks the foliage with that which destroys the potatoes was made absolutely independently by Mr. Berkeley. Morren appears to have made it about the same time. It is a sufficient proof of the estimation in which his investigations were held at the time, that Montagne relinquished the intention of writing upon the subject, and transmitted his materials to Mr. Berkeley, by whom the use of them is duly acknowledged. W. T. THISELTON DYER

### Mr. Cuttall and Section Cutting

IN your number of NATURE just issued you have given an extract from the annual address of the President of the Royal

Society, in which reference is made to my labour of section cutting. It is perfectly true that I have prepared more than a thousand sections of coal plants, but it would be unfair to a very efficient auxiliary not to mention the help he has afforded me in this work. I require many sections of a much larger size than my machinery is capable of cutting, and these have been prepared for me by the skilled hands of Mr. Cuttall, of New Compton Street, London.

In each of two instances, also, I am indebted to the same experienced lapidary for obtaining three sections out of small but precious fragments, not more than from three-sixteenths to a quarter of an inch in thickness. I am anxious to recognise these services, and not to monopolise Mr. Cuttall's share of the credit for the labours to which Dr. Hooker's report refers so kindly.

W. C. WILLIAMSON

Fallowfield, Manchester, Dec. 24

### Snakes and Frogs

IN reading the letter of your correspondent, Mr. Mott, on the cry of the frog, it struck me as curious that there should be resemblances which people in countries wide apart should pitch on the same phrase to indicate. Now, there could not be a better way of conveying a sound which frequently greets one's ears in the country in Bengal during the rains, than that which your correspondent makes use of, "the cry of a new-born infant." Few residents in the country here, we take it, who have lived anywhere near jungle, will have failed to hear, and that tolerably frequent, the unspeakably plaintive wail which indicates that the remorseless ophidian has seized his prey, and that deglutition has commenced. If one be tolerably quick he may, as I have frequently done, guide himself to the very spot by the sound of the frog, and the snake will then, in his alarm and anxiety to escape, frequently let the frog go, though he as often slides off with it protruding from his mouth. We have the batrachians in great force here, and of all sizes and noises, from the great swamp frog which, as soon as the lands are drenched in the heavy rainstorms of May, commences its nocturnal bellowing, down to the bronze tree frog with gilt eyebrows that keeps up its metallic tink.

The frog is connected with some of the religious ceremonies of the country; and one may see here, as well as in Assam, the curious custom of "bathing the frogs" in a cage. This is done in time of drought to propitiate the rain god. Grain is sometimes put out on a mat to sun, and to prevent the crows from making away with it, a frog is tied by the leg to a stake; his constant hopping about acts as a deterrent to the crow. Hence the native proverb denoting vicarious and unmerited suffering, "The crow steals the grain, and the string is round the leg of the frog."

Bulderpore, Eastern Bengal

C. B.

### THE ANDERSON SCHOOL OF NATURAL HISTORY

MOST of our readers, no doubt, have heard of the School of Natural History established by the late Prof. Agassiz, in conjunction with some of his American friends, shortly before his lamented decease. The first report of the trustees of this institution, which has lately been received in this country, gives a fuller account of its foundation and subsequent progress than has yet reached us.

The plan of the school was first put forward by its originator in a circular issued in December 1872, from the Museum of Comparative Zoology at Cambridge, U.S.A. It was proposed that courses of instructive lectures in various branches of natural history should be delivered by the sea-side, at Nantucket—an American bathing-place—during the summer months, by Agassiz himself, and by other naturalists belonging either to the same institution, or to other scientific establishments in the United States, who had combined together to assist him. The object of these courses was chiefly for the benefit of teachers proposing to introduce the study of natural history into their schools, and for such students as were preparing to become teachers. Besides the lectures it

was proposed to provide a number of aquariums, as also the necessary apparatus for dredging in deep water, so that the pupils might be practically as well as theoretically instructed.

Whilst Prof. Agassiz was appealing to the public to support his beneficent scheme, the attention of Mr. John Anderson, a wealthy merchant of New York, was attracted to it. Mr. Anderson, "although not possessing himself any intimate acquaintance with natural history," "sympathised warmly" in the professor's project for making that department of science a branch of education, and in aid thereof offered to hand over to trustees for the benefit of the scheme a whole island situated in Buzzard's Bay, in Massachusetts.

We need hardly say that the munificent offer was gladly accepted, and Penikese Island, containing 100 acres of great fertility, several springs of fine fresh water, and a mansion house, constituting altogether a "most attractive location for a summer residence," became, instead of Nantucket, the seat of the proposed institution, which was appropriately named after the donor, the "Anderson School of Natural History."

A few days after the acceptance of this noble gift by Prof. Agassiz, Mr. Anderson gave a further proof of his liberality by presenting the sum of \$50,000 for the equipment and current expenses of the institution, which was thus enabled to make a start under very favourable circumstances.

When matters had progressed thus far, it was hardly in accordance with the national characteristics that much delay should take place in commencing work. So, although the island of Penikese was only presented to Prof. Agassiz on the 22nd April, 1873, a site was selected for the school, the plans were arranged, and the contract actually signed for the necessary works on the 16th May, and the 6th July was appointed for the building to be ready. In vain the architect and builder declared that it was impossible, and urged the postponement of the opening until the following year. Prof. Agassiz, perhaps with a presentiment of the future, was inflexible, and a commencement was actually made on the appointed day. During the summer a second building, containing another numerous set of working rooms and dormitories and a lecture room connecting it with the former edifice, was nearly completed, together with the interior arrangements of the whole school.

During the first session, 1873, the pupils were from forty to fifty in number, consisting chiefly of teachers (both male and female) in colleges and schools and other public institutions. Prof. Agassiz lectured nearly every day. Mr. Galloup, a citizen of Boston, sent his yacht to Penikese, and handed it over to Count Portales, who took charge of the dredging parties during the whole session. Ten or twelve of the pupils went out every day, thus obtaining instruction in the use of the implements, and at the same time obtaining many specimens for the lectures which could not have been collected from the shore.

Other efficient workers were Dr. A. S. Packard, jun., Prof. Jordan, Dr. Brewer, Prof. Wilder, and Prof. Guyot. Full instruction was thus given in various branches of natural history, in geology, in physical geography, and especially in zoology.

So successfully was this scheme carried out, that for the succeeding session a much larger number of applications than accommodation could be provided for was received, when the untimely death of the founder occurred and somewhat imperilled the continuance of his noble plans. Fortunately, a worthy son succeeded to a worthy father, and under the direction of Mr. Alexander Agassiz, the Anderson School of Natural History has, we believe, continued in its career of prosperity, although details of its second year's working have not yet reached us.

When we consider what has thus been done in the

United States, it is no slight reproach to us that nothing of the sort has been attempted in England. The great aquariums which have recently been built in several places offer unusual facilities for such an institution. But, alas! Brighton, Sydenham, and Southport are, we fear, wholly given up to ten per cent. The only counterpart of Prof. Agassiz in Europe is Anton Dohrn, whose "Zoological Station" at Naples is a worthy rival of the Anderson School of Natural History—perhaps even more complete in its organisation. We trust, however, that before long a similar scheme may be started in this country.

#### THE LAST TYPHOON AT HONG KONG

THE typhoon at Hong Kong of September 1874 is the greatest calamity that has visited the crown colony since its establishment in 1841. In each of the years 1859 and 1865 one of these desolating storms occasioned a great deal of damage to shipping in the harbour and vicinity; in 1867 two occurred, the second of which raged with great violence during the day, and was consequently observed with considerable interest; on Sept. 2, 1871, a still more striking instance is recorded;\* but the whole of these phenomena sink into utter insignificance when compared with the furious typhoon which swept over the island during the night of the 22nd and the morning of the 23rd of September last. Without speaking of the dire effects produced by the latter, tenfold more terrible than any hitherto experienced, one far more crucial test may be adduced as evidence of the truth of our assertion.

It is an admitted fact that the force of the wind during a cyclone or typhoon is always in direct proportion to the height of the mercury in the barometer. Now, the lowest reading of the barometer previously recorded at Hong Kong was during the typhoon of 1871, viz., 29.15; whilst at Macao, on the same occasion, the mercury fell to 28.39. But during the recent event, the reading at Hong Kong at 2.15 on the morning of the 23rd was 28.75 according to one barometer, and 28.73 according to another; whilst at Macao the mercury actually fell to 28!—a fall we believe to have been altogether unprecedented in the history of atmospheric reading in China. Hence we conceive this to have been one of the most severe instances, if not the severest, of a typhoon on record. The fact that the readings at Macao were lower in 1871 than at Hong Kong in 1874 does not affect the question, for, as we shall see presently, the first-mentioned place always suffers more severely than the latter, owing to the greater concentration of the power of the wind at its turning point.

Many points of interest are connected with the late typhoon. It was observed that the clock upon the clock tower at Peddar's Wharf in Hong Kong stopped shortly after two, and it has been stated upon good authority that five or six other pendulum clocks stopped at the same hour. Now, this was exactly the time when the most violent throes of wind that was experienced throughout the entire night took place; hence we are justified in assuming that, at the precise moment when the typhoon was at its height, a shock of earthquake probably occurred, pointing to the conclusion that the atmospheric disturbance induced physical disturbances in the crust of the earth. The possibility of the existence of such a condition has been argued at length by Prof. Lyell in his "Principles," where he states that the inhabitants of Stromboli are said to make use of the island "as a weather-glass," its volcanic disturbances "increasing during tempestuous weather," so that "the island seems to shake from its foundations." He considers that extreme changes in the atmospheric pressure exerted upon a vast superficial area might well be deemed to influence the confined gases and liquids interposed between the

\* See NATURE, vol. v. p. 166.

successive layers of strata. That earthquakes are the result of movement amongst these gases and liquids there seems little reason to doubt.

We gather, from the various accounts to hand, that the characteristics of the recent typhoon were very similar to those of the event of 1871, viz., that it came from an easterly quarter, and, after sweeping over Hong Kong, reached Macao somewhat later, there culminating; and, describing a portion of a circle so as to present all the appearances of a whirlwind, eventually dissipated itself along the coast upon contact with the high land. This typhoon, as might have been expected, crossed the estuary of the Pearl River from Hong Kong to Macao in less than half the time occupied by the typhoon of 1871. The distance is almost forty-five miles, and the lowest readings of the barometer were as follows:—In Hong Kong at 2.15 A.M. and at Macao at 3.15 A.M. during 1874, against 11 P.M. and 1.30 A.M. during 1871. The rate of progression in the late instance was moreover twice as great as that of the West Indian hurricanes, which has been computed at twenty to twenty-five miles per hour.

Before we dismiss the subject it may not be out of place to dwell for a few moments upon the probable causes which give rise to these "freaks of nature." At Hong Kong the S.W. monsoon blows from April to September, and the N.E. monsoon from September to April. It is during the change from S.W. to N.E. that typhoons usually occur. The theory is this. When the cold N.E. monsoon sets in suddenly it strikes upon a vast tract of land in Southern China, and on a portion of the China Sea warmed by the mild breezes of the opposite monsoon, occasioning rapid precipitation or condensation of vapours, and, as a necessary consequence, an extensive vacuum where the rarefied air formerly was. Other air then rushes violently in to fill the vacuum, and strong breezes, sometimes developing into typhoons, are the result. The mingling and collision of the various currents at their point of contact also assists the disturbance of the atmosphere. The reason of the gale as a rule blowing from the east is apparent. Inland of the coast line is a towering range of mountains, extending down to Cochin China, and effectually arresting the rush of air from that quarter. The open sea, therefore, is the only free point of access. The prevailing direction of typhoons at Hong Kong is, in point of fact, very nearly that of the N.E. monsoon just commencing, but possibly slightly diverted by the remaining influence of the opposite monsoon. Hong Kong, Amoy, and Macao being just opposite to the opening between Formosa and Luzon, the full sweep of the wind rushes in unhindered towards them from the Pacific Ocean. Macao, however, fares worst, for it is situated precisely where the typhoon is arrested by the high land of the coast. The lowest readings of the barometer are invariably therefore recorded at Macao.

#### ENCKE'S COMET

I HAVE received this morning, from the Observatory of Pulkova, copies of Dr. von Asten's ephemeris of this comet, in which the accurate effect of planetary perturbation to the approaching perihelion passage (about April 13<sup>o</sup> Greenwich time) is included. His positions differ less than five minutes of arc from those I have already communicated. The comet arrives at its least distance from the earth on the night of May 3, about which time it may be a bright object for the observatories of the southern hemisphere. In these latitudes it will probably be observed, as in 1842, to the end of the first week in April. If not detected during the next period of absence of moonlight, as I believe to be probable, there can be no doubt of its visibility before the February moon interferes.

J. R. HIND

Mr. Bishop's Observatory, Twickenham, Dec. 22

#### FERTILISATION OF FLOWERS BY INSECTS<sup>1</sup> IX.

##### *Alpine Orchids adapted to Cross-fertilisation by Butterflies*

NO family of plants, as far as is known, offers more various adaptations of flowers to insects of different orders than the Orchids, which have called general attention to the relation between flowers and insects since the admirable description by Mr. Darwin.<sup>2</sup> Of thirty-four species of Orchids found up to the present time in West-phalia, five<sup>3</sup> have been observed to be fertilised by humble-bees, and partly also by other Apidæ; two<sup>4</sup> by humble-bees and Diptera; one<sup>5</sup> by species of *Andrena*; one<sup>6</sup> by *Vespa*; one<sup>7</sup> by Apidæ, Diptera, and Sphegidæ; one<sup>8</sup> principally by Ichneumonidæ; one<sup>9</sup> exclusively by Diptera; two<sup>10</sup> by minute insects of different orders; and four<sup>11</sup> by Lepidoptera. Although the fertilisers of the sixteen remaining species<sup>12</sup> have not yet been observed, still it may fairly be deduced from the structure of their flowers that none of them, except, perhaps, *Habenaria viridis*, is fertilised by butterflies. Of thirty-four species, then, growing in the plain and lower mountain region, four, or at the most five, that is to say 12 to 15 per cent., are fertilised by Lepidoptera; whereas of five species of Orchids growing in the higher Alpine region near the Ortle, three,<sup>13</sup> or perhaps four,<sup>14</sup> that is to say 60 to 80 per cent., are adapted to cross-fertilisation by butterflies, a proportion which strongly corroborates my view that the predominant frequency of butterflies in the Alpine region must have influenced the adaptations of Alpine flowers. As two of these five species of Alpine Orchids are not mentioned in Mr. Darwin's classical work, nor have yet been described with regard to their contrivances for fertilisation, I will give here a brief account of them.

*Gymnadenia odoratissima* (Figs. 58, 59) produces its honey in a nectary only  $\frac{3}{8}$  mm. in length, but the narrowness of its entrance (cf. Fig. 59) proves it to be accessible only to butterflies. These, when inserting their proboscis into the nectary, cannot fail to attach to its upper side the two viscid discs (*d, d*) which lie close together immediately above the mouth of the nectary, and to which the pollinia are fixed by their caudicles. Hence a butterfly, when flying away from the flower first visited, bears a pair of pollinia upright on the upper side of its proboscis. When these are exposed to the air, the membranous discs to which their caudicles adhere contract (just as described and drawn by Mr. Darwin at p. 80 of his work), which causes the pollinia to move downwards and outwards in such a degree as exactly to strike the stigmatic surface when the butterfly inserts its proboscis into the nectary of a second flower.

Near the cataracts of the Adda, between the second and third Cantoniera, 2,200 to 2,400 metres above the sea-level, I found (July 14) plenty of these flowers, which, in accordance with their name, struck me by their highly attractive sweet smell; but although many butterflies were visiting a large number of the surrounding flowers, some of which were scentless, others but slightly scented,

<sup>1</sup> Continued from p. 112.  
<sup>2</sup> "On the various contrivances by which British and Foreign Orchids are fertilised by insects." London, 1862.

<sup>3</sup> *Orchis Morio*, *O. mascula*, *Epipogon Gmelini*, *Goodyera repens*, *Spiranthes autumnalis*.

<sup>4</sup> *Orchis maculata*, *O. latifolia*. <sup>5</sup> *Cyrtopidium calceolus*.

<sup>6</sup> *Epipactis latifolia*. <sup>7</sup> *Epipactis palustris*.

<sup>8</sup> *Listera ovata*. <sup>9</sup> *Neottia nidus-avis*.

<sup>10</sup> *Gymnadenis albidia*, *Herminium monorchis*.

<sup>11</sup> *Orchis pyramidalis*, *Gymnadenia conopsea*, *Platanthera bifolia*, *P. chlorantha*.

<sup>12</sup> *Orchis laxiflora*, *coriophora*, *militaris*, *fusca*, and *variegata*; *Habenaria viridis*, *Ophrys muscifera* and *aphera*; *Cephalanthera fallens*, *encyclia*, and *nigra*; *Epipactis atrorubens*, *viridiflora*, and *microphylla*; *Malaxis paludosa*, *Liparis Loeselii*.

<sup>13</sup> *Nigritella angustifolia*, *Gymnadenia odoratissima*, *conopsea*, and *albidia*; *Habenaria viridis*.

<sup>14</sup> *Nigritella angustifolia*, *Gymnadenia odoratissima* and *conopsea*, and perhaps *Habenaria viridis*.

*Gymnadenia odoratissima* remained almost entirely overlooked, some specimens of *Crambus coultonellus*, Dup.\* being the only visitors I succeeded in observing during several hours. As the possibility of self-fertilisation has been lost by the flowers of this plant, it must be supposed that its cross-fertilisation by insects happens frequently enough to make self-fertilisation useless. Therefore, from

the rare diurnal visits and from the pale colour of the flowers, I am inclined to infer that *G. odoratissima* is more adapted to fertilisation by crepuscular and nocturnal than by diurnal Lepidoptera.

A curious observation on *G. odoratissima* remains to be noticed. In this species, as in most Orchids, the labellum (*l'*, Fig. 58), properly the upper petal, assumes

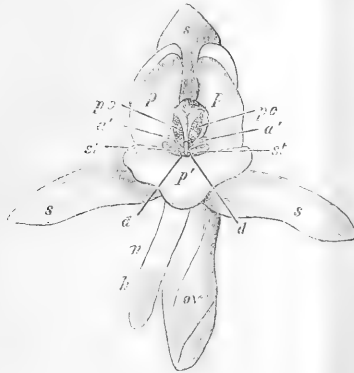

FIG. 58.—*Gymnadenia odoratissima*. Front view of the flower (7 : 1).

(*ov*, ovary; *s*, sepals; *p*, petals; *l'*, labellum; *a*, developed anther; *d*, viscid discs; *a'*, rudimentary lateral anthers; *n*, nectary; *n'*, orifice of the nectary; *h*, honey.)

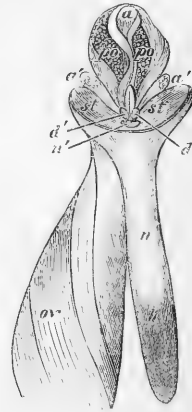

FIG. 59.—Front view of the same flower (1/4 : 1), with all the sepals and petals removed except the nectary.

its position as the lower lip by the torsion of the ovary; but in some specimens which I found, the torsion of the ovary had stopped half way in all the flowers, so that they occupied a transverse position, directing the labellum and the nectary to the right hand, one of the sepals downwards, the other upwards. A slight approximation to this position is shown by Fig. 59 if compared with

Fig. 58. This exceptional imperfection of the torsion of the ovary of *G. odoratissima* seems to me to be of some interest, if we compare it with the normal condition of the flowers of *Nigritella angustifolia* (Figs. 60-62), in which the ovary is not at all twisted, so that the flowers occupy just the contrary position to what they do in other Orchids. In consequence of this also the function of the upper and



FIG. 60.—*Nigritella angustifolia*. Perfect flower viewed laterally, with the labellum (*l'*) in its natural position, upwards (3 : 1).

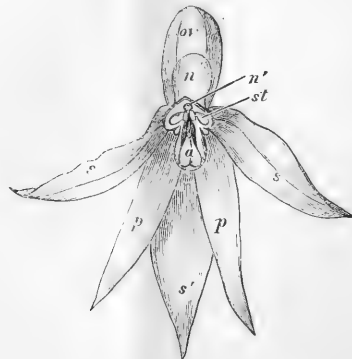

FIG. 61.—The same flower viewed in front, with the labellum removed (7 : 1).

All letters have the same significance in Figs. 60, 61, 62, as in Figs. 58, 59. By the dotted line in Fig. 62 the limit of the honey is marked.

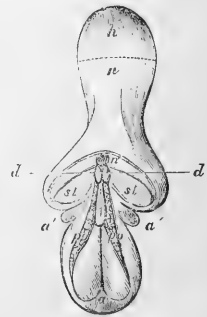

FIG. 62.—Sexual organs and nectary of same flower, in their natural position.

lower sepals and petals is inverted; the labellum (*l'*), being turned upwards, here protects the organs of fructification, and the sepals and petals opposite to the labellum (*s'*, *p'*, Fig. 61) afford a landing-place for insects. When a butterfly inserts its proboscis into the narrow entrance

\* According to Dr. Speyer's determination.

of the nectary (*n'*, Figs. 61 and 62), it attaches the viscid discs (*d*, Fig. 62) to its under side; and when it flies away, the pollinia, in consequence of the drying up of the discs to which they are affixed, undergo an upward and outward movement so as to strike the stigmatic surface of the flower next visited. *Nigritella* has probably in-

herited the peculiar position of its flowers from the ancestors of the family of Orchids, which undoubtedly, like the most nearly allied families, possessed an untwisted ovary, and the imperfectly twisted condition of the ovaries of some individuals of *G. odoratissima* may be looked at as an effect of atavism.

*Nigritella* differs from *Gymnadenia odoratissima* in the position of its flowers, and in being fertilised in the daytime. Whilst the latter seems to be fertilised especially by crepuscular and nocturnal Lepidoptera, the former, on the contrary, is easily seen to be fertilised by diurnal butterflies. In contrast to the pale flowers of *G. odoratissima*, those of *Nigritella* are of a dark purple red colour, shining magnificently in the sunlight, whilst at the same time they exhale so remarkable a vanilla-like odour that I have more than once recognised this species sooner by smell than by sight. I have never met with any other flower which attracts diurnal Lepidoptera more efficaciously than this. When descending from the pass of Fluella, towards Zernetz (July 9), during about an hour I collected in a small locality the following species, having observed them all fertilising the flowers of *Nigritellas*. (a) Rhopalocera: (1) *Lycana semiargus* Rott., frequently; (2) *Melitica Athalia* Rott.; (3) *Argynnis Euphrosyne* L.; (4) *Hesperia serratala* Ramb. var.? (b) Sphingide: (5) *Ino statice* L., Alpine varieties, in great number. (c) Noctuae: (6) *Agrotis ocellina* W. V., several specimens; (7) *Prothymia anca* W. V. (d) Crambina: (8) *Botys aërealis* Hb., var. *opacalis* H.; (9) *Diasemia littorata* Scop., in great number; (10) *Crabum dumetellus* H., var., very frequently. (e) Tinea: (11) *Butalis* species.\* In the subalpine region round "Quarta Cantoniera," besides Nos. 3 and 5, I observed (12) *Melitica Parthenie* Bkh., var. *varia*; (13) *Zygana exulans* Reiner, both not only perseveringly seeking for the honey of *Nigritella* in the sunshine, but also lodging after sunset in the heads of their favourite flower, from which in the evening and morning numerous individuals could easily be taken off which had been killed or numbed by the cold.

HERMANN MÜLLER

### THE TRANSIT OF VENUS

DURING the past week a few additional telegrams have appeared in the *Times*; these, with the *Times*' notes upon them, in a condensed form, we give here.

From the Hague we learn that the Government has received advices from the Dutch expedition sent to Réunion for observing the Transit of Venus. The sky being cloudy, the expedition was only partially successful.

The Astronomer Royal has received the following telegram from the Sandwich Islands:—

"Transit of Venus well observed at Honolulu and Atooi; cloudy at Owhyhee. Sixty photographs; Janssen failed; internal contact uncertain several seconds; complete disc of Venus seen twelve minutes before; 120 micrometer measures."

From New York intelligence has been received that the observation of the Transit of Venus made by the British astronomical party at Honolulu has been successful, except as regards the photographs, which failed.

It will be seen that the bad news for the English plans from New Zealand is fortunately not followed up from the Sandwich Islands. There the ingress, at one end of a base line stretching to Kerguelen's Land, has been secured, and if the observations have been successful at the latter place, Delisle's method can be applied for the ingress.

The telegram from New York is enough to give rise to some uneasiness. The first telegram stated that the Transit was well observed at Honolulu and Atooi, while there were clouds at Owhyhee; and then followed

some statements which might have applied either to Owhyhee solely or to the whole attempt. From the last telegram we learn that the photographs failed at Honolulu, where in the telegram to the Astronomer Royal it was stated that the Transit had been well observed. There is, therefore, a distinct strengthening of the idea that the remarks "Janssen failed," "internal contact uncertain several seconds," apply to all the stations. We sincerely trust this may not be so, for, the whole value, to the English plans, of the occupation of Kerguelen's Land is that observations of ingress may be made there to correspond with those made in the Sandwich Islands,—the ingress being accelerated in these latter and retarded at Kerguelen. A long experience with transits of Mercury and solar eclipses has now convinced astronomers that corresponding observations mean observations made by similar instruments under similar conditions. For instance, it will be useless to compare an eye observation of a contact made at the Sandwich Islands with photographs of the contact made by Janssen's beautiful contrivance at Kerguelen, whence we are not afraid of hearing that "Janssen failed," for Father Perry, in whose charge the revolving apparatus is, is one of the very few men long practised with astronomical instruments who form part of the English staff.

Lord Lindsay telegraphs to Lady Lindsay from the Mauritius:—

"Transit observed; last half satisfactory. Good photographs, measures, and time determination. Altogether well satisfied."

The private expedition of Lord Lindsay to the Mauritius deserved to succeed. We regret that the degree of success obtained is not so high as that which Lord Lindsay's energy, skill, and care had merited. Had observations been secured here and at Réunion at the commencement of the Transit, both Mauritius and Réunion would have been Delislean stations for observations of ingress—almost, indeed, as good as Kerguelen's Land, where it is to be hoped the official astronomers have obtained observations to pair with those made at the Sandwich Islands. But, as Lord Lindsay saw nothing of the beginning (ingress), and as the sky was cloudy at Réunion, the parties at Kerguelen's Land are now the only hope of the Delisleans, and this makes one regret all the more that the Americans were foiled in their attempt to occupy the Crozets. But Lord Lindsay's hopeful telegram evidently means that he has obtained enough photographs and measures to employ with advantage the direct and heliometric methods of determining the least distance of centres; these methods being precisely those which the German parties, also in the Mauritius, were to employ, obtaining corresponding observations at Chefoo, in the north of China.

The *Times* Malta correspondent writes under date Valetta, Dec. 15:—"The Transit of Venus was distinctly witnessed at Malta on the 9th inst. The external egress of the planet from the sun occurred precisely at 7:26 A.M. local mean time."

"Melbourne, Dec. 29.—Intelligence from New Zealand announces that the American astronomer, Prof. Peters, was successful in his observation of the Transit of Venus. The German expedition to the Auckland Isles also achieved satisfactory results."

### THE SPECTROSCOPE AND THE TRANSIT OF VENUS

A RECENT article in the *Times* (Dec. 24) speaks of the application of the spectroscope to the observations of transits; it is so much to the point that we reproduce a portion of it here:—

The news from Malta which we gave yesterday of the unhoped-for observation of external egress there under

\* For all the names I am indebted to Dr. Speyer, of Rhoden.

good conditions, coupled with the further information which we published on Tuesday, detailing the care taken at Jassy to insure the accuracy of the observation of external contact at egress by Doctors Weiss and Oppolzer, furnishes a good opportunity of referring to the whole question of such contacts, and of pointing out an almost general omission in the scheme of observations.

A few general considerations will show how, in the opinion of some competent judges at all events, there is a remedy for such a state of uncertainty as we have described in the case of external contacts. We have first the essential consideration which underlies the various methods of utilising a transit, that when Venus is as near to us as she is on the occasion of a transit—Venus, of course, is always nearest to us when she is between us and the sun—unless she be exactly between us and the sun, so that we can use the sun as a screen or background, and see Venus moving like a black spot upon it, she will not be visible to us at all, as her bright side will be turned away from us. To point this statement we may remark that this is not the case with Mars, the path of which planet lies outside ours. Mars, in fact, is brightest and best visible when nearest to us, and his distance has been measured, as astronomers have just measured the distance of Venus, by using the longest possible base line on the earth and determining the apparent change of place of Mars among the stars as seen from the opposite points, thus using the stars as a background. The processes, it is true, are different in their details, but the same in intention. The special observations of ingress, egress, nearest approach to sun's centre, and the like, in the case of Venus, arise out of the fact that the only available screen is a limited one and of a certain shape, and, it may be said, are so many contrivances which enable us to use the centre of the sun's disc, as we use a star in the observations of Mars. In either case, of course, whether we determine the distance between the earth and Mars or the earth and Venus, we determine the distance of the sun and the dimensions of the whole solar system.

Now, within the last few years it has been established that the sun, with its sensibly circular boundary which we see every day—the screen which we use in the case of transits of Venus—is by no means the whole of the sun; it is only the central brighter portion of it. An exterior nebulous mass, feebly luminous compared with the central one, lies outside it, and in consequence of its feeble light it is quite invisible to us, except during total eclipses of the sun, when the moon cuts off the brighter light of the central portion, and allows us to see the exterior, irregularly-bounded one, extending for hundreds of thousands of miles away into space in all directions.

Although, as we have said, this exterior portion cannot be seen, except during eclipses, in consequence of the strong illumination of our atmosphere near the sun's place, the lower brighter parts of it can yet be rendered visible without an eclipse by the use of a spectroscope, and it is no exaggeration to say that by the aid of this instrument a large part of the sun outside that part of it ordinarily visible can be seen as sharply and as conveniently as any part of the sun's surface can be observed by a telescope.

The method by which this is accomplished will be easily understood by anyone who will take the trouble to look at the flame of a candle, the wick of which has been almost covered with common salt, through one of those "drops," triangular in section, which form part generally of a common lustre or a chandelier. A small prism will, of course, be better still. If the "drop" or prism be held close to the eye and upright, some four or five yards from the candle, at such an angle that the flame can be seen through it, a perfect yellow image of the wick and flame will be seen. Besides this image there will be a blaze of

colour to the right and left of it, but the yellow image of the flame will be brighter than the rest.

Now, common salt is a compound of sodium with chlorine, which compound is decomposed by heat; and it is the vapour of the metal sodium set free which gives us, at the heat of the candle flame, light of one colour only, which cannot be dispersed or split up by the prism. The flame of the candle, on the other hand, gives out white light, which, being composed of light of all colours, is split up by the prism; so, while the prism has no action on the one, it has an enormous action on the other, and as a result gives us a perfect image of the flame, built up by the simple light of sodium vapour, brighter than the spectrum of the flame itself in that region. Further, the white light of the candle gives us no clear image, because in fact there are millions of images of every tint superposed; so that we get but a confused rainbow effect, due to the white light. The exquisite sodium image of the flame is due to the fact that there is no overlapping; and again, the reason that the addition of the salt to the flame, while it scarcely increases the light of the candle, gives us a spectral yellow image brighter than the background, is easily explained by the fact that in this part of the spectrum, as the coloured band is called, the sodium light is helping the yellow light of the flame, which gets no such help in other parts of the spectrum.

Now, we know as a matter of fact that the exterior regions of the sun give a spectrum similar in character to that given by the sodium vapour in the candle flame, and that the sun itself gives us a spectrum similar to that of the ordinary flame of the candle, and that it is because our air is illuminated by light of this kind stronger than the light of the external part of it that it is invisible to us.

To see, then, the external regions of the sun to which we have referred, the physicist looks at them through a prism, as in the candle experiment; in fact, he uses many prisms to spread out to the utmost the sun-light reflected to us by our intervening atmosphere, which, sunlight, as we have seen, has a spectrum similar in its nature to the spectrum of a candle flame. When he has done this he sees the images of the strange forms in these external regions, as the yellow image of the candle was seen, the light producing which was concealed by the brighter light of the flame till the prism was brought into play. Of course, he knows now exactly in what part of the spectrum the light which they give out is to be found. He knows that all round the sun there is an atmosphere of vividly bright hydrogen, the light of which is red; he therefore looks in the red part of the spectrum, and the atmospheric veil being withdrawn by the prism in the way we have stated, he is enabled to trace by the red light given out by the hydrogen exactly what the hydrogen is doing, and where it exactly is. He knows that magnesium is sometimes ejected from the sun with terrific force into this sea of hydrogen, and he knows that the light of magnesium vapour is green, so he examines the green part of the spectrum and so observes the exact size and shape of these volcanic bursts of magnesium vapour.

We then come to the point of this long digression. When we bring the spectroscope into play the sun is made larger; outside the round disc there is discovered a continuous envelope extending to various heights, which we can observe. Our screen, therefore, is increased, and exterior contacts are exterior contacts no longer, if we can manage to see Venus passing over the newly-discovered region before she reaches the disc.

How, then, can this be accomplished? There are three ways in which this can be accomplished. We have first that ordinarily employed in observations of the chromosphere—as the newly-discovered region which surrounds the sun and can be spectroscopically observed without an eclipse is called. We have next a method devised by

Father Secchi ; and still a third, independently hit on by several investigators.

In the method ordinarily employed, in order to avoid as much as possible the overlapping of images of sensible breadth (which prevented the white light of the candle flame from giving us even a distant approach to a pure spectrum), the light is allowed to fall on the prism through a very fine slit of a certain height. On this slit an image of the sun is thrown by a fine telescope. If the whole length of the slit is immersed, so to speak, in this image, we shall see nothing but the spectrum of the part of the disc which falls on the slit. If it is only half immersed in it, we shall see less of the spectrum of the disc, but we shall see also the spectrum of the chromosphere, as the obliterating effect of the reflection of the sunlight by our air has been destroyed by the prisms.

This spectrum will consist of bright lines, and if we can manage to place the slit on the precise spot occupied by Venus the lines will be broken, as the chromosphere will be eclipsed in this part by the planet ; and we can follow the planet's motion until the break in the line travels down to the spectrum of the sun ; this will mark the instant of exterior contact at ingress. At egress the problem is simpler, as the actual place occupied by the planet prior to external contact can be seen by an observer set to watch the sun's image on the slit of the spectroscope.

An obvious objection to this method, if a better one can be found, lies in the fact that Venus has, as it were, to be "fished for" prior to external contact at ingress, and that the slightest error in following the planet's motion would render the mode of observation useless.

The next method is one devised by Father Secchi. Using a spectroscope as before, instead of throwing a simple image on the slit, by an object-glass merely, he throws a spectrum of the sun on the slit by means of prisms, placed either before the object-glass or between it and the slit. He states that by this method the solar disc is seen with its spots and edge quite clearly defined, and that the spectral lines of the chromosphere are also seen. Further, the slit can be opened wider with advantage than under the first method. It is clear, therefore, that when Secchi's method is employed, if it does all that he says it does, observations of exterior contact would be easy.

The third method is a photographic one, and if it succeeds at all would do away with the main objection to the first two. A reference to the candle experiment will make it quite clear. If we imagine for a moment the white light of the ordinary flame of the candle to be abolished, it is clear that we should see nothing but the pure yellow image due to the monochromatic vapour of sodium. Similarly, if we imagine the light of the sun abolished, we should see the whole ring of the chromosphere if we looked at it through a simple prism, as a ring, or as a series of rings, according to the kinds of light given out by the vapour of which it is composed (the rings taking the place of the lines when we use a slit). In this way the chromosphere and the coronal atmosphere which lies outside it were actually seen in their true ring-like form by Prof. Respighi and Mr. Lockyer in the Indian eclipse of 1871, the light of the sun being temporarily abolished by the interposition of the moon.

In the third method, then, instead of a slit, a disc is used. All the sun is thus hidden, with the exception of a very small ring at the extreme edge, underlying the chromosphere. It is certain that the whole ring of chromosphere can thus be photographed every day the sun shines, as it is now observed on every such day by Mr. Seabroke at the Temple Observatory at Rugby School ; and it is believed that the lower surface of the chromosphere can be thus photographed as *hard* as the outline of the sun itself, for there are many favouring conditions which, however, it would take us too long to enter upon in this place.

It is clear that by the application of this method there is a possibility of obtaining a whole series of photographs both before and after Venus is seen on the sun, and it is also clear that the method can only be tested on the occasion of a transit.

We know that Lord Lindsay's expedition, which has been organised with a completeness which puts our official programme into the shade, is to test Secchi's method, and that Dr. Janssen was to use some spectroscopic combination. The Italian parties, as we have already mentioned, were to limit themselves to external contacts as observed by the spectroscope, but their Government subsidy came so late that it is certain they were not equipped in the most complete manner, and it is probable that their original programme has been considerably curtailed.

Although the spectroscope forms no part of the equipment of the English parties, as it certainly should have done, seeing that they intended to observe contacts more than anything else, we may still hope that some of the methods will have been tested, and that the value of the aid they bring to observations of external contact may be determined.

## NOTES

THE Belgian Academy of Sciences have conferred upon Prof. Huxley, Sec. R. S., the dignity of Foreign Associate. Such a step on the part of so very Catholic a body may make amends for the anathemas of the Irish prelates.

WE are glad to be able to contradict a statement which has appeared in some of the papers that Prof. Bunsen was about to leave Heidelberg. He has, we learn, no intention of doing so. The loss of Professors Kirchhoff and Königsberger is one which this University will feel most severely, and we cannot help wondering what the authorities at Carlsruhe were about to render it possible for two such men to be tempted away. Prof. Kirchhoff has declined the directorship of the Solar Observatory at Potsdam, and goes to Berlin as free Academician and as Professor in the University ; Prof. Königsberger has accepted the post of Professor at the large Polytechnic School in Dresden.

THE scientific results to be obtained from Arctic exploration will be carefully attended to in making the arrangements for the forthcoming Arctic expedition. Each officer will take up a special branch of scientific investigation, and will devote himself, during the interval between his appointment and the sailing of the expedition, to acquiring such knowledge as will enable him to exert his energies most usefully. There will also be a civilian naturalist or geologist in each ship, who will be carefully selected with reference to special knowledge and other qualifications. It is possible also that an Engineer officer may accompany the expedition, with charge of magnetic and pendulum observations. Some of the men forming the ships' companies will also be selected for their special qualifications. Among these, a dog-driver, named Karl Petersen, formerly cooper at the Danish settlement of Upernavik, has already been entered. There will also be three ice quarter-masters in each ship, chosen from the crews of the whalers, and one of the first duties of Capt. Markham on his arrival in England will be to proceed to Dundee for the purpose of selecting and entering these men. Capt. Markham was telegraphed for to Lisbon on the 20th, and is expected to arrive in London this week.

LIEUT. BELLOT, brother of the unfortunate Bellet, the Arctic explorer, to whom we alluded in a recent number, has obtained leave from the French Government to volunteer for the English Arctic Expedition.

ON Dec. 11, at 4.45 A.M., a severe shock of earthquake was felt by Gen. Wansouty and two friends, who intended to spend



the whole of the winter on the top of the Pic du Midi, one of the highest summits of the Pyrenees. It is curious to notice that at the same moment, Dec. 10, 10.30 P.M., a similar shock was felt in America, round Winchester, on the Washington heights, alongside the banks of the Hudson. Are these two commotions related to each other?

THE weather has lately been so dreadfully boisterous in the Pyrenees ranges that the Meteorological Observatory situated near the crest of one of the peaks has been almost demolished, Gen. Wansouty and his two friends being obliged to leave the place on the 18th at daybreak. They managed to reach on the same day at midnight, after sixteen hours travelling in the snow, a small inn at Grip, where they received every attention and were quite safe.

THE advices from the south are unanimous in stating that unprecedented masses of snow have fallen, not only in the Pyrenees and the Alps, but also in Spain, where they have put a stop to the warlike operations. On Thursday, Dec. 24, a thaw occurred in Paris, as well as in London and many other places, with an unprecedented rapidity.

THE number of railway accidents which befell English travellers on Christmas-eve has created quite a sensation in France. It is worthy of notice that in that country there is a regular staff of accomplished engineers, duly qualified by previous instruction, and paid by the Government to inspect the several lines and ascertain whether all proper measures for security have been taken by the companies. Nothing is left to haphazard, but everything is subject to a close and severe examination. The consequence is, that although the traffic on certain French lines is not less than on some of the main English ones, the accidents are less frequent and not attended with such disastrous results.

In reference to the fact that German plants were found in French soil after the German invasion, we may state that a similar phenomenon has been observed before. *Lepidium draba* was introduced into England by the English troops who failed in the attempt to land on Walcheren in 1809. The gain from the herb was probably greater than the loss from the war. In 1814 many plants from the Don became acclimatised in the Rhone valley and vicinity of Paris. The most notable improvement on record of any spontaneous flora is perhaps the addition to the Alsatian grasses by the introduction of Algerian species. These plants, although coming from a warm climate, have secured a firm footing in their new home, and rendered fertile a number of places which had remained up to that time barren and fruitless.

ON Dec. 23, the French Geographical Society, under the presidency of Admiral La Roncière le Nourry, held its annual dinner. Toasts were drunk with enthusiasm to the union of nations by science, and to the crew and officers of the *Challenger*.

AT the last meeting of the Paris Academy of Sciences, M. de Lesseps announced the capture of a female shark in the Suez Canal, containing in its abdomen (?) twelve young sharks, all living, and varying in length from twenty to twelve centimetres. This fact, adds M. de Lesseps, tends to show that the shark is truly viviparous.

A FEW days ago the French Government received from Belgium four hundred carrier pigeons presented by a columbophile of that country. These animals will be sent to the acclimatisation gardens, where a central dove-house is to be erected for the Ministry of War.

IN the printed book department of the British Museum, constant complaints have been made for years by the *employés* regarding the injurious effect of the atmosphere on their health. Quite recently Mr. Warren, head of the transcribing department, has

died, apparently from no other cause than the poisonous effect of the foul air he was compelled to breathe for many hours every day. His frequent complaints were listened to with apathy by his superiors, and notwithstanding the medical testimony by which he was backed, no attempt was made to remedy the evil. Mr. Warren's is a very hard case. He was only thirty-eight years of age, and leaves a widow and two young children, besides others who were dependent on him for the means of life. He had been in the Museum for twenty years, was a most efficient *employé*, and a general favourite. We hope the attempt which is being made to get a pension for his widow from the Civil List will be successful. He, however, has not been the only sufferer. The young men in his room are all more or less affected, some of them being under medical care. We certainly think that an investigation ought to be made into the justice of the frequent complaints as to the bad ventilation of many parts of the Museum, not even excepting the spacious reading-room. It is even said that had it not been for this cause, the accomplished Emanuel Deutsch might yet have been among us. Indeed, it is hinted that the entire management of the printed book department requires looking into; the public money being by no means spent there to the best advantage.

A VERY interesting letter appears in Monday's *Times* from a correspondent on board the *Challenger*, describing the voyage from Cape York to Hong Kong. Details are given of visits to several islands in the Malay Archipelago, in which collections of animals and plants were made. The results so far are said to be very satisfactory, and the *Challenger* has arrived in port with every store bottle and case in the ship filled up. With regard to the temperature of these eastern seas visited by the *Challenger*, the *Times* correspondent says:—"They are, in fact, a chain of sunken lakes or basins, each surrounded and cut off from the neighbouring waters by a shallower rim or border. The water, down to a depth equal to that on the border, is able to circulate freely, and gradually cools as we descend; but the whole mass below, having no means of communicating with the outer waters, remains at the same temperature as that of the water flowing over the floor of the rim; or, in other words, the icy-cold water travelling north along the floor of the ocean from the Antarctic Seas, which is found in all the deep open channels, cannot obtain admission through or over the surrounding rim. Thus, we can now affirm with certainty that the sea immediately east of Torres Straits, although having a depth of 2,450 fathoms, is surrounded by an elevated rim, having no deeper water over any part of it than 1,300 fathoms, all the water below that depth being at a steady temperature of 35°. The Banda Sea, which is 2,800 fathoms deep, is cut off at a depth of 900 fathoms; the Celebes Sea, which is 2,600 fathoms deep, is cut off at a depth of 700 fathoms; the Sulu Sea, which is 2,550 fathoms deep, is cut off at a depth of only 400 fathoms, all the water below that depth being at a temperature of 50°. On the other hand, we find that the Molucca passage is open to at least the depth of 1,200 fathoms, and the China Sea to 1,050 fathoms, the greatest depth yet obtained in them."

THE following is a list of the Council elected at the recent anniversary meeting of the Institution of Civil Engineers:—President, Thomas Elliot Harrison. Vice-presidents—William Henry Barlow, F.R.S., John Frederick Bateman, F.R.S., George Willoughby Hemans, and George Robert Stephenson. Members—James Abernethy, Sir William George Armstrong, C.B., F.R.S., Sir Joseph William Bazalgette, C.B., George Berkley, Frederick Joseph Bramwell, F.R.S., George Barclay Bruce, James Brunles, Sir John Coode, William Pole, F.R.S., Charles William Siemens, D.C.L., F.R.S., Sir Joseph Whitworth, Bart, F.R.S., and Edward Woods. Associates—Major J. M. Bateman-Champain, R.E., John Head, and Col. Charles Pasley, R.E.



FROM the Indian papers it appears that the expedition despatched from British Burmah to Yunan was to travel, not by any new route, but by the one which Major Sladen followed some six years ago. It was to start, in fact, from his point of departure, Bhamo, proceeding thence to Momein and Taliifa. From the last-named city, once more subject to a Chinese governor, it will sail down the mighty Yangtse, with Shanghai for its final goal. The exploring party is commanded by Col. Horace Browne, one of the most distinguished officers of the Burmah Commission. Mr. Ney Elias is a member of the expedition, and Dr. John Anderson, who goes as scientific officer, with a small staff of Eurasian and native collectors, is already well known as a member of the former expedition to Bhamo and Yunan. If the present party succeed in reaching Shanghai, they will be the first Europeans who, at least since the days of Marco Polo, have ever made their way through China from the West.

It is with somewhat mingled feelings that we have perused the Report of the "Botanical Locality Record Club" for 1873. Any addition to our knowledge of the geographical distribution of British plants is very valuable, and the Recorder and his correspondents have industriously compiled much useful and interesting observation. But what chance remains of the permanence of our rarer plants when their localities are published in this way? We are glad to find that one of the rarest and most interesting of British plants, the Lady's Slipper, *Cypripedium Calceolus*, has been found in several other localities in the woody magnesian-limestone denes of Durham, besides the original one of Castle Eden; the exact spots are wisely withheld.

MR. R. ROUTLEDGE, B.Sc., F.C.S., has been appointed to the Professorship of Natural Philosophy at the Bedford College, York Place. Lecture rooms and a chemical laboratory fitted with the requisite appliances for the practical teaching of physical science are in course of preparation; but pending the completion of these, arrangements have been made to commence the next session with an elementary course of experimental lectures on heat, in another apartment of the College.

SURGEON-MAJOR DAY, F.Z.S., Inspector of Fisheries in India, has recently issued a second report on the fisheries of India and Burmah, which treats of the sea fisheries of those countries, and of the principal customs affecting the supply of fish. The case of the fisheries in the East is entirely different from that in this country. In India, the chief subject of investigation is how to augment the working of the sea fisheries; in Great Britain, one of the main objects of the Legislature in the various inquiries that have been made has been to see if they were being overworked, and to devise means for their preservation and protection. Although certain customs exist which, if observed on a large scale, would seriously affect the fisheries of India, still the general facts seem to prove that there are not sufficient means for properly capturing and utilising the natural supplies of fish. One of the principal defects is the want of quick means of carriage of the fish to the inland towns; to secure a supply of fish in the interior, it is necessary to salt them, and a great impediment to the trade in salt fish is the Government tax on salt. On this point Dr. Day's remarks are very important. He says: "It may be well to decide whether it is humane or even prudent, in a sanitary point of view, to make the price of salt so excessively high that it cannot be used to preserve fish with, and thus compel the people to go without or consume it putrid or rotten. We read that in Bergen there are two large hospitals devoted exclusively to the treatment of patients suffering from a peculiar form of disease brought on by eating badly-cured fish; the disease is a mixture of leprosy and elephantiasis" (both common in Orissa). In Ireland, in 1645, we are told that the leprosy was driven out of Munster by the

English, the disease being due to the people eating foul salmon or those out of season. This was prohibited, and the prohibition enforced 'whereby hindering these barbarians against their will to feed on that poisonous meat; they were the cause of that woeful sickness which used so mightily to reign among them, but hath in time been almost abolished.' The collector of Ratnagiri states that the high duty on salt is undoubtedly a source of epidemics and other serious illnesses induced by eating imperfectly prepared fish. I think the foregoing extract sufficient to show that compelling a population to eat rotten fish may be a rather impolitic act."

THE Council of the Society for the Promotion of Scientific Industry, the head-quarters of which are at Manchester, has decided to give gold, silver, and bronze medals for excellence and novelty in the various classes of exhibits at the exhibition of implements, machines, and appliances for the economising of labour, which is to take place in Manchester in 1875. The arrangements for the Exhibition are progressing satisfactorily, and space has been secured by many high-class engineering and other firms.

THE tenth number of the third volume of the Bulletin of the Museum of Comparative Zoology consists of an article on the *Ophiuride* and *Astrophytidae*, old and new, by Theodore Lyman, in continuation and rectification of previous memoirs on the same subject. Many new species are indicated, principally from the Philippine Islands, where they were collected by Dr. Semper, from whom they passed into the possession of the Museum of Comparative Zoology. The memoir is illustrated by seven plates, showing the anatomy of the *Ophiuride*, the growth of spines, hooks, and stumps, the formation of armed spines, &c., and the characters of the new species.

THE additions to the Zoological Society's Gardens during the past week include two Hardwicke's Mastigures (*Uromastix hardwickii*) from India, presented by Lieut.-Col. C. S. Sturt; a Nicobar Pigeon (*Caloenas nicobarica*) from the Nicobar Islands, presented by Capt. R. J. Wimberley; two Bonnet Monkeys (*Macacus radiatus*) from India, presented by Mr. L. Miller and Miss J. Watt; two Mazame Deer (*Cervus campestris*) from South America, purchased; a Paradise Whydah Bird (*Vidua paradisica*), a Pin-tailed Whydah Bird (*Vidua principalis*) from West Africa, received in exchange.

## THE PRESENT CONDITION OF THE ROYAL SOCIETY

(Extracted from the President's Address at the Anniversary Meeting.)

IT has been represented to me that, the Royal Society being now, after eighteen years of temporary accommodation, settled in quarters of which we hope to retain undisturbed occupation for some generations to come, an account of the present position of the Society in respect of our more important possessions, foundations, and functions, and our relations to the Government, would not only be generally acceptable, but might even be required of me by that large and increasing class of Fellows who live far from our doors. This class now numbers as nearly as possible one half of the Society, few of whom can be even occasional attendants at our meetings; and if to this class of absentees be added the large number of residents within the metropolitan district whose avocations prevent their attending, it will not surprise you to hear that (as I have ascertained by careful inquiry) a very large proportion of our fellow members know little of the Society's proceedings beyond what appears in our periodical publications, nor of our collections, nor of the tenure under which we occupy our apartments under the Crown—and that many have never heard of the funds we administer, whether our own or those voted by Parliament in aid of scientific research, nor of the fund for relief of the necessitous, nor of the gratuitous services rendered by the Society to various departments of the Government.

Unlike the great Academies of the Continent, the Royal Society has never published an almanack or annuaire containing information upon its privileges, duties, constitution, and management. Particulars on these points are for the most part now accessible to the Fellows only by direct inquiry, or through the Council Minutes; and these, and non-resident Fellows, are practically inaccessible. In my own case, though I have long been a resident Fellow and had the honour of serving on your Councils for not a few years, it was not until I was placed in the position I now hold that I became aware of the number and magnitude of the Society's duties, or of the responsibility these impose on your officers.

It is upwards of a quarter of a century since an account of the foundations that then existed and the work the Society then carried on was published in Weld's valuable but too diffuse "History of the Royal Society." These have all been greatly modified or extended since that period; and many others have been added to them; so that the time has now arrived when a statement of the large funds applicable to scientific research which the Society distributes, the conditions under which these are to be applied for, and other particulars, might with advantage be published in a summary form and distributed to the Fellows annually.

*Finance.*—After the financial statement made by the auditors, you will, I am sure, conclude that there is no cause for apprehension in respect of the Society's funds or income; and when to this I add that the expenses of removal from the old house, including new furniture, amount to 1,300*l.*, and that the volume of Transactions for the present year will contain eighty-six plates, the largest number hitherto executed at the Society's cost within the same period, you will also conclude that there is no want of means for providing illustrations to papers communicated to us for publication.

The landed property of the Society, as stated in the printed balance-sheet now before you, consists of an estate at Acton, in the neighbourhood of London, and an estate at Mablethorpe, Lincolnshire, each yielding a good rental. The Acton estate, at present on lease to an agricultural tenant, is planned to be let as building land, for which it is favourably situated, and will thus become increasingly valuable.

The subject of the tenure under which the Society holds the apartments we now occupy was brought up on a question of insurance. That question has been satisfactorily settled by reference to the Treasury; but it may still be worth while briefly to state the facts which the Council considered as furnishing valid grounds for appealing against the requirement to insure, and for at the same time requesting an assurance that the permanence of our tenure is in no way weakened by our removal to this building. These are: that when the apartments in Somerset House were originally assigned to the Society by command of George III., they were granted "during the pleasure of the Crown, without payment of rent or any other pecuniary consideration whatever;" that the Society was not required to insure either in Somerset House or old Burlington House; that when the Society removed at the request of the Government from Somerset House and accepted temporary accommodation in Burlington House, it was under the written assurance of the Secretary of the Treasury, addressed to the President of the Society, that the claims of the Society to "permanent accommodation should not be thereby in any respect weakened;" that in the debates on the estimates in 1857, the Secretary of the Treasury stated, in his place in Parliament, that "the Society could not be turned out of Somerset House without its own consent," and that "it was entitled to rooms by royal grant."

To this appeal the Lords Commissioners returned a satisfactory answer; and their letter, dated October 27th last, assures us "that there is no intention on the part of the Treasury to alter the terms on which the Royal Society holds its appointments under the Crown; the conditions of the Society's tenure will therefore be the same as those on which it occupied rooms in Somerset House, and was subsequently transferred to Burlington House."

While feeling it my duty to lay these details before you, I must accompany them with the assurance that nothing has occurred during this correspondence to disturb the unbroken harmony that has existed between her Majesty's Government and the Royal Society, ever since our occupation of apartments under favour of the Crown.

On every occasion of change of quarters the Society has

received abundant proofs of the regard shown by the Government for its position, requirements, and continued prosperity; and there is, I am sure, every disposition on the part of the Government to recognise the fact that the privileges conferred on the Society are fully reciprocated by the multifarious aid and advice furnished by your Council in matters of the greatest importance to the well-being of the State.

The practice of electing Fellows of the so-called privileged class whose qualifications were limited to accident of lineage or political status, has been viewed with grave dissatisfaction by many, ever since the election of ordinary Fellows was limited to fifteen. The Council has in consequence felt it to be its duty to give most careful attention to the subject, which it referred to a committee, whose report has been adopted and embodied in a by-law.

The privileged class consisted, as you are aware, of certain royal personages, peers of the realm, and Privy Counsellors (Statutes, Sect. iv. cap. 1); and they were balloted for at any meeting of the Society, after a week's notice on the part of any Fellow, without a suspended certificate, or other form whatever.

The committee reported that it was desirable to retain the power of electing, as a "privileged class," persons who, while precluded by public duties or otherwise from meeting the scientific requirements customary in the case of ordinary Fellows, possessed the power and had shown the wish to forward the ends of the Society, and recommended that the class should be limited to the princes of the blood royal and members of her Majesty's Privy Council. And with regard to the method of election, they recommended that a prince of the blood royal might be publicly proposed at any ordinary meeting, and balloted for at the next; that, with regard to a member of her Majesty's Privy Council, he might be proposed at any ordinary meeting by means of a certificate prepared in accordance with chap. i. Sect. iii. of the Statutes, membership of the Privy Council being the only qualification stated—the certificate being, with the Society's permission, suspended in the meeting-room till the day of election, which should fall on the third ordinary meeting after suspension.

Having regard to the eminent services to the State which have been rendered by Privy Counsellors, and to the fact that all peers who do render such services are habitually enrolled on the list of Privy Counsellors, it was believed by the Council that the effect of thus limiting the privileged class would be that the doors of the Society would remain open to all such peers as desire and deserve admission, but who have not the ordinary qualifications for fellowship; while all such peers as might appear with claims which compete with those of ordinary candidates would prefer owing the fellowship to their qualifications rather than to their birth.

The Council hopes that by this means the so-called privileged class will be reinforced, and that statesmen who may have considered themselves ineligible through want of purely scientific qualifications, or who have hesitated to offer themselves from the fear of interfering with the scientific claims of others, will in future come forward and recruit our ranks.

A passing notice of the manner of proposing candidates for the ordinary class of fellowship may not be out of place. Theoretically this is done by a Fellow who is supposed to be a friend of the candidate, is versed in the science on which his claims are founded, and is satisfied of his fitness in all respects for fellowship. It is most desirable that the Fellow who proposes a candidate should take upon himself the whole duty and responsibility of preparing the certificate, should sign it first, and himself procure the signatures of other Fellows in whose judgment of the candidate's qualifications the Council and the Society may place implicit confidence. It is unsatisfactory to see attached to a candidate's certificate an ill-considered list of signatures, whether given from personal or from general knowledge; and the happily rare practice of soliciting signatures and support, directly or indirectly, by the candidate himself, cannot be too strongly deprecated. For obvious reasons the president, officers, and other members of the Council have hitherto during their periods of office abstained from proposing a candidate of the ordinary class, or from signing his certificate, but have not withdrawn their signatures from certificates sent in before they took office. The Council and officers will probably not feel the same objection to signing the certificates of candidates of the privileged class, as these will not be selected for ballot by the Council, but will be elected by the Society at large at their ordinary meetings.

In carrying on the business of the Society the Council is much indebted to committees appointed annually for special purposes, or to whom an occasional question is referred. The annual appointments include the Government Grant, the Library, the Soirée, and the Acton Estate committees. The temporary committees of the past year have been the Circumnavigation, the Transit of Venus Expeditions, the Arctic, the House, the Brixham Cave, the Privileged Classes, and the Davy Medal committees. Besides these there are two permanent committees, the Meteorological and the Scientific Relief, to which fresh members are appointed as vacancies occur. From these designations, it will be understood that some of the committees have been occupied with questions connected with the Government service, while others have devoted themselves exclusively to the business of the Society.

I shall now mention such of the labours of these committees as seem to be most worthy of your attention.

The *Meteorological Committee of the Board of Trade*, as it ought to be called, discharges in all respects the most arduous and responsible duties of any, controlling as it does the whole machinery of the British Government for the making, registering, and publishing of especially oceanic meteorological phenomena throughout the globe.

The primary purpose for which this and all similar offices were established was the acceleration of ocean passages for vessels by an accurate investigation of the prevalent winds and currents. In other words, their great object is to aid the seaman in what Capt. Basil Hall called "one of the chief points of his duty"—namely, "to know when to find a fair wind, and when to fall in with a favourable current." The first impulse to the formation of an office for this purpose was given by the late General Sir J. Burgoyne, who in 1852 started the idea of land observations to be carried out by the corps of Royal Engineers.

Shortly afterwards our Government corresponded with the United States Government on the subject of co-operating in a scheme for land observations, which was followed by a suggestion on the part of America that the operations should be extended to the sea.

The correspondence was referred to the Royal Society, which warmly approved the scheme of sea observations, but saw many difficulties in carrying out that for the land. The Brussels Conference followed in 1853, when representatives of most of the maritime nations assembled and adopted a uniform plan of action. Soon after this, Lord Cardwell, then President of the Board of Trade, established the Meteorological Department of that office, and placed the late Admiral Fitzroy at the head of it—the Royal Society, at the request of the Government, supplying copious and complete instructions for his guidance, which were drawn up mainly by Sir Edward Sabine. Admiral Fitzroy's zeal and his great labours are known to all; he worked out the system of verifying and lending instruments, planning surveys, registering observations, publishing results; and, lastly, himself originated the plan of predicting the weather, and establishing storm-signals at the sea-ports along the coast.

On Admiral Fitzroy's death in 1865 the Royal Society was again consulted as to the position and prospects of the office. Its report, which did not differ materially from that of 1855, was in 1866 referred to a committee, composed of a representative of the Board of Trade, of the Admiralty, and of the Royal Society. This committee supported the previously expressed views of the Society, and suggested the placing of the office under efficient scientific superintendence; upon which the Society, in the same year, was requested by the Government to undertake the superintendence of what had been the Meteorological Department of the Board of Trade. To this request the Council of the Society so far acceded as to nominate a committee of eight Fellows (subsequently increased to ten) to undertake the entire and absolute control of the office; and a parliamentary grant of 10,000*l.* per annum was provided to maintain it.

This is in brief a history of the connection between the Royal Society and the Meteorological Office on the one hand, and between the office and the Government on the other. It is a very anomalous position, and has been greatly misunderstood. It has led to the misconception on the part of some that the Society controlled the office, and by others that the Government (Board of Trade) controlled it, and by more that the annual grant of 10,000*l.* is made to and in support of the Royal Society, or of its own objects, whereas the grant is paid direct to the director of the office as soon as voted. The Society's action is confined to the selection of the committee, which superintends the office, while the Board of Trade, leaving to the committee the details

of their operations, exercise only a general control. The labours of the committee are entirely gratuitous, and no part of the 10,000*l.* is touched by them or by the Royal Society.

I believe there is no parallel to such an organisation as this in any other department of the Government. It has its advantage in securing to the office absolute freedom from that disturbing element in the public offices, that their heads are chosen partly on political grounds and change with every Government, and its disadvantage in wanting the support of direct Government authority and prestige. Hitherto, owing to the care of the committee, which meets almost weekly, to the zeal and efficiency of the director (who is also secretary to the committee) and of the Marine Superintendent, it has worked well. Into its working it is not my purpose to enter; its efficiency and value are fully acknowledged by the public. No more practical proof of this can be cited than the general desire, supported by memorials presented to Parliament, for the restitution of the storm-signals, which were discontinued after Admiral Fitzroy's decease, on the ground of their trustworthiness having been called in question. It is no little testimony to the foresight of that zealous officer that they are not only now re-established and in full working order at 100 stations on the coast of Great Britain, but that the very warnings issued from Paris to the coast of France by the Government of that country are actually sent to Paris from the Meteorological Office in London. The same warnings are transmitted along the whole European coast, from Norway to Spain; and the system has been extended to Italy, Portugal, and Australia.

The New Observatory, which is used also as the central observatory of the Meteorological Committee, is supported by a grant from that committee, and by the munificence of our Fellow, Mr. Gassiot, who has settled on it a fund which produces 500*l.* a year for the carrying on of observations chiefly magnetical.

The *Circumnavigation Committee*.—The scientific results of the *Challenger* Expedition have far exceeded our most sanguine anticipations. The Temperature Survey of the Atlantic may, as Dr. Carpenter informs me, be truly characterised as the most important single contribution ever made to Terrestrial Physics, presenting as it does the whole thermal stratification of an oceanic area of about 15 million square miles and with an average depth of 15,000 feet. Nor are the results of the Pacific Survey less important. Some of these were laid before you at our meeting of the 26th inst. in Prof. Wyville Thomson's "Preliminary Notes on the Nature of the Sea-Bottom in the South Sea," which reveal the existence of hitherto unsuspected processes of aqueous metamorphism at great depths in the ocean, and throw an entirely new light upon the geological problem of the origin of "azoic" clays and schists.

Valuable papers on new and little known marine animals have been contributed to our Transactions and Proceedings by Mr. Willemoes-Suhm, Mr. Moseley, and other members of the civilian scientific staff of the *Challenger*; and a number of the Journal of the Linnean Society is devoted to the botanical observations and collections made by Mr. Moseley during the course of the voyage.

*Transit-of-Venus Committee*.—Upon the representation of your Council, her Majesty's Government has attached naturalists to two of the astronomical expeditions sent out from this country to observe the Transit of Venus. The stations selected were the two most inaccessible to ordinary cruisers, and at the same time most interesting in regard to their natural productions—namely, the island of Rodriguez in the Mauritius group, and Kerguelen's Land in the South Indian Ocean.

The objects and importance of these appointments were laid before the Government in the following statement:—

"It is an unexplained fact in the physical history of our globe that all known oceanic archipelagos distant from the great continents, with the sole exception of the Seychelles and of a solitary islet of the Mascarene group (which islet is Rodriguez), are of volcanic origin. According to the meagre accounts hitherto published, Rodriguez consists of granite overlaid with limestone and other recent rocks, in the caves of which have been found the remains of recently extinct birds of a very singular structure. These facts, taken together with what is known of the natural history of the volcanic islets of Mauritius and Bourbon to the west of Rodriguez and of the granitic archipelago of the Seychelles to the north of it, render an investigation of its natural products a matter of exceptional scientific interest, which, if properly carried out, cannot fail to be productive of most important results.

"As regards Kerguelen's Land, this large island (100 by 50 miles) was last visited in 1840, by the Antarctic Expedition under Sir James Ross, in mid-winter only, when it was found to contain a scanty flora of flowering plants, some of which belong to entirely new types, and an extraordinary profusion of marine animals and plants of the greatest interest, many of them being representatives of north-temperate and Arctic forms of life.

"H. M.S. *Challenger* will no doubt visit Kerguelen's Land, and collect largely; but it is evident that many years would be required to obtain even a fair representation of its marine products; and though we are not prepared to say that the scientific objects to be obtained by a naturalist's visit to Kerguelen's Land are of equal importance to those which Rodriguez will yield, we cannot but regard it as in every respect most desirable that the rare opportunity of sending a collector to Kerguelen's Land should not be lost."

I may further state as a matter of great scientific interest, that Rodriguez contains the remains of a gigantic species of land-tortoise allied to those still surviving in some other islands of the Mauritius group, and that the nearest allies of these are the gigantic tortoises of the Galapagos Islands in the opposite hemisphere of the globe, as one of our Fellows, Dr. Günther, has shown in a paper read last session to the Society. Very valuable collections of these fossils have been made by Mr. Newton, the Colonial Secretary of Mauritius, during a brief stay which he was enabled to make in Rodriguez; but the materials are far from sufficient for obtaining all the information we want.

In accordance with your Council's recommendation, the Treasury sanctioned the appointment of four naturalists—three to Rodriguez, and one to Kerguelen's Land. Those sent out to Rodriguez are:—Mr. I. B. Balfour, son of Prof. Balfour, of Edinburgh, F.R.S., who, besides being educated as a botanist, has worked as a field geologist in the Geological Survey of Scotland; he is charged with the duties of botanist and geologist; Mr. George Gulliver, son of one of our Fellows and a pupil of Prof. Rolleston, in Oxford, who goes out as naturalist; and Mr. H. H. Sleser, who has had great experience as a cave explorer, and who will devote his attention especially to the collection of fossils.

The Kerguelen's Land duties are undertaken by the Rev. A. E. Eaton, M.A., a gentleman most favourably known as an entomologist, and who had made very important collections in Spitzbergen, which he visited for the purpose of studying its fauna and flora. These gentlemen had, by the last accounts, all proceeded to their destinations.

(To be continued.)

#### FRENCH ACADEMY OF SCIENCES.—ANNIVERSARY MEETING

THIS Anniversary took place on the 28th December, the president being M. Faye, who delivered an able address, giving some interesting details as to the history of the prizes offered for competition by the Academy.

One of the first ever offered was a sum of 4,000*l.* given by Philippe d'Orleans, then Regent of France, in 1716, to be awarded to the person or persons who should invent a method of determining longitude at sea. This handsome sum was not awarded to anyone up to 1793, when the Academy was suppressed, M. de Choiseul, French Ambassador to England, having made fruitless exertions on behalf of Harrison, the well-known chronometer maker, in 1763.

A circumstance connected with these old prizes is worth noting. La Condaminé, about 100 years ago, offered a prize for an essay on the question "why so many differences of colour were noted between the male and female livery in quadrupeds as well as in birds." The question being deemed useless, the money was not accepted by the Academy.

In the last century almost all the prizes were won by Euler and Bernoulli, but now scarcely any of the prizes, amounting to 160*l.*, are awarded; sometimes nobody competes for them.

Although the distribution this year is both for 1872 and 1873, only two of the competitive prizes have been taken, one for 1873 by M. Mascart, professor in the Collège de France, for a paper on the modification which the light of the sun undergoes in consequence of the motion either of the sun or of the earth. M. Mascart failed to observe any modification, but the prize was given to him owing to the care and ingenuity displayed in his experiments. One prize was also won by M. Balbrain for a

paper on the reproduction of animals that present parthenogenetic phenomena.

The proceeds of the 4,000*l.* offered by M. Breaud to the person who should discover a cure for the cholera was divided between several partly successful essayists for 1872 and 1873, but it is not likely that the sum itself will ever be parted with by the Academy.

The prizes offered for general excellence or voluntary work on a certain subject have been a great deal more fortunate, so that the method adopted by the Royal Society promises better results than the old academical competitive system, even in Paris. The Piumy prize of 120*l.* for the best paper on the improvement of steam navigation was gained for 1872 by M. Zaurines, who has carefully investigated propulsion by the Archimedean screw; in 1873 by M. Bertin, for a paper on the best method of ventilating steamers.

The Lalande prize in astronomy has been gained for 1872 by the brothers Henry for the discovery of a number of small planets at the Paris Observatory, and in 1873 by M. Coggia, of the Observatory of Marsilles, for his discoveries among comets.

The Poncelet prize has been given for 1872 to M. Mannheim for the general excellence of his geometrical disquisitions, and in 1873 to Sir W. Thomson for his magnificent works on the mathematical theory of electricity and magnetism.

The Godard prize for 1872 has been awarded to Dr. Pettigrew for his work "On the Muscular Arrangements of the Bladder and Prostate, and the manner in which the Ureters and Urethra are closed."

The aggregate sum to be awarded yearly, exclusive of the Breaud prize, is 4,400*l.*, and the number of prizes nineteen, only a few being for subjects specially proposed by the Academy. The competition is open to all nations. The names of competitors must be placed in sealed envelopes, which are opened only in the case of those who succeed; but, except in the case of prizes given for general excellence, papers must be written either in Latin or in French.

#### SCIENTIFIC SERIALS

*Jahrbuch der k.k. geologischen Reichsanstalt.* Band xxiv. Nos. 1 and 2.—The first article in No. 1 is by Dr. A. Redtenbacher, and treats of the stratigraphical relations of the mesozoic formations as developed in the district of Gams, near Hiefau. The second paper, by Dr. C. Doelter, gives some account of the Siebenbürgischen metalliferous mountains. The district described lies south of the river Aranyos, between Offenbánya and Bistna, as far as the Maros. The formations developed in this district consist of (1) crystalline, metamorphic, and eruptive rocks (gneiss, crystalline limestone, granite, diorite, syenite); (2) Jurassic and cretaceous (limestone, melaphyre and augite porphyry, sandstone, chalk, &c.); (3) Tertiary (comprising, besides various fossiliferous deposits, such igneous rocks as hornblende-andesite, augite-andesite, basalt); (4) alluvium. A sketch-map accompanies Dr. Doelter's communication.—Herr K. Hömes contributes a paper entitled "Tertiary Studies," in which he gives an account of the mollusca met with in various Tertiary deposits (as at Kischeneff, Jenikale, &c.) A number of the species described are new to science. Four excellent plates illustrate the paper.—Dr. E. Mojsisovics, whose contributions to the *Jahrbuch* are both frequent and valuable, gives us a long paper on the Triassic period in the East Alps. He discusses the distribution of the Triassic fauna, and shows that the formation itself may be divided into zones, each characterised by certain well-marked species; farther, he describes at length the nature of the deposits, and points out that the trias is characterised throughout by the constant presence of poorly fossiliferous limestone and dolomite and richly fossiliferous marl and calcareous marl.—The only geological paper in No. 2 is one by Dr. Guido Stache, on the palaeozoic regions of the East Alps. The author describes in considerable detail the structure of the rock-masses forming the Alpine lands of Austria, and gives a coloured geological map of the regions described, and two plates of horizontal sections.—Amongst the mineralogical papers accompanying these numbers of the *Jahrbuch* may be noted one by Dr. Doelter, On the traclite of the Siebenbürgischen metalliferous mountains, in which a number of analyses are given.—Herr Kalkowsky furnishes an account of the microscropy of the felsite and pectstein of Saxony.—A new mineral (Ludwigite) from Banat is described by Tschernak; and a

Report of the volcanic eruptions and earthquakes that took place during last year, is given by C. W. Fuchs. The latter author furnishes a translation from the Swedish of Nauckhoff's paper On the occurrence of native iron in a basalt vein at Oviak, in Greenland, in connection with which we note also a paper by the editor (Tschermak) On the meteorite-find in Greenland.

*Astronomische Nachrichten*, No. 2015, contains a detailed statement of observations made at Washington by Cleveland Abbe on the position of Coggia's comet, together with the form of the tail, its length, and other details.—F. Tietjen gives elements of Dr. Falser's planet (139), together with an ephemeris for November and December.

*Memorie della Societa degli Spettroscopisti Italiani*.—Father Secchi sends an account of his observations on the solar eclipse of October last. He observed the contacts of the limbs of the sun and moon by the spectroscopic method, and discusses its advantages over the ordinary method with the simple telescope.—The same author sends drawings of the chromosphere from December 26, 1873, to August 2, 1874, and he remarks on the continual diminution in the frequency and height of the prominences in accordance with the diminution in number of sun-spots. The sun appears to have been seen, on an average, rather oftener than every other day.

*Annali di Chimica applicata alla Medicina*, vol. lix, No. 3, September, opens with a paper in the Pharmaceutical Section by Prof. Borsarelli, of Turin, entitled "General and Comparative Study of the Pharmacopoeias of Europe and America."—In the same section is a paper by Dr. C. Girard, On protoxalate of iron, and one by Leger, On a tartrate of magnesium lemonade.—In Hygiene there is a paper by Cunningham, On the microscopic examination of the air.—Drs. Lanz and Ferrigi communicate a paper to the Pathological Section, on palustrine miasma.

## SOCIETIES AND ACADEMIES

### LONDON

Linnean Society, Dec. 17.—Dr. Allman, president, in the chair.—The President read a paper on the Diagnosis of new Genera and Species of Hydroids. Several very interesting collections of Hydroids had recently been placed in the author's hands for determination. One of the most important of these is from the zoological museum of the University of Copenhagen, and consists entirely of gymnoblastic forms obtained from various parts of the world, but principally from the Scandinavian shores. The author is indebted for it to Prof. Lütken, of the University of Copenhagen. Another collection, consisting of calyptoblastic forms, was made in the Japan seas by Capt. St. John, of H.M.S. *Sylvia*, and sent to the author for determination by Mr. J. Gwynn Juffres, by whom it is destined for the British Museum. For another valuable collection, containing many new species, the author is indebted to Mr. Busk; while a collection, belonging chiefly to the family of Plumulariidae, was made by Mr. Holdsworth in Ceylon, and contains several curious forms; and, lastly, for a small collection from the shores of Spitzbergen, the author is indebted to the Rev. Mr. Eaton, by whom it was obtained during a recent yacht voyage to that region. Among the new species from the Copenhagen Museum, one of the most interesting is a *Hydractinia*, from Spitzbergen. It is distinguished from *H. echinata* of our own shores by its nearly smooth spines, but more especially by the peculiar condition of its gonosome, the blastostyles being destitute of the capitulum which forms so characteristic a feature in *H. echinata*, while each carries only a single spherical sporosac of comparatively enormous size. He proposes for it the name of *H. monocarpa*. The same collection contains a new *Cladocoryne*, the second species as yet discovered of this remarkable genus. It was found attached to Gulf-weed, and is especially interesting in being provided with its reproductive zooids, structures hitherto unknown in the genus. These are developed among the tentacles, and are almost without doubt medusiform, though this point could not be determined with absolute certainty. For the new species the name of *C. peltatica* was proposed. Another hydroid from the same collection was a beautiful *Amalthæa*, a genus nearly allied to *Corymorpha*. It was obtained from Iceland. One of its most striking features consists in the great length of its proximal tentacles; these are nearly as long as the entire stem round which, in the living animal, they must have hung

down in the form of a graceful inverted tassel of flexile filaments subject to the impulse of every passing current of the surrounding water. The name of *A. islandica* was proposed for it. The Japan collection contained, among other interesting species, a *Campanularia*, remarkable for the comparatively enormous size of its cups, which exceeded by about five times the dimensions of those of the largest British species. It was named *C. grandis*. This collection contained also a beautiful *Thuiaria*, for which the name of *T. coronata* was proposed, and in which the female gonangium or receptacle for the ova was crowned by about nine very long bifurcating hollow spines, which formed a cage-like chamber into which the ova subsequently passed. An extension of the cosarc is continued from the enlarged summit of the blastostyle or fleshy columnar axis of the gonangium through the whole length of the spines; and as the blastostyle must be homologically regarded as a hydranth arrested and adapted to functions connected with reproduction instead of nutrition, the author looked upon the spines as representing the tentacles of a hydranth which had lost their prehensile functions, become clothed with chitine, and adapted to the protection of the ova during an early period of their development. Mr. Busk's collection contained many beautiful new species of calyptoblastic hydroids. Among these was a *Sertularella*, whose tubular hydrotheca, free from the stem in nearly their entire length, were deeply cleft at their distal ends, in the manner of a mitre. For this curious species the name of *S. episcopus* was proposed. A new genus, under the name of *Gemmulina*, was constituted for a sertularia-like form, in which the hydrotheca, instead of being situated on the opposite sides of the stem, were all brought to the front of the stem, and there became adnate to one another in pairs. A beautiful *Thuiaria*, with a remarkable dichotomous ramification of the main stem, and with the gonangia situated in the axils of the branches, presented a striking resemblance to the inflorescence of certain common caryophyllaceous plants, and was named *T. Cerastium*. Mr. Holdsworth's collection, made on the coast of Ceylon, contains some very remarkable species. Among these is a magnificent Plumularian of the *Aglaophenia* type, rendered striking by the great length of its mesial nematophores, and by the presence of two very long divergent teeth which project from the margin of the remarkably patulous hydrotheca. The species grows in the form of crowded tufts of beautifully graceful plumes. It would seem to belong to the group which Kirchenpauer places in his sub-genus *Makrorrnychia*, and the name of *Makrorrnychia insignis* is now proposed for it; but as no gonosome has as yet been found in any of the specimens, the generic name is only provisionally assigned to it. For another beautiful form from the same collection the author has constituted a new genus under the name of *Taxella*. Its hydrotheca and nematophores are formed on the type of those of the genus *Aglaophenia*, but its gonophores are not protected by corbule, and its ramification presents the peculiarity of being doubly pinnate, so that it represents in the *Aglaophenia* section of the Plumulariidae a form which in the Plumularian section is represented by the genus *Diplopteron*, a genus recently constituted by the author for one of the deep-sea hydroids of the *Forcupine* Exploring Expedition. The name of *Taxella eximia* is assigned to the present species, which grows in dense tufts to the height of about a foot. In Mr. Eaton's collection, from Spitzbergen, the only well-preserved hydroid is a little *Sertularia* with regularly pinnate ramification, elongated hydrotheca, and a long ovate gonangium curiously constricted near its middle. The author gives it the name of *S. arctica*.

Geologists' Association, Dec. 4.—Henry Woodward, F.R.S., president, in the chair.—Dr. W. B. Carpenter, F.R.S., On the conditions which determine the presence or absence of animal life on the deep-sea bottom.

### EDINBURGH

Royal Society, Dec. 21.—Prof. Kelland, vice-president, in the chair.—The following communications were read:—Remarks on the great logarithmic table computed at the Bureau du Cadastre under the direction of M. Prony, by Mr. Edward Sang.—On the elimination of  $\alpha$ ,  $\beta$ ,  $\gamma$ , from the conditions of integrability of  $S$ ,  $U_{\alpha\beta}$ ,  $S$ ,  $U_{\beta\gamma}$ ,  $S$ ,  $U_{\gamma\alpha}$ , by M. G. Plarr. Communicated by Prof. Tait.—The development of the ova and structure of the ovary in the Mammalia, by James Foulis, M.D. Communicated by Prof. Turner.—Mathematical Notes, by Prof. Tait.—(1), On a singular theorem given by Abel; (2), On the equipotential surfaces for a straight wire; (3), On a fundamental principle in Statics.

## MANCHESTER

Literary and Philosophical Society, Dec. 1.—Rev. Wm. Gaskell, M.A., vice-president, in the chair.—Some doubts in regard to the law of the diffusion of gases, by Mr. H. H. Howorth.

Dec. 15.—Mr. Edward Shunck, F.R.S., president, in the chair.—Rev. Wm. Gaskell, M.A., read an interesting account of Horrocks' and Crabtree's observations of the Transit of Venus in 1639, published in the *Annual Register* for 1769.—Some particulars respecting the negro of the neighbourhood of the Congo, West Africa, by Mr. Watson Smith, F.C.S.—Analysis of one of the Trefriw mineral waters, by Mr. Thomas Carnelley, B.Sc. Communicated by Prof. H. E. Roscoe, F.R.S.

## GLASGOW

Geological Society, Dec. 15.—Mr. John Young, F.G.S., vice-president, in the chair.—Mr. James Neilson, jun., exhibited a selection of fossils from the Irish and Scotch limestone beds, and read a paper on the Armagh limestones, and their equivalents in Scotch strata.—Mr. James Dairon read a paper on the graptolites of the Upper Llandelo rocks of the south of Scotland. Mr. Dairon described more particularly the following forms: *Climacograpsus teretisculus*, *Ditymograpsus*, *Dicranograpsus*, and *Pleurograpsus*, pointing out the characteristic features of each, and indicating their range in the rocks of the formation, and the beds in which they severally occur most abundantly. The paper was illustrated by drawings and by a beautiful collection of specimens.

## BOSTON, U.S.

Society of Natural History, March 18.—The president in the chair.—Dr. Samuel Kneeland read a paper illustrated by diagrams and specimens, on the evidence for and against the so-called sea-serpent. He thought a careful weighing of the evidence showed that such an animal is not a zoological absurdity, and that from paleontology (if we discard the testimony of many credible witnesses) we may even conclude that it is a possibility—and, he believed, a probability—that some form, intermediate between the marine saurians of the Secondary and the elongated cetaceans of the Tertiary has come down to the present epoch, and will eventually come under the notice of naturalists, and prove, in this as in many other cases, that widely spread popular beliefs in natural history, especially when professing to rest upon credible testimony, have generally for their foundation some portion of scientific truth. He believed there were at least two species of the creature (which he styled *Eremotherium*), one in the northern and another in the southern ocean.—Notes on Ophidiidae and Pterascridae, with descriptions of new species from America and the Mediterranean, by F. W. Putnam.

## PARIS

Academy of Sciences, Dec. 21.—M. Frémy in the chair.—The following papers were read:—New theory of the motion of the planet Neptune: remarks on the ensemble of the theories of the eight principal planets, Mercury, Venus, the Earth, Mars, Jupiter, Saturn, Uranus, and Neptune; by M. Le Verrier. The paper presented completes a work commenced on September 16th, 1870.—New theorems on series of similar triangles, by M. Chasles.—On the limited oxidation of the hydro-carbons: amylene; by M. Berthelot. The author employs a solution of chromic acid as the oxidizing agent. Hydride of amylene yields valericianic acid. Amylene when mixed with water and treated with the mixture yields a mixture of all the fatty acids from formic to valericianic—the latter and acetic acid being formed in the greatest proportions.—New documents on the flora of New Caledonia, by M. Ad. Brongniart.—On the carpellary theory according to the Liliaceæ, by M. A. Frcul.—The Laboratory of Experimental Zoology at Roscoff, by M. H. de Lacaze-Duthiers. The author gives a detailed account of this valuable establishment.—Micrometric measurements of the triple star  $\zeta$  Cancri, by M. Otto Struve.—Report on a memoir by M. Sarrau, entitled, "Theoretical researches on the effects of gunpowder and explosive substances," by the Commissioners, MM. Morin, Tresca, Berthelot, and Réal.—On an apparatus for measuring gases in industrial analyses or *gas-hydrometer*, by M. E. J. Maumené.—Observations concerning a recent communication by M. A. Cornu on the degree of precision of Foucault's method for measuring the velocity of light; a letter from M. Lissajous to the perpetual secretary. The writer gave the following extract from Foucault in contradiction to M. Cornu's statement that the former had obtained results having an indeterminate approximation: "Increasing thus the length of the luminous path and applying greater accuracy to the measurement of the time, I obtained

determinations of which the extreme variations do not exceed  $\frac{1}{10}$  and which combined by the method of means rapidly give series which agree nearly to  $\frac{1}{10}$ ."—On the pyruvic urides: synthesis of parabanic acid; by M. E. Grimaux. This acid has been obtained by the action of bromine and water on mononitro-pyruvic uride:—

$$C_4H_5(NO_2)O_2 + 6Br + H_2O = CBr_3NO_2 + C_3H_5N_2O_3 + 3HBr.$$

On a fragment of cranium seeming to indicate that trepanning might have been employed among the Celtic people, by M. E. Robert.—M. Dumas read a telegram from M. Fleuriat relating to the transit of Venus.—Installation in Campbell's Isle of the expedition sent to observe the transit of Venus; a letter from M. A. Boquet de la Grye to M. Dumas.—Letter to the perpetual secretary on the subject of the obelisk raised at Montmartre in 1736 for the fixing of the meridian of Paris, by M. F. Lock.—On the first method given by Jacobi for the integration of equations to the partial derivatives of the first order, by M. G. Darboux.—On the changes of brilliancy of Jupiter's satellites, by M. C. Flammarion.—On the molecular equilibrium of solutions of chrome alum, by M. Lecoq de Boisbaudran.—Preparation of pure nickel salts from the nickel of commerce, by M. A. Terrell.—Action of chlorine on perbromide of acetylene, by M. E. D. Arguin.—Toxicological search for potassium cyanide in presence of non-toxic double cyanides, by M. E. Jacquemin. Researches on the pathological albumens, method of estimating albumens, &c., by J. Birot.—Analysis of a meteorite which fell in the province of Huesca, in Spain, by M. F. Plisani.—Observations relating to the Roda meteorite, by M. Daubrèe.—Researches on the modifications which the blood undergoes in its passage through the spleen, from the double point of view of its richness in red globules and its respiratory capacity, by MM. L. Malassez and P. Picard.—Observations made at Bordeaux of two lunar halos of remarkable intensity on the 15th and 19th of December; a letter from M. G. Lespialt to the president.—During the meeting M. Da Moncel was elected a free member in place of the late M. Roulin.

## BOOKS AND PAMPHLETS RECEIVED

BRITISH.—A Sketch of Philosophy. Part 4. Biology and Theodicy; a Prelude to the Biology of the Future: John C. Macvicar, M.A., LL.D., D.D. (Williams and Norgate)—Gardener's Year-Book for 1875: Robert Hogg, LL.D. F.L.S. ("Journal of Horticulture")—Hereditry: From the French of Th. Ribot (Hy. S. King and Co.)—Geology of the Clyde Valley: John Young, R.D. (James Macmillan, Glasgow)—List of the Palæozoic Fishes. Extracted from the Geological Magazine (Triübner and Co.)—Seventh Annual Report of the Executive Committee of the Manchester Nat. Soc. for Woman's Suffrage (Alexander Ireland, Manchester)—Notes on a Till or Border Clay with broken Shells in the Lower Valley of the River Endrick: Robt. L. Jack, F.G.S. (Geological Society, Glasgow)—Astronomy: J. Norman Lockyer (Macmillan and Co.)—The Physics and Philosophy of the Senses: K. S. Wyl, F.R.S.E. (Henry S. King and Co.)—Cholera: How to Prevent and Resist it: T. Whiteside Hime, A.B., M.B., &c. (Baillière, Tindall, and Cox)—Studies on Biogenesis: Wm. Roberts, M.D. (Royal Society)—On the Connection between Colliery Explosions and the Weather in 1872: Robert H. Scott and Wm. Galloway (Quarterly Journal of the Meteorological Society)—British Wild Flowers, Parts 7 and 8: John E. Sowerby (John Van Voorst)—History of British Birds, Parts 6, 7, and 8: A. Newton, M.A., F.R.S. (John Van Voorst)—Micrographic Dictionary. Parts 18, 19, 20, and 21: J. W. Griffith, M.D., and A. Henfrey, F.R.S., F.L.S. (John Van Voorst)—Anthropologia. Vol. 1. Part 3 (Baillière, Tindall, and Cox).

## CONTENTS

	PAGE
GALTON'S "ENGLISH MEN OF SCIENCE." By Prof. W. STANLEY	161
JEVONS, F.R.S. "ON THE THEORY OF THE ENGLISH PEOPLE"	164
FENLING'S NEW CHEMICAL DICTIONARY. By M. M. PATTISON MUIR	165
OUR BOOK SHELF:—	
Reuss's "Fossil Diprozoa"	166
Hoernes' "Geology of Samothrace"	166
Alth's "Palæontology of Podolia"	166
Mojzsis's "Draconia" and "Halobia"	166
LETTERS TO THE EDITOR:—	
On the Inventor of Clock Movement applied to Equatorials.—Suom Quique.	166
The Potato Disease.—Prof. W. T. THIRSPLET DYER.	167
Mr. Cutler and Section Cutting.—Prof. W. C. WILLIAMSON, F.R.S.	167
Snakes and Frogs.	167
THE ANDERSON SCHOOL OF NATURAL HISTORY.	167
THE LAST TYPHOON AT HONG KONG.	168
ENGEL'S COMET. By J. R. HULL, F.R.S.	175
FERTILISATION OF FLOWERS BY INSECTS. IX. By Dr. HERMANN MULLER (With Illustrations).	169
THE TRANSIT OF VENUS.	171
THE SECTROSCOPE AND THE TRANSIT OF VENUS.	171
THE PRESENT CONDITION OF THE ROYAL SOCIETY.	173
FRENCH ACADEMY OF SCIENCES—ANNIVERSARY MEETING.	178
SCIENTIFIC SERIALS.	178
SOCIETIES AND ACADEMIES.	179
BOOKS AND PAMPHLETS RECEIVED.	180

THURSDAY, JANUARY 7, 1875

## THE GEOLOGICAL SURVEY OF VICTORIA

*Geological Survey of Victoria.* Prodr omus of the Palæontology of Victoria ; or, Figures and Descriptions of Victorian Organic Remains. Decade I. By Frederick M'Coy, F.G.S., Government Palæontologist, and Director of the National Museum of Melbourne. (Melbourne: John Frères. London: Trübner and Co., 1874.)

WE have at last a first instalment in the shape of a Decade, from Prof. M'Coy, of Melbourne, Australia, upon the organic remains of that colony. It is entitled, "Prodr omus of the Palæontology of Victoria, or Figures and Descriptions of Victorian Organic Remains," Decade I. The preface, by Prof. M'Coy, states that as the maps and sections of the Australian Survey would be incomplete without figures and descriptions of the fossil organic remains, it has been determined to issue a Prodr omus or preliminary publication of the Victorian fossils, in decades or numbers of ten plates each, with descriptive letterpress. The first decade contains matter illustrating six different groups of fossils ; viz., the Graptolites, the Marsupiata, the Mollusca (Gasteropoda), gymnospermous and lycopodiaceous plants, and Star-fishes of the family Urasteridae. We presume that this mode of issuing the decade is an experimental one, as it will require eight or ten numbers of decades to complete one decade of a particular group, depending upon the number of plates devoted to these particular groups as they are issued. We should have preferred seeing a decade on the Graptolitiidæ completed at once, or the Asteriada, or Volutiidæ, or indeed any other, thus forming almost a monograph of some special group, as a connected whole, as it will be long before a decade of any one group can be hoped for, unless the Professor has a large stock in hand, and store already prepared. If there is one group more interesting than another, figured in the decade, it is the Graptolites : the Victorian species figured are nearly all British, European, and American ; no extinct organisms of apparently the same species had so wide a distribution in space. Hall, of America, Carruthers, Hopkinson, Lapworth, Nicholson, Baily, &c., have all elaborately written (indeed still are writing) upon these mysterious Hydrozoa ; and Prof. M'Coy, of Victoria, and Etheridge, of Edinburgh, are now investigating the Victorian forms. Surely something definite may be expected, or will be determined, as to their specific value. Monopriionidian forms of the genus *Diplograpsus* and *Didymograpsus* are the only genera touched upon in the decade ; also one *Phyllograptus*, *P. folium*, var. *typus* Hall, which differs little from our British species, except in being larger. M'Coy describes ten species, four of which are British of Lower Silurian age. Our own gold-bearing Cambrian slates of North Wales thus contain a fauna, the same in time as those "goldfield slates" of our auriferous colony.

Plates 3, 4, and 5 of the decade and text are devoted to descriptions of the mandibulæ or jaws of one genus of marsupial mammalia of Australia, *Phascalomyia pliocenus* (Wombat). The mandibles only are figured and described. The chief interest attached to this fossil arises from its being the first ever found in the Victorian fer-

ruginous gold drifts or gold cement of Dunolly. Prof. M'Coy fixes the age of the deposit as Pliocene Tertiary, corresponding in time with our upper crags of Norfolk and Suffolk, and he believes the Victorian beds correspond in age with the gold drifts of the Ural chain.

*Macropus titian* and *M. atlas*, extinct forms of Kangaroo, occur with this fossil form of Wombat. We look forward to much original matter from Prof. M'Coy upon the phytophagous and carnivorous marsupials of the Australian continent.

Plates 6 and 7 of the Volutiidæ, especially certain forms, are scarcely distinguishable from the Middle Eocene species of our own country (Barton and Bracklesham) ; and the higher Oligocene Tertiaries of Europe are represented in these distant Cænozoic deposits of the antipodes. The *Voluta anti-cingulata* of M'Coy seems to us to realise the alliance of our two British species—*V. ambigua* and *Voluta digitalina*. We have again a representative form in *V. antisularis*, M'Coy, occurring in the Tertiary and Oligocene clays of Modop and Mount Martha. The *Vololithes scalaris*, Sow. (Middle Eocene of Isle of Wight and Barton) and the *Voluta nodosa*, Sow. (Bracklesham and Barton) are so closely allied to those Australian Volutes that we fail to see any difference ; they are truly representative. The remarkable shells, *V. macroptera*, M'Coy, and *V. Hannafordi*, M'Coy, are essentially new forms, and throw fresh light upon the specific value of the genus ; the great expansion and globose nature of the wing or lip removes it from our British Crag *Voluta Lambertii*, but to which in many other respects it is allied.

Part VIII, with Plate 8 is devoted to the description of eight species of Zamites (Podozamites). This group of gymnospermous plants are of much interest to the palæophytologist, and, in this country and Europe, essentially typify and characterise rocks of Secondary or Mesozoic age. The discovery in Queensland of a bipinnate or distichous *Zamia* (Bowenia) has changed our views as to the foliage of this group of Cycadaceæ, now known to be compound instead of simple. M'Coy proposes the sub-generic name of *Bowernites* for these compound fossil Cycadaceæ resembling the recent Bowenia. The fruit found with the remains does not aid the Professor in determining their true affinity, but he states they more strongly resemble the fruit of the fossil *Zamia* of our Yorkshire oolites than the Araucarian type. The fossil or extinct British Cycadaceæ had long range in time, commencing in the Lias and living through all the Secondary rocks ; *Fittonia*, of the Upper Cretaceous beds, being the last British form. The group is largely represented by many species in our Wealden and Purbeck rocks.

Part IX, and plate accompanying it illustrate one genus of lycopodiaceous plants (*Lepidodendron*). This ubiquitous genus occurs in the coal measures in every region of the globe, and frequently in the Upper Devonian rocks, but at the close of the Palæozoic period passed away. There is much conflicting evidence and information relative to the occurrence of this group of lycopods in the true coal measures of New South Wales and Victoria. Prof. M'Coy states that not one has ever yet been found in the coal strata of New South Wales or Victoria ; its occurrence in both areas named is entirely unconnected with the beds yielding the coal. M'Coy believes that the



coal-yielding rock of the above localities are of Mesozoic age; stating his reasons from the entire absence of Calamites and Lepidodendrons, and from the presence of *Tænioptera*, *Phyllotheca*, and other forms intimately related to those of the Mesozoic coal-beds of the oolitic formations of Yorkshire, Europe, Richmond (America), and India. That rocks of true Coal-measure age do occur in Australia there is no doubt; we cannot here discuss the fragmentary and conflicting evidence of its presence and distribution until more reliable data has been collected.

Plate 10 illustrates two species of star-fishes from the Upper Silurian rocks, *Pteraster* and *Urasterella*, both of the family *Urasteridae*. M'Coy's *Urasterella* is the *Stenaster* of Billings and Palcaaster of Hall; and to this latter genus have been referred those forms of old star-fishes having adambulacral, ambulacral, and marginal plates on the arms, whereas *Urasterella* differs in only having one row of plates on each side of the ambulacral groove. The two forms figured in the decade are named after the present mining and late geological directors of the colony. *U. selwynii* appears to be the first fossil star-fish found in Australia. These star-fishes, like many other Australian fossils, are almost identical with our British types. We know of no more remarkable fact in the history and distribution of life than the affinity that seems to exist between the forms of life over two areas so old and so vastly removed as that of Britain and Australia, antipodal to each other; universality might almost be applied through Homotaxis to the geographical distribution of the several formations which comprise the periods even stratigraphically and lithologically; as well as the existence in common of numerous genera, and with many representative and some even identical species between the two countries. What difference in time there might have been between the deposition of the sedimentary materials and its accompanying life in our European or the American area, with that of the Australian region, we shall never know; but the faunal relations were nearly the same, and the then species must have had a far wider distribution [in space and time than we have hitherto imagined or generally believed.

This first Decade of Victorian Fossils will be studied with much interest by British palæontologists, firstly on account of its being from the pen of the accomplished Director of the National Museum of Melbourne, and secondly on account of the valuable researches and matter forwarded to us illustrating the palæontology or past life history of that remote region of the globe.

#### LIVINGSTONE'S "LAST JOURNALS" \* II.

*The Last Journals of David Livingstone in Central Africa, from 1865 to his Death. Continued by a Narrative of his last moments and sufferings, obtained from his faithful servants, Chuma and Susi.* By Horace Waller, F.R.G.S., Rector of Twywell, Northampton. In two vols. With portrait, maps, and illustrations. (London: John Murray, 1874.)

THE Loangwa was crossed on December 15, and on Christmas Day Livingstone lost his four goats, a loss which he felt very keenly; "for, whatever kind

of food we had, a little milk made all right, and I felt strong and well, but coarse food, hard of digestion, without it, was very trying." Indeed, after this Livingstone suffered much from scarcity of food, and became greatly emaciated and weakened; and to intensely aggravate this, through the weakness of a boy and the knavery of a runaway slave, the medicine chest was stolen on January 20, 1867, a loss which was utterly irretrievable. "I felt," he sadly says, "as if I had now received the sentence of death, like poor Bishop Mackenzie." Fever came upon him shortly after, and for a time became his almost constant companion; and this, with the fearful dysentery and dreadful ulcers and other ailments which subsequently attacked him, and which he had no medicine to counteract, no doubt told fatally on even his iron frame, and made it in the end succumb to what he might otherwise have passed through with safety.

The Chambezi, whose course into Bangwecolo Livingstone has finally determined, was crossed on January 28. While detained for about three weeks at the village of Chitapangwa, a somewhat able and on the whole well-meaning chief, he sent off a packet of letters and despatches with some Arab slaves; these reached England in safety. He also sent forward a small supply of provisions to Ujiji. At last the southern shore of Tanganyika (or Lake Liemba, as the south part is called) was reached on March 31. By this time Livingstone was so weak, he could not walk without tottering. At the village of Chitimba, some distance west of the end of the lake, he was detained for upwards of three months, on account of a quarrel between a chief, Nsami, and the Arab Kamees, whom Livingstone found here with a slaving party, and who showed the traveller much kindness. On Aug. 30, difficulties having been adjusted, Livingstone proceeded westwards, and on Nov. 8 came upon the north end of Lake Moero, "a lake of goody size, flanked by ranges of mountains on the east and west. Its banks are of coarse sand, and slope gradually down to the water; outside these banks stands a thick belt of tropical vegetation, in which fishermen build their huts. The country called Rua lies on the west, and is seen as a lofty range of dark mountains."

Proceeding southwards, Cazembe's, on Lake Mofwe, a lakelet a little south of Moero, was reached in a few days. The name of Cazembe is already known in connection with the journey, in the end of last century, of Dr. Lacerda, who died and was buried not far from the present village. This Cazembe (he was killed shortly after Livingstone's visit) was the tenth from the founder of the dynasty, who came from Lunda, and conquered the then reigning chief, usurping the chiefship. Cazembe treated Livingstone on the whole handsomely. The traveller remained at his village about a month, when he again went to the north of Lake Moero, and visited the Lualaba, the river which, rising in Lake Bangwecolo as the Luapula, and of which the Chambezi may be considered the beginning, stretches about northwards and westwards through Lake Kamolondo, and again northwards, to what termination is not yet known. Livingstone had a firm belief that it was the upper part of the Nile, though appearances would seem to suggest that it more probably joins the Congo. There is every likelihood that Lieut.

\* Continued from p. 145.



Cameron will be able ere long to solve the mystery. To this river Livingstone has given the name of his friend Webb, and to an important tributary from a reported large lake to the west, named by Livingstone Lake Lincoln, and made to join Lualaba about 3° S. lat., he has given the name of his staunch friend "Sir Paraffin Young." Livingstone again came south to Cazembe's in May 1868. Before this all but five of his men deserted to a slave party under Mohamed bin Saleh, who had been detained ten years at Cazembe's, and whom Livingstone helped to get off. He turned out an ungrateful cheat. Continuing southwards in June, Livingstone on July 18 reached Lake Bangweolo, although he was not really its first European discoverer, the Portuguese having been there long before him. With difficulty obtaining a canoe, he crossed to an island some miles off the north-west corner of the lake. The latter he calculates to be about 150 miles long by 80 broad, and is 3,688 feet above the sea. It, as well as Moero, abounds in fish of a great variety of kinds, some of which, no doubt, will ultimately be found new to science. Livingstone had no means of bringing away any specimens, and only gives the native names. As we have said, the north-east, east, and south sides of the lake are surrounded with "sponges," the water in many places being so deep as to require canoes, and is intersected by the courses of many streams. On islets in this sponge the villages are located.

In connection with this "sponge" and the rainy season, Livingstone enters in this part of his journal on a long disquisition on the climate of Central Africa, which we recommend to the notice of meteorologists. Speaking of the region around Bangweolo, he says "burns (*Scotied* for 'brooks') are literally innumerable: rising on ridges, they are undoubtedly the primary or ultimate sources of the Zambezi, Congo, and the Nile; by their union are formed streams of from thirty to eighty or one hundred yards broad, and always deep enough to require either canoes or bridges. These I propose to call the secondary sources, and as in the case of the Nile they are drawn off by three lines of drainage, they become the head waters (the *caput Nili*) of the river of Egypt." No one had a better right to theorise on this subject than Livingstone, for few had observed so much; but it may yet be found that he allowed his eagerness to settle the Nile question to run away with his cooler judgment.

After being detained near Bangweolo for some time by the disturbed state of the country, he proceeded northwards in the company of some Arab traders. Still further delay occurred to the north of Moero, caused by the barbarity of the Arab slavers with whom he was compelled to travel, and it was not till December that a start in earnest was made north-eastwards to Tanganyika. He became so ill on the road with pneumonia and other ailments, resulting from damp and a completely enfeebled constitution, that he became insensible and had to be carried part of the way. The effects of this illness never left him. The lake was reached in February 1869, and Livingstone entered Ujiji on March 14, a "ruckle of bones." Supplies had been forwarded to him here from Zanzibar, but his misfortunes were aggravated by finding that most of them had been knavishly made away with by those to whose care they had been entrusted.

The traveller re-crossed Tanganyika in July, and on August 2 set out on a new series of discoveries to the west of the lake, in a region not before visited, scarcely even by the Arabs, that of the Manyema. Through this region flows into the Lualaba the large river Luamo, or Luasse, or Lobumba, rising close to the west shore of Tanganyika. Livingstone's object was to reach the Lualaba and if possible cross to the west side. After vainly trying to get west, he went into winter quarters in February 1870, at Mamohela, in about 4° 20' S. lat. and 27° 5' E. long. Another attempt was made to reach the river with only Chuma, Susi, and Gardner. He was again baffled and returned to Bambarre, south-west of Mamohela, in July, martyred with irritable eating ulcers in the feet, which seem to be caused by some form of malaria, and with which he was for long sorely troubled; he was confined to his hut for eighty days with them. During his long detention here, which galled Livingstone dreadfully, he records many observations of the people, who certainly seem to eat human flesh, and prefer it when very "high," but who were on the whole extremely kind to himself, notwithstanding the brutal usage given them by the Arab traders, with whom the country now swarmed, and who mercilessly burned villages and slaughtered men, women, and children, simply to inspire terror. Here Livingstone became acquainted with what Mr. Waller thinks is an entirely new species of chimpanzee, a remarkable animal called by the natives the "Soko," possessing wonderful intelligence and having some very curious habits. In February 1871, some men who proved worthless scoundrels reached him from the coast, and he again started for the Lualaba, which at last he reached on March 29. He stayed at a village, Nyangwe, for four months, vainly trying to get a canoe to take him to the other side, which was here 3,000 yards off, the bed of the river being dotted with many islands. This Nyangwe at which Livingstone stayed is a place of great interest; a regular market is kept daily to which hundreds of women from the other side flock to buy and sell goats, sheep, pigs, slaves, iron, grass cloth, salt fish, earthen pots, &c. The devilish treachery of the Arab slavers seems to have reached its height here during Livingstone's sojourn. A party under one Dugumbé, without warning or provocation, assembled one day when the thronged market was at its height, and commenced shooting down the poor women right and left, so that between those who were shot and those who were drowned, hundreds were killed, and the market completely broken up. No wonder that Livingstone had "the impression that he was in hell," and that his "first impulse was to pistol the murderers." This of course completely knocked on the head any chance which he may have had of getting a canoe, and in sickening disgust he made his way back to Ujiji, which he reached on October 23. While returning through Manyema, his party was attacked by the enraged people, who mistook Livingstone for one of the slavers, and nearly stopped his further travels by a spear which grazed his back. This was the only time during these last seven years' wanderings that the traveller was hostilely attacked. Five days after his arrival at Ujiji he was cheered and inspired with new life, and completely set up again, as he said, by the timely arrival of Mr. H. M. Stanley, the richly-laden

almoner of the proprietor of the *New York Herald*. Mr. Stanley's story is known to everyone, and we need not repeat it.

With Stanley, Livingstone explored the north end of Lake Tanganyika, and proved conclusively that the Lusize runs into and not out of it. It will be satisfactory if the discovery of an outlet on the west side, just announced in a despatch from Lieut. Cameron, turns out to be true. In the end of the year the two started eastward for Unyanyembe, where Stanley provided Livingstone with an ample supply of goods. Here Stanley urged his going home, but although he was now inwardly yearning to return, his judgment said, "All your friends will wish you to make a complete work of the exploration of the Nile before you retire." To this purport also was the advice of his daughter Agnes, whom he therefore calls "a chip of the old block." But had his judgment been cool enough, it might have told him that his constitution was so shattered that it was totally unequal to a task of such magnitude. The fountains he was in search of he supposed to be about 400 miles to the west of Lake Bangweolo.

The rest is soon told. Stanley left on March 15, and after Livingstone had wearily waited in Unyanyembe for five months, on August 15 a troop of fifty-seven men and boys arrived, some of the boys being Nassick pupils from Bombay, one of whom was Jacob Wainwright, who afterwards acted so important a part in the home-bringing of his body. Thus attended, then, he started on August 25 for Lake Bangweolo, proceeding along the east side of Tanganyika, over rugged mountains which sorely tried the endurance of himself and his retinue, even though he had two donkeys to ride, a present from Mr. Stanley. His weakness soon found him out; ere he reached the shore of Tanganyika his old enemy dysentery seized upon him, and seems never wholly to have left him, but to have got worse and worse, causing him fearful suffering till the bitter end. In January 1873 the party got among the endless spongy jungle on the shores of Bangweolo, where vexatious delays took place, and where the journey was one constant wade below, and under an almost endless pour of rain from above. The Chambezi was crossed on March 26, and the doctor was getting worse and worse, losing great quantities of blood daily; but he seems never to have dreamed of turning back or of resting. No idea of danger seems to have occurred to him; he had so often before got over difficulties and attacks of all kinds, and he was so full of the object his heart was bent on, that the idea of death does not seem to have entered his head. This, we believe, moreover, is a characteristic of the disease. At last, in the middle of April, he was unwillingly compelled to allow his men to make a *kitanda*, or rude litter, in which he was borne to the end. Still the dreadful illness is spoken of as a mere annoying hindrance. Thus, on the 25th of April, Chitambo's village on the Lulimala, on the south of the lake, was reached. The last entry in the journal, of the last two pages of which a fac-simile is given, is April 27: "Knocked up quite, and remain—recover—sent to buy milch goats. We are on the banks of the Molilamo." On April 30 he was careful to wind his watch, but with the utmost difficulty, and early on the morning of May 1 he was found by the boys kneeling by the side of his bed, dead.

Chitambo behaved generously, and the men, headed by Chuma and Susi, acted with great intelligence, faithfulness, and discretion. Everything was carefully locked up, and the story of the preparation of Livingstone's body for the purpose of carrying it home to his own folk, by "beekin' forenent the sun," is known to all. After a five months' march through many difficulties, the attendants reached Unyanyembe. Here Lieutenants Cameron and Murphy and Dr. Dillon were met, and early this year the body arrived at Zanzibar, and in the end of April was deposited, as was meet, in Westminster Abbey.

A monument with an appropriate inscription has been erected to Livingstone in the Abbey; and doubtless, in time to come, a more suitable memorial will take the place of that rude one placed near the spot where their hero died, by the hands of his loyal and faithful attendants.

Mr. Waller, we think, has on the whole performed his sacred task judiciously, printing the journals, as we have said, exactly as he found them, though many of his parenthetical remarks seem to us unnecessary. The maps are of great assistance to the reader, and will be found of value to the geographer, although in the meantime, so far as Livingstone's last journey is concerned, they must be regarded as to a great extent conjectural. No doubt careful criticism will soon do its work both on journal and maps, and, with the help both of previous and subsequent exploration, test the exact geographical value of the achievements which cost Livingstone his life. The illustrations are interesting and helpful.

#### BUCHANAN ON THE CIRCULATION OF THE BLOOD

*The Forces which carry on the Circulation of the Blood.*

By Andrew Buchanan, M.D. Second Edition. (London: J. and A. Churchill, 1874.)

IN the same way that, among *à priori* mechanical philosophers, the possibility of discovering a perpetual motion was a favourite subject of discussion before the development of the theory of energy, so, among physiologists, the relative importance of the different forces which maintain the circulation of the blood was an equally common source of speculation before the introduction of the blood-pressure gauge and the sphygmograph. Within the last twelve or fifteen years, however, the various problems which used to occupy the attention of Magendie, Arnott, and Barry have been completely solved by entirely fresh methods of observation; and these, quite irrespective of their *opinions*, have verified or disproved their theoretical deductions according to whether or not they were based on sound premises.

Dr. Buchanan devotes much of the short work before us to the consideration of one of these bygone points, namely, the pneumatic forces which maintain the circulation of the blood, the importance of which he endeavours to demonstrate by a series of hydraulic experiments, the different elements of which are, we fear, slightly savoured with the bias of preconceived notions, as the result at which he arrives is that "after birth the circulation is mainly carried on by two forces—the propulsive force of the heart and the pressure of the atmosphere, acting nearly in the proportion of three of the former to two of the latter; but that as life advances, and the quantity of

venous blood increases, the latter force becomes relatively more powerful." The most energetic of these auxiliary pneumatic forces is stated to be that of the chest, which is followed in importance by the suction force of the heart and by a "pleuro-cardiac pneumatic force," in which the heart, contracting in a rigid chamber, draws blood into it from the surrounding veins, on account of its decrease in size during the systolic act. The elaborate investigations of MM. Chauveau and Marey,\* published a little more than ten years ago, put us in a position to state exactly, in inches of mercury, what are the values of the pneumatic forces which Dr. Buchanan describes; and as these results are evidently not familiar to British physiologists, to those at Glasgow at least, it may be worth while recapitulating them here. First, the sphygmograph trace in health shows that, as Dr. Arnott maintained, normal respiration has scarcely any appreciable effect on the blood-pressure, because the horizontal line joining corresponding points in the different pulse-beats is very nearly, if not quite, straight. These authors also explain how the antagonistic results of Ludwig and Vierordt—in which the one states that the blood-pressure falls during inspiration, and the other during expiration—can be accounted for; they finding that if the air-passages are partially obstructed, as by shutting the mouth and closing one nostril, the one result is produced; whilst if these same passages are freely opened, the opposite effect is observed. The influence of respiration may therefore be dismissed as comparatively insignificant.

That of the heart is much more considerable. By means of a beautifully constructed piece of apparatus M. Marey has been able to demonstrate the existence and amount of the negative or suction forces, as far as they are found to exist in the different cavities of the heart, during the different parts of each cardiac pulsation. His results are recorded by the graphic method,† and their agreement among themselves is evidence of their accuracy. The work referred to contains a full description of the apparatus employed. The following are the results:—In the right ventricle the blood-pressure does not ever go beyond zero, except at its basal portion, where it is *sometimes* found that a minute suction force develops immediately after the closure of the aortic valves, and then only. In the left ventricle an appreciable suction force is observed at the same time as in the right; it is, however, not great. It is impossible, by any means yet devised, to get at the left auricle, but the right auricle is easily arrived at from the jugular vein. In it the blood-pressure is *nearly always* negative or below zero, it being otherwise only during its systole. A study of the auricular cardiograph trace shows that immediately after the auricular systole, which is the same thing as saying at the commencement of the contraction of the ventricles, the pressure in the auricle descends rapidly below zero; that the descent is broken by a small wave, and that the suction force commences to diminish gradually after the closure of the aortic valve, becoming *nil* a very short time before that organ again contracts. The explanation of these changes is not difficult. The rapid fall in the auricular pressure during the ventricular contraction was many years ago fully explained in a peculiarly able

memoir by Mr. Bryan,\* and the active dilatation of the ventricles of the heart during diastole, which necessitates a corresponding internal suction force, has been shown by more than one physiologist to depend on the peculiarities of the coronary circulation.

By employing a specially adapted manometer M. Marey was able to measure this suction force in the right auricle of *Equus caballus*, and found that it ranges, on the average, between  $-7$  and  $-15$  millimetres of mercury, the same method giving 120 millimetres as the average pressure in the left ventricle during the systole. From these figures the true relation borne by the contractile force of the heart to its suction power can be readily estimated.

The "pleuro-cardiac pneumatic force" described by Dr. Buchanan is nothing more than that above referred to as described by Mr. Bryan, the latter author having previously demonstrated that on account of the heart—a conical organ—contracting in a conical cavity, it must necessarily advance towards the apex of that cone during systole, and so leave the base to be filled by the absorption of the blood from the distended veins.

These remarks all tend to show that many of Dr. Buchanan's investigations are in the right direction, but that a further acquaintance with the literature of the subject would enable him to employ his considerable ingenuity and enthusiasm in the elucidation of points still remaining unexplained to students of the science of physiology. This want of acquaintance with the works of others is, we think, partly explained by some incidental remarks in the book before us. The author says: "I have always exercised all the branches of my profession. . . . I cannot but regard this custom as much superior to that which our medical corporations are now enforcing, of making every man from the beginning select for himself a single branch of the profession;" to which are added other remarks derogatory to specialisation in study. With these we cannot agree, and still think that "if you wish to find a man of large views of physiological nature," he is more likely to be a special student, with time at his disposal, unoccupied by miscellaneous professional calls, than one who, turning his attention to all things, has no opportunity of concentrating it on any one, to the advancement of our knowledge of its details.

#### OUR BOOK SHELF

*Elements of Animal Physiology.* Elementary Science Series. By J. Angell. (W. Collins and Co., 1874.)

There is more than one way by which the relative importance of scientific facts may be arrived at. An investigator, whilst prosecuting his independent researches, will not be long in forming a fairly accurate standard, and this he finds it easy to impart to others. Many engaged in educational work find it impossible to afford the time for independent observation or prolonged study, and yet it is their ambition to give their pupils a fairly correct estimate as to those of the innumerable facts surrounding them on which they should lay stress in preparing for a pass examination. The standard with them therefore becomes nothing more nor less than the questions of former years or of other similar examinations; the work which answers the greatest number of these in the most satisfactory manner being looked upon as the most

\* Marey, "Circulation du Sang;" Paris, 1863.

† *Loc. cit.* pp. 95, 96.

\* *Lancet*, Feb. 8, 1834.

valuable, especially if the irrelevant matter is reduced to a minimum. The small book before us contains a carefully compiled and accurate digest of many of the most prominent facts of human physiology, with incidental references to some of the best known peculiarities of a few of the lower animals, illustrated by several appropriate and well-selected diagrams, among which, however, there is an important one indicating the general distribution of the arterial system, which is unfortunately reversed, and another explaining the leverages of the body, representing a man as standing with his centre of gravity far in front of the tips of his toes. The language employed is clear and concise, whilst many of the best known terms in common use among physiologists are explained in a glossary at the end of the book. Some of the practical illustrations suggested to the pupil for his own instruction are particularly to the point. There are some explanations with which, however, we cannot agree, such as that the activity of the circulation of the blood which accompanies physical exercise is the result of the alternate compression and relaxation of the veins; and that a much vaunted theory as to the cause of cholera, which involves the purchase of a much advertised apparatus for its relief, has sufficient foundation for even the slightest mention in any book for the use of students. The non-technical character of the work will commend it to many as a useful introduction to physiology.

*The Gardener's Year Book and Almanack, 1875.* By Robert Hogg, L.L.D., F.L.S. (*Journal of Horticulture Office.*)

THIS is a very handy and valuable little book. The information it contains is of a kind that may be thoroughly depended upon. Besides a great deal of practical information of a miscellaneous sort, there are tolerably copious gardening directions for each month, besides selected lists of fruits and vegetables, and of the new plants of last year. It will be very useful to amateur gardeners, and would be still more so if it gave some short and plain descriptions of various horticultural operations—such, for example, as pruning different kinds of fruit-trees.

#### LETTERS TO THE EDITOR

[*The Editor does not hold himself responsible for opinions expressed by his correspondents. Neither can he undertake to return, or to correspond with the writers of, rejected manuscripts. No notice is taken of anonymous communications.*]

#### Absence of Microscopic Calcareous Organic Remains in Marine Strata charged with Siliceous Ones

In a letter headed "Deep-Sea Researches," and subscribed "W. C. Williamson, Owens College," in your issue of the 24th Dec. (vol. xi. p. 148), the author, after having stated that Dr. Wyville Thomson has come to the conclusion that the calcareous Globigerine and other such elements had been removed by the "solvent action of carbonic acid accumulated in the deep-sea waters," adds that, "In my memoir [1847, *op. cit.*] I arrived at the same conclusion."

Then follow extracts from the "Memoir" itself, alluding to the removal of all the calcareous forms, leaving only the siliceous structures," by "carbonic acid gas in solution in water."

Finally, the author states:—"After venturing upon these conclusions in 1847, not as mere speculative guesses, but as the deliberate result of a long series of investigations carefully worked out, I need scarcely say how intense was the interest with which I read Dr. Wyville Thomson's observations, which so thoroughly sustain and confirm the accuracy of mine. My conclusions were wholly derived from the microscopic observations of earths and rock specimens which I compared with the few examples of foraminiferous ooze with which I was then familiar."

"Felix qui potuit rerum cognoscere causas."

In enumerating the different kinds of destruction which take place in sponge-spicules generally, I have noted that the calcareous spicule is subject to one in particular, "in which there is a general breakdown of the whole fabric, which gradually

becomes resolved into a group of aqueous-looking globules, of different sizes, among which there is not a trace of the original structure to be seen. Were this change confined to those calcareous spicules which I have mounted in Canada balsam, I should have inferred that it was caused by the balsam; but I find that the same change accompanies these spicules where they may have been taken in by the kerataceous sponges to form an axis for their horny fibre; and it is worthy of remark that the spicules of the Echinodermata, which may lie side by side with them, do not appear to be similarly affected. Of what nature the origin of this disorganisation may be I am ignorant; it is a chemical question; but the destruction takes place so rapidly in many instances that I have for some time past ceased to mount any more calcareous spicules, and now preserve a record of them by immediate sketches." (*Ann. and Mag. of Nat. History*, vol. xii. 1873, p. 457.)

Thus it follows that a removal or an annihilation of the forms of these microscopic calcareous organisms takes place after they have been repeatedly washed in fresh water, dried under a great heat, and covered at the same time with balsam, that is, treated artificially; as well as naturally, when they are mixed up with other microscopic organisms to form the core of the horny fibre of marine sponges; while the same thing takes place with the Foraminifera, as testified by slides, in some of which fragments of *Operculina arabica* mounted upwards of twenty years ago have nearly all passed into dissolution, and others in which the spicules of calcareous sponges which were mounted not more than six years since have disappeared altogether, leaving nothing but a few aqueous-looking globules in their places respectively.

So that this dissolution may arise without the presence of "carbonic acid gas in solution in water;" and as it is common to the calcareous organisms mounted in balsam for the cabinet, as well as in the core of horny fibre in the marine sponges of the "deep-sea," we may fairly assume that the removal of the calcareous forms from the siliceous ones in marine deposits may be due to more causes than that assigned by the author of the letter to which I have alluded.

Moreover, even the siliceous spicules which form the core of the glassy fibre in the vitreous sponges may, with the circumjacent layers of the fibre itself, undergo absorption to such an extent, in the skeleton of these sponges, after death, as to leave nothing but a siliceous shell with hollow, continuous tube throughout.

Such are the results of my microscopic observations among these minute organisms, and therefore, in the concluding words of the letter under reference, "I think I am justified in wishing the fact to be placed on record."

Indeed, so common and rapid is the process of destruction or inherent disintegration among the microscopic calcareous organisms which I have mentioned, that I am compelled to the conclusion that it is to this chiefly, and not to "carbonic acid gas in solution in water," that we must look for a satisfactory explanation of the fact that minute calcareous organic forms are comparatively absent among the siliceous ones of marine deposits, both recent and fossilised.

The agency of decay is as difficult to comprehend as the agency of development (why we should die any more than why we should live); hence it becomes unphilosophical to limit the operations of either to any one process. All that appears certain in the matter is, that the three great attributes of the system, viz., creation, preservation, and destruction, form a cycle in which, to speak figuratively, the words "perpetual change" may be enwreathed.

HENRY J. CARTER

Buddleigh-Salterton, Dec. 26, 1874

#### The Constant Currents in the Air and the Sea

THE *Philosophical Magazine* for July, August, and September contains a memoir, continued through the several numbers, by Baron N. Schilling, Captain in the Imperial Russian Navy, on "The Constant Currents of the Air and the Sea." It appears that this memoir was first published in the Russian, afterwards in the German, and finally translated and published in the English language; so that it seems to be regarded as a memoir of considerable importance.

When any new and, extraordinary results are obtained in any department of important scientific inquiry, the interests of science require that the basis of these results should be critically examined before they are received; and this is especially so where,

as in this case, the results are entirely at variance with those of profound and elaborate researches in the same direction which have preceded. We propose, therefore, to examine briefly only a very few points in the reasoning from which these results have been deduced.

The author states in the commencement that equilibrium is disturbed by the three following causes:—

- (a.) Alteration of the specific gravity of the water or air.
- (b.) The rotation of the earth on its axis.
- (c.) The attraction of the sun and moon.

He accordingly treats the subject under these three general heads. Under the first two he endeavours to show that none of the usual causes to which the currents of the ocean and the atmosphere have been usually referred can have much, if any, effect in producing them, and that they must, therefore, be due to some other cause. This seems to be designed to make way for the introduction into this subject of the new disturbing forces contained above under the last head (c). Much might be said with regard to what is stated under the first two heads in disparagement of the forces upon which these currents have been heretofore supposed to depend, but we shall confine ourselves here to a very few steps merely in the reasoning under the last head.

The author sets out under this head by assuming that the equilibrium theory of the tides is applicable to the real case of nature, and with this assumption he endeavours to show that the flood-tide rises higher above the plane of static equilibrium than the ebb-tide sinks below it. Now, it is well known by all who are familiar with tidal theories, that this theory is entirely worthless as a representative of the real tides of the ocean. Here, then, there seems to be a weak place in the very foundation of the whole reasoning, and any results based upon it should be received with much distrust, if even all the following steps in the argument were regarded as valid. In the second place, he attempts to show, by a method which is very unscientific and inconclusive, that the forces of the sun and moon tend to produce a current from the east towards the west in the flood-tide, but the reverse of this in the ebb-tide. This is then followed by another assumption in the following language:—"Since, as we have shown, the flood rises more above the normal level of the sea than the ebb sinks below it, we think we can assume, as an hypothesis, that the force of the flood-current will be greater than that of the ebb-current." From this he infers that the difference in these forces must produce a constant current in the ocean in the torrid zone from east to west, but, for reasons which do not seem clear, the reverse of this toward the poles; and in this way, taking into account the deflections of the continents, he accounts for all the ocean currents without the aid of any of the usual causes assigned. In the case of the atmosphere he thinks that the same reasoning must hold, but admits that in this case the alteration of the specific gravity by heat toward the equator may produce some additional and modifying effects. Saying nothing with regard to the steps in the argument, these results are based upon a confessedly doubtful hypothesis, and therefore should not be received without further proof.

This is not a question to be settled by authority, but after the profound investigations of Laplace and Airy upon the tidal forces and the solution of the tidal problem, from which no constant currents around the earth were obtained, we would scarcely expect that such results would be legitimately obtained in a few pages of verbal reasoning without the aid of mathematics. It is true that more recently a very small effect of that kind has been obtained, tending to produce a westward current in all latitudes, from which, by means of friction, the earth's rotation on its axis is supposed to be slightly changed, but this effect is of an order almost infinitely small in comparison with those under consideration, and not at all contemplated in the author's reasoning, referred to above.

WM. FERREL.

Washington, D.C., Nov. 7, 1874

#### Mud Banks on Malabar Coast

THE phenomenon of the "mud banks and of tracts of mud suspended in the sea" on certain parts of the Malabar coast, is not, as you suppose (vol. xi. p. 135), unexplained. The late Capt. Mitchell, curator of the Madras Museum, some years ago submitted a quantity of the mud to microscopic examination, and published the results in the *Madras Journal of Literature and Science* (I have not the work at hand, or I would give you volume and page). He found it to consist almost entirely of Diatomaceæ, of

which he detected and distinguished sixty-two species. In the paper in the *Madras Journal* Capt. Mitchell gives a list of the genera and a numerical list of the specific forms.

The causes that have determined this local development of Diatomaceæ remain for investigation. They appear sometimes to shift their place. Thus, a Dutch navigator (Stavorinus, I believe) described two such banks as existing to the south of Cochin in 1777, but these no longer exist.

Richmond, Surrey

HENRY F. BLANFORD

#### Ring Blackbird

EVERY morning a brown bird (apparently a female blackbird) feeds at my library window. She has a white spot on the breast, and a large white ring, in the exact position of that on a Barbary dove, not meeting under the chin. Is this an unusual variety? I see no mention of such a peculiarity in any of the books at hand, as Lewin, Bewick, Mudie, &c.

C. M. INGLEBY

Valentines, Ilford, Jan. 4

#### ON THE MORPHOLOGY OF CRYSTALS\*

PROFESSOR MASKELYNE, in introducing his subject, said that in the assembly-room of the Chemical Society he should have to treat of Crystallography as the Science of Chemical Morphology. To the chemist the crystallisation of a substance is a familiar marvel; so familiar, indeed, that he hardly sufficiently considers its importance in relation to his own science. For the physicist, on the other hand, the instinct with which the molecules of a substance obey the laws of a sublime geometry—sublime because simple and universal—is a theme the contemplation of which has guided him to some of the most subtle and almost metaphysical conceptions that he has formed regarding the constitution of matter, and has afforded him invaluable insight into the working of the laws that control the pulsations of heat and light and other manifestations of force. But, although the morphological relations of the crystal are the external expression of the more subtle physical properties which underlie them, he stated that the purpose of the lectures he was about to deliver would be confined to the consideration only of the former.

Placing a large and very perfect crystal of apophyllite from the Ghâts of India on the table, the lecturer pointed out that certain faces carrying peculiar striations were repeated four times; that again others of a triangular form, planted on the angles of the latter, were repeated eight times, and that these had a lustre of their own; while again a plane of octagonal form was repeated only once on the top and at the bottom of the crystal, and carried a peculiar roughened surface, which was seen to be made up of innumerable small square pyramids in parallel positions. He further showed that by turning the crystal round about an axis perpendicular to the last planes, the relative situations of the planes, as viewed from any point, came always to be the same at any revolution through a quarter of a circle. A group of faces repeated with similar properties was defined as a *form*, the crystal in question thus exhibiting three forms; the repeated faces of each form retaining the same general aspect so long as they were not moved round through an angle greater or less than 90°. Then taking crystals of quartz which presented the same *forms*, he pointed out that faces that corresponded to one another on the different crystals, and even on the same crystal, have very different relative magnitudes; and that, in fact, these magnitudes were controlled by no rigid geometrical law. On the other hand, the angles which measured the inclination of corresponding faces on each other were in every case identical; hence angular inclination, that is to say, the direction in space, not relative position, that is to say, precise mutual distance, in the faces, has to be recognised as a principle

\* Some notes of the Lectures delivered at the Chemical Society's rooms in Burlington House, on the Morphology of Crystals, by Prof. N. S. Maskelyne, F.R.S.

fundamental to crystallography. This may be expressed by saying that the angles of a crystal are symmetrically repeated.

The study of crystallography in its aspect as the science of chemical morphology thus resolves itself into the discovery of the laws which regulate the repetition of planes, the directions of which in space, and not their relative magnitudes, result from that geometrical instinct which guides the molecules of every individual substance as they become colligated into the symmetrical structure of a crystal.

The lecturer then went on to point out that the features of a crystal the symmetrical recurrence of which had to be studied were the *faces*, the *edges*, and the *quoins* (or solid angles); and he entered on a general geometrical review of the conditions under which faces in meeting produce an edge, or a quoin, or a series of edges or of quoins; and after showing the mode by which the angular inclination of two faces was measured, he dilated on one in particular among the various modes in which faces might meet, namely, that in which three or more faces intersect with each other in the same line or edge, or in edges parallel to the same line. For the crystallographer such groups of planes possess the highest significance; a group thus presenting parallel edges he denominates a *zone*, and it is clear that the direction of the line to which all the edges that can possibly be formed by the intersections of any and every pair of the planes belonging to the zone is indicated when we know the direction of any one of these edges. A considerable part of the earlier among the ensuing lectures will have to be devoted to the consideration of this subject of zones; and the development of the relations between the planes of a zone, under the restrictions imposed by a simple and beautiful law, will be found to involve fundamental principles regarding the symmetry which controls at once the morphological and the physical properties of the crystal in such a manner that all the systems, the symmetrical forms, and the general character of the optical, thermal, magnetic, electric and mechanical properties of the crystallised substance hang, as it were, suspended from that simple law by a chain, each link of which is a simple deduction from the link in the argument immediately above it.

Then taking a crystal of the mineral barytes, Prof. Maskelyne pointed out that certain planes upon it were repeated, some in parallel pairs, and others four times, but also in pairs that were parallel, while all of these planes presented the property already stated to be characteristic of a zone: their edges were parallel. Then, supposing a lapidary's wheel to have been passed through the middle of the crystal perpendicularly to all these edges, and therefore perpendicularly to the faces themselves, he proceeded to deal with the profile of the planes of the zone as they would be seen in such a section. He first defined such a section as the *plane of the zone*, or the *zone-plane*; and characterised it as a plane perpendicular to the edges of the zone. Then drawing a figure to represent this profile or *zone-plane*, he pointed out that two of the planes of the zone being perpendicular to each other, he might draw two lines through a point within the crystal and in the zone-plane parallel to the traces of those two planes, and therefore perpendicular to each other, and that now he could use these lines as axes, or as an artificial scaffolding, to which he could refer the traces of the other faces of the zone, and by the aid of which he might determine the relative directions of those faces.

The circumstance already established by the scrutiny of many crystals, namely, that the faces of the crystal might be drawn nearer or further from a point within the crystal indifferently, justified the lecturer in drawing the traces of two of the faces in the zone so as to intersect in the same point on one of the two axes thus chosen. They would thus intersect on the other axis two different

portions of that axis. Calling the former of these axes  $Z$  and the latter  $X$ , we may say that the ratio of the *intercept* by either of the two planes on the  $Z$  axis to the *intercept* on the  $X$  axis by the same plane is the tangent of the angle formed by the trace of the plane in question with that of the plane parallel to the axis of  $X$ , or the co-tangent of the angle it forms with the trace of the plane parallel to the axis  $Z$ . This tangent for the plane in question, which gave an angle of  $51^{\circ} 8'$  by measurement for the angle on the axis  $X$ , had a value  $1.2407$ . The other face of the zone, being represented by the line which met the axis of  $X$  at an angle of  $68^{\circ} 4'$ , would thus yield a corresponding tangent of  $2.4834$ . It will be seen, therefore, that the ratios of the intercepts for the two planes would be, for the first plane,

$$\text{the } X \text{ intercept} : \text{the } Z \text{ intercept} :: 1 : 1.2407$$

for the second plane,

$$\text{the } X \text{ intercept} : \text{the } Z \text{ intercept} :: 1 : 2.4834$$

If the first of these ratios be called that of  $a : c$ , the second will be that of  $a : 2c$ , i.e. of  $\frac{a}{2} : \frac{c}{1}$ . The co-tangents of the angles would of course yield similar ratios for the distances on the axes  $X$  and  $Z$  at which the two planes intersect with them: but the common intercept on the  $Z$  axis would in this case be unity. The ratios would be

$$\frac{X \text{ intercept}}{Z \text{ intercept}} \text{ for the first plane} = \frac{0.80594}{1} = \frac{a}{c}$$

$$\text{Ditto for the second plane} = \frac{0.40267}{1} = \frac{a}{2c}$$

A third plane in the zone treated in the same way would give an angle the tangent of which would lead to a ratio for the intercepts corresponding to  $\frac{a}{5} : \frac{c}{2}$ , and

if the same process were extended to all the planes in the zone, it would be found that all of them would yield, by the simple process of measuring their inclinations and taking the tangents of their angles on the plane represented by the axis  $X$ , values that may

be represented by the proportion  $\frac{a}{h} : \frac{c}{l}$ , where  $a$  and  $c$  are in the ratio above determined, and where  $h$  and  $l$  always are capable of representation by rational and generally, nay, almost always, by very small whole numbers. This law thus simply enunciated for the faces of a single zone, as referred to two axes parallel to two faces of the zone here taken as perpendicular to each other, will be found, when the faces of the crystal are referred to three axes instead of two, not in the same plane, and also when they are inclined to one another at other angles than right angles, still to control the inclinations of the faces of the crystal, provided only that the axes  $XYZ$  thus taken be lines of crystallographic significance, such as lines parallel to edges formed by faces of the crystal; while the ratios  $a : b : c$  represent the intercepts on those axes taken in the order  $XYZ$  of a fourth face of the crystal and are the numerators, while letters such as  $hkl$  stand for the numerical denominators in the fractions that represent the ratios of the intercepts of any other fifth plane of the crystal. Any three numbers in the ratios  $a : b : c$  represent the intercepts on the axes of the fourth or standard plane, and are called the *parameters* of the crystal; one parameter in particular being generally taken as unity. The numbers by which the parameters have to be divided in order to assign the ratios of the intercepts to any fifth plane of the system, namely, the simplest numbers expressive of the ratios  $h : k : l$ , are called the *indices* of that plane; and when these indices are united into what is termed the *symbol* of the plane, by being written in brackets as  $(hkl)$ ,  $(321)$ , &c., one understands by this that

$\frac{a}{h} : \frac{b}{k} : \frac{c}{l}$  represent the ratios of the intercepts of the plane ( $h k l$ ), and  $\frac{a}{3} : \frac{b}{2} : \frac{c}{1}$  those of the plane ( $3 2 1$ ). Where either of these values  $h, k,$  or  $l$  becomes zero, this would represent an intercept indefinitely great upon the axis to which it refers, since the algebraic value of a quantity of the form  $\frac{m}{0}$  is infinity. Referring

again to the original zone on the crystal of barytes, we see that the face, the trace of which on the zone plane was taken for the axis of  $Z$ , will nowhere intersect with that axis, so that its index for the axis of  $Z$  becomes 0, and similarly for the plane parallel to the axis  $X$ . In like manner if an axis  $Y$  perpendicular to the zone plane representing the profile of the zone of barytes had been taken for a second axis, all the planes of that barytes zone would have been parallel to that axis  $Y$ , which is in fact its *zone axis*, being parallel to the edges of the zone, and the index with respect to that axis would for each plane of the zone have been 0. Thus, taking our indices in the order corresponding to that of the axes  $X Y Z$ , we can now say that the plane, the trace of which gave us our axis of  $Z$ , would have for its symbol ( $u 0 0$ ), where  $u$  was any whole number, or rather, since we may divide the whole symbol by  $u$  without altering the ratio, (100). So, the plane the trace of which gave us the direction for the axis of  $X$  would be (001); the standard plane that gave the parameters  $a$  and  $c$ , having for its intercepts the values  $\frac{a}{1} \cdot \frac{c}{1}$ , would be represented by the symbol (101), while the other two planes would receive the symbols (201) and (502).

Since all planes on a crystal must intersect if continued far enough with all three or with only two, or finally with only one of the axes, they may be considered as falling into one or other of three groups: such, namely, as have three whole numbers in their symbol; such as have one zero in their symbol (the zero corresponding to the axis with which they do not intersect); and, such, thirdly, as have two zeros with unity for their indices.

Passing from a system with rectangular axes, the lecturer next considered the general case of an axial system in which the axes might be oblique to each other. In pointing out that the three planes which contain these axes, namely, the planes  $X Y, Y Z, Z X$ , divided the space around the point in which they and the axes intersected into eight divisions or octants, he proceeded to designate the position of a point situate anywhere in space by the Cartesian method of co-ordinates. The point 0 of intersection of the axes being called the origin, and positions to the right, above, or in front of it, being considered as positive; those to the left, to the rear, and below it, as negative, it becomes possible, by means of lines parallel to the axes projected from the point, to determine its position in either octant. Then taking two planes in a zone which intersected with all three of the axes, such as two planes (111) and (321), the lecturer showed, by a representation in a model, how the edge in which these two planes intersected could have its direction determined by making it parallel to the diagonal of a parallelepiped the sides of which would represent the co-ordinates of any point in that line, in the ratios of  $u a : v b : w c$ , where  $u, v,$  and  $w$  represented values which the lecturer proceeded to deduce from the symbols of the faces. For this purpose he represented the planes by two equations or expressions involving the ratios of the co-ordinates of any point in the plane, in terms of the parameters of the crystals and the indices of the planes.

Then, by a familiar algebraic method, he obtained an expression for the relations between the co-ordinates for any point in the line in which the planes intersected. The expression thus obtained gave a symbol for the edge in the form of the *determinant* of the indices of the two

planes: thus a symbol [ $u v w$ ], included in square braces, representing the edge formed by the planes ( $e f g$ ) and ( $h k l$ ), had for the values of its indices—

$$\begin{aligned} U &= f l - g k \\ V &= g h - e l \\ W &= e k - f h \end{aligned}$$

and the lecturer proceeded to show that any third plane with the indices  $p q r$  belonging to the zone [ $u v w$ ] must fulfil the condition—

$$pU + qV + rW = 0$$

and furthermore, that if two zones had a plane in common, the symbol of that plane is found by taking the determinant of the symbols of the zones.

The next subject treated of had reference to the various means which geometry offers for a more convenient treatment and representation of the different zones of a crystal, than that of making an elaborate drawing of its edges. Of these, the method of referring the planes of a system to a sphere by means of their normals was shown to possess great simplicity. A sphere being conceived as described around the point, or *origin*, in which the axes cross one another as a centre, lines drawn from that point perpendicular to each plane of the crystal—the *normals* to these planes—are continued till they penetrate the surface of the sphere in points that will be called the *poles* of the planes, the symbol for a pole being identical with that for the plane to which it belongs. The poles of a zone of planes will thus be distributed along the arc of a great circle of the sphere, its *zone circle*. Hence the discussion of the inclinations of the planes of a crystal, and so, many of the chief problems of crystallography, becomes reduced to their treatment by spherical trigonometry; and what has further rendered this mode of considering the relations of the planes of a crystal especially advantageous has been the means which the principles of the projection of the sphere afford us of graphically representing within the circumference of a circle the poles corresponding to all the faces, however numerous, that any single crystal or that all the different crystals of a substance may present, while the symmetry which they obey in their distribution is seen at a glance. The stereographic projection employed in Prof. Miller's system for this purpose affords by its simplicity, its ready application, and the important geometrical principles which it possesses, by far the most practical, and with a little experience in the student, much the most intelligible representation of even the most complex forms of crystallography.

The characteristics of the stereographic projection were exhibited in a small working model, in which it was shown that the eye, supposed to be placed at a point on the sphere of projection, would see the arcs of circles on the opposite hemisphere as though projected on a plane screen passing through the centre of the sphere and intersecting with its surface in a great circle, the *circle of projection*, at the pole of which the eye was situate; such arcs of circles on the sphere were shown to be projected as arcs that themselves were circular, and the method of finding the centres for these projected arcs, and again the mode of determining the value of an arc on the projected circle by drawing lines from a projected pole of that circle to the circle of projection, so as to intercept the required arc upon the latter circle, were illustrated in the case of arcs upon the model.

The next subject taken up by the lecturer was in the form of a digression in which he treated of the relations of the parts into which a line was divided by four points, two of which might be supposed to be stationary, while the two others assume different positions on the line. First the harmonic and then the anharmonic division of such a line was discussed; and from this, the lecturer passed to the consideration of the harmonic and the anharmonic division of an angle, contained by two and divided by two other lines; and he showed, firstly, that when two lines out of four passing through the same



point are perpendicular, and one of these bisects the angle formed by the remaining two lines, the sines of the angles taken in the proper order are in the harmonic ratio. Another point illustrated was that a sheaf of four lines presents the same anharmonic ratios of their sines as does a sheaf of four lines severally perpendicular to them. Reverting to the subject of the traces of the faces of a zone on their own zone plane, it was now seen that we can discuss the subject of relations of any four planes in the zone by considering those of their normals the angles between which are measured on a great circle of the sphere. But it remains to obtain an expression that shall connect these angles with the symbols of the poles or faces of the zone. Such an expression obtained by Prof. Miller in the first case involves a relation of the simplest kind. In short, the anharmonic ratio of four planes is the ratio which we obtain directly from the determinants of the symbols for the four planes. Since, however, the symbols for a zone as obtained from the symbols of different pairs of faces of the zone may, and generally do, differ by a common factor, it is advisable to put the expression for the anharmonic ratios of four tautozonal planes under the form of a convenient symbol given them by V. von Lang, viz., for the four planes  $PQR S$  :—

$$\left[ \frac{PQ}{QR} \right] : \left[ \frac{PS}{SR} \right] = \frac{\sin PQ}{\sin(PR-PQ)} : \frac{\sin PS}{\sin(PR-PS)} = \frac{m}{n}$$

where the letters on the left side of the expression stand for the symbols of the planes of which the determinants are to be taken. This very important expression offers the means of determining one unknown symbol or one unknown angle among those belonging to the four planes; another result that flows from it is the necessity for the anharmonic ratios of four planes in the zone, i.e. the magnitudes  $m$  and  $n$ , being always rational if the planes belong to a crystal. And this is another and more general way of stating the fundamental crystallographic law, that of the rationality of indices.

Prof. Maskelyne next proceeded to discuss some of the further results deducible from this great law. Firstly, since the harmonic ratio of four planes brings those planes under the requisite condition of rationality, we can say of any zone in which two of the planes are perpendicular to each other, that for any third plane of the zone inclined on one of them at an angle  $\phi$ , a fourth plane may also exist as a possible plane of the zone, also inclined on the first plane at the angle  $\phi$ ; and further, the professor went on to state that if we ask the question what are the conditions for three consecutive planes in a crystal zone to include the same angle  $\phi$ , we find for answer that only in those cases is this possible where  $\cos. \phi$  is rational, and that this is only so where  $\phi$  possesses one of the values  $90^\circ$ ,  $60^\circ$ ,  $45^\circ$ , and  $30^\circ$ .

After a review of the results thus far obtained, the professor entered upon the subject of symmetry, and defining the different varieties of geometrical symmetry; such as, firstly, the symmetry of a plane figure to a centre of symmetry, to one or to several lines of symmetry, or to a pivot of symmetry; and secondly, that of a solid figure to a centre of symmetry, to one or to several planes of symmetry, and to one or to several axes of symmetry; he defined certain terms which would be found useful in the discussion of the symmetry of crystals. Thus, a plane figure was *cutly-symmetrically* divided by a single line of symmetry or *ortho-symmetrically* divided by two lines of symmetry perpendicular to each other; while an axis of, for instance, hexagonal symmetry became one of di-hexagonal symmetry, where each repeated element of form is itself doubled, as by reflection, on a plane of symmetry.

In applying the principles of geometrical symmetry to crystals, it was shown that the best and simplest method was that of dealing with the distribution of their poles on the sphere of projection.

The condition requisite for a single plane of symmetry to exist upon a crystal was then shown to be that this plane should be at once a zone plane and a possible face of the crystal. On the other hand, for a crystal to be symmetrical to a centre, no particular condition was requisite, since the direction and not the requisite position of a crystal plane has been seen to be the important point regarding it, while again every plane passing through the origin may be represented by the symbol of either of its poles indifferently. Now, an axial system as previously defined involves five variable quantities; namely, the three angles between the axes :

$$\begin{aligned} \xi, & \text{ the angle } YZ \\ \eta, & \text{ the angle } ZX \\ \zeta, & \text{ the angle } XY \end{aligned}$$

and the two ratios involved in the parameters, namely,  $\frac{a}{b}$  and  $\frac{c}{b}$ .

Hence, for a crystal to be centro-symmetrical, all these five quantities may vary from one substance to another. If, however, the crystal system be divided symmetrically by a plane, two of these axial elements are absorbed in satisfying the two requisite conditions of that plane being at once a crystal face and a zone-plane.

A crystal system that is simply centro-symmetrical presents the kind of symmetry characteristic of what is called the Anorthic system of crystallography; a crystal that obeys the principle of symmetry to a single plane belongs to the Oblique or Clinorhombic system.

(To be continued.)

## TWO REMARKABLE STONE IMPLEMENTS FROM THE UNITED STATES

THE similarity of stone implements, both modern and prehistoric, that obtains throughout the world, has been commented upon so frequently as scarcely to need further illustration. Within a few days, however, I have found two forms of arrow and javelin points that are so unusual in their shapes, and otherwise of interest,

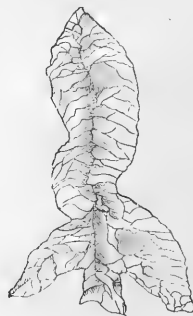

FIG. 1.—(Natural size.)

that I believe drawings of the two, and a brief note concerning them, will be welcomed by archaeologists.

Fig. 1 represents a "flame-shaped" arrow-point, as this shape has been well called by Mr. E. B. Tylor (*vide* "Anahuac," by E. B. Tylor, p. 96, Fig. 1). Although I have collected fully ten thousand specimens of "Indian relics" from the immediate neighbourhood of Trenton, New Jersey, U.S.A., of which a very large proportion were spear and arrow heads, I have not been able before to duplicate this form, or to find any unmistakable trace of it in the bushels of fragments that here cover the ground in some places. This arrow-head, accompanied by the javelin (Fig. 2) and several of the leaf-shaped

pattern, was found in a fresh-water shell-heap on the bank of Watson's Creek, Mercer Co., N. J. The peculiar interest attaching to this "flame-shaped" specimen is, I consider, two-fold. First, the form is one hitherto known only as Mexican—at least, in the works on Stone Implements of which I have knowledge there is no illustration of a similar specimen; and secondly, while possibly this specimen may have been brought from Mexico, through the system of barter so extensively carried on by the aborigines—I have found fragments of obsidian arrow-points in New Jersey, the material of which, if not the finished weapons, must have come from Mexico—it seems more probable that it was fashioned in this neighbourhood, and being found, it may be, of an unde-

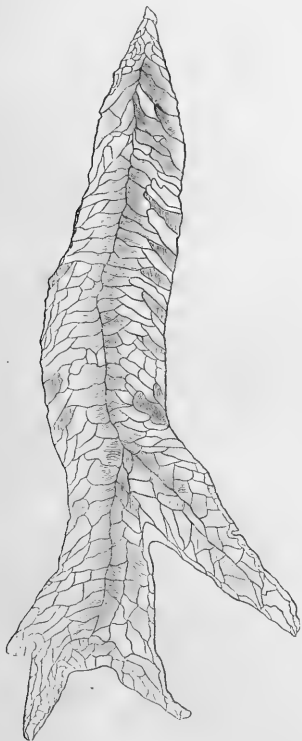

FIG. 2.—(Natural size.)

sirable shape (Mr. Tylor does not state if this pattern was common or rare in Mexico), was not adopted as one of the many forms given to this class of weapons. If my supposition is correct, then the specimen is a good example of the production of a similar style of weapons in distant quarters of the globe.

The mineral, both of this specimen and that which is represented by Fig. 2, is a dull bluish-white hornstone, very similar in general appearance to the European flint. The smaller specimen measures two and a quarter inches in length. It is noticeably thin, and remarkable for the small size and irregular outlines of the flakes. This irregular flaking off of the mineral under the blows of the hammer-stones is due to the "impure" character of the mineral, there being thread-like veins of brittle

silex (?) enclosing minute pebbles extending through the mass in every direction, and these appear to have checked the flakes and caused their jagged irregular outlines.

Fig. 2 represents a remarkable javelin head made of the same material as the preceding, and having, but in a less degree, the "flame-shape" of the smaller specimen. The character of the workmanship indicates, I think, that the same aborigine chipped them both. Like the other, this spear-head is very thin and "irregularly" flaked. In the shell-heap in which these were found, as far as we have examined it, there was nothing else that differed from the ordinary "finds" and contents of aboriginal graves, being simply leaf-shaped arrow-heads, grooved stone axes, a corn-crusher and basin ("Querns," *vide* Evans' "Stone Implements of G. B.," p. 233), and a polished celt.

CHAS. C. ABBOTT  
Trenton, New Jersey, U.S.

#### PROTECTION FOR INVENTIONS

WE stated in our leading article of the 24th ult. on this subject, that in the course of the discussion at the Society of Arts, Col. Strange had mentioned that the Patent Commissioners requested the Royal Society some time ago to nominate one of three eminent men of science who should perform the herculean task of infusing scientific order into the Patent Office, but without salary.

The Society of Arts, in their journal of the 25th ult., have very properly published correspondence which fully establishes the correctness of a statement which otherwise might well be thought incredible. The subject of niggardliness to scientific men is so important, not merely to the men themselves, but more still to the progress of knowledge, and therefore to the interests of the whole community, that we feel bound to republish this correspondence. We must, of course, regret to animadvert on the acts of the late Lord Romilly, who is no longer amongst us to justify them; but the public duty must still be performed, and as his lordship wrote as the spokesman of his colleagues, they can at any rate defend, if they can, what at present seems indefensible.

In Lord Romilly's letter the proposed duties of these unpaid men of science are enumerated: they are to "superintend the general management of the Patent Office, to see that the indexes and abstracts of the specifications are made accurate and complete, and to redress the other defects complained of."

We here see precisely what sort of work four highly salaried lawyers considered men as eminent in science as they in law might with perfect justice be expected to execute for nothing, namely, a combination of hard routine drudgery with the most delicate discrimination in questions extending over the whole range of scientific knowledge. It is true that their labours were to be lightened by the invaluable privilege of "acting in conjunction with the Lord Chancellor and the Master of the Rolls, and of referring to them" whenever the occasion of too tough a problem might require it. In plain English, the men of science were to do all the work of the Patent Office gratuitously, but in the name of these highly-paid lawyers, who notoriously do none of it, but who would thus pocket both the credit and the substantial reward.

If this had been an isolated example of the assessment of scientific work in England, we should hardly have cared to draw attention to it for the mere sake of denouncing exceptional narrowness of view and selfish injustice. It is because the example is typical that we assist Col. Strange and the Society of Arts in exposing it. The best proof of the prevalence of the same spirit is afforded us by some evidence volunteered by the Marquis of Salisbury before the Duke of Devonshire's Science Commission. His lordship observed that "Government departments have got an idea into their heads—I do not know why—that scientific opinions differ in this from medical

and legal opinions, that they have a right to have them gratuitously. I have never been able to understand on what grounds that theory rests; and my belief is, that if you would assimilate scientific knowledge to medical and legal knowledge in that respect, you could always get, for a proper remuneration, the very best scientific opinion that the country is able to furnish. You cannot expect that you should be able to make upon a man, every moment of whose time is occupied, a demand involving his time for hours or days of research, if you are not prepared to behave to him as you would to a lawyer in a similar case."

There is no reason to suppose that, though these observations reflect with severity upon the Patent Commissioners' proposal, Lord Salisbury had that case in view when he made them. He was no doubt giving the result of his wide experience as a statesman and departmental chief, and it is a comfort to know that in the present Cabinet there is at least one man competent to assign its true value to scientific work, and bold enough to insist that that value shall be given. It will be perceived that Lord Salisbury hints that the departments are not, and cannot be expected to be, supplied with "the best scientific opinion," because it is not properly paid for. He therefore urges liberality to men of science, as we have always done, strictly on the ground of public policy. An instance in point recently came to our knowledge where a department asked one of our most eminent physicists for an opinion on a meteorological question, but the correspondence was abruptly closed on his venturing to inquire what would be his remuneration for preparing a laborious and difficult report.

Foreign nations are now teaching us that it is time short-sighted parsimony like this came to an end, and that the sooner men in authority are "prepared," as the Patent Commissioners phrase it, to pay handsomely for the most fruitful work of which man is capable, the better for the country.

It must not be overlooked that at the time this preposterous proposal was made by the Patent Commissioners two of their own number were the recipients of 5,000*l.* or 6,000*l.* a year, paid out of the Patent fees, for which they rendered, and could render, for want of the requisite knowledge, absolutely no service to the Patent system, and that the surplus income of the office was about 90,000*l.* per annum.

The following is a copy of the correspondence referred to by Col. Stange in his remarks during the discussion, as having taken place on the subject of appointing unpaid Commissioners of Patents:—

(*Copy of the Memorial.*)

To the Right Hon. the Lord Romilly, Master of the Rolls.

My Lord,—The great use of patents is to make known the inventions, processes, and secrets of others. It is therefore highly important that the mass of information accumulated at the Patent Office should be made available, so as to make known as far as possible all inventions and modes of manufacture for the benefit of the country. The advantage of so doing would be immense, and would help to keep the manufactures of this country in advance of others. Action in this direction on the part of the authorities has been prayed for in every memorial that has been presented.

One of the first memorials was presented by the Institution of Mechanical Engineers, with Mr. Robert Stephenson as president at its head. This was presented in 1853 to the Right Honourable Frederick Lord Chelmsford, Lord High Chancellor of Great Britain, the Right Honourable Sir John Romilly, Master of the Rolls, Sir Fitzroy Kelly, her Majesty's Attorney-General, and Sir Hugh McCalmont Cairns, her Majesty's Solicitor-General; and prayed for greater facilities being given to persons making inquiries in any branch of knowledge at the Patent Office.

The second memorial in 1862 was presented to the Right Honourable Sir John Romilly. It prayed amongst other things for "a building as an office for patents, including in it a complete library, a commodious reading-room, and suitable offices

for a proper staff of clerks and others to prepare well-digested and numerous abstracts and abridgments of inventions and processes, made public either by the specifications of patents or otherwise, and whether English or foreign."

A third memorial was presented to Sir John Romilly in 1864. It prayed not only that the efficiency of the office should be increased, but called the attention of the Commissioners to recent reductions in the staff and its disorganised state; which staff was "utterly inadequate to satisfy the requirements of persons seeking information among the very numerous works contained there." The memorialists went on to state that "they had entertained the hope that, so far from a reduction being made, there would have been an increase ordered to such an extent as would have enabled the abridgments of the specifications in the various branches of art (which abridgments were commenced about seven years ago) to be pushed vigorously forward, so as to complete the abstracting of the whole of the original specifications, and to keep up those abstracts from year to year as new matter is furnished. Your memorialists feel it is hardly possible to overrate the advantages to be derived by the public from a complete and intelligent system of abstracts; and they venture to urge upon the consideration of the Commissioners the necessity of at once providing a sufficient number of qualified persons (to be under the entire control of the scientific officer appointed by the Commissioners to superintend the specifications) to assist that officer in preparing such abstracts, and also to collect and epitomise scientific information generally."

The president and members of the Institution of Mechanical Engineers addressed a memorial in 1864 to the Right Honourable Lord Westbury, then Lord Chancellor, bringing under his lordship's notice the fact "that very great loss and delay are occasioned to manufacturers, inventors, and others, by the want of a complete classification and the prompt indexing of all inventions, whether patented or not, foreign as well as English. Such a systematic arrangement as is needed is quite within the compass of an efficient staff of officers possessed of technical knowledge, and could be at once proceeded with; the state of inventions could then be ascertained, and the common case of several persons patenting the same thing would be avoided."

In 1864 a Select Committee of the House of Commons inquired at great length into the working of the Patent Office; and reported, in accordance with the general tenor of the evidence, that much more was required to be done at the Patent Office to render it efficient; that more attendants were required, and "that the want of increased accommodation was so much felt as to prejudice the due administration of the Patent-law" (paragraphs 3 and 4 of report; answers 10 to 13, 18 to 21, 658 to 662, 667, 817, 863, 1038, and 1039 of evidence).

We merely allude to the opinions expressed by the Select Committee of the House of Commons, scientific men, manufacturers, engineers, and inventors, as the various memorials and other documents are in the possession of the Commissioners of Patents; but we would further mention that the various Commissioners of Patents have from the year 1858 reported from time to time to the Lords of the Treasury that great improvements were wanted, and a good building urgently required for the purposes of the Patent Office.

In conclusion we beg to state that it is our decided opinion, and that of many of those who have signed various memorials, that it would conduce greatly to the progress of manufactures and the advancement of commerce, if the large stock of knowledge of inventions and processes, both patented and open, stored at the Patent Office, were made available to the manufacturers and the public generally; and this your petitioners believe would best be compassed if her Majesty were graciously pleased to appoint that "other person as Commissioner of Patents," as contemplated by the Patent-law Amendment Act of 1852, and if the staff at the Patent Office were augmented by the addition of a sufficient number of persons, possessed of good technical knowledge, and well able to abstract all specifications as they came in daily, so that they might at once be entered into an efficient Subject-matter Index, which would give a true indication of what was in the specifications. In addition to this of course the large number of specifications already at the office would require to be abstracted and entered in a similar manner in a new edition of subject-matter indexes, that would really indicate what was contained in each specification, which the present indexes do not. Further, we beg to urge that similar subject-matter indexes be formed of all inventions and processes comprised in the very numerous indexes and tables of contents of the scientific books contained in the excellent scientific and technical library

of the Patent Office, so that any person using due diligence might easily learn with tolerable certainty whether an invention were new or old, which is not now the case.

We beg to append a sample page of such two subject-matter indexes as we would submit are urgently required. It is almost superfluous to mention that there are now several hundred thousands of pounds accumulated surplus, and an annual surplus of about sixty thousand pounds, contributed by the very class of persons who would benefit by such improved indexes.

L. L. DILLWYN, M.P.  
 RICHARD BAGGALLAY, M.P.  
 CHARLES FOX, Mem. Inst. C.E.  
 CHARLES HUTTON GREGORY, President Inst. C.E.  
 EDWARD WOODS, Mem. Inst. C.E.  
 C. WILLIAM SIEMENS, Mem. Inst. C.E., F.R.S.  
 ROBERT MALLET, Mem. Inst. C.E., F.R.S.  
 FREDERICK J. BRAMWELL, Mem. Inst. C.E. Council.  
 EDWARD A. COWPER, Mem. Inst. C.E.

20th March, 1868.

(Copy of Reply of the Master of the Rolls to Mr. Dillwyn.)

Rolls, 31st March, 1868.

Sir,—I transmitted to the Lord Chancellor the memorial presented to me on the 20th March instant by yourself and the gentlemen who accompanied you, relative to the present state of the Patent Office, together with my views on the subject; and we have since considered the matter in consultation together.

The result of this is that we are prepared to recommend to her Majesty's Government that three gentlemen should be appointed to act as Commissioners of Patents together with the Lord Chancellor and the Master of the Rolls for the time being—one to represent mechanical science, another to represent chemical science, and a third to represent the subjects more usually and more especially comprised in the term "Natural Philosophy." We should propose that the gentlemen to be recommended to her Majesty for this purpose should be, as regards the first, from gentlemen to be nominated by the Society of Mechanical Engineers; as regards the second, from gentlemen to be nominated by the Chemical Society; and as regards the third, from gentlemen to be nominated by the Council of the Royal Society. But we are not prepared to recommend that any salary should be attached to the services of these gentlemen. We trust and believe that gentlemen fully competent for the purpose may be found who have sufficient leisure, and who, from their love of science and their desire to disseminate more widely the discoveries made in these branches of science, would be willing to give their services without remuneration, and to superintend the general management of the Patent Office, to see that the indexes and abstracts of the specifications are made accurate and complete, and to redress the other defects complained of in your memorial, acting in all these respects in conjunction with the Lord Chancellor and the Master of the Rolls, to whom they would refer whenever the occasion might require it.

I think it, however, desirable to repeat that, on fully considering the subject, both the Lord Chancellor and myself have arrived at the same conclusion, that it would be inexpedient to create either one or more salaried officers for this purpose; and to say that we should both, if applied to, recommend her Majesty's Government not to accede to that part of the views of the gentlemen who composed the deputation, which had relation to the creation of paid officers.

KOMILLY.

L. L. Dillwyn, Esq., M.P.

#### FRANCIS KIERNAN, F.R.S.

WE have to record the death, on Dec. 31st last, of Mr. Francis Kiernan, whose discoveries in connection with the structure of and circulation through the liver, published in the Philosophical Transactions of the Royal Society, and separately in a work entitled "Anatomical Researches on the Structure of the Liver," are so well known to all physiologists and histologists.

Mr. Kiernan was born in Ireland on October 2nd, 1800. His father was a member of the medical profession, who came to this country during his son's younger days. The son was educated at the Roman Catholic College at Ware, in Hertfordshire, and received his medical training at St. Bartholomew's Hospital, where, as a student, he gave

signs of marked ability, devoting all his energies to the study of anatomy. In 1825 he obtained the membership of the College of Surgeons, and the Fellowship in 1843. In 1834 he was elected a Fellow of the Royal Society, subsequently receiving the Copley Medal.

Mr. Kiernan was amongst those most actively engaged in the establishment of the University of London, of the Senate of which institution, on its incorporation in 1837, he became a member, and subsequently a frequent examiner in his special subjects. He was never married. In 1865 he was seized with a paralytic stroke, from the effects of which he never fully recovered.

The investigations of Mr. Kiernan on the liver, together with those of Mr. Bowman on the kidney, will be always looked back to by biologists as the first-fruits of the introduction to natural science of the microscope in its modern form. Unlike many such productions, however, they have both fully stood the test of time.

#### THE RECENT THAW

THE thaw of January 1, 1875, happened almost simultaneously in Paris and London, and the phenomenon having been observed in both cities, it is possible to come to a definite conclusion concerning many similar occurrences.

The exact hour of the change in Paris may be stated to have been nine o'clock in the evening. If we suppose it was four o'clock in London, we see that five hours were a sufficient space of time for the gale to run the distance between both cities—about 300 miles.

Telegraphic warnings had been sent from London to the Paris Observatory, but were of little practical use, for want of proper means to disseminate the intelligence; otherwise, many inconveniences which were experienced by the Parisians, surprised by the falling of sleety snow, would have been avoided.

This remarkable occurrence may be referred to as affording strong evidence in favour of extending and popularising in both countries the use of weather telegrams. But I think it may be useful to try to draw from these circumstances some other conclusions.

In January 1871 I inquired of M. Buys Ballot, now the president of the Utrecht Meteorological Office, if he could tell me how to foresee if winds were likely to take a favourable course for ballooning from Lille to besieged Paris. I was told by the learned meteorologist to look at the upper clouds, as any real change must of necessity take place in the upper strata of the atmosphere, and descend gradually to the earth.

Unfortunately these upper clouds were for days and days running from the south, and the opportunity of trying an ascent was lost. Before the sudden thaw of the 24th of December, as well as before the 1st of January, I saw other clouds taking distinctly the same northern course. It seemed to me that the motion of the upper strata was communicated gradually to the air in closer proximity to the earth, and that the meteorological revolution of the 1st of January was preceded by a great change produced in higher regions through some unknown cause.

My conclusion seems to me to be supported by the fact that the air was obscured by vapours before the thaw actually took place. The sun lost apparently almost all his warming power, as the difference between *minima* and *maxima* read at the Observatory of Paris at the end of the cold periods amounted to a very few centesimal degrees—three or four only; clear air and hot sun being, if the theory is supported by facts, an evidence that cold weather is to last for a long period. It seems that the upper current is produced by cold and dry air coming from the north and pushed southwards.

It would be interesting to submit the theory to the test

of systematic ascents, in order to inquire into the condition of the upper winds, and to measure their deflection or velocity, or their dimensions either in vertical or in horizontal directions.

Some of the readers of NATURE may possibly feel inclined to help me in working out these suggestions practically, or at least to ascertain if they are justified by facts as far as can be ascertained without travelling in the air.

W. DE FONVIELLE

### EARTHQUAKES IN THE PHILIPPINE ISLANDS

A CORRESPONDENCE from Manila, dated Oct. 17-18, gives the following notice of earthquakes occurring there and in the neighbourhood on Oct. 10, which may be of interest to some readers of NATURE:—

#### Manila.

10.12 A.M.—Hard shock; duration about 1 min.; general direction from E.—W., but moving from S.E.—N.W. to N.E.—S.W.

10.15 A.M.—E. 25° N.—W. 25° S.; duration 5 sec.; rotation from E.—N.

10.20 A.M. till 10.15 P.M.—Thirty-seven other light shocks, *i.e.* in the whole thirty-nine shocks in twelve hours.

The interval of these shocks became at last greater and greater in the following order:—

10.20 A.M.	11.20 A.M.	12.2 P.M.	12.55 P.M.
10.25 "	11.23 "	12.19 "	1.9 "
10.30 "	11.26 "	12.20 "	1.52 "
10.40 "	11.31 "	12.22 "	2.40 "
10.43 "	11.34 "	12.24 "	4.2 "
10.46 "	11.41 "	12.31 "	6.25 "
10.50 "	11.44 "	12.42 "	8.15 "
10.51 "	11.46 "	12.45 "	9.15 "
11.12 "	11.58 "	12.50 "	10.15 "
11.15 "			

#### Dulacan.

10.8 A.M.—Hard shock.

10.11 A.M. till 1 P.M.—Lighter shocks.

#### Pampanga.

10.13 A.M.—N.W.—S.E. Hard shock; duration 50 sec.

10.21 A.M.—Duration 20 sec.

12.30 P.M.—Light shock.

#### Pangasinan.

10.25 A.M.—S.E.—N.W. Duration 26 sec; light shock.

#### Cavite.

10.11 A.M.—Light shock.

10.45 A.M.—Light shock.

12.13 P.M.—Light shock.

#### [Batangas.

10.2 A.M.—E.—W. Two shocks, of 10 sec. and 7 sec. duration.

#### Laguna.

Light shock; 2 sec. duration.

Royal Natural Hist. Museum, Dresden, Dec. 25

A. B. MEYER

### THE TRANSIT OF VENUS

THE following telegrams have been received during the past week:—

From Prof. Peters, *vid* Wellington, New Zealand:—

"Transit observation great success first contact; photographs, 237."

"New York, Dec. 31.—Intelligence has been received here from Honolulu, dated the 12th inst., respecting the

observations of the Transit of Venus at that station. The atmospheric conditions were favourable for the observations; 150 measures of cusps and limbs and 60 photographs were obtained. A totally unexpected appearance was presented at the internal contact. The disc of the planet became visible as an entire circle some minutes before contact, and from then to the complete establishment no definite or sudden phase was observed. There was no black drop after the internal contact. Twenty out of sixty photographs came out blurred. Valuable results, however, were obtained. The first external contact occurred at 3h. 7m., and the first internal contact at two minutes later than the *British Nautical Almanack* stated. The revelation of the complete circle of the planet occurred before the actual internal contact, owing to the effulgence of the corona, the sun illuminating the whole surface of Venus before the complete immersion."

In connection with the news from Honolulu, an article in the *Times* of Tuesday says:—"The most remarkable part about it is that the observers evidently regarded as an 'unexpected appearance' a phenomenon similar to one observed and recorded in the former transits of 1761 and 1769. In the observations of Chappe d'Aueroche in the latter year, recorded by Cassini, a drawing is actually given of the horns of Venus visible beyond the edge of the sun, and it seems probable from the text that the planet was actually seen on the sun's chromosphere at the moment of egress."

Indeed, this phenomenon need not have caused any surprise if the conditions had been previously clearly understood. In reference to this point, some statements from the *Daily News* Thebes correspondent (Dec. 9) are worth quoting. In speaking of the commencement of the phenomenon the correspondent says Venus "appeared anything but a promising subject for the purpose at first. She seemed literally to dance about the face of the sun, and her limb was jagged like a saw. They both appeared elliptical in an almost extraordinary degree, owing of course to refraction, and they did not lose it entirely till they were at least 7° from the horizon. Gradually the limbs of both got more and more defined, till Venus looked like a small black pea resting on a luminous disc. The sun, however, still remained somewhat troublesome, particularly to the photographers, and it was not till just before internal contact that he was really steady. The atmosphere of Venus was distinctly seen at certain periods. It showed as a pale white circle round part of her edge, and was totally different to the brilliant sunlight. The general remark was that it reminded us of moonlight. This caused a certain difficulty in estimating the true time of contacts, and perhaps any small discrepancy in observation may be accounted for by this phenomenon. . . . There is one curious coincidence to note, and that is, that no one seemed to have observed the black drop which has been so much talked about; a faint haze was seen, and a few jets of black springing out from each side of the point of contact, but nothing more. Neither in the photographs did it show, which perhaps might have been expected. Certainly, the weather could not have been more favourable just at the critical time, though, curiously enough, immediately after, a haze came on, which would seriously have affected the results. Need I say that we are all thankful the observation has passed off so well, and if only the other stations to which expeditions have been sent are equally fortunate, the sun's distance ought to be definitely settled. I fully expect that the appearance of the faint line will give rise to a long discussion in the astronomical world. It will be very curious to note what other stations saw. At all events one thing is certain, and that is that our atmosphere must have been very clear, and also that of Venus; clouds in the planet must have intercepted the sunlight, and have prevented the formation of the luminous ring, or rather partial ring. At one time the whole planet, when

it had half passed over the limb of the sun, was visible, reminding one of the dark part of the new moon on a clear night. I may say that the whole appearance of internal contact was quite unexpected, and the absence of the black drop puzzled every observer. External contact was observed, I hear, almost simultaneously by all observers, a point of the utmost importance when the degree of ellipticity of the planet has been determined from measurements of her diameter."

### NOTES

THE Germans, we are glad to see, have finally decided to send out a second expedition to the east coast of Greenland. It is to consist of two steam-vessels, of 300 tons burden, each manned by thirty men; one to explore Greenland, while the other advances to the north pole. The estimated cost is about 50,000*l.* sterling, and the expedition is to leave in June 1875 or June 1876, according as the money can be got together. There is no hint that the German Government is to lend assistance, though we hope it will do something, after such a good example has been set by our own Government. It would be a splendid and healthy outlet for national rivalry to have these two expeditions start this year, each doing its best to win the Arctic campaign, and striving to be the first to unfurl its particular national flag over the long-fought-for goal. At all events, during the next two or three years we ought to hear of some fine conquests having been made in the far north. The preparations for our own expedition are steadily progressing. Commander Markham, R.N., arrived on Tuesday at Portsmouth.

ONE of the principal articles in this month's *Geographical Magazine* is on Lieut. Cameron's recent discoveries in the Tanganyika region. The writer justly rates Lieut. Cameron's work as of the highest importance, and we earnestly hope that the appeal of the Royal Geographical Society for subscriptions to enable Cameron to complete his work will be liberally responded to. Already 1,494*l.* have been subscribed, including 500*l.* from the Geographical Society; but of this, 544*l.* will be swallowed up by expenses already incurred, so that there is really only 950*l.* available. This, "it is confidently hoped, will be largely increased as soon as the people of England are fully aware of the necessities of their young countryman in the heart of Africa, and of the glorious work that he is bravely attempting to do, alone and single-handed."

DR. ALLCHIN will give the course of lectures on Comparative Anatomy and Zoology this session at University College, London, pending the appointment of a successor to the late Prof. Grant. The introductory lecture will be delivered to-day, at 4 P.M.

MR. BOWDLER SHARP, of the British Museum, delivered a lecture on "The Birds of our Globe," on Tuesday, January 5, in the private music-room at Mr. N. Holmes's residence, Primrose Hill. The lecturer, commencing with the "Accipitres," or birds of prey, gave a concise description of the various families and genera of birds, terminating, according to modern classification, with the "Struthiones," illustrating at the same time the different groups by an elaborate series of paintings specially prepared for the occasion by Herr Keulemans, the well-known ornithological artist.

WE have received a foretaste of the forthcoming new edition of the "Encyclopædia Britannica," in the shape of a separate reprint of Mr. A. R. Wallace's carefully written article on "Acclimatisation." After an examination of a considerable number of instances, Mr. Wallace concludes: "On the whole, we seem justified in concluding that, under favourable conditions, and with a proper adaptation of means to the end in view, men may become acclimatised with at least as much certainty and

rapidity (counting by generations rather than by years) as any of the lower animals."

THE great hurricane which swept over Hong Kong on the 22nd and 23rd of September last, and to which we referred at length last week, appears, from official reports, to have caused considerable damage in the Government Gardens. Mr. Ford, the superintendent, reports that the largest trees suffered the most severely, several of the oldest and largest being entirely destroyed. Many other trees, although not destroyed, were severely damaged, having nearly the whole of their branches broken off, while many which were thus damaged, but which had not their roots broken or strained, will, in course of time, produce fresh branches and foliage. A considerable number of smaller trees and shrubs were entirely destroyed, having been broken off close to the ground, while others were blown over and a great portion of their roots so much exposed to air and light as to threaten their ultimate destruction. Operations were at once commenced for the preservation of as many of the trees and shrubs as there was any prospect of saving, and the greater part of them were replanted and protected by supports. The flower-pots containing plants in various parts of the gardens were broken in great numbers, and the plants for the most part much disfigured. In the nurseries, likewise, the plants in pots were thrown out, but no serious damage was effected. With regard to trees in different parts of the town, which come under the Forest Department of Hong Kong, Mr. Ford says: "I have observed that in nearly all cases where trees were blown down in the typhoon of September 1871, and those trees were again set upright and have continued to grow up to the late typhoon, they have again fallen, and in several cases are this time entirely destroyed; thus proving, as a general rule, that when once a tree suffers so severely as to cause its prostration, little reliance can be placed on that tree ever afterwards continuing or becoming a sound and healthy one." In the Surveyor-General's Report to the Colonial Secretary of Hong Kong, on the damage caused by this hurricane, it is regretted that no record remains of the pressure of the wind, owing to the meteorological station connected with the Government Hospital being swept away by its force. It is further said, however: "That the island was not many miles distant from the focus of the cyclone is proved not only by the intensity of the wind, but by a feature known to exist only within such a focus, namely, the abrupt intervals of calm during the height of the gale. These lulls were instantaneous, often lasting as long as four or five minutes; and, alternating with the most violent gusts, equally sudden, the conjoint action of the two became, as it were, that of a battering ram."

MANY experiments have been tried in France to test the effects of cold on railway axles. Many engineers suppose that accidents to wheels do not result from any diminution of tenacity of the metal, but merely from its losing all its elasticity owing to the frost hardening the surface of the earth. A fact which can be adduced as a strong argument in favour of that theory was observed by the inhabitants of Montmartre during the last period of frost. The passing of the trains which run so frequently through the Batignolles tunnel at a distance of half a mile was heard by them day and night, which is never the case in ordinary circumstances. As soon as the thaw set in the trains ceased to be heard; the earth having resumed its former elasticity, the sounds were dissipated as before. It has been observed by French railway engineers that thaws are apt to lead to the breaking of axles and chains. The elasticity being only partially recovered, many shocks affect the trains when running at a fast rate, and are apt to lead to catastrophes.

MR. W. PHILLIPS, of Shrewsbury, proposes to publish, under the title of "Elvellacci Britannici," dried specimens of the larger

ascomycetous fungi. To persons forming collections of our indigenous fungi, Mr. Phillips's fasciculi will be useful, since similar collections have hitherto principally comprised only the *Hymenomyces*. Mr. Phillips will be assisted by various well-known mycologists, and he proposes to issue a very limited number of copies at twelve shillings each fasciculus of fifty species.

M. Amédée Guillemin has published through Hachette a very interesting work on Comets, profusely illustrated. All the modern theories are discussed, from Descartes to Schiaparelli, a number of traditions and stories connected with comets being also introduced.

WE omitted to mention in last week's notice of the anniversary meeting of the French Academy the speech delivered by M. Dumas on De la Rive. It is a part of the duty of the perpetual secretaries to deliver such *loges* at each anniversary meeting. That duty has been performed by each perpetual secretary from Fontenelle to our days, and the collection of these *loges* is an important part of the *Académie* publications. M. Bertrand is at present engaged in preparing the *loge* of M. Elie de Beaumont, which will be delivered in 1876.

A COMMISSION, nominated by the Geographical Society of Paris, and composed of Admiral Fluriot de Langle, MM. Delesse, Charles Grad, H. Farry, and Jules Girard, has just published some instructions to navigators to aid in their study of the physical geography of the sea. These instructions, which the Society sends gratuitously to everyone who is willing to turn to account, in the interest of science, his stay on board ship, point out, in a style sufficiently precise and elementary to come within the comprehension of all, the principal points on which observations should be made, and the best methods to be adopted for collecting useful particulars.

At St. Peter's College, Cambridge, on April 6, there will be an examination for a Natural Science Scholarship. The subjects of examination will be botany, chemistry and chemical physics, geology, and comparative anatomy and physiology. No candidate will be examined in more than two of the above-mentioned subjects. Applications to become candidates must be made on or before March 29 to the Rev. J. Porter, tutor of the College, who will give all necessary information.

By the death of Prof. William Macdonald, of St. Andrew's University, the chair known as that of "Civil and Natural History" becomes vacant. Dr. Macdonald held it for twenty-four years. The post has from the first been practically a sinecure, and almost seems to have been instituted for the sake of the professor. We wonder if the Senate of St. Andrew's will allow their University to be befooled by the appointment of a successor to Dr. Macdonald in this unique chair of "Civil and Natural History."

WE are glad to see that it is intended to form a society at Watford, having for its object the investigation of the meteorology, geology, botany, and zoology (including entomology, ornithology, &c.) of the neighbourhood, and the dissemination amongst its members of information on natural history and microscopical science. The evening meetings of the society will be held (by permission) in the rooms of the Watford Public Library, and during the summer months field meetings will also be held. It is proposed that the annual subscription be ten shillings, without entrance fee. The names of ladies and gentlemen willing to join the society will be received by Dr. Brett, Watford House, by Mr. Arthur Cottam, St. John's Road, Watford, and by Mr. John Hopkinson, jun., Holly Bank, Watford. It is hoped that a sufficient number of names will be received within the next few days to warrant a meeting being called to found the society in the course of the present month.

THE Institution of Civil Engineers seems to be one of the most prosperous of our scientific societies. On its books on Nov. 30, 1874, were 2,130 members; its income for the past year was upwards of 10,000*l.*, and its investments amount to nearly 33,000*l.*

A RARE phenomenon, says the *Malta Times*, occurred in the forenoon of Monday, the 21st ult. During a strong wind from the south-west, which had prevailed for two days previously, the sea suddenly rose several feet and flooded the moles and roads surrounding the harbours, causing four or five steamers, moored between the Custom House and Calcare Rise, to snap their stern hawsers like packthreads, and carrying away boats that were hauled ashore in the French and other creeks. The sea then receded as suddenly as it rose, leaving portions of the bottom of the harbour exposed, upon which men and boys might be seen collecting fish and other marine animals that had been left aground by the retiring water. Shortly afterwards the sea resumed its ordinary level. Similar phenomena have been noticed occasionally during the course of many years.

M. W. DE FONVILLE has published a small volume, "Le Mètre International définitif," giving an account of the determination of the metre and the negotiations relating to it from 1789 to 1874.

THE *Daily News* of Monday has a letter from its correspondent on board the *Challenger*, giving a few details in addition to those contained in the recent *Times*' letter. From Hong Kong the ship was to return to Manila and other places, as far as New Guinea, then make for Yokohama, Japan.

THERE was a slight shock of earthquake at Malta on Friday last, at 1 P.M.

THE additions to the Zoological Society's Gardens during the past week include two Razor-billed Curassows (*Mitua tuberosa*) and a Yarell's Curassow (*Crax carunculata*) from South America, presented by Mrs. A. E. Nash; seven Golden Agoutis (*Dasyprocta aguti*), from Guiana; five Guira Cuckoos (*Guira piririgua*) from Pará; an Ani (*Crotophaga ani*), two Orinoco Geese (*Chenalopex jubata*), two Red-tailed Guans (*Ortalida ruficauda*), a Spotted Cavy (*Cavayensis papa*), and a Collared Pecary (*Docotyles tajacu*), all from South America, purchased.

## THE PRESENT CONDITION OF THE ROYAL SOCIETY\*

(Extracted from the President's Address at the Anniversary Meeting.)

*Committee of Papers.*—The strength of the Society being represented by its publications, the Committee of Papers is the one whose functions are unquestionably the highest and most onerous, as they are the most closely scrutinised by the Fellows and the public.

Every member of the Council is included in this committee, which meets after almost every Council meeting, and no part of its duties is at present performed by a sub-committee. It appears to me to be very doubtful whether this arrangement, even if the best, can last, owing to the greatly increased number of papers now communicated and their augmenting bulk, and to the value of their contents being less easily estimated as the subjects of scientific research become more specialised. As it is, in the majority of cases but few of the members present can judge of the merits of many of the papers; and it is not easy after a protracted Council meeting, and one occupied with promiscuous business, to fix the attention of a large committee upon subjects with which but few members present may be familiar. It is true that the committee is aided in all cases by the written opinions of careful and impartial referees, and by the special attainments of our secretaries, and that it is most desirable that the sometimes divergent opinions of these should be weighed by

\* Continued from p. 178.



others as well as by experts in the subjects of the papers. But for all this a committee of the whole Council is not necessary; and though I should not be disposed to advocate a return to a system once pursued of resolving the committee into sub-committees charged with special subjects, I think it possible that some other plan may meet the difficulties of the case and relieve our overburdened Council of much labour. A possible plan for relieving both the Council and the committee, while securing as careful a scrutiny of the papers as we now have, would be a division of the labours of the committee, and an addition of extra members to its number, chosen from among the Fellows, who should continue in office throughout the session. This, or some plan of the kind, would have the advantage of engaging more of the Fellows than at present in the affairs of the Society; and I feel sure that so responsible a position as that of Extra member of the Committee of Papers would be accepted with pride by those Fellows who are most competent to discharge the duties.

It seems convenient to refer here to suggestions that have been made to me as to the expediency of breaking up our transactions or proceedings, or both, into sections devoted to physics and biology respectively, or even subdividing them still more. This separation has been advocated on the ground that science has become so specialised that no scientific man can grasp all its subdivisions, that the mixed publications are cumbersome and difficult to consult, and that private libraries are now overburdened with the publications of Societies, of each of which a small part would suffice for all their possessors' wants. There is no question that this, if now an evil, will soon become intolerable, for our publications increase rapidly in number of contributions and in their bulk. There are, however, so many considerations to be discussed before any system of relief can be adopted, that I confine myself to stating the subject as it has been urged upon me.

The Society's library now comprehends 36,270 volumes and 10,000 tracts, the most considerable collection of scientific works in the possession of any private body; and in respect of Transactions and Proceedings of scientific academies, societies, and institutions, I believe it is unrivalled among public bodies.

A complete Catalogue of the Scientific Books, MSS., and Letters, which I regret to say is unaccompanied by any historical or other information regarding the library, was printed in 1839. Another catalogue of the miscellaneous literature and letters was printed in 1841; and there is also a MSS. catalogue of maps, charts, engravings, and drawings, which number upwards of 5,000.

For some years past the Library Committee, indefatigable in steady endeavour, have greatly increased the value and efficiency of our library; and in 1873, previous to leaving old Burlington House for our present apartments, it ordered a rearrangement of the whole, and the preparation of a new catalogue, which is being proceeded with as fast as the current duties of the officers will permit.

In the mean time the Catalogue of Transactions and Journals is printed for working purposes, and will be added to until such time as the general catalogue is ready for press.

The collection of Oriental MSS. presented by Sir William Jones in 1792, and added to by his widow in 1797, was largely consulted by several of the distinguished foreigners who assembled at the Oriental Congress in London last September. From conversation with some of these gentlemen, I learnt that the collection contains many documents of the greatest value and rarity, together with some that are unique; and it may be worth the consideration of the Council, whether they would not be more useful if transferred to, or deposited in, the India Office or some other Oriental library, where they would be consulted to greater advantage than here. At present they occupy part of the room devoted to our archives.

The two most noteworthy additions to the library during the past year have been the MSS. on logic and mathematics of our late fellow Prof. Boole, presented by his widow; and Dr. Fayer's collection of forty-seven original drawings of the poisonous snakes of India, which are of interest in connection with his and Dr. Brunton's experiments on snake-poisons, printed in our "Proceedings."

The apartments devoted to the library afford space for twenty years' addition at the present rate of increase; they are remarkably commodious; and those who assembled at our Soiree last spring and saw them for the first time lighted up and decorated will consider with me that they are not only a noble suite of

apartments, but that they are in keeping with the purposes and the high position of the Society.

You are aware that the Council resolved that the Catalogue of Scientific Papers should be continued through the decade 1864-1873. This work is now progressing under direction of the Library Committee, who have had charge of the undertaking from the commencement. The necessary funds are granted by a vote of the Council, and we may hope, in the course of the coming year, that the seventh volume of this important work will be ready for publication; and we confidently trust that the Government will extend its liberality by printing this as it did the former volumes of the series. The total outlay upon the six volumes already published (which comprise papers published between 1800 and 1863) has been 8,936*l.* 12*s.*, of which 3,720*l.* 15*s.* 6*d.* (the cost of preparation) was defrayed by the Society, and the rest (the cost of printing, paper, and binding) by the Treasury; against which must be set the proceeds of sale, repaid to the Treasury in occasional amounts, the last within the present year, making a total amount of 1,000*l.*

The number of copies of the Society's Transactions distributed gratuitously to institutions and individuals not Fellows of the Society is now 209, and of the Proceedings 325.

*House Committee.*—The great labours of this committee in connection with the removal into the apartments we now occupy had not terminated at the beginning of the past session; and various matters have still to be attended to. That the arrangements the committee has made have given satisfaction to the Fellows at large has been amply acknowledged. We are, indeed, greatly indebted to them for the knowledge, experience, and time, all so freely given in our service, as also to the knowledge of our requirements and the practical views of our Assistant Secretary, upon whom fell the duty of suggesting the best disposition of the apartments throughout this large and commodious building. Lastly, I would beg your permission to record the services of the eminent architect, Mr. Barry, who has throughout shown the greatest regard to our position and requirements, and but for whose professional ability enlisted in our service we might have found ourselves as ill as we are now well accommodated.

*Funds and Bequests.*—*The Donation Fund.*—In 1828 our former President, Dr. Wollaston, invested 2,000*l.* in the Three per Cents for the creation of a fund, the dividends from which were to be expended liberally "from time to time in promoting experimental researches, or in rewarding those by whom such researches have been made, or in such other manner as shall appear to the President and Council for the time being most conducive to the interests of the Society in particular, or of science in general." There is no restriction as regards nationality: but members of Council are excluded from participation during their term of office.

To this fund many liberal additions were made. Mr. Davies Gilbert gave 1,000*l.*; Warburton, Hatchett, Guillemand, and Chantrey each contributed 100 guineas. From these gifts, and by accumulations, the fund in 1849 had increased to 5,293*l.* With subsequent contributions, and a bequest of 500*l.* by our eminent Fellow the late Sir Francis Ronalds, the total, as shown by the balance-sheet now in your hands, amounts to 5,816*l.* 1*s.* 1*d.* In addition to the balance-sheet already referred to, a detailed statement of grants from the Donation Fund is, in accordance with a resolution of Council, published with the Report of the Anniversary Meeting.

Sir Francis Ronalds died in 1873; his bequest (reduced by payment of legacy duty to 450*l.*) was made, as declared in his will, in recognition of the advantages he had derived when Honorary Director of the Observatory at Kew, from the sums granted to him out of the fund to aid him in the construction of his photographic apparatus for the registration of terrestrial magnetism, atmospheric electricity, and other meteorological phenomena.

Of the grants made during the past session, I would especially mention 100*l.* to Dr. Dohrn in support of the Stazione Zoologica at Naples, in which two British naturalists, Mr. Lankester and Mr. Balfour, have recently made a valuable series of observations on marine animals.

Among the others were a grant of 25*l.* to Dr. Carpenter for the purpose of constructing an apparatus to illustrate the theory of oceanic circulation in relation to temperature, and 50*l.* in aid of the Sub-Wealden Exploration. In reference to this last, I should remark that, in recognition of the important scientific results which have been obtained from the Sub-Wealden

boring (which is now carried to a depth of 1,000 feet), and in view of obtaining further assistance from her Majesty's Government towards the work, the Council authorised me to lay before the Chancellor of the Exchequer such a statement as I should judge appropriate, with the object of obtaining a grant from the public purse in aid of the boring.

In pursuance of this resolution, I joined the Presidents of the Geological Society and of the Institution of Civil Engineers in presenting a memorial, which was most favourably received, and was answered by a promise on the part of the Treasury of 100*l.* for every 100 feet of boring that should be accomplished, down to a depth of 2,000 feet.

The Government Grant (of 1,000*l.* per annum) continues to be expended with satisfactory results. I must refer you to the report which will be published in our Proceedings for the statement of the grants, making, however, special allusion to Dr. Klein's work on the Anatomy of the Lymphatic System, towards which 100*l.* from this fund was granted, and by means of which copies have been distributed to the best advantage in this country and abroad.

The Scientific-Relief Fund slowly augments, and has been of the greatest service. It is almost unique among charities in costing nothing in the working, and in being inaccessible to direct or indirect canvassing. The amount hitherto expended in relief since its establishment has been 2,240*l.*, extended to fifty-two individuals or families.

The Gilchrist Trust.—One of the most munificent bequests ever made in the interest of science is that of the late Dr. Borthwick Gilchrist, a retired Indian medical officer, well known as the author of the "Grammar of Hindostani."

Dr. Gilchrist was an intimate friend of Dr. Birkbeck, Joseph Hume, Sir John Bowring, and others of the advanced Liberals of fifty years ago, and took part in the establishment of the "London University," now University College. He died in 1841, leaving his large fortune to be devoted, after his wife's death, to "the benefit, advancement, and propagation of education and learning in every part of the world, as circumstances permit," the trustees having an "absolute and uncontrolled discretion" as to the mode of applying it. The income of the Trust, which is being gradually augmented by the sale of building-lots at Sydney, where Dr. Gilchrist had invested a considerable sum in the purchase of an estate with a view to its ultimate rather than its immediate productiveness, now amounts to about 4,000*l.* per annum. The trustees have created various scholarships for bringing young men of ability from India and the colonies to carry on their education in this country; and they have also given assistance to various educational institutions which they considered to have a claim for occasional help from the fund, such as the Working Men's College in London and the Edinburgh School of Arts; and they have instituted short courses of scientific lectures to working men in London, Manchester, Leeds, and Liverpool.

The trustees now desire to do something effectual for the advancement of learning; and a scheme—subsequently submitted to the Council of the Royal Society—was suggested by Dr. Carpenter, the secretary of the Trust, as one which seemed to him to be the most effectual for carrying out this object; and it was adopted by the trustees on his recommendation.

In a letter addressed to myself in June last, Dr. Carpenter informed your Council that the trustees of the fund had resolved to employ a portion of it in the promotion of scientific research, and empowered him to submit the following liberal proposal to the consideration of your Council: namely, the trustees propose annually to entertain the question of placing 1,000*l.* at the disposal of the Council of the Royal Society to be expended in grants to men of proved ability in scientific research, but who, from their limited pecuniary means, are precluded from prosecuting inquiries of great interest by the necessity of devoting to remunerative work the time they would wish to devote to such inquiries; the Council of the Society to undertake on their part to recommend to the trustees suitable subjects of inquiry, competent men circumstanced as indicated, and the sum to be assigned in each case. The trustees desire, further, that the grants should not be regarded as eleemosynary, but rather as studentships carrying with them scientific distinction, and not as rewards for past work, but as means for work to be done.

Upon this communication (in which you cannot fail to perceive not only an enlightened regard for the interests of science on the part of the trustees, but, on the part of their secretary, an accurate perception of the best means of supplying one of

the greatest scientific needs), your Council appointed a committee to report on the proposal. Their labours are already concluded; the proposition has been accepted, but under stipulation for fulfilment of the following conditions by applicants for the grants:—

That the grants should be made for one year only in each case, though subject to renewal.

That the recipients be designated *Gilchrist Students* for the year in which the grants are made.

That no application for grants be received except it has been approved by the President and Council of any one of the six Societies—namely, the Royal, Astronomical, Chemical, Linnean, Geological, and Zoological; and that all applications be submitted to a committee, consisting of the Presidents of the six Societies together with the officers of the Royal Society, which committee shall recommend the applicants to the Gilchrist Trustees.

That a form of application be prepared setting forth the general objects of the Gilchrist Studentships, and the conditions upon which they are conferred.

That each student furnish, at the end of the year for which the grant is made, a report of his progress and results, signed by himself and countersigned by the President of the Society through which the application was transmitted.

Simple and acceptable as such a scheme appears, it may prove by no means always smooth in the working. It will be easy to find subjects, and candidates too; but the trustees must not expect in every case a full annual harvest for what they annually sow, or that some of the seed will not be productive of a crop of good intentions rather than good fruits. Putting aside all the temptations to procrastination that pre-payment fosters, there is the fact that every subject of scientific research presents a labyrinth in which the investigator may wander further and further from the main gallery, always following some tempting lateral track leading to discovery, but never either reaching the end of it, or getting back to that which he set out to follow.

We must, however, hope for the best results from so munificent an endowment of scientific research, and watch with the deepest interest the progress of an experiment, the means for instituting which, after being urgently called for from the Government and our Universities, are now forthcoming from private resources.

The *Wintringham Bequest*.—Hitherto this curious bequest has, so far as the Society is concerned, proved alike profitless and troublesome, as will appear from a few particulars of its history.

Sir Clifton Wintringham, Bart., a Fellow and son of a Fellow of this Society, died at Hammersmith, January 10th, 1794, and bequeathed 1,200*l.* Three per Cent. Consols (payable twelve months after the decease of his wife) to the Royal Society, subject to the condition that within one month of the payment of the annual dividends in each year the President should fix on the subjects for three essays in Natural Philosophy or Chemistry, and submit them to the Society to be adopted by secret ballot. The subjects were then to be advertised in the papers of London, Paris, and the Hague: the essays were to be sent to the Royal Society within ten months of date of advertisement, each author to deliver ten copies; and the President and nine members of Council were to choose the best, and then to have made a silver cup of 30*l.* value, to be presented to the successful essayist on the last Thursday in December. In case of failure the dividends were to be paid to the treasurer of the Foundling Hospital.

Lady Wintringham died in 1805; but the Royal Society heard nothing of the bequest until 1839, when steps were taken to obtain possession of the fund. The Foundling Hospital put forward their claim; legal proceedings were taken, costs being paid out of accumulated dividends; and in 1842 the Royal Society were put in possession of the 1,200*l.* stock. Owing to the essential difficulties of carrying out the conditions of the testator's will, the dividends have ever since been paid to the Foundling Hospital.

The Council, desirous that those difficulties should be overcome, have at different times appointed a committee to examine the question and suggest, if possible, a solution; but no satisfactory conclusion has yet been arrived at.

The *Handley Bequest*.—Mr. Edwin Handley, of Old Bracknell, Berks, was a country gentleman, and the possessor of a considerable landed and personal estate in Berkshire and Middlesex. He died in 1843, having bequeathed the bulk of his

property, after the decease of his two sisters, to the Royal Society.

The last of these ladies died in 1872, since when certain legal formalities have been complied with, and the claims of the Royal Society to the landed estates under the Mortmain Act have been brought before the Court. In February last the Master of the Rolls decided that "the gifts to the Royal Society, so far as they relate to pure personality, are good charitable gifts, but otherwise void." The personality as set forth in the "Bill of Complaint," comprises 6,033*l.* 7*s.* 5*d.* Three per Cent. Consols, 1,904*s.* 17*s.* 2*d.* Reduced, and 41*l.* 18*s.* 5*d.* Bank of England Stock.

By the terms of the will, the Society is to preserve the property intact in value, as a Fund Principal, the income of which is to be applied to the rewarding inventions in art, discoveries in science, physical or metaphysical ("which last and highest branch of science," to quote the testator's words, "has been of late most injuriously neglected in this country"), or for the assistance of fit persons in the prosecution of inventions and discoveries. The rewards or assistance are to be granted annually, or after longer periods, to British subjects or foreigners, according to the impartial decision of the President and Council.

A delay in distributing the bequest has arisen from the absence of a party on whom it was essential to serve a decree; this has, however, been now served, and there is every reason to believe that the suit will go forward; in which case we may hope to receive the proceeds early next year.

*The Dircks Bequest.*—Mr. Henry Dircks, of Liverpool, and latterly of London, who died in 1872, has bequeathed the residue of his property (about 4,000*l.*) after payment of debts and charges, to the Royal Society, Royal Society of Literature, Chemical Society, and Royal Society of Edinburgh, in equal shares and proportions, in furtherance of their several objects. As, however, it is possible that certain claims to the residue under the Bankruptcy Act, dating from 1847, may be set up, we are advised that the estate cannot be administered without the aid of the Court of Chancery, which has been appealed to accordingly.

*The Ponti Will.*—Lastly, it is my duty under this head to inform you that our secretary has received a communication from the Secretary of State for Foreign Affairs, to the effect that the late M. Girolamo Ponti, of Milan, has bequeathed a portion of his immense property to the "Academy of Science of London." As, however, it does not appear what Society is indicated under this title, and as the relatives of the testator intend to dispute the will, the Council, as at present advised, will take no steps in the matter. I have further to observe that under the terms of the will, the Academy of Science will, if it accepts the trust, be burdened with annual duties and responsibilities respecting the distribution of the proceeds which would be altogether inconsistent with the position and purposes of the Royal Society.

*The Fairchild Lecture.*—This lecture no longer appears in the annual financial statement of your treasurer. Though an obvious anachronism and regarded almost from the first with little sympathy either within or without our walls, it should not pass away without a notice from the Chair. In February 1728 Thomas Fairchild, of Hoxton, gardener, bequeathed 25*l.* to be placed at interest for the payment of 20*s.* annually for ever for preaching a sermon in the parish church of St. Leonard's on Tuesday in Whitsun week on "the wonderful works of God in the creation, or on the certainty of the resurrection of the dead proved by certain changes of the animal and vegetable parts of the creation." From 1733 to 1758 most of the lectures were read by Archdeacon Denne, one of the original trustees, who in 1746 contributed all his lecture-fees to the fund, which, with a subscription raised by the trustees, enabled them in 1746 to purchase 100*l.* South Sea Stock. Subsequently this stock was offered to and accepted by the Society: the transfer was made in 1757; and from that date the lecturers were appointed by the President and Council. The lectures have been regularly delivered, but of late years to empty pews, under which circumstances the Council, after full deliberation, unanimously resolved that it was desirable to relieve the Society from the Fairchild Trust, and that to this end application should be made to the Charitable Commissioners. The regular forms having been gone through, the Trust was transferred to the Commissioners in November last, and thus disappears from our balance-sheet.

The Croonian and Bakerian lectures are given annually as

usual; and those of this year appear in our Proceedings. These do not diminish in interest and importance.

*The Davy Medal.*—The Council has accepted the duty of annually awarding a medal, to be called the Davy Medal, for the most important discovery in chemistry made in Europe or Anglo-America. The history of this medal is as follows:—

Our former illustrious president, Sir Humphry Davy, was presented by the coalowners of this country with a service of plate, for which they subscribed 2,500*l.*, in recognition of his merits as inventor of the Safety Lamp. In a codicil to his will Sir Humphry left this service of plate to Lady Davy for her use during her life, with instructions that after her death it should pass to other members of the family, with the proviso that, should they not be in a situation to use or enjoy it, it should be melted and given to the Royal Society, to found a medal to be awarded annually for the most important discovery in chemistry, anywhere made in Europe or Anglo-America.

On Sir Humphry's death the service of plate became the property of his brother, Dr. John Davy, F.R.S., who, in fulfilment of Sir Humphry's intentions, bequeathed it after the death of his widow, or before if she thought proper, to the Royal Society, to be applied as aforesaid. On the death of Mrs. Davy the plate was transferred to the custody of your treasurer, and, having been melted and sold, realised 736*l.* 8*s.* 5*d.*, which is invested in Madras guaranteed railway stock, as set forth in the treasurer's balance-sheet. The legacy duty was repaid to the Society by the liberality of the Rev. A. Davy and Mrs. Rolleston.

The style and value of the medal, and the steps to be taken in reference to its future award, are now under the consideration of the Council, and will, I hope, be laid before you on the next anniversary. The acceptance of the trust has not been decided upon without long and careful deliberation, nor without raising the question of the expediency of recognising scientific services and discoveries by such trivial awards as medals, and of the extent to which the awards entrusted to our Society are depreciated by their multiplication. My own opinion has long been that some more satisfactory way of recognising distinguished merit than by the presentation of a medal might be devised, and that the award might take a form which would convey to the public a more prominent and a more permanent record of the services of the recipients, such as a bust or a portrait to be hung on our walls, or a profile or a record of the discovery to be engraved on the medal, which might be multiplied for distribution or sale to Fellows and to foreign Academies. In short, I consider awards of medals without distinctive features to be anachronisms; it is their purpose, not their value, which should be well marked; and the question is, whether that purpose is well answered by their being continued under the present form.

*Instruments.*—The small but remarkable, and, indeed, classical collection of instruments and apparatus belonging to the Society, and for which there was no accommodation in old Burlington House, was, on our migration from Somerset House in 1857, by order of the Council, deposited in the Observatory in the Kew Deer-Park, near Richmond, then under the control of the British Association.

The instruments have been now for the most part brought back and placed in our instrument-room, and will, I hope, at no distant period be accessible to the Fellows.

## SCIENTIFIC SERIALS

*Cosmos*, Guido Cora's Italian Geographical Journal, Nos. 4 and 5 (in one), contains a long and carefully compiled article on Italian travellers in Egypt from 1300 to 1840; Payer and Weyprecht's official account of the Austro-Hungarian Arctic Expedition; and the continuation of F. M. Prsevalski's exploration of Eastern Mongolia and Thibet. There are, besides, Notes on Gordon's Nile Expedition,—an Austrian naturalist, Ernst Marmo, has been appointed to accompany Col. Gordon; there is a short account of the travels of a Persian youth, Abdul Kerim, in Tunisia. The part contains an excellent map of the border region between Persia and Beluchistan, compiled from the maps of Major St. John and the English Admiralty.

## SOCIETIES AND ACADEMIES

LONDON

Anthropological Institute, Dec. 22.—Prof. Busk, F.R.S., president, in the chair.—Mr. J. Park Harrison exhibited tracings of late Phœnician characters from the south-west of

Sunatra. They are said to be still in use, and differ entirely from early letters in other parts of the island. The natives have a tradition that some descendants of Alexander settled there; and if Nearchus' second expedition, the account of which is lost, reached the Bay of Bengal, the date, Mr. Harrison considered, would agree sufficiently well with the letters. His sailors were principally Tyrians.—Col. Lane Fox read a paper on early modes of navigation, in which he described the various contrivances employed by savage races for transit on the water. Commencing with the simple trunk canoe, the author traced the development of the art of boat and ship-building through the stages of stitched plank canoes, bark canoes, rafts, outrigger canoes, single and double, the double canoe, the variation of hull, the weather platform, the rudder, and the rude sail, and gave the distribution of their many forms and modifications. It was argued that the rude bark float of the Australian, the Tasmanian, and the Ethiopian, the catamaran of the Papuan, the dug-out canoe of the New Zealander, and the built-up canoe of the Samoan, were survivals representing successive stages in the development of the art of shipbuilding, not lapses to ruder methods of construction as the result of degradation; that each stage supplies us with examples of what at one time was the perfection of the art countless ages ago. Some of the more primitive kinds spread over nearly the whole world, whilst others had a more limited area of distribution. Taken together, they enabled us to trace back the history of shipbuilding from the time of the earliest sculptures to the commencement of the art.

Victoria (Philosophical) Institute, Jan. 4.—A paper by Mr. J. E. Howard, F.R.S., entitled "Early Dawn of Civilisation considered in the Light of Scripture," was read by the author.

## BERLIN

German Chemical Society, Dec. 14.—A. W. Hofmann, vice-president, in the chair.—Two physiological researches of interest were communicated by Prof. Jaffé, of Königsberg. Nitrobenzol being poisonous, it appeared reasonable to expect, what experiments fully bore out, that ortho-nitrotolual, which resists oxidation most completely, should be more poisonous than the two isomeric bodies. *Para-nitrotolual* is almost without effect upon the health of dogs. Five grains daily were given for several weeks without producing more than a slight inflammation of the mucous membrane of the stomach, and at last jaundice. The urine contained *nitrobenzoic acid (para)*, but a comparatively small quantity of it only. The rest of the substance had become transformed into *nitrohippuric acid*. This acid was found combined with urea, and therefore insoluble in ether. As in similar experiments, when substituted toluals or benzoic acids had been given to animals, substituted hippuric acids had not been found in the ethereal solution, it is not improbable that such acids, though not found, were yet present in the shape of urea compounds. *Para-nitrohippuric acid* constitutes orange prisms, fusing at 129°, and forming well-defined salts with Larium and with silver, different from a nitrohippuric acid formerly described by Bertagnini. In the urine of one individual dog a new substance has been discovered by the same *savant* in the following manner:—The alcoholic extract precipitated with  $H_2SO_4$  yielded sulphate of urea, soluble in water, and the sulphate of a *new base*,  $C_8H_8N_2O_3$ , which combines with one molecule of HCl, but has a sour reaction, and dissolves baryta. It forms prisms, melting and decomposing at 213°. The dog has unfortunately been lost.—Messrs. Forst and Zincke, in re-preparing a product formerly prepared from silver by Limpricht and Schwanert, and described as two substances isomeric with hydrobenzoin and isohydrobenzoin,  $C_{14}H_{12}(OH)_2$ , have found this opinion to be erroneous; their experiments yielding but a mixture of the two latter bodies. There are, therefore, only two, and not four hydrobenzoinis in existence.—M. Wroblewsky described meta-acetylitolual, prepared from meta-bromotolual, a liquid boiling at 158°, and yielding isophthalic acid and two isomeric sulpho-acids.—A. Ladenburg has undertaken the useful task of submitting to rigid experiments the opinion generally adopted, that the position of *one* lateral chain in benzol is indifferent with regard to the substance thus constituted; in other words, that no isomeric aromatic bodies can exist with only one lateral chain. He showed this time the identity of ordinary benzoic acid with benzoic acid prepared from phenol, and the complete identity of the three phenols prepared from the three different oxybenzoic acids. The proof will have to be completed by further researches, in which Mr. Ladenburg is still engaged.—Messrs. Michaelis and Ananoff have undertaken

researches respecting the constitution of phosphorous acid, for which they have established the formula  $HP = O(OH)_2$ . Without entering into details, we can only say that the method consisted in the action of  $C_6H_5PCl_4$  on phosphorous acid, when no phosphorous chloride,  $PCl_3$ , but only oxychloride,  $PCl_2O$ , was formed. They have also prepared a monobasic phenylphosphorous acid,  $C_6H_5P = O(OH)H$ .—Prof. Nilson, from Upsala, described as the best method for extracting *selenium* the treatment of the flue-dust with cyanide of potassium.—T. Piccard has found in the sperma of the salmon, besides a new base, *protannin*, lately described by Mieschke, also *sarkin* and *guanin*.—C. Schibler described a volumetric method for determining  $CO_2$  in carbonates without introducing temperature and barometric pressure into the calculus. The method consists in making a "normal" analysis with a pure carbonate and comparing the volume of  $CO_2$  obtained with that of the unknown quantity of  $CO_2$  yielded by the substance analysed the same day.—H. Uppenkamp described hexylic sulphocyanide and isosulphocyanide.—C. Biedermann and L. Ledoux reported on the formation and properties of mesitylic phenol,  $C_8H_{12}O$ .—A. W. Hofmann communicated his researches on fractions of beech-tar distilling above 260°. By oxidation they yield a phenolic substance,  $C_8H_{10}O_3$ , in which  $H_2$  may be replaced by  $Br_2$ , and a quinone,  $C_8H_6O_3$ , which takes up  $H_2$  when treated with reducing agents. Prof. Hofmann further reported on the following experiments of Mr. McCreath:—The action of water on guanidine,  $CH_5N_3$ , consisting in the loss of ammonia and the formation of urea; the action of anhydrides has been studied, when it was found that benzoic anhydride acts on guanidine in a similar way, producing ammonia and dibenzoyl-urea.—A. Oppenheim has submitted crystallised pure glycerine to distillation. The boiling point corrected proved to be very constant at 290°. Nearly every manual and dictionary of chemistry contains erroneous data in this respect, although the same number has already been published in 1860 by Mendeleeff.

## PARIS

Academy of Sciences, Dec. 28, 1874.—This was the anniversary meeting of the Academy, an account of which appeared in last week's NATURE, p. 178.

## BOOKS AND PAMPHLETS RECEIVED

COLONIAL.—On the General Theory of Duplex Telegraphy: Louis Schwendler (Asiatic Society of Bengal).—On Earth Currents: Louis Schwendler (Asiatic Society of Bengal).—Second Annual Report of the Secretary of Agriculture of Victoria (Melbourne, Australia).

FORBIGN.—Anthropologische Beiträge: Georg Gerland (Max Niemeyer, Halle).—Classification de 160 Huiles et Graisses Vegetales, 2nd Edition: M. Bernardin (Annot-Brackmann, Gand).—A. Dobsinai Jegbarlang: Dr. Krenner Josef Sancier, Die Esholue von Dobtschan, Dr. Jos. Alex. Krenner (K. Ungar, Budapest).—Jahrbuch der Kaiserlich-Königlichen Geologischen Reichsanstalt, Band xxiv. (Wien).—Az Aradály Funel Obblöben: E. Stahlberger (K. Ungar, Budapest).—Essai sur la Vie et les Ouvrages de L. A. J. Oulelet (F. Havez, Brussels).—Verhandlung des Naturhistorischen Vereins der Preussischen Rheinlande und Westfalens: Dr. C. J. Andrä (Max Cohen and Sohn, Bonn).—Sitzungsberichte der niederösterreichischen Gesellschaft für Natur- und Heilkunde zu Bonn (Max Cohen and Sohn, Bonn).—Mémoires de la Société de Physique et d'Histoire Naturelle de Genève, vol. xxii. Part II. (Rambot & Schuchardt, Genève).

## CONTENTS

PAGE

THE GEOLOGICAL SURVEY OF VICTORIA . . . . .	181
LIVINGSTONE'S "LAST JOURNALS," II. . . . .	182
BUCHANAN ON THE CIRCULATION OF THE BLOOD . . . . .	184
OUR BOOK SHELF:—	
Angel's "Animal Physiology" . . . . .	185
"the Gardener's Year Book" . . . . .	186
LETTERS TO THE EDITOR:—	
Absence of Microscopic Calcareous Organic Remains in Marine Strata charged with Siliceous Ones.—HENRY J. CARTER . . . . .	186
The Constant Currents in the Air and the Sea.—Wm. FERREL . . . . .	186
Mud Banks on Malabar Coast.—HENRY F. BLANFORD . . . . .	187
Ring Blackbird.—C. M. INGLEY . . . . .	187
ON THE MORPHOLOGY OF CRYSTALS. By Prof. N. S. MASKELYNE, F.R.S. . . . .	187
TWO REMARKABLE STONE IMPLEMENTS FROM THE UNITED STATES. By CHAS. C. ABBOTT (With Illustrations) . . . . .	190
PROTECTION FOR INVENTIONS. . . . .	191
FRANCIS KIERNAN, F.R.S. . . . .	193
THE CONSTANT THAW. By W. DE FOVILLE . . . . .	196
EARTHQUAKES IN THE PHILIPPINE ISLANDS. By Dr. A. B. MEYER . . . . .	193
THE TRANSIT OF VENUS . . . . .	194
NOTES . . . . .	195
THE PRESENT CONDITION OF THE ROYAL SOCIETY, II. . . . .	196
SCIENTIFIC SERIALS . . . . .	199
SOCIETIES AND ACADEMIES . . . . .	199
BOOKS AND PAMPHLETS RECEIVED . . . . .	200

THURSDAY, JANUARY 14, 1875

## THE APPROACHING ECLIPSE OF THE SUN

THE energetic action of the Council of the Royal Society, and the wise liberality of the present Government in matters connected with scientific investigation, have saved us from what would have been little short of a national disgrace.

If all goes well, the approaching eclipse of the Sun—during which, as stated by Mr. Hind, better opportunities for the observation of totality will be afforded than are likely to be again offered before the close of the present century—will be observed by English parties in Siam, and either in Burmah or in some island in the Bay of Bengal.

The work to be done, as determined by the Council of the Royal Society, and the investigations which have led up to it and render it of so great an importance, have been stated in Monday's *Times* in an article which enters so fully into the problem, that we take the following extracts from it:—

“In 1860, Mr. De la Rue, a member of the Astronomer Royal's Expedition, and Father Secchi, a delegate of the Italian Government, were enabled, by the photographs of the eclipsed Sun, which were then taken for the first time, to place beyond all doubt that the strange red prominences seen round the dark body of the Moon at the moment of total eclipse really belonged to the Sun's atmosphere. This was a fine achievement, for it settled a point which had been in debate for a century and a half. Important though it was, however, it was fairly dwarfed by the results of the expeditions sent by the Indian, French, German, and Austrian Governments to observe the eclipse of 1868 in India—dwarfed because in the meantime an instrument had been placed in the hands of the astronomer of a perfectly new kind of power. It was no longer a question of place and shape, but of material. Janssen, Tennant, Pogson, Weiss, and many others observed the eclipse with the spectroscope, and its story was that the prominences which in 1860 had been proved to belong to the Sun really consisted of a glowing gas, or a mixture of such gases. But the spectroscope was not of use only during eclipses. Before 1868 Kirchhoff by its means had stated the approximate composition of the Sun's atmosphere, taken as a whole; and immediately after the eclipse of that year it was found that by its aid the brightest part of the Sun's atmosphere, to which alone up to this time attention had been directed, could be seen without an eclipse at all. Indeed, we were soon told that outside the bright round disc that we see there was an envelope of glowing hydrogen gas, to which envelope the name of chromosphere was given, and into which are frequently injected from below magnesium and sodium, and, more rarely, iron and the other heavy metals. Here, then, we were enabled roughly to sort out into strata the various substances already detected by Kirchhoff; that is, it was established that the gases and vapours were not all mixed up together, but that the lightest, such as hydrogen, magnesium, and sodium, were generally at top, and that, as the others were shot up from time to time, and some of them more frequently than others, some of them were, as a rule, located lower down in the solar atmosphere than the others.

“The eclipse of 1869 the Americans had all to themselves, and splendid use they made of it. It has been well said that the line of totality which swept across the

United States was one continuous observatory. In this eclipse the halo of light outside the prominence-envelope was the subject of special inquiry, and now this was photographed, as the prominences themselves had been in 1860. At the same time that this was done it was established that there was some other substance lying even outside the hydrogen.

“The eclipse of the next year, 1870, was best seen in different parts of the Mediterranean. The English Government, applied to by the Royal and Astronomical Societies, at once supplied the requisite funds and ships, and sent three parties; the United States Government sent an equal number; and the French one party, the Spanish and Italian astronomers observing locally. Further facts were obtained of great value; but the weather was not good, and the true nature of the corona was not considered to be finally established. Another appeal was therefore made to the Government in 1871 by the Presidents of the British Association, the Royal Society, and the Astronomical Society combined, to observe the eclipse of that year in India. The Government responded with a remarkable promptitude, granting everything that was required. The Indian Government not only had strong parties of their own, but largely aided the observers sent out from England; and the French Government were again represented by the illustrious Janssen, who had made his exit from beleaguered Paris in a balloon to observe the phenomenon. The Dutch Government had an expedition in Java. The combination of the results of the parties, most of whom had splendid weather, led to the following most important conclusions:—

“First, the corona was now at last photographed, under nearly the same instrumental conditions, from three different places, and the exact similarity of the pictures proved beyond all doubt that part of the corona was a solar appendage. The size of the Sun was enormously increased by this result. Secondly, evidence was obtained rendering it extremely probable that the light of the outer parts of the true solar corona, or *coronal atmosphere*, as Janssen proposed to call it, was stronger in the violet and ultra-violet parts of the spectrum than elsewhere. Thirdly, it was proved that for some distance above the hydrogen envelope, as seen without an eclipse, less bright hydrogen existed. The so-called chromosphere, therefore, was a layer of brighter hydrogen and other vapours. Other results were obtained, but the above are those on which we wish to lay the greatest stress, for reasons we now proceed to state.

“Since the eclipse of 1871 the every-day observations of the Sun and of his lower atmosphere (the chromosphere), which can be rendered visible by the spectroscope, have gone on with great vigour, especially in Italy. A special study of the chromosphere has been made at the expense of the United States Government, at an elevation of some 9,000 feet, on the Rocky Mountains; and extensive laboratory researches have been undertaken with the view of enabling us to understand better the various phenomena observed. We shall now only refer to the two latter branches of the work. Prof. Young, on the Rocky Mountains, in the clear air at so great a height, saw that the chromosphere was much more complicated than it appears to those who observe in the plains. Among other things, he found that the vapour of the metal calcium, the principal characteristic lines of which require perfect atmospheric conditions to enable us to see them, was very often present along with magnesium, but his observation left it doubtful which vapour extended highest generally. The laboratory experiments proved that, in the case of any one metal present in the Sun, the metal behaves exactly the same in the Sun's atmosphere as it does when driven into vapour by the passage of the electric current between the carbon poles of an electric lamp. At the greatest distance from the poles the spec-

trum of the vapour is the simplest (single-lined), in the core of the arc it is complex (many-lined). Now, in the case of some of the elements present in the Sun, we have a spectrum as complete as that we get in the core of the arc, in others only a line or two, so far as we know at present. In fact, we have hydrogen and the metals of the alkalis and alkaline earths and the metals of the iron class with almost complete spectra on the one hand, and on the other only a few lines indicating the presence of such metals as zinc and lead.

"Nor is this all. A most diligent search has been made for metals of the tungsten, antimony, silver, and gold classes among the metals, and entirely without success. Dealing, however, with the metals the record of which is most obvious in the solar spectrum, hydrogen, magnesium, calcium, sodium, and the metals of the iron group, the order we have given is not only the order in which they would be met by a body entering into the solar atmosphere, but it is the order of the old atomic weights. Further, although it is true that at present we do not know much about the spectra of the stars, we do know that the stars with the simplest spectra are stars which only give clear indications of hydrogen, or hydrogen and magnesium, or hydrogen, magnesium, sodium, and so on. A star as it gets gradually older may apparently give us a spectrum belonging to a gradually increasing depth of the solar atmosphere as it exists at this moment.

"So far we have said nothing about metalloids; that is, those elementary bodies, such as oxygen, carbon, nitrogen, sulphur, and the like, which make up more than half of the parts of our planet most easily got at. Of metalloids in the chromosphere none have been detected, but a year ago a paper was presented to the Royal Society pointing out that their record would appear not to be entirely absent from the solar spectrum; in fact, that we have exactly such a record as we should expect if this large class of bodies existed in a comparatively cool part of the atmosphere at some height above the hotter lower strata. It was also shown that, granting this, we could explain the various classes of stars in the heavens by supposing that as a star got older and colder the metalloids were enabled to exist lower down in the atmosphere, and thus to change the character of the spectra of stars bright and hot into that associated with those which are dim and possibly colder, until at last the metalloidal rain, so to speak, falling on the metals below, gives the material of a future crust. It will be seen, then, that the work since 1871 has been assuming more and more a chemical character, and associated with this are physical questions of the greatest interest, not only bearing on the kinetic theory of gases, but which may eventually help us to follow more intelligently than we can now the matter of a nebula till it forms part of the cooled crust of a planet.

"The present line of inquiry, then, is to determine the chemical nature of a section of the Sun's atmosphere reaching from the photosphere to the extreme limit of the corona, some hundreds of thousands of miles away. This with the old conditions of observation, would have been a hopeless task to accomplish. But, side by side with the results to which we have drawn attention, new methods of investigation have been introduced, and among these the development of spectrum photography deserves first mention. The spectrum of the corona can now be photographed with the same ease as the prominences were photographed in 1860, and if such photographs can be obtained, it is certain that the work of four minutes will in all probability be more valuable than laboratory work extending over as many years. But even spectrum photography would not have been applicable under the best conditions unless side by side with it an instrument had been introduced which is destined to effect a great revolution in astronomical observation. In the Siderostat we have an instrument, suggested by

Hooke and perfected by Foucault, which enables us to do away with telescope stands and their equatorial mountings altogether. This is effected by moving a large, perfectly plain mirror in front of the object glass of a telescope, the telescope itself being horizontal and at rest. This arrangement permits of spectroscopes and photographic apparatus being attached to the eye-piece end of the telescope of even greater dimensions than the telescope itself. The special and novel method of attack to which Mr. De la Rue referred as having been suggested to the Council of the Royal Society can now be guessed by our readers; and unless we have missed the mark altogether, it should now be seen that the work of the proposed expedition of this year is the fruit and crown of the work begun in 1860 and carried on by the English and other civilised Governments since that time. . . ."

We have little to add to the foregoing, except that it appears to us a sad thing, and little to the credit of the leaders of astronomy in England, that such strong arguments should have to be put forward at all in favour of eclipse observations. *Every total eclipse of the Sun ought to be observed as a piece of the national business with as great a regularity as the transit of the Moon over the meridian of Greenwich.* Nay, we may go further, and say with *greater* regularity; for we know something about the motion of the Moon, and we can predict her place with some accuracy, but he would be a bold man who would predict the shape and condition of the Sun's surroundings in the forthcoming eclipse. Practical men might possibly urge the greater utility of one kind of observation, but a man of science who does this is to our mind not a true man of science at all.

Mr. Hind has sent us the following most valuable information regarding the actual conditions of observation, referring at somewhat greater length to Siam, whither English astronomers are invited by the King of Siam.

"Although the course of the central line in this eclipse is mainly a sea-track, yet in its passage from the Nicobar Islands, in the Bay of Bengal, to Siam, better opportunities for the observation of totality will be afforded than are likely to be again offered before the close of the present century.

"Adopting the elements of the *Nautical Almanac*, in which the place and hourly motions of the moon are derived from Hansen's Tables, I find the following points upon the central line:—

Greenwich Mean Time.	Longitude East.	Latitude North.	Sun's Altitude.
H. M. S.			
19 8 0	92 36.9	7 34.2	71 8
19 14 0	94 20.2	9 1.6	67 51
19 23 0	97 9.5	11 10.4	62 38
19 26 0	98 9.9	11 52.7	60 51
19 28 30	99 2.5	12 27.3	59 18
19 32 0	100 19.7	13 15.9	57 6

"If we lay down these points on the Admiralty Charts of the Bay of Bengal and Province of Tenasserim (British Burmah), we find the central line passing a little north of Kalkul, in the Island of Camorta, Nicobars, and on making a direct calculation for Kalkul, totality is found to commence at 1h. 21m. 38s. local mean time, and to continue 4m. 27s., the sun being at an altitude of about 70°. I take the position of Kalkul, 6h. 13m. 31s. E. and 8° 11' 8" N. The central eclipse, passing from the Nicobars, traverses Bentinck Island, where the maximum duration of totality is 4m. 17s., and runs between Mergui and Tenasserim, rather nearer to the former place than to the latter. By direct calculations I find—

Totality begins at Mergui at . . . 2h. 0m. 6s. local time.

Duration	...	...	4m. 6s.
Sun's altitude	...	...	61°

Totality begins at Tenasserim at 2h. 2m. 7s. local time.

Duration	...	...	3m. 57s.
Sun's altitude	...	...	60°

Nearly midway between the above places, or where a "Conical Peak" is marked on the Admiralty Chart, the total eclipse continues 4m. 14s.

"Bangkok (Siam)" will be found to lie rather north of the central line. The circumstances of the eclipse at this point are as follows (long. 6h. 42m. 6s. E.; lat. 13° 42' 5" N.)

"The partial eclipse begins at oh. 51m. 6s. mean time at Bangkok, 134° from the north point towards the west, and 168° from the vertex eastward, for direct image; the sun at an altitude of 76°. The total eclipse begins at 2h. 13m. 7s. and continues 3m. 54s., the sun about 57° high, and the partial phase ends at 3h. 33m.

"The invitation extended to British and other astronomers by the King of Siam, to observe this interesting and important phenomenon within his dominions, may be expected to bring together a number of competent observers in the vicinity of Bangkok; and in selecting localities for astronomical stations, it must be very desirable to be enabled to form some idea of the extent of error to which the predicted track of the central line may be subject. On this account I have made a further direct calculation for the Siamese capital, taking the moon's position from the American Ephemeris, in which the Tables of Prof. Peirce are employed. With elements thus modified, the partial phase is found to commence at oh. 50m. 42s., or 24 seconds only earlier than by Hansen's Tables; totality begins at 2h. 13m. 32s., and continues 3m. 59s. Generally I may remark that between the longitudes of the Nicobars and Siam, the track of central line by the American Tables has about five minutes greater latitude than that given by Hansen's Tables.

"(For any point in Siam in the neighbourhood of Bangkok, the Greenwich time of commencement of the partial eclipse may be given closely by the following formula:—

$$\cos. w = -0.03471 - [0.12053] \sin. l + [0.12430] \cos. l, \cos. (L - 172^\circ 10') \\ t = 18h. 55m. 58s. - [3.71146] \sin. w + [3.83098] \sin. l \\ - [3.83692] \cos. l, \cos. (L - 4^\circ 14')$$

The Greenwich mean time of beginning and ending of totality may be found from

$$\cos. w = -17.5228 - [1.74615] \sin. l + [1.68419] \cos. l, \cos. (L - 150^\circ 25') \\ t = 18h. 17m. 58s. \mp [1.09177] \sin. w + [3.77248] \sin. l \\ - [3.84594] \cos. l, \cos. (L + 16^\circ 32' 8')$$

"In the above formula  $L$  expresses the east longitude of the point from Greenwich, taken positive;  $l$  is its geocentric latitude, and the quantities within the square brackets are logarithms. Upper sign for beginning of totality, lower sign for ending.

"It has been stated above that the eclipse of next April may probably be the most favourable for observation that can take place during the present century. In the eclipse of 1878, July 29, the duration of totality is shorter, and the same is the case in the eclipses of 1882, 1887, 1900, &c. In the eclipse of 1886, August 29, the only easily accessible and favourable station appears to be the Island of Grenada, in the West Indies, where the duration of total eclipse is 3m. 15s., commencing at 7h. 10m. A.M. local time, with the sun at an altitude of 20°; thence the course of the central line is over the North and South Atlantic Oceans, to a point on the African coast north of St. Philip de Benguela. In the eclipse of 1892, April 26, the central line appears to have a sea-track through nearly its whole extent, if indeed it touches land at any point, which requires a more precise computation than I have yet made to determine. The eclipse of 1893, April 16, is the only one that can compare favourably, as regards length

of totality and track, with that of the present year: at a point in the vicinity of Ceara, in the Brazils, the duration of total eclipse is 4m. 44s. with the sun at an altitude of 76°."

We may conclude our article by stating that the observations for which the Council of the Royal Society have obtained a promise of a grant in aid amounting to 1,000*l.* will be limited to photographing the spectra of the chromosphere and coronal atmosphere.

For this purpose a siderostat has been placed at the disposal of the Royal Society, and another will be ready in time. These instruments have been made by Messrs. Cooke and Sons, of York, who have in some respects, with their usual skill, improved upon Foucault's model. As an instance of international courtesy which must not be unrecorded, we may state that M. Leverrier would have placed the original instrument devised by Foucault himself, and now at the Paris Observatory, at the disposal of the Royal Society, had it not been constructed solely for the latitude of Paris.

Besides siderostats, it is proposed that equatorials shall be sent out also, provided with apparatus for spectrum photography, quartz prisms and lenses being generally employed.

The Secretary of State for India (Lord Salisbury), the Viceroy of India, and the Admiralty officials are all hearty in their co-operation. It is hoped that Col. Tennant and a strong staff of assistants will also be on the scene of action.

Although the time is short, then, we may fairly hope that good work will be done. Of this we may be assured, that whether the observers be many or few, whether the weather be good or bad—and General Strachey considers the chances all that can be wished for—the action of the Royal Society and of the Government will redound to the credit of English science, and a bright page may be added to the scientific annals of our time.

EDITOR

#### COUNT RUMFORD'S COMPLETE WORKS

The Complete Works of Count Rumford. (Published by the American Academy of Arts and Sciences.)

THE American Academy of Arts and Sciences is doing good service and teaching the Old World a sound practical lesson by undertaking the publication of such a work as this. The question of what form should be given to the monument of a great man is often discussed, and fairly admits of much debating; but when the benefactor of humanity whose memory is to be preserved is one who has done the high service of extending the boundaries of science, we may safely venture to affirm that whatever other monuments may be erected, the first should be a complete and carefully compiled record of all his researches. The demand for this arises from the manner in which the results of original scientific work are usually communicated to the world, *i.e.* in the form of papers read before learned societies or contributed to magazines, or published as pamphlets, and thus scattered far and wide and liable to be forgotten or even altogether lost. Such a publication should precede all other forms



of memorial on the simple principle that strict justice should precede generosity. The object being to perpetuate and honour the memory of such a man, the first step should be to do *justice* to his memory, and this cannot be done unless his works are collected in an available and presentable form. The most perfect of monumental epitaphs is Sir Christopher Wren's in St. Paul's Cathedral—

"Lector, si monumentum requiris, circumspice."

A handsomely printed record of the life-work of any original investigator might bear a similar inscription. The justice of such an epitaph would be absolutely complete.

That Count Rumford himself took this view of the matter is evident from the fact that on recovering from the illness which in 1793-94 nearly finished his career, he left Bavaria and came to London in September 1795 for the purpose of publishing a collection of these same essays which the American Academy have now reprinted, and that he left London in 1802 when their publication was completed. His narrow escape from death had evidently suggested the necessity of losing no more time in thus doing justice to his own memory.

But it is not every scientific investigator who finds an appreciative monarch, like the Elector of Bavaria, willing to reward so munificently the services of intellect; there are but few who can afford to indulge in the expensive luxury of printing books which the uneducated millions and the ill-educated thousands are equally incapable of appreciating. The professional publisher is prohibited from undertaking such work, from the simple fact that much activity in that direction would land him in the Bankruptcy Court. Here, then, is a clear demand for uncommercial effort, if the memory of great men is to be preserved and the full advantages of their labour are to be reaped by their fellow-creatures.

We should do well here in England by at once commencing a great national effort in this direction. Local patriotism would be appropriately directed by starting the subscription for a republication fund in every town or village which has the honour of having given birth to a worthy worker in science; and our learned societies might carry out the work as the American Academy has done in this case. Birmingham has done well in erecting the noble statue of Priestley that fitly decorates the approach to the Birmingham and Midland Institute; but the student who admires the sculptured presentation of the great philosopher performing his great experiment has considerable difficulty in finding the full original record of this scientific exploit. How very interesting to the general student, either of science or of human nature, would be a complete collection of all the far-scattered and diverse works of Priestley's powerful and wide-grasping intellect! At present they are practically buried. The same may be said of the majority of the inductive philosophers, from Horrocks, Gilbert, and Galileo, down to the name on the latest scientific obituary. Such collections of the works of our great philosophers would be a worthy complement to the Royal Society's invaluable index of scientific papers.

The following list of the subjects treated in the three volumes already published sufficiently indicates the variety of Rumford's work:—

A Method of determining the Velocity of Projectiles; Experiments to determine the Force of fired Gunpowder; Experiments with Cannon, and Improvements in Field Artillery; The Production of Air from Water; The Quantities of Moisture absorbed from the Air by various substances; The Propagation of Heat in Fluids; The Final Cause of the Saltness of the Sea; Chemical Affinity and Solution, and the Mechanical Principle of Animal Life; The Propagation of Heat in various substances; The Source of the Heat which is excited by Friction; An Inquiry into the Weight ascribed to Heat; The Nature of Heat, and the Mode of its Communication; Experimental Investigations concerning Heat; Reflections on Heat; Historical Review of the various Experiments of the Author on the subject of Heat; Experiments and Observations on the Cooling of Liquids in Vessels of Porcelain, gilded and not gilded; Account of a curious Phenomenon observed on the Glaciers of Chamouni; New Experiments on the Temperature of Water at its Maximum Density; The Propagation of Heat in Liquids; Adhesion of the Particles of Water to each other; The slow Progress of the Spontaneous Mixture of Liquids; The Use of Steam as a vehicle for transporting Heat; The Means of increasing the Quantities of Heat obtained in the Combustion of Fuel; Description of a New Boiler; The Use of the Heat of Steam in the making of Soap; Experiments on Wood and Charcoal; Heat developed in the Combustion and in the Condensation of Vapours; The Capacity for Heat of various Liquids; The Structure of Wood, &c.; Chimney Fireplaces; the Management of Fire, and the Economy of Fuel; The Construction of Kitchen Fireplaces and Kitchen Utensils; The various Processes of Cookery, and Proposals for improving that most useful art; The Management of Fires in closed Fireplaces.

One remarkable feature of Count Rumford's papers is their simplicity and clearness. They are all readable, to the least initiated in scientific technicalities. There is no pedantry, no vain display of unnecessary formulæ; but, on the contrary, every page displays the clear and purely scientific intellect of the writer. It matters not whether he is discussing the proper shape of a saucepan lid, the flavouring properties of a red herring, or the deepest mysteries of molecular force; whether he describes his method of eating a plate of hot pudding, or of reorganising and commanding the Bavarian army—the same thoroughness and simplicity of pure inductive and deductive reasoning prevails. He seems to have been incapable of thinking of any subject other than systematically and scientifically; and to this fixed habit of mind his marvellous success in the solution of the most difficult social and military problems is clearly traceable. His last effort, the essay on "The Nature and Effects of Order," upon which he laboured so long during the last years of his fading life, and which the feebleness of his over-tired intellect prevented him from finishing, was apparently intended as a vindication of his peculiarly strict and systematic method of doing everything, which was so miserably misunderstood by his eulogist Cuvier, his intensely French wife, and the Frenchmen by whom he was surrounded and ridiculed during his latter days. To do such work as Rumford achieved, and do it all so coolly without any sentimental flourishes, without drums, or flags,

or processions, or trumpets, or inaugurations, was to them quite incomprehensible, and hence their misrepresentation of his work and character, when they tell us that he looked upon mankind merely as objects of experiment, and not with any philanthropic feeling, and that "il ne s'agissait que de nourrir les ouvriers assez bien pour entretenir cher eux la force musculaire des membres." Those portions of his essays in which he describes the work done at the "House of Industry" in Munich utterly refute these mistaken views of Rumford's character.

I have read nothing more humiliating in reference to the still remaining magnitude of popular ignorance of the merest rudiments of physical science than some of these essays. Take as an example this passage on page 177 of vol. ii. "The waste of fuel in culinary processes, which arises from making fluids boil *unnecessarily*, or when nothing more would be necessary than to keep them *boiling hot*, is enormous. I have no doubt but that much more than half the fuel used in all our kitchens, public and private, in the whole world, is wasted precisely in this manner." Again, he tells all the world that "nothing is so ill-judged as most of those attempts that are so frequently made by ignorant projectors *to force the same fire to perform different services at the same time*. The heat generated in the combustion of fuel is a *given quantity*, and the more *directly* it is applied to the object on which it is employed so much the better, for less of it will escape or be lost on the way; and what is taken away on one side for a particular purpose can produce no effect whatever on the other side where it is not."

These, and quite a multitude of similarly simple and obvious applications of the elementary laws of heat, were not only expounded but practically applied by Rumford eighty or ninety years ago, and we are still blundering on and blindly violating them. Every laundry is still filled with the steam of wastefully boiling coppers, and almost every saucepan in the United Kingdom and elsewhere is wastefully used for the unnecessary distillation of water, not one cook in 500 knowing that water is no hotter when it boils violently than when it "simmers" gently. Nine-tenths of the ranges exhibited at the last Exhibition of South Kensington were constructed in direct violation of the simple and obvious principles above stated, and our ironmongers still persist in making "kitcheners," "ranges," &c., with the fire in the middle, the oven on one side, and a boiler on the other, or even with ovens on both sides; instead of placing the fire on one side, the oven next, and boiler beyond, to utilise residual heat. In most of our best English houses a range capable of cooking for a dinner party of thirty or forty people is kept going to supply water for a tumbler of toddy, although Rumford demonstrated again and again the vast economy and convenience of having several fires in every establishment where the demands for cooking are variable, and his essays give descriptions and drawings of how these fires should be arranged.

It must be remembered that Rumford was no mere theoretical writer or lecturer, but he practically carried out on large and small scale every principle he expounds. He cooked for thousands and tens of thousands in his military kitchens, his House of Industry, in private houses, at the Foundling Hospital in London, at public institutions in Dublin, Edinburgh, &c.; and in these practical

demonstrations weighed his fuel, registered its consumption, and published the results.

Thus, at the Foundling Hospital he roasted 112 lbs. of beef with 22 lbs. of coal, the residual heat from the roaster going on to the boiler. In the public kitchen at Munich, where his arrangements were fully carried out, he frequently—as certified by the Colonel and Councillor of War—prepared the ordinary hot dinner for one thousand persons, and "the expense for fuel has not amounted to quite twelve kreutzers" (less than  $4\frac{1}{2}d.$ , or one-fiftieth of a farthing for each person). It must be remembered, in reference to this, that Rumford's soup requires five hours' boiling, or rather heating at the boiling-point.

I have little doubt that the merited failure of all the recent competitors for the Society of Arts' prize was due to the absence of scientific knowledge, and of that systematic inductive method of proceeding by the aid of which Rumford wedded theory to practice, and brought forth such important results. His researches on the "Propagation of Heat in Fluids," upon which our present knowledge of the phenomena of the convection of heat is mainly founded, were suggested by burning his mouth with a spoonful of thick rice soup, and were further elaborated in order to determine the best material for soldiers' clothing. His celebrated demonstration of the immateriality of heat was in like manner a result of cannon-boring. Every essay in these three volumes supply similar illustrations of the action and reaction of theory and practice upon each other, and their mutual development thereby.

One of the most curious and least-known of his speculative efforts is that upon "the mechanical principle of animal life." They bear upon many of the molecular speculations now occupying so much attention, and are sufficiently interesting to demand full quotation of the following essential paragraphs:—

"Suppose an open vessel—as a common glass tumbler, for instance—containing a piece of money, a small pebble, or any other small solid opaque body, to be filled with water and exposed in a window, or elsewhere, to the action of the sun's rays. As a ray of light cannot fail to generate heat when and where it is stopped or absorbed, the rays, which, entering the water and passing through it, impinge against the small solid opaque body at the bottom of the vessel, and are *there absorbed*, must necessarily generate a certain quantity of heat, a part of which will penetrate into the interior parts of the solid, and a part of it will be communicated to those colder particles of the water which repose on its surface.

"Let us suppose the quantity of heat so communicated to one of the integrant particles of the water to be so small that its effect in diminishing the specific gravity of the particle is but just sufficient to cause it to move upwards in the mass of the liquid with the very smallest degree of velocity that would be perceptible to our organs of sight were the particle in motion large enough to be visible. This would be at the rate of about *one hundredth part of an inch* in a second.

"This velocity, though it appears to be slow in the extreme when we compare it with those motions that we perceive among various bodies by which we are surrounded, yet we shall be surprised when we find what a rapid succession of events it is capable of producing.

"If we suppose the diameter of the integrant particles or molecules of water to be *one-millionth part of an inch* (and it is highly probable that they are even less), in that case it is most certain that an individual particle, moving

in a quiescent part of that fluid with the velocity in question, would run through a space equal to *ten thousand times the length of its diameter in one second*, and consequently would come into contact with at least *six hundred thousand* different particles of water in that time.

"Hence it appears how inconceivably short the time must be that an individual particle, in motion, of any fluid can remain in contact with any other individual particle, not in motion, against which it strikes in its progress, however slow that progress may appear to us to be through the quiescent mass of the fluid!

"Supposing the contact to last as long as the moving particle employs in passing through a space equal to the length of its diameter—which is evidently all that is possible, and more than is probable—then, in the case just stated, the contact could not last longer than  $\frac{1}{10000}$  part of a second! This is the time which the cannon bullet, flying with its greatest velocity (that of 1,600 ft. per second), would employ in advancing two inches.

"If the cannon bullet be a *nine-pounder*, its diameter will be four inches, and if it move with a velocity of 1,600 feet in a second, it will pass through a space just equal to 4,800 times the length of its diameter in one second. But we have seen that a particle of water moving 100th of an inch in a second actually passes through a space equal to 10,000 times the length of its diameter in that time. Hence it appears that *the velocity with which the moving body quits the space it occupies* is more than twice as great in the particle of water as in the cannon bullet!"

I am sorry that space does not permit further quotation of this essay, in which the author goes on to show that inequality of fluid temperature is one of the leading phenomena of animal life; that respiration raises the heat in one part, while insensible perspiration cools another; that stimulation of all kinds is accompanied with disturbance of temperature and the consequent motion of particles, which he regards as the life of fluids.

Of course it is not supposed that Rumford, by these ingenious speculations, supplies any mechanical solution of the mystery of *conscious* vitality, but his suggestions have the merit of showing that a vast amount of molecular activity is a demonstrable result of simple well-known facts. He obtains this activity without invoking the aid of those profound assumptions in which the brilliant imaginations of modern mathematicians so luxuriously revel when they reason upon the vibrations, gyrations, &c., of the component particles of interatomic atmospheres.

In spite of all the progress we have made in physical science, these essays, written for the most part during the last century, contain a great deal that is still suggestive and worthy of thoughtful reading both by popular students and experts in physical and social science. This is especially the case in the essay on "The Propagation of Heat in Fluids," reprinted in vol. i. of this work. Many of the conclusions and speculations are now demonstrably erroneous, but some of the suggestions—more particularly those in chap. iii. on the Chemical Action of Light—are worthy of far more attention and investigation than they have yet received. They are avowedly very bold, but the author tells us frankly that their temerity "has not been entirely without design;" that "philosophers may be *entirely* and they may be *provoked* to action," and that he has "endeavoured to use both these methods," even with conscious imprudence, for the purpose of ex-

citing them to further investigation of the subjects for which he has such "passionate fondness."

It will be well if the republication of these essays contribute to the fulfilment of Rumford's enthusiastic wishes.

W. MATTIEU WILLIAMS

### THE SILKWORM COCOON

*Le Cocon de Soie. Histoire de ses transformations, description des races civilisées et rustiques, production et distribution géographiques, maladies des vers a soie, physiologie du cocon et du fil du soie. Deuxième Edition. (Paris: J. Rothschild, 1875.)*

WE have received an advance copy of M. E. Duseigneur-Kléber's monograph, "Le Cocon de Soie," dated for 1875, the get-up of which is calculated at once to arrest attention and excite interest. The 248 quarto pages of clearly printed letterpress containing his information, admirably arranged in methodic form, are accompanied by thirty-seven plates executed in photo-topography, and a map of the world indicating the localities where silkworms are cultivated. Twenty-eight of the plates are devoted to the illustration of the different types of cocoons from different countries, of which as many as 195 are figured from photographs.

Such a work was, he says, quite impossible twenty years ago, and it is only in consequence of diseases that it is possible now. Each district prided itself on the silk it produced, and did not trouble to know what other countries were doing, until the enfeeblement of some and the destruction of other types by disease compelled growers to seek fresh types from a distance, and thus accumulated the information which M. Duseigneur-Kléber has compiled and presented in this attractive form. Many of the types he thinks will probably not be again met with in cultivation, and it is only through noticing and recording facts as they came under his notice during a series of years that his information has been obtained. Looking to the past, he finds that from 1700 the years of disease were 1702, 1720, 1750, 1787, but the chroniclers give no intimation of the character of the disease. In 1810 the "plague" was described by M. Paretto. The affected worm exhibited small spots all over its body, which were gangrenous, and appeared to be caused by the same disease now known as "Muscardino."

Among the practical points noticed in the first section of the work are the following: That the red or black mulberry produces more vigorous worms than the white; that the old notion of selecting bright-coloured cocoons for breeding has given place to the belief that dull yellow are the best; that the practice of limiting the time of copulation of moths is injurious; that while the worms are making their cocoons, the ventilation of the buildings, too often neglected, is even more important than warmth. The symptoms of the disease known as Pebrine are detailed, but its cause seems to be not known. That its recurrence coincides with unusually wet and cold seasons is established, but whether it results from a parasitic vegetation whose germs are carried in the air is still a subject for experiment. When the external indications are well marked, the silk reservoir is found much diminished in volume. The spots which appear on the skin continue

through successive moultings; the feet become atrophied; if the worm dies, the body dries up without putrefaction; if it lives on to metamorphosis the moth shows all the characters of hydropsy.

M. Duseigneur-Kléber has paid much attention to the method of work performed by the worms in the construction of their cocoons. A healthy worm (in disease they act irregularly) selects a suitable spot for its operations, where there is space for its whole body to move about, supporting itself generally by its two last feet only. Having carefully arranged from twig to twig the outline of its work, its movements quicken, and at the end of three hours the first outer layers of its nest are complete, and the sphere of operations is then limited. At the end of five or six hours the exact form of the cocoon is indicated, still remaining diaphanous and rarely coloured yellow. So far it is easy to watch the worm at work, and it is seen that it holds itself in a semicircle or curved like an S. After a little more work the cocoon loses its transparency, and begins to be coloured. The author, however, by methodically cutting into cocoons continued his observations, and found that the worms never stopped to repair the damages thus caused, but going on uninterruptedly, the layers formed within the cut layer rapidly covered the aperture. Remaining attached by its hind legs, a worm forms its layers in the shape of an 8, changing its position from time to time, generally moving but a short distance, though sometimes turning completely round and continuing on the opposite side of the cocoon. He calculates that, varying according to race, there are from thirty to forty different layers in a cocoon, and the time occupied in its construction is from three-and-a-half to four days. Whatever may be the condition of the outer layers, the innermost coat formed is of the finest thread, and the end towards which the head is turned is the tenderest, thus providing a soft and elastic cradle for its metamorphosis.

The book is especially intended for practical purposes, and contains information as to the outward appearance that may guide a dealer in purchasing cocoons, a special chapter being given to each kind of defect. Not only double cocoons, but cocoons in which three or even four worms have worked together, are mentioned.

In the enumeration of silk-rearing districts, besides the well-known localities of France, Italy, the Austrian Empire, China, and Japan, the following less known are among those mentioned:—California, Mexico, Guatemala, Peru, Brazil, Chili, the Argentine Republic, Algeria, and Armenia. In South America especially increased attention is being paid to silk-production, and it gives promise of becoming a very important industry.

#### OUR BOOK SHELF

*The Straits of Malacca, Indo-China, and China; or, Ten Years' Travels, Adventures, and Residence Abroad.* By J. Thomson, F.R.G.S. Illustrated. (London: Sampson Low and Co., 1875.)

MR. THOMSON'S sojourn in the countries with which his book is concerned seems to have extended from 1862 onward, during which time he evidently had plenty of leisure to visit various places on the south-east and east of Asia, extending from Penang to Peking. We can heartily recommend his modest work to anyone

wishing to obtain a fair idea of the social life, scenery, and productions of the districts which he visited, and in which he usually sojourned for some time, including the Malay Peninsula, Siam, Cambodia, Hong Kong, Amoy, Peking, and other coast-towns of China. He also sailed a considerable distance into the interior of China, up the Yang-tse-Kiang, and made a short walking tour into the interior of Formosa. Mr. Thomson put his eyes, his ears, and his camera (for he is an accomplished photographer) to excellent use, so that we do not know any work of the size that conveys a juster and fuller idea of the manners and customs of the various peoples whom he visited. Mr. Thomson makes no pretension to have travelled in the interests of science, but only to be a photographer and an observer of the ways of men. Nevertheless, throughout the work occasional jottings are introduced that may be of interest to the botanist and geologist. Among the very first pages he hazards some conjectures as to the cause of the love of brilliant colours among tropical men, birds, and flowers, which are evidence of some observation and thought. "Perhaps," he says, "our men of science might be able to tell us whether the heat of the oriental sun develops in flowering plants a craving for the absorption of certain colours of the solar spectrum, and for the reflection of others; whether, indeed, the electric affinities of plants in this way are affected by temperature. Can we, in the same way, account for the brilliant plumage of tropical birds, in which homogeneous red, yellow, and blue are very conspicuous, and also for the liking which uncultured Eastern races show for the reds, blues, and yellows."

Mr. Thomson gives some very interesting information about the Chinese, whom he found wherever he went, mingling as managers or factors in the life of every place, always bent on making money, and generally succeeding. He seems to have studied their ways intimately, and gives some very curious facts with regard to the powerful associations, or guilds, into which they band themselves everywhere. His visit to Siam, and the account of his intercourse with the King and other dignitaries, will be found entertaining as well as informing.

One of the most valuable chapters in the book, certainly the most interesting to archaeologists and ethnologists, is Mr. Thomson's account of his visit, in 1866, to the magnificent ruins in Cambodia, probably the grandest, if not the most interesting ruins in the world. The illustrations to this part of the work will give the reader a fair idea of the nature of these ruins, their colossal and beautiful architecture, and their wonderful sculpture, giving evidence of a vigorous and high civilisation, the lapse or obliteration of which is one of the strangest events in the history of the world. We have much to learn yet about the history of these ruins and of the people of which they are almost the only remains. "A richer field for research," Mr. Thomson rightly says, "has never been laid open to those who take an interest in the great building races of the East, than that revealed by the discovery of the magnificent remains which the ancient Cambodians have left behind them." We may expect the French, who are the dominant European race in this quarter, to add considerably to our knowledge of these remains, and to clear up the mystery which lies around them. Indeed, the late unfortunate Lieut. Garnier, in his "Travels in Indo-China," has both with pen and pencil shed much new light on the subject.

To those who don't know much about Formosa and its strange inhabitants, savage and semi-civilised, Mr. Thomson's account of his tour in the island will be found of considerable interest. Appended is a list of the Diurnal Lepidoptera of Siam, collected by Mr. Thomson, and named by Mr. H. W. Bates, F.L.S. Altogether the book is a thoroughly creditable and, we believe, credible one, full of the most interesting information, and valuable for the considerable insight it gives into the life of

these Eastern Asiatics. The wood engravings, upwards of sixty, taken from the author's photographs and sketches, add much to the value of the volume.

### LETTERS TO THE EDITOR

[The Editor does not hold himself responsible for opinions expressed by his correspondents. Neither can he undertake to return, or to correspond with the writers of, rejected manuscripts. No notice is taken of anonymous communications.]

#### Hoffmeyer's Weather Charts

I HAVE the honour to inform you that the issue of Capt. Hoffmeyer's daily charts of the weather from 63° E. to 60° W. longitude, and from 30° to 75° N. latitude, for the three months of last winter, are now complete. (See NATURE of June 25, 1874).

Capt. Hoffmeyer is anxious to know what chance there is of his being able to continue the publication. The number of copies already sold of the existing charts has not been sufficient to cover the expenses of production.

At the same time this Office has found that the rate of subscription (11s. per quarter) which it charges has fallen short of the cost, carriage, and postage of the existing charts.

I have therefore to request any gentlemen who are willing to subscribe to a future issue of the charts to send in their names to me as soon as convenient. The rate of subscription will be at least 12s. 6d. per quarter, and must necessarily be higher if the original cost of the charts at Copenhagen is raised above the price first named, viz., 4 francs per month.

Meteorological Office, Jan. 12

ROBERT H. SCOTT

#### A New Bird of Paradise from the Island of Waigeou, near New Guinea

I GOT to-day from Ternate the skins (♂ and ♀) of a Bird of Paradise from Waigeou, which came through natives into the hands of Mr. van Mounhenbroek there, who recognised it to be an undescribed species. He proposes to call it *Diphyllodes Guilhelmi* iii., because no Bird of Paradise has yet been named after the King of the Netherlands, under whose sceptre the greater part of the region stands, where Birds of Paradise occur. It is known that two species from Australia are named respectively after the Queen of Great Britain and the Prince Consort, that three are named after naturalists, and that the others have names according to their external features. This new bird is highly interesting, because it stands in a conspicuous way between *Diphyllodes speciosa* and *Cicinnurus regius*, but more allied to the former, and at the same time bearing some characters of *Diphyllodes república*; therefore linking these species together in a similar way as it does *Paradisaea raggiana* (one of D'Alberti's discoveries) with *P. sanguinea*, *apoda* and *minor*. I shall soon send (in the name of Mr. van M.) the description of the new bird to the Zoological Society of London, and intend to publish a coloured figure as soon as possible. But knowing the lively interest English ornithologists take in new discoveries in the group of the *Paradisæide*, I thought it advisable to give a short notice in your journal beforehand.

Dresden, Jan. 9

A. B. MEYER

#### Chappell's "History of Music"

IN a review of my "History of Music," in NATURE, vol. xi. p. 123, your musical critic takes me to task for having cautioned English readers against certain new theories which are to be found in the works of the late F. J. Fétis and in the "Tonempfindungen" of Prof. Helmholtz. I think those cautions very necessary, and perhaps, when your critic has studied the subject, he may think so too; but in the meantime he bows down before such names, and cautions me that if Fétis were alive he "would not be in my shoes for a trifle."

I should rather object to change shoes with the critic, but I may remind him that he seems to have forgotten his obligations to the readers of NATURE. However diffident as to his qualification to controvert me, and therefore hoping for a second Fétis to arise, it was at least his duty to test each of us by the autho-

rities which we quote, and to inform your readers of the result. He must know that two such opposite accounts cannot both be true, and therefore either the one or the other is not trustworthy. Fétis and I differ *toto calo*, even to the scales. I had supposed that a few of the extracts which I have adduced from Fétis's own works would have spoken for themselves and have convinced anyone who professes critical knowledge that Fétis was a pretender, and that he was unable to understand the Greek treatises which he had before him. Your reviewer, however, is far too staunch-headed to be convinced, even though Fétis assumes to correct Aristoxenus in Greek, and Josephus in Hebrew.

My own conviction is unchanged by the second, third, and fourth volumes of Fétis's History. I find the same system of charging error upon others when he alone is in fault, and the same inability to understand the books before him. For instance, he had Kosegarten's translation of El Farabi's treatise on Persian, Greek, and Arab music, written at the beginning of the tenth century, but he could not discover from it that the Persians had then no thirds of tones in their scales. Neither did he find out that the Arabs had then emancipated themselves from the Greek minor scales, and had an excellent two-octave major scale, with perfect thirds in it, and a major seventh. It differed from ours, but rather for the better. These two points are most important in history, for in them we trace the comparative civilisation from which those nations have declined.

As to Helmholtz's new musical theories, your reviewer complains that I have described his book as "hasty," when "it is the result of eight years' labour." I think ill-considered conclusions may, in polite terms, be described as "hasty." Secondly, that I have said, "Some very necessary experiments, such as those upon harmonics, were omitted." I am quite of that opinion, for I differ with him as to the existence of "over-tones," and I adduce proof that harmonics are *subsequent* to the principal notes, and not simultaneous.

My arguments are before the world, and I have found them supported by others, including two of the very highest authorities. Until they can be rebutted, I have nothing to withdraw, but have much to add to them.

The "Tonempfindungen" is not a book which requires more than ordinary intellect to understand; therefore such deep discussion as that of your critic is not necessary. When Helmholtz informs his readers that thirty-three consonant vibrations between B and C cause the *dissonance* of that interval, he is literally telling them that white is black; and yet this critic would have us believe him.

WM. CHAPPELL

Stratford Lodge, Oatlands Park, Surrey

#### Origin of Bright Colouring in Animals

THOSE who are moderately well acquainted with Mr. Darwin's writings are not likely to feel that Mr. Murphy's criticisms (vol. xi. p. 148) upon them require any answer; but as many of your readers are probably not so well acquainted with these writings as they ought to be, I shall briefly expound the points raised.

1. Mr. Murphy himself admits that coloration *may* be as "variable within the limits of the same species" as is "any other part of the organism." In view of this fact, then, why is there any more difficulty in the way of our accepting sexual selection as a *vera causa*, than there is in the way of our accepting natural selection as such? Moreover, we must remember that animals have probably a much keener sense than we have of differences in form and colour among individuals of their own species.

2. Ornamental colouring is, as a rule, confined to the male, because, in Mr. Darwin's words, "the males of almost all animals have stronger passions than the females." I wonder that anyone can have read the "Descent of Man," and afterwards have asked the question to which this is the answer. Compare especially pp. 221, 222 (2nd edition).

3. I do not know on what "evidence" Mr. Murphy relies to "prove that the female is passive," in the sense of not exerting "any choice or power of selection whatever;" but I am quite sure that it must be something very great, if it is to neutralise the vast body of facts which Darwin adduces on the other side; for surely no one can doubt that "the elaborate manner in which the male birds and other animals display their charms before the female," is one of the strongest arguments we could desire to have "in favour of the belief that the females admire, or are excited by, the ornaments and colours displayed before

them." (*Ibid.* p. 541.) Mr. Murphy's assertion that his view of the case is "certainly supported by the very general fact of the males fighting for the possession of the females," makes against his argument if we consider another "very general fact," viz., that there is a sort of inverse proportion between pugnacity and coloration. For an answer to the next paragraph, compare "Descent of Man," pp. 225 and 226.

I do not know that I can quite agree even with your correspondent's closing paragraph. If we can imagine such a state of things as a colony of women left entirely to themselves, I think it is at least open to question whether their "love of dress and ornament" would not begin to decline.

A DISCIPLE OF DARWIN

"Ring Blackbird"

THE bird about which your correspondent C. M. Ingleby inquires is figured in most works on Ornithology as the Ring Ousel—is a local, not uncommon, but generally exceedingly shy bird. Through the late severe weather, however, and for a few days after the thaw, a cock bird has been a daily and very interesting visitor on my lawn. They are generally found on commons and in the neighbourhood of retired copses, and are only driven by stress of weather so near houses.

Bregner, Bournemouth, Jan. 9

HERVEY CECIL

[Another correspondent, F. B. Doveton, writes to the same effect, but states his belief that the Ring Ousel is only a summer visitant with us, his winter habitat being Southern Europe and Africa.—ED.]

THE NEW WESTERN CHINA EXPEDITION

WE are glad to learn that the Western China Expedition which left Rangoon in the middle of last month to reopen the old trade-route between Upper Burmah and Yunan, as we intimated a fortnight ago, has an efficient scientific staff attached to it. Col. Horace Browne is the commander of the expedition, and Mr. Ney Elias, Gold Medallist of the Royal Geographical Society and Assistant Political Resident at the Court of Mandalay, is the topographer. Dr. John Anderson, Director of the Imperial Museum at Calcutta, who was recalled from leave in England for the purpose, has been appointed medical officer and naturalist, and takes with him four collectors—two zoological and two botanical.

The expedition was provided at Calcutta with an efficient guard of fifteen Sikh soldiers, picked men from the fort, and two native doctors. At Rangoon they were to be joined by an Attaché of the British Embassy at Peking, and a Chinese interpreter. Another of the Peking Attachés, with an interpreter and guard, is to be despatched from Shanghai into the interior of China to meet them. These Attachés will be of the greatest use in keeping the expedition right as regards their intercourse with the Chinese officials. Dr. Anderson takes with him a fine photographic apparatus, which he will use himself. A considerable sum has been laid out in presents for the chiefs and other personages expected to be met with during the route; for the Viceroy of Yunan, two fine horses and a pair of kangaroo-hounds have been selected, and a large number of other appropriate objects.

The expedition is expected to be able to make its way from the upper waters of the Irrawaddy to those of the Yangtse-Kiang in the course of a few months, and will descend the latter river to the sea-coast of China. The Chinese Government has given every facility in the way of passports, so that there is every prospect of a successful result.

THE ACCLIMATISATION OF SALMON IN OTAGO

A RENEWED attempt is now being made to acclimatise the British salmon (*Salmo salar*) in New Zealand. The preliminary stages of the necessary operations have been carried out in Scotland, under the per-

sonal direction of Mr. Buckland, one of her Majesty's inspectors of salmon fisheries, and the ship, the *Timaru*, containing the precious freight, has sailed from the River Clyde, and is now, it is to be hoped, a far way on her voyage.

What has been done is as follows:—A quarter of a million of eggs have been taken from large, living salmon captured expressly for the purpose. These ova have been treated on what may be called the "piscicultural plan," that is, the eggs have been forcibly extruded from the fish in a vessel filled with water, by means of gentle pressure applied to the abdomen, from which they fall quite easily; after the ova are washed they are carefully impregnated with the milt of the male fish, and are then ready to be laid down on the hatching boxes. On the present occasion the eggs were brought from Perthshire, where they were obtained, chiefly from tributaries of the rivers Forth and Tay, to Glasgow, in order to undergo the process of packing for their long voyage. It is gratifying to know that only a very small portion of the eggs were spoiled while undergoing the process of being fecundated.

The plan adopted on the present occasion was to pack the ova on trays of perforated zinc, on which had been placed a thin layer of well-washed moss. The trays containing the precious ova were then arranged in a series of boxes, each of them a foot cube; these boxes will be carried to their destination in a cabin expressly built for them, paved with ice to the depth of about two feet, and having walls of ice three feet in thickness. A stratum of the same material is inserted between each box, so that the eggs during the passage of the *Timaru*, which may take a hundred days, will be kept at a very low temperature. Great pains have been taken in the packing of the eggs, and also as regards the disposition of the boxes in the ice-house, which will be hermetically sealed, and not be broken open till the ship is in port. It is an important circumstance in favour of this experiment that the eggs selected were all taken from fish which, judging by their dimensions, would be of considerable weight; not a few of them must have weighed over twenty-five pounds. They were not in the least injured during the process of compulsory deprivation of their eggs and milt, but when restored to the water went off quite lively, and as if they had enjoyed the process of artificial spawning.

The ship is expected to reach her destination, Bluff Harbour, New Zealand, about the end of March, at which date all the salmon eggs which she carries would, in the natural state, have become living fish, and, indeed, be a week or two old. The *Timaru*, as the time approaches for her arrival in New Zealand, will be anxiously watched for, and it is to be hoped that all the future stages of this important experiment will be as carefully gone about and as successfully accomplished as the initiatory operations.

The development of the ova whilst the ship is on her voyage will be largely prevented by the very low temperature which must result from the enormous quantity of ice that is in use. How far the rivers of New Zealand, seeing that upon the arrival of the eggs they will be at an autumnal temperature, may be suited for the ripening of the fish, has yet to be determined. We sincerely hope all the conditions will be favourable to the hatching and growth of the salmon. It will prove a singularly interesting task to trace the history of *Salmo salar*, so to say, from its creation, and to watch its progress from one stage of its life to another. We anticipate in the process the correction of many errors which have crept into the details of its natural history, so far as we know it at present.

The physical conditions of New Zealand have been depicted as being very similar to those of the old country; the resemblance will appear still more striking to emigrants when they see the finest fish of the old country leaping in its rivers.

ON THE EXISTENCE OF THE FALLOW DEER IN ENGLAND DURING PLEISTOCENE TIMES

MR. SCLATER'S translation of Dr. Jettelles' essay on the geographical distribution of the Fallow Deer in present and in past time (NATURE, vol. xi. p. 71), and the careful criticism which it has called forth on the part of Mr. Boyd Dawkins (*loc. cit.* p. 112), have renewed in my mind a conviction which I formed some years ago, namely, that *Cervus brownii* and *Cervus aama* are identical, and that under the former title the fact of the existence of the Fallow Deer in England during the Pleistocene period lies in some degree obscured.

The interest which, doubtless, Dr. Jettelles' essay has excited induces me to believe the present to be a fitting

occasion to endeavour to demonstrate the probability of this conviction. In his original description of *Cervus brownii* (Quart. Geol. Journ. 1868, p. 514), Mr. Boyd Dawkins thus writes:—

"The antlers of *Cervus brownii* are totally unlike those of any existing species excepting *Cervus dama*, to which they approach so closely that the type-specimen was considered by Dr. Falconer to belong to the latter. The basal half, indeed, so strongly resembles the corresponding portion of that of *Cervus dama* that it would be almost impossible to differentiate fragments from which the coronal portion had been broken away. But the resemblance ends at the second tyne (*c*). If the series of antlers of *Cervus brownii* be compared with those of the Fallow Deer which have been reproduced from Prof. Blasius's valuable work, there is this important difference

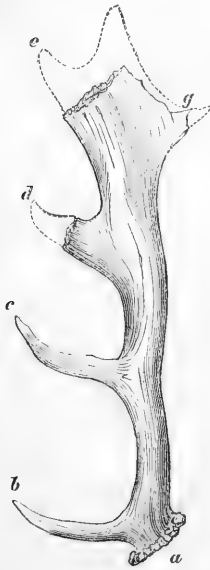

FIG. 1.—Type of *Cervus brownii*.

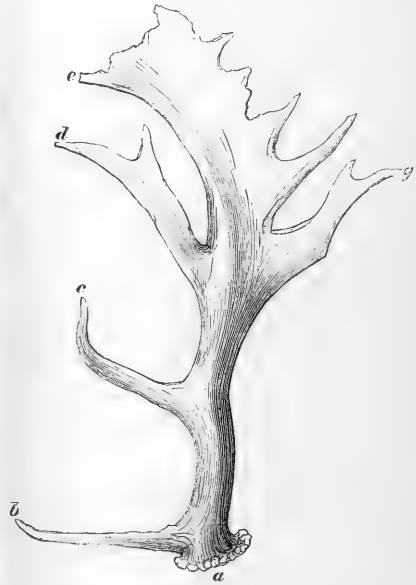

FIG. 2.—Right Horn of Wild Greek Fallow Deer.

visible: in the former the third tyne (*d*) is present on the anterior aspect, while in the latter it is altogether absent. With this exception the antlers of the two species are most closely allied; and Pl. xvii. Fig. 4 corresponds almost exactly with Pl. xviii. Fig 5, the third of the series of antlers selected by Prof. Blasius as typical of *Cervus dama*. To the objection that the development of the third anterior tyne may have been an accident, it may be answered that it is to be found in none of the endless variations of form assumed by the antlers of the Fallow Deer, and that it is presented also by a far more ancient cervine species from the crag of Norwich."

It is therefore clear that in its possession of the third tyne (*d*) is centred, according to Mr. Boyd Dawkins, the Clacton Deer's sole right to be considered specifically distinct from the common Fallow Deer. The accompanying drawings (Figs. 1—4) will, I think, be found to show the insufficiency of this character. Fig. 2 represents a horn of the wild Fallow Deer from Greece; Fig. 3 that of a

wild Fallow Deer from Sardinia. In both of these specimens the third tyne (*d*) will be seen to be largely developed. These horns are selected from a considerable series brought to me by my brother, Mr. Basil Brooke, direct from Greece and Sardinia, and in none of the other specimens is this tyne developed, but in all the anterior aspect of the horn resembles ordinary specimens of the horns of *Cervus dama*, such as those reproduced by Mr. Boyd Dawkins from Prof. Blasius's work. Fig. 4 illustrates still further the instability of the foundation upon which is based the specific separation of *Cervus brownii*. The horn here figured belonged to a deer which lived and died in one of my own parks. The third tyne (*d*), so distinctly shown in the figure, was produced but once in the course of the animal's lifetime, neither its companion horn nor those which preceded or succeeded it showing the smallest trace of it.

It may be remarked that the tyne *d* in the type of *Cervus brownii* (Fig. 1) stands at a lower level in relation



to the greatest palmation of the horns, than is the case in the other three specimens. The explanation of this discrepancy is very simple. The former represents (as its own characters and a comparison of it with the remainder of the fragments with the species found at Clacton readily prove) a young animal, probably a buck of four years of age, whilst the other figures represent the horns of adult animals. In the immature Clacton Deer

the force expended in producing the abnormal tyné *d* well-nigh exhausted the supply at the command of a system fully occupied with the production of things more needful, namely, materials for the vigorous increase and consolidation of flesh and bone. Hence the long, attenuated palm, which probably ended very much in the manner in which Mr. Boyd Dawkins has restored it. Analogous instances of excess of growth in one direction,

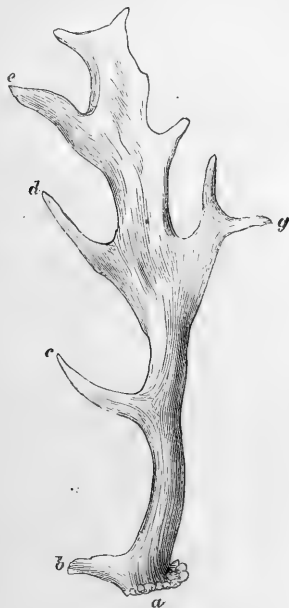

FIG. 3.—Right Horn of Wild Sardinian Fallow Deer.

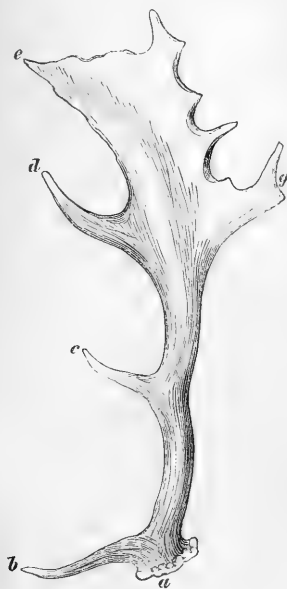

FIG. 4.—Right Horn of Park Fallow Deer.

causing a corresponding defect in another, may be seen in all large collections of deers' horns; indeed, in my own collection I find the horn of a young fallow buck, in which the characters specially alluded to in the type of *Cervus brownii* are shown in a still more marked degree.

These facts appear to me fully to justify the rejection of *Cervus brownii* as a species distinct from *Cervus dama*, and therefore to warrant the belief in the existence of this species in England during Pleistocene times. Whether the Fallow Deer became extinct in

Northern Europe before the advent of Prehistoric man, or whether it continued to exist in these islands even at the commencement of the Roman occupation, are questions which strike me as altogether beside that of the truth of the "ancient belief" to which Mr. Boyd Dawkins shows such firm allegiance. In either case, the species may have been reintroduced by the Romans, a people whose magnificently lavish expenditure upon luxury and pleasure despised bounds.

VICTOR BROOKE

#### HELMHOLTZ ON THE USE AND ABUSE OF THE DEDUCTIVE METHOD IN PHYSICAL SCIENCE\*

WE have still to speak of his attack on the authors of this book with regard to the omission theory of light. They say that such a theory is not to be justified unless a light-corpuscle has been actually seen and investigated. In this demand Mr. Zöllner detects "an impossibility which is not simply physical, but even logical, and which it is easy to expose. In fact, if the sensation of light is produced only when the corpuscles come in contact with our nerves, it is obviously impossible to have any ocular perception of such a corpuscle before it has touched or affected our nerves of sight." And then this remark is followed by declamation about gross blunders

\* Concluded from p. 151.

in logic, absolute nonsense, and so on. And, in fact, there is absolute nonsense here; only the nonsense does not lie in what the English writers have said, but in the interpretation which their opponent has put upon their words. Does a man who believes himself so superior to his antagonists in the firmness of his grasp of the principles of the theory of knowledge, still need to have it explained to him that to see an object means, according to the emission theory, to receive in the eye, and so to feel, the corpuscles of light that rebound from the object in question? But, this being so, there is no logical impossibility, and nothing inconsistent with the premises of the theory, in the supposition that a light-corpuscle at rest—and the corpuscles are at rest as soon as they are absorbed by dark bodies—may throw off other corpuscles that impinge on it, and so may become for these a centre of radiation, which will be visible as the radiant point. Whether such

a process can be brought under observation, and how this is to be effected, are, of course, questions which, on the argument of the English authors, fall to be answered by those who undertake the direct proof of the existence of the corpuscles. And whatever opinion one may form of the stringency and fitness of this demand, it involves no logical contradiction, which is the very point on which the argument must turn if Mr. Zöllner is to make good his case.

I will mention one other objection of similar scientific value, because it refers to Sir W. Thomson, though not to a passage of this book. The point in question is whether it is possible for organic germs to be present in meteoric stones, and so to be conveyed to worlds which have become cool. In his introductory address to the British Association at Edinburgh, in the autumn of 1871, Sir W. Thomson characterised this view as "not unscientific." Here, too, if an error has been committed, I must profess myself a sharer in it. I had, in fact, indicated the same view as a possible explanation of the transmission of organisms through interstellar spaces at a somewhat earlier date than Sir W. Thomson—in a lecture which was delivered at Heidelberg and at Cologne in the spring of the same year, but is still unpublished. If anyone chooses to regard this hypothesis as highly or even as extremely improbable, I have nothing to object. But if failure attends all our efforts to obtain a generation of organisms from lifeless matter, it seems to me a thoroughly correct scientific procedure to inquire whether there has ever been an origination of life, or whether it is not as old as matter, and whether its germs, borne from one world to another, have not been developed wherever they have found a favourable soil. The physical reasons alleged by Mr. Zöllner against the view in question are of very little weight. He points to the heating of the meteoric stones, and adds (p. 26): "Thus, even if we suppose that when the parent body was shattered, the meteoric stone covered with organisms escaped with a whole skin, and did not share the general rise of temperature, it was still necessary for it to pass through the terrestrial atmosphere before it could discharge its organisms to people the earth."

Now, in the first place, we know from oft-repeated observations that of the larger meteoric stones only the very surface is heated in passing through the atmosphere, the inner portions remaining cold, or even very cold. All germs, therefore, that happened to be in cracks of the stone would be protected from combustion in our atmosphere. But even germs lying on the surface would doubtless, when they entered the very highest and most attenuated strata of the earth's atmosphere, be blown away by the powerful current of the air long before the stone reached the denser parts of the gaseous mass, where the compression becomes great enough to generate considerable warmth. And on the other hand, with regard to the collision of two worlds as assumed by Thomson, the first consequences of such an event would be violent mechanical motions, while heat would be generated only in proportion as these motions were destroyed by friction. We do not know if this would last for hours, or days, or weeks. The fragments, therefore, projected in the first instant with planetary velocity might escape without any development of heat. I do not even think it impossible that a stone, or swarm of stones, flying through lofty strata of the atmosphere of a world might catch up and sweep along a quantity of air containing unburnt germs.

I have already said that I should not yet be willing to put forth all these possibilities as probabilities. They are only questions the existence and range of which must be kept in view, so that if opportunity offers they may be solved by actual observation or by inferences from such.

Mr. Zöllner then ascends to the two following propositions:—

"That scientific investigators in the present day

attach such extraordinary importance to inductive proof of *generatio æquivoca*, is the clearest mark of their lack of familiarity with the first principles of the theory of knowing."

And again:—

"In like manner the hypothesis of *generatio æquivoca* expresses . . . nothing else than the condition for the conceivable nature in accordance with the law of causality."

Here we have the genuine metaphysician. In view of a presumed necessity of thought, he looks down with an air of superiority on those who labour to investigate the facts. Has it already been forgotten how much mischief this procedure wrought in earlier stages of the development of the sciences? And what is the logical basis of this lofty standpoint? The correct alternative is clearly this:—

"Either organic life began to exist at some particular time, or it has existed from all eternity."

Mr. Zöllner simply omits the second of these alternatives, or thinks that he has set it aside by a passing reference brought in shortly before to certain physical considerations which are not in the least decisive. Accordingly his conclusion, which affirms the first of the alternatives above stated, is either not proved at all, or proved only by the aid of a minor resting on physical arguments (and, for that matter, inadequate physical arguments). The conclusion, therefore, is not in any sense, as Mr. Zöllner believes, a proposition of logical necessity, but at most an uncertain inference from physical considerations.

This is what Mr. Zöllner has to object to the authors of this handbook in the sphere of scientific questions.\* Mr. Zöllner's book contains a great number of other accusations of precisely the same value directed against other scientific investigators, with the same confidence in his own infallibility and the same rash haste in passing judgment on the intellectual and moral qualities of his antagonist. Another opportunity will present itself for the discussion of another part of these cases. If I may draw by anticipation a moral interesting to us in the present connection, I would say that no theoretical arguments can present to the attentive and judicious reader a stronger and more eloquent justification of the strict discipline of the inductive method, the loyal adhesion to facts which has made science great, than is supplied by the practical example of the consequences of the opposite, would-be deductive, or speculative method given in Zöllner's book; and this all the more that Mr. Zöllner is beyond question a man of talent and knowledge, who did most promising work before he fell into metaphysics, and even now shows acuteness and the faculty of invention whenever he is limited to the field of the actual, e.g. in the construction of optical instruments and the devising of optical methods.

#### NEW ZEALAND PLANTS SUITABLE FOR PAPER-MAKING

THE utilisation of waste materials for paper-making is a subject upon which a great deal has been said and still remains to be said and done. In every country waste vegetable matter which contains fibre in anything like suitable proportions is sure to attract much attention. The subject has been handled in various works, directly or indirectly, in this country as well as on the Continent; and with regard to Australian plants suitable for paper-making, Baron Mueller, of Melbourne, issued a lengthy treatise in connection with a series of specimens of paper actually made from the plants enumerated and exhibited in the Paris Exhibition of 1867. We have now before us a paper by Mr. T. Kirk, F.L.S., of Wellington, on

\* In the region of personal questions, and with reference to the claim of priority as to the principles of spectral analysis made by Sir W. Thomson for Mr. Stokes against Mr. Kirchhoff, I must side with the latter, fully agreeing with the reasons which he has himself brought forward.

some indigenous materials of New Zealand suitable for the manufacture of paper. The plants enumerated occur in great abundance in different parts of the colony, and, it is said, are being yearly destroyed to an enormous extent by the progress of settlement. Most of the plants alluded to in this paper belong to the endogenous group, Liliaceæ and Cyperaceæ being the chief natural orders. In the genus *Astelia* a group of small tufted sedge-like plants belonging to the first-named order, five species of which are described as occurring in New Zealand, four are recommended, both on account of the quantity of fibre contained in their leaves, as well as for the abundance with which the plants grow. *A. Solandri*, the Tree-flax of the colonists, is a plant with numerous radical leaves, from one to two feet long, thickly clothed at the base with shaggy silky hairs, and containing a quantity of good fibre. It is abundant on lofty trees and rocks throughout the colony, resembling in the distance the nest of some large bird. "Hundreds of tons" of this plant, it is said, "are destroyed on every acre of forest-land cleared in the North Island."

*A. Banksii* and *A. Cunninghamii*, both of which have a similar habit to the first-named species, but with narrower and much longer leaves, sometimes from three to six feet in length, produce a superior fibre. The first is found in great abundance in wooded places near the sea, and the latter is common on trees and rocks. Both are abundant in the North Island, "but their southern distribution is uncertain."

A species of *Astelia*, known as the Kauri Grass, and called by Mr. Kirk *A. trinervis*, is said to be "the most abundant of all the species, occasionally forming the chief part of the undergrowth in the northern forests up to 3,000 ft., and so dense that it is often difficult to force one's way amongst the interlaced leaves, which are from three to eight feet long, and of a paler green tinge than either of the preceding. It could be procured by hundreds of tons, and as, like other species, it is found in situations not adapted for ordinary cultivated crops, a permanent supply might be fairly calculated upon. Experience has shown that it may be cut yearly."

In the allied genus *Cordylina*, which is composed of shrubby or small palm-like trees, the *Ti*, or cabbage-tree (*C. australis*), is the most important. It attains the greatest height of any of the New Zealand species, averaging from ten to twenty or even thirty feet, and producing a trunk usually from ten to eighteen inches in diameter, but sometimes even three feet across. The plant is very abundant in many districts, and the leaves contain a very large quantity of fibre. *C. Banksii*, a smaller growing species, with a trunk from five to ten feet high, produces a fibre of superior quality, but less abundant; the plant, however, is very plentiful on the margins of forests, gullies, &c., all over the North Island, and in the northern parts of the South Island.

That the leaves of the *Cordylines* are suitable for paper-making there can be no doubt. In appearance, when dry, they very much resemble the so-called palmetto leaves which have recently been brought into this country from America for the purpose of competing with esparto. These palmetto leaves are those of one or more species of *Chamærops*, perhaps *C. serrulata*, which is known in some parts of the Southern States as the Saw Palmetto. The leaves of *Cordylina australis* are not altogether unknown in Europe as a paper material, for it appears that some years since a quantity was sent to England from New Zealand specially for trial, and were made into paper at a mill in Yorkshire: at that time the leaves were highly recommended for the manufacture of a superior kind of paper. A leaf somewhat similar, but generally of softer texture, is that of the genus *Freyinetia*. *F. Banksii*, known as the New Zealand Screw Pine, is abundant in most woods, and it is said that the leaves might be procured by thousands of tons. *Gahnia setifolia*, which is abundant in

both islands and capable of being procured in almost unlimited quantity, is recommended for the manufacture of coarse paper. The *Gahnias* are a group of tall-growing, coarse, rigid cyperaceous plants, with long, harsh, cutting leaves, from which fact the plants are known in some parts of the colony as "cutting grasses." The genus is distributed through New Zealand, Australia, Tasmania, the Malayan and Pacific Islands.

The large order Composite, containing as it does such a variety of plants, from trees down to shrubs and herbs, might be expected to include many whose woolly foliage would prove useful for paper-making. The genus *Celmisia*, however, is the only one mentioned in the paper under consideration; the species are perennial bulbs, with radical, rosulate, simple leaves, mostly covered with a white or buff-coloured tomentum, which gives them a leathery texture, and hence the plants are called Leather-plants, or Cotton-grass. The commonest species in the islands is *C. longifolia*, which ascends to an elevation of 5,500 feet, and varies much in height, length, and breadth of leaves, as well as in general robustness. *C. verbascifolia* is a fine species, with broad coriaceous leaves averaging from four to eight inches long, but, according to Mr. Kirk, growing sometimes to a length of two feet. *C. coriacea* is likewise an abundant species, with thick leaves from ten to eighteen inches long, and from half an inch to two-and-a-half inches broad, covered on their upper surface with matted silvery hairs, and on the other with thick silvery tomentum. These leaves are said to make a good paper material; it is certain that when dry they are very tough, and the natives make them into strong and durable cloaks.

The plants here enumerated are only a few of those considered likely to prove valuable in the colony for paper material; they are selected because of their being little or perhaps not at all known for economic uses. Such well-known plants as the New Zealand Flax (*Phormium tenax*) are passed by with a simple mention of the fact that a company has recently been formed in Auckland, specially for utilising its fibre in the manufacture of paper.

While on the subject it may not be quite out of place to mention, in reference to the notice on the use of *Zizania aquatica*, in NATURE, vol. xi. p. 33, that several of the North American daily papers, as the *New York Tribune*, *Montreal Gazette*, &c., are printed on paper made entirely from this plant, and that the promoters of its use in England propose to bring it to this country in the form of half-stuff, to save expense of freight.

JOHN R. JACKSON

#### A FRENCH OFFICIAL ACCOUNT OF THE ORIGIN OF THE ROYAL SOCIETY

WE find in the first volume of the "Memoirs of the French Academy" a few curious details relating to this subject which may be of some interest to our readers. We translate the text *verbatim*, with the addition of a few explanatory remarks. These details were originally published in Latin, by the first perpetual secretary of the Academy, and may therefore be considered as official.

"Full fifty years had elapsed (in 1666) since the learned men who lived in Paris began to meet at the abode of Father Mersenne, who was the friend of the most learned men in Europe, and was pleased to be the centre of their mutual visits.\* MM. Gassendi, Descartes, Hobbes, Roberval, Pascal (father and son), Blondel, and some others met at this place (close to the Place Royale, in a convent). The assemblies were more regularly held at M. de Montmort's, Master of Request in Parliament (and

\* Father Mersenne was the intimate friend of Descartes, and his philosophical propagandist. It was not deemed prudent by the writer to mention Descartes' name, except as coupled with others.

editor of Gassendi's works\*), and afterwards at M. Thevenot's.† A few foreign visitors to Paris were present at these meetings. . . . It is possible that these Paris assemblies have given birth to several Academies in the rest of Europe. However, it is certain that the English gentlemen who created the Royal Society had travelled in France, and had visited at Montmort's and Thevenot's.

"When they were again in England they held meetings at Oxford, and kept on practising the exercises to which they had been accustomed in France. The rule of Cromwell was beneficial to these meetings. These English gentlemen, secretly attached to their legitimate lord, and unwilling to take any part in public affairs, were very glad to find an occupation which would give them an opportunity of living far from London without being suspected by the Protector. The Society remained in this state up to the time when Charles II., having resumed the kingly office, brought it to London, confirmed it by his regal power, and gave it privileges. So Charles II. rewarded the sciences which had lent an easy pretext for keeping the faith towards him."

The narrative explains that the creation of the Royal Society was an example given to Louis XIV. for establishing his Academy of Sciences.

### THE TRANSIT OF VENUS

SINCE our last notice of the Transit observations, a letter, dated Mauritius, Dec. 10, has been received by the Astronomer Royal from Lord Lindsay, containing a detailed account of the results he obtained. Besides, a brief statement of the observations of Mr. Meldrum, the Director of the Government Observatory, Mauritius, has appeared in the *Times*, with news from other observers, which, with its comments upon them, we reproduce in a condensed form.

Mr. Meldrum, with a perfect telescope of six inches aperture, by Cooke, of York, has been fortunate enough to obtain an observation of the ingress, although both Lord Lindsay and the German party were prevented from doing this by the cloudy state of the sky. But, although Mr. Meldrum obtained the two interior contacts, clouds and haze were at intervals passing over the sun, which, in fact, was obscured during the greater part of the transit. At times, beautiful definitions of the planet were noted, especially soon after the first interior contact. Then there was a long period of obscuration, after which, most fortunately, the sun shone out for the second interior contact. Only the first exterior contact was lost, the sun not appearing at all until 6h. 16m. A few minutes before the last exterior contact the sun was again obscured, and when the clouds passed away the transit was over.

Lord Lindsay states that his expedition has been in a great measure successful. The morning of the 9th was cloudy before sunrise, and for a short time afterwards. The first external and first internal contacts were missed from this cause; the sun was not seen until 1h. 2m. after the first external contact, when it came out for a few minutes, when photographs and measures were obtained. It was not till 8 A.M. (local mean time) that it became fairly fine, and remained so with small periods of cloud obscuration until the end of the transit. Lord Lindsay took 271 plates, out of which number, perhaps, 110 will be of value. One of his photographs shows the second internal contact beautifully.

With the heliometer, Mr. Gill obtained five complete determinations of greatest and least distance of the centres

\* Montmort for years entertained Gassendi in his house. He was a very valued *bibliophile*, and all the books from his library now realise an immense value. He was a member of the Académie Française.

† Thevenot had travelled much, and was in constant correspondence with many travellers. He had been appointed librarian to the King, and lived the house where the library was kept, in what is now the Rue Vivienne, within a little distance of its present site.

of the sun and Venus, besides nine measures of cusps and two separate determinations of the diameter of Venus near the end of the transit. Dr. Copeland obtained, with the six-inch equatorial and Airy double-image micrometer, fifteen measures of least distance of Venus from the sun's limb, and ten measures of cusps. Dr. Copeland also observed the last internal and external contacts with this instrument. The last internal contact was observed with the four-inch equatorial and the polarising eye-piece by Mr. Gill. He also observed the last external contact with the heliometer. Both Dr. Copeland and Mr. Gill agree that the contacts of Venus and the sun are remarkably similar to those seen in the model. They also agree that any phenomena which could be classed under the head "black drop" took place and disappeared within a period of five seconds. All the photographic exposures are automatically registered on the chronograph by a method which gives the actual duration of the exposure. The heliometer observations were also registered there. Dr. Copeland observed by eye and ear; all other observations (photographic and heliometric) also observed by eye and ear as a check on the chronograph. The German expedition under Dr. Low got the third and fourth contacts, with three complete sets of heliometric measures.

With regard to the operations of the party sent out by the Government of Holland to Réunion, the further information shows that there, as at Mauritius, the ingress was missed altogether, in consequence of the bad weather. The second interior contact at egress was observed both by Dr. Oudemans and Dr. Soeters, not the least trace of the black drop being observed. Only nineteen plates could be exposed, and of these only two or three are considered of value. The observations with the heliometer were more successful. The party, instead of measuring the distance of the planet from the sun's edge along a radius, had calculated beforehand, for each ten minutes, the direction of the most favourable chord for determining the relative parallax of Venus; two sets of eight measures of this kind were recorded.

Some observations made at Colombo by Mr. George Wall, and communicated to the *Ceylon Times*, are of great interest, as here is again recorded an exact reproduction of the appearance observed by Chappe d'Aueroche in 1769. On this the *Times* remarks that it is clear that science will lose much from an incomplete discussion of all the observations made in 1761 and 1769. On this subject we also draw attention to the following letter which we have received from Mr. E. W. Pringle, dated Manantoddi, Wynaad, Dec. 13:—

"I make no apology for sending you a short account of the late transit as seen by me in Wynaad, especially as I feel some surprise at the difference between the expected and actual phenomena.

"Owing to non-receipt of instruments from England, I had to fall back on a small  $2\frac{1}{2}$ " refractor by Cooke, of York, the definition of which is superb, even with a power of 53—that used on the occasion.

"My station was on a hill nine miles from Manantoddi, about 800' above that place and 3,600' above sea-level.

"The morning of the 9th was simply perfect; not a breath of air, and not a cloud, with the exception of a wispy or two of cirrus that the sun soon shook off.

"The plateau beneath was wrapped in the fleecy mantle that proved so disastrous to the eclipse observers of 1871, but this I could afford to despise from my more lofty station.

"I missed first external contact, and watched anxiously for the internal contact. When the planet was about half immersed, the entire disc became visible, for the portion external to the solar surface was surrounded by a fine silvery ring like a minute corona. This observation was verified by my brother, and the phenomenon was again visible at emersion.

"As first internal contact approached I looked carefully for the 'black drop,' but, to my astonishment, the horns of the sun grew nearer and nearer, and at last seemed to fade into the last portion of the before-mentioned silvery ring, without my seeing the smallest vestige of the far-famed 'drop,' or any apparent

elongation of the limb of the planet. Had it existed to the extent of one hundredth of the diameter of Venus, I am confident I should have seen it.

"At last external contact I fancied that the limb of the sun at point of contact was broken more rapidly than it should be, but if there was a 'bead' it was a very minute one.

"At first internal contact, in spite of the low altitude of the sun, the definition of the perimeters of both it and the planet was excellent; but at last internal contact, owing to the great heat and a strong land breeze, there was some amount of atmospheric interference.

"The time of the transit was taken with an ordinary watch, a good goer, and I hope to be able to fix the position of the station before long, although such observations here must of course be of very secondary consideration.

"During the transit I tried to obtain absorption bands from the atmosphere of the planet, but failed, owing to insufficient power and the difficulty of keeping the slit of the stellar spectroscope used, on the planet, with altazimuth motion.

"I may mention that on the evening of the 9th there was a fair display of parhelia, just at sunset. The sky was then covered with delicate bands of cirrocumulus."

#### ON THE AGE OF AMERICAN STONE IMPLEMENTS, OR "INDIAN RELICS"

THE interest connected with the various forms of ordinary stone implements, of which arrow-heads are by far the most abundant form, is greatly lessened by the fact that nothing connected with their discovery bears upon the question of the date of their origin. We know about the date of the introduction of iron, by European visitors to our country, and therefore about the time of the abandonment of stone implements and weapons by the Red men; but concerning the time of the commencement of the use of stone here in the States we are almost wholly in the dark.

Having, during the past three years, had unusually favourable opportunities for collecting the various types of relics from a locality extraordinarily rich in them, we have endeavoured to learn something concerning the date of their origin by studying them *en masse* and *in situ*, as in this manner they at least suggest probabilities, which isolated specimens, gathered from numerous and distant localities, would never do. During the past three years we have gathered and carefully examined, as they were taken from the soil, over nine thousand stone implements, embracing fully nineteen twentieths of the forms described by Mr. John Evans in his "Ancient Stone Implements of Great Britain," and some twenty forms of weapons and household implements not mentioned in his work.

The result of the examination of this enormous collection of specimens on the spot where they were found, has been to convince us that the ruder forms, usually of slaty rock and other minerals softer than flint, are older, as a rule, than the beautiful jasper specimens found immediately above them. No such conclusions could be arrived at from merely examining these same specimens in a cabinet, and if these ruder and more elaborate forms were intimately associated in the soil, it would be difficult to dissociate them; but taking the history of the discovery of each specimen separately, we find that just in proportion as these relics are rude in manufacture and primitive in type, they are more deeply embedded in the soil. We have never met with a jasper (flint) arrow-head in or below an undisturbed stratum of sand or gravel, and we have but seldom met with a rude implement of the general character of European drift implements on the surface of the ground; and when such specimens did occur, there were generally some indications of unusually deep disturbance of the surface of the ground. Indeed, it is in fact just what it should be in theory, *i.e.*, the older forms are found alone, and at considerable depths below the surface; the newer and latest types found only at the surface, except when in graves, and associated with these

a few specimens of the more archaic forms; just as we now in our own time see, in some isolated localities, household implements still in use, that, as a rule, have been discarded for better forms for more than a century. We repeat, that the conclusions arrived at by us we claim to be warranted by the fact of their applying to the collection of over nine thousand specimens gathered by us from a limited locality, and examined at the time of their discovery with special reference to the relationship the rude and elaborate forms bore to each other.

The belief here expressed with reference to the relationship of rude and elaborate relics is in accord with the division of the Stone Age into a Paleolithic and a Neolithic era; inasmuch as no indication of a *polish* has been found on any of the rude relics gathered by us; and polished celts and grooved axes with well-ground blades, or edges, occur only on the surface or in graves. It may be well to state here that by the phrase "on the surface" we mean on or in the soil that is now in cultivation. Relics that are upturned by the plough are considered as being "on the surface,"—beneath the surface being the stratum underlying the cultivated soil, and so beyond the reach of the ploughshare.

When and how the Atlantic coast of North America became peopled by the Red men cannot be determined by these same relics; but that that event should have been comparatively recent, and that such rude relics as we now find deeply embedded in the earth, and the magnificently wrought agate and jasper spears, and polished porphyry and hematite celts, should have been in use at the same time and by the same people, is simply incredible. We cannot now go into the full details of all the points of interest connected with our discoveries, but offer with confidence to students of American archaeology this fact, that the paleolithic relics are immensely older than the elaborately worked surface-found forms. This fact, we believe, is a powerful support to the theory (if, indeed, it needs further demonstration) of the gradual development of man from the condition we call savagery.

CHARLES C. ABBOTT

Prospect Hill, Trenton, N. J., U. S. A.

#### NOTES

THE invitation addressed by the King of Siam to the Royal and the Astronomical Societies ought to be gratifying to scientific men in more ways than one; it is one more evidence of the spread of a respect for science, and of an idea, however vague, of its high value. The letters amount, indeed, as the *Times* remarks, to the offer of a large subsidy on the part of the King, and are no empty compliment. They indicate in the clearest manner the effect which the steady prosecution of inquiries by the most civilised is having in the less civilised countries; an effect of an important kind, which it would be difficult to arrive at in any other peaceful way. The following is the text of the King's letter to the Astronomical Society:—"The Royal Palace, Bangkok, Oct. 9, 1874.—My dear Sir, I have much pleasure in informing you that I have received the commands of his Majesty to request you to inform the Royal Astronomical Society that if it will appoint men of science to observe the total eclipse of April next, his Majesty will be happy to consider them as his private guests during their visit, and will take on himself their entertainment and provide them with transport for themselves and their instruments from Bangkok to the station selected by them and back again, and will erect such temporary buildings as are required for them and their assistants. A communication to this effect will be made by his Excellency the Minister for Foreign Affairs to the Acting British Consul-General here; but as this will be slow in reaching the gentleman interested, his Majesty has commanded me to address this note to you to communicate it to the Society as soon as possible. I shall be most happy to

receive any communication from the Secretary of the Society named; and if any gentlemen propose to avail themselves of his Majesty's invitation, I should wish to receive particulars of the probable number of the party or parties, of the station or stations proposed, and the foundations required for instruments—a plan, in fact, for each intended observatory, that I may submit them for his Majesty's orders. You may state that our topographer, Capt. Loftus, and other officers who, as surveyors, are accustomed to precise observations, will be happy to assist if desired, and his Majesty will willingly release them from their other duties for this purpose. With the assurance of my high esteem, believe me, my dear sir, your most faithful friend, DIASHA-KARAWONGSE, H.S.M. Private Secretary."

THE great solar eclipse of 1868 was visible in Siam, as the 1875 eclipse will be. The then reigning Siamese king had not invited any European astronomer; but the French Government sent an expedition, who located themselves in Malacca for the purpose of taking spectroscopic observations. The King of Siam, who professed to be an astronomer, came with a royal train and a large army to observe the sun and perhaps the sun-observers. The observations were very successful indeed; but the French astronomers had located themselves on marshy land and were almost all attacked by fever, of which they were cured only on their return to France. Such was not the case, however, with their royal guest, who was also attacked, and died a few months afterwards.

A TELEGRAM, dated Hong Kong, January 9, states that the *Challenger* has left that place in continuation of her cruise.

WE are informed that a subscription list has been opened in Stockholm for the purpose of erecting a monument to Scheele, whose discoveries gave such a powerful impulse to the advancement of chemical science in the eighteenth century.

It is also reported that there is a probability of a monument being erected in Brussels in honour of the late M. Adolphe Quetelet, the well-known Secretary of the Belgian Academy.

A NEW section of the Glasgow Philosophical Society—Section C, Physics (including Mechanics and Engineering)—has been formed, with Jas. R. Napier, F.R.S., as president, Prof. Sir Wm. Thomson, LL.D., F.R.S., and Prof. R. Grant, LL.D., F.R.S., as vice-presidents, and Thos. Muir, M.A., F.R.S.E., as secretary, and has already begun to do good work in the cause of original research. The success of this section, along with that of the recently organised Science Lectures Association, affords good evidence that in Glasgow, as elsewhere, there is a significant stirring among the dry bones from which we may hope for valuable results in the not distant future.

THE January number of Petermann's *Mittheilungen* contains a letter from Dr. Nachtigal, who has done for the eastern countries of the Sahara and Soudan what Barth did for the central, telling of his return to Cairo after an absence of about six years. He was received by the Viceroy and the German inhabitants of Cairo with the greatest honour. As his health has been considerably impaired by the hardships he has had to undergo, he intended to stay some time in the genial climate of Egypt to recruit, not caring to plunge suddenly into the rigours of a northern climate. Dr. Petermann gives a brief *résumé* of the course of Dr. Nachtigal's journeys.

THE scheme which was proposed about a year ago for the erection of an aquarium, to be built on the beach at Hastings, has been revived, and we are informed that a limited liability company, composed of local capitalists, has been started for the purpose of carrying out the project. The building will be erected a little to the east of the present pier, and one of the two designs to which premiums were awarded last year will probably be adopted.

FROM a previously undisturbed deposit on Funk Island, a guano-covered rock to the east of Newfoundland, several bones of the Great Auk (*Alca impennis*) have been recently brought to this country. They are not in a first-rate state of preservation, being considerably injured by exposure.

THE Marquis of Bute has recently purchased eight Canadian Beavers, seven of which have arrived safely in the Island of Bute, and have been placed in the enclosure constructed for the four which died some time ago on Drumreoch Moor. To increase the chance of their acclimatisation, the animals will be supplied with a certain amount of food for some time to come.

FROM a report of a journey into the interior of Formosa made in the latter part of the year 1873, we learn that the flat portion of the country is almost everywhere cultivated with the greatest care: the principal crops are rice, sugar-cane, and sweet potatoes; and the minor crops, pea-nuts (*Arachis hypogaea*), indigo, and *Arca palus*. The mountain region, though very steep and rugged, was covered with thick tropical forest. Tree-ferns, as well as other ferns, grew luxuriantly; and in places where there was a bit of level ground, Chinese had formed settlements around which they were growing rice, and were clearing patches of the hill-sides for the cultivation of tea. Formosa is the island from whence we obtain our supplies of the camphor of commerce, but in the interior the trees which abound in the forests are said to be left untouched, as the natives do not know how to make camphor.

THE cultivation of cocoa (*Theobroma cacao*) is being largely extended in Guayaquil. New plantations have been found, and new trees planted on the old estates, so that the average yield will be greatly increased. The crop of 1873 was the largest yield known for many years. Another of the chief products of Guayaquil is indiarubber, or caoutchouc, the yield of which has very much decreased of late, owing to the custom of destroying the trees to collect the gum, so that it has become necessary to go further into the forests in search of the trees, which, together with the increased difficulty of transport, has added much to its first cost.

ONE of the large Blue Gum Trees (*Eucalyptus globulus*) in the Temperate house at Kew is now showing bunches of fruit. These fruits are from three-quarters to an inch in diameter, and are peculiar on account of their hard woody nature, being nearly enclosed by the ligneous calyx, and opening at the apex by valves corresponding in number with the cells.

AMONGST economic plants of interest at present flowering at Kew, the Tea-plant and the Star Anise claim notice. A fine bunch of the Black Tea (*Thea chinensis*), var. *Bohea*, cannot fail to attract attention in the Temperate house at this season, where flowers in general are scarce. Though the genus *Thea* is so closely allied to that of *Camellia*, its flowers are comparatively inconspicuous when compared with those of the well-known *C. japonica*. The large yellow anthers, however, redeem it from insignificance. The Star Anise (*Illicium anisatum*), which find a home in the Economic house, is a native of South-west China, growing to a height of about fifteen feet. The common name of Star Anise is derived from the stellate form of the fruit when ripe, and its odour somewhat resembling that of aniseed. Large quantities of these fruits, with the seeds in them, are exported from China to Europe and India. On the Continent they are largely used to flavour spirits, but with us their chief use is for expressing an essential oil, which is frequently sold for real oil of aniseed.

THE differences between the organisation of the French Academy of Sciences and the Royal Society are striking. Any-one wishing to become a French Academician is obliged to visit each of the electors and to ask personally for their suffrages.

The number of French Academicians is strictly limited, and no new member is appointed except to fill a vacancy. There is a special section open to members who may have no sufficient scientific qualifications; they are called *Académiciens libres*, and belong to no special section, but cannot vote in the election of members, and are not paid.

EXPERIMENTS have been tried on some French railways for warming passenger cars by a stove, which is placed outside. It is said a single stove is sufficient for a whole car, and the expense is very small indeed, twenty-six pounds of coal keeping up the fire for about 200 miles. The warmed air circulates inside the car.

ATTENTION has been drawn in France by the news of the burning of the *Cospatrick* to the proper means for extinguishing fire on board ships. M. de Parville advocates in the *Débats* the obligatory use of signal-thermometers in the hold; each elevation of temperature being notified by the ringing of an electric bell. Others advocate the use of extinguishers. These are large bottles full of compressed carbonic acid, which may be of immense use in limited spaces, perhaps more valuable than water.

WE notice to-day the sailing of the *Tinaru*, from Glasgow, with a consignment of salmon eggs for Otago, New Zealand. The ship *Tintern Abbey* has also recently sailed for New Zealand, having on board no less than 1,130 living birds, viz., black-birds (*Turdus merula*), thrushes (*Turdus musicus*), starlings (*Sturnus vulgaris*), redpoles (*Linota rufescens*), of each 100; hedge-sparrows (*Accentor modularis*), 150; linnets (*Linota cannabina*), 140; goldfinches (*Fringilla carduelis*), 160; yellow-hammers (*Emberiza citrinella*), 170; and, lastly, partridges (*Pardix cinerea*), 110. When the birds arrive in New Zealand they will be let fly under proper authority. There is, we understand, a heavy penalty enforced against shooting at or injuring these birds in New Zealand, and it is hoped that they will do well at the Antipodes. The New Zealand farmers cannot get on without them, for they keep down the insects that ravage the crops. The Acclimatisation Society of Canterbury, New Zealand, we understand, have begun and are now persevering in this good public work.

THE weather has been extraordinarily warm and genial in Paris, as in London, and in the whole of France, for some days, but almost all the rivers have been swollen to a dangerous height owing to the rapid melting of immense quantities of snow. Disasters have been experienced along the banks of many streams, principally the Rhone. At Lyons the disasters were increased by a stockade or *barrage* erected suddenly across the stream. All the ice collected and produced an immense iceberg at a point called Ile Barbe. It was feared for a while that this stupendous mass of ice would force its way above the stockade and destroy everything below, and great efforts were made unsuccessfully to get rid of it. But the continuance of the genial temperature has gradually destroyed the obstruction. Never was the theory of regelation, as propounded by Tyndall, submitted to the test of a larger experiment.

MESSRS. H. S. KING and Co. have in the press, and nearly ready for publication, the following works relating to science:—“Mankind: a Scientific Study of the Races and Distribution of Man,” considered in their bodily variations, languages, occupations, and religions, by Dr. Peschel.—Translations of two new works by Prof. Ernst Hæckel: viz., “The History of Creation,” edited by E. Ray Lankester, M.A. This book will be illustrated by coloured plates and genealogical trees of the various groups of both plants and animals.—“The History of the Evolution of Man,” translated by E. A. Van Rbyn and L. Elsberg, M.D., with various notes and other additions sanctioned by Dr. Hæckel. Also the following new

volumes of their International Scientific Series:—“Fungi;” their nature, influences, uses, &c., by M. Cook, M.A., LL.D., edited by the Rev. M. J. Berkeley, M.A., F.L.S. “The Chemical Effects of Light and Photography in their application to Art, Science, and Industry,” by Dr. Hermann Vogel, of Berlin; and a treatise on “Optics,” by Prof. Lommel, of the University of Erlangen. These three books will be profusely illustrated.

MESSRS. SMITH, ELDER, and Co. will publish, in a few days, a work called “The Cremation of the Dead,” by Mr. William Eassie, C.E., who is well known for his work in sanitary matters.

THE cultivation of oysters has been attempted by the United States Commission of Fisheries in the Great Salt Lake of Utah, where numbers of these bivalves from California have been placed with the view of testing the possibility of their thriving there. Some beds were choked by mud brought down some small streams, but in other parts the oysters promise to succeed. Shad have also been placed in the lake and have been seen in good health, and a lot of salmon fry from the Sacramento, artificially hatched out, have been placed in the Jordan and other rivers running into the Great Salt Lake. So far, in the fresh waters, they have done well, and at ten months old were from four to six inches long. It remains to be seen whether they will thrive as well in the salt waters of the lake as in the sea itself. The experiment is a most interesting one, and opens up some curious questions in the natural history of the salmon and the other fish under experiment.

THE Council of the Society of Arts have passed a resolution to the effect that it is desirable that the Cantor Lectures programme be from time to time, as far as may be found practicable, arranged to further the scheme of the Society's Technological Examinations, and that steps be taken for getting such lectures published in a special form as guide-books.

THE third number has been sent us of the *Journal* of the Society for the Promotion of Scientific Industry, whose headquarters is at Manchester. The *Journal*, which is of considerable size, contains reports of the meetings of the Society, at which a number of good practical papers have been read. One of the most scientifically important of these is on “The Chemistry of Calico Printing and Dyeing,” by Mr. Charles Dreyfus.

WE have received from the author, M. E. Maily, a very interesting “Essai sur la Vie et les Ouvrages de M. L. A. J. Quetelet,” poet, *littérateur*, geometer, physicist, astronomer, and statistician, doubtless one of the most remarkable men Belgium has produced. As we gave some account of M. Quetelet's life and work shortly after his death, we need not further notice M. Maily's book, which we recommend to all who desire to know further about this notable man. The publisher is Hayez, of Brussels.

WE are glad to see that Mr. J. E. Taylor's lectures in Ipswich on “Plants, their Structure, and their Uses,” have been so successful that it has been found necessary to engage a larger hall than that in which the course was begun.

THE *Bulletin* of the Minnesota Academy of Natural Sciences for 1874 contains a report on the birds and a list of the *manuals* of Minnesota. There are also geological notes from early explorers in the Minnesota Valley, arranged by Mr. N. H. Winchell.

“THE Safe Use of Steam, containing Rules for the Guidance of unprofessional Steam Users,” by an Engineer, seems a book likely to be of practical use to many persons. It is published by Lockwood and Co.



MR. L. SCHWENDLER sends us two papers by him: "On Earth Currents," reprinted from the *Proceedings of the Asiatic Society of Bengal*; and "On the General Theory of Duplex Telegraphy," from the *Journal of the same Society*.

"NOTES on a Till or Boulder Clay with Broken Shells, in the lower valley of the River Endrick, near Loch Lomond, and its relation to certain other Glacial Deposits," is the title of a paper by Mr. R. L. Jack, F.G.S., reprinted from the *Transactions of the Geological Society of Glasgow*.

UNDER the title of "Report of the Government Botanist for the year ending June 30, 1874," Baron von Mueller, of Melbourne, has given a *résumé* of the scientific work of the year, carried on by him or under his immediate supervision. In the first place, Baron Mueller refers to the issue during the year of the sixth volume of the "Flora Australiensis," in the production of which he is associated with Mr. Bentham; towards the composition of the seventh volume he mentions that it will include the Grasses, numbering about 250 species, the Rushes, Sedges, Restiaceæ numbering alone about 70 species, the Naiadææ, Palmacææ, &c. With regard to the number of species, however, these may be considerably modified before publication. In reference to a botanical appendix which Baron Mueller made to the works of Mr. F. A. Campbell, of Geelong, on the New Hebrides and the Loyalty Islands, which appendix was drawn up from collections made by the author during a visit to these islands, he says: "By such means we have obtained the first connected records of the insular vegetation of those spots of the globe after the lapse of more than a century since their discovery. Such opportunities for research should also be seized on by other travellers, and especially by educated settlers residing on these islands, as thereby will be gained not merely an advancement for phytographic science, but also a closer acquaintance with the natural productions of any of the Pacific insular lands, to the advantage also of Australian industries and commerce." With regard to the Paleontology of Victoria, Baron Mueller describes the vegetation of the Pliocene period as remarkable for its densely umbrageous trees of almost tropical types, which, as very recently ascertained, spread over very extensive areas, where in the present nothing of the past physiognomic grandeur of the vegetation is left. The elucidation of new economic plants and the tests as to their value in the world of commerce has long been one of Baron Mueller's special points. His pen has produced many pamphlets on these and kindred subjects, and from his laboratory have issued many actual results of his researches in this direction. The large collection of chemical products from the various species of Eucalyptus, Melaleuca, Acacia, &c., together with other vegetable products of Victoria, will be remembered by many as forming one of the principal features of the Australian Court of the London International Exhibition of 1873. This collection, which included oils, tars, acetic acids, and alcohol from species of Eucalyptus, Melaleuca, Casuarina, &c., as well as fibres, papers, and starches, were, at the close of the Exhibition, presented to the Kew Museum, where they are now exhibited. In regard to what Baron Mueller terms "field service," he says he was engaged for seven days in December 1873 in investigating the plants in the forest regions of the Upper Yarra and the southern branches of the Goulburn River. Measurements were also taken at this time of the heights of some lofty trees of *Eucalyptus amygdalina*, the highest of which, gave 400 ft. To some trees which appeared to be higher access could not be obtained in the short time allowed and the means at command, as the dense jungle would have to be cleared for a base line. A magnificent species of *Festuca (F. divisa)*, discovered in West Gippsland by Baron Mueller in 1860, "was now," he says, "ascertained to have a wide range through the forests

towards the Yarra and Goulburn sources, where among grasses it forms a most stately object, the height of 12 ft. being not unusual, while occasionally this superb grass, in the fern-tree gullies or rivulets, attains, in rich soil, to 17 ft. The result of this journey," Baron Mueller says, "was the discovery of many plants new to Victoria and a few new to science. So far as the country itself is concerned, the Alps are easily accessible for horses from the eastern side, as the slopes are more gradual. The summits can be traversed for many miles with little or no impediment: being at an elevation of from 6,000 to 7,000 ft., they are above the region of trees and shrubs, and are consequently open in all directions."

WE have received the indexes to vol. vii. of "Patents and Patentes," 1872, for the colony of Victoria. The volume contains three separate indexes: "Subject Matter," "Alphabetical Index of Names," "Chronological and Descriptive," and seven-teen sheets of illustrations. The work gives in a compact form a good idea of the activity of inventors in the colony.

THE additions to the Zoological Society's Gardens during the past week include a Black-handed Spider Monkey (*Atles melanochir*) from Central America, presented by Mr. H. Campbell; a Macaque Monkey (*Macacus cynomolgus*) from India, presented by Mr. C. Lucas; a Ring-necked Parrakeet (*Palaeornis torquata*), from India, presented by Miss Attwood; a Yellow-bellied Parrakeet (*Platycecus flaviventris*) from Tasmania; and a Little Grebe (*Podiceps minor*), British, purchased.

#### SCIENTIFIC SERIALS

THE *Quarterly Journal of Microscopical Science* for this month contains several articles and notices of interest, the most important of which are: "Observations on the Anatomy of *Tenia medicamentata*," by Mr. F. H. Welch, in which the author describes the detailed structure of that species, which, as he remarks, is considerably more common than the better known *T. solium*. Two plates accompany the description; very instructive sections through the segments in different directions occupying one of them.—Mr. C. H. Golding Bird describes the method to be employed in imbedding in elder-pith for cutting sections, a method more simple and frequently as advantageous as imbedding in wax, the moistened pith adapting itself to the inequalities and supporting the substance to be cut, in a most convenient manner, without the necessity for a tripod, spirit-lamp, &c., required when wax is used.—Mr. W. Archer has a paper "On Apothecia occurring in some Scytonematous and Sirospheonaceous Algae, in addition to those previously known," in which the transfer by Bornet of *Ephelbe pubescens* to the lichens suggested observations as to whether other species, *Stigonema* and allied genera, would not require similar relegation on account of the discovery of apothecia and spermogonia in them. The question as to the nature of these Gonidia-forming Algae types is discussed.—Mr. Ray Lankester makes "Observations on the Development of the Cephalopoda," in which he continues his elaborate investigations on the development of the Mollusca. The points on which most stress is laid in the present paper are the formation of the blastoderm and the nature of the "autoplasts;" the development of the pen-sac, and of the alimentary canal, and especially of the eye, whose radical similarity in the di- and tetra-branchiate Cephalopoda is proved, at the same time that its great difference from the vertebrate organ is rendered equally apparent.—Mr. H. C. Sorby has a paper "On the Chromatological Relations of *Spongilla fucivittis*," which is shown to contain much the same colouring matter, soluble in carbon-disulphide, as the highest plants, though in different proportions.—The last paper, reprinted from this journal, is Prof. Huxley's "Classification of the Animal Kingdom," read before the Linnean Society in December last.—A review is given of Stricker's "Manual of Histology," as well as an excellent short life, by Dr. Payne, of Dr. Lankester, one of the founders of the journal.

*Astronomische Nachrichten*, No. 2,016.—In this number is a list of some thirty stars, of types iii. and iv., discovered by D'Arrest. Notes on colour and bands in the spectrum of each

are added.—Oppolzer gives the elements of Winnecke's comet (Comet III. 1819), and an ephemeris for every day, from Jan. 1 to March 1, 1875. The eclipse of the sun of October last was observed by H. Bruns and others at Dorpat; four telescopes were used, of 162, 97, 53, and 77 millimetres aperture respectively. It appears that the first contact was observed to take place earlier with the larger instruments than with the smaller; there is a difference of 44 seconds in time in the case of the 162 and 53 millimetre glasses. H. Bruns also contributes some remarks on the finding of the altitude of falling stars.—Dr. J. Holetschek gives elements and an ephemeris for the planet Peitho (118) for the month of Dec.; and Ormond Stone adds a remark on certain equations in the determination of a comet's distance from the earth.—No. 2,017.—Dr. O. Lohse writes to the editor an account of the method of photographing the sun. He apparently uses collodion, containing chloride of silver, or paper, instead of the ordinary sensitive plate. He remarks that the process has the advantage of requiring no chemical preparation for each photograph, and he says the spots are sharply defined.—Prof. Bredichin sends his positions and observations of 22 of the minor planets, the comets of Winnecke, Borrelly, and Coggia; and Fearnley gives a list of 58 stars with their ascertained positions for comparison with Coggia's comet.—Leopold Schulhof gives elements and an ephemeris for the month of Dec. of Planet (139).—Victor Füss gives the times of contact of four observers of the solar eclipse of October last.

THE *Bulletin de la Société d'Acclimatation de Paris* for September opens with a curious instance, related by M. Duwamet, of a cross between the red and common grey partridge; the practical use of which, however, is not apparent, though it is a curious example of a cross between two species of birds hitherto regarded as irreconcilable.—M. La Perre de Roo contributes an article on Military Pigeons, which details the uses to which pigeons may be put for military purposes. Russia, Italy, Austria, and Germany have already created establishments for the breeding and training of pigeons with this object.—M. J. Bech pleads the cause of the small birds in France, most of which, as soon as the legal shooting season commences, are killed in large numbers by sportsmen who cannot find better game. He recommends the absolute prohibition of the slaughter of insectivorous birds.—The acclimatisation of sponges is the latest idea of one of the members of the society, who suggests that the celebrated Syrian sponges might be cultivated in the South of France.—The Notes from America include observations on the Mexican Agave, the introduction of mahogany into India, and the teaproductions of that country.

*Der Zoologische Garten*.—In the November number Dr. von Olfers discusses the food of the Stork (*Ciconia alba*), and its consequent value to the farmer. He finds the principal items of its bill of fare to consist of frogs, moles, grasshoppers, and the larger carabine beetles.—Dr. Dörner reviews the twelve species of Deer now represented in the Hamburg Zoological Gardens; a Stag (*Cervus elaphus*), aged only two years, has already antlers with twelve points.—H. Thienemann remarks on the habits of the Little Bustard (*Otis tetrix*), which has recently established itself as a breeding species in Thuringia, as has also the Fieldfare (*Turdus pilaris*).—Among the remaining articles are notes on *Plotus leucallantii*, by H. Marmo; and on *Tropidonotus tessellatus*, by H. Geisenheyer.

## SOCIETIES AND ACADEMIES

### LONDON

Geological Society, Dec. 16.—Mr. John Evans, F.R.S., president, in the chair.—The following communications were read:—(1) Descriptions of the Graptolites of the Arenig and Llandello Rocks of St. David's, by Messrs. John Hopkinson and Charles Lapworth. Commencing with a brief historical account of the discovery of graptolites in the neighbourhood of St. David's, from their first discovery in the Llandello series in 1841 by Sir Henry De la Beche and Prof. Ramsay, the authors proceeded to explain their views on the classification of the graptolites (*Graptolithina*, Bronn), which they place under the order *Hydrozoa*, dividing them into two groups: *Rhabdophora* (Allman), comprising the true sciculate or virgulate graptolites, which they consider to have been free organisms; and *Cladophora* (Hopkinson), comprising the dendroid graptolites and their allies, which were almost certainly fixed, and are most nearly allied to the recent

*Thecaphora*. The distribution of the genera and species in the Arenig and Llandello rocks of St. David's was then treated of, and the different assemblages of species in each of their subdivisions were compared with those of other areas. The Arenig rocks are seen to contain a number of species which ally them more closely to the Quebec group of Canada than to any other series of rocks, all their sub-divisions containing Quebec species, while the Skiddaw slates, which before the discovery of graptolites in the Lower Arenig rocks of Ramsey Island in 1872 were considered to be our oldest graptolite-bearing rocks, can only be correlated with the Middle and Upper Arenigs of St. David's. The graptolites of the Arenig rocks of Shropshire and of more distant localities were also compared with those of St. David's. In the Llandello series of this district the *Cladophora* have now for the first time been found, a few species, with several species of *Rhabdophora*, occurring at Aberdey Bay in the Lower Llandello, which alone has been carefully worked, there being much more to be done in the Middle and Upper Llandello, from which very few species of graptolites have as yet been obtained. Some of the recently introduced terms, and altered or more definite terminology, employed in the descriptions of the species were then explained; and the paper concluded with descriptions of all the species of graptolites collected in the Arenig and Llandello rocks of St. David's within the last few years of which sufficiently perfect specimens have been obtained, doubtful species being referred to in an appendix. Forty-two species were described, belonging to the following genera:—*Dilymnograptus*, *Tetragraptus*, *Clemagraptus* (gen. nov.), *Dicellograptus*, *Climacograptus*, *Diplograptus*, *Phyllograptus*, *Glossograptus*, and *Trigonograptus* (*Rhabdophora*); *Ptilograptus*, *Dendograptus*, *Callograptus*, and *Dictyograptus* (*Cladophora*). (2) On the age and correlations of the plant-bearing series of India, and the former existence of an Indo-oceanic continent, by Mr. H. F. Blanford. In this paper the author showed that the plant-bearing series of India ranges from early Permian to the latest Jurassic times, indicating that, with few and local exceptions, land and freshwater conditions had prevailed uninteruptedly over its area during this long lapse of time, and perhaps even from an earlier period. In the early Permian there is evidence in the shape of boulder-beds and breccias underlying the lowest beds of the Talchir group of a prevalence of cold climate down to low latitudes in India, and, as the observations of geologists in South Africa and Australia would seem to show, in both hemispheres simultaneously. With the decrease of cold the author believed the flora and reptilian fauna of Permian times were diffused to Africa, India, and perhaps Australia; or the flora may have existed somewhat earlier in Australia, and have been diffused thence. The evidence, he thought, showed that during the Permian epoch, India, South Africa, and Australia were connected by an Indo-oceanic continent, and that the first two remained so connected, with at the utmost some short intervals, up to the end of the Miocene period. During the latter part of the time this continent was also connected with Mayalana. The position of the connecting land was said to be indicated by the range of coral reefs and banks that now exists between the Arabian Sea and West Africa. Up to the end of the Nummulitic epoch, except perhaps for short periods, no direct connection existed between India and Western Asia.

Zoological Society, Jan. 5.—Dr. E. Hamilton, vice-president, in the chair.—A letter was read from Dr. George Bennett, of Sydney, giving an account of an Indian beetle (*Chrysochroa ocellata*), which had been captured alive in the Bay of Bengal, 273 miles from the nearest land, by Capt. Payne, of the barque *William Manson*.—A letter was read from Mr. Anderson, of Fetteyghur, East Indies, giving an account of the eggs and young of the Gaviol (*Gaviolus gangeticus*).—The Secretary read a letter addressed to him by the Marquis of Normanby, Governor of Queensland, announcing that he had forwarded by the ship *Ramsay*, under the care of Capt. Carter, a fine specimen of the Australian Cassowary (*Casuarus australis*), as a present for the Society's collection.—A communication was read from Mr. A. G. Butler, giving descriptions of thirty-three new species of *Splingidae* in the collection of the British Museum.—A communication was read from Mr. Andrew Anderson, of Fetteyghur, giving corrections of and additions to a previous paper by him on the Raptorial Birds of North-western India (E.Z.S., 1872, page 619).—A communication was read from Mr. E. L. Layard, H.B.M. Consul for Fiji and Tonga, containing ornithological notes made in the Fiji's, together with descriptions of some supposed new species of birds.

Royal Microscopical Society, Jan. 6.—Chas. Brooke, F.R.S., president, in the chair.—Dr. Ord read a paper on the natural history of the common urates, in which he described the results of a number of experiments with urates of soda and ammonia, carried on with a view to ascertain what was the meaning of the different forms in which they appeared in the animal system. The various forms assumed by these salts in colloid media, and under the action of acids or chlorides, were described at some length, and the subject was further illustrated by drawings and preparations exhibited in the room.—A paper by Dr. Pigott, on the invisibility of minute refractory bodies in consequence of excessive aperture, was read by the Secretary.—Some beautiful sections of a foraminifer (*Avalonia*), both transverse and longitudinal, mounted by Möller, were exhibited by the Assistant Secretary.

Royal Geographical Society, Jan. 12.—Sir Rutherford Alcock, vice-president, in the chair.—A letter was read from Lieutenant-Colonel C. C. Long, a staff officer in the Egyptian service, giving the Society an account of his recent journey to King Mtesa, on the shores of Lake Victoria Nyanza. According to Col. Long's account, he left Gondokoro on the 24th of April last, charged by Col. Gordon with a friendly mission to the powerful King of Uganda (King Mtesa), and accompanied by two Egyptian soldiers and two servants. The journey occupied fifty-eight days, at the end of which the party was rewarded by the sight of the richly-cultivated central district of Uganda, appearing like a great forest of bananas. King Mtesa received the envoy with great friendliness, and ordered thirty of his subjects to be decapitated in honour of the visit. Permission was given Col. Long to descend "Murchison Creek" and view Lake Victoria. The journey from Mtesa's residence occupied three hours, and the party embarked on canoes made of the bark of trees, sewn together. Col. Long sounded the waters of the lake, and found a depth of from 25 to 35 feet. In clear weather the opposite shore was visible, appearing "to an unnautical eye" from twelve to fifteen miles distant; he did not think he could possibly be greatly deceived in this estimate. After much negotiation and opposition, he obtained permission to return to Egyptian territory by water, and on the way, in lat 1°30', discovered a second lake, or large basin, at least twenty to twenty-five miles wide. He found the Upper Nile from Ripon Falls to Karuma Falls a fine navigable stream large enough for the *Great Eastern*. He finally reported from Gondokoro (October 20) that Col. Gordon would soon have a steamer on Albert Nyanza, and intended also to move one to the Upper Nile above Karuma.—A paper was then read "On a Journey along the East Coast of Africa, from Dar-es-Salam to Kilwa, in December 1873, by Capt. F. Elton," the chief point of which was that the Rufiji River was found above the head of the delta to have an average depth of only four to five feet.—Major Erskine (late Colonial Secretary of Natal) then read a paper on his son's (Mr. St. Vincent Erskine) recent mission to the powerful Kafir chief Umsila, whose territory stretches along the richly-wooded and fertile interior country between the Limpopo and the Zambezi. Umsila's head-quarters are near the ruins of Zimbabwe, where the German traveller, Carl Mauch, discovered sculptured stones, supposed by some to be of great antiquity. Major Erskine stated that his son had just returned from a second visit to Umsila and Sofala.

PARIS

Academy of Sciences, Jan. 4.—M. Frémy in the chair.—The following papers were read:—Note on magnetism *à propos* of a recent communication by M. Lallemand, by M. Th. du Moncel.—Memoir on the resistance of protozooids to the different dressing materials employed in surgery, by M. Demarquay.—On the decomposition and preservation of wood, by M. Max. Paulel.—On the germination of the "Chevallier" barley, by M. A. Leclerc.—Communications relating to Phylloxera were received from MM. L. Roesler, G. Beaume, P. Jolly, and others.—The French Minister in China forwarded a despatch from M. Fleurbaey, dated from Shanghai, Dec. 26, and announcing the successful result of the Transit of Venus observations.—The following letters from various observing stations were also read:—From MM. Ch. André and A. Angot, at Noumea, dated Oct. 8; from M. J. Janssen, at Nagasaki, dated Nov. 4; from M. Héraud, at Saigon, dated Nov. 22; and from M. P. Tacchini, at Muddapur (Bengal), dated Dec. 10. This last communication makes known that the spectroscopic observations of the Transit were satisfactory, and tend to show that the diameter

of the sun is smaller when seen in the spectroscopie than when observed by the other method.—On the calculus of geodesic co-ordinates, by M. Ch. Trepiéd.—On the expression of work relative to an elementary transformation, by M. J. Moutier.—Analogies between the disengagement of gases from their super-saturated solutions and the decomposition of certain explosive bodies, by M. D. Gernez.—On the atomic structure of the molecules of benzene and terbene, by M. G. Hinrichs.—On the titanic ethers with M. E. Demarcay. One molecule of titanic chloride is mixed in small portions with four molecules of absolute alcohol, and the mixture heated to 80°-100° *in vacuo*, when hydrochloric acid and the excess of alcohol are removed and a crystalline mass obtained which has the composition of the chlorhydrate of monochlorhydrine,  $Ti(OCl_2H_2)Cl.HCl$ . This body forms white crystals, melting at 105°-110°, and decomposable by water. Sodium ethylate dissolved in excess of alcohol is added to an alcoholic solution of the chlorhydrate, when sodium chloride is precipitated, and the alcoholic solution yields on evaporation white crystalline needles of the ether  $Ti(OCl_2H_2)_2$ .—On the pyruvic ureides: Condensed ureides; by M. E. Grimaux. The author now considers dipyruvic triureide,  $C_7H_8N_2O_5$ ; tetrapyruvic triureide,  $C_{12}H_{14}N_4O_8$ ; and dipyruvic tetraureide,  $C_{12}H_{14}N_4O_7$ .—On the shooting stars of November 13 and December 10, 1874, by M. Gruy.—Aerial corpuscles and saline matters contained in snow, by M. G. Tissandier.—Researches on the gastric juice, by M. Rabateau. The author's experiments confirm the results obtained by Braconnot, Prout, Lassaigne, and Schmidt—that the acidity of the juice is due to hydrochloric and not to lactic acid.—On the nature of syphilitic affections, and on mercurial treatment, by M. J. Hermann.

BOOKS AND PAMPHLETS RECEIVED

BRITISH.—The Microscopie and its Revelations: Wm. B. Carpenter, M.B., LL.D. (J. and A. Churchill).—The Apparent Absence of Air and Water from the Moon: Francis Raper (Philosophical Society of Glasgow).—Some Reasons for doubting the Alleged Transit of Venus (Hodder and Stoughton).—Report of the Royal Committee, for year ending Oct. 31, 1874.—Remarks on the Great Logarithmic and Trigonometrical Tables computed in the Bureau du Cadastre under the direction of M. Prony: Edward Sang.—A Short History of the English People: Rev. J. K. Green, M.A. (Macmillan and Co.).—The Amazon and Madeira Rivers: Zeal Kuller (Chapman and Hall).—Chemical and Geological Essays: T. Sterry Hunt, LL.D. (Trübner).—The Transit of Venus; its Meaning and Use: T. H. Rudd, F.R.A.S. (Longmans).—Two Years in Peru, with Exploration of its Antiquities: Thos. J. Hutchinson, F.R.G.S., F.R.S.L., M.A.I., &c. (Sampson Low, Marston, Low, and Sealoe).

AMERICAN.—Report of the Commissioner of Fish and Fisheries of the United States, 1872-73 (Washington).—Memoirs of Society of Natural History: The species of Lepidopterous Genus Pamphila: Samuel H. Scudder (Published by the Society).—Report of the Medical Commission upon the Sanitary Qualities of the Sudbury, Mystic, Shawmut, and Charles River Waters (Boston, Rockwell and Churchill).—Results derived from an Examination of the United States Weather Maps for 1872-73: Elias Loomis (From American Journal of Science and Arts).—Jeffries Wyman Memorial Meeting of the Boston Society of Natural History.

COLONIAL.—Appendix to New Vegetable Fossils of Victoria: Baron Ferd. von Mueller, C.M.G., M.D., Ph.D., F.R.S.—Journal of the Asiatic Society of Bengal (G. H. Kouse, Calcutta).—Proceedings and Transactions of the Nova Scotian Institute of Natural Science (Wm. Gospie, Halifax, N.S.).—Durability of New Zealand Timber (Report read by Mr. Thomas Kirk).

CONTENTS

	PAGE
THE APPROACHING ECLIPSE OF THE SUN	201
COUNT RUMFORD'S COMPLETE WORKS. By W. MATTHEW WILLIAMS, F.R.S.	202
THE SILK-WORM COCOON	203
OUR BOOK SHELF:— Thomson's "Straits of Malacca" &c.	207
LETTERS TO THE EDITOR:— The Hoffmeyer's Weather Charts.—ROBERT H. SCOTT, F.R.S.	208
A New Bird of Paradise from the Island of Waigeou, near New Guinea.—DR. A. L. MEYER	208
Chappell's "History of Music."—WM. CHAPPELL	208
Origin of Bright Colouring in Animals	208
King Blackbird.—HERVEY GREGG	209
THE NEW WESTERN CHINA EXPEDITION	209
THE ACCLIMATISATION OF SALMON IN OTAGO	209
ON THE EXISTENCE OF THE FALLOW DEER IN ENGLAND DURING PLEISTOCENE TIMES. By VICTOR BROOKS ( <i>With Illustrations</i> )	210
HELMHOLTZ ON THE USE AND ABUSE OF THE DEDUCTIVE METHOD IN PHYSICAL SCIENCE	211
NEW ZEALAND PLANTS SUITABLE FOR PAPER-MAKING. By JOHN R. JACKSON	212
A FRENCH OFFICIAL ACCOUNT OF THE ORIGIN OF THE ROYAL SOCIETY	213
THE TRANSIT OF VENUS	214
ON THE AGE OF AMERICAN STONE IMPLEMENTS, OR "INDIAN RELICS." By CHAS. C. ABBOTT	215
NOTES	215
SCIENTIFIC SERIALS	215
SOCIETIES AND ACADEMIES	219
BOOKS AND PAMPHLETS RECEIVED	220

THURSDAY, JANUARY 21, 1875

## DR. LLOYD'S "TREATISE ON MAGNETISM"

*A Treatise on Magnetism, General and Terrestrial.* By Humphrey Lloyd, D.D., D.C.L., Provost of Trinity College, Dublin. (London : Longmans and Co., 1874.)

AN observational science like meteorology or terrestrial magnetism is placed in some respects at a disadvantage when compared with the more experimental branches of physical inquiry. It is often difficult to obtain a good and readable account of that which has been done. The reason of this is, that those who are personally engrossed with the science have to deal with such large masses of figures and precise measurements that they are frequently unable to spare the time necessary to give a good historical account of their favourite research. Those again who are the historians of science find it a very formidable task to bring themselves *en rapport* with all that has been done in such a subject as terrestrial magnetism—in fine, there is not sufficient inducement to undertake the task. No doubt, when such a science is more advanced and has attained a position like that of astronomy, it will find plenty of historians; but in its infancy, and when a good *résumé* of the progress already made is of peculiar value, it has comparatively few friends. Now these are precisely the circumstances when a Government or a University is able to interfere with very great effect, and with respect to terrestrial magnetism this opportunity has been admirably used by Trinity College, Dublin. The Rev. Dr. Lloyd tells us in his preface that the Dublin Magnetic Observatory was founded and placed under his superintendence by the governing body of Trinity College in 1838. This college has been peculiarly fortunate in having chosen as an observer the eminent physicist who is now its provost, and who, besides reaping much fame as a practical magnetician, has at length found leisure to present us with the much-required treatise on terrestrial magnetism.

The first part of this work refers to the general phenomena of magnetism, and contains one of the clearest accounts of the elementary laws of this subject which we have ever read. Some of the experiments recorded we do not remember to have seen anywhere else.

One of the most interesting preliminary chapters is that on the effects of temperature. It is well known that heat has a very peculiar effect upon all magnets. The following paragraph from Dr. Lloyd's work will explain the particulars of this action:—

"Heat is also found to weaken the coercive force of iron, and therefore to facilitate its magnetisation and demagnetisation. When a bar of iron is heated and exposed to the inductive action of a strong magnet, the magnetism developed is augmented. This effect increases up to a *dull red* heat, at which it is a *maximum*. At a *bright red* heat the capability of induction ceases altogether. *Cast-iron* and *steel* present the same results. The maximum force imparted to soft iron has been found by M. Ed. Becquerel to be 104, that imparted at the ordinary temperature of the air being unity; and it is a remarkable circumstance that the maximum force induced in *cast-iron* and in *steel* is precisely the same as that of *soft iron*, although at ordinary temperatures their induced magnetisms are very different. It appears from these facts that the coercive force of these bodies vanishes altogether at a *dull red heat*" (p. 23).

Although it may be convenient to speak of the magnetic fluid, yet we think there can be little doubt that in a magnet we have directed molecular motion of some kind. This, we believe, is the hypothesis held by Sir W. Thomson and other physicists. The author of this notice has ventured to bring forward certain views as to the action of heat in destroying all directed motion. We know, for instance, that the conduction of electricity and of heat, two forms of directed molecular motion, is more resisted at high than at low temperatures. The analogy urged to explain this was that of a carriage or train in motion, on a road lined with passengers who were constantly entering at the one side while they were passing out of it at the other.

A stream of passengers of this nature would have the effect of bringing the directed motion of the train ultimately to rest. Now, heat may affect directed molecular motions in the same way, carrying into the train matter which does not partake of the motion of the train, and carrying out of the train matter which does partake of this motion, and so weakening the velocity of the train. Even visible directed motion may be influenced in this way, and it does not seem improbable that the etherial medium may act after this fashion in stopping the differential motions of the universe.

Now the question arises, is it likely that we have any action of this nature traceable in the effects of heat upon magnetism? Let us again quote from Dr. Lloyd as to certain peculiarities of the action of heat:—

"When the heat applied to a steel magnet is moderate—when, *e.g.*, it does not exceed that of boiling water—part of the magnetism which had disappeared on the increase of temperature reappears when the original temperature is restored. It follows from this that heat produces two effects, which (in the present state of our knowledge) must be considered as distinct.

"Like mechanical action, it permanently *destroys* a portion of the existing magnetism by enabling the two magnetisms which had been separated in each molecule to recombine. And, on the other hand, it *renders latent*, or neutralises, another portion of the same magnetism, which portion reappears again when the temperature is reduced to its original state.

"This two-fold operation of heat, although fully recognised as a fact, has not been sufficiently considered in reference to the cause. There seems reason to believe that the two effects, so dissimilar in their conditions, are, in fact, referable to distinct causes; and that while the permanent loss of magnetism is a *dynamical effect* due to the *molecular movement* in which heat is known to consist, the recoverable portion is probably to be ascribed to the *dilatation* of the body and to the diminution of the reciprocal action of the magnetic elements consequent upon their increased distance."

We quite agree with Dr. Lloyd in his remarks on these two effects of heat, and would venture to supplement them with a suggestion as to the possibility of regarding the *dynamical effect* of heat as due to the introduction of new matter—new passengers, as it were—into the directed train of magnetic motion. If this view be tenable, we may perhaps imagine that a permanent loss of magnetism will be occasioned by every change of temperature of the magnet, whether this be from a lower temperature to a higher or from a higher temperature to a lower; in fact, as far as we can see, all the experiments hitherto made are just as compatible with this supposition as with

that which attributes a permanent loss of magnetism only to an increase of temperature.

We now come to the most valuable part of the work, or those chapters which treat of terrestrial magnetism. Dr. Lloyd tells us in his preface that the course he has pursued has been "to present the results obtained at a single station, *i.e.* Dublin, at which all the general features of the phenomena belonging to the middle northern latitudes were fully developed, and to supplement the information by the results of observation at places widely removed from the former in geographical position, as well as in their relation to the sun's daily and yearly courses."

Dr. Lloyd adds that "he has not entered upon the interesting speculation connected with the physical causes of the phenomena, further than to reprint a paper, published by himself many years ago, in which the agency of the sun and moon are shown not to be due to their direct operation as magnetic bodies." And he concludes his preface by remarking that "the electrical earth-currents must have their effect upon the magnetical variations recorded in our observatories, whether they be the sole, or only a co-operating cause."

Are we justified in our inference, from the concluding observation, that Dr. Lloyd has to some extent modified his views with regard to the importance of these earth-currents? for, if we are not mistaken, he was at one time inclined to attribute the daily variations of terrestrial magnetism to their operation.

Speculations regarding the causes of the phenomena of terrestrial magnetism may be divided into two classes: first, those which attempt to account for the magnetisation of the earth; and secondly, those which only pretend to account for the changes taking place in this magnetisation. It is from the latter point of view that we would now venture to make a few remarks.

Let us assume, to begin with, that nothing is definitely known regarding the causes of these changes. Let us next endeavour to enumerate and discuss the various agencies we know of which may be conceived to take a part in producing these phenomena, in the hope that by a preliminary trial of its kind we may, perhaps, light upon the true cause, even although the evidence at our disposal be insufficient to give certainty to our suspicions.

In the first place, we may take it for granted that neither the sun nor the moon can cause the changes in terrestrial magnetism, which they are known to produce, by virtue of their direct magnetic influence.

This point has been sufficiently discussed both by Dr. Lloyd and by Mr. Chas. Chambers, and the conclusion to which both of these magneticians have arrived is, that the magnetic effects caused by the sun and moon are not due to their direct operation as magnetic bodies.

Let us take the sun and confine ourselves in the meantime to the daily variations which he causes. Now, first of all, it is clear that these are not due to any kind of tidal action of the sun, or to the indirect consequences of such an action, inasmuch as there is only one maximum and one minimum in the day.

The only other known way in which the sun can affect the earth is through his heat; and starting with the assumption that the earth is a magnet, no matter how or why, let us next enumerate the various ways in which the heat of the sun may possibly affect the earth.

In the *first* place, it might influence the magnetic properties of that medium (the air) which surrounds the earth and any suspended magnet.

Or, *secondly*, it might produce a temperature effect upon the earth itself considered as a magnet.

Or, *thirdly*, it might be conceived to generate thermo-electric currents in the earth.

Or, *fourthly*, it might cause the motion of conducting bodies across the earth's lines of magnetic force.

The first of these is the hypothesis of Faraday; and while the change produced by heat in the magnetic qualities of the atmosphere cannot be without its influence, yet it is, we believe, the universal opinion of magneticians that this change cannot account, either in magnitude or law, for the somewhat considerable daily variation. The diurnal change produced by the sun's heat in the magnetic condition of the crust of the earth must be still more insignificant, and may be at once dismissed.

Our attention is thus concentrated, on the third and fourth of the above possible causes, one of which we may perhaps expect to account for the daily variation, unless this be due to some cause of the nature of which we are entirely ignorant.

It is now well known that what are called earth-currents are of very frequent, if not continuous occurrence, and we are indebted to the present Astronomer Royal for an experiment made with the view of ascertaining the nature of the relation between these currents and the changes of terrestrial magnetism. He set up certain wires on the Croydon and Dartford lines, which gave him, by means of a self-recording arrangement, a continuous record of the strength and duration of these earth-currents, and the following is the conclusion which he has derived from the discussion of these observations:—

"Neither in magnitude nor in law are these inequalities consequent on the galvanic currents competent to explain the ordinary diurnal inequalities of magnetism."

In fact, there is some reason to regard these currents rather as the *effects* than as the *causes* of magnetic changes, that is to say, to view them as secondary currents; and the author of this notice has shown in a paper, published in the Transactions of the Royal Society of Edinburgh, that these earth-currents are strongest at those periods of the day when the change in terrestrial magnetism is most rapid—a result which would follow if the earth-currents were secondary currents due to magnetic changes. Our attention is thus drawn to the fourth hypothesis as the only remaining conceivable cause of magnetic changes, unless these are caused by something of which we are entirely ignorant.

It is known that Faraday tried to detect induction currents in the Thames, supposing that these might be caused by the carriage of a conducting liquid across the earth's lines of magnetic force, but found no positive result. Sir W. Thomson afterwards made a proposal to test the idea by tides in the English Channel, but we do not think this has ever been carried out. He also discussed to some extent the part which may be played in the phenomena of terrestrial magnetism by moving conductors.

But to return to the fourth hypothesis. In the first place, let us ask ourselves the question, Under what circumstances can the convection currents generated by the

sun's heat become conductors? Now, this can only take place in the upper and rarer regions of the atmosphere, since dense air is manifestly a non-conductor. We have therefore in the upper regions of the air a conductor—rare air—conveyed across the earth's lines of force by the convection due to the sun's heat, probably with a very considerable velocity. Now, is it not possible that these moving conductors may have currents generated in them which will act upon the magnet both directly and through the earth? As far as we are aware no attempt has yet been made to treat the question mathematically; indeed, we are hardly prepared for that at present, since we know very little about the convection currents in the upper regions of the earth's atmosphere.

We may perhaps, however, deduce the laws of the upper convection currents from what we know of the lower currents. Now, there are several points of similarity between the convection currents as we know them and the daily magnetic variations. The *first* in order is that noticed by Mr. Baxendell, who observed a very strong likeness between the daily behaviour of the wind and that of the magnetic declination.

The *next* is a resemblance between what we know takes place near the equator as regards the magnetic declination and what we imagine must take place as regards the upper convection currents. Sir E. Sabine has shown that near the equator the diurnal magnetic change is of an opposite character during the two halves of the year reckoning from the equinoxes, so that it is only at or near the equinoxes that the diurnal inequality might be expected to vanish as it passes from the one phase to the other. Now, we should quite expect something of this kind if the diurnal changes were due to convection currents; and just as the change which we might expect in the convection currents of these regions on account of the motion of the sun in declination would probably not be gradual, but of a hesitating or oscillatory character, so Mr. J. Allan Broun has found from his magnetic observations at Trevandrum (page 180 of Dr. Lloyd's work) that the magnetic change is not a gradual or regular one. This is a very important remark, and if followed up by a thorough discussion of the various tropical magnetic observations, may be expected to throw much light on the cause of the daily variation.

The third point we would notice is a peculiarity in the behaviour of the daily magnetic variation near the magnetic pole.

"The observations of Sir Leopold M'Clintock in 1838—59, at Port Kennedy," says Dr. Lloyd, "have enabled Sir Edward Sabine to throw further light upon the laws of the diurnal variations. The declination at Port Kennedy is N. 136° W.; while that of Point Barrow is N. 41° E. The north poles of the needles at the two stations, which are at opposite sides of the earth's magnetic pole, thus point in opposite directions. Now, when disturbances are removed, the observations gave the greatest deflections at 8 A.M. and 2 P.M., as in other places. But they showed, further, that the positions were referred in both to the magnetic meridian of the place, and not to the astronomical; the deviations of the magnet at 2 P.M., for example, being in both places to the left of an observer looking towards the magnetic pole at each place, and therefore geographically in opposite directions."

Now, meteorologically, the north magnetic pole is not far from the pole of greatest cold, and we might, perhaps,

expect on opposite sides of the pole to find the upper convection currents going in opposite directions. If this be the case, and if the daily variation be due to those currents, then we might also expect a magnetic behaviour such as was deduced by Sir E. Sabine from the observations of Sir L. M'Clintock.

We think, in fine, that the behaviour of the daily variation at the tropics, at middle latitudes, and near the magnetic pole, is not inconsistent with the hypothesis that such variation is due to convection currents. But if this hypothesis be true, it cannot be limited to the daily variation. We know very well that the currents of the earth's atmosphere often present great irregularities, and that these irregularities are especially prevalent at the equinoxes. Now, we have a precisely similar peculiarity in magnetic changes. These are frequently irregular, and their irregularities are greatest at the equinoxes. In proof of this we extract the following table from Dr. Lloyd's work:—

Annual variation of the mean disturbance at Dublin.

Month.	Mean Disturbance.	Month.	Mean Disturbance.
January	0·48	July	0·57
February	0·57	August	0·56
March	0·58	September	0·67
April	0·57	October	0·66
May	0·53	November	0·59
June	0·48	December	0·45

The next point to which we would allude is a similarity between the secular variation of the meteorology and magnetism of the earth. Mr. Baxendell, we think, was the first to point out that there is a change in the convection currents of the earth, depending on the state of the sun's surface with regard to spots; and Mr. Charles Meldrum has followed with the very interesting and important announcement that we have most frequent cyclones in the Indian Ocean during years of maximum sun-spots; and finally, M. Poey has shown that there is a similar correspondence between sun-spots and the hurricanes of the West Indies. In fine, we have here an intimate connection between solar and terrestrial meteorology. But we have also a connection between sun-spots and magnetic disturbances; and Sir E. Sabine was the first to point out that during the years of greatest sun-spots we have the greatest disturbance of terrestrial magnetism. Now, may not the increase of magnetic disturbance be due to the increase of meteorological disturbance which the sun somehow produces, the upper convection currents influencing the magnet in the manner above stated?

It is probable, however, that some will raise the following objection to this hypothesis. When there is a great magnetic storm or disturbance, this takes place simultaneously and abruptly throughout the whole earth; now, how can this be the result of a meteorological commotion?

We would reply to this objection that magneticians have begun to recognise two sets of disturbances.

When the writer of this notice was at the Kew Observatory, this was forcibly brought before him. There are disturbances of a rounded character, and there are others which are exceedingly abrupt; and we think that Senhor Capello has shown that these rounded disturbances are

certainly not simultaneous between Kew and Lisbon. The abrupt disturbances constituting magnetic storms are, however, probably simultaneous all over the world. It is thus possible to imagine the former or rounded disturbances to be caused by convection currents, but it is quite impossible to regard the latter as so caused. How, then, can these be accounted for consistently with this hypothesis? We reply, that when there is a considerable disturbance in the convection currents of the earth, these currents, as we have explained, conveying electricity, we may then expect such currents to influence and alter the magnetism of the earth. The earth gets out of relation as a magnet to these currents, and rights itself abruptly; and this abrupt change of the earth occurring simultaneously all over it, may form the second kind of magnetic storm.

Corresponding to these two varieties of magnetic disturbances, we have, in all probability, two kinds of auroras.

The upper convection currents of the earth, if they convey electric currents, may probably be self-luminous, and this may account for auroras of a local nature, and perhaps also for the nearly perennial displays of auroras near the magnetic pole.

On the other hand, whenever we have an abrupt magnetic storm we have the production of secondary currents due to the small but abrupt changes taking place in the magnetism of the earth, and these secondary currents will manifest themselves both in the upper strata of the earth's crust, which are conductors, and in the upper strata of the earth's atmosphere, which are also conductors. In the former case they will produce violent earth-currents; in the latter they will produce a magnificent auroral display, cosmical rather than local in its characteristics.

We have already alluded to the Greenwich self-recording instruments for registering earth-currents, and the author of this notice has inspected several of the curves given by the Greenwich instruments during violent magnetic storms. The characteristic of these traces is an abrupt and violent change from positive to negative and from negative to positive. Now, this is a behaviour quite in accordance with the hypothesis that these are secondary currents due to magnetic changes, but quite inconsistent with the hypothesis that they are themselves the causes of such changes.

Altogether, we would venture to conclude, *firstly*, that if the changes of terrestrial magnetism are not due to some such cause as that which we have stated, then they must be due to some cause of which we are entirely ignorant; and, *secondly*, that the laws of the magnetic changes are, in all the points we have examined, consistent with the idea that they are due to the carriage of conductors across the earth's lines of force.

B. STEWART

#### SIMON'S "SPIDERS OF FRANCE"

*Les Arachnides de France.* Par Eugène Simon, Vice-Président de la Société Entomologique de France. Tome premier. (Paris, 1874.)

EXCEPTING two or three, either partial or abortive, attempts at the early part of the present century, by Baron Walckenaër, no effort has, until now, been

made to supply a history of the spiders indigenous to France. This is the more remarkable, inasmuch as though Arachnology has but few votaries in any country, yet England, Sweden, Prussia, and even Italy, have furnished more or less complete works on their respective spider-faunas. Looking again at the geographical position of France, perhaps few other equal areas would give such a promise of rich results to the araneologist; with all the advantages of an insular position, France combines those of the general Continent of Europe; and her climate ranges from the sub-arctic, in her mountain regions, to the semi-tropical on the Mediterranean shores. We may confidently, therefore, expect a vast addition to our knowledge of European spiders from the labours of the industrious author who has stepped into the breach, and whose first volume on the Spiders of France stands at the head of this notice.

As its title implies, the work is intended to embrace more than the one order (Araneidea) of Arachnids; certainly (it is understood) the orders Scorpionidea and Phalangidea; but whether it will extend also to the other orders, is yet undecided. The present volume, pp. 1-269, Pl. i. ii. iii., embraces five families of the order Araneidea (or Araneæ). It is a matter of regret that it had not been practicable to retain a systematic sequence in regard to the details of the order; the reason given for this is that the author has taken first those families of which he was in possession of the amplest materials; another drawback also seems to be, that the Introduction, "comprising general remarks on the class Arachnida and its bibliography," will not appear until later; when it will, however, be specially pagged for addition to the first volume. The volume before us begins with a useful glossary of special terms used in the descriptions; to this follow (pp. 5-15) some general remarks on the characters of the order ARANEÆ, and some criticisms on the more extended works of different authors upon it; concluding with the outlines of the classification adopted in the present work. In regard to classification but little alteration is proposed from that contained in a paper, "Aranéides nouveaux ou peu connus du Midi de l'Europe, 2<sup>e</sup> mémoire," by the author,\* published (according to the title-page of its author's presentation copies) in 1873, in "Mémoires de la Société Royale des Sciences de Liège."

For the principles of M. Simon's primary divisions of the Araneidea we are referred to the second memoir above mentioned; there, after giving his reasons for dissenting from the primary divisions adopted by Dr. Thorell in his work "On European Spiders," the author divides the Araneidea into four sub-orders:—1. THERAPHOSÆ; 2. GNAPHOSÆ; 3. ARANEÆ; 4. OCULATÆ. The sequence of these is reversed in the volume before us; the name of the third is changed to *Araneæ vera*, and of the fourth to *Araneæ oculata*. The addition to the name of the third order was necessitated by the adoption of the term Araneæ

\* This paper does not, however, appear yet to have been "published" in the only true acceptance of the term; that is, offered to the public for sale; and, it is understood, will not be so published until 1875. This is in some respects a matter of importance, inasmuch as the claim of many species and some genera to the names under which they are, or will be, characterised in the present work, rests for their priority upon the date of publication of the above paper in the *Mém. Liège*. Similar remarks apply to the 2<sup>e</sup> *Mémoire* on "Aranéides du Midi de l'Europe," the presentation copies of which were issued in 1870, while the volume containing it was not published until 1873.



(Sundevall) as the name of the whole order, in lieu of Araneidea—Aranides. With regard to this change, it has the opinion and authority of Dr. Thorell in its favour; and something may be said for it on its own merits; but still, similar terminations (such as in the present instance the ordinal termination -eidea, in the class Arachnida), when adopted for the designation of parallel groups in nature, are of considerable use in fixing the necessary framework of classification in the mind. The grouping, however, of the different families in M. Simon's four sub-orders will, we may anticipate, hardly find much favour among araneologists. The "Araneæ veræ" form an exceedingly heterogeneous group, including as it does spiders so widely separated as the Thomisides and Pholcides! The "Gnaphosæ," also, consisting only of the Dysderides and Scytodides, comprise two very distinct groups, with little in common except the number of the eyes, and the mode of adaptation of the palpal organs to the digital joints of the male palpi; characters found also among the "Araneæ veræ," as well as among the "Theraphosæ."

With respect to the distinguishing characters given of the sub-orders "Araneæ veræ" and "Araneæ oculatæ" (*Yeux diurnes* and *Yeux nocturnes*)—the former coloured and convex, the latter vitreous and flattened—some detailed proof of these differences producing the results asserted would seem to be necessary. Differences, indeed, there are between the eyes of various spiders: some are undoubtedly flattened, some misshapen, and, as in the genus *Æcobius*, apparently more or less aborted; some also are of a pearly-white lustre, some dark, and others brilliantly coloured; but that the eyes of spiders may be distinguished as nocturnal or diurnal by the presence or absence of colour, is an idea at least opposed to the views of an eminent insect anatomist, M. F. Müller, who, as long ago as 1826, "Zur Vergleichenden Physiologie des Gesichtsinnes," wrote against M. Marcel de Serres in regard to a similar point among insects. Apart, however, from this point, it would seem scarcely necessary to attempt the very difficult task of dividing into sub-orders a group so homogeneous as the order Araneidea.

The linear arrangement of the families adopted by M. Simon is very natural, and the interpolated names of his Sub-orders appear to be of little assistance as mere divisional marks, while their scientific tenability seems also, as hinted above, very questionable. M. Simon, while attributing confusion of mind to Dr. Thorell (Note 1 to p. 10) in regard to his notions respecting Orders and Families, appears to have himself fallen into some confusion in regard to the difference between Orders and Sub-orders; in the note above quoted these two kinds of groups are spoken of as though of equal significance in classification, and as being similarly characterised. An Order, however (characterised by complications of structure common to all the families of which it is composed), limits a group within a CLASS; while the Sub-order limits a group within the Order; a group distinguished differentially from the Order by some special complications of structure peculiar to itself. Each of M. Simon's four Sub-orders should, consistently with his definition of those groups, be based "Sur un caractère anatomique profond, indépendant de la forme, mais indiquant une

supériorité ou une infériorité dans les limites de la classe." When we turn, however, to the characters given (in the Mémoire before quoted), we find some considerable details given under each of the Sub-orders; but the special anatomical character indicating the superiority or inferiority of each is not apparent. If the difference between *Yeux diurnes* and *nocturnes* be the character intended, no mention is made of it in respect to the Theraphosæ, while the *Araneæ veræ* possess eyes of both kinds, "the two central eyes of the first row are diurnal, the other six nocturnal." And even supposing these characters to be good and constant, it is not easy to see what superiority or inferiority is indicated by them. All recent investigation tends to lessen the value of characters taken merely from the eyes of spiders, for higher divisional purposes. Supposing they are so, all we could say is, that they are modified and adapted to the habits of the different spiders, and are thus, at most, valuable for *specific* determinations.

Passing on to the body of the work, we find good terse descriptions of 131 species of spiders distributed among the six families—Epeiridæ, Uloboridæ, Dictynidæ, Enyoidæ, and Pholcidæ; the genera comprised in these being twenty-three in number. The genus *Epëira* absorbs thirty-nine out of the twenty-four species contained in the whole family EPEIRIDÆ, the remainder being distributed as follows:—*Peltosoma*, 2; *Argiope*, 2; *Cyrtophora*, 1; *Cyclosa*, 5; *Larinia*, 2; *Singa*, 8; *Cercidia*, 1; *Zilla*, 6; *Meta*, 3; *Tetragnathia*, 5. In the family ULOBORIDÆ are four species distributed between two genera: *Uloborus*, 3; *Hyptiotes*, 1. The family DICTYNIDÆ contains thirty-six species, distributed among four genera: *Dictyna*, 14; *Lethia*, 5; *Titanæca*, 7; *Amaurobius*, 10. The family ENYOIDÆ comprises three genera and eleven species: *Ceto* (gen. nov.), 1; *Selamia*, 1; *Enyo*, 9; while the last of the families contained in the present volume, PHOLCIDÆ, has three genera and five species: *Holocnemus*, 1; *Pholcus*, 2; *Spermophora*, 2.

The above families are characterised at considerable length, and the diagnoses of genera are terse and good. An analytical table, with cross-references of the chief characters of all the families intended to be included in the work, is given at page 14; similar tables are also given of the genera and species; of some of the genera, separate tables of the males and females are given.

Of the twenty-three genera contained in this first volume, two—*Larinia* and *Ceto*, in the family Enyoidæ—are characterised as new. The species described as new are sixteen in number: six in the family Epeiridæ, genera *Larinia*, *Epëira*, and *Tetragnathia*; eight of Dictynidæ, in the genera *Dictyna*, *Lethia*, *Titanæca*, and *Amaurobius*; and two of Enyoidæ, in the genus *Enyo*. The semi-tropical character of the present portion of the spiders of France may be noted in the genera *Holocnemus*, *Argiope*, *Cyrtophora*, *Ceto*, *Selamia*, *Enyo*, *Peltosoma*, and *Spermophora*.

The plates illustrating this volume—three in number—are engraved on copper, and reflect great credit on both the artist (M. Simon himself) and the engraver. The figures, not too small, are yet remarkably clear, and all the minute points of form, structure, and pattern, are exceedingly well defined. One only regrets that the number of species illustrated should be, perhaps

necessarily, so limited; a type only of each genus being represented, with some few structural details of others. Figures, such as those here given, of all the species comprised in the work, would make it one of the most valuable and important faunistic works on spiders that have been published for many years. In spite, however, of this, probably inevitable, drawback, we hail this volume with great satisfaction, not only for what it is in itself, but as an earnest of what we hope is to follow before any great lapse of time. A second volume, containing four more families—Urocteoidæ, Agelenidæ, Thomisidæ, and Sparassidæ—is announced for April next; and it is considered that four or five volumes in the whole will complete the work.

#### ANTHROPOLOGICAL NOTES AND QUERIES

*Notes and Queries on Anthropology, for the Use of Travellers and Residents in Uncivilised Lands.* Published by a Committee appointed by the British Association for the Advancement of Science. (London: E. Stanford, 1874.)

WELL asked is half answered, and more problems escape solution because no one happens to propose them, than because of their real difficulty. To suggest suitable inquiries to the mind of a traveller or colonist as to the wild races he comes in contact with, is to start him on a course of ethnological investigation which may lead to excellent results. The plan of drawing up lists of such inquiries to be distributed among naval officers, missionaries, and others, is not new. The Ethnological Society of London issued a set years ago, which drew much information. An elaborate series of questions as to the North American tribes, answers to which constitute some of the best material in Schoolcraft's "Indian Tribes of the United States," is reprinted at the end of vol. i. of that work. The "Admiralty Manual of Scientific Inquiry" contains an ethnological section, first drawn up by Dr. Prichard, and since revised. The present publication issued by the British Association is far more complete than any of these earlier guides. The committee by whom it has been drawn up are Col. Lane Fox (secretary) Dr. Beddoe, Mr. Franks, Mr. F. Galton, Mr. E. W. Braubrook, Sir J. Lubbock, Sir Walter Elliot, Mr. Clements R. Markham, and Mr. E. B. Tylor. The first sections, relating to the physical constitution of man, are drawn up by Dr. Beddoe, who gives drawings and directions for measurement of skull and limbs, &c. It adds much to the value of the book that the eminent French anthropologist, Dr. Broca, has allowed his set of colour-types to be reproduced. By the aid of these tinted patches, the colour of skin, hair, and eyes in individuals of any race may be set down within a shade. Thus, instead of loosely describing a Peruvian Indian's complexion as copper-brown, it might be defined as between No. 42 and No. 43 of Broca's table. The section on archæology is by Col. Lane Fox, and contains cuts of the principal types of stone implements, contributed by Mr. John Evans, also an ideal representation of a valley, to show the position of the gravel beds above the present river-level, where travellers may be likely to find drift-implements. The sections on war, hunting, and ornamentation are also by Col. Fox; the latter article is especially interesting from the illustra-

tions of the principal patterns used in barbaric ornamental carving, &c., such as the chevron, fret or key-border, plait or guilloche. Mr. Franks deals with the subjects of clothing, personal ornaments, pottery, &c.; Mr. Evans with weaving, basket-work, &c.; Mr. Galton with statistics; Sir J. Lubbock with relationships; Mr. Tylor with religion, mythology, language, customs, &c.; Prof. Busk with artificial deformations; Prof. Carl Engel (whom the printer has copyretted into *Cave Engel*) on music; Mr. Hyde Clarke on weights and measures, money, &c. The articles often contain not only leading questions, but introductions which state in few words what is known on their subjects.

We strongly recommend those who have friends within reach of uncivilised countries to send them out at once copies of this little manual. Being not a regular trade publication, but issued by a scientific body, it may very likely fall out of print when the first stock is exhausted.

#### OUR BOOK SHELF

*Lessons in Elementary Botany.* New Edition. By D. Oliver, F.L.S., F.R.S. (Macmillan and Co., 1874.)

THE new edition of this admirable little text-book deserves a word of notice. It is slightly enlarged, the additions principally dealing with the most important points in economic botany. The illustrations have been increased in number, and the few small errors which had crept into the first edition have been corrected. In the present state of our classificatory knowledge of flowering plants, it would be hardly possible to have a better guide than Prof. Oliver's "Lessons." Something, doubtless, will still have to be supplied by the oral instruction of the teacher. No series of natural objects ever was or ever will be quite comfortable when packed into a classification. The exposition of the term *perigynous*, for instance, requires that the pupils should be not exacting, but reasonable; there have been found even grown-up and advanced botanists who have allowed themselves to be sceptical about the application of the term to the corolla of the common Holly. They have even ventured to go so far as to wonder how the insertion of the corolla would differ in this case if it were *hypogynous*.

The few pages at the end of the book devoted to Cryptogams have been slightly enlarged, but are still not perhaps intended to more than indicate the existence of other types of vegetable life besides Phanerogams. If the criticism may be allowed (and it really seems ungracious in a case like the present), it would have been better not to apply the term Order to groups differing so widely in their relative diversity as, say, *Cyperaceæ* and *Gramineæ* on the one hand, and *Musci* and *Fungi* on the other. On no possible modern classificatory principles can such aggregates of organisms be regarded as equipotent or comparable. Then *Lichenes* can hardly be said to hold up its head as a distinct group with the same unimpeachableness that was the case five years ago.

#### LETTERS TO THE EDITOR

[The Editor does not hold himself responsible for opinions expressed by his correspondents. Neither can he undertake to return, or to correspond with the writers of, rejected manuscripts. No notice is taken of anonymous communications.]

On the Northern Range of the Fallow Deer in Europe

THE essay, illustrated by woodcuts, on the existence of the Fallow Deer in Pleistocene times in England, in *NATURE* (vol. xi. p. 210), leaves no room for doubting that the antlers named in the books *Cervus brovonii* and *Cervus somonensis*,

really belong to a variety of the living Fallow Deer. And I thank its author, Sir Victor Brooke, for having brought forward evidence on the point which is not presented by any of the large series of recent antlers known to me in the British and Continental Museums, and without which I could not venture to identify the fossil with the living form. He has supplied the missing link hitherto sought in vain, and thereby removed two synonyms from the bulky catalogue of fossil mammalia. This identification, however, as I have already remarked in NATURE (vol. xi., pp. 113, 114), has little, if anything, to do with the further question, raised by Drs. Jettles and Sclater, as to whether the Fallow Deer now living in Northern and Central Europe was introduced—like the horse into South America—by the hand of man; and on this point I am glad to find my views shared by so high an authority on the Cervidae as Sir Victor Brooke.

W. BOYD DAWKINS

Owens College, Jan. 16

### The Habits of the Belted Kingfisher (*Ceryle alcyon*)

IN NATURE, vol. vii. p. 362, I made the assertion that I had "never seen a kingfisher take its food otherwise than by swallowing it whole, while yet upon the wing," and therefore questioned the truth of the remark made by Mr. Darwin, that kingfishers, having caught a fish, "always beat it until it is killed." The truth of my assertion was doubted by them, and being assured by careful observers that Mr. Darwin's remark did apply to our species, I determined to very carefully study the habits of the bird in question, and have taken every opportunity possible, during the past two years, to familiarise myself with the daily routine of its life. The following is the result:—In 1873 my opportunities were exceptionally good for observing the movements of a pair of these birds, inasmuch as the whole season through—from April to November—was spent upon the water, studying our freshwater fishes. My daily record of observations mentions my watching the kingfisher while feeding, from one to four times a day for eighty-three days—an average of twice a day, or 166 dives for fishes, witnessed; and either every plunge was unsuccessful, or the bird swallowed, before alighting, every fish he had taken. It is to be presumed, of course, that occasionally the bird missed his prey. At the close of the season, therefore, I felt satisfied that I was correct in my assertions; but, as one of our best ornithologists has said, "the horizon of one man is at the best very limited, and many ornithological facts occur that are not dreamed of in his philosophy;" and so, on mentioning the results of my seven months of observation to a careful observer of our birds, and finding that he sided with Mr. Darwin, I determined to repeat my observations, and have done so through the spring, summer, and early autumn of the present year. My opportunities were equally good, and, very much to my own satisfaction, I have a different result to give. It is proper to state here, that during the summer of 1873 my observations were made altogether in one locality, upon one stream—the summit level of a canal—and confined to one pair of birds. During the present year I watched the kingfishers in several widely differing localities. My note-books make mention of this bird from two to six times in a day, for 101 days—about 400 observations; and of this series, eighty-eight instances are recorded of seeing the kingfisher capture, and, on alighting, deliberately beating the fish against the limb on which he stood, and then swallowing the *butchered* fish. This is a long way from being a constant habit of the kingfisher; less than one-fourth of the fish taken being killed previously to being swallowed. There is, of course, some cause for both habits occurring, and I believe it is to be explained in this way:—

As already stated, my observations during 1873 were confined to one pair of kingfishers, and to the one locality they frequented—the summit level of the Delaware and Raritan Canal—and the obvious reason of the kingfishers always swallowing their prey as soon as caught was simply that they fed exclusively on the smaller cyprinoids frequenting that sheet of water. I know, of my own fishing experience (pursued after a different manner from the kingfishers, however), that millions of cyprinoids are found there, as though they sought there an asylum from the attacks of predatory fishes.

During the season just past, I took notes on such kingfishers as were seen about two creeks, a mill-pond, and the Delaware River. In each of these localities large fishes of many kinds are more or less abundant, and the percentage of small cyprinoids—from two-and-a-half to three inches long—being much less than in the canal, it would evidently be irksome to so voracious

a bird as the kingfisher to wait until some fish, the proper size for swallowing without preliminary, butchering, should come within reach.

It therefore seems to depend largely upon the size of the captured fish, whether or not it is killed by the kingfisher before being swallowed.

On examination of my note-books I find also that when the parent birds had young in the nest, or while the hen-bird was upon her eggs, the male bird was most frequently seen to carry a fish in his beak to some convenient perch, and there kill and divide it. This appeared to be the manner of proceeding when the parent bird purposed feeding its mate or the young; being able, I judge, to disgorge a fragment of a larger fish, but not to eject an entire fish.

Both habits having been found to be true of this bird—that of swallowing the fish when caught, and of killing it before eating it—it is desirable to know why the latter method should be the rule, almost without exception, in some localities. I can only suggest that this may depend upon the anatomical characteristics of the fishes caught by the kingfishers. When an abundance of cyprinoids—soft-finned fishes—are to be obtained, then little or no preliminary carving on the part of the birds is necessary; but if young acanthopterygians, and tough, hard-scaled fishes of any family, have to be depended upon, then the kingfisher will be careful to first kill and pull in pieces such fishes, that unsuitable portions may be rejected. I have a memorandum of one instance where a young gizzard shad (*Dorosoma cepedianum*) was beheaded and divided into four portions before the kingfisher ate it.

In studying the habits of our American birds—and I suppose it is true of birds everywhere—it must at all times be remembered that there is less stability in the habits of birds than is supposed; and no account of the habits of any one species will exactly detail the various features of its habits as they really are, in every portion of the territory it inhabits.

Trenton, New Jersey, Nov. 20

CHAS. C. ABBOTT

### Kirke's Physiology

IN Kirke's "Physiology" (p. 128, 7th edition) mention is made of a conception, due to Mr. Savory, concerning a probable function of the Sinuses of Valsalva, which appears to me to be based on a neglect of an important hydrostatic law. And as this error is not only widely spread, but is considered a point of some importance among students of physiology, it may not perhaps be unwise, even now, to call attention to it. It is stated that, owing to the expansion of the aorta towards its termination, part of the force of the reflux of the column of blood is sustained during diastole by the muscular substance of the ventricle. Now, it seems that a consideration of the law above referred to, which is known as Pascal's "Principle of the Equality of Pressures," must essentially modify this statement. It will be well to note, however, before tracing its application, that notwithstanding the varying mechanical conditions of the column, and the structures in relation with it, these conditions at any one point of time during dilatation may be regarded as fixed and invariable. Also, that as these conditions vary in degree and not in kind, what is true of any one period of time must, in so far as the present demonstration is concerned, be true of any other.

Let us consider the state of things immediately upon the conclusion of the systole. Firstly, the whole arterial system is in a state of distension, and, in virtue of its elasticity, tends to contract and to impel the blood in two directions—onwards through the capillaries, and backwards against the heart. There is also a cessation of the opposing impulsive force from the ventricle, and the combined effect of these two actions is to produce the "force of reflux." And since, as has been shown above, it is unnecessary to trace the variations due to the mobility of the system through the whole period of dilatation, it may be said that at any given instant we have the following data, viz., a column of fluid contained in a vessel with an expanded base, and a certain force impressed upon that column. It is obvious that it cannot affect our conclusions to assume that the force of reflux is transmitted to an imaginary surface, which we can fix at a point immediately above the expansion of the vessel, where it attains its normal calibre, and we can then ascertain how this force is further transmitted to the base. This base is, however, made up of two parts, a circumferential part by the muscular substance of the ventricle, and a central part by the semilunar

valves, the whole area being greater than that of any other section of the column. Now, the question at issue is, whether by this arrangement the semilunar valves bear any less pressure because a portion of the base of the column rests upon the wall of the ventricle. That they do not may be sufficiently proved by the following considerations.

It is a generalisation from Pascal's law that "when a liquid enclosed in a vessel is submitted to an external pressure, every plane surface that we can imagine in the interior of the vessel experiences a pressure proportional to its area." As a consequence of this law, it follows, if the force impressed upon our imaginary surface represent the total force of reflux, that the pressure sustained by the whole area of the base will be considerably greater than the actual force of the column, and this increase of pressure will be proportional to the difference between the areas of the two surfaces. Also, the pressure upon the semilunar valves will be entirely independent of the pressure upon the rest of the base, and will be directly proportional to their own extent. It may be concluded, therefore, that whatever the condition of things at the base of the aorta may be, no mechanical advantage is gained thereby; indeed, if the area of the valves be equal to that of the surface we have taken, they will sustain a pressure equal to the total force of reflux of the column. Hence, by extending the area of the base over the wall of the ventricle, the only effect is to increase the total amount of pressure sustained, without at all lessening the pressure upon its original extent.

It is true that if the aortic orifice contract with the muscular substance of the ventricle, that in this way, *i.e.* by decreasing the area of the valves, a varying amount of advantage would be gained which would be greatest at the time of greatest contraction. This condition is, however, the only one that can at all favour the idea that "the reflux is most efficiently sustained by the muscular substance of the ventricle," and as this condition is doubtful, it must still seem that the main feature of Mr. Savory's theory cannot be supported.

W. PERCY ASHE

#### Phœnician Characters in Sumatra

In a short communication to the Anthropological Institute in December last (*NATURE*, vol. xi. p. 199), Phœnician characters were stated by me to be still in use in South Sumatra. As many of your readers may be glad to have more information on the subject, I write to say that the district above alluded to includes Rejang, Lemba, and Passammah, between the second and fifth parallels of south latitude. Several manuscripts, on bamboo, from this region are preserved in the library of the India Office; and a Rejang alphabet is given by Marsden in his "History of Sumatra," third edition. Some of his characters, however, appear to have been incorrectly copied. About half the Rejang letters are admitted by all the Oriental scholars to whom I have shown them to be Phœnician of the common type; others being similar to forms found in Spain and other Phœnician colonies. Most of the letters are *reversed*, a peculiarity which is explained by the fact that the Rejang writing, according to Marsden, is read from left to right, contrary to the practice of the Malays generally. The matter is of great interest, and it is to be hoped, will be investigated by Phœnician scholars.

J. PARK HARRISON

#### Ring Blackbird

In my letter in *NATURE*, vol. xi. p. 187, I did not refer to the Ring Ousel, for it did not occur to me that anyone would suppose that, with the apparatus of so many standard works on birds, I could fail to identify my bird, if he were a Ring Ousel, male or female. I therefore add that my bird is in no respect (save the prevailing colour) like that species of *Turdus*. It is *exactly* like a female blackbird, save that it has a white ruff, in the position of the Barbary Dove's ring, and white spot under the chin. I have never seen a Ring Ousel, or the picture of one, with those characteristics. Besides, the Ring Ousel is migratory, and would hardly be seen till the spring.

Athenæum Club, Jan. 16

C. M. INGLEBY

[Considering the time of year at which this specimen was obtained, it is more probable that it is a pied variety of the blackbird (which is far from uncommon) than a Ring Ousel. If our correspondent will forward the specimen to us, for examination, we will settle the point for him, and return it.—Ed.]

#### OUR ASTRONOMICAL COLUMN

THE TOTAL ECLIPSE OF THE SUN ON APRIL 6.—Dr. Janssen's station for the observation of this eclipse is mentioned as probably Hué, the position of which place, as laid down on the Admiralty Chart of Cochin China, is in longitude  $107^{\circ} 38'$  east of Greenwich, and latitude  $16^{\circ} 29'$  north. For this point the *Nautical Almanac* elements give the following figures:—

First contact at 1h. 38m. 6, local mean time,  $130^{\circ}$  from the sun's N. point towards the west, for direct image. Totality begins at 2h. 57m. 2s., and continues 3m. 12s., the sun at an altitude of  $46^{\circ}$ .

ENCKE'S COMET will no doubt be within reach as the moon withdraws from the early evening sky. The positions subjoined are reduced to 8h. Greenwich time from the ephemeris of Dr. von Asten, of Pulkova, published by the Academy of Sciences of St. Petersburg:—

		R.A.	h.	m.	s.	N.P.D.	DISTANCE.
1875—Jan.	24	23	23	31		$85^{\circ} 40' 6''$	1'989
	"	25	—	24	53	$85^{\circ} 32' 9''$	
	"	26	—	20	16	$85^{\circ} 25' 0''$	
	"	27	—	27	40	$85^{\circ} 17' 0''$	
	"	28	—	29	6	$85^{\circ} 8' 8''$	1'977
	"	29	—	30	33	$85^{\circ} 0' 4''$	
	"	30	—	32	2	$84^{\circ} 51' 9''$	
	"	31	—	33	31	$84^{\circ} 43' 3''$	
Feb.	1		—	35	2	$84^{\circ} 34' 5''$	1'961
	"	2	—	30	34	$84^{\circ} 25' 5''$	
	"	3	—	38	8	$84^{\circ} 16' 4''$	
	"	4	—	39	43	$84^{\circ} 7' 1''$	
	"	5	23	41	20	$83^{\circ} 57' 6''$	1'940

Mr. Otto Struve writes that Dr. von Asten's calculations show the last three revolutions of this comet can be perfectly represented by a uniform mean motion, without the hypothesis of a resisting medium, and even with greater precision than all the previous observed returns with that hypothesis. At the same time, during more than one revolution, something like acceleration has been indicated, and nearly to the same amount as Encke had supposed. This was the case between 1862 and 1865. Again, in other revolutions, as between 1845 and 1848, the acceleration has been subjected to very considerable changes. In the actual state of his researches Dr. von Asten is inclined to conclude that the existence of a resisting medium is not proved by the motion of Encke's comet, and that the observed acceleration in several returns ought to be attributed to the action of other forces; for instance, repulsive power produced by the approach of the comet to the sun, the effect of which might vary considerably, according to the conditions in which the return to perihelion takes place. A short paper by Dr. von Asten on this interesting subject is in the press.

WINNECKE'S COMET OF SHORT PERIOD, last visible in 1869, will also be observable in the morning sky from about the next new moon. The ephemeris calculated by Prof. Oppöler of Vienna will be found in No. 2,016 of the *Astronomische Nachrichten*. This comet will probably be faint, while it remains visible at the present return. It arrives at perihelion on March 12, and at its least distance from the earth on February 15. It is Comet 1819 (3), and Oppöler thinks he has identified it with one of the imperfectly observed comets in 1808. The elements which have been determined for 1875 show that the comet now makes a very close approach to the orbit of Jupiter; indeed, in heliocentric longitude  $109^{\circ} 25'$ , the distance between the two orbits is less than 0.06 of the earth's mean distance from the sun; this point is passed rather less than two years before perihelion passage. So far as can be judged at present, the comet will not be liable to great perturbation from the attraction of Jupiter till the year 1907, when it is possible a complete

change of elements may take place; this, however, of course depends upon the amount of change which the actual mean motion may undergo, from the successive smaller perturbations of the next thirty years.

**BORRELLY'S COMET OF DECEMBER 6.**—Thus far it does not appear that any orbit of the last comet discovered at Marseilles has been published. The following elements, founded on observations between Dec. 7 and 26, received from M. Stephan, Director of that Observatory, may therefore possess some interest:—Perihelion passage, Oct. 19, 1874, at 4h. 36m. Greenwich time; ascending node,  $282^{\circ} 12' 49''$ ; distance of perihelion from node, counted on the orbit in the direction of motion,  $15^{\circ} 23' 34''$ ; inclination,  $80^{\circ} 56' 28''$ ; distance in perihelion, 0.49665; motion, retrograde. These elements bear no close resemblance to those of any previously computed comet.

#### ON A PROBABLE CAUSE OF THE CHANGE OF THE COURSE OF THE AMÚ DARYA FROM THE CASPIAN TO THE ARAL\*

[F the central regions of Asia are really, as is surmised, the localities where the youth of the human race was passed, agriculture, aided by irrigation, has probably been practised from the earliest ages on the banks of the Oxus.

The description, in Herodotus, of the plain in Asia through which a mighty river called Aces ran and watered the lands of five nations inhabiting its banks, may possibly not apply to the Oxus valley, though the Chorasmians are specified as one of the five nations. But the passage clearly describes the distribution of the waters of the Aces for the purposes of cultivation, and it may with reason be inferred that the art of irrigation was in vogue in the Kharezmian oasis some two thousand years ago. However this may be, the Chinese traveller Hiouen-tsang speaks of Khiva, in the seventh century of our era, as forming but a narrow band on both banks of the Oxus; a description which does not admit of a doubt that the waters of the river were then employed in watering the land.

At the present day the Khanate of Khiva, as is well known, owes its fertility to the numerous canals of irrigation derived from the Amú, between Pitnak and Nukus. The heads of these artificial canals are kept open during the part of the year included between the months of May and November, and thus allow the summer or flood waters of the river, which pass into them, to be distributed over the land of the Khanate. As the volumes and velocities of the streams entering the several canals are less than that of the flood of the Amú, a deposition of silt, carried in suspension by the waters, takes place in these canals. For this, among other reasons, their heads are closed during the winter and early spring months, so as to allow of their running dry, and the deposited silt being then cleared, by manual labour, from their beds.

I am not aware that even a rough estimate has ever been made of the quantity of water thus diverted from the Amú, and passing into these canals, during the period of the yearly floods. It is clear, however, that the physical phenomena of a river must be sensibly affected by the abstraction of so large a body of water from its stream, and I will, therefore, make some attempt to arrive at an approximation to the truth on this head, though the data at my disposition are insufficient, and the conditions of the problem are such as render it difficult to attain to any great precision.

The land under cultivation in the Khanate is generally estimated at about two millions of acres; if we assume that the whole of this cultivation requires the constant use of water, about 40,000 cubic feet per second must be taken by the several canals from the river. It is perhaps true that many of the crops do not require more than partial irrigation, but, on the other hand, the population of about 400,000 souls, and the cattle of the Khanate, are entirely dependent on the river for their water supply. The excess, therefore, assigned for irrigation may be considered as absorbed by the people and by the cattle, and the estimate of 40,000 cubic feet per second may be allowed to stand for the present.

A very rough calculation, founded on the scanty data to be found in General Ivanien's pamphlet on Khiva, and made by me some four months ago, gave 30,000 cubic feet per second as the quantity of water diverted from the Amú by the irrigation canals. It is to be remarked, however, that the few dimensions given of these canals are merely founded on hearsay evidence, and are not the result of actual careful observation, and they refer, moreover, to the state of things which existed forty years ago. No correct estimate can be expected to be deduced from such confusedly general and incomplete information. It results, then, that the first estimate of 40,000 cubic feet per second, founded on the known necessities of the land and its population, is probably nearer the truth than the second, which I derived from a perusal of General Ivanien's interesting pamphlet.

It has already been said that the heads of the canals remain open during the flood season of the Amú; the quantity of water, consequently, entering the canals, depends upon the height of the summer floods of the river, and will be greater as the level of the flood is higher, and will be less as that level is lower. But since a supply of about 40,000 cubic feet per second is a matter of actual necessity to the lives of the population of the Khanate, it is clear that the levels of the canal beds, at their heads, must be so adjusted as to provide for the entry of 40,000 cubic feet per second, even should the level of the Amú flood be an exceptionally low one. It results, therefore, that in all years, except that of an exceptionally low flood, a much greater quantity of water than what is actually required for irrigation and for consumption by the population and by the cattle is diverted from the Amú, and passes by the irrigation canals of Khiva. Ivanien mentions that the excess of water passing by the canals during high floods is allowed to flow into lakes and into the Doudon, Kunya Daryalik, and other old dry beds of the Amú, which thus act as safety-valves to the embankments and works belonging to the irrigated tract. The conclusion which may be drawn from the foregoing is, that in most years there is a very great waste of water arising from the imperfect system of irrigation employed in Khiva. It is needless to enlarge on the magnitude of such an evil in a locality where water is an absolute necessity to prevent the advance of the surrounding desert. With a scientific system of irrigation, it is probable that an acreage of land equal to that at present cultivated on the banks of the Amú might be reclaimed from the desert, by precisely the same expenditure of water which now takes place.

The following table, which I have ventured to compile from the measurements and observations of the Amú Darya made by the officers of the expedition sent in 1874, under the auspices of the Imperial Russian Geographical Society, will enable some idea to be formed of the waste of water which took place on several dates between the 23rd of June and the 10th of September of the year in question. The table shows, in cubic feet per second, the total discharge of the river, the portion of that discharge diverted by the irrigation canals, and the remainder which passed Nukus. I must, however, remark that the quantities shown should be regarded as an approximation only to the truth.

Date, New Style.	Volume of River.	Volume passing Nukus.	Volume entering Canals.
23rd June ...	101,000	47,800	53,200
29th " ...	97,900	46,300	51,600
11th July ...	139,800	66,200	73,600
17th " ...	122,600	58,000	64,600
3rd August ...	142,800	67,600	75,200
15th " ...	120,700	57,200	63,500
25th " ...	106,000	50,200	55,800
10th September...	93,100	44,100	49,000
Average per diem	122,200	59,600	62,600

These figures show that in lieu of 40,000 cubic feet per second, which is the water supply estimated to be sufficient for the wants of the Khanate, the irrigation canals, between the 23rd of June and the 10th of September, 1874, diverted, on an average, 62,600 cubic feet per second from the Amú Darya, or ten-ninetyths of the whole volume of the river.

Information does not yet exist which would allow more than a guess to be made of the volume of the low-water discharge of the Amú, but from what has been already stated, it follows that at Nukus there is a very much less difference between the

\* Presented to the Imperial Geographical Society of Russia, December 4, 1874; read at the monthly meeting of the Society, December 16, 1874.

volumes of the summer and winter discharges than there would be if the river were in a state of nature, and if a large portion of its flood-water were not diverted by man for the purposes of irrigation. This equalisation between the summer and winter discharges of the Amú, below the irrigated tract, has great significance, and has suggested to me a cause which may probably account for the change in the course of the river from the Caspian to the Aral. It is a matter of notoriety that the waters of the Amú carry in suspension an enormous quantity of mud and sand, and it is to the deposition, in its old bed, of this suspended matter, that I am inclined to think the change in the course of the river may with much probability be ascribed.

In speaking of the aqueous causes of the changes taking place on the surface of the earth, Sir Charles Lyell, in his "Principles of Geology," has made the following remarks on the transporting

power of water. As they cannot be put in plainer and better language, and as they bear intimately on the theory I have hazarded, I will quote them verbatim and *in extenso*:—"The force," he says, "of mountain torrents is easily understood; but a question naturally arises, how the more tranquil rivers of the valleys and plains, flowing on comparatively level ground, can remove the prodigious burden which is discharged into them by their numerous tributaries, and by what means they are enabled to convey the whole mass to the sea. If they had not this removing power, their channels would be annually choked up, and the valleys of the lower country and plains at the base of mountain chains would be continually strewn over with fragments of rock and sterile sand. But this evil is prevented by a general law regulating the conduct of running water: thus, two equal streams do not, when united, occupy a bed of double sur-

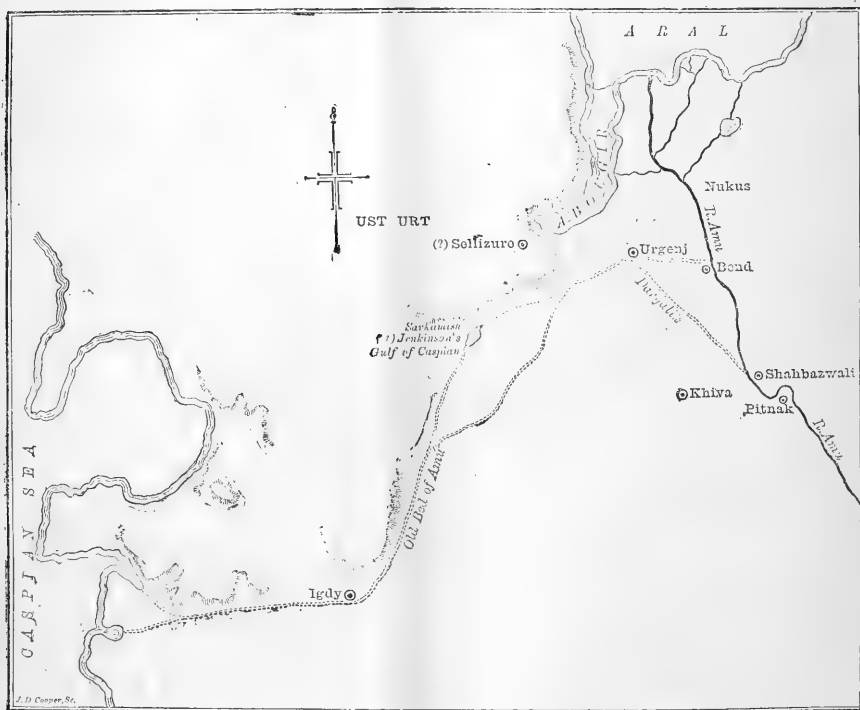

face. Nay, the width of the principal river, after the junction of a tributary, sometimes remains the same as before, or is even lessened. The cause of this apparent paradox was long ago explained by the Italian writers, who had studied the confluence of the Po and its feeders in the plains of Lombardy. The addition of a smaller river augments the velocity of the main stream often in the same proportion as it does the quantity of water. The cause of the greater velocity is, firstly, that after the union of two rivers, the water, in place of the friction of four shores, has only that of two to surmount; secondly, because the main body of the stream, being further distant from the banks, flows on with less interruption; and lastly, because a greater quantity of water, moving more swiftly, digs deeper into the river's bed. By this beautiful adjustment the water which drains the interior country is made continually to occupy less room as it approaches

the sea, and thus the most valuable part of our continents, the rich deltas and great alluvial plains, are prevented from being constantly under water."

Now, if we apply these principles to the Amú Darya, it is manifest that, when it fell into the Caspian, the conditions of its flow were such that the volume and velocity of its summer or flood-stream were sufficiently great to clear its bed annually of the deposition of silt due to the smaller volume and velocity of its winter stream. The figures given in the table show that the volume of water passing Nukus on the 10th of September was a little more than one-third only of the total discharge of the river on the 3rd of August, on which date, it is probable, the Amú Darya reached its maximum height for 1874. I am inclined to think, from a consideration of the winter discharges which are recorded by Wood in his work on the Upper Oxus,

that the minimum volume of water passing Nukus during the winter months of any year is not very much less than that which passed the same point on the 10th September, 1874. However, it is impossible, in the present state of our information, to state with precision either the volume of discharge during the winter months, or the quantity of water required to pass during the summer, to scour out the deposits made in the bed of the Amú by the winter discharge. But those who are inclined to confide in the intelligent arrangements of nature, will have no difficulty in believing that these two volumes were in such a state of proportion as corrected the evils induced in the bed of the river by the low velocity of the smaller of the two volumes, *i.e.* of the winter discharge of the Amú. Under such circumstances, the bed of the river would be undeteriorated, its course would remain constant, and its flow would continue into the Caspian Sea.

But immediately the volume and velocity of the summer or flood discharges of the Amú Darya were decreased by the action of defluent canals excavated for the irrigation of the lands of Khiva, the compensatory arrangements of nature, which previously kept the river's bed clear, would be interfered with, and some portion of the silt deposited by the winter stream would remain unremoved. This evil would increase yearly, and the intensity of its action would be greater as the quantity of water diverted for irrigation purposes became greater. A portion of the deposit might occasionally be removed by an accidentally high flood, but, eventually, a state of things would supervene in which the conditions of the Amú would present the precise converse of the state of adjustment described in Sir Charles Lyell's work; that is to say, bars and banks of sand would form in the course of the river, would be enlarged yearly, and would prevent it from flowing on to the Caspian. The most westerly point reached by the waters of the river would continually recede to the east, and they would become erratic while seeking an outlet by a slope steeper than that of their encumbered old bed.

Such is a tolerably concise description of what I conceive has actually occurred in the case of the Amú, and has caused the change of its flow into the Aral Sea; and it now remains to examine whether such facts as are known regarding the change and the existent state of things are in harmony with the theory I have ventured to hazard.

Abulgazee Khan, in his history of the Mogols and the Tartars, relates that in the early part of the sixteenth century "all the road from Urgen] as far as Abul Khan was covered with aouls, *i.e.* encampments of nomads; for the Amú Darya, after having passed under the walls of Urgen], flowed to the foot of the eastern slope of Mount Abul Khan, whence the river turned to the south-west, to turn afterwards to the west, and empty itself at Ogourtcha into the Sea of Mazanderan. The two banks of the river as far as Ogourtcha presented a succession of cultivated lands, of vineyards and of orchards. . . . All that country was at that time very populous and in the most flourishing condition." In the early part of the sixteenth century, therefore, the Amú Darya fell into the Caspian, and irrigation, by means of its waters, was general along its banks from Urgen] as far as Abul Khan.

Anthony Jenkinson, the Englishman travelling from the Caspian eastwards in A.D. 1559, arrived on the 5th October at what he called a "gulle of the Caspian Sea." Here he found "the water very fresh and sweete." He continues: "Note that in times past there did fall into this gulle the great river Oxus, which hath his springs in the mountains of Parapomusis, in India, and now cometh not so far, but falleth into another river called Ardok, which runneth towards the north. . . ." The "very fresh and sweete water" found by Jenkinson could only have been brought by a flood, or have forced its way either by a channel or by filtration through the sand-banks into the old bed of the Oxus to the spot in question. At the date mentioned, therefore, by Jenkinson, some of the waters of the Amú Darya could still find their way to the Caspian, and the opening of the new course into Ardok, and the closing of the old course, must have been circumstances of tolerably recent occurrence.

Jenkinson continues his narrative thus:—"We, having refreshed ourselves at the forsaid gulle, departed thence the 4 day of October (either this or his first date, therefore, is a mistake), and the seventh day arrived at a Castle called Sellizure. . . . The Castle of Sellizure is situated upon a high hill. . . . The south part of this Castle is lower land, but very fruitful, where grow many good fruites. . . . the water that serveth all that country is drawn by ditches out of the river Oxus, unto the great destruction of the said river, for which cause it falleth not into the Caspian Sea as it hath done in times past, and in short time, all that land

is like to be destroyed, and to become a wilderness for want of water, when the river of Oxus shall fail."

This apprehension was soon to be realised, for Abulgazee relates, in the work already quoted from, that thirty years before his birth, *i.e.* in A.D. 1575, the Amú Darya found a passage for itself into the Sea of Aral; a circumstance which changed the environs of Urgen] into a desert by depriving them of the water necessary for the irrigation of the soil.

From the foregoing extracts we learn that, commencing with some year early in the sixteenth century, the stream of the Amú Darya, year after year, fell short of reaching as far to the west as it formerly did, until in A.D. 1575 the new channel into the Aral conveyed the whole of the waters which remained after the irrigation of the lands of the Khanate lying on the course of the river above Urgen] had been provided for.

As regards the actual condition of the old and present beds of the Amú Darya, the levelling operations carried out in 1873 and 1874 afford the following data:—

Height of Aral . . .	above Caspian	250 feet.
" Igdý . . .	" Caspian	190 "
" Nukus . . .	" Aral . . .	60 "
" Nukus . . .	" Caspian	310 "
" Bend . . .	" Aral . . .	70 "
" Bend . . .	" Caspian	320 "
" Shahbazwali . . .	" Aral . . .	140 "
" Shahbazwali . . .	" Caspian	390 "
Distance along old Amú from Caspian to Igdý . . .		200 miles.
" " " Urgen] . . .	" Igdý . . .	274 "
" " " Urgen] . . .	" Bend . . .	43 "
" " " Urgen] . . .	" Shahbazwali	133 "
" " " Urgen] . . .	" Nukus . . .	17 "
The foregoing distances are taken along the meanders of the bed.		
Hence the slope per mile from the Caspian . . . to Igdý . . .		is 11 $\frac{1}{2}$ in. hes.
" " " " Urgen] . . . to Igdý . . .		" 3 $\frac{1}{2}$ "
" " " " Bend . . . to Urgen] . . .		" 3 $\frac{1}{2}$ "
" " " " Shahbazwali . . . to Urgen] . . .		" 8 $\frac{1}{2}$ "
" " " " Shahbazwali . . . to Bend . . .		" 9 $\frac{1}{2}$ "
" " " " Bend . . . to Nukus . . .		" 7 $\frac{1}{2}$ "

From the foregoing I infer Urgen] to be 56 $\frac{1}{2}$  ft. above Aral, and 306 $\frac{1}{2}$  ft. above the Caspian.

The following are the conclusions I draw from the foregoing data:—

1. That the old bed between Urgen] and Igdý, having the abnormally small slope of 3 $\frac{1}{2}$  in. per mile, has probably been raised by the deposit of silt carried by the waters of the river.

2. That the bed of the Kunya Daryalik, which commences opposite Shahbazwali, having a slope of 8 $\frac{1}{2}$  in. per mile above Urgen], discharged a larger body of water than the bed below that place. The difference of the discharges must have been disposed of in irrigation, and the abstraction of water from the Kunya Daryalik was the cause of the silt deposited in the bed of the river below Urgen], as well as of that in the Kunya Daryalik itself.

3. The bed of Kunya Daryalik having a slope of 8 $\frac{1}{2}$  in. per mile, while that of the present river, downwards to Bend, from the head of the Kunya Daryalik, has a slope of 9 $\frac{1}{2}$  in. it follows, that the slope of the old course must have been flattened from something steeper than 9 $\frac{1}{2}$  in. per mile to 8 $\frac{1}{2}$  in. per mile; otherwise, the waters of the river could have never passed by the Kunya Daryalik towards Urgen].

4. The water passing along the old Amú being headed back by the deposition of silt in the old bed of the river, became erratic during floods, and found an outlet by the Ardok channel, which eventually carried all the waters of the Amú Darya towards Nukus.

5. The small difference of slope per mile of the beds of the Kunya Daryalik, and the present Amú Darya, explains the tendency of the flood waters to escape from the river, and the necessity of the dams found along the old course. And since the slope of the bed of the Amú Darya down to Bend is 9 $\frac{1}{2}$  in. per mile, while that from Bend to Nukus is 7 $\frac{1}{2}$ , there must always be a tendency, during floods, for the waters to be headed back at Bend, and so to seek an escape by the Loudon channel, across the mouth of which a dam has been constructed to prevent such an occurrence. The condition of the bed of the Amú Darya, from where the irrigation canals commence, down to Bend, fully accords with the theory of the change of the course of the river developed in this note. Descending from the point indicated, the bed of the river is more and more encumbered



with shoals, until in the reach where Bend is situated, and where the maximum volume has been abstracted for purposes of irrigation, the entire breadth of the Amú Darya is obstructed by a mass of sandbanks intersected by narrow and tortuous channels.

It appears, then, that such information as we have, regarding the change and the existent conditions of the old and new courses of the Amú Darya, presents a picture precisely the converse of that delineated in and quoted from Sir Charles Lyell's work. In lieu of a constant increase to the transporting capacity of the waters of the river, we see that in the Amú Darya such is replaced by a constantly diminishing transporting power, and that the old bed has been filled up and destroyed by the deposition of silt. This deposition of silt and deterioration of the bed can only have been caused by the abstraction of its waters for irrigation. Whether other circumstances assisted the consequent change of the flow of the Amú Darya is a question it is not my purpose to examine in this place. Enough has, I would submit, been adduced to show that the practice of irrigation, as conducted on the banks of the Amú Darya, produces phenomena whose action furnishes a probable explanation of a very curious and interesting geographical problem. HERBERT WOOD

#### THE PARIS INTERNATIONAL CONGRESS OF GEOGRAPHICAL SCIENCE

THE meeting of the International Congress, of which we published the programme a few months ago (vol. x. p. 267), has been postponed, owing to the large number of demands from foreign parts for room in the Exhibition. It will not take place in the beginning of spring as intended originally, but will be opened on the 1st of August, perhaps by the President of the Republic, who seems to be deeply interested in the success of the enterprise. It will be held in the Pavillon de Flore. This magnificent building was left unfinished when the Empire was upset, and could not be burned by the Communists, as the woodwork had not been begun. It is now being decorated most tastefully, and will be inaugurated by the Congressionists.

An exhibition will also take place in the Pavillon de Flore and Orangerie situated close to the Place de la Concorde. All the Terrace du Bord de l'Eau, from the Pavillon de Flore to the Orangerie, will form part of the Exhibition. Temporary sheds of every description will be constructed in that splendid situation along the banks of the Seine and under the four rows of lofty trees. The *coup d'œil* will be splendid, and is sure to attract an immense number of spectators. The Exhibition will be opened on the 19th of July, and will last until the 4th of August. A very large number of gentlemen of all countries have been appointed members of the honorary committee. The president of the Congress is M. Delesse, a French engineer in the mining service, and a great geologist. M. Delesse is now the president of the Central Committee of the Geographical Society. Up to the present moment the vice-president has not been elected.

The Exhibition and Congress, as we formerly notified, have been divided into seven different groups: (1) Mathematical; (2) Hydrographical; (3) Physical; (4) Historical; (5) Economical; (6) Didactic; (7) Travels.

A programme of 123 questions has been published, and all these, as far as possible, will be discussed by the members of the Congress. The principal questions will be found in the article referred to.

#### ON THE ALTERATION OF THE NOTE OF RAILWAY WHISTLES IN TRAINS MEETING EACH OTHER

I AM not aware whether the following explanation of this curious acoustical phenomenon has ever appeared in print; if it has, it will, I think, bear repetition, as offering an interesting illustration of some of the laws of propagation of undulations through aerial media.

If two railway trains meet and pass each other at tolerable speed, and the driver of one of them is sounding his whistle, any person in the other train accustomed to music will notice that the moment the whistle passes him its note will be *lowered in pitch* in a marked degree.

It was at first supposed that, at the time of passing, the driver lowered his whistle intentionally, as a salute to the other train (like "dipping the ensign" at sea), but this was found not to be the fact, the driver himself being unconscious of any change. I believe the true explanation was first given by Mr. Scott Russell, but I do not know when or where.

It is an exactly parallel case to one which has recently attracted attention in astronomy, namely, the evidence afforded by the change in position of certain spectral lines, owing to the vapours which produce them approaching or receding from the observer. The explanation of this will be familiar to most of the readers of NATURE, and I have only to apply it to the case in question.

Every musical note propagates aerial waves succeeding each other with a known rapidity, corresponding to the pitch of the note; the higher the pitch, the greater the rapidity of succession of the waves, and *vice versa*. Now, when a person advances to meet these waves, more of them will pass him in a given time than if he stood still, on the same principle that if a man meets a file of soldiers on march, more men will pass him per minute than if he were stationary. Thus the apparently increased rapidity of the waves will give him the impression of a *sharper* note.

On the other hand, when the trains have passed each other, the listener will be moving in the same direction as the sound-waves, and consequently a *less* number will pass him in a given time, causing the note to appear *flatter*.

The sum of these effects will be the sudden *drop* of the pitch of the note at the moment the listener passes the whistle.

We may reduce the effect to numerical calculation, premising that, in order to simplify the reasoning, we will suppose the source of the sound to be stationary, and the observer to move towards it with a given velocity.

Let  $n$  = number of sound-waves propagated by the given note per second; and let  $n_1$  = the number which the listener will gain by his advance in the same time, which is the number he would pass by *his own proper motion* if the waves were standing still.

Then the effective number of waves per second which will meet his ear will be  $= n + n_1$ , this number determining the pitch of the note he hears. This may be called (by an astronomical analogy) the *apparent* pitch, as distinguished from the *true* pitch.

To find the value of  $n_1$ , let  $L$  = the length of the sound-wave ( $= \frac{V}{n}$  where  $V$  = velocity of sound in feet per second). Then, if  $v$  = velocity of motion of the listener he would pass, by his own proper motion,  $\frac{v}{L}$  waves per second; whence  $n_1 = \frac{v}{L} = \frac{n v}{V}$ .

Hence the apparent pitch of the note is what will correspond to the number of vibrations

$$= n + \frac{n v}{V} = n \left( 1 + \frac{v}{V} \right)$$

But we may simplify this by applying the harmonic principle, that a musical interval is measured by the ratio of the vibration numbers of its higher and lower limiting sounds. Let therefore  $\delta$  = the interval between the real and the apparent sound; then

$$\delta = \frac{n \left( 1 + \frac{v}{V} \right)}{n}$$

or  $\delta = 1 + \frac{v}{V}$  or  $= \frac{V+v}{V}$

A very simple formula, in which the original number of waves disappears, showing that the interval between the two notes is irrespective of the original pitch of the whistle, and depends only on the velocity with which the listener approaches the source of the sound.

We have now to take the case where the listener, having passed the whistle, is receding from the source of sound. The note will then appear flatter than the real one, and its vibration number will be found by the same rule as before, merely giving  $v$  a minus sign.

$$= n \left( 1 - \frac{v}{V} \right)$$

And the interval, i.e., the ratio of the vibrations of the higher to that of the lower, denoted by  $\delta_1$  will be

$$\delta_1 = \frac{n}{n \left( 1 - \frac{v}{V} \right)} = \frac{V}{V - v}$$

These two intervals added together will express the drop of pitch of the whistle at the time of passing.

But to add intervals together we must multiply their ratios; hence if  $\delta_2$  represent the drop,

$$\delta_2 = \frac{V+v}{V-v}$$

from which the drop of the whistle corresponding to any speed may be found.

To simplify the reasoning, we have supposed the whistle to be stationary and the listener to move with a velocity  $= v$ . If both move, as is the usual case in railway trains meeting,  $v$  must be made = the sum of the speed of the two.

Taking  $V = 1120$  feet per second for ordinary conditions, the following table shows the value of the drop for different speeds:—

Conjoint speed of the two meeting trains.		Corresponding drop of the note of the whistle.
Miles per hour.	Feet per second.	
24	34	A semitone $\left( \frac{16}{15} \right)$
45	66	A whole tone $\left( \frac{9}{8} \right)$
70	102	A minor third $\left( \frac{6}{5} \right)$
95	125	A major third $\left( \frac{5}{4} \right)$
120	160	A fourth $\left( \frac{4}{3} \right)$
152	224	A fifth $\left( \frac{3}{2} \right)$

I have made observations whenever I have had the opportunity, and find the results corroborate the deductions of theory. The most common interval observed in ordinary travelling is about a third, major or minor, corresponding to a speed of between thirty-five and forty miles per hour for each train. W. POLE

GLASGOW SCIENCE LECTURES

UNDER the title of the Glasgow Science Lectures Association, an organisation has lately been formed in Glasgow, whose object is to provide annual courses of

lectures on various branches of science by men of eminence in each department, so as to place in clear and comprehensive outlines the most important results of scientific inquiry before the public of Glasgow, and at such a rate as will secure to those who cannot otherwise obtain it the best information on the state of science, as established by the most recent investigations of its most distinguished workers. The scheme originated amongst a number of working men who were desirous of following the example of the science lecture movement which has been so successfully worked out in Manchester during the last six or seven years, but with this difference, namely, that the lectures should be self-supporting. To accomplish that end, and be in a position to pay the lecturers liberally for their services, they at once saw that the minimum rate of admission could not well be fixed at less than threepence, and they confidently believed that many of their fellows would be most willing to pay that amount for the privilege which it was proposed to place within their reach. They soon enlisted the sympathies and active co-operation of persons in a higher social sphere, and in due time the Association took active shape. A large executive committee was constituted, and Dr. Allen Thomson, F.R.S., one of the most distinguished members of the professional staff of the University of Glasgow, cheerfully accepted the honorary presidentship of the Association, while a number of other prominent citizens were enrolled in the list of vice-presidents.

Owing to the fact that Prof. Roscoe had been the moving spirit of the Manchester Science Lectures for the People, he was very early communicated with, in the confident hope that valuable advice based upon his practical experience would readily be placed at the service of the originators of the Glasgow lecture scheme. They were not disappointed in their expectations, and, indeed, had they been lacking in enthusiasm and determination to make the scheme a success, they would have been stimulated to action by the various communications which they received from that gentleman.

It was very late in the past year before the Glasgow Science Lectures Association was sufficiently well organised to make any public announcement of its existence; but the active promoters of the movement were most anxious not to allow the whole winter to pass without having some lectures delivered under the auspices of the Association, no matter how short the course might be. Prof. Roscoe most kindly and cheerfully consented to take part in the first or introductory course; and considering that gentleman's peculiar relationship to the Manchester Science Lectures, the committee came to the conclusion that no person could more appropriately assist at the public inauguration of the movement in Glasgow. Accordingly, with his consent, Prof. Roscoe was set down to deliver the opening lecture of the introductory course, and other three distinguished men of science were selected to follow him, namely, Sir William Thomson, Dr. W. B. Carpenter, and Prof. W. C. Williamson, of Owens College, Manchester.

The inaugural lecture was delivered on the evening of Friday, the 8th of January, and it was in every sense a most auspicious beginning. The Glasgow City Hall was chosen as the place for the delivery of the lectures, as the committee were desirous of bringing together the largest audiences that could be convened in any place of public meeting. It holds well-nigh three thousand persons, and on the occasion in question it was crowded. The reception given to the eminent lecturer was most enthusiastic. Dr. Thomson occupied the chair, and in introducing Prof. Roscoe to the meeting and formally opening the first course of lectures, he delivered an exceedingly valuable address, in the course of which he justified the formation of such associations as the one under whose auspices the lectures were to be given. He said that he had no doubt that in the selection of the lecturers the committee of the

Association would always keep in view the possession by the lecturers of those qualities which alone could secure ultimate success in their enterprise, and which might be summed up as follows:—First, the fulness of knowledge which belongs to an accomplished master of his subject; second, the authority in statement which is derived from original research; and third, the disposition and power to convey full and accurate information to others with simplicity and clearness.

The subject of Prof. Roscoe's lecture was "The History of the Chemical Elements," and it was most completely and successfully illustrated, especially in the department of spectrum analysis.

Sir William Thomson's lecture will be on "The Tides," in which it is expected that a full exposition will be given of the more important results arrived at by the British Association Tidal Committee in their recent investigations.

Dr. Carpenter has chosen as his subject "Man not an Automaton," with reference to the recent lectures of Professors Huxley and Clifford; and the concluding lecture, by Prof. W. C. Williamson, will be on "The Dawn of Animal Life."

It is the intention of the committee in future sessions to provide courses of eight or ten lectures, embracing all those branches of science that are susceptible of being treated thoroughly before large and miscellaneous audiences. What the public now want is lectures of the highest class, conveying ample information, but without unnecessary technicality and learned difficulty.

The success of the Manchester Science Lectures for the People and of the lectures delivered to the working men in the towns visited by the British Association during recent years, abundantly shows that such a desire is yearly becoming more and more prevalent.

JOHN MAYER

### ATLANTIC NOTES

#### Migration of Birds—The Thresher and Whale

IN crossing the Atlantic last September, when 900 miles distant from the nearest point of Newfoundland, two land birds settled on the ship, and after a short rest resumed their flight to the south-east, without partaking of the food which was scattered in various places for them. By the colour of their plumage and motion on the wing, I believe them to be a species of lark. It may well be asked whence did they come, and whither were they going over that vast space of ocean, with no resting-place nearer the continent than the Azores? How were they fed during their long journey, and what guided them on their course? for it is only reasonable to suppose they had come on a bee line from their starting point, and even then their muscular powers must have been severely taxed. It appears to me that naturalists are not in possession of the secret which enables birds of passage to go many days without food at a time when their system must be strained to its extreme limit of endurance.

From the result of close observation, I do not believe that land birds are often, if ever, driven to sea by the force of the wind. Some other cause must influence their movements. At the head of the Gulf of Bothnia, when there has not been a storm for many days, I have seen scores of different species around the ship, amongst them the hawk, the owl, the robin, and many others. Are those who alight and stay by the ship the stragglers from the ranks of the armies which annually migrate, the sick and worn who fall out by the roadside to die, whose end in creation has been fulfilled, and their places ready to be taken by the young and strong? This surmise is strengthened by the fact that no care can preserve the lives of these tired birds in captivity; the hawk and dove alike refuse food, and quickly pine and die.

Birds must possess strong affections, as they are always

seen in pairs on these long journeys, which is an additional argument in favour of their voluntary flight over the ocean. It is scarcely possible they could remain together in a gale sufficiently powerful to blow them off the land, and more unreasonable still to imagine that the strength which is able to carry them hundreds of miles without a rest should fail to breast an ordinary gale under the shelter of the land. Such facts as these vouch for the facility with which the most remote islands may increase the number of their species without the agency of man.

Off Youghal a gigantic thresher (*Squalus vulpecula*) was passed. It was leaping lazily and obliquely from the water, and after attaining its highest altitude, fell heavily on the surface, without making any effort to ease or guide its descent. This fish was not under fourteen feet in length; the belly of a pearly whiteness, and the back marked across with broad black bands. I have never seen this fish north before; but on the whaling grounds of the southern seas it is common. I do not believe it is dangerous to the life of the whale, as is often stated, but am under the impression that the irritation caused by the attacks of the thresher makes the animal vomit up the squid and other small matter on which it feeds. It is not reasonable to suppose that the blows inflicted by so small an instrument as the thresher's tail can have much effect through a foot of blubber. The whale has also many ways of escaping from its puny enemy; he dives to a depth where the thresher cannot follow, and if he could, his power of inflicting injury would be gone, owing to the resistance caused by the water; his speed also enables him to escape at all times. The treaty of offence which is said to exist between the thresher and sword-fish appears to me to be very mythical. When the whale is sick or dying, he is doubtless an object of attack to all the shark species, as they wage war with the whaler for the coveted blubber.

WM. W. KIDDLE

### THE TRANSIT OF VENUS

THE *Times* of yesterday contains some additional news from the Transit parties, specially those of France and Italy.

The French news consists of telegrams from Shanghai in the Northern and from New Caledonia in the Southern Hemisphere. From the former station M. Fleuriais, the astronomer in charge at Peking, now states that he was fortunate enough to observe all the four contacts, and not two only, as was at first stated. The times were as follows in local mean time:—First contact, 21h. 32m. 42s.; second, 22h.; third, 1h. 50m. 15s.; fourth, 2h. 17m. 13s. Nor is this all; no less than sixty photographs were taken which M. Fleuriais pronounces good. We have already stated that stations in Northern China are most useful for the application of the Halleyan and direct methods. From New Caledonia the best part of the news refers to the photographic operations, 100 good photographs being secured. Of the contacts, only the interior one at ingress was observed.

The news of the doings of the Italians comes from the party in Bengal, in charge of the distinguished spectroscopist Tacchini, including Dorna, Lafont, Morso, Abetti, and Tacchini. The telegram comes from Maddapore, and the party evidently occupied two stations. The first three observed all four contacts, the last two only the third and fourth.

As before stated, the chief instrument employed by the Italians was the spectroscope—an instrument not recognised in the equipment of any of the English parties.

The observations were of the most satisfactory kind, and the results may lead to a most important discovery in solar physics. The time of interior contact at egress was observed with the most rigorous exactness, both by the

ordinary telescopic method and by the spectroscopic method described in our former notes. It was found that the difference between the times of observation by these methods was *more than two minutes*, contact being observed by the spectroscope first. Now, if the contact had been observed last by the spectroscope, there was an obvious condition of the observation to which the discord might have been attributed; but there is now no room for doubt that the sun's extreme edge which we actually see in a telescope differs physically from the part just within it, although there is no difference to the eye—in fact, that it gives a spectrum of bright lines, while the spectrum of the true subjacent sun gives a continuous spectrum with dark lines. Further, the physical difference to which we refer would probably tend to make this stratum variable in thickness and luminosity. Nay, we may already hazard the question whether there is not here a condition which may have something to do with the various times of contact recorded by observers having object-glasses widely differing either in aperture or in the over- or under-correction of the chromatic dispersion.

Another victory achieved by the Italians is the determination of the nature of the atmosphere of Venus. The ring round the planet, which in the former transits as in the present one was visible round Venus both on and off the sun, indicates in the spectroscope that in that planet, as in our own, the atmosphere is composed to a certain extent of aqueous vapour.

Mr. Proctor pointed out some time ago the great value of photographs taken at the Cape of Good Hope in combination with those secured at Nertschinsk and Roorkee. We have no information that any photographs were taken at the Royal Observatory at Cape Town, but a correspondent informs us that fourteen successful photographs were taken at Cape Town, two of them showing distinctly the black drop.

The *Times* then refers to the final appendices to the "Recueil de Memoires, Rapports et Documents relatifs à l'observation du Passage de Venus sur le Soleil," as enabling us at length to refer to the doings of the Commission appointed by the French Government. The records extend from February 1869, when the Government first moved in the matter, to a few months ago, when the final instructions on the methods to be adopted to guard the observations against risk of loss were issued.

The first action of the French Government was to ask the Academy of Sciences to consider the places to be occupied, and the number of observers; the instruments to be used; the additional researches which might be undertaken by the observers sent to the Southern Hemisphere; and, finally, whether an Astronomical Congress would not be desirable to bring about a uniform system of observations.

A strong commission was at once appointed, composed of mathematicians, astronomers, physicists, and chemists, in order that the problem might be considered in an efficient manner. Strangely enough, the name of M. Leverrier, the distinguished Director of the Paris Observatory, does not appear on the commission; he did not think the observations of the Transit necessary to prove the accuracy of his values of the solar parallax. Happily, his voice was overruled. The course taken, as the *Times* remarks, suggests how desirable some similar procedure here would have been.

"There are very many points of the greatest interest," the *Times* continues, "raised by the contents of this large volume to which we should refer did space permit; from beginning to end it shows how a nation should set itself to work—how all the intellect of a nation can and must be utilised, when a great problem involving many kinds of special knowledge has to be attacked. It is often said that in France science

is crushed by a dead weight of officialism, and that in England it is free. However true this may be of teaching, there is ample evidence in this volume that, in one branch of research at least, the very opposite of this statement is much nearer the truth, and the painful discussions which some time ago occurred in our own columns and elsewhere, the 'Appeals to America,' the action of the Board of Visitors of the Greenwich Observatory, and the like, afford a strong argument—if, indeed, one were needed—that the growth of science necessitates that in all future national enterprises of the kind the example of the French and of all the other Governments should be followed. In this way only, in our opinion, can the national scientific honour be upheld, while the officials concerned in carrying out the work would be strengthened in their positions and shielded from a responsibility too great for individuals to bear."

#### NOTES

THE arrangements for securing observations of the Solar Eclipse of April 6 are progressing most satisfactorily, thanks to the energy of the Royal Society Committee and the varied knowledge that has been brought to bear upon the various points of attack. Lord Salisbury has brought the proposed action of the Royal Society before the Council of India, and such instructions have already been telegraphed to India as will probably result in this eclipse being observed with a wealth of observers and instrumental appliances beyond all precedent.

CAPTAIN NARES, who is to command the English Arctic Expedition, has arrived in London. Commander Markham returned on Saturday from Dundee, after having entered six good men, tried seal and whale fishers, as ice-quartermasters. Staff-Surgeon Thomas Colan, M.D., of the *Unicorn*, drill-ship of the Naval Reserve at Dundee, has been selected by the Admiralty as senior medical officer of the Expedition. With regard to the proposed German Expedition, the desire is, we believe, if the funds can be raised, to form a scheme of co-operation between the two exploring expeditions. Surely our brother Teutons, richer now than ever they were, and whose zeal for knowledge is proverbial, will not allow this splendid scheme to be marred for lack of funds.

THE Museum of the Royal College of Surgeons contains a series of casts of the interior of the cranial cavity, representing exactly the form and size of the brain (when covered by its membranes), of men of various races, and of many species of animals. With a view to diffuse the information to be derived from the study of these casts, and believing that many educational institutions will be glad to avail themselves of the opportunity of possessing them, the Council of the College has authorised the issue of copies at the lowest price at which they can be reproduced, which will partly depend upon the number likely to be required. The Conservator of the Museum would like those who desire to possess the whole or part of the series, which comprises many rare forms, to communicate with him on the subject.

AT its *séance* of Jan. 11, the Paris Academy elected a corresponding member in the section of Mechanics, in place of the late M. Burdin. Three candidates were proposed—M. Broch, the Norwegian mathematician, who obtained twenty-four votes; Prof. Stokes, F.R.S., twenty-one votes; and M. Calladon, one vote. Thus M. Broch was elected by only three votes over Prof. Stokes.

MR. SIMON NEWCOMB, the American astronomer, is now in Paris. He has paid a visit to the Observatory, in order to inquire into the possibility of constructing a large refracting telescope having a lens of one metre in diameter. A sum of

30,000*l.* was, as we have already intimated, placed at his command by Mr. Lick, the celebrated Californian capitalist, who is the founder of the Lick Observatory.

M. CHEVREUL, the great French chemist and director of the Jardin des Plantes, has been presented by the Minister of Public Instruction with the grade of Grand Officer in the Legion d'Honneur. This promotion is considered as being a compensation for the difficulties raised by the Ministry in the appointment of a Professor in the Museum. These quarrels had induced the venerable *savant* to resign.

The *Bulletin* of the French Geographical Society for December contains an exceedingly interesting and carefully compiled paper by M. H. Duveyrier, entitled "L'Afrique Necrologique." This is a list of all the African explorers, from 1800 to 1874, who have met their death while doing their work, either from disease caught in the country, or by murder, or other causes; a very large proportion have died from "intermittent fever." The list includes not only those whose object was purely geographical discovery, but also those whose researches were connected with geology, meteorology, botany, zoology, ethnography, archaeology, or languages. The list is a sadly long one, numbering about 150; and M. Duveyrier, in each case, gives a brief account of the explorer and of the work which he accomplished; a large proportion of these martyrs to science are English. Accompanying the paper is an ingeniously constructed map, showing the place at which each traveller met his death.

It is announced that the committee to whose hands the Sub-Wealden Exploration is entrusted has resolved to abandon the present boring after six ineffectual efforts to recover tools which have dropped down and obstructed the whole. The Diamond Boring Company having made a very favourable offer to commence again, a contract for the completion of 1,000 feet for 600*l.* has been agreed to, with a conditional promise to execute the second thousand feet for about 3,000*l.* additional. Mr. Willett, hon. sec., has guaranteed 600*l.*, and appeals for funds to carry on the enterprise.

MR. CHARLES DARWIN'S new work on "Insectivorous and Climbing Plants" is in the press and will be shortly published. The following are the contents:—Part I.: On the sensitiveness of the leaves of *Drosera*, *Dionaea*, *Pinguicula*, &c., to certain stimulants; and on their power of digesting and absorbing certain animal matter. Part II.: On the habits and movements of climbing plants. The book will be issued by Mr. John Murray.

MR. JOHN MURRAY has also preparing for publication the following two works in travel:—"The Land of the North Wind," being an account of travels among the Laplanders and Samoyedes, and along the coast of the White Sea, by Edward Rae; this book will be illustrated by a map and woodcuts: and a description of a journey to Tabreez, Kurdistan, down the Tigris and Euphrates to Nineveh and Babylon, and across the desert to Palmyra, by Baron Max von Thielmann. The title of the book will be "The Caucasus, Persia, and Turkey in Asia," and it will be translated from the German by Mr. Charles Henegau.

MESSRS. LONGMAN and Co. have in the press a translation of a work on the Primæval World of Switzerland, by Prof. Oswald Heer, of the University of Zurich. The book will be edited by Mr. James Heeywood, M.A., F.R.S., and will be issued in two octavo volumes with numerous illustrations. The same firm will shortly publish a series of Elementary Lessons on the Structure of Man and Animals, with special reference to the principles affecting health, food, and cooking, and the duties of man to the animal creation; by Mrs. Buckton. This volume will be illustrated with wood engravings.

In the *Astronomische Nachrichten*, Nos. 2,009 and 2,016, are notes on the spectroscopic observation of fifty-two stars made by M. D'Arrest. The stars are chiefly of the 6th and 7th magnitude, and appear in the Bonn Catalogue. The colours of thirty-four of these stars are given, and the type to which each star belongs is generally mentioned. From an analysis of the notes we gain that there are in the list four red or reddish stars of type III., and two of type IV.; of reddish yellow stars there are nine of type III.; of yellow or orange stars there are thirteen of type III., and of the same type one brown and five colourless ones; on the remaining eighteen there are no remarks on colour. The author remarks on the different grades of spectra of type III., from an almost line spectrum to a discontinuous one of bands, as that of a Hercules, but that grades of colour do not always agree with grades of spectrum; and he thinks that the theory that the coloured stars are older because cooler than others cannot be received without numerous exceptions, and he has concluded that the temperature of the coloured stars may in general be lower than that of others, but that it is not proved; and further, that the greater age of these stars is without foundation. The author appears to take exception to the part of the address of M. Wurtz at the French Association, reported in *NATURE*, vol. x. p. 350, where he says of the stars, "We have classed them according to their ages. Stars coloured, stars yellow, stars white; the white are the hottest and the youngest. . . the coloured stars are not so hot, and are older." It certainly seems from M. D'Arrest's observation that there are exceptions to this rule, and a large number of stars must have their spectra and colours tabulated before it can be judged how far this law holds good.

At the last meeting of the Photographic Society a paper was read by Mr. Hooper, "On the Origin, Aim, and Achievements of the Photographic Society, with suggestions as to its future development." The suggestions were, the necessity of obtaining a Royal Charter, the Society's claim upon the Government for a money grant and suitable premises, and the necessity of forming committees for scientific investigation. In the subsequent discussion, the general opinion was that there was little hope of obtaining the proposed Charter, and that it was a mistake to speak of photography as a science. "Science," one speaker said, "had done a great deal more for photography than photography had done for science."

At the meeting of Convocation of the London University on Tuesday, the motion brought forward by Mr. A. P. Hensman, "That, in the opinion of Convocation, it is desirable that women should be permitted to take degrees in Arts in this University," was, after some discussion, withdrawn.

A RECENT decision has been given by the French Ministry in favour of female doctors. A certain Mdlle. Domerque, of Montpellier, has received due authorisation to pass her examination for the doctorship.

WE are glad to see that by the decision of the Supreme Court at Sydney, N.S.W., Mr. Gerard Krefft has been restored to his position and house as Curator of the Sydney Museum. Mr. Krefft has been connected with the Museum for fourteen years, and in September last had been violently ejected by an order from the trustees, who, it seems, had in this exceeded their powers.

THE prospectus lies before us of a new Italian monthly journal, to be entitled, *Rivista Popolare di Scienze e Lettere*. Judging from the prospectus, its projectors have a high idea of the important place which science is daily assuming in the life of the world, and intend to devote a considerable proportion of the pages of their Review to subjects of scientific interest. The programme of the new journal is very comprehensive, embracing all departments of philosophy and physical science, and we most

heartily wish it complete success. The prospectus is dated from Lentini, in Sicily, where, we believe, the Review is to be published. It seems rather strange to make such an out-of-the-way place the head-quarters of so important an undertaking; we hope, however, its circulation won't suffer in consequence.

THERE are many signs that Italy is really awakened from her long dormancy and seems quietly determined to do her share of the modern world's work. The above announcement may be regarded as one, and we know that in more than one of the sciences valuable work is being done by Italians. In geography, especially, they seem inclined to revive the reputation which of old their country had; they have recently produced one or two noteworthy explorers, and their geographical magazine, *Cosmos*, is a model of typography and good editing. Only on Monday last, Prince Humbert, in returning thanks for his election as President of the Italian Geographical Society, spoke with warm approval of the project of an expedition to the African great lakes, and hoped that Italy would be worthily represented at the forthcoming Geographical Congress at Paris.

THE Queensland Government have received information that Hume, who proceeded in search of Classan, a supposed survivor of the Leichardt Exploring Expedition, perished for want of water fifty miles from Drynan's station on the Wilson River, in the Warrego district. O'Hea, another of the party, is also supposed to be dead. The third man, Thompson, has reached Drynan's station.

As about forty ladies and gentlemen have signified their intention to become members of the proposed Natural History Society at Watford, a meeting to found the Society and to elect a provisional committee will be held at the Watford Public Library on the 23rd inst., at seven o'clock.

P. W. WRIGHT, one of the late porters at the College of Surgeons Museum, commenced duty as dissecting-room porter at St. Thomas's Hospital about a fortnight ago. On last Tuesday week he wounded himself in the hand with a knife whilst assisting in a post-mortem on a child which had died of pyæmia. We regret to hear that he died in consequence of the wound, from the same disease, on Monday last, leaving a wife and five young children quite unprovided for.

M. J. DEBY, in examining the contents of the stomachs of mussels (*Mytilus edulis*) from the Brussels market, found thirty-seven species of diatoms, including *Hyalodiscus stelliger*, a species found previously only in Florida.

THE death of the veteran Dr. Gideon Linneceum, of Long Point, Texas (U.S.), is announced as having taken place at his residence on the 28th of November last, in his eighty-second year. Dr. Linneceum was well known to the naturalists of the United States on account of his abilities as an observer and the wonderful minuteness of his investigations into the habits and peculiarities of American animals. His contributions in this direction to the archives of the Smithsonian Institution, to the *American Naturalist*, to the Academy of Natural Sciences, and to the *American Sportsman*, were very numerous and varied. In addition to his contributions of notes, Dr. Linneceum was an extensive collector of specimens, especially of insects and reptiles of which he sent large numbers to the museums of the United States.

PROF. MARSH and his exploring party returned to New Haven, U.S., on Dec. 12, after an absence of two months in the Rocky Mountains. The object of the present expedition was to examine a remarkable fossil locality, discovered during the past summer in the "Bad Lands" south of the Black Hills. The explorations were very successful, notwithstanding extremely cold weather and the continued hostility of the Sioux Indians. The fossil deposits explored were, mainly of Miocene age,

and, although quite limited in extent, proved to be rich beyond expectation. Nearly two tons of fossil bones were collected, most of them rare specimens, and many unknown to science. Among the most interesting remains found were several species of gigantic *Brontotheriidae*, nearly as large as elephants. At one point these bones were heaped together in such numbers as to indicate that the animals lived in herds, and had been washed into this ancient lake by a freshet. Successful explorations were made, also, in the Pliocene strata of the same region. All the collections secured go to Yale College, and will soon be described by Prof. Marsh.

DR. HUNT gives an account, in the Proceedings of the Boston Society of Natural History, of the contents of the stomach of a mastodon lately found in Wayland, New York. These consisted of remains of both cryptogams and flowering plants, exhibiting distinctly the vegetable characters. No sphagnum was found in the deposit. The evidence was that the animal had eaten his last meal from the tender mosses and boughs of the flowering plants growing on the banks of streams and margins of swamps, and that pines and cedars formed no part of his diet.

CARRIER pigeons have been employed for a new purpose. When his Majesty of Spain was nearing Barcelona, a Spanish steamer was sent to meet *Los Navos* on the high seas, and succeeded in doing so at the distance of 150 miles from the seaport. Carrier pigeons were then liberated so as to announce in Barcelona the happy coming of Don Alphonso XII. The experiment appears to have been successful. It is said that carrier pigeons were in use among the old Roman navigators in the time of the Cæsars. The practice was discontinued for centuries, and the question has been asked by some French papers whether it is desirable to revive it for Transatlantic steamers.

THE Signal Service observer on the summit of Pike's Peak (U.S.) reports that the local storms there experienced originate over the parks to the westward on hot afternoons. On one occasion he was favoured with an excellent view of the interior structure of the clouds of a tornado, when he observed that while the cloud-bearing currents of air float toward the centre, they had a decided downward movement, but that masses of smoke-like vapour rapidly ascended through the interior funnel.

IN a paper read by Capt. Shaw, of the Metropolitan Fire Brigade, at the Society of Arts on Tuesday night, an ingenious apparatus was described for enabling persons to breathe in dense smoke or poisonous vapours. It consists essentially of a close-fitting hood, with a respirator, holding a filter, the invention of Prof. Tyndall, which consists of a valve chamber and filter tube about 4 inches long, screwed on outside, with access to it from the inside by a wooden mouth-piece. The charge for the filter consists of the following materials, which are put in with the tube turned upside down, and the lower valve removed:—Half an inch deep of dry cotton-wool, an inch deep of the same wool saturated with glycerine, a thin layer of dry wool, half an inch deep of fragments of charcoal, half an inch deep of dry wool, half an inch deep of fragments of lime, and about an inch of dry wool. The whole can be put on and adjusted in a few seconds by the wearer.

THE additions to the Zoological Society's Gardens during the past week include a Pig-tailed Monkey (*Macacus nemestrinus*) from Java, presented by Dr. Cole; a Crested Iporcupine (*Ilystrix cristata*) from Mogadore, presented by Mr. Alfred Hay; two Chukar Partridges (*Caccabis chukar*) from North-west India, presented by Capt. Murray; a Sooty Mangabey (*Cercopithecus fuliginosus*), and a Patas Monkey (*Cercopithecus ruber*) from West Africa; an Australian Goshawk (*Astur approximans*) from Australia, purchased; an Ocelot (*Felis pardalis*) from America, deposited.

## SCIENTIFIC SERIALS

*Poggendorff's Annalen der Physik und Chemie*, No. 10.—This number contains several papers of great interest: the first is by G. Quincke, on electric currents resulting from the non-simultaneous insertion of two mercury-electrodes into different liquids. The author bases his experiments upon those of St. Claire Deville and Troost, who found it probable that platinum absorbs hydrogen or other gases when being heated in a gas or alcohol flame, and then shows a different electric action towards water and dilute acids from that of platinum that has not been so heated. The paper contains a minute description of the apparatus used and tables of the results obtained; in an appendix the author treats of the relation between capillary and electrical phenomena, referring to G. Lippmann's paper (*Pogg. Ann.*, vol. 149, p. 556), from whom he materially differs.—Experiments made with a magnetised copper wire, by Prof. Balfour Stewart and Dr. A. Schuster.—On the chemical action of the solar spectrum upon haloid salts of silver, by H. W. Vogel. Chloride, bromide, and iodide of silver, are not only sensitive towards the highly refrangible rays of the spectrum, but also towards the less refrangible ones, although in a much smaller degree; their sensitiveness does not only depend upon their optical power of absorption of the respective rays, but also upon the absorption power of other substances they may be mixed with. Coloured substances which assist the photographic reduction process and absorb certain spectral rays, highly increase the sensitiveness of the silver salt towards the absorbed rays; thus the sensitiveness of silver salts for red, yellow, and green rays can be greatly augmented. Certain colourless bodies are found to have a similar action. The light reflected from pigments shows a very different effect from that of spectral colours, on account of the varying optical composition of artificial colours and their smaller intensity.—On the question of velocity of magnetic action at distances, by H. Herwig; investigations relating principally to terrestrial magnetism. It is found that this velocity is at least half a million geographical miles (or about 2½ millions of English miles) per second; in other words, that at any given spot on the surface of the earth terrestrial magnetism becomes fully active in less than the 300th part of a second.—On a modification of the magneto-electric revolution experiment, by the same.—On comparison of electric machines, by Mr. Mascart. The author describes experiments made to ascertain the actual quantity of electricity produced by eleven different machines in a given time and under the same conditions.—On the measuring of the electromotive power of voltaic piles in absolute units, by A. Crova.—The frequency of changes of colour in the scintillation of stars is generally related to the spectrum they show, by C. Montigny. Stars that twinkle strongly show few spectral lines, while those with little scintillation have many bands and lines in their spectra.—On the theory of organ-pipes, by H. Schneebeli.—Is the application of the *vis viva* justified in the mechanical theory of heat? by H. Fritsch. The author answers this question in the negative.—On induction-effects in magnets of different hardness, by L. Kulp.

## SOCIETIES AND ACADEMIES

## LONDON

Royal Society, Jan. 7.—“Remarks on a New Map of the Solar Spectrum,” by J. Norman Lockyer, F.R.S.

I beg permission to lay before the Royal Society a portion of the new map of the solar spectrum, referred to in one of my former communications.

It consists of the portion between  $\nu$ . 139 and 41.

I have found it necessary, in order to include all the lines visible in my photographs in such a manner that coincidences may be clearly shown, to construct it on four times the scale of Angström's “Spectre-Normal.”

The spectra of the following elements have been photographed side by side with the solar spectrum, and the coincidences shown:—

Fe, Co, Ni, Mn, Ce, U, Cr, Ba, Sr, Ca, K, Al.

The wave-lengths of new lines in the portion of this spectrum at present completed have been obtained from curves of graphical interpolation. Instead of the reading of a micrometer-scale, a photographic print of the spectrum has been employed in the construction of these curves, the wave-lengths of the principal lines being taken from an unpublished map of the ultra-violet region of the solar spectrum, a copy of which has been kindly placed at my disposal by M. Cornu. The photograph of the

solar spectrum, from the ultra-violet to beyond F, kindly given to me by Mr. Rutherford, has also proved of great service in the present work. I have, in fact, up to the present time, only been able to excel this photograph in the region about H.)

From the extreme difficulty of carrying on eye-observations upon the portion of the spectrum now completed, Angström's map is, of course, very incomplete about this region. The few lines mapped differ slightly in some cases from the positions assigned by Cornu; but the wave-lengths given by the latter observer generally fall into the curve without breaking its symmetry, and these positions have therefore been adopted. The advantage possessed by the photographic method over eye-observation may be estimated from the following numerical comparisons:—

Region of spectrum, 3900–4100.	
Number of lines in Angström's “Spectre-Normal”	39
“ “ Angström's and Thalén's map of the violet part of the solar spectrum	185
“ “ Cornu's map	205
“ “ New Map	518

It will serve further to illustrate the advantages of the photographic method, to compare the number of lines in the spectra of metals already observed with the number of lines of the same metal given by Angström in the “Spectre-Normal.”

## Region of spectrum, 3900–4100.

Metal.	Lines in new map.	Lines in Thalén's map.
Fe	71	19
Mn	53	12
Co	47	—
Ni	17	—
Ce	163	—
U	18	—
Cr	24	—
Ba	7	—
Sr	5	—
Ca	7	6
K	2	—
Al	2	2
Total	416	39

The purification of the various metallic spectra has at present been only partially effected; but I have seen enough already to convince me of the extreme rigour with which the principle I have already announced may be applied, while at the same time there are evidences that the application of it may lead to some results not anticipated in the first instance.

My object in laying these maps before the Society, and presenting this *ad interim* report of progress, is to appeal to some other man of science, if not in England, then in some other country, to come forward to aid in the work, which it is improbable that I, with my small observational means and limited time, can carry to a termination. I reckon that, having regard to routine solar work, it will require another year before the portion from H to G is completely finished, even for the metals the spectra of which are shown in the maps now exhibited. When this is done there will still remain outstanding all the ultra-violet portion, the portion from G to F, both capable of being photographed by short exposure, and the whole of the less refrangible part, which Draper and Rutherford have both shown can be reached by long exposure with the present processes.

I cannot but think, moreover, that when the light which the spectroscopes has already thrown upon molecular action shall be better known, and used as a basis for further inquiry, methods of photography greatly exceeding the present one in rapidity, in the less refrangible portion of the spectrum, will be developed and utilised in the research.

The map is being drawn by my assistant, Mr. Raphaël Meldola (to whom my thanks are due for the skill and patience he has brought to bear upon the work), in the first instance with more especial reference to the positions, thicknesses, and individualities of the lines; the final revision will consist of an absolute intensity reproduction of the photographs.

“On the Spectrum of Coggia's Comet,” by William Huggins, D.C.L., LL.D., F.R.S.

From his observations of five small comets in the years 1866, 1865, and 1871, the author had shown that a great part of the light of those comets was emitted by the cometary matter; and further, that carbon, in some form, was probably present in them.



Coggia's Comet presented in the spectroscope three distinct spectra:—

1. A continuous spectrum from the light of the nucleus.
2. A spectrum of bright bands.
3. A continuous spectrum accompanying the gaseous spectrum on the coma, and representing almost entirely the light of the tail.

The author then gives his observations of three different spectra, and of the relative intensity of the two latter spectra in different parts of the comet.

On acoustic reversibility, by J. Tyndall, D.C.L., LL.D., F.R.S. In this paper Prof. Tyndall refers to the series of experiments on the velocity of sound which were made on the 21st and 22nd of June, 1822, between Villejuif and Monthéry, south of Paris, and 11·6 miles distant from each other.

On this occasion it was noticed that while every report of the cannon fired at Monthéry was heard with the greatest distinctness at Villejuif, by far the greater number of the reports from Villejuif failed to reach Monthéry. The air at the time was calm, the slight motion of translation actually existing being from Villejuif towards Monthéry, or against the direction in which the sound was best heard.

So far as the author knows, no explanation of this has hitherto been given.

Experimenting with a sensitive flame, from 18 to 24 inches in height, and a reed, less than a square quarter of an inch in area, on a screen of cardboard, 18 inches high by 12 inches wide, in all cases it was shown that the sound was effective when the reed was at a distance from the screen and the flame close behind it; while the action was insensible when these positions were reversed.

It was observed and recorded when the experiments of 1822 were made, that while the reports of the guns at Villejuif were without echoes, a roll of echoes, lasting from twenty to twenty-five seconds, accompanied every shot at Monthéry, being heard by the observers there.

From various considerations the author infers that Monthéry, on the occasion referred to, must have been surrounded by a highly diacoustic atmosphere; while the shortness of the echoes at Villejuif shows the atmosphere surrounding that station to have been acoustically opaque.

The non-homogeneous air surrounding Villejuif is experimentally typified by the screen with the source of sound close behind it; the upper end of the screen representing the place where equilibrium of temperature was established in the atmosphere above the station. In virtue of its proximity to the screen, the echoes from the sounding-reed would, in the case here supposed, so blend with the direct sound as to be practically indistinguishable from it, as the echoes at Villejuif followed the direct sound so hotly, and vanished so rapidly, that they escaped observation. And as the sensitive flame, at a distance, failed to be effected by the sounding-body placed close behind the cardboard screen, so, the author takes it, did the observers at Monthéry fail to hear the sounds of the Villejuif gun.

Something further may be done towards the experimental elucidation of this subject. The facility with which sounds pass through textile fabrics has been already illustrated; \* a layer of cambric, or even of thick flannel or baize, being found competent to intercept but a fraction of the sound from a vibrating reed. Such a layer of cambric may be taken to represent a layer of air differentiated from its neighbours by temperature or moisture; while a succession of such sheets of cambric may be taken to represent successive layers of non-homogeneous air.

Two tin tubes with open ends were placed so as to form an acute angle with each other. At the end of one is the vibrating reed; opposite the end of the other, and in the prolongation of its axis, is a sensitive flame—a second sensitive flame being placed in the continuation of the axis of the first tube. On sounding the reed, the direct sound through the first tube agitates the second flame. Introducing the square of cambric at the proper angle, a slight decrease of the action on the second is noticed, and the feeble echo from the cambric produces a barely perceptible agitation of the first flame. Adding another square, the sound transmitted by the first square impinges on the second. It is partially echoed, returns through the first square, passes along the second tube, and still further agitates the flame opposite its end. Adding a third square, the reflected sound is still further augmented, every accession to the echo being accom-

panied by a corresponding withdrawal of the vibrations from the flame opposite the first tube, and a consequent stilling of that flame.

With thinner cambric it would require a greater number of layers to intercept the entire sound. Hence, with such cambric, we should have echoes returned from a greater distance, and, therefore, of greater duration.

Jan. 14.—“On a Class of Identical Relations in the Theory of Elliptic Functions,” by J. W. L. Glaisher, M.A., Fellow of Trinity College, Cambridge; communicated by James Glaisher, F.R.S.

Chemical Society, Jan. 14.—Prof. Odling, F.R.S., president, in the chair.—On the action of the organic acids and their anhydrides on the natural alkaloids, Part III., by Mr. G. H. Beckett and Dr. C. R. A. Wright, was read by the latter. It is a continuation of their researches on the opium alkaloids morphine and codeine.—The next communication was a note on the effect of passing the mixed vapours of carbon bisulphide and alcohol over red-hot copper, by Mr. T. Carnely.—Dr. H. E. Armstrong then read a paper on the iodonitrophenols.

Anthropological Institute, Jan. 12.—Prof. Busk, F.R.S., president, in the chair.—Mr. T. J. Hutchinson, F.R.G.S., late H.M.'s Consul, Callao, read a paper on the anthropology of Prehistoric Peru. The paper commenced with a notice of how little is known up to the present time about the glorious days of Peru long before the time of the Incas, agreeing with Mr. Baldwin as to the original South Americans being the oldest people on that continent. The grandeur of colossal works in the extent of the ancient burial mounds was shown by illustrations. A comparison of these examined by the author in Peru was made with those explored by Messrs. Squier and Davis in the valleys of the Ohio and the Mississippi. The prehistoric architecture of Peru, described by Prof. Raimondi in his recent work on the mineral riches of the department of Aucachs, were mentioned as highly interesting; more particularly the tombs cut out of solid blocks of diorite in the valleys where sandstone is the geological character; thus proving the enormous capacity for work of the ancient Peruvians in transporting these stony masses over the Andes. So small was the author's faith in Spanish accounts of South America, that he inclined to the belief in some future explorer finding the mythical “cradle of the Incas” in the National Library at Madrid, instead of in the Lake of Titicaca, to which latter place it is accredited by the Hakluyt Society.—A paper, by Dr. George Dobson, was read on the Andamans and Andamanese. After giving a sketch of the geographical position of the Andaman Islands and their geological and zoological relations to the Asiatic continent, the author passed in review the various theories that had been propounded by eminent biologists to account for the origin of the Andamanese. He strongly inclined to the views of Mr. Wallace and M. Quatrefages that the Andamanese are Nigritos, or Samangs from the Malay peninsula, and was opposed to the theory of their descent from shipwrecked African negroes, on the ground rather of the dissimilarity of their manners and customs than of their physical characteristics. It was impossible, however, to account for the presence of the wild tribes of Southern India or of the peculiar Samangs of the interior of the Malay peninsula, surrounded by races with which they have no connection whatever, except on the hypothesis that they are the few surviving descendants of a woolly-haired people which in ages past occupied lands south of the Himalayas when the continent of Asia included within its southern limits the Andamans, Nicobars, Sumatra, Java, Borneo, and the Philippine Islands; and that the present inhabitants of the Andamans and the Nigritos of the Philippines are also the remnant of those ancient Nigrito inhabitants of Southern Asia, which have almost disappeared before the invading Aryan and Mongolian races. Dr. Dobson exhibited a series of photographs, taken by himself, of Andamanese men and women.

Entomological Society, Jan. 4.—Sir Sidney Smith Saunders, C.M.G., president, in the chair.—Mr. Stevens exhibited varieties of *Diloba carulocephala* and *Hibernia defoliaria*, bred from larvae taken near Brighton.—Mr. Smith exhibited a box of hymenopterous insects collected in the neighbourhood of Calcutta by Mr. Rothney. It comprised several rare species of *Formicidae* and *Fossorids*, and also many undescribed species of *Apidae*, amongst which were two species of *Nonia*, one of them with remarkable capitate antennae.—Mr. M'Lachlan made some remarks on the December Moth (*Cheimatobia brunata*), which he had observed one evening during the recent severe frost.

\* Phil. Trans., Feb. 1874.

attracted in great numbers to the gas lamps in the neighbourhood of Lewisham. Mr. Weir remarked on the importance of ascertaining whether they were hibernated specimens or whether they had been newly hatched during the severe weather.—A letter was read from Mr. R. S. Morrison, of George Town, Colorado, expressing a wish to be placed in communication with any entomologists who might be interested in the insect faunas of the higher altitudes (8,000 to 14,000 ft.), which he considered should be more fully investigated.—The Secretary exhibited a small bottle containing specimens of a *Mantis*, forwarded to him from Sarawak by Mr. de Crespigny. He stated that while sitting at table his notice was attracted by the unusual appearance of a column of ants crossing it; but on looking more narrowly he observed that they were not ants, but a species of *Mantis*, and he believed them to be full-grown insects, but that they had no wings. Mr. M'Lachlan, however, observed that some of the specimens had rudimentary wings; and the President and others expressed a belief that they would prove to be larvae, and not perfect insects.

Institution of Civil Engineers, Jan. 12.—Mr. Thos. E. Harrison, president, in the chair.—The paper read was on the construction of gasworks, by Mr. Harry E. Jones.

## BERLIN

German Chemical Society, Dec. 19.—Annual ordinary meeting; A. W. Hofmann, V.P., in the chair.—The vice-president reported on the state of the Society, which counts 1,209 members, while the reports are published to the number of 1,800 copies. The number of papers published through its means amounted to more than 500 during the last year. The elections called the resident officers back to their posts, while, as non-resident members of the committee, the following were elected for the new year:—Messrs. Baeyer, Griess, Ladenburg, Landolt, and Schorlemmer.

Dec. 28.—A. W. Hofmann, V.P., in the chair.—P. Wallach and A. Böhringer, in treating methylated oxamine with  $\text{PCl}_5$ , have produced a well-defined base yielding well-crystallised monobasic salts and a direct combination with  $\text{C}_6\text{H}_5\text{I}$ . The base  $\text{C}_6\text{H}_4\text{ClN}_2$  has received the name chlorox methylamine, and is homologous with  $\text{C}_6\text{H}_5\text{ClN}_2$  lately produced by Dr. Wallach from ethylated oxamine in a similar way.—I. Piccard has succeeded in producing anthracinone by heating, in closed tubes to  $220^\circ$ , benzol and phthalic chloride with zinc:



I. Siebel proposed as a method for producing soda the treatment of tribasic phosphate of soda with carbonic acid, adding subsequently carbonate of ammonia. The double phosphate of sodium and ammonium crystallises out, while two-thirds of the sodium, transformed into carbonate, remain in solution.—A. Oppenheim reported on a mechanical method for preventing the most frequent cause of the incrustation or furring of steam boilers, lately patented by a large boiler-maker, M. Paukoch, in Landsberg. Instead of introducing the water directly into the boiler, he lets it run slowly through a wide tube passing through the boiler. Here, on being heated, the water deposits its carbonate of lime before it is admitted into the boiler. As the inner tube is not in contact with the fire, the deposit in it cannot produce the usual dangerous results.

## PARIS

Academy of Sciences, Jan. 11.—M. M. Fremy in the chair.—The following papers were read:—On the mesocephalic and brachycephalic fossil human races, by M. de Quatrefages, being the third part of the author's and M. Hamy's work on the skulls of the human races.—Report on M. Alph. Guérin's work, on the patho-genetic effect of fermentation products in surgical cases, and a new method of treatment of the amputated, by M. Gosselin.—MM. Bouilland and Pasteur then spoke in detail on the same subject; M. A. Trécul made some observations with regard to the production of vibriones and bacteria, in reference to the last subject.—Report on M. Halphen's memoir, concerning the important points of plane algebraic curves, by M. de la Gournerie.—On the existence of the integral in equations with partial derivatives, containing any number of functions and independent variables, by M. G. Darboux.—On the action of electrolytic oxygen on alcohol, by M. A. Renard; experiments made by the author, who exposed alcohol, to which about five per cent. of dilute sulphuric acid had been added, to an electric current from

four to five Bunsen cells, and analysed the products after forty-eight hours' action: he found ethylic formiate and acetate, aldehyde, acetal, ethyl-sulphuric acid, and a new substance, ethylenic-monoethylate, which may be regarded as an acetal  $\text{C}_2\text{H}_5\text{O} \begin{array}{c} \text{C}_2\text{H}_5 \\ \text{HO} \end{array}$ , in which one  $\text{C}_2\text{H}_5$  is replaced by H, thus possessing the formula  $\text{C}_2\text{H}_5\text{O} \begin{array}{c} \text{C}_2\text{H}_4 \\ \text{HO} \end{array}$ .—On the "seiches" of Lake Lemman, by F. A. Forel. *Seiches* are the sudden rises and falls in the level of this lake. The author gives an explanation of these phenomena and considers them constant and frequent in all larger lakes, and not rare and accidental as was believed hitherto.—A note by M. Martha-Becker, relating to his paper on ether and the origin of matter.—A note by M. H. de Kerikuff, with corrections for his communication on the velocity of light and the parallax of the sun.—A note by M. Poupelle, with regard to a system of electric danger signals to prevent railway collisions on a single line of rails.—On the reduction of equations with partial derivatives to ordinary differential equations, by M. W. de Maximovitch.—M. E. Flaqueur communicates the observations and calculations made by the French Commission for the measuring of the arc of meridian between Barcelona and the Balearic Isles.—M. Lemonnier gives some new theories with regard to equations with common roots.—On the correction of Descartes' ovals, by M. A. Genocchi.—On some properties of the curvature of the surfaces, by M. Halphen.—On stratified light, by M. Neyreneuf.—On the specific rotative power of mannite, by M. G. Bouchardat; accounts of experiments made in M. Berthelot's laboratory.—M. P. Bouloumie communicates the results of his observations and researches on micro-organisms in suppurations, their influence on the healing of wounds, and the different means to prevent their development.—On white globules in the blood-vessels of the spleen, by MM. Tarchanoff and A. Swaen.—On the habits of a remarkable serpent of Cochinchina: *Herpeton tentaculatum*, by M. A. Morice.

## BOOKS AND PAMPHLETS RECEIVED

BRITISH.—On the Recent Progress and Present State of Systematic Botany: George Bentham, F.R.S. (British Association).—Institution of Civil Engineers (Printed by Private Press).—Agricultural Gazette Almanack, 1875 (W. Richards).—Westminster Review, January 1875 (Trübner).—The Nagpur Waterworks: James Forrest (Clowes and Sons).

FOREIGN.—Note sur un procédé pour donner ou pour rendre leur couleur rouge aux muscles Conservés dans l'alcool: Félix Plateau (F. Hayez, Bruxelles).—Un parasite de l'Pheiroptères de Belgique: Félix Plateau (Académie Royale de Belgique).—Die Lösung der wichtigsten probleme in der Natur: Johann Friedrich Lechner (E. H. Mayer, Leipzig).—Les Comètes: Amédée Guillemin (Paris, Hachette and Co.).—In Sachsen Darwins insbesonder Contra Wigan: Dr. Gustav Jaeger (Stuttgart, E. Schweizerbart).—Annuaire de l'Académie Royale des Sciences, des Lettres, et des beaux-Arts de Belgique, 1875 (Brussels, F. Hayez).—Third Annual Report of the Director of the Imperial Mint, Osaka, Japan. Year ending July 31, 1874 (*Higo News Office*).—Der Darwinismus und der Naturforschung Newtons und Cuviere: Dr. Albert Wigan (Brunswick, F. Vieweg und Sohn).

## CONTENTS

PAGE

DR. LLOYD'S "TREATISE ON MAGNETISM." By Prof. BALFOUR	
STEWART, F.R.S. . . . .	221
SIMON'S "SPIDERS OF FRANCE" . . . . .	221
ANTHROPOLOGICAL NOTES AND QUERIES. . . . .	226
OUR BOOK SHELF:—	
Oliver's "Elementary Botany" . . . . .	226
LETTERS TO THE EDITOR:—	
On the Northern Range of the Fallow Deer in Europe.—By Prof. BOYD DAWKINS, F.R.S. . . . .	226
The Habits of the Belted Kingfisher ( <i>Ceryle alcyon</i> ).—CHAS. C. ABBOT . . . . .	227
KIRK'S PHYSIOLOGY.—W. PERCY ASHE . . . . .	227
Phœnician Characters in Sumatra.—J. PARK HARRISON . . . . .	228
King Blackbird.—DR. C. M. INGLEBY . . . . .	228
OUR ASTRONOMICAL COLUMN:—	
Eclipse of the Sun on April 6 . . . . .	228
Finck's Comet . . . . .	228
Winnecke's Comet . . . . .	228
Borrelly's Comet . . . . .	229
ON A PROBABLE CAUSE OF THE CHANGE OF THE COURSE OF THE AMU DARYA FROM THE CASPIAN TO THE ARAL. By Major HERBERT WOOD ( <i>With Illustration</i> ). . . . .	229
THE PARIS INTERNATIONAL CONGRESS OF GEOGRAPHICAL SCIENCE . . . . .	232
ON THE ALTRERATION OF THE NOTE OF RAILWAY WHISTLES IN TRAINS MEETING EACH OTHER. By Dr. W. FOLE, F.R.S. . . . .	232
GLASGOW SCIENCE LECTURES. By JOHN MAXER . . . . .	233
ATLANTIC NOTES. By Capt. Wm. W. KIDDLE . . . . .	234
THE TRANSIT OF VENUS . . . . .	234
NOTES . . . . .	235
SCIENTIFIC SERIALS . . . . .	238
SOCIETIES AND ACADEMIES . . . . .	240
BOOKS AND PAMPHLETS RECEIVED . . . . .	240

THURSDAY, JANUARY 28, 1875

THE MARQUIS OF SALISBURY ON  
SCIENTIFIC EDUCATION

THE scientific world is much indebted to the Marquis of Salisbury for the clear and powerful speech on the value of scientific education which he delivered in Manchester on Friday last. It is a satisfactory sign of the times when a statesman of his position and intellectual standing acknowledges the claims of science to a place in the higher education of the country equal to that of the older studies. Whilst adverting to the great strides which had been made respecting the elementary education of the country, Lord Salisbury does not forget that "the true key to the education of the lower classes is a love of knowledge on the part of the classes that are above them;" and he goes on to point out that in the district in which he was speaking, the secondary, and especially adult education, was well provided for. He passed a well-deserved encomium on the Owens College. Although the general instruction of the adult population by means of evening classes does not form the primary work of a College such as Owens, yet, placed as it is in the midst of a dense and busy population, it has found that there is much good work to be done in this direction.

In this service there can be no rivalry between Owens College and other institutions of a similar character; each has its own sphere, and, indeed, the truth is that if in large cities evening classes are to be of essential service, they must not be confined to one institution. For not only must the focus of instruction be near the men who are wearied with a hard day's work, but a different style of tuition naturally grows up in the various centres; one may, by natural selection, adopt one branch, and another another. Such a course is indeed the healthy development of a living organism which suits its growth to the conditions of its environment; and whilst it strengthens itself by so doing, it affords at the same time grateful sustenance and solace to those dwelling under its shadow. One of the great problems of the age, upon the successful solution of which much of our social and material prosperity depends, is indicated by the Marquis when he tells us that the truths of science should permeate the whole mass of the people. Evening classes such as we have referred to form one of the modes by which this may be accomplished. Another means of awakening the scientific interest of the people is by a widespread series of thoroughly trustworthy popular science lectures. Manchester has for some years taken a prominent position in this latter respect, and has been followed in this direction by the Gilchrist Trustees, who have established similar courses in the metropolis; whilst Liverpool, Glasgow, and other towns have recently determined to follow the same lead. The main object of such lectures is to interest more than to instruct, and we require, besides them, the general establishment of regular classes in which the subjects are thoroughly taught. Such classes are indeed established throughout the length and breadth of the country, thanks to the operations of the South Kensington Staff; and it is difficult to over-estimate the value of the scientific haul which year by year this

network thrown from the metropolis gathers up. From the satisfactory and rapid growth of this system of science teaching, the time must necessarily arrive when the central agency should not be confined to the metropolis alone, but should be supplemented by local centres, each of which would probably be more conversant with the special wants of its district than the metropolitan institution could possibly be.

Good as all such evening and adult science instruction may be, its prosperity must depend on the existence and healthy growth of a higher class of teaching, such as that afforded by the various universities and colleges throughout the country. It is their problem to teach the teachers, and it is in the carrying out of this great task that Governmental assistance is imperatively required. By this assistance, however, we do not mean that institutions are to be at once artificially created; such a thing is just as impossible as to bring a full-grown man into the world at once, without his passing through all the stages of childhood. Each higher school will naturally select, if properly fostered, its own special direction of development, and it is absurd to suggest any operation by which such a natural growth should be cut down, like a Dutch garden, in order to improve its form.

We have left untouched the question of the endowment of research; but it is obvious that to endow the unremunerative manufacture of knowledge is more important than to endow teaching which is always more or less remunerative.

## SOUTH AMERICAN TRAVEL

*Travels in South America, from the Pacific Ocean to the Atlantic Ocean.* By Paul Marcoy. Illustrated by 525 engravings and ten maps. Two vols. (London: Blackie and Son, 1875.)

*The Amazon and Madeira Rivers: Sketches and Descriptions from the Note-book of an Explorer.* By Franz Keller, Engineer. With sixty-eight illustrations on wood. (London: Chapman and Hall, 1874.)

*Two Years in Peru, with Exploration of its Antiquities.* By T. J. Hutchinson, M.A.I. With map and numerous illustrations. Two vols. (London: Sampson Low, 1873.)

WE notice these three works together, because to a considerable extent the first-mentioned embraces the ground gone over by the other two. Like Mr. Hutchinson, M. Marcoy devotes considerable space to the prehistoric antiquities and native populations of Peru, and, like Mr. Keller, the French traveller has much to say on the hydrography of the Amazon, on its fauna and flora, and on some of the numerous tribes that people the region contained within its vast basin. Of the three writers, M. Marcoy alone can be called a professional traveller,—at least, he appears as such in the present narrative; while Messrs. Keller and Hutchinson only took advantage of their vocation calling them to South America, to investigate what interested them in the particular regions which they visited. It is very gratifying to find men who do not profess to devote their lives to the advancement of scientific knowledge, so willing and competent as this engineer and this consul are to add to its sum. The number of such unprofessional—if we may so call them—advancers of scientific knowledge has in recent

years been gradually increasing; and we hope that with improved systems of education, both in Europe and in America, systems in which a training in science will have a prominent place, such scientific volunteers will become more and more numerous. Considering the large number of Englishmen alone who occupy positions in our own colonies and other foreign countries, in the midst of districts of which we have very little accurate knowledge, what a rich harvest might be expected if only one half of them had the scientific training to be obtained at a German *Realschule*!

The dates of publication of the three works at the head of this article are somewhat misleading; the order in time of the respective travels is indicated by the sequence of the titles.

M. Marcoy's narrative is in some respects a puzzling one. It may be said, so far as his own journey is concerned, that there is not a single date in the whole book. Whether this be the author's fault, or that of the publishers of this translation of his work, we do not know; but we deem it rather a serious one if the work is put forth as the genuine narrative of a traveller who wishes to be regarded as a trustworthy observer and recorder of phenomena, many of which may alter in the course of a very few years. M. Marcoy's observations as to the condition of the prehistoric remains of Peru, of the condition of the peoples, both dominant and native, with whom he came in contact, of the state of rivers, of the fauna and even of the flora, will be deprived of no small amount of their value

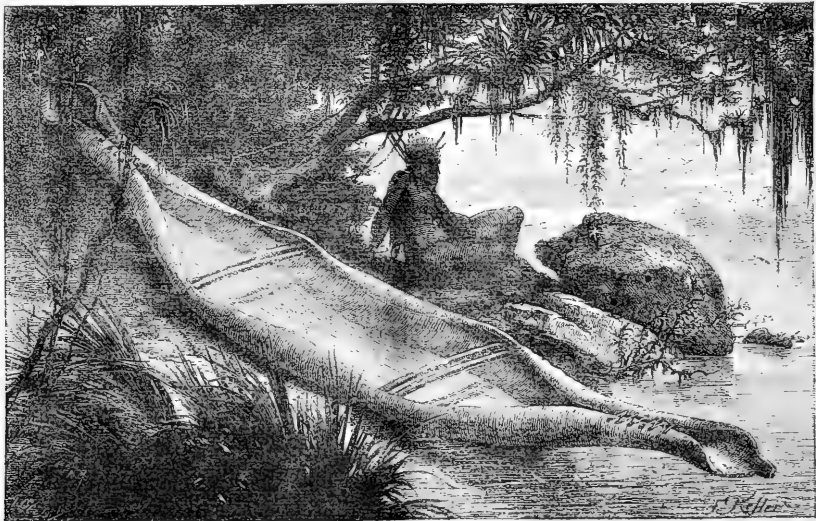

FIG. 1.—Bark Canoe of Wild Indians (Ardras and Caripunás).—Keller.

there is any doubt as to the date at which they were made. From internal evidence we conclude that the journey from Islay to Para was made during the twelve months following July either of 1847 or 1848; and we learn from St. Martin's recently published "History of Geography" that M. Marcoy was in the country about that time. But the work is thoroughly French from beginning to end, from the theatrical *pose* and costume of the author's portrait in the frontispiece to the final "Vale." We certainly believe that M. Marcoy made the journey across the South American continent about the year 1848, and that the work before us contains a narrative of what he heard and saw; but the author evidently studies effect so much, both in his illustrations and his style of writing, that one is apt to have a feeling that not unfrequently strict accuracy has been sacrificed, and that the author has given way to the very French failing of a love of exaggeration.

This, we think, is particularly seen in the author's account of the French scientific expedition, in the company of which he performed part of his journey. His portrait of the "Count de la Blanche-Epine," as he calls the leader of the expedition, is evidently a caricature, and we fear the same may be said of several other portraits in the book; and whenever he refers to the Count—and he does so *ad nauseam*—it is invariably with so much bitterness, that one is apt to think the Count had snubbed the somewhat Bohemian but evidently sensitive traveller.

But that the narrative has been revised within the last few years, is evident from several passages. He refers to occurrences which took place in 1866; and while sailing down the Amazon he discusses the value of observations which must have been made years after his journey. Throughout the work the personal narrative is frequently so mixed up with information obtained by the author either at other times—for he was many years in South America—or at

second hand, that it is often difficult to know where to draw the line; and thus one who is simply in search of a trustworthy narrative of observed facts is apt sometimes to feel insecure.

Moreover, we find from M. St. Martin's work, that "Marcoy" is really a pseudonym, the author's real name being Saint-Cricq. Why a veracious traveller should write under a pseudonym it is difficult to see; fancy Wallace, or Bates, or Livingstone, or Baker, or Payer, or Meyer doing so. Did "Paul Marcoy" fear the vengeance of the "Count de la Blanche-Epine?" That M. Marcoy intends his narrative to be taken *au sérieux* is evident throughout, from his elaborate and really valuable dissertations on the antiquities and original populations of

Peru, their sources and migrations, followed up by similar dissertations on the various groups of tribes he passed through, his minute and careful geographical descriptions, especially in connection with the Amazonian river-system, and the many details he gives concerning the fauna and flora of the extensive region which he traversed. We hope the publishers in the next edition will at least, if they can, give the exact date of M. Marcoy's journey; let them be assured that, instead of detracting from, it will add to the value of the work, even though with regard to Peru and the Amazon there have been later explorers.

Notwithstanding these blemishes, the work must be regarded as, on the whole, a trustworthy narrative, containing a great deal of valuable information, especially on



FIG. 2.—Submerged Forest.—Keller.

the tribes with which the traveller came in contact on the river Ucayali and its tributaries, and on the natural history of the regions he travelled through.

M. Marcoy's point of departure was the port of Islay, nearly under the 17th degree of south latitude. He tells us that his journey was undertaken as the result of a wager with the captain of an English vessel, that he would reach Para, in Brazil, by crossing the continent, as soon as the captain would sail to the same place round Cape Horn. As might be expected, he lost his wager. Still, considering, or because of, his simple equipment, and taking into consideration the frequent long stays he made at various places on his route,

his journey, performed in a year and fourteen days, must be regarded as a wonderful feat. At the same time he managed to see a great deal that is worth recording. He went by Arequipa, the north end of Lake Titicaca, Acopia, Cuzco, to Echarati, on the Rio Quillabamba Sta. Ana, as he calls the river marked Urubamba in most maps, even in that of Barrera (1871) prefixed to Mr. Hutchinson's work. M. Marcoy is extremely particular about the courses and names of his rivers, and, as we have said frequently enters into long dissertations on the subject, giving minute details with much confidence. He is particularly confident as to the courses and names of the numerous rivers that unite to form the Ucayali. Near

Echarati, he embarked in a canoe on the Quillabamba or Urubamba, and sailing down this river and its continuation, the Ucayali, reached Nauta, opposite the mouth of the latter, on the Amazon; getting a boat at Nauta, Marcoy sailed down the Amazon to Barra, at the mouth of the Rio Negro, completing his journey from that point to Para in a sloop.

The first part of his journey after leaving Islay is dreary enough, over desert pampas and barren mountain regions, and the weary iteration of the trivial incidents in each day's journey becomes in the end positively tedious. In connection with Cuzco, the author gives considerable details concerning Peruvian antiquities, some of the remains of which he appears to have carefully and minutely studied, and of which he gives some valuable illustrations—sculpture, statuary, fortifications, pottery; and lastly, what professes to be a series of the thirteen Incas and their wives from Manco Capac downwards, who reigned over Peru from the foundation of Cuzco to the Spanish Conquest. They are beautifully executed, but we fear their historical value won't count for much. M. Marcoy has a very complete theory as to the peopling of America by the ancestors of the native races who at present inhabit America. He recognises two different types as including nearly all the peoples both of North and South America—the Mongolo-American type and the Irano-Aryan type, of which the former, the colonising or swarming element, as he calls it, is by far the more numerous. Both races, he seems to believe, entered America from Asia at a very remote period, probably by Behring Strait, which at the time of the migration he appears to think was bridged over by an isthmus. He endeavours to connect the Irano-Aryan type at least with the ancient civilisation of India and Egypt, with modifications and additions acquired by the migrants from the various peoples with whom they came into contact in their progress north-eastwards through Asia. The Quichuas, Aymaras, Antis, and Chontaquiros, tribes of Peru, he connects with this civilising element, as he calls it, to which he apparently attributes most of the wonderful monuments that now remain. That there are two distinct types among the native inhabitants of Peru the latest and most trustworthy researches seem to prove, as also that there has been more than one immigration from Asia, but that right across the Pacific, and not by Behring Strait; but that the Incas were the authors of the wonderful works of which so many remains still exist, seems in the highest degree doubtful. We fear the theories of M. Marcoy on this point will be considered rather wild by the scientific investigator, who we daresay will prefer the sober hypotheses of Mr. Hutchinson, based as they are on a broad basis of facts. But more of this when we come to the work of the latter.

M. Marcoy gives many interesting details concerning the social life of the various cities and towns of Peru through which he passed on his way to Echarati. The picture presented is on the whole a sad one, and we should hope that since he made his journey there has been a great reformation, and that since railways and steamers have brought the people more into contact with the busy world of Europe and North America, industry, morality, and education have attained a higher platform.

The real interest of M. Marcoy's journey begins when

he launches on the river Quillabamba, probably the most tortuous river in the world, and so studded with rapids that navigation, except in canoes, is utterly impracticable. M. Marcoy gives much scattered information, helped considerably by the artistic illustrations, of the vegetation on the banks of this and the other rivers down which he passed. The traveller was nothing if not an artist; and the work before us, in the eyes of most readers, will derive half its value from the beautifully executed and graphic illustrations, which enable one to realise the scenes through which the author passed, better than any amount of description. So his sketches of the native Indians give one a good idea of the different types met with along his route. Most of these, we should think, are portraits, and, some allowance, no doubt, must be made for the author's tendency to artistic exaggeration. Some of these portraits, as well as some of the sketches illustrating the social life and habits of the natives, we recognise as having been used (without acknowledgment) in a recent popular work on anthropology. This suggests the idea that the publication, so far as scientific purposes are concerned, is rather late; we should think it likely that whatever the work contains of value bearing on the ethnology, geography, and natural history of the Amazonian region, has already found its place in those sciences through the French edition.

Although the author enumerates many tribes to be met with on the Ucayali and its tributary rivers, the members of these tribes at the time he visited were very few, and the region through which he passed on his way to the Amazon appeared to be but thinly inhabited, notwithstanding the abundance of food, both vegetable and animal. Indeed, the native races of South America, like those of North America, seem to be dying out before the advance of the white man, though not so rapidly, for the simple reason that the spread of the white man over the southern continent is much more slow, and the whites themselves seem to be nearly as lazy as the Indians. Perhaps the fostering care of the Jesuit missionaries may also have helped somewhat in preventing the rapid extinction of the Indian tribes. These missionaries have been at work more or less ever since the Spanish conquest of Peru, and the "converts" may be counted by thousands, though M. Marcoy thinks, and he is not singular in the opinion, that the missionaries have succeeded only in producing a degraded type of Indian, differing from his heathen brother simply in having lost his independent spirit. M. Marcoy appears to be thoroughly acquainted with the history of the Jesuit missions in Peru, and one of the most pleasant episodes in his work is the account of his long stay at a mission station on the Sarayacu, a tributary of the Ucayali.

The tribes whom the author names as inhabiting the banks of the Ucayali and Quillabamba are the Quichuas, the Antis, the Chontaquiros, the Conibos, the Sipibos, and the Schetibos. Of these, only the first three, along with the Aymaras, and two or three tribes scattered through the valleys of Bolivia, does he recognise as representing his "Irano-Aryan" race. Most of the other tribes he believes represents his Mongol or Tatar race, the colonising element; while the Carib, Tupi Guarani, and other races, are in his opinion only various

genera derived from the above-named mother families. We doubt whether this sweeping and easy way of grouping the American native races will stand the test of rigid ethnologic investigation; we suspect it will require much wider data than M. Marcoy had at his command to settle the question satisfactorily. The facts he gives, however, concerning the various tribes with which he came in contact, appear to us to be of considerable value. His descriptions of the peoples, the manners and customs, *physique*, traditions, movements, religious beliefs, vocabularies, &c., are all contributions to science, which the discriminating ethnologist will no doubt know how to make use of.

With regard to what must be considered as the proper source of the Amazon, M. Marcoy agrees so far with Mr. Squier, one of the latest writers on the subject, or rather with Dr. Santiago Tavares, of the Peruvian Hydrographic Commission, that it is not the Marañón. Dr. Tavares decided that as the Ucayali has greater volume and length than the Marañón, the former must be regarded as the Rio Madre del Amazonas. M. Marcoy had long before this concluded that as the Apurimac, a principal tributary of the Ucayali, is seventy-five miles longer than the Quillabamba or Urubamba, the upper part of the Ucayali, the former ought to be regarded as the real source of the Amazon. Several attempts have in recent years been made to discover if any of the many upper tributaries on the right bank of the Amazon could be made available for navigation by steamers, but, so far as we have learnt, with disappointing results, so that it is doubtful if any of these immense tributaries can ever be used as pathways for commerce.

During his slow progress down the Amazon, M. Marcoy frequently halted on its banks, visiting the mission stations, the half-civilised settlements of Brazilians and half-breeds, and the villages of the Indians. He also explored the mouths of some of the rivers flowing into the Amazon, and some of those curious natural canals which unite the main stream with many of its tributaries a considerable distance above the latter's *embouchure*. It is well known that the waters of some of the Amazonian tributaries, as the Rio Negro, are of a very dark colour, resembling coffee. We do not know that this has yet been satisfactorily accounted for; it can hardly, it would seem, be owing to the nature of the ground over which the rivers flow, as this is of very diverse kinds. M. Marcoy declares that when this water is looked at through a transparent vessel, it is perfectly limpid and colourless; only in cases where the current was slow or imperceptible, it had a brown tint. Animals of all kinds abound in and around these curious waters.

M. Marcoy made a careful exploration of the delta of the Purus, a large tributary on the right bank of the Amazon, by which he ascertained that the river has only one *embouchure*, the other openings being really only natural canals. M. Marcoy's knowledge of the hydrography of the south side of the Amazon seems to be clear and accurate, and is certainly extensive, and his frequent dissertations on the subject are worthy the attention of geographers, if they have not already gained it. One of the most valuable features of his work is the set of splendid maps which are prefixed, showing in minute detail the topography of his route.

We must leave M. Marcoy to find his way to Para, and accompany Mr. Keller in his journey up the Madeira. While we certainly think that in regard to the points to which we have referred the value of M. Marcoy's work is capable of being enhanced, still on the whole it must be regarded as deserving to occupy an honourable place among works of travel. It is essentially a popular work, and we hope it may have an extensive sale and many readers, as it contains a vast amount of really valuable information concerning the geography, topography, natural history, and ethnology of Peru and the Upper Amazon. Messrs. Blackie have done well in publishing an English translation, which has been remarkably well done by Mr. Rich.

(To be continued.)

#### MOGGRIDGE'S "HARVESTING ANTS AND TRAP-DOOR SPIDERS"

*Supplement to Harvesting Ants and Trap-door Spiders.*

By J. Traherne Moggridge, F.L.S., F.Z.S. With specific descriptions of the Spiders, by the Rev. O. Pickard-Cambridge. (Reeve and Co., 1874.)

MR. MOGGRIDGE'S original work was reviewed in NATURE, vol. vii. p. 337, and we have already a mass of additional matter, paged continuously so as to form one volume when bound up with the first part. Only twenty pages are here devoted to the ants, yet we find several observations of great interest to the philosophic entomologist. Thus, the actions of lizards and tiger-beetles in attacking the ants were closely observed. The lizards only eat the winged males and females, but show great fear of the workers, always keeping out of their way; and the workers protect the winged ants by surrounding and swarming over them, so that the lizards can only occasionally dash at an outlying straggler. The Tiger-Beetle (*Cicindela*) devours the workers, but only attacks them with great precaution, keeping out of the way of the main body and seizing stragglers by a bite just behind the neck. If it fails to seize them in this exact spot it leaves go again, evidently knowing that if the ant's jaws once close on any part of its legs or antennæ they will never leave go, even after death. These observations apply to the two species of South European Harvesting Ants, *Atta structor* and *A. barbata*, and they furnish a clue to the use and purport of the large bodies of workers, which act as guards to the males and females. They also explain the use of the spines, hooks, and bristles with which so many of the weaker forms of ants are armed, as well as the occurrence of a proportion of soldiers—large-headed workers whose only function is to attack and drive away certain specially dangerous enemies. Some of these large-headed workers are essentially a huge pair of jaws with just enough body to carry them about, and whose sole object in life is to fasten on some special enemy and sacrifice themselves for the good of the community. The most important problem remaining for solution in connection with these harvesting ants is, how they contrive to keep the seeds in their granaries from germinating. Mr. Moggridge has proved that formic acid or its vapour has no influence, that the presence of the ants is necessary to prevent germination, but that their presence alone does not prevent



it. Is it not probable that the whole secret consists in the ants continually using for food those seeds which begin to germinate, and that there always remain many seeds whose germination is delayed?

The remainder of the volume is devoted to Trap-door Spiders, many new species of which have been discovered, and much curious information obtained as to their habits. The spiders and their nests are illustrated by figures which are models of accuracy, and far surpass in delicacy and finish those of the first volume, good as those were. There are some interesting remarks about the British Nest-making Spider (*Alypus sulcari*), which has very rarely been observed, but which, now attention is called to the subject, will no doubt be found to occur plentifully in the South of England. The new double-tubed and double-doored nest now first described is the perfection of insect architecture; and being constructed by a single insect is far more indicative of intelligence, mechanical skill, and reasoning power, than the habitations of ants or bees.

This volume is a striking example of the way in which the most confirmed invalids may employ and enjoy themselves; of the marvellous interest that attaches to the minute observation of the habits of many of the lower animals; and of the vast field for discovery that is still open to observers. It will long remain a standard work on the subject of which it treats, as well as a worthy memento of the enthusiastic and amiable naturalist whose early departure from among us will be so widely deplored.

A. R. W.

### THE UNIONIDÆ

*Observations on the genus Unio, together with descriptions of new species in the family Unionidæ.* By Isaac Lea, LL.D. (Philadelphia, 4to.)

ALTHOUGH no date of publication is given, the last paper contained in this volume appears to have been read on the 3rd of February, 1874. It is a goodly volume of seventy-four pages, and twenty-two beautiful plates.

The number of this volume (xiii.) shows the extent to which the octogenarian, but still indefatigable author, Dr. Lea, has prosecuted his favourite study. He tells us in the Introduction: "In my twelfth volume I mentioned the number of North American species (Unionidæ) then known to be 772. By adding sixty to these, we have the number 832 species." And he remarks that "these do not by any means constitute the whole number of existing species; many of the smaller streams falling into our large rivers have not been explored, and these when well searched will unquestionably produce new forms of this numerous and interesting family."

Now it seems to us that the little word "forms" thus innocently used must disarm every conchologist of that weapon of criticism (species-making) with which Dr. Lea has been so often and so mercilessly assailed on this side of the Atlantic. Substitute "form" for "species," and what is there to prevent the European Unionidæ attaining a more respectable position as regards number than they do at present? In Great Britain we can show only five species, besides sixteen named and well-marked varieties.

In Germany, according to Kreglinger, there are fifteen species (including some of our varieties), and twenty-nine named varieties. The number could be increased almost *ad infinitum* by reckoning every distinct form from each river, stream, lake, canal, and pond in which the Unionidæ are found; and we should lose one test of specific difference, which consists of ignoring all variation of shape caused by habitat, and which induces us to believe that undoubted species are those that live together without any intermingling or gradation. But whether all the North American Unionidæ are called "species," or "varieties," or "forms," Natural History and Conchology in particular are under a great obligation to Dr. Lea for his admirable works. One, perhaps not the least, merit is his symmetrical method of description, the characters of every species being given in the same relative order, so that they can be readily compared and the differences between the several species more easily ascertained. This is certainly important in his case; because some of the figures on the same plates bear a rather suspicious resemblance, e.g. those of *Unio globatus* and *subglobatus*, *U. tuscumbiensis* and *radiosus*, *U. crudus* and *pattinoides*, *U. yadkinensis* and *conasaugaensis*, *U. amplus* and *insolidus*, *U. rostellum* and *exacutus*, besides *U. subparallelus* and *basalis*. The above-named species are compared by the author, not with each other, but with different species.

Another reflection occurs to us on the perusal of this work; and that is as to the division of labour. A universal naturalist is now an extinct animal; and the region of biology becomes every day more and more subdivided into separate fields of investigation. Thus, in the Mollusca Mr. Davidson restricts himself to the Brachiopoda, Dr. Lea to the Unionidæ, and Dr. L. Pfeiffer to the Pulmonobranchia. Every other department of zoology, as well as of botany, has its own votaries for different orders and even families; and it is in this way that knowledge is at present advanced, not by some great Coryphæus, but by many less-gifted persons who have the opportunities and inclination

"To labour and effect one thing specially."

### OUR BOOK SHELF

*La Vie; Physiologie Humaine, appliquée à l'Hygiène et à la Médecine.* Par le Dr. Gustave le Bon. (Paris: J. Rothschild, 1874.)

MOST authors compose their works first, leaving the preface until the last thing, in order that they may appreciate the full influence of their detailed study when making the generalisations with which they feel bound to start their volume. We have no reason to think that the author of the work under notice is any exception to this rule. In the nine hundred or so pages of his book he explains in a clear and very intelligible manner many of the most important facts and theories of the science of physiology; in some parts introducing improved methods of illustration, in others not quite recognising the most recent advances which have been made, even by his own countrymen. Particular stress is laid, throughout the work, on the bearing of the points discussed on everyday life, on hygiene, and on pathology; in all of which the author, from his experience in the routine of practice and the recent Franco-German war, in which he was engaged in active ambulance service, is able to speak with authority. There are two other points in which the work is

slightly different from most text-books of the subject, one being that a short account is given of the history of most of the physiological discoveries of importance, which is generally neglected in works of similar character, notwithstanding the additional interest which is thereby introduced. The other point is, that an account is given of the anatomical construction of the organs whose functions are to be studied, by which means those who have not, as medical students, gained the necessary amount of knowledge of anatomy to make clear their fundamental notions, can read on and understand without reference to other works.

In the preface Dr. Le Bon enters into a short account of the aims and objects of the study of physiology. He remarks that "it is with profound wisdom that the philosophy of the ancients epitomised what ought to be known by man, in the maxim, printed in golden letters on the doors of their temples, *Know thyself?*" We cannot, however, in any way agree with this physical distortion of the proverb, and think that the endeavour to place physiology on such a footing will never lead to successful results. The subject is not taught in schools, and it is true that the youth during several years of his life has, instead, been a student of the past, in company with the heroes of Greece and Rome. "The time has arrived for him to make use of his knowledge. He enters the business of life. He has to instruct the masses, lead the multitude; yet, of the nature of men, of their instincts, of their passions, he is absolutely ignorant." Notwithstanding all this, we must differ from our author in assuming that a thorough knowledge of the human organisation is indispensable, or even useful, in supplying the deficiency indicated; and there are many, we think, who will agree with us. No better proof that such is the case can be adduced than the medical profession itself. Its members are all more or less acquainted with the most important physiological facts and theories; supplemented, which is much to the point, with a thorough anatomical knowledge. Nevertheless, it is not to the medical profession that we are accustomed to look for moral philosophers, politicians, or novelists, but rather for thorough scientific workers, and an overwhelming percentage of nonentities, as far as the world at large is concerned. Statistics as to the average length of life amongst medical men would hardly show any advantage in their favour, and as patients they are notably unmanageable. As an education, physiology is therefore, no doubt, as good as any other science, but its further value is a delusion and a snare. It has been our object, on several occasions, to ascertain the amount of information as to the mechanism of the organ and of the piano possessed by some of the most accomplished musicians, and in nearly every case we have found that they are perfectly ignorant of acoustics and the mechanical construction of the machinery they are employing. And yet is not *Know thy instrument* at first sight as applicable to the musician as *Know thyself* to humanity at large? How few of us could pick to pieces and reconstruct a clock or watch, and yet how many of us have never missed a train in our lives!

These remarks are not made in disparagement of physiology, but in opposition to the misleading argument adopted by several others as well as the author of the work before us, to the injury of science itself in the estimation of the public at large, because of the false expectations it raises.

#### LETTERS TO THE EDITOR

[The Editor does not hold himself responsible for opinions expressed by his correspondents. Neither can he undertake to return, or to correspond with the writers of, rejected manuscripts. No notice is taken of anonymous communications.]

Fossil Remains of the Fallow Deer found in Malta

REFERRING to Dr. Jettettes' monograph on the Distribution of the Fallow Deer, translated by Mr. Sclater (NATURE, vol. xi., p.

71), it may be interesting to record that fossil exuvie referable to *Cervus dama* were discovered in Malta within the last few years. From inquiries I learn that they were found in a rock fissure impacted amongst the red soil which usually fills all the numerous rock rents of the island, where also fossil elephants' remains have been met with. The exuvie in question were sent to the late Mr. W. Flower, F.G.S., and subsequently examined by Mr. Busk, Mr. Boyd Dawkins, and myself. They contain fragments of long bones and several entire feet bones and teeth, referable to small-sized adult individuals of the Fallow Deer. There is, besides, the molar of *Equus* and a canine referable to *Canis*, from the same situation.

The mineralogical aspects of the specimens are similar to those of the Quaternary fossil fauna of the island, but this is, as far as I can discern, the first instance of fossil remains of *Cervus* and *Equus* having been discovered in Malta or Gozo. Canine teeth of the same dimensions as the above, and referable to *Canis*, were found by Admiral Spratt and myself in conjunction with teeth and bones of *Hippopotamus pentlandi*, from the Malak Cavern of Malta.

Royal College of Science,  
Dublin, Jan. 21

A. LEITH ADAMS

#### Electric Conductivity of Nerves

In a recent number of NATURE (vol. x. p. 519) the reviewer of "The Protoplasmic Theory of Life" states broadly that few physiologists will agree with the statement in the book that the nerves are not better fitted for the conduction of electric currents than the other moist tissues, and that they possess no demonstrable apparatus for insulation of these currents. There must be some misunderstanding here, for I have adduced proofs from Dubois-Reymond, Ranke, Fick, and others, and I believe all physiologists of note concur in the view as represented by me. The reviewer has apparently overlooked the circumstance that one of the principal points in the chapter was the distinction of the conveyance by nerves of the stimulus caused by electricity, and the mere conduction of an electric current, for he says "there is not the least doubt that it is through the nerve-fibres that electric stimulation will most readily and most powerfully affect muscular fibres at a distance." No one, I imagine, does doubt this, but it is not at all the same thing as saying that the nerve is the best medium for affecting the muscle owing to its superior power of conducting electricity, for it may also mean that the nerve is susceptible to the stimulus of electricity. This is, indeed, sufficiently shown by the fact that a mechanical stimulation of the nerve will have a similar effect, while we do not attribute to the nerve any superior power of conducting mechanical force. Permit me to refer to the additional light thrown on the question in the recently published work of Prof. Vulpian ("Leçons sur d'Appareil Vaso-moteur," 1875). It had been asserted by Legros and Onimus, that on passing a galvanic current through a nerve containing vaso-motor filaments, the ascending current caused contraction, while the descending ones produced dilatation of the capillary arteries. The experiments of Vulpian and Carville yielded results not in accordance with this statement, and both currents were found to cause contraction. Vulpian explains this discrepancy by pointing out that Legros and Onimus assumed to act on particular nerves by sending the current through the skin and subjacent parts. "Not only," says Vulpian, "are we not authorised to believe that we act on these nerves by this mode, but, in addition, it is evident that we determine excitation of all the tissues comprehended in the current, the skin among others, and that that excitation may provoke reflex vascular dilatations which complicate the results" (p. 114). To perform the experiment properly, it is necessary to secure isolation artificially by cutting the channels of reflex vaso-motor action. Again, if you electrically the sciatic nerve in a dog which has been curarised, no contraction of the voluntary muscles to which it is distributed takes place. And in paralysis of the radial nerve in man from cold, the power of volition over the muscles supplied by it is lost, while the sensory and vaso-motor filaments bound up in the same nerve retain their functional activity. In those cases the power of conducting electricity is not impaired, nor is it indeed in the dead body even; but here, as expressed by Vulpian, "the musculo-motor filaments have lost their normal aptitude to cause the muscular bundles to pass from the state of repose to the state of activity" (p. 122). What that "normal aptitude" consists in is still a question, but it is certainly not the power of conducting electricity, although a knowledge of the latter is of great importance in judging of Dr. Beale's theory of muscular contraction.

Dr. Beale, as is well known, still holds to the opinion that the nerve-force is electricity, and that the nerves have not only the power of conducting electricity but of evolving it as a vital act on stimulation from the little masses of protoplasm, bioplasm, or living matter with which the nerve-cords are studded. Although there are many objections to this theory, still the badly-conducting power of the nerves for electricity does not appear an insuperable one when we think of the nerve-force merely as a stimulus, for the quantity of a stimulus necessary to rouse up vital action bears an infinitesimally small proportion to the result. But when the same force is assumed to be the efficient cause of muscular contraction, the question assumes a very different aspect. In Dr. Beale's theory the muscular fibre proper is held not to contain protoplasm, and to be incapable of living action or of evolving force, the contraction being produced by inductive electric action on the sarcous particles, which causes them to change their position and thus approximate the ends of the muscular fibre. The source of the electricity is said to be the protoplasm masses contained in the muscles, in continuous contact with the motor nerves, and it is conveyed to the muscular fibres by loops of fine nerve-fibres crossing them in various directions. In this theory, even supposing insulation to be complete, it is obvious that the conducting power of the nerve-fibre becomes of supreme importance, because not the stimulus only, but the whole force of muscular motion, must be conveyed by it. Now, the nerve-cords do conduct electricity certainly, but so many million times worse than metallic wires, that the loss of energy by transformation into heat must be enormous. Such a loss is inconsistent with the economy of nature and with the actual facts; therefore, unless the nerve-force is a specific force different from surface-electricity, galvanism, and magnetism, though analogous to them, and probably easily convertible into electricity, Dr. Beale's theory cannot be upheld. I have not yet seen any reply by Dr. Beale to this objection.

JOHN DRYSDALE

Liverpool

#### Kirkes' Physiology

In a letter headed "Kirkes' Physiology," in NATURE of last week, signed "W. Percy Ashe," your correspondent would not appear to be practically acquainted with the semi-lunar valves at the base of the great vessels emerging from the heart, for his arguments, although perfectly correct in themselves, and based on well-known physical laws, do not, I submit, apply in the instance he quotes, for the simple reason that the conditions necessary for their application do not exist.

Let us consider briefly the shape of the sinuses of Valsalva during the diastole of the ventricles of the heart. For our purpose we shall be sufficiently correct in describing them as three inverted, empty, and slightly truncated pyramids; one surface, the outer one, of each, is formed by the arterial coat, whilst the other two surfaces, constituting the semi-lunar valve, are in apposition with the corresponding surfaces of the other two valves. Now, the pressure over the whole surface of the sinus may be divided into four pressures, one sustained by each of the three sides, and one by the bottom.

The three sides sustain an equal pressure, but the two inner ones constituting the valve are by far the weakest, and the pressure on each of these is really supported by an equal pressure on the corresponding surfaces of the other two valves, and consequently may be considered as *nil*; whilst the pressure on the third side is resisted by its own strength, and it is formed, as I have said, by the wall of the artery, which is particularly strong at this point.

The remaining pressure is sustained by the bottom or truncated apex of the pyramidal pouch. This pressure is greater in proportion to its extent of surface than the other pressures—the column of fluid being higher—and this surface directly rests on and is *partially embedded* in the structure of the ventricle, which must thus undoubtedly support it.

Therefore the idea that "the reflux is most efficiently sustained by the muscular substance of the ventricle," which is the main part of Mr. Savory's theory, is most directly confirmed by the actual construction of the valves, and which your correspondent may see for himself by making a vertical section through the aortic valves in a sheep's heart.

As at the time of the greatest pressure on the valves the ventricles are dilating, it follows that they cannot reduce the area of the valves at that time, as your correspondent in his last remarks would seem to imagine, nor in fact can they ever do so.

4, Granville Place, Blackheath

E. PRIDEAUX

#### The Rhinoceros in New Guinea

LIEUT. SIDNEY SMITH, late of H.M.S. *Basilisk*, reports that while engaged in surveying on the north coast of Papua, between Huon Bay and Cape Basilisk, being on shore with a party cutting firewood, he observed in the forest the "droppings" (excrement) of a rhinoceros in more than one place, the bushes in the neighbourhood being also broken and trampled as if by a large animal. The presence of so large an animal belonging to the Asiatic fauna in Papua is an important fact.

Skins of a very fine species of Bird of Paradise, having plumes of a brilliant red in place of the yellow plumes of the common species (*P. apoda*), were obtained from the natives further to the eastward.

ALFRED O. WALKER

Chester, Jan. 21

[We should be inclined to doubt very seriously the occurrence of any rhinoceros in New Guinea. At any rate, the *important fact*, as our correspondent terms it, cannot be considered as established.

The red-plumed Paradise Bird of the south of New Guinea has been named by Mr. Sclater, *Paradisaea raggiana* (P. Z. S., 1873, p. 559), from skins sent home by Mr. D'Albertis.—ED.]

268

#### Thomson's "Malacca"

IN your review (NATURE, vol. xi. p. 207) of Mr. J. Thomson's very interesting work on the "Straits of Malacca, Indo-China, and China," you have justly acknowledged that the author "makes no pretension to have travelled in the interests of science, but only to be a photographer and an observer of the ways of men;" and as his excellent book will no doubt have a wide circulation, it may perhaps not be an unthankful office to correct two statements with reference to the natural history of Penang, which I had some opportunity of studying during a sojourn there of some eighteen months.

Our author, describing the noise made by the insects on Penang Hill, says: "One beetle in particular, known to the natives as the 'trumpeter,' busies himself all day long in producing a booming noise with his wings." Had Mr. Thomson succeeded in observing one of these insects whilst "booming," which he states he was unable to do, I think he would have found the musician to have been no beetle at all, but one of the Cicadidae, and the sound not produced by the wings, but, as is generally known, internally, by the vibration of a membrane set into action by a special muscle. These insects are abundant at Penang, one species, *Dundubia imperatoria*, being particularly large, and which, with several other species, were taken by myself when there. It is nothing unusual for these insects to be wrongly described by natives, as we are told by Mr. Gervase F. Mathew, R.N. (in the *Entomologist's Monthly Magazine*), that in Tobago *Cicada gigas* makes a noise like the whistle of a locomotive; and he was told by the natives that the sound was that of the "tree-locust." At Surinam it is said *Cicada tibicen* is called the "harper," on account of its giving forth a sound like that of a harp.

Mr. Thomson also tells us (p. 35), when describing planter life in Province Wellesley, that the planters, when driving home at night from one estate to another, have the possibility of an encounter with an orang-utan, a rhinoceros, or a tiger. The orang, however, is not found there at all, and I know of no instance of an attack by a rhinoceros. In fact, that animal is so scarce that during my whole stay there the only report of one which I heard was that the animal's dung had been seen in the jungle. Tigers are still anything but scarce, but during my many nightly rides whilst living on the sugar plantations I am happy to say I never heard or saw one, nor was our roll-call ever diminished by that animal. The tiger there is a midnight prowler, but confines himself more to pigs, goats, and dogs. The wild animals are gradually being beaten back by the cultivation of the land, and the same may be said of even the insects. No doubt they abound in the centre of the peninsula, and there also, no doubt, may be found the Negro stock, of which our author has given us a good photograph as found at Johore.

The illustrations of this very interesting book are excellent, and photography seems to be doing for anthropology what spectrum analysis is still achieving for astronomy.

Streatham Cottage, West Dulwich

W. L. DISTANT

#### Bees and Flowers

My children noticed with much interest, last autumn, the curious manner that the bees attacked the flowers of the *Antir-*

*rhinum majus*, making a hole at the bottom of the corolla of the flower near the stalk, and so getting at the honey from the outside. It was too late in the season to be able to observe it much, or often, but we are pleased to find others have seen it too.

In Sir John Lubbock's lecture at the London Institution he said some "humble-bees sucked the honey of the French bean and scarlet-runner in the legitimate manner, while other bees cut a hole in the tube, and so reached it surreptitiously."

This flower I speak of is one with the corolla much more marked than those the lecturer quoted. Next season we will hope to watch it again, and see if it only happens late in the year, for the injured blossoms seemed to wither very soon after the incision was made.

MARY J. PLARR

Tunbridge, Jan. 9

#### Iron Pyrites.—Curious Phenomenon

SOME iron pyrites exhibited in a particular case in the Maidstone Museum have crumbled into a coarse, finely-divided mass. The specimens have been exhibited for about two months, and the decomposition has been effected in that time. Some other specimens recently removed from another case are becoming soft.

Could any of your readers account for this, and has such a thing ever been observed-before?

FREDERIC CASE

Maidstone, Jan. 19

#### OUR ASTRONOMICAL COLUMN

ANTARES AS A DOUBLE STAR.—The small bluish companion of Antares was detected by Mitchel at the Observatory of Cincinnati in July 1845. Measures taken by him in the summer of 1846 are published in No. 4 of his *Sidereal Messenger*. They gave the distance  $2''.52$ , the companion preceding on the parallel, at the epoch 1846.59, and Mitchel thought this distance was half a second greater than at the time he discovered the small star. He mentions that on the 13th of August, 1846, he saw the star distinctly at 5.30 P.M., "the sun shining, unobstructed by clouds or mist." Early in the year 1848, Antares was repeatedly measured by Bond with the great refractor of Harvard College, and by Dawes in this country. Their mean result, weighted according to the number of nights, is—

1848.24 : Position ...  $273^{\circ}71'$ . Distance ...  $3''574$ .

The proper motion of the large star, though small, is still sufficiently sensible. Leverrier (*Annales*, tome ii.) assigns for the secular motion, —  $05^{\circ}09'$  in Right Ascension, and —  $3''36$  in Declination. If the above angle and distance are brought up to the present time with these values, we find on the assumption of merely optical proximity of the companion—

1875.25 : Position ...  $288^{\circ}8'$ . Distance ...  $3''54$ .

We would suggest that the star should be carefully re-measured, now that it is drawing away from the sun's place in the morning sky, to decide on the optical or physical connection of the components. Dawes' last measures in 1864 certainly rather favour the latter view, but they were made on a single night, and the object is one of difficult observation. It will be seen that on the assumption of optical duplicity, the distance is just now very nearly stationary, but the change of angle during the last twenty-five years amounts to 15 degrees, and will be easily confirmed or otherwise.

THE "TEMPORARY STARS" OF TYCHO BRAHE AND KEPLER.—The position of the famous star of 1572 in the constellation Cassiopea, with which Tycho's name is usually associated, has been determined with all the precision that his observations admit of, by Prof. Argelander, of Bonn. His place, reducing to the commencement of the present year, is in

Right Ascension ... .. oh. 17m. 52s.6

North Declination ... ..  $63^{\circ}27'18''$ .

Near to this position is a star of about the eleventh

magnitude, which, by micrometrical comparison with two of its neighbours meridionally fixed, is found to have for the same epoch,

Right Ascension ... .. oh. 17m. 52s.1.

North Declination ... ..  $63^{\circ}26'24''$ .

It is, therefore, distant less than one minute of arc from the most reliable position of Tycho's star that can now be assigned. On this account alone it would be worthy of attention, but we are able to state, further, that during the last four years this small star has exhibited slight fluctuations of brightness at irregular intervals, which increases the probability of its identity with the star of 1572. It may also be noted that in August 1874 there was a decided ruddiness in its light.

Kepler's observations of the star which suddenly assumed such extraordinary brilliancy in the constellation Ophiuchus in the autumn of 1604, are contained in his work "De Stellâ novâ in pede Serpentarij;" but the best position we possess is doubtless that deduced by Prof. Schönfeld of Manheim, from the observations of David Fabricius. For the commencement of the present year we have

Right Ascension ... .. 17h. 23m. 8s.9

South Declination ... ..  $21^{\circ}22'16''$ .

This position is probably liable to greater error than in the case of Tycho's star.

The nearest object at the present time is a star of the twelfth magnitude (or rather fainter), following the above place  $65'$  and  $2\frac{1}{2}''$  south of it, which has not sensibly varied during the last few years, but it is a suspicious circumstance that Chacornac has entered upon his chart No. 52, a tenth magnitude about 8s. preceding Schönfeld's place, and nearly on the parallel of declination, which is not now visible, or was not last summer. The neighbourhood requires to be closely watched. The observer may set the circles of his equatorial for Oeltzen 16872, R.A. 17h. 23m. 34s., N.P.D.  $111^{\circ}23'$ . The observations for Chacornac's chart were made between the 31st of May and 12th of August, 1861.

THE ZODIACAL LIGHT.—On the evening of Sunday last, the 24th inst., a surprisingly bright display of this as yet problematical phenomenon was exhibited. There was a repetition on the following evening, but in a less favourable sky. The light had the usual yellowish or pale lemon tinge of the more notable exhibitions in these latitudes. The axis of the light appeared to pass  $\lambda$  Piscium, and the vaguely-defined apex was situate somewhere about  $\lambda$  Arietis, but it was not possible to locate it with anything like precision. The light was broad and of a deeper, perhaps, ruddy tint near the horizon. The display to which we have adverted, excelled in brightness any that has been witnessed in the neighbourhood of London for many years. It appears very probable that opportunities for favourable application of the spectro-scope may be afforded in the dark evenings of the present and following months.

#### PLANETARY THEORIES \*

THE theory of Neptune, which I have the honour of presenting to-day to the Academy, completes the *ensemble* of the fundamental theories of the planetary system, of which the first dates back to September 16, 1839, thirty-five years ago.

The numerous developments added year after year are all mentioned in the organ of the Academy. Some of them figure only by their titles, and as they are scattered through a great number of volumes, the Academy will not doubt permit me, at the moment when I have arrived at

\* "New Theory of the Motion of the Planet Neptune; with Remarks on the *ensemble* of the Theories of the eight principal Planets, Mercury, Venus, the Earth, Mars, Jupiter, Saturn, Uranus, and Neptune." A paper read before the French Academy of Sciences by M. Leverrier, December 21, 1845.

the end of this long discussion, to present a precise but succinct *résumé* of them.

In 1849, after I had already been engaged for ten years in the work, and the better able to estimate the difficulties, I presented its essential conditions in terms in which I have no alteration to make.

None of the tables, let us say, intended to represent the movements of the planets, accord rigorously with the observations. The most precise, those of the Earth and Mercury, are not so accurate as could be wished. I do not speak of those irregular discrepancies which the uncertainty inseparable from every physical measurement necessarily introduces between observation and calculation, but rather of those systematic errors whose variation follows a determined law, the real existence and regularity of which are prominent in the *ensemble* of the work of the different observatories, and for which theory alone can be blamed. These inaccuracies ought to engage our earnest attention; no doubt they are inconsiderable, but, on the other hand, they are everywhere present, and their smallness does not authorise us to neglect them.

It would assuredly not be very serious in itself that our astronomical tables should make an error of half a second in the time of the passage of a star on the meridian, if the importance of this error did not lie in its degree of certainty rather than in its magnitude. Every discrepancy betrays an unknown cause, and may become the source of a discovery. If these errors should increase considerably with the time, we may, it is true, await their complete development in order to read with greater certainty, in their onward progress, the cause which produces them; but, first, we should thus leave to posterity the task of perfecting science and the advantage of discovering new truths. Moreover, certain extraneous influences may manifest themselves by effects always slightly sensible; and if we neglect these effects, the cause on which they depend will remain for ever unknown.

The theory of the motion of a planet rests upon the hypothesis that each planet is subject only to the actions of the sun and of the other planets, and, moreover, that these actions are exercised conformably to the principles of universal gravitation.

But the consequences of the Newtonian law have not been, in many respects, deduced with sufficient rigour; and, on this account, we are not in a condition to decide if the disagreements evident between observation and calculation are due solely to analytical errors, or rather if they are partly due to the imperfection of our knowledge of celestial physics.

It will be necessary, then, to take up again the mechanical theories of the motions of the planets, and to rigidly examine them to their most remote consequences, before we are able to effect a decisive comparison with observations. This is what has been done.

Let us rapidly state that the general developments have been the subject of five memoirs, presented and published in 1840, 1843, 1849, and 1855.

The formulae relative to secular irregularities have been treated particularly in the memoirs of 1840 and 1841.

The same subject has been handled, in a more general and more complete manner, in the paper communicated to the Academy on Nov. 11, 1872, concerning the four great planets, Jupiter, Saturn, Uranus, and Neptune.

The theory of Mercury, presented in 1843, since completely revised, was only definitely completed in 1859.

The theory of Venus was given in 1861.

That of the Sun (the Earth) in 1853 and 1858.

That of Mars in 1861.

The theory of Jupiter in 1872 and 1873.

That of Saturn in 1872 and 1873.

The theory of Uranus, given in 1846, and connected with the discovery of Neptune, was the subject of a new work presented on Nov. 15 last.

Finally, the last theory, that of Neptune, is offered by us to the Academy to-day.

The theories of Jupiter, Saturn, Uranus, and Neptune have the peculiarity that they are developed in functions of indeterminates, so that their use may be prolonged during an unlimited time.

The theories once established, it will be necessary to compare them with the long and valuable series of meridian observations devised by Roemer, instituted for the first time at Greenwich, in September 1750, by the famous observer Bradley, and continued since then to our own days in the great observatories. But as the positions of the moving stars are connected with the fixed stars, it is evident that it will be necessary also to be assured of the relations of the stars among themselves, with respect to the equinox and the ecliptic. This necessity is particularly imposed in respect to right ascensions, on which specially depends a knowledge of the motions of the planets. The work was effected in the memoir of April 5, 1854, for the series of observations of Bradley. This was a delicate subject, for it necessitated the revision of the labours of Bessel, given in his work entitled "*Fundamenta Astronomiæ*." We have had to propose various corrections in the positions of the fundamental stars, and the verification of the accuracy of these corrections was put to the test (*au concours*) in Germany. The result confirmed all our determinations. Consequently they have served us in establishing with certainty the positions of the stars of comparison during the 120 years of observations which we have had to consider.

The comparison of the motions of Mercury with the theory given by us in 1843 did not present from the first a satisfactory result. The transits of Mercury across the Sun furnish data of very great precision, but which it was not possible completely to satisfy.

This first result fills us with uneasiness, it is known. May not some error in the theory have escaped our notice? New researches, in which everything was tested in various ways, only tend to convince us that the theory was accurate, but that it did not agree with the observations. Years passed, and it was only in 1859 that we managed to discover the cause of the established anomalies. We discovered that they are all connected with a very simple law, and that it is sufficient to increase the motion of the perihelion by  $30\frac{1}{2}$  seconds per century to reduce everything to order.

The displacement of the perihelion acquires thus in the planetary theories an exceptional importance. It is the surest indication, when it must be increased, of the existence of a cosmical matter yet unknown, and circulating like other bodies around the Sun. It matters not whether this matter may be agglomerated into a single mass, or disseminated in a multitude of meteorites independent of each other. Provided that its parts all circulate in the same direction, these effects combine to impress upon the perihelion a direct motion.

The consequence is clear. There exists in the neighbourhood of Mercury, between the planet and the Sun, without doubt, a matter, a material hitherto unknown. Does it consist of one or more small planets, or of meteorites, or even of cosmical dust? The theory does not pronounce on this point. On many occasions, trustworthy observers have declared that they observed signs of the passage of a small planet across the Sun; but nothing definite has been reached on this subject.

We should not, however, doubt the accuracy of the conclusion. We shall see, in fact, the same analysis applied to the discussion of the observations of Mars lead to an analogous result, and this result found fully verified.

Bessel has said of the theory of the sun that it has not made the progress we should have expected from the great number and the value of the observations. This estimate has for long troubled our mind, too trustful of this supposed accuracy of the observations. After

having revised and discussed anew the observations of the Sun, made since the time of Bradley at Greenwich, at Paris, at Königsberg, to the number of 9,000, we have been forced to quite a different conclusion, viz., that the observations of the Sun are far from what they ought to be, on account of the systematic errors which affect them, and that there is no discordance between theory and observation which may not be attributed to errors in the latter.

In spite of all, the discussion of the observations of the Sun led us hence to an important result connected with the great question which agitates, at this moment, the scientific world; a result which surprised ourselves, so much had the determination of the parallax of the Sun, deduced by the director of the Berlin Observatory from the Transits of Venus in 1761 and 1769, inspired a false confidence. I arrived at the conclusion that the parallax of the Sun, estimated then at  $8'57''$ , ought to be increased by the 25th part of its value.

Soon after, the comparison of the theory of Venus with the observations led to the same result, the necessity of increasing by  $\frac{1}{25}$  the parallax of the Sun.

Finally, the theory of Mars led, in its turn, to a conclusion not less precise. It was proved that we could not account for the *ensemble* of the observations of Mars without increasing the movement of the perihelion by about one-eighth. This was the reproduction of the same fact as in the case of Mercury, and the conclusion to be drawn from it was the same, viz., that the planet Mars must be subject to the action of a quantity of matter till then neglected, and that it must be estimated at the eighth part of the mass of the Earth.

But then two hypotheses were possible, as we explained at the *séance* of June 3, 1861: either that the matter till then left out of the count resided in the belt of the small planets as a whole, or that it must be added to the Earth itself. In the latter case, and as a consequence, the parallax of the Sun must be increased by the 24th part of its received value, that is to say, that we would be led to the same result already deduced from the theories of the Sun and of Venus.

Meantime M. Fizeau has given a method for determining the speed of light, by a physical experiment, on the surface of the earth; and from this measurement, combined with the quantity of the aberration of the stars, we know that we can deduce the parallax of the Sun.

Foucault, on his part, had devised a plan of solving the same question by another method, and he was engaged in realising the experiment. I pressed him strongly to carry it into execution. We know that in the *séance* of Sept. 22, 1862, Foucault announced that he had fixed the rate of light at 298,000 kilometres per second; hence, by adopting the quantity of aberration determined by Struve, 8'86" resulted for the parallax of the Sun, a number corresponding to an increase of 1-30th of the received value.

M. Cornu, in the important paper read by him at the last sitting, resolved definitively the question by the employment of the method of M. Fizeau. He was good enough to refer to the determination which I presented to the Academy at the sitting of July 22, 1872, based on the celebrated and very exact observation of the occultation of the star  $\psi^2$  Aquarii by the planet Mars, an occultation observed in 1672 by the three great astronomers, Richer, Picard, and Röemer.

Moreover, we shall combine materials obtained from various points of view on this delicate question, and will further increase by discussion the great interest which will be presented by the materials collected with so much devotion by the various expeditions destined to the observation of the present Transit of Venus. For this reason, and because the method which results from the occultation of  $\psi^2$  Aquarii is present under a form precise and striking, we shall shortly ask permission from the Academy to

deposit the work in its hands, after having given it the necessary developments.

Jupiter and Saturn have given rise to a theoretic work the extent of which has been considerable, on account of the very great mutual perturbations of the two planets. The comparison of the theory of Jupiter with the observations has presented, after the proper modifications of the elements, a complete harmony. The tables of Jupiter have also been adopted by the editor of the *Nautical Almanac* to serve for the preparation of that important work. I owe to our *confrère* Mr. Hind, superintendent of the *Nautical Almanac*, the satisfaction of thus seeing adopted by the astronomical world the various tables of Mercury, the Sun, Venus, Mars, and Jupiter, so far as they have appeared.

The tables of Saturn are now constructed, and their comparison with the observations is almost finished.

The theories of Uranus and of Neptune being also completed, it only remains further to effect their comparison with the observations.

The profound knowledge which my excellent colleague M. Gillot, chief of the Bureau des Calculs, and member of the Council of the Observatory, has of these matters, and the devotion with which he has assured the laborious construction and comparison of the tables of Jupiter and Saturn, are to me a sure guarantee that the final work will be, whatever happens, carried out to the end.

#### RUSSIAN FORESTS

VEGETATION in the fossil or recent state forms the main source of the wealth and prosperity of most nations, either directly or indirectly: directly, in the case of the vast subterranean deposits of the remains of former plant-life in Britain, as also in the broad expanses of land covered with timber-trees in Russia. According to recent statistics\* the extent of the forests of Russia in Europe is about 442,897,500 acres, or forty per cent. of the whole area. The forests are very unequally distributed, and internal communication is still very imperfect in many parts of the empire; hence much of this wealth is at present unavailable. Every year, however, the facilities for transport are increased, and there is a corresponding augmentation in the amount realised. Nearly sixty-five per cent. of the forest land is situate in the four governments of the North—Archangel, Vologda, Olonetz, and Perm; this equals sixty-five acres to each inhabitant. The governments of the South are relatively poor in timber, and in some parts almost treeless; but since 1842 the forest administration has been engaged in remedying this defect by planting largely. Between 1866 and 1870 upwards of 20,000 acres were planted, exclusive of the action of private owners. The principal trees are the Scotch pine, spruce fir, larch, birch, lime, aspen, and oak. To these may be added for the governments of the South, though relatively playing an unimportant part in commerce, the elm, ash, beech, hornbeam, maple, various poplars and willows, &c. The value of the forest products exported in 1871 amounted to 16,026,553 roubles, of which more than one-third came to this country. But the internal consumption gives a better idea of the immense wealth of these forests. It is only possible to give an approximate estimate of the value, which Mr. Werekha states must be at the very least 265,450,000 roubles per annum. In Russia, wood is still either the only or the principal fuel used. The railways consume wood for fuel to the annual value of 7,200,000 roubles. Wooden drinking-vessels, platters and spoons, take the place of pottery and metal in many districts, except in the houses of the rich. Mr. Werekha estimates that forty million wooden spoons are made every year; but Mr. Weschniakoff, in his account of the domestic industries of Russia, puts the figure at thirty millions.

\* "Notice sur les Forêts et leurs Produits," etc. Par P. N. Werekha.

But the most destructive industry, so far as the forests are concerned, is the manufacture of bast mats, bark boots (*lapiti*), cordage, and other articles prepared from the liber or inner bark of the lime, birch, and willow, chiefly of the former tree. It is computed that 100,000,000 pairs of *lapiti* are made annually, each pair requiring the bark of four young trees; thus 400,000,000 trees are cut down every year for shoes! Lime-trees from five to ten years of age, and half-grown birch, are employed for this purpose. Such reckless waste is much to be regretted; and Mr. Werekha observes that the pines are tapped for their resin and bled to death in from ten to fifteen years, in the same way as the Landes of Gascony were denuded of their pine-forests during the last century.

The previously almost useless aspen, either for fuel or building, has attained to considerable importance within the last few years as a material for paper-making. There are already ten manufactories actively engaged in the preparation of this paper in Russia, and two in Finland; and as vast reserves of this tree have accumulated in the forests, it is expected to prove a source of great riches for many years to come. Timber, of course, is the most valuable article exported, though resinous products and bast mats bring in a large sum. The Scotch pine, spruce fir, birch (for coach-building), and the oak, are the principal and almost the only timbers exported. Speaking of the giant oaks of Russia, Mr. Werekha becomes almost sentimental, for they form the strength of British and French shipbuilders, and occasionally revisit their native country in a form by no means flattering to national pride, as the Russians are still very small shipbuilders.

#### THE INDIA MUSEUM\*

THE India Museum, at present located at Whitehall, has long been known for its extensive and valuable collections of Indian products, a collection too valuable, indeed, not to have been made more available, both for scientific and commercial purposes, than it has been. The removal, however, of the specimens to the galleries at South Kensington will bring them within the reach of ordinary mortals who have neither bodily strength nor inclination to make a pilgrimage to the topmost floor of one of the highest buildings in London.

The importance and value of these collections has to some extent been shown in the several reports which have from time to time been issued from the Foreign Office. Dr. Forbes Watson, as Reporter on the Products of India, has done much service in this respect, and Dr. M. C. Cooke, who has drawn up the present report, is no novice amongst Indian gums and resins, having gained an extensive experience from his long official connection with the Museum.

There are, no doubt, many products of the Indian forests that ought to be included in European commerce, but, from the want of a proper knowledge of their uses, have never established themselves in the market. Individually, we have often deplored the prevailing prejudice amongst commercial men in favour of old and well-known commodities, amounting sometimes even to the absolute rejection of new products, without giving such products a fair trial. Dr. Forbes Watson, in an introductory note to the report under consideration, in reference to this, says it should "be remembered that gums or resins sent over for valuation in the London market are necessarily subject to comparison and competition with the very best qualities of the same substances which come into any of the European markets, and that careful collection is not a too frequent characteristic of Indian products." Dr. Watson further points out that it is of very great importance to the existing and future trade of India that

\* Report by Dr. M. C. Cooke, on the Gums, Resins, Oleo-resins, and resinous products in the India Museum, or produced in India. Prepared under the direction of the Reporter on the Products of India. 1874.

samples should be sent home in sufficient quantity for report, since this is the only means by which they can be brought under the notice of competent authorities. For this purpose it is suggested that in the case of gums, resins, &c., quantities of from 20 lbs. to 25 lbs. would be sufficient for distribution amongst brokers and traders, as well as for analysis and experiments. The necessity, also, of obtaining accurate information on the botanical source of the plant yielding any particular product is strongly urged. The value of accurate specimens gathered at the time of collecting the article itself, whether it be gum, resin, wood, or fibre, must be apparent to everyone, and is strongly advocated in the article "Botany" in the "Admiralty Manual." In all cases such specimens should consist of leaves, flowers, and, where possible, fruits also, securely labelled and numbered, so that no mistake may occur.

This report of Dr. Cooke's is valuable, as it brings together nearly all that has been written on the gums and resinous products of India. The botanical synonymy of each species, with references, is first given; next, a short botanical description; then its habitat, native names, history, description, and uses; and finally, in the case of the most important products, references to the works where the subject has been treated of. Dr. Cooke has brought his report down to the most recent period, for we find under the genus *Garcinia*, of which the species are described as yielding gum, a description of *G. Griffithii*, with the following note:—"Anderson says of this plant that there is in Maingay's herbarium a plant very like it in habit, but described by him as having a circumsciss anther, which is cultivated in Singapore as the true gamboge of Siam. There still appears to be some doubt as to the source of Siam gamboge, which Dr. Hooker seems disposed to attribute to this tree." The fact is, that in the most recent revision of the order, *Garcinia Griffithii* of Anderson has been considered identical with *G. morella*, var. *pedicellata*, to which Siam gamboge has been referred by Hanbury, and which Dr. Hooker thinks has sufficiently distinctive characters to raise it to the rank of a species under the name of *G. Hanburyi*. Again, Dr. Cooke refers to the very recent work of Flüchiger and Hanbury, in which Siam gamboge is attributed to *G. morella*, var. *pedicellata*, as stated above. Indeed, throughout the report there are frequent references to the "Pharmacographia," but we are not a little surprised that Stewart and Brandis's "Forest Flora" is not quoted. Thus, for instance, at p. 24 of the report, the Marking Nut, *Semecarpus anacardium*, is dismissed with very few lines; while in the "Forest Flora" is an excellent description of the tree; of the wood, which "is full of an acrid juice which causes swelling and irritation, so that the timber cutters object to fell it unless it has been ringed for some time;" and of the fruit and the black varnish, which is prepared from the pericarp, and which is used mixed with lime-water for marking cotton. Small consignments of these fruits occasionally arrive in this country, and not long since a quantity of a very fine kind came into the hands of a London house.

J. R. J.

#### UMBELLULA, OR CLUSTER POLYP

ABOUT six months since (vol. x. p. 142) we referred to a letter from Prof. Wyville Thomson, in which he mentions having brought up from a depth of nearly 1,500 feet, between Prince Edward's Island and the Crozet (Kerguelen's Land), specimens of an Umbellula. When the  *Challenger*  was between the coasts of Portugal and Madeira, several specimens of another species of the same rare genus, but from a depth of about 2,000 feet, were also dredged up. The history of these curious Cluster Polyps is interesting. Some hundred and twenty years ago, and some one and twenty years before M. Kerguelen discovered the land now bearing his name,



Capt. Adriaanz, the master of the whaling-ship *Britannia*, being then in lat. 79° N., and about eighty miles from Greenland, on pulling up his sounding line, found two specimens of a large plant-like polyp clinging to it; the length of the stem of the larger specimen was six feet, and he noted that the expanded flower-like polyp which was at one end of the stem was of a fine bright yellow colour. Struck by their size and beauty, and the strangeness of such creatures living at a depth in the sea of more than 220 fathoms, he brought them home to his friend Mr. Dunze, of Bremen, who had been a pupil of the illustrious Haller. Mr. Dunze gave the smaller specimen to Christlob Mylius, a Professor of Botany at Leipzig, and the larger to Peter Collinson, F.R.S.; this latter gentleman gave it to John Ellis, of zoophyte fame, to describe, which he did in the Philosophical Transactions for 1752, accompanying his description with a plate. What became of this specimen is unknown. Mylius's one found its way into a collection in Göttingen, and was not to be found there by Pallas in 1766. No specimens being found for thus more than a century, an air of uncertainty hung round this Cluster Polyp, and its portrait, so often copied in our text-books, seemed to be all one was likely to know about it. It was, therefore, with the greatest delight that the writer of these lines, in the summer of 1872, saw two specimens of *Umbellula* in the Swedish Museum of Natural History at Stockholm; one rare object after another had been shown to him by Prof. Lovén; but the *Umbellula*, though the last, was not the least of the treasures accumulated therein by this esteemed professor, who stated that Mr. J. Lindahl had dredged them up during the expedition of H.S.M. *Insegerd* and *Gladdan* to the Greenland Seas in 1871. Within the last few days we have received from Stockholm a quarto memoir, "Om Pennatulid-slågten *Umbellula* af Josua Lindahl," with three plates. This memoir was read before the Royal Swedish Academy in February 1874, and describes the two specimens as two species, under the names of *U. miniacea* and *U. pallida*. Prof. Kolliker has also described one of the species found during the *Challenger* expedition as *U. Thomsoni*, making four species of the genus now described. It is marvellous what changes have taken place in our knowledge of the Natural Sciences in the interval between the description of Ellis's species and those so excellently described and figured in the memoir before us. The other genus *Grinillum* of the family *Umbellulinae*, found about 1858 in a depth of 2,700 fathoms in the Banka Sea, will, we trust, be re-discovered by Prof. Wyville Thomson. It is only known by a fragment of the stem in the Leyden Museum, the crown of polyps having fallen overboard as Capt. Siedenburgh, after whom the species is called, was pulling in the line to which it clung.

E. P. W.

## SCIENCE IN THE ARGENTINE REPUBLIC\*

THE Bulletin of the National Academy of Exact Sciences of Cordova, of which the three first numbers have lately reached this country, gives us an interesting account of a new endeavour of the well-known naturalist, Dr. Burmeister, to introduce scientific studies into his adopted country. In 1868 Dr. Burmeister presented a memorandum to Dr. Sarmiento, lately President of the Argentine Republic, upon the expediency of adding a Faculty of Mathematical and Physical Sciences to the National University of San Carlos in Cordova. In response to this appeal authority was given to Dr. Burmeister by the Minister of Public Instruction to import eight professors from Germany to establish the Faculty; and Dr. Burmeister himself was appointed Special Commissioner for the purpose, and eventually Director of this branch of the University. For a long time, Dr. Burmeister

tells us, his exertions to obtain a staff of professors from his old colleagues in Halle were unsuccessful. The novelty of the idea and the distance of Buenos Ayres rather stood in the way of his offers being accepted. At length, in 1870, two of the vacant posts were filled by the arrival of Dr. Max Siewert to occupy the chair of Chemistry, and of Dr. P. G. Lorentz to fill that of Botany. In the following year the assistance of Dr. G. H. Weyenbergh, of Haarlem, was obtained for the chair of Zoology, and that of Dr. Sellack for the professorship of Medicine. Not until 1873 was the staff finally completed by the appointment of Dr. Vogler to the professorship of Mathematics. In the same year, as we understand from Dr. Burmeister's report, the plans for the construction of the new buildings necessary for the University were finally approved of by the National Congress, and the works are now in process of execution.

From notices which subsequently appear in the *Bulletin* we fear that Dr. Burmeister has met with some difficulties in controlling his staff of professors. This can be hardly wondered at when the novelty of the plan is considered, and the difficulty of getting eight persons, strangers to each other, to work together to establish a new institution in a far distant country, where a foreign tongue is spoken. We have little doubt, however, that under Dr. Burmeister's supervision all will ultimately right itself, and that the Academy of Exact Sciences of Cordova will become an institution highly creditable to the enlightened rulers of the Argentine Republic, who have established the National Observatory under the direction of the distinguished astronomer Dr. Gould in the same city.

That some progress has already been made in the cultivation of the natural sciences in Cordova is apparent by several papers contributed to the first three numbers of the *Bulletin*, amongst which are essays "On the Land and Fresh-water Molluscs," by Dr. Dööring; "On certain genera of Microlepidoptera," by Dr. Berg; "On the Vegetation of the province of Tucuman," by Dr. Hieronymus; and "On the Salinas of Buenos Ayres," by Dr. Schickendaut.

## NOTES

AT the suggestion of the Council of the Royal Geographical Society, a manual will be prepared for the use of the Arctic Expedition, consisting of reprints of papers in the transactions of learned societies which would not otherwise be accessible, and other materials; the object being to furnish an exact view of the state of existing knowledge of Greenland and the surrounding seas. The geographical and ethnological portions will be undertaken by the Arctic Committee of the Geographical Society. The other sections will be edited by Mr. Rupert Jones, under the supervision of a Committee of the Royal Society. The appointments of the lieutenants and other officers to the Arctic Expedition were made this week. The Royal Society has recommended the appointment of a botanist and a zoologist for the consideration of the Admiralty, but they have not yet been officially selected. Good progress is being made in the strengthening of the ships at Portsmouth, which have been ordered to be ready for sea by the middle of May. The statement, in some of our contemporaries, that Capt. E. Ilobart Seymour is to be second in command of the Expedition, is incorrect.

MANY sorts and conditions of men will regret as a personal loss the death of the Rev. Charles Kingsley, which took place on Saturday last. We regret his loss as that of a man who had a warm love for science, and who by his writings and example has done much to foster a love for it among others. He was an honour to his country and his cloth, and it would be a good thing for the latter in many ways if its members could be persuaded to follow his example, and, like him, take a hearty

\* Boletín de la Academia Nacional de Ciencias Exactas existente en la Universidad de Cordova. Entregas 1, 2, and 3. Buenos Aires, 1874.

interest in every healthy form of human activity. Few men have been more loved than Charles Kingsley, and the wide influence of his example and teaching has been undoubtedly for good.

THE death is announced of M. d'Omalius d'Halloy, the well-known veteran Belgian geologist, as having taken place on the 15th inst., at the age of ninety-two years. M. d'Halloy was born at Liège on February 16, 1783. He was a member of the Royal Academy of Brussels, of which he was president in 1850, Corresponding Member of the French Academy of Science, and Member of the Geological Society of Paris. He was author of a large number of scientific works; among others, "Éléments de Géologie" (1831), "Introduction à la Géologie" (1833), "Précis élémentaire de Géologie" (1843), "Abrégé de Géologie" (1853), besides numerous memoirs in the *Journal des Mines*, the *Journal de Physique*, the *Annales des Mines*, the *Mémoires* of the French Geological Society, and the *Bulletin* of the Belgian Academy.

WITH regard to the Transit of Venus, the following telegram, dated Aden, Jan. 21, has been received:—"Ingress and egress well observed from three stations in Rodrigues; nine Janssen plates; fifty-eight sun-pictures. Observers, Neate, Hoggan, Wharton."

A GENTLEMAN whose name is unknown has made a gift of 10,000*l.* for the promotion of university education among the working classes of Nottingham.

AT the recent meeting of Convocation of the University of London, a resolution was unanimously carried, "That in the opinion of Convocation it is desirable that a special examination be instituted in this University in the subjects which relate to public health." It was stated that there is every probability of the Senate giving force to the resolution by the establishment of an examination of the character indicated.

A COURSE of six lectures on scientific subjects, in the Town Hall, Stratford, was commenced on Monday by Mr. J. Norman Lockyer, F.R.S., whose subject was the "General Principles of Spectrum Analysis." The hall, we believe, was crowded with an attentive and intelligent audience, largely composed, apparently, of people belonging to the working classes. Mr. Lockyer lectures on the same subject next Monday, and on the two succeeding Mondays Dr. Martin Duncan, F.R.S., lectures on "Mountain-making" and on "Coral Islands." On Mondays, March 1 and 8, Dr. Carpenter, F.R.S., will lecture on "Deep-sea Researches." The lectures are given in connection with the Gilchrist Educational Trust.

THE Council of the Royal Horticultural Society have recently instituted a series of fortnightly lectures on Wednesday evenings, at eight o'clock, intended especially for those Fellows and their friends whose engagements prevent their attendance at the Wednesday afternoon meetings, and for the instruction of their gardeners. The first lecture of the series was delivered by Prof. Dyer, on the Growth of Ferns from Spores, which was followed by one last evening by Mr. A. W. Bennett, on the Fertilisation of Flowers by means of Insects.

FEW papers of greater interest to botanical students have recently issued from the press than Mr. Bentham's treatise on the recent progress of systematic botany, read at the Belfast meeting of the British Association, and which, but for untoward circumstances, would have formed the address to the Linnean Society at the Anniversary Meeting in May last. Commencing with a review of the history of systematic botany from the time of Linnæus, and of the gradual introduction of the natural system, he then considers the principal works in this branch of science recently published, or now in progress, under the follow-

ing heads:—(1) *Ordines Plantarum*, or general expositions of the orders and sub-orders constituting the vegetable kingdom; (2) *Genera Plantarum*, or systematic descriptions of all the genera constituting the vegetable kingdom; (3) *Species Plantarum*, or systematic enumeration and descriptions of all known species; (4) Monographs of orders and genera; (5) Floras, or histories of the plants of particular countries or districts; and (6) Specific descriptions, detailed or miscellaneous. The practical advice of this veteran systematist to compilers of works of this description should be carefully studied by all botanical writers.

A NEW French weekly scientific periodical has issued its first number under the patronage of a Standing Committee of the French Geographical Society. It is edited by M. Herz, one of the staff of the *Journal Officiel*. It is called the *Explorateur*, and is published for the purpose of promoting the cause of geographical exploration among the French. One of its first objects is to send trustworthy travellers into the Sahara, where M. Dourneau-Dupré and others were murdered a few months ago. The *Explorateur* is opening, at present, a private subscription on behalf of M. Largeau, who is desirous of trying his chances in the same region. Some native pioneers have been also sent out, and are expected shortly to transmit valuable intelligence from the central Sahara.

A PARCEL of dried plants has recently been received at Kew from the Samoan Islands, sent by the Rev. Mr. Powell. Some novelties may be expected from this region, as it is still very little explored.

PROF. DYER's article on the Tree Aloes of South Africa, recently published in this journal, having elicited numerous inquiries respecting this curious genus, it may be interesting to some of our readers to know that several fine species are in flower at the present time in the Succulent House at Kew.

TREE FERNS are nearly all of elegant and pleasing habit, and one deserving those epithets in a high degree is *Cyathea insignis*, a native of Jamaica and other West Indian islands. A magnificent specimen of this species recently attracted admiration in the tropical conservatory at Kew. It has fronds upwards of twelve feet in length, the stipes or stalks of which are densely clothed with long glossy scales.

ABOUT fifty new genera were added to the flora of Australia during the year ending with the appearance of Baron Mueller's last report, many of them of great interest in phytogeography. The following are a few of the more interesting:—*Corynocarpus*, *Carmichaelia*, *Ilex*, *Lagerstroemia*, *Agrimonia*, *Embothrium* (§ *Oreocallis*), *Ulmus* (§ *Microptelea*), *Morrea*, *Areca*, and *Wolfia*.

PASSING through the greenhouse containing the collection of succulent plants at Kew the other day, a correspondent was much struck with the flowers of a plant he had previously taken to be an ivy. The resemblance in foliage and habit is indeed so strong that a botanist might easily mistake it for a species of that genus, unless, of course, it was minutely examined. It is a native of South Africa, and is referred to the familiar genus *Senecio*, *S. macroglossus* being its name. The yellow flower-heads are large and showy, the ray-florets being few and broad. A figure of it, we are informed, will shortly be published in the *Botanical Magazine*. This plant has been introduced into St. Helena, where it bears the name of Ground Ivy, as may be learned from the label attached to a specimen in the Kew Herbarium, sent from thence by Mr. Melliss. Several other South African species of the same genus present equally interesting peculiarities.

BOXWOOD, the wood of *Buxus sempervirens*, which is almost exclusively used for the best kinds of wood-engraving, has been

for some years becoming more and more scarce. Wood of the largest diameter is the produce of the forests of the countries bordering on the Black Sea. Large quantities are produced in the neighbourhood of Poti, from which port the wood is shipped direct to England. The supply, however, from this port is, we learn, becoming fast exhausted; and it is said, unless the forests of Abkhassia are opened to the trade, it must soon cease altogether. The quantity exported from Poti during the year 1873 amounted to 2,897 tons, of the value of 20,621*l.*; besides this, from 5,000 to 7,000 tons of the finest quality annually pass through Constantinople, being brought from Southern Russia and from some of the Turkish ports of the Black Sea for shipment, chiefly to Liverpool. An inferior and smaller kind of wood supplied from the neighbourhood of Samsoon is also shipped at Constantinople to the extent of about 1,500 tons annually. With regard to the boxwood forests of Turkey, the British Consul at Constantinople reports that they are nearly exhausted and that very little really good wood can now be obtained from them; in Russia, however, where some little Government care has been bestowed upon forestry, a considerable quantity of choice wood still exists; but even there it can only be obtained at an ever-increasing cost, as the forests near the sea have been denuded of their best trees. The trade is now entirely in English hands, although formerly Greek merchants exclusively exported the wood. In the province of Trebizonde the wood is generally of an inferior quality; nevertheless, from 25,000 to 30,000 cwts. are annually shipped, chiefly to the United Kingdom.

THE trade between Portugal and Great Britain is very largely composed of fruits of the Citrus tribe: the value of the exports from Portugal have, however, of late been considerably augmented, and will be more so in a few years, by the large number of pine-apples shipped to England. During the last two or three years the cultivation of this fruit in the Azores for export purposes has been largely developed. Bananas, also, have occupied much attention, and have been exported in such quantities, and realized such remunerative prices, that a large and flourishing trade may be expected. With these products already established and yielding satisfactory returns, it would scarcely be supposed that landowners would devote their attention to other and untried crops; yet we learn that the *Phoenixium tenax*, or New Zealand flax plant, has been introduced into some parts of the Azores, where its growth has proved highly satisfactory: and as it is proved that they flourish in places where nothing else will grow, it may, in course of time, become an article of export.

THE distillation and manufacture of attar of rose is a large and important branch of industry in Adrianople. In the northern parts of the country, we are told in an official document, the produce of 1873 exceeded by 35 per cent. that of the previous year, the quantity distilled being some 121,875 ounces, valued at about 90,000*l.* It is chiefly exported from Philippopoli to England, France, Germany, and Austria; and recently merchants in the United States and Germany have opened correspondence with firms in Adrianople, with the view of establishing agencies to further extend this branch of commerce.

A VALUABLE and interesting report reaches us from New Zealand, on the "Durability of New Zealand Timbers." It has been drawn up by Mr. T. Kirk, F.L.S., and is by far the best account of the woods of that colony that we are acquainted with. New Zealand has exhibited her timbers at several of the international exhibitions; and though many of them have been remarkable both for size and beauty, they have never rivalled those of our Australian colonies, owing to want of care in seasoning, preparing, and naming the specimens. In some practical hints on seasoning timber, Mr. Kirk rightly says that no plan is so effective as keeping it in well-ventilated sheds, protected from the

rain. He points out errors in felling and using timber, which all practical foresters and builders are acquainted with, but which are unfortunately of too frequent occurrence in many countries, namely, felling trees during the growing season, using timber immediately after felling, coating green or unseasoned wood with paint, &c. In the list of useful woods given, which number thirty-eight distinct trees, the Kauri (*Dammar australis*), Totara (*Podocarpus totara*), and the Red Pine, or Rimu (*Dacrydium cupressinum*) have a first place. The first-named is the finest tree in New Zealand, growing to a height of 120 to 160 feet; its wood, also, is the most valuable, being used before all others for masts, spars, and other shipbuilding purposes. The wood is frequently very beautifully mottled, and would be much valued by cabinet-makers in this country, were it an article of import; but New Zealand woods reach us only occasionally. The Kauri is largely used in New Zealand for railway sleepers. As an instance of its durability, Mr. Kirk says that near Papakura, an ancient Kauri forest has been buried at some remote period; in some places the logs still show above the surface. Much of the timber has been dug up in perfectly sound condition, and used for sleepers on the Auckland and Waikato Railway. Kauri timber is also exported to some extent from New Zealand to Australia, Tasmania, and Mauritius; and during the past three years the quantity so exported has more than doubled. Considering the limited area to which the tree is confined, it is to be hoped that some system of conservancy will preserve the trees.

THE Senatus of Edinburgh University has received a favourable reply from the Treasury as to an endowment for the proposed Chair of Education. Dr. Bell's trustees offered an endowment of 4,000*l.*, and the Senatus asked Government to grant a similar sum to complete the endowment. It is also stated that the arrangements for the establishment of the Chair of Education in the University of St. Andrew's are in such a state of forwardness that it is expected they will be completed forthwith, and that a Professor, with a suitable endowment, will be ready to enter on his duties by the beginning of next winter session.

THE Council of the Society of Arts have decided to offer the Society's Fothergill Gold Medal for an effective means of extinguishing fire on board ship, and they have directed the Secretary to enter into communication with leading shipowners, with the view of enlisting their aid in this important matter.

AN underground railway was inaugurated between Pera and Galata a few days since.

THE meeting at Paris of the International Conference on the Metrical System has been postponed till March 1.

ON the morning of January 22 an earthquake was felt at Ravenna, in Central Italy. The exact hour is not stated. It would be curious to ascertain whether it was connected with the rapid elevation of barometrical pressure of 17 millimetres in a few hours, which was observed at the Paris Observatory and in many other places in France at the same time.

AT a recent meeting of the Academy of Natural Sciences of Philadelphia, Prof. Leidy—from a study of some fresh specimens sent him by Prof. Hayden, and obtained about one hundred miles east of Greeley, Colorado—declared his conviction that the colossal genus *Brontotherium* of Marsh is synonymous with *Symborodon* and *Miobasilens* of Cope; and that all these must give place to *Titanotherium* of Leidy, of which there are probably not more than two species.

MR. S. W. GARMAN describes, in the Proceedings of the Boston Society of Natural History, a new American species of serpent from Florida, under the name of *Helicops alleni*.

MR. WILCOX communicates to the Academy of Natural Sciences of Philadelphia the account of an unusual mode of

burial which was formerly practised among the Indians of North Carolina. He states that in numerous instances burial-places have been discovered where the bodies had been laid with the face up and covered with a coating of plastic clay about an inch thick. A pile of wood was then placed on top and fired, consuming the body and baking the clay, which retained the impression of the body. This was then lightly covered with earth.

INTERESTING additions to our knowledge of the fauna of the Mammoth Cave have recently been made by Mr. F. W. Putnam, of Salem, U.S., who, as a special assistant on the Kentucky State Geological Survey, of which Prof. N. S. Shaler is the director, had great facilities extended by the proprietors of the cave, and he made a most thorough examination of its fauna, especially in relation to the aquatic animals. Mr. Putnam passed ten days in the cave, and by various contrivances succeeded in obtaining large collections. He was particularly fortunate in catching five specimens of a fish of which only one small individual had heretofore been known, and that was obtained several years ago from a well in Lebanon, Tennessee. This fish, which Mr. Putnam had previously described from the Lebanon specimen under the name of *Chologaster agassizii*, is very different in its habits from the blind fishes of the cave and other subterranean streams, and is of a dark colour. It lives principally on the bottom, and is exceedingly quick in its motions. It belongs to the same family as the two species of blind fishes found in the cave. He also obtained five specimens of four species of fishes that were in every respect identical with those of the Green River, showing that the river fish do at times enter the dark waters of the cave, and when once there apparently thrive as well as the regular inhabitants. A large number of the white blind fishes were also procured from the Mammoth Cave and from other subterranean streams. In one stream the blind fishes were found in such a position as to show that they could go into daylight if they chose, while the fact of finding the *Chologaster* in the waters of the Mammoth Cave, where all is utter darkness, shows that animals with eyes flourish there, and is another proof that colour is not dependent on light. Mr. Putnam found the same array of facts in regard to the crayfish of the cave, one species being white and blind, while another species had large black eyes, and was of various shades of a brown colour. A number of living specimens of all the above-mentioned inhabitants of the waters of the cave were successfully brought to Massachusetts after having been kept in daylight for several weeks, proving that all the blind cave animals do not die on being exposed to light, as has been stated.

WE have received the *Annuaire* of the Belgian Academy for 1875. It contains the usual useful information concerning the organisation and work of the Society, the prizes it awards, list of members, &c. The principal memoir is that of Quetelet, mentioned in NATURE, vol. xi. p. 217, with a portrait; there are also memoirs, with portraits, of two other deceased members, Charles Poelman, the comparative anatomist, and H. L. F. Partoes, the architect.

THE additions to the Zoological Society's Gardens during the past week include an Australian Cassowary (*Casuarus australis*), new to the collection, from Australia, presented by the Marquis of Normanby; a Banded Cotinga (*Cotinga bincta*) and a Naked-throated Bell-Bird (*Chasmerhyuchus nudicollis*), from Bahia, purchased; a King Vulture (*Gyparchus papa*) from Buenos Ayres, presented by Mr. M. Billingham; a Bonnet Monkey (*Macacus radiatus*) and a Macaque Monkey (*M. cynomolgus*), presented by Mr. H. Lumsden, a Rhesus Monkey (*M. erythroceus*), presented by Mr. W. de Winton, and a Bonnet Monkey, presented by Miss M. Hailes, all from India; a Black-tailed Antelope (*Nanotragus nigricaudatus*) from West Africa, purchased.

## ON THE MUSCULAR MECHANICAL WORK DONE BEFORE EXHAUSTION

MUSCULAR exertion may be either dynamical or statical. Dynamical work is generally intermittent, while statical work is generally continuous in its action. The dynamical work done by any muscle before exhaustion is easily measured in kilogrammetres. Assuming the force exerted by any muscle to be  $w$ , and if  $n$  be the number of times the force is exerted through the distance  $h$ , until exhaustion sets in, then the total work,  $W$ , done before exhaustion, is

$$W = w h n \quad (1).$$

If, however, a weight,  $w$ , be supported on the horizontally outstretched arm, then by the above formula the amount of work is zero, although the arm soon tires out. In his "Principles of Animal Mechanics" pp. 24-44, London, 1873, Mr. Haughton has attempted to estimate the statical work thus done by the muscles of the arm. Let  $w$  = the weight,  $a$  = weight of arm,  $a$  = distance from centre of glenoid cavity to centre of weight, and  $t$  = time in seconds before exhaustion. The muscles exert a force capable of sustaining the weight of the loaded arm at its centre of gravity. Let  $\theta$  be a small arc, through which the arm moves uniformly with an unknown angular velocity  $w$  in the time  $t$ . Then, if  $x$  is the distance from the centre of the glenoid cavity to the centre of gravity of the loaded arm, we have—

$$\text{Total work} = (w + a) x \theta$$

But since

$$(w + a) x = a \left( w + \frac{a}{2} \right),$$

and

$$\theta = w t, \quad \text{we shall have—}$$

$$\text{Total work} = w a \left( w + \frac{a}{2} \right) t \quad (2).$$

The values of  $(a)$  and  $(a)$  are easily obtained by direct measurement and calculation. This formula (2) is, however, no better than (1), for when  $\theta$  is zero,  $w$  is also zero, and the work would be nothing. Mr. Haughton has, however, used this formula, assuming  $w = 1$ , which value he has deduced from experiments made by myself (Prin. of Animal Mech., pp. 475-7), and published in the *School Laboratory*, 1871, vol. i. p. 108. The experiments were conducted as follows:—

A weight  $w = 700$  kilos, was lifted from a vertical to a horizontal with the shoulder, in a varying time  $t$ . At the instant the weight reached the horizontal, the muscles were relaxed, and the weight allowed to drop, being caught on a cushion attached to the leg. The intervals of work and rest,  $t$ , were in all cases equal. (I intend to repeat these experiments, making the interval of rest constant). Mr. Haughton has repeated my experiments, and has deduced the formula—

$$n = \frac{A t}{1 + \left( \frac{2 w}{\pi} \right)^2 t^2} \quad (3).$$

where  $n$  is the number of lifts before exhaustion. The observations for my right arm are given below.

TABLE I.

$t$	$n$ (obs.)	$n$ (calc.)	$d$ per cent.	$e$ per cent.
1'164	15'8	22'2	- 41	1'9
1'50	22'8	22'8	0	2'1
2'00	18'5	21'7	- 17	1'0
3'00	17'3	18'2	- 5	1'7
4'00	15'3	15'3	- 1	1'9
4'50	15'0	13'8	+ 8	1'3
5'00	14'3	12'6	+ 12	2'8
6'00	12'8	9'4	+ 27	3'1

The values of the constants in (3) as obtained by Mr. Haughton are,  $A = 30'4$  and  $\frac{2 w}{\pi} = 0'666$ . Substituting these values, and the proper values of  $t$  in (3), and we have  $n$  (calc). Column  $d$  is the difference in per cent. of  $n$  (obs.). Each value of  $n$  obs. is a mean of four determinations. The probable error of this mean in per cent. of  $n$  (obs.) is given in column  $e$ . The experi-

\* These experiments were merely published as a preliminary, in order that I might pursue the investigation at my leisure.

ments of Prof. Haughton are more nearly represented by (3), but that they are in themselves more accurate, is, as will be seen, a matter of doubt. One of the deductions which Prof. Haughton makes from (3) is the determination of his so-called "angular velocity,"  $w = 0.666 \frac{\pi}{3} = 1.0472$ .<sup>\*</sup> The mean value of  $w$  as determined from several observations is 1.00. Hence (2) becomes—

$$\text{Total work} = a \left( w + \frac{a}{2} \right) t. \quad (4).$$

Besides the difficulties already noticed, the conclusion arrived at in (4) is open to several fatal objections, a few of which I will detail.

1. In his reduction resulting in (3), Prof. Haughton assumes the truth of the following law (Prin. An. Mech., p. 442):—"When the same muscle (or group of muscles) is kept in constant action until fatigue sets in, the total work done, multiplied by the rate of work, is constant." By "rate of work" is meant the work per second. But in these experiments the muscles were not "kept in constant action," and even during the interval of work the action of the muscle constantly varies. The "rate of work" is therefore also entirely indefinite.

2. The method of experiment used by me, and which seems to have been followed by Prof. Haughton, I have found entirely unreliable, as will be hereafter shown.

3. Putting  $\beta = \left( \frac{2\omega}{\pi} \right)^2$  in (3) and it may be reduced to the form—

$$\frac{n}{t} = A - \beta n t \quad (3').$$

Anyone who will take the trouble to calculate aid co-ordinate the values  $\frac{n}{t}$  and  $nt$  from Prof. Haughton's observations, pp. 468, 474, will see that these co-ordinated values form a curve, instead of a straight line. This is much more plainly marked in an unpublished series now in my possession. These latter experiments were made with an apparatus and method to be described in the next paper. They are more accurate than those before published, but not as accurate as can be obtained. It is certain, however, that the value of  $w$  in (3) is not constant. Assuming it to be constant, however, and its value in the series referred to, lies between 0.30 and 0.50. This illustrates very forcibly the futility of attempting theoretical reductions on the basis of assumed "laws," until we have first made sure of our facts.

Another series of mine which was also reduced by Prof. Haughton consisted in raising a varying weight,  $w$ , through the length of the arm in a time  $t = 1.164$  sec. The experiments were otherwise conducted as before described. Mr. Haughton makes use of the above-quoted law in this reduction, and finds the relation to be—

$$\left( w + \frac{a}{2} \right) n = \frac{A'}{\left( w + \frac{a}{2} \right)} \quad (5).$$

For my right arm the constants are  $A' = 1000$  and  $a = 2.0$ . The comparison of  $n$  (calc.) and  $n$  (obs.) is satisfactory, and for want of space it is omitted. Solving (5) for  $n$  and making  $w = 7.0$ , and making  $t = 1.164$  in (3), and the values of  $n$  are evidently identical, or—

$$Z \frac{A'}{(7.0 + 1)^2} = \frac{A' 1.164}{1 + \left( \frac{2\omega}{\pi} \right)^2 (1.164)^2}$$

where  $Z$  should equal unity. Solving for  $Z$  and introducing the values of the constants, and we find  $Z = 1.41$ . Although this discrepancy was pointed out to him, Prof. Haughton has transferred unreduced, from the observations leading to (5), the first value of  $n$  ( $t = 1.164$ ) in Table I. It is to be regretted that Prof. Haughton did not leave unpublished the last 43 pages of his interesting and valuable work. FRANK E. NIPHER.

(To be continued.)

### SCIENTIFIC SERIALS

The current number of the *Journal of Anatomy and Physiology* commences with a suggestive description, by Dr. J. F. Goodhart, of three cases of malformation of the spinal column

\* A few of these decimals might be dropped without impairing the accuracy of the result.

associated with lateral curvature, which lead him to the conclusion that cases of asymmetry of the two sides of the spinal column are due to original malformation of the bodies of the implicated vertebrae in the direction of a bi-lobed or double nucleus, and the subsequent unequal growth of the two halves. —Prof. Struthers has also a lengthy article on variations of the vertebrae and ribs in man, which will be read with interest in connection with that of Dr. Goodhart, and by all comparative anatomists, several very instructive abnormalities being described. —This paper is followed by one from the pen of Dean Byrne, on the development of the powers of thought in vertebrate animals in connection with the development of their brain; in which the author, by a comparison of the cerebral capacities of the different families of Mammalia with those of comparative anatomical structure and embryonic development, endeavours to prove that the functions of the anterior lobes of the brain belong to the act of thinking single objects of sense, those of the middle lobes to the act of thinking such objects with a sense of succession of them and as part of that succession, and those of the posterior lobes to the act of thinking a co-existence or succession of them as a case of a general principle. —Prof. M. Watson continues his contributions to the anatomy of the Indian elephant, describing the muscles and blood-vessels of the face and head. The same author also, with a drawing, describes a remarkable case of pharyngeal diverticulum, which opened on the free margin of the posterior pillar of the fauces, occupied the anterior triangle of the neck, and had a duct-like communication with its orifice, running between the internal and external carotids. —Dr. Arthur Ransome records the position of the heart's impulse in different postures of the body, from chest-rule measurements made by Mr. W. A. Patchett.—Baron A. de Watteville describes the cerebral and spinal nerves of *Rana esculenta*, from a series of dissections recently made. —Prof. Turner gives an account of the occurrence of *Phoca greenlandica* as a British species, from a specimen captured in Morecambe Bay and identified by Mr. T. Gough. —Mr. J. C. Ewart records notes on the minute structure of the retina and vitreous humour. —Mr. J. C. Galton also has a note on the Epitrochleo-anconeus or Anconeus Sextus (Gruber) as a supplement to Prof. Gruber's paper, giving drawings of it in *Tamandua tetradactyla*, *Choloepus didactylus*, *Plascolonyx wombata*, and *Echidna setosa*. —The remaining short papers are by Mr. J. Reoch, on urinary pigments; by Dr. J. J. Charter, on abnormalities of the arteries of the upper extremity; by Mr. J. Harker, on a four-toed foetus without head or upper limbs; and by Dr. J. Cantlie and Mr. Bellamy, on the absence of the quadriceps-femoris muscle, and on the presence of a sixth lumbar vertebra, the first rib being rudimentary.

The *Scottish Naturalist* for January maintains the prestige of this interesting quarterly, now entered on its fifth year and third volume. It commences with an article of a more popular character than most—"Illustrations of Animal Reason," by Dr. Lauder Lindsay, the authenticity of the anecdotes being vouched for by the writer. Among the botanical notes, the most interesting is that of the discovery in Aberdeenshire by Mr. Sadler, during an excursion of the "Scottish Alpine Club," of two plants new to Britain, *Carex frigida* and *Salix Sadleri*, the latter now described for the first time, and probably a hybrid between *S. reticulata* and *S. leppomum* or *lanata*. We have further instalments of "The Lepidoptera of Scotland," by Dr. Buchanan White, and "The Coleoptera of Scotland," by Dr. Sharp.

*Poggendorff's Annalen der Physik und Chemie*, 1874, No. 11. —The first paper is by W. Müller, of Perleberg, on the reduction of metallic oxides by hydrogen, and the application of this process for the quantitative determination of metals. The value of this method of quantitative determination depends on the fact that hydrogen reduces different metallic oxides at different temperatures. The results of Müller's experiments show that the quantities of several metallic oxides may be determined in this way, when the mixtures are heated in hydrogen, and care is taken with regard to regulation of temperature. The method proved successful for copper and zinc, copper and silver, copper and bismuth, copper and cadmium, copper and lead, copper and tin, copper and iron; also for copper, iron, and zinc, and pretty well for copper, cadmium, and zinc; but it was unsuccessful in the case of silver and iron, silver and lead, arsenic and antimony. The apparatus is simple enough, but the experiments take a very long time, and will not be of much general practical use.—The next paper records some thermo-electric studies by E. Budde.—Dr. Kurd

Lasswitz, of Breslau, contributes an article on the decay of the "kinetic atomic theory" in the seventeenth century.—On torsion communication is by Dr. H. Streintz, of Vienna, on torsion-oscillations of wires. It is followed by a paper on resistance in galvanic conductors, by H. Herwig. This paper was accidentally delayed, and should have been published before another one on the same subject, which appeared in Part 1874, No. 9, of these Annals.—The next paper, on fluorescence, by O. Lubarsch, is highly interesting. The author gives an account of elaborate investigations he made on the subject, with special reference to spectrum analysis; his general results seem to show (1) that for each fluorescent substance there are only certain rays of light causing fluorescence; (2) that the colour of the fluorescent light depends on the rays of incidence, and follows Stokes's law; and (3) that the most refrangible fluorescent rays, produced by sunlight, correspond to that place in the spectrum where the liquid shows its maximum of absorption, providing its fluorescence proves a simple one, when examined by prismatic analysis of the linear spectrum. In all three points Mr. Lubarsch differs from Pierre and Lommel, who investigated the subject before him.—On the expansion of mercury after Mr. Regnault's experiments, is a valuable communication from Mr. A. Willner.—The remaining papers are: On the influence of the temperature of air on the index of refraction, by M. V. von Lang; and on the oblique passage of rays through lenses with reference to a peculiarity of the crystalline lens, by L. Herman.—Besides these, there is a short note by H. Schuebeli, on Hipp's machine for determining the laws of motion.

*Der Naturforscher* (Nos. 49-52, Dec. 1874).—Among the papers in this number we note the following:—On currents and temperatures in the Atlantic Ocean; observations made on board the German corvette *Gastell*, by the commander Herr von Schleinitz, on a voyage to the Kerguelen Islands.—On carnivorous plants; researches made by Prof. Ferd. Cohn, of Breslau, with European species.—Note on the discovery of a new asteroid, 139, on Oct. 13, 1874, by Mr. J. Palisa, at Pola. It appeared of the 11th magnitude, under R.A. 2h. 7m. 19'39s.; Decl.  $+7^{\circ} 29' 50''$ .—On the native iron of Oviak, Greenland; discussing the question whether this native iron is of meteoric or terrestrial origin.—On the influence of temperature upon the respiration of plants; researches made by Herren von Wolkoff and Mayer at Heidelberg, showing that the influence is not nearly so great as is generally accepted.—On the formation of urea in the animal organism, by Herr von Knierim.—On attraction and repulsion by heat and light, by A. Bergner; account of experiments made, which led to different results than those obtained by Mr. Crookes.—On the decrease of intensity in the light of Jupiter's satellites when passing over the planet's disc. This was explained by S. Alexander as resulting from interference and absorption of the rays of light; H. J. Klein now gives a much simpler explanation.—On the inorganic cell and the phenomena of growth in the inorganic world, by M. Traube; giving a purely physical explanation for the origin and growth of the cell.—Besides many smaller notes of scientific interest, the last number contains a detailed account of the sledge journeys made by Oberlieutenant Jul. Payer while in polar regions with the Austrian Polar Expedition.

## SOCIETIES AND ACADEMIES

### LONDON

Royal Society, Jan. 21.—"On the Origin and Mechanism of Production of the Prismatic (or columnar) Structure of Basalt," by Robert Mallet, C.E., F.R.S., &c.

In this paper the author shows that all the salient phenomena of prismatic basalt as observed in nature can be accounted for as results of contraction by cooling in a homogeneous body possessing the properties of basalt, and that the theories hitherto advanced and repeated in text-books of the production of basaltic prisms are alike untenable and unnecessary. If a large level and tabular mass of homogeneous basalt cool slowly by loss of heat from one or more of its surfaces, the contraction of the mass while plastic will be met by internal movements of its particles; but when the temperature has fallen to a certain point of rigidity reached at between  $900^{\circ}$  and  $600^{\circ}$  F., splitting up commences, and that surface will begin to divide itself into similar geometric figures of equal area, which on mechanical principles must be hexagons, the diameter of which is shown to depend upon the relation that subsists between the

coefficients of extensibility of the material and of its contraction by cooling down to the splitting temperature. These hexagons are the first formed ends of the future prisms, which split deeper into the mass as cooling down to the splitting temperature reaches deeper into it. When the prisms have split down to a certain distance, further cooling proceeds, not only from the ends of the prisms, which formed the surface of original cooling, but from the sides of the prisms. Now, as each prism is coldest at the end, and hottest where in the act of splitting, and is also hotter along the axis than at the exterior of each prism, so, by contraction, differential strains are produced in each prism, both parallel to the axis and transverse to it, which result in cross fractures at intervals along the length of the prism, the distances between which the author has assigned. Transverse fracture round the prism must commence in the outer *couche* in a plane normal to the resultant of the contractile strains longitudinal to and transverse to the axis of the prism; the fracture commences, therefore, oblique to the prismatic axis. This obliquity diminishes as the transverse contractile force diminishes, as the circumferential *couche* of cooling reaches nearer to the axis of the prism; and the result is that the transverse fracture when completed is lenticular or cup-shaped, the convex surface always pointing in the same direction in which the cooling is progressing within the mass.

If the mass cool from the top surface only, the convex surfaces of the cup-shaped joints will all point downwards; if cooled from the bottom only, they will point upwards; and if from both surfaces, the convexity of the joints will be found pointing both upwards and downwards in the mass. As the splitting always takes place normal to the surface of cooling, so, if that surface be level and cool, uniformly, the prisms must be vertical and straight; also, if the cooling surface be a vertical or inclined one, the direction of the prisms will be normal thereto. If, however, the mass cool from its upper or lower surface, but of much greater thickness in one direction than in the opposite one, the prisms formed will not be straight, but have their axes curved, because the successive *couches* reaching the splitting temperature successively within the mass, and normal to which the splitting takes place, are themselves curved planes. These are a few of the principal points of this paper, which the author believes renders, for the first time, a complete and consistent account of all the phenomena observed in prismatic basalt. A considerable number of these phenomena were referred to and explained by the author. At the conclusion of his paper the author submits to rigid examination the notions which from 1804, the period of Mr. Gregory Watts's paper (Phil. Trans.), to the present time, have continued to occupy the text-books of geologists, and he points out how entirely these fail to account for the phenomena.

Linnean Society, Jan. 21.—Dr. G. J. Allman, F.R.S., president, in the chair.—Dr. Hollis read a paper on the pathology of oak-galls. Oak-galls may be divided into two classes, the unilocular or one-celled, which include the woody marbled oak-galls, the ligneous galls of Réaumur, and the currant leaf-galls; and the multilocular or many-celled, including the spongy oak-apple and the oak-spangles of the leaves. The author went with some detail into the structure and history of development of each of these kinds, taking a few examples of each. With the exception of the oak-spangles, all the different kinds appear to be formed during the growth of the leaf. The pathological differs from the healthy development in the more rapid growth of its cellular elements and in the larger size they attain; this is gained at the expense of the differentiation of the matrix of the bud. The author traced the origin of the different layers of the gall itself to the different layers of the leaf from which it is produced. A discussion followed, in which the President, Mr. Murray, Mr. Howard, Prof. Dyer, and others took part.—The following papers were then read:—Reports of the *Challenger* Expedition; On the Lichens, chiefly of Tristan d'Acunha, by the Rev. Dr. Stirton.—On the Lichen Flora of New Zealand and Chatham Island, by the Rev. Dr. Stirton.

Mathematical Society, Jan. 14.—Prof. H. J. S. Smith, F.R.S., president, in the chair.—Mr. J. W. L. Glaisher gave an abstract of a paper by Prof. Cayley, on the potentials of ellipses and circles. The potential of an ellipse of uniform density (in regard to a point not in the plane of the ellipse) was found by a process similar to that made use of in Gauss's memoir, "Determinatio attractionis quam exerceret Planeta," &c. (1818); the final result resembled in a remarkable manner the formula for the potential of an ellipsoid. The author then deduces a





Physical Society, Jan. 16.—Prof. Gladstone, F.R.S., in the chair.—A paper was read on the electrolysis of certain metallic chlorides, by the President and Mr. Alfred Tribe. If metallic copper be immersed in solution of cupric chloride, insoluble cuprous chloride is formed upon it. The authors found that if a strip of platinum be connected with one of copper and the two immersed, the insoluble cuprous salt was also deposited upon the platinum. Attributing this result to the electrolysis of the cupric salt by a feeble current, they tried the effect of a zinc-platinum cell excited by common water and with two platinum electrodes in the cupric chloride. Cuprous chloride appeared at the negative electrode and chlorine at the positive. An ordinary Grove's cell also gave cuprous chloride for the first two or three minutes, but afterwards metallic copper. A zinc and a platinum plate were joined and immersed in the cupric chloride; cuprous chloride was deposited upon the platinum, the edges being also incrustated with metallic copper. With magnesium in place of the zinc, a larger proportion of copper was obtained. Mercuric and ferric chlorides being analogous to those of copper, induced the authors to experiment with them also. Precisely analogous results were obtained, mercurous and ferrous chlorides appearing at the negative electrode.—A communication was made by Prof. Guthrie on "Salt Solutions and attached Water." Continuing the direction of research previously indicated, and the results of which were communicated to the Society in November last, the author described the following facts:—Contrary to the generally received opinion, the minimum temperature attainable by mixing ice with a salt is very independent of the ratio of the two and of their temperature, and of the state of division of the ice. The temperature of a mixture of ice and a salt is as constant and precise as the melting-point of ice. The nine salts resulting from the union of potassium, sodium, and ammonium, on the one hand, and chlorine, bromine, and iodine on the other, were examined in reference to their cryohydrates, the temperatures of the formation of which range from  $-28$  to  $-11$ . For the same halogen, sodium salts assume less water than ammonium, and ammonium less than potassium. For the same metal, iodine salts assume less water than bromine, and bromine salts less than chlorine. The result of the examination of thirty-five salts establishes the identity of the temperature at which the cryohydrate is formed with the temperature got by mixing the salt with ice. Only two apparent exceptions to this identity have been as yet observed. The temperature at which a cryohydrate is formed is, with similar salts, lower, according as it assumes a less molecular ratio of water. There appear to be no exceptions to the rule that the lower the temperature got by mixing the salt with ice, the lower the molecular ratio of water. The temperature of incipient solidification of spirits of wine of different strengths was also examined. It was found that from spirits containing more water than the four hydrate, pure ice was separated, and that the temperature gradually sank to  $-34^{\circ}$  C., when the ratio of the four hydrate was reached. Thence the temperature remained constant, and the whole solidified into a hard mass. When a spirit richer than this cryohydrate is cooled, the cryohydrate separates, and a stronger and stronger spirit is left, which ultimately defies the source of cold (solid carbonic acid) to solidify it. Prof. A. Dupré's experiments regarding the maximum temperature produced on diluting alcohol are thus singularly confirmed. For this experimenter showed that this very four molecule ratio produced the greatest heat in its formation. Ethylic ether, which dissolves water and is dissolved by it, seems to form a definite cryohydrate. Water saturated with ether solidifies at  $-2^{\circ}$  C. without separation of ether. Theicy mass when ignited burns with a colourless flame, the heat of which just suffices to melt the ice.

## PARIS

Academy of Sciences, Jan. 18.—M. M. Fremy in the chair.—The following papers were read:—On the saline matter which the sugar-beet takes up from the soil and from manure, by M. E. Peligot; experiments which the author made with ten specimens of beet, all treated differently with regard to soil and manures, and tables of results obtained when analysing their ashes.—On the temperatures under turf or naked ground during the late frost, by MM. Becquerel and E. Liequerel.—A note by M. de Lesseps, on a project of communication between France and England, by means of a submarine tunnel, with an extract of a detailed account of this project as presented to the French National Assembly. M. Dupuy de Lôme then spoke against this project, and expressed himself in favour of a "channel railway ferry."—On the régime of the principal rivers in the north,

centre, and south of France, by M. Belgrand.—A note on M. Gosselin's paper of the last meeting (see NATURE, vol. xi. p. 240) with regard to unmovable dressings of wounds, by M. Ollier. Baron Larrey then made some further remarks on the subject.—On the first method of Jacobi for the integration of equations with partial derivatives of the first order, by M. G. Darboux.—On a system of tangential co-ordinates, by M. Casey.—On the deposits of flint implements near Précy-sur-Oise, and the presence of great pachydermata in the diluvium of the same locality, by M. E. Robert.—A note by M. de Lontin, on his ameliorations of dynamo-electric machines.—A note by M. Bonnel, on an aeronautical apparatus.—A note by M. E. Duchemin, on a new compass that can be used on the surface of liquids, and gives the time by the sun.—A note by M. C. Beuchot, on the application of steam for canal and river navigation.—On the causes of wear and tear and explosions of steam-boilers, by M. F. Garrigue.—MM. Blandin, Baruzzi, Mosca, and Guillaumont, sent some communications on Phylloxera.—The Minister for Foreign Affairs transmitted to the Academy some documents received from the French Consul at Mauritius, on the results obtained by Lord Lindsay in the observation of the transit of Venus. The French Consul at Honolulu sent some details on the same subject with regard to observations made by English expeditions at Honolulu, Hawaii, and Kanai.—A letter from the Minister for Agriculture and Commerce, drawing the attention of the Academy to the steps that ought to be taken to prevent the invasion into France of the fly *Doryphora*, which attacks the potato plantations in the United States.—On the notion of general systems of algebraic or transcendental surfaces, deduced from that of *implexes* of surfaces, by M. G. Fouré.—On the stellar system, 61 Cygni, stars physically related, the relative motion of which is not an orbit but rectilinear, by M. Flammarion.—Account of the discovery of asteroid (141), at the Paris Observatory, by M. P. Henry.—On the ammonia in the atmosphere, by M. A. Schloesing.—Researches by M. Müntz, on the respiratory functions of fungi.—On the decomposition of Fehling's liquor, and the admixture of glucose in the presence of sugar, by MM. P. Champion and H. Pellet.—On the pulsations of the heart, by M. Marey.—On the carrying along of air by a steam or air jet, by M. F. de Romilly.—On the phenomena of mineral and organic localisation with animals, and their biological importance, by M. E. Heckel.—On the development of Pteropoda, by M. H. Fol.—The neutralisation of the acidity of chloral hydrate by carbonate of soda retards the coagulation, while it preserves the physiological properties, by M. Oré.—Researches on the siliçified plants of Autun and Saint-Etienne, by M. B. Renault, with special reference to the genus *Botryopteris*.—On the influence of forests upon rivers and the hygrometric state of the atmosphere, by M. L. Fautrat.—On the breaking of vessels by the freezing of water, by M. A. Barthélemy.—During the meeting the Secretary announced the sad loss the Academy had sustained through the death of M. d'Omalius d'Halloy, of Brussels, correspondent of the Academy's Mineralogical Section. M. C. St. Claire-Deville then spoke a few words in memory of the deceased.

## CONTENTS

	PAGE
THE MARQUIS OF SALISBURY ON SCIENTIFIC EDUCATION . . . . .	241
SOUTH AMERICAN TRAVEL ( <i>With Illustrations</i> ) . . . . .	251
MOORHEAD'S "HARVESTING ANTS AND TRAP-DOOR SPIDERS" . . . . .	245
THE UNIONIDE . . . . .	240
OUR BOOK SHELF!—	
Dr. le Bon's "Human Physiology" . . . . .	246
LETTERS TO THE EDITOR:—	
Fossil Remains of the Fallow Deer found in Malta.—Prof. A. LEITH ADAMS . . . . .	247
Electric Conductivity of Nerves.—Dr. JOHN DRYSDALE . . . . .	247
Kirk's Physiology.—E. PRIDEAUX . . . . .	248
The Rhinoceros in New Guinea.—ALFRED O. WALKER . . . . .	248
Thomson's "Malacca"—W. L. DISTANT . . . . .	248
Bees and Flowers.—MARY J. PLARR . . . . .	248
Iron Pyrites—Curious Phenomenon.—FREDERIC CASE . . . . .	249
OUR ASTRONOMICAL COLUMN:—	
Fossil Animals as a Double Star . . . . .	249
The "Temporary Stars" of Tycho Brahe and Kepler . . . . .	249
The Zodiacal Light . . . . .	249
PLANETARY THEORIES. By M. LEVERRIER . . . . .	249
RUSSIAN FORESTS . . . . .	251
THE INDIA MUSEUM . . . . .	252
UMBRELLA, OR CLUSTER POLYP . . . . .	252
SCIENCE IN THE ARGENTINE REPUBLIC . . . . .	253
NOTES . . . . .	253
ON THE MUSCULAR MECHANICAL WORK DONE BEFORE EXHAUSTION. BY FRANK E. NIPHER . . . . .	255
SCIENTIFIC SERIALS . . . . .	257
SOCIETIES AND ACADEMIES . . . . .	258

THURSDAY, FEBRUARY 4, 1875

## BOTANICAL PROBLEMS\*

SUCH is the title of an article by Prof. Cohn on the history of botany in the new German periodical, the *Deutsche Rundschau*.

Circumstances seem to have determined the direction of the researches of English botanists of the present period, who, almost without exception, have devoted their whole time to descriptive botany. On the other hand, continental botanists have pursued vegetable physiology and anatomy with great assiduity. This separation of what should be inseparable branches of the same science is in all probability only temporary. The great demand for descriptive works on the vegetation of our various colonies, and the immense mass of undescribed plants in our herbaria, have, doubtless, influenced in no small degree the direction of the labours of our botanists. In return, poverty in herbarium specimens and books renders it impossible for many continental botanists to pursue successfully systematic botany. Apart from its importance from an economic point of view, descriptive botany is of relatively little absolute value, and must be extremely unsatisfactory to minds labouring to prove the immutability of species on the one hand, or their variability within certain defined limits on the other. Whether we follow Jordan, with his 200 species of *Draba* (*Erophila*), the result of the dismemberment of *D. verna*; or Regel, who combines *Vitis vinifera*, *Labrusca*, *vulpina*, &c., we should equally drift into an utterly impracticable and useless system, and one of no utility whatsoever in the solution of problems which we may reasonably hope to unravel.

This brings us to a consideration of Cohn's article, professedly written to show the importance and popularise the study of botany, more particularly in its biological bearings. Naturally we may look for some tolerably sharp criticisms of systematic botany studied alone, and the writer is to some extent justified in more especially singling out England. Nevertheless, we think that its importance is underrated by some continental botanists. Prof. Cohn is a great admirer of the Aristotelian school, and to the great master and his pupil, Theophrastus, he gives the credit of having initiated the scientific study of plants, which after their time declined and lay dormant for upwards of 2,000 years. The discoveries of the last two centuries he consequently looks upon as a revival of this science, and as so many solutions of problems propounded, though, as he admits, not answered, by Theophrastus. We certainly should assign a more modest share of credit to these early philosophers, and Cohn's quotation from Goethe, "when we consider the problems of Aristotle we are astonished at the great powers of observation and universal perception of the Greeks; but they are too hasty, passing at one step from the phenomena to their interpretation, hence their conclusions are often inadequate and theoretical," does not strengthen his position. After all, this is a question of little moment. It is quite true that nothing approaching a philosophical

study of plants was resumed before the seventeenth century.

Prof. Cohn gives a sketch of the history of botany, hastily disposing of the "root-grubbers and collectors of simples," from Dioscorides and Galen down to the herbalists of the seventeenth century. To Erasmus he traces the impulse given to this and other branches of learning in the Netherlands and North-western Germany. The fact that the dwellers on the Rhine did not find the same plants described by Dioscorides, may be said to have offered the first lesson in phytogeography, which was rapidly developed by the spirit of travel and discovery which soon set in.

Naturally one of the first things to impress itself on the minds of those engaged in the study of plants as their numbers increased, was the necessity for some system of classification and nomenclature. The history of binominal nomenclature and the sexual system of Linnæus, and the natural system of A. L. de Jussieu, are too well known to need repetition, and Cohn does not attempt to trace the gradual growth of knowledge which led up to the development of these ideas. In fact, he appears to attach so little importance to systematic botany, that he goes on to say: "Under the dominating influence of Linnæus, botany seems to have stagnated more and more, whilst a new spirit had been infused into the study of other sciences." He then refers to the philosophical teachings of Bacon, which fell upon a well-prepared soil and eventually bore fruit. Botanists began to make experiments and study the laws of nature. Hales was the first to investigate some of the phenomena of plant life in their physical aspects. Du Hamel, Bonnet, Ingenhousz, Priestley, Saussure, and others followed, and raised the study of vegetable physiology and chemistry to a level with the exact sciences. The solution of other botanical problems is given in outline, and where only a few names could be given it is not to be wondered at that Germans figure more prominently than would be the case in a detailed history. The merit of solving a particular botanical problem can in few instances be claimed for one man alone. Discovery is progressive, and a complete insight into many of the processes of plant-life have been gradually unfolded. Goethe's solution of the morphological problem is naturally dwelt upon at some length, and no one will gainsay its importance in systematic botany. Grew and Malpighi initiated vegetable anatomy, and it is a noteworthy fact, says Cohn, that the papers of these two fathers were handed over to the Royal Society of London on the same day, Dec. 29, 1671. But a hundred years elapsed before their labours were appreciated and continued.

In the revival of this branch of botany Prof. Cohn has a strong array of German names, many of them of world-wide fame. The conceptions of Darwin and their importance are barely mentioned, though in no country have they exerted a more fundamental influence than in Germany. Passing into the region of unsolved problems, Cohn cites the unconquerable vitality of the potato fungus, and the uncertainty existing respecting the presence and signification of minute fungi in cholera and other diseases.

In conclusion, Prof. Cohn rejoices in the fact that botany has freed itself from the fetters which formerly

\* "Botanische Probleme," von Prof. Cohn (*Deutsche Rundschau*, Heft 1).

limited its field of operation and discovery. "It has already furnished us with a clue to many of the mysteries of life, and we look to it for many more: what is life? what is death?" This last quotation will show that he puts no limit to the phenomena to be considered in the investigations of the biologist; but when man has solved all these problems, he will be as wise, if not as powerful as the gods.

### SOUTH AMERICAN TRAVEL\*

#### II.

*Travels in South America, from the Pacific Ocean to the Atlantic Ocean.* By Paul Marcoy. Illustrated by 525 engravings and ten maps. Two vols. (London: Blackie and Son, 1875.)

*The Amazon and Madeira Rivers: Sketches and Descriptions from the Note-book of an Explorer.* By Franz Keller, Engineer. With sixty-eight illustrations on wood. (London: Chapman and Hall, 1874.)

*Two Years in Peru, with Exploration of its Antiquities.* By T. J. Hutchinson, M.A.I. With map and numerous illustrations. Two vols. (London: Sampson Low, 1873.)

MR. KELLER'S work is a much more business-like and compact production than that of M. Marcoy, noticed in last week's number. While the beautiful illustrations which enrich the book show that the author has a high power of artistic reproduction, and while this may have led him to throw over the scenes he endeavours to reproduce a little touch of glamour, a little of "the light that never was on sea or land," one feels on reading Mr. Keller's narrative that he is in the hands of a thoroughly earnest and trustworthy observer. He has, however, committed the sin of publishing a narrative of exploration without a map. We should mention also that not one of the three books we are noticing contains an index, a want which will considerably impair their usefulness to the student.

Mr. Keller's work is almost entirely concerned with the Madeira, the largest tributary of the Amazon from the south. His journey from the time of his departure from, till his return to Para was accomplished between November 1867 and December 1868, a period of thirteen months, during which, including vexatious delays, he ascended the Madeira as far as Trinidad, on the Mamore, in Bolivia. If our readers look at a map, they will see that Mr. Keller could not have been idle during the time, especially when it is remembered that his purpose was to make a careful hydrographical inspection of the Madeira, in order to report upon the possibility of utilising it as a navigable highway for commerce.

The river, as far as Santo Antonio, seems capable of being rendered quite navigable, but above this the rapids are so numerous and formidable that it seems hopeless to expect that the upper river can ever be made available for anything but boats. The only means, therefore, by which the treasures that exist in the interior of South America can be made accessible by the Madeira route is by a railway from Santo Antonio upwards. It would seem that some such project is in contemplation. The construction of railways, we learn from Mr. Hutchinson's work, is

being carried out rapidly in Peru on a very extensive scale, mainly under the superintendence of Mr. Henry Meiggs, who has difficulties of the most formidable kind to contend with in piercing the Andes; in a short time, however, we may expect to see all parts of this country easy of access. In Brazil the mere engineering part of the work would seem to present no difficulties whatever.

Before any such scheme is carried out, ere the whole of this primeval region be deviginated by swarms of white men, we hope that its natural history and ethnology will be fully if not exhaustively investigated. In this respect such works as those of Marcoy and Keller are of great value.

Mr. Keller made excellent use of [the short time he spent in the interior; for while he most faithfully and successfully accomplished the mission with which he was entrusted, he at the same time made a series of really valuable observations on all that he saw that was worth noting. His narrative is not, however, arranged in the same method as that of M. Marcoy, who recounts each day's experience as he proceeds, and in whose case, therefore, the want of an index is peculiarly felt. Mr. Keller has systematised the results of his journey, and in a series of chapters gives a clear and well-written summary of his observations. In an introductory chapter he gives a brief account of what is known of the physical and social condition of Brazil and of its political history. He then, in two chapters, gives a sort of itinerary of his expedition up the Madeira, with occasional observations on the inhabitants and the natural history of its banks, and a very clear and full account of the difficulties attending his attempt to navigate the river, so studded with rapids, past every one of which his fleet of boats had to be carried. The region seems to be very sparsely peopled, though its natural resources are superabundant. The material of the hills over the whole region of the rapids he found to be the same; "gneiss, with mostly a very pronounced stratification, and always the same run. He examined it very closely," he states, "expecting to find, according to theory of Agassiz, numerous erratic boulders of different composition lying on the regularly formed rock. But neither there nor higher up in Bolivia could we discover any trace of these 'foundlings,' even as Agassiz himself was unable to discover, in the environs of Rio de Janeiro, the *roches striées* and *roches moutonnées* of Switzerland, which testify to an ice-period with its immense glaciers."

In the chapter headed "Canoe and Camp Life," Mr. Keller gives a graphic account of the daily life of an expedition such as his; and in another, on "Hunting and Fishing," he gives a pretty full idea of the larger fauna to be met with on the route he traversed. In the succeeding one he describes the vegetation of the virgin forest of the Madeira and Amazon, devotes considerable space to the Caoutchouc Tree which so abounds here, and to an account of the process by which its sap is converted into the india-rubber of commerce. He also gives a list of the other principal plants which are utilised for commercial purposes, in the shape of medicines, oils, resins, dye-stuffs, ropes, &c.; and it strikes one that it would certainly be worth while to make a region so superabundantly stored with animal and vegetable life of such great practical utility to man, easily accessible to the merchants of the world.

\* Continued from p. 245.

To the wild tribes of the Madeira Valley, the Múras, the Arúras, the Mundrucús, the Perententins, the Caripunas, &c., Mr. Keller devotes a chapter. By the encroachment

of white men, and by the ministrations of the Jesuit missionaries, these tribes, like many others in South America, are considerably changed from what they were when the

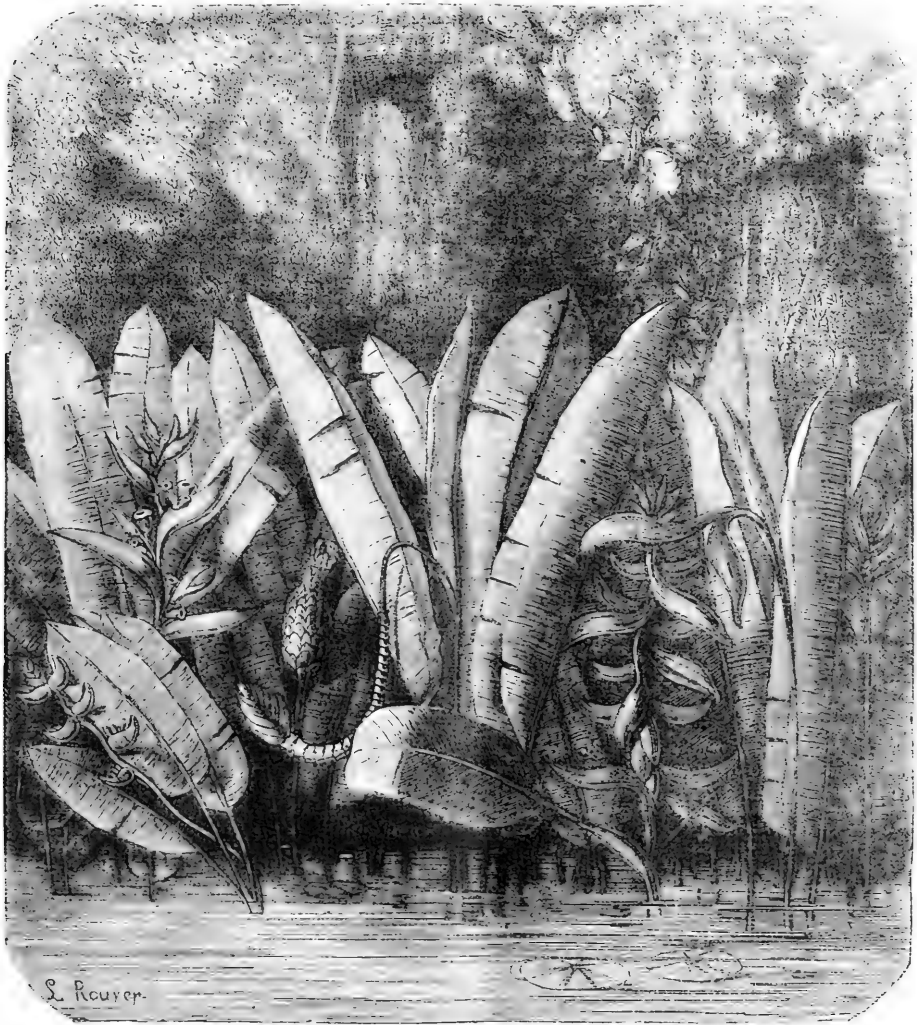

FIG. 3.—Reeds (*Canna*) on the Ucayali.—Marcoy.

continent was first discovered, and, as we said in our last number, are much diminished in numbers. If we may trust the individuals who figure in Mr. Keller's illustrations, there must be some splendid specimens of men and

women among them. The Indians in this region are, however, far from being tamed, and not unfrequently resent the encroachment of the white man after a very bloody fashion, though wherever they come in contact

with the latter "their doom is sealed," as Mr. Keller truly says. He justly cries out upon the sentimentality which laments the extinction of the "noble red race," a race which exists only in the pages of the novelist. The red race of North America must soon become extinct, and leave its hunting-grounds in entire possession of the white man, who will make a better use of them than ever did the aboriginal possessors; and we fear, if the red man of South America proves himself no fitter to survive than his northern brother, he must follow the latter to those "happy hunting-grounds" where no white man is ever likely to intrude. Looked at, as Mr. Keller says, in the broad light of what is the best for the race as a whole, however sorry we may feel for the "poor Indian," and still more so for the race or races that have left so many astounding monuments of their advancement along the west coast of South America (and in some parts of North America, it would be useless, if advisable, to attempt to prevent it. There seem to exist evidences in America, as elsewhere, that probably before the advent of any existing people the earth had its human inhabitants, who were compelled to melt away before others of a higher type, who again had to succumb before still stronger brethren. This process has been going on as far back as we can trace, and when it will cease, if ever, who can tell?

Among all the numerous tribes of the interior of the South American continent, Mr. Keller discovers two well-marked types. "One of them, the Guarani, of the widely-spread Tupi tribe, showing the well-known eagle-profile of the North American Indians, first-rate pedlars and fishers, generally keep near the large rivers; while the others, the Cervados, or Ca-en-ganges (forest-men), as they call themselves, more warlike and high-handed, carrying off and enslaving whomsoever they can, do not use canoes at all, and prefer the wooded ravines of the lateral valleys, or the grass-grown ridges of the Campos. . . . Their oblique eyes, short nose, and high cheek-bones, strongly remind one of the Mongolian type, though by this remark I would not imply their direct Asiatic origin. . . . The Guarani, although their outward appearance and character recall the old Mexican tribes, seem to have come in all probability from the south, and to have spread thence all over the continent." As these statements are given in Mr. Keller's introduction, they may be regarded as not so much the direct results of his own observation, but as to a great extent a statement of the most approved theory of the native American populations. It tallies to some extent with the theory contained in Marcoy's work, and with the conclusions reached on craniological grounds by some of the best existing anthropologists. It seems to us, however, that before any definite conclusion can be reached, much yet remains to be done. Meantime we may say that we consider Mr. Keller's work a valuable contribution to the literature of South American Travel; the illustrations are delightful, and the engraver has done his part in a masterly style.

The chief value of Mr. Hutchinson's work, from our point of view, consists in the detailed account he gives of explorations among the still mysterious ruins which litter the maritime districts of Peru from south to north. But this is not its only value. Mr. Hutchinson was two years in Peru—1871-73—as her Majesty's Consul at Callao,

and during that short period his work proves that not only did he find time to explore nearly every important cluster of ruins in the country, but to make himself master of the social, political, and industrial position of the republic. His picture is a somewhat brighter one than that given by M. Marcoy twenty-three years before, and it would seem that the country has really advanced in several respects during that period. By means of several excellent steamship companies it is now in almost daily communication with North America and Europe, and this has led to a considerable development of its resources. As we have already said, railways are in course of construction all over the country, and it is even in contemplation to carry one right through the Andes to the Ucayali, by which the problem of direct communication between the east and west coasts would be solved. Education seems to be claiming some attention, and a Society of Arts has been founded, which we sincerely hope will give early and energetic attention to the prehistoric ruins which enrich Peru, from which so much has yet to be learned concerning their history and their builders. The people, however, have still much laziness to get rid of; but we hope that under the intelligent and vigorous administration of President Pardo, and the stimulus of increased communication with other nations, they may gradually be aroused to healthy exertion.

It is unnecessary to enter into details concerning the Peruvian ruins, the nature of which is known to most of our readers. Colossal walls of adobes, or large sun-dried bricks, the remains of immense buildings whose purpose seems yet doubtful, terraced mounds or hills hundreds of feet in height and covering an area of several acres, aqueducts, huacas, or burial mounds, containing thousands of carefully-buried skeletons, with the knees and hip-joints bent, some of them with the hair and bits of flesh still adhering, with their original wrappings and the articles placed beside them when they were buried; abundant remains of pottery, many of them giving evidence of considerable ingenuity, skill, and taste in the makers; masks, images, and other relics, all affording evidence of a numerous population of great energy and of a civilisation of no mean grade.

The great question in connection with these remains is, who were the original builders? As our readers know, the generally accepted story is that they were built by the Incas, the name given to the race dominant in Peru for some centuries previous to the advent of the Spaniards. This, however, is not the opinion of Mr. Hutchinson, who has no patience with the advocates of this theory, and who has rather a contempt for the Incas as the destroyers of a civilisation much higher than their own. He regards Garcilasso's history as a mere piece of gasconading. His own theory seems to be that the Incas found the buildings whose remains still exist, when they made their advent in Peru, and forced upon the people whom they conquered the worship of their great deity the Sun. The real builders were the Yuncas, who dispossessed the Chinchas, the latter themselves finding upon their arrival an aboriginal race, some relics of whom Mr. Hutchinson believes have been found sixty-two feet deep under the guano deposit on the Chincha Islands. When we consider the slowness with which these droppings of birds must have accumulated, it carries back the first advent of

man in South America to a time which must be measured by thousands of years.

It seems to us a herculean task to attempt to unravel the ethnology of Peru, which we suspect can only be adequately done in connection with that of the whole American continent; but it is a task which is well worth attempting. A vast amount has been written on the subject, and there exists a great wealth of material; it seems to us that

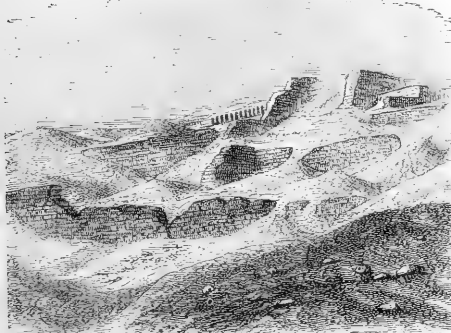

FIG. 4.—Ruins of Reputed Temple of the Sun at Pacha-cámac.—Hutchinson.

what is now wanted is a man possessed of the necessary wide grasp of mind and extensive knowledge to set himself to collect, arrange, and sift this material and investigate on strict scientific principles the bearing of the results. From such a process, we believe, some definite

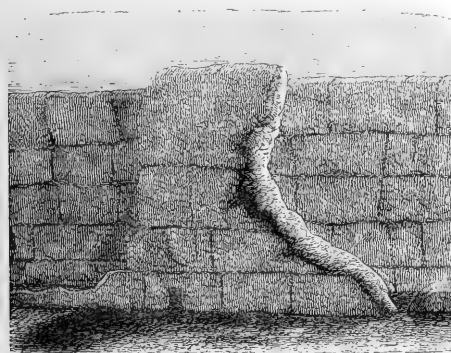

FIG. 5.—Part of Ruins of Double Wall of Temple of Rimac.—Hutchinson.

and valuable conclusions would be arrived at, as definite, perhaps, though not nearly so comprehensive, as those which have been reached concerning the Indo-European peoples; for there still remains much material to bring together, and no time should be lost in setting about the work. Mr. Hutchinson suggests that if some one would do for the remains in Peru what Schliemann has done for those of Troy, and George Smith has done for those in

Assyria, the results would be of higher value than any yet achieved. Let some one with the patience, enthusiasm, and knowledge of Dr. Schliemann, devote the necessary time to the careful excavation and study of the mounds and clay-covered buildings, and we are sure the results will well repay the labour. Let us hope that the present Peruvian Government will be patriotic and generous enough to inaugurate and bear the expense of the work, and thus gain for themselves the admiration and thanks of the civilised world. Talking of Dr. Schliemann, Mr. Hutchinson points out some very remarkable coincidences between the buildings and relics which that explorer has unearthed, and those which Mr. Hutchinson himself has found in Peru. Whether this be more than a coincidence it would be rash at present to conjecture.

Mr. Hutchinson's work must be regarded as one of the most important contributions that have been made to the archaeology of Peru, and we hope that though no longer resident in the country, he will continue to investigate the subject and help to reduce its present confusion to something like order. We think, however, he might have a little more patience with the theories of other investigators, and not hastily cast them aside as unworthy of notice; the labours of all competent and earnest workers should be seriously studied, for thus only can the full truth be arrived at; even in the legends of Garcilasso he might find some speck of valuable truth.

*WATSON'S "DESCRIPTIVE GEOMETRY"*  
*A Course in Descriptive Geometry.* By William Watson, Ph.D. 4to. double columns, pp. xi, 147, with thirty-two plates and three double plates of stereoscopic views. (Boston: Osgood and Co. London: Longmans, Green, and Co., 1874.)

DESCRIPTIVE Geometry affords the practical means of dealing with geometry in three dimensions, in the same manner that Practical Geometry, that is to say, the intelligent use of drawing and of graphical methods, deals with plane geometry. If, in solid geometry, we concerned ourselves only with points and with lines, whether straight or curved, we might say that descriptive geometry was simply the science of plan and elevation. As regards the point and the line, it is nothing more. But what distinguishes descriptive geometry, as it was published to the world in Monge's celebrated treatise, from what was already known to every intelligent builder or carpenter, is the means of *indicating* surfaces, whether plane or curved, as well as of *representing* points or lines. We use the terms *indicating* and *representing* advisedly, as carrying with them a real distinction, which, we regret to see, is not always brought prominently forward in the treatises, and sometimes fails to be perceived by the student until he has wasted valuable time in groping after a misapprehension. It is indeed evident that a surface cannot be represented in the same sense that a point and line are, for its plan and elevation would be simply two black patches, the contours of which would give the boundaries of the surface in certain directions, but would fail to represent the surface itself. Now, the method published by Monge regarded a surface, whether plane or curved, as completely indicated so soon as its geo-

metrical law of generation was described and the position and aspect of its principal elements indicated on the paper.\* Its indication was then complete, and the representation of any points or lines upon it was then reduced to the devices of practical geometry. The principle simply was that a surface might be regarded as completely known when we had indicated a method of taking an infinite number of sections of it. In the simplest case, these would be parallel plane sections, as in the ordinary drawings of a ship, but Monge's method was not trammelled by this restriction.

Like most large subjects, it is one which it is very difficult to know how to treat with advantage to the student. An exhaustive treatise is out of the question for any learner who is not prepared to make it an exclusive or principal study, and it is a matter of very nice judgment what to select and how much to present to the pupil; and this is the more emphatically so, inasmuch as it is really the only good introduction to a practical insight into the geometrical properties of space.

Viewed in this light, the treatise before us is an exceedingly good one. With great clearness and precision, it covers a considerable extent of ground, and that by no means baldly; and yet it is not too long. It has, moreover, a very valuable adjunct, and one which, we believe, is quite new—a series of stereoscopic drawings exhibiting the actual construction *in solido* of thirty-six of the principal problems. To the ordinary student this will be of immense assistance; for it is well known to teachers of geometry and of mechanics, that want of imagination on the part of the student is one of the principal obstacles they have to deal with in endeavouring to impart to him accurate conceptions of space and of motion. These drawings have been very clearly and judiciously executed by Prof. Saint Loup (of Paris), and slight colouring has been introduced in some of the examples of intersection with marked advantage and success.

We notice some peculiarities of language in which English usage is slightly departed from, as in writing *warped* surfaces instead of skew surfaces, in spelling the word *director* with two *d's* instead of "director," and in the use of the word *raccord* to express that two surfaces have a line of contact. Some of these, having regard to the unsettled English nomenclature of an imported subject, are not blemishes, and none of them detract from the really high value of the book.

Some account is also given of the leading spherical projections, especially the orthographic and the stereographic. These are important additions to the treatise, and although we would gladly have seen some others described, particularly the gnomonic projection, we think the author has done wisely in not unduly extending this part of his treatise.

The book is of convenient size, clearly printed, and well arranged, with a good table of contents. Altogether, we think it one of the best books upon the subject which we have yet seen, especially in English, and we think it does the highest credit to the distinguished American professor who is its author.

\* It is certain that Monge did a great deal to systematise and complete the method; but some of its principles were certainly known, although carefully kept secret, in some of the higher French schools. In consequence of this secrecy, it will probably never be known exactly how much is due to Monge; but we may well believe that Monge did for this science what Newton and Leibnitz did for the infinitesimal calculus.

## PHILLIPS' "ELEMENTS OF METALLURGY"

*Elements of Metallurgy: a Practical Treatise on the Art of Extracting Metals from their Ores.* By J. Arthur Phillips, M. Inst. C.E., F.G.S., F.C.S., &c. (London: Charles Griffin and Co., 1874.)

OF all the sciences, Metallurgy is the one whose history extends into the most remote antiquity, and there is abundant evidence to show that even complicated metallurgical operations were performed empirically long before the physical sciences existed.

Until within comparatively recent times the number of eminent chemists who devoted themselves to metallurgical work was more commensurate with the importance of the subject than at the present day, when, we venture to think, too many are lured away by the attractions of organic chemistry and abstract speculations as to the existence of matter. Notwithstanding this, within the last few years the science of metallurgy has made great advances, but the works on the subject published in this country have been singularly few; Dr. Percy's admirable work is still incomplete, and, with the exception of the translation of Keri's "Metallurgy" by Crookes and Röhrig, there is no work which is even fairly comprehensive. The edition of Mr. Phillips' "Manual of Metallurgy" published in 1858 has become almost useless, but the volume just issued is an important addition to this branch of literature.

The physical properties of metals are fully and carefully treated, and eighty pages are devoted to the consideration of fuel. The description of iron ores is very good, the author having closely followed Bauerman, and no pains have been spared to render the portion of the work which treats of iron as complete as possible. Among the numerous carefully executed engravings are drawings of roasting and calcining kilns, and of the blowing engine and blast cylinder at Dowlais.

The next important metal, copper, is discussed at some length, and the description of the "wet methods" of extracting this metal is specially valuable, as the author writes from long experience of operations which have been conducted under his own direction. It is interesting to note that processes such as those carried on at Widnes, Alderley Edge, and Jarrow-on-Tyne, are applications, on a manufacturing scale, of methods ordinarily used by the chemist in his laboratory, and, as such, they afford singularly important evidence of the progress of metallurgical science.

Lead is treated at some length, special attention being devoted to the extraction of this metal by means of reverberatory furnaces. Excellent drawings are given of those employed in the works at Couëron, where galena associated with carbonate of lead is partially converted into oxide and sulphate by roasting, which subsequently react, at a more elevated temperature, on the undecomposed sulphide in the charge, producing metallic lead.

The articles on silver and gold are condensed from the author's well-known work on the mining and metallurgy of these metals, some new matter being added; they leave little to be desired, but the forms of apparatus for assaying which are described, are not in all cases the most perfect.

Fifteen metals are treated in the work, and these are



by far the most important commercially; nevertheless, we could have wished to find brief accounts of such metals as manganese, magnesium, cadmium, palladium, potassium, and sodium.

We have already referred to the excellence of certain drawings, and it is only necessary to add that throughout the volume the illustrations are of very high merit. They are evidently drawn from actual measurement, but it is to be regretted that scales are not given.

The author states in his preface that the object which he had in view was "to supply, within moderate limits, such practical information on general principles, and typical processes, as may not only afford a comprehensive view of the subject, but also enable the reader to study with advantage more elaborate treatises and original memoirs." Certainly this object has been attained; and we think he has done more, in that he has produced a work which not only fully sustains his reputation, but affords fresh evidence of his having done much scientific work of a kind far too rare in this country.

### OUR BOOK SHELF

*Descendenzlehre und Darwinismus.* Von Oscar Schmidt. (Leipzig: Brockhaus, 1873.)

THIS volume of three hundred pages is one of the "International Scientific Library." It is a moderate exposition of the Darwinian theory of Evolution, intended for general readers, and while free from the eccentricities of Hæckel's Anthropogenie, also lacks the brilliancy and power which redeem its faults. Prof. Schmidt while still at Gatz became a convert to "the new philosophy," and in his *Vergleichende Anatomie* (NATURE, vol. v. p. 228) adopted its conclusions as the basis of his teaching. In a paper read before the "British Association" of Germany two years ago, at Wiesbaden, he stated and defended his change of opinion, and now that he is established as professor in Strassburg University, he puts forward this volume as a fuller exposition of his views—"for here one must show one's colours." It is perhaps undesirable for people to attempt arriving at the results of science by such easy roads as popular treatises, and "The Descent of Man" itself is a better interpretation of Darwinism than the expository treatises of Darwinists; but there is undoubtedly a demand for books of this kind, and if they are to be written, it is well that so competent a hand as Prof. Oscar Schmidt's should do it. There are several woodcuts, a good list of references, and the inevitable genealogical trees.

We also note the appearance of an essay attacking the theory of Evolution, by Prof. Wigand, of Marburg; and a reply to it by Prof. Jäger, of Stuttgart. The former, entitled *Darwinismus und die Naturforschung Newton's und Cuvier's*, is a temperate production, written from the point of view of a botanist. The latter is a more lively rejoinder, and appears as *In Sachen Darwin's inbesondere contra Wigand.* P. S.

*The Micrographic Dictionary: a Guide to the Examination and Investigation of the Structure and Nature of Microscopic Objects.* By J. W. Griffith, M.D., and A. Hentley. Third Edition, edited by J. W. Griffith and Prof. M. Duncan, assisted by the Rev. M. J. Berkeley and T. Rupert Jones. (London: J. Van Voorst, 1875.)

WE have from time to time chronicled the progress of this work, and have now the satisfaction of announcing its completion. In a work of this kind, which has been upwards of three years in passing through the press, it is inevitable that minute criticism should detect some

discrepancies between the various articles, and some passages in the earlier pages which would not have been written in the light of more recent investigations. It is probable, also, that workers in different fields will place a different estimate on the importance of their own department, and will be disposed to grudge the space devoted to others. The student of Cryptogamic Botany has at all events the lion's share, almost every genus in some groups being described. In the present chaotic state of the classification of Cellular Cryptogams, it is probable that a number of the genera and even groups treated of in this work as autonomic will have ultimately to be abandoned. There is, however, so much that is of the greatest value to every microscopist, that we can cordially recommend the work as indispensable to the student. The plates, some of which are new, and others re-drawn, are of themselves of great and permanent value.

*Temperature Chart of the United States, showing the Distribution by Isothermal Lines of the Mean Temperature of the Year.* Constructed under the direction of Prof. J. Henry, Secretary, Smithsonian Institution, by Charles A. Schott, Assistant U.S. Coast Survey, in October 1872.

THIS temperature chart, which by the way should have been accompanied with some explanatory remarks, has been issued by the Smithsonian Institution. The isothermals are given for every 4° F., beginning with 36° in Minnesota and the northern shores of Lake Superior, and rising successively to 76° in the extreme south of Florida. The lines have evidently been drawn from mean annual temperatures, uncorrected for height, and are therefore designed to show the actual distribution of mean annual temperature over the surface of the United States. This method of representing the distribution of temperature, which has been employed by Petermann and others, is well suited for various purposes for countries, such as Russia, which consist chiefly of extensive rolling plains; but it is not suited for Scotland, Switzerland, and other mountainous regions. In the mountainous parts of Great Britain, for instance, isothermals so drawn, had we the data to do it, would be neither more nor less than contour lines. The fault of the chart consists in not keeping this distinction in view. Thus, in the Rocky Mountains, the isothermal of 44° passes over Denver, the mean temperature of which, on an average of three years, is 51°; and in the Alleghany Mountains, Ashville, N.C., lies within the closed isothermal of 48°, but its mean temperature on an average of four years is 54°. In constructing such charts, mountainous regions should be altogether kept clear of the isothermals. For the vast plains of the States the chart is a valuable one, and the tracing of the influence of the lakes, river basins, and more marked contour lines on the course of the isothermals, is very instructive. After a somewhat minute examination of the lines, we have only to note, in way of criticism, that the isothermal of 44° is drawn too far northward in the region of Lake Ontario; the mean temperature of Toronto being 44°·2 and Kingston 42°·8, showing that it should be drawn nearly along the northern shore of that lake.

### LETTERS TO THE EDITOR

[The Editor does not hold himself responsible for opinions expressed by his correspondents. Neither can he undertake to return, or to correspond with the writers of, rejected manuscripts. No notice is taken of anonymous communications.]

#### Sub-Wealden Exploration

IT must be with great regret that geologists see the announcement made in NATURE, vol. xi. p. 236, that all the efforts to clear the bore-hole at Netherfield have been unavailing, and that it has to be abandoned. But is it advisable, I would ask, that another should be commenced on the same spot? When the

1,000 feet were clear, it seemed desirable to go deeper, as no one could tell how soon the Palaeozoic rocks would be reached; but surely if it is to be recommended *de novo*, it would be better to select another site. We already know from the boring nearly all we care to know—that we are not there on the axis of Palaeozoic rocks, but in a basin.

The Kimmeridge clay, which is 240 feet thick at Marquise, becomes thicker in a south-westerly direction to 360 feet near Boulogne, and now we know that it reaches some 660 feet at a point six times the distance in a direction W.N.W., which thickening is continued to its outcrop under St. Alban's Head, though it thins again to the west. The coral rag which occurs in the Boulonnais is here gone through; it sets in again near Weymouth, and since this is followed in the former locality by 385 feet of Oxford clay and Lower Oolitic rocks, we may expect at least 600 feet of them at Netherfield before we reach Palaeozoic rocks, which will be almost certainly lower than the coal.

The facts so far ascertained by the boring prove, therefore, as much as we could wish to know, except the age of the Palaeozoic rock when met with, if that could be discovered from the small core. They show that the spot is to the south of the axis we are seeking, and the thickening of the Kimmeridge clay would tend to throw that axis some considerable distance to the north.

No such Jurassic beds occur at London, Harwich, or Calais; but the Cretaceous beds directly overlie the Palaeozoic. The conditions on one side and on the other are therefore very different. To the north the Palaeozoic rocks are spread out not so far from the surface, and on this side only have the coal measures been proved; to the south they are scooped, or dip, into a hollow, in the midst of which is the Netherfield boring, and which hollowing out would have removed all coal-bearing strata, even if originally there.

This verification of what might have been argued from facts already known has been given us by the Sub-Walden boring; what more can it do? It has proved that our interest is in localities further to the north, as Messrs. Godwin Austen and Prestwich supposed it to be. Doubtless no better locality, near Brighton, could have been chosen; but if what is essentially another boring is to be made, why not select a locality from which some fresh information might be obtained? A bore at Folkestone would probably pass through little or none of the Jurassic series; but the best place for a new experiment would be somewhere in the neighbourhood of Goring, which would be on the line both of Mr. Godwin Austen's and Mr. Prestwich's supposed range of coal-fields, and would afford a crucial test whether the Palaeozoic rocks are really continuous between London and Frome at an accessible depth; and this is what we most want to know.

If a new boring is put down at the same place, it would be well to have a third for some small depth, in order to obtain the dip by a comparison of corresponding beds.

Jan. 25

J. F. BLAKE

### The Rhinoceros in New Guinea

I AM quite of your opinion that the occurrence of a rhinoceros in New Guinea is *very seriously* to be doubted (see NATURE, vol. xi. p. 248), but I beg leave to mention a report of a *very large quadruped* in New Guinea, which I got from the Papuans of the south coast of the Geelvink Bay. When trying to cross the country from there to the south coast, opposite the Aru Islands, —in which I did not succeed, but only saw the sea-shore at a great distance from the height of a mountain chain (I afterwards succeeded in crossing the continent of New Guinea from the Geelvink Bay more to the north, over to the Maclure Gulf),—and when hunting wild pigs along with the Papuans, they told me, without my questioning them, of a *very large pig*, as they called it, fixing its height on the stem of a tree at more than six feet. I could not get any other information from them, except that the beast was very rare, but they were quite precise in their assertion. I promised heaps of glass pearls and knives to him who would bring me something of that large animal, but none did. I cannot suppose, so far as my experience goes, that the Papuans are remarkably prone to lies; notwithstanding I seriously doubted the existence of such a large "pig;" and as the sons of that country are very superstitious, and see ghosts and absurd phenomena everywhere, I may just mention as an example, that when I shot, on the same hunting party, a specimen of *Xanthomys aureus*, that most brilliant gold-orange Bird of Paradise, they said they could not kill this bird, because it would lighten and thunder when they did. I booked that report as an

efflux of their lively imagination, though not without discussing in my diary the possibility and significance of the occurrence of a large quadruped in New Guinea.

It is true this statement does not strongly support Lieut. Smith's *apercu*, but the one gains a grain by the other; I mean, the probability of the existence of a large quadruped in New Guinea increases a shadow.

The other "fact" mentioned by Mr. Walker (*l.c.*), concerning the skins of a brilliant red Bird of Paradise, which were obtained on the north-east coast, is an interesting *fact* indeed, because it appears to confirm M. d'Alberis's discovery of *Paradisa raggiana* on the south coast. It would be most valuable to compare the skins of the red Bird of Paradise from the north-east and the south coast, or at least those from the first with the coloured figure given by Mr. Elliot in his Monograph of the Paradisee, to become sure of their identity. At all events, if Von Rosenberg maintains (see Noll's "Zoologischer Garten," January 1875), that *P. raggiana* is an "artificial" skin, his assertion is strongly to be repudiated. "Similar frauds" he pretends to have seen in New Guinea, an assertion which is the bolder and the more inconsiderate, as he has not had under his eyes d'Alberis's skins. A. B. MEYER

Dresden, Feb. 1

I WAS no doubt wrong in speaking of the occurrence of the rhinoceros in Papua as a fact without the qualification "if confirmed;" but I wrote in a hurry.

From the details supplied by Mr. Smith, which I annex, I think there is at least a very strong probability that there is a rhinoceros in Papua, and the object of my letter will have been attained if it causes explorers on the north coast of that island to look after it, and at the same time places Mr. Smith's name on record as the discoverer of its indications.

"1. The heap of dung first seen, which was quite fresh (not having apparently been dropped more than half an hour), was so large that it excited Mr. Smith's curiosity, and he called Captain Moresby to see it. Neither of them knew to what animal to assign it. Quantities of dry dung were afterwards seen.

"2. Shortly afterwards, the *Basilisk* being at or near Singapore, Capt. Moresby and Mr. Smith paid a visit to the Rajah of Johore, who had a rhinoceros in confinement. Mr. Smith at once observed and pointed out to Capt. Moresby (who agreed with him) the strong resemblance between the dung of this animal and that they had seen in Papua.

"Seeing there is no animal known in Papua bigger than a pig; seeing also that Mr. Wallace has pointed out the African affinities of many of the animals in the islands he associates with Papua; seeing also that the Sumatran rhinoceros approaches the African in having two horns and no shields or folds in its hide, why should there not be a rhinoceros in Papua approaching still nearer to the African type, or furnishing an additional piece of evidence in favour of Mr. Wallace's hypothesis of a submerged continent connecting New Guinea, &c., with Africa?"

Chester, Feb. 1

ALFRED O. WALKER

### Geology and the Arctic Expedition

IN the last number of NATURE, p. 253, it is stated that the appointment of a botanist and zoologist has been recommended by the Royal Society, but it does not appear that anything is being done for geology.

It may be deemed by some an erroneous view of the matter, but I am quite disposed to believe that if the necessary arrangements can be made, geology is more likely to derive important results from this expedition than any other branch of science.

We are continually having additions to the long series of papers on the Glacial Period, but the still more remarkable *warm period* in the extreme north is altogether neglected; no one seems capable of even suggesting a probable explanation. It is quite evident, in the first place, that we want more facts, and there will probably never be a better opportunity of obtaining them than in the course of the new expedition. Carefully conducted researches would probably reveal the existence of a still further extension than has hitherto been suspected of the fossiliferous Miocene beds which have already yielded such valuable results.

Even now, it can hardly be doubted, that just before the advent of the cold period, a magnificent flora, which would require at least as much light and warmth as we now enjoy in England, was flourishing in luxuriance as far north as the 78th parallel. The contemporaneous fauna may now be discovered, and

a similar recurrence of vicissitudes of climate may possibly be detected in still earlier periods of the earth's history. These are questions of the highest interest; the forthcoming expedition may do much towards their solution, and it is to be hoped that those now directing the scientific arrangements will not neglect an opportunity of such rare occurrence.

There is nothing to be said against the appointment of a zoologist and botanist, provided geology be not neglected; but if a third addition to the scientific staff should be impracticable, it would appear preferable that a good geologist should be instructed to look after the few small plants which may be added to those already known, than that the opportunity should be lost of throwing light on a subject which is acknowledged on all hands to be shrouded in the greatest obscurity.

Birmingham

SAMUEL ALLPORT

#### Upper Currents over Areas of Frost

HAVING been for many years engaged in the discussion of upper currents, I believe that I can contribute an item of information towards the solution of the question asked by M. De Fonville in NATURE, vol. xi. p. 193.

During many of the hardest frosts experienced in the West of Europe, moist westerly winds of mild temperature prevail on the extreme southern coasts of the British Isles, and occasionally of France and Portugal; extensive areas of low pressure existing on the North Atlantic, and of high over Western and Central Europe; isobars running nearly S. and N., and gradients being steepest in the W. Under these conditions, often persistent for many days, cirrus-clouds travel almost invariably with upper currents from points between S. and W. in the extreme west, and commonly from points between S.W. and N.N.W. over the whole western portion of the area of frost.

A slight "backing" of the last-mentioned current is commonly one of the first local premonitions of the change of weather, and may often be detected by the observer before any apparent change has taken place in the atmosphere near the earth's surface, and even when the frost is temporarily becoming more intense.

But this rule is not invariable. I have several examples in which the upper current continued from N. or N.W. until the thaw had commenced; and in those instances the southerly wind, at each station as it reached it, appeared to spring up *first in the earth's surface*, and to be slowly communicated to the higher regions of the atmosphere.

And, on the other hand, the upper currents will occasionally "back," even to S.W. or S., when a local depression is advancing in the S.W. and about to pass to the S. of the observer; when, instead of a thaw, a fall of snow and an increase of frost will probably occur. Without the aid of telegraphic reports it is almost impossible beforehand to distinguish this occurrence from the advance of the general depression in the west.

On Jan. 1, 1875, the cirrus travelled from S.W. in the west, and from W. over England and France. Between this and the surface-wind were intermediate currents from S. points, of considerable velocity, and (as shown by the "silver thaw") of high temperature.

In frosts like that of Jan. and Feb. 1855, when the high pressures are in the north, cirrus travels almost invariably from W. or S. points over the area of frost.

It is remarkable that in no instance are cirrus-currents from easterly points accompanied by severe frost.

On the subject of the general laws of the upper-current circulation I cannot here enter; but I will mention, at the risk of a slight egotism, one out of many proofs of the utility of their study. Through the stormy summer of 1872, being constantly questioned by neighbours as to the probable coming weather, I posted a daily weather forecast on my door. In no instance did this prove incorrect, even as to the hour of a coming thunderstorm. And in all instances these forecasts were principally based on calculations derived from the observation of those upper currents which "weather prophets," *et hoc genus omne*, almost universally neglect.

W. CLEMENT LEY

Ashby Parva, Lutterworth, Jan. 20

#### Decomposition of Iron Pyrites

THE "curious phenomenon" described by Mr. Frederic Case (NATURE, vol. xi. p. 249) is by no means an uncommon one. It is due to oxidation, and the conversion of a portion of the pyrites into soluble sulphate of iron. This decomposition is

much aided by the presence of moisture; it is very doubtful whether it would occur at all in a dry atmosphere, and I suspect that the particular case in the Maidstone Museum, where the pyrites has thus crumbled, is near an outside wall, or otherwise exposed to humid influences. I have seen large heaps of pyrites thus decomposing at the foot of the troughs where coal-slack is washed before converting it into coke. The sulphate of iron used in the manufacture of Nordhausen sulphuric acid is commonly obtained by similar oxidation of pyrites, which is aided and economised in this case by previously roasting away a portion of the sulphur.

Mr. Case may easily test the above explanation by placing some of the crumbled pyrites in a small quantity of water, leaving it there for an hour or two, then filtering through blotting paper and evaporating the clear filtrate slowly to dryness. If I am right, he will find a residue of small crystals of sulphate of iron. A few drops on a strip of glass will be sufficient to show these crystals, if magnifying power is used; or the presence of a soluble salt of iron may be shown by adding a little ferro-cyanide of potassium to this filtered liquid.

W. MATTIEU WILLIAMS

WITH reference to a statement and inquiry put forth last week in your columns by Mr. Frederic Case, of Maidstone, respecting the decomposition of some iron pyrites, I beg to state that precisely the same effect took place with similar specimens exhibited in our museum many years ago. The cause is due, I understand, to the influence of air and moisture forming ferrous sulphate (green vitriol or copperas). In our case this salt appeared in abundant crystals, and was sufficiently strong to partially obliterate and destroy a contiguous manuscript.

Alnwick Mechanics' Institute

GEO. LINGWOOD

ON p. 249, vol. xi. is a query by Mr. F. Case as to the spontaneous decomposition of iron pyrites. I would suggest that the sulphur and iron of the mineral have been oxidised at the expense of the oxygen of the atmosphere in the presence of moisture. Some years ago I collected specimens of fossil wood, &c., from the London clay found in a deep well at the corner of Colchester Garrison. After a time my specimens were crumbling to powder, and were covered with light, silky crystals, which upon analysis proved to be sulphate of iron. Upon examining the clay minutely it was found to contain numerous golden spangles, exceedingly small, of native sulphuret of iron or iron pyrites, and the conclusion arrived at was that these spangles had absorbed oxygen and produced the crystals, and also rendered the specimens friable.

A. P. WIRE

Dunstable

#### OUR ASTRONOMICAL COLUMN

VARIABLE STARS.—(1). On the 19th of June, 1822, during the visibility of Encke's comet in the southern hemisphere, Rümker, who was then at Paramatta, N.S.W., compared the comet with a star which he judged to be between the fourth and fifth magnitude, but could not find in any of the catalogues. The sun set at Paramatta on this evening at 4h. 58m., and the comet was observed from 6h. 3m. to 6h. 46m. mean times, or from an altitude of 20° to 11°. An experienced observer as Rümker then was would not be likely to make any great error under these circumstances in estimating the magnitude of his comparison-star. Olbers in July 1824 first directed attention to it, as probably a remarkable variable star. He noted its occurrence in Harding's Chart as a seventh magnitude, and supposed it was inserted from an observation by that astronomer, who, as is well known, compared his maps with the sky; and further, he pointed out that it had been observed by Bessel in his sixty-third Zone, 1822, March 14, and then estimated also of the seventh magnitude. Rümker determined the position of his uncatalogued star, by reference to three neighbouring ones found in the "Histoire Céleste," and it agrees almost precisely with that given by Bessel's Zone. This object is No. 134 in Santini's Catalogue. (Decl.—2°), where it is again estimated a seventh magnitude. It does not occur in Argelander's

"Uranometria," but we find it in the catalogue to Heis's Atlas as a 67. In the excellent chart of the seventh hour of R.A., by Fellöcker of Kremsmünster, forming one of the series prepared under the auspices of the Berlin Academy of Sciences, we find it marked only of 8.9 magnitude. There is consequently sufficient evidence upon record to justify the appearance of this star in our catalogues of suspected variables, even if it be not considered decisive as to variability. Yet the object seems to have been generally overlooked of late years. We are nevertheless able to state that in 1873 and 1874 small fluctuations of brightness could be detected, and may recommend it to the attention of observers who are more especially interested in the variable stars. The position for the commencement of the present year is in right ascension, 7h. 23m. os., and polar distance, 91° 39'. A star of 9.10 magnitude precedes it about 4 seconds in R.A., and about 1' north. The colour is a full yellow or light orange.

(2). *Mira Ceti*, according to the formula of sines in the last catalogue of variable stars, issued by Prof. Schönfeld, will attain its maximum in the present year on February 24. The minimum determined in the manner adopted by this eminent authority will fall on September 30. The first maximum of 1876 is on January 17.

(3).  $\beta$  Cygni was indicated as variable by J. Klein, of Cologne, from a series of careful observations by himself, between July 1862 and November 1863, and Schönfeld includes the star in a provisional list prefixed to his catalogue of 1875, ascribing a variation between 3.3 and 3.9 mag. to the brighter component of this beautiful object. It is not the first time that variability has been suspected in one component only of a double star. We are able to state that last August,  $\beta$  Cygni, as a naked-eye object, certainly looked dimmer than we had often remarked it.

THE ZODIACAL LIGHT has presented itself on each clear evening since our last, but most conspicuously on the 31st ult. It was then distinctly traceable to  $\pi$  Arietis, and at best views a fainter offset appeared to extend very nearly to the Pleiades. The axis passed a few degrees south of  $\lambda$  Piscium. The intensity of light was certainly more than twice that of the Galaxy in its brightest part between the constellations Cassiopea and Cygnus.

ENCKE'S COMET.—The re-discovery of this body is not yet announced, but it will be strange if it is not detected with the larger telescopes before moonlight interferes in the evening. In 1842, when the perihelion passage occurred at the same time as in the present year, it was observed with the Berlin 9-inch refractor on Feb. 8th; much more effective instruments, however, are now common, and if the comet's constitution has remained unchanged, we might have expected observations in January.

HALLEY'S COMET.—In our "Astronomical Column," next week, we shall give the principal results of the late M. de Pontécoulant's calculation of the perturbations of this comet (so interesting, especially to English astronomers) during the actual revolution, and describe the path in the heavens which his work indicates for the year 1910.

#### ANNUAL REPORT OF THE WARDEN OF THE STANDARDS

THERE has been just issued by the Queen's printers the Eighth Annual Report of the Warden of the Standards, Mr. H. W. Chisholm, on the proceedings and business of the Standards Department of the Board of Trade.

When we remind our readers that the Standards deposited in that department have been the result of the labours of many men of science, including Davies Gilbert,

Wollaston, T. Young, Kater, Baily, Sir J. Herschel, Earl of Rosse, Lord Wrottesley, Sir E. Sabine, and lastly, but most of all, W. H. Miller and the present Astronomer Royal, we need scarcely say there should be much in this Annual Report worthy of our notice. We confine our notice here to that part of the business of this department which is most likely to interest our readers, without referring to its various official or State duties.

One part of the business of this department appears to be the conducting of comparisons and other operations with standards of length, weight, or capacity, in aid of scientific researches or otherwise. Amongst such comparisons we note the determination of the lengths of two Russian pendulums for use in the Great Trigonometrical Survey of India, in ascertaining by combined astronomical and telegraphic observations the exact position of a number of fixed points on the earth's surface. Standards were also verified for the Governments of Canada and India, for special use.

Chemists and physicists are glad to rely on the accuracy of their measures or weights, as compared with our own or foreign standards, and to be assured of the constancy of the units employed in their researches. This part of the business of the Standards Department would appear therefore to be of practical use to those whose researches require such accuracy. To maintain uniform the weights and measures of our laboratories is not only aiding individual research, but facilitating the exchange of scientific experience.

Many additional instruments are stated to have been added to the valuable collection of comparing apparatus deposited in this department: one of these is the new powerful air-pump, by Deleuil, to be attached to a vacuum balance. During the preparation of new gold and silver standard trial-plates, elaborate experiments were made by the chemist of the Royal Mint, on gold and silver alloys, reference to which is made in the special Report of the Warden of the Standards appended to the Report. These experiments are referred to more particularly in the paper by J. Norman Lockyer, F.R.S., and W. Chandler Roberts, read before the Royal Society on Nov. 20, 1873, on the quantitative analysis of certain alloys by means of the spectroscope.

Attention is called in this Report to the teaching of weights and measures in schools. There is no doubt that a large number of obsolete and unnecessary weights and measures are used in school text-books. The teaching of the metric system of weights and measures is now abandoned in schools under the authority of the Education Department.

The use of the mirror and electric lamp has been so eloquently demonstrated by Professor Tyndall, that our readers will be glad to see appended to the Report a paper on the employment of a mirror and a ray of light for indicating differences in standard weights, or in measures of length. This paper is a translation of a paper by C. A. Steinheil, read in 1867 at the Imperial Academy of Sciences at Vienna, and is a valuable record of the work of one who spent his life in scientific research.

Also appended to this Report is a short table for the reduction to 0° C. of readings of barometers with metric graduations on their glass tubes, based on those coefficients of the expansion of mercury and glass adopted in standard measurements, viz. :—

Cubic expansion of mercury . . . 0.00017971 for 1° C.  
Linear expansion of glass . . . 0.0000886 "

As an instance of the precision with which measurements are now made, we may refer to p. 40 of this Report, from which it appears that the value of a micrometer was determined at two different periods to be 0.00003181 and 0.00003183 inch respectively; showing a difference of only 0.00000002 inch. Such precision may appear to be scarcely necessary except in particular researches. As, however, any error in the production of a direct copy of

a standard is many times repeated and multiplied in the production of a weight or measure even for laboratory use, such precision is absolutely necessary in the original standards. For this reason all who value precision in their researches should take care that at least their units of measurement have been directly compared with the standards.

#### SCHREIBER'S EUROPEAN HERPETOLOGY\*

THIS volume, issued by the publishers of Blasius's well-known work on European Mammals, and illustrated in nearly the same fashion, with numerous excellent woodcuts, will be very welcome to naturalists, as supplying in a compendious form an account of an important section of the Vertebrates of our Continent, on which there has hitherto been no generally recognised authority. In England, it is true, we have Bell's "British Reptiles," if it is not out of print. But as regards the lower forms of terrestrial vertebrates, Dame Nature has, we know, treated the British Islands rather scurvily. The fact is, these cold-blooded animals cannot stand a continuously low temperature, and the ice-sheet which so recently enveloped us must have destroyed all traces of reptilian and amphibian life, so that we have only what has been received from the Continent subsequently to the "Great Ice Age." And this is the reason of our scanty allowance. Europe generally, as we shall see from Dr. Schreiber's pages, is much more liberally furnished with representatives of these two orders of vertebrates.

Dr. Schreiber commences his work with an account of the European Amphibians, which naturally fall under the two sections *Urodela* and *Anura*. Of the Urodela, or Tailed Amphibians, two families are recognised, one containing only the abnormal form *Protetis*, the other the Salamanders, which are divided into seven genera, containing altogether fifteen European species. The tailless division of the order, which comprehends the frogs and their allies, is not quite so numerous, only twelve species being recognised as European, which are assigned to eight genera. The account of these animals is followed by a very interesting chapter on their distribution, accompanied by many illustrations of it in a tabular form. Genera and species of Amphibians are alike most abundant in the south. While England only has eight species belonging to three genera, Germany has fifteen belonging to eight, and France twenty-one distributed amongst nine genera.

The second and larger division of Dr. Schreiber's work treats of European reptiles, beginning with the Snakes and proceeding through the series of Saurians to the few European representatives of the order of Chelonians. As in the former section, each species is well described, and particulars are given as to its distribution and habits. The variations in form and colour, which in some of the lizards and snakes are very numerous, are likewise given, and the mean seems to have been preserved between recognising too many species on the one hand, and allowing too few on the other. Altogether, twenty-four snakes, thirty-five lizards, and five tortoises (sixty-four reptiles in all) are treated of as occurring within the limits of the Continent of Europe. A full treatise on the range and distribution of these sixty-four animals is appended to this portion of the volume, which is concluded with remarks upon the collection, preparation, and transmission of specimens of these animals. On the whole, we can cordially recommend Dr. Schreiber's work as an excellent handbook and work of reference for those who are interested in this branch of natural history.

\* Herpetologia Europæa, eine Systematische Bearbeitung der Amphibien und Reptilien welche bisher in Europa aufgefunden sind. Von Dr. Egid Schreiber, Director an der Oberrealschule zu Görz, Braunschweig, F. Vieweg und Sohn, 1875. 1 vol. 8vo., 64 pp., and numerous woodcuts.

#### BOTANY IN QUEENSLAND

IN his last report on the Brisbane Botanic Gardens, Mr. Walter Hill, the director, gives some interesting details on the progress of the garden, and more especially with regard to his trip to the Bellenden Kerr range, on the north-east coast of Queensland, in November last. Looking at the garden in a utilitarian point of view, rather than as a place of recreation and enjoyment—for which purposes, however, it is largely patronised—we find that the experimental department still continues to prove its utility in the introduction and distribution of plants yielding products of commercial value; frequent application is made for plants yielding fibres, medicinal products, dyes, &c.; more especially among this group of plants are applications made for indigo for the planters upon the northern rivers. Mr. Hill thinks that the growth and manufacture of indigo will probably assume the proportions of valuable and important interest in the tropical regions of the colony, whenever labour can be obtained at a sufficiently cheap rate. The experimental coffee plantation has proved very satisfactory during the past year, and the demand for sugar-cane continues, trials in its cultivation having succeeded in several previously untried localities. Amongst other economic plants distributed for experimental cultivation in Queensland may be mentioned the olive, tea, palm oil, lavender, senna, medicinal rhubarb, cocoa, clove, cinnamon, nutmeg, vanilla, ginger, &c. That trials in the acclimatisation of many of these valuable economic plants are intended in earnest will be understood from the following extract from the report. Mr. Hill says: "I would beg to call attention to the expediency of setting apart 400 acres upon both the Johnstone and the Daintree rivers, these districts offering better advantages as regards aspect and soil than the reserve at Cardwell possesses for the cultivation of the Clove (*Caryophyllus aromaticus*), the Nutmeg (*Myristica moschata*), the Vanilla (*Vanilla aromatica*), the Cocoa (*Theobroma cacao*), the Coca (*Erythroxylon coca*), the Mangosteen (*Garcinia mangostana*), the Durian (*Durio zibethinus*), the Bread Fruit (*Artocarpus incisa*), &c., which require some more degrees of heat and moisture to bring them to perfection than can be had at Cardwell. In fact, with the vast variety of climate and soil of Queensland, it must of necessity be the case that each locality has a distinct description of vegetation most suited to it."

With regard to the ascent of Bellenden Kerr, we are told that the first two miles of the course led through low ground, which, after much wet weather, must become a swamp. The vegetation consisted of *Barringtonia carya*, F. Muell., *Ptychosperma alexandria*, F. Muell., *Calamus australis*, Mart. (Lawyer Cane), *Bambusa arundinacea*, Retz., *Pandanus aquaticus*, F. Muell.; whilst on the higher portion of the ground were *Wormia alata*, R.Br., *Dysoxylon oppositifolium*, F. Muell., *Aglaia elaeagnoides*, Benth., lawyer cane, bamboo, screw pines, &c. A fine watercourse was here crossed, which was referred to as the Bellenden River. Along the banks of this river the trees consisted of the genera *Castanospermum*, *Eugenia*, *Brucea*, *Ximelia*, *Elaeocarpus*, *Owensia*, &c. The soil on both sides was of a sandy nature, with a good admixture of vegetable matter. It took about three hours to reach this place, the distance of which was calculated at about three miles from the point of departure, and having risen, according to the aneroid, to an elevation of 160 ft. Having found a spur, four hours and a half were consumed in covering a distance of one mile and a half, through a complete mass of bamboos, lawyers, and screw pines, where the exploring party camped for the night on a small incline between two ridges, at an elevation of only 1,250 ft. The trees in this neighbourhood consisted of *Erioglossum edule*, Bl., *Cupania Robertsonii*, F. Muell., *Atalaya salicifolia*, Bl., *Harpullia Leichardtii*, F. Muell., *Castanospermum australe*, A. Cunn., *Mimusops parvifolia*, R.Br., *Achras pohlmanniana*, F. Muell. The thic

growth of the Pandanus was not one of the least obstacles encountered in the ascent. One tree fern (*Alsophila Rebecca*, F. Muell.) and a climbing fern (*Gleichenia Hermannii*, R. Br.), which runs up to a height of 50 or 60 ft., were so abundant that in some places a way had to be cut through them. *Alsophila Rebecca* was occasionally so much entangled with other plants, such as *Smilax elliptica*, R. Br., *Flagellaria indica*, Willd., &c., that to penetrate them was a work of extreme difficulty.

The top of the range is 5,300 ft. above the sea-level, and in clear weather, considering its situation, the surrounding scenery must be very fine; at the time Mr. Hill and his party visited it, however, everything below was hidden by mist. Though the main purpose of the expedition was the exploring of a certain portion of the north-east coast of Queensland with the view of ascertaining the adaptability of the soil for cultivation, the result was not without interest in a botanical point of view, namely, the discovery of new plants. Mr. Hill records two new palms, discovered at an altitude of 2,000 ft., one of which was a beautiful plant about 20 ft. high, with leaves or fronds about 20 ft. long, and a stem about 9 in. in diameter; the other grew about 12 ft. high, and its stem was about 3 in. in diameter; this appeared to be a species of *Kentia*. A fine proteaceous tree about 60 ft. high, with splendid crimson flowers, was seen at 2,500 ft., and at 500 ft. lower down a beautiful new orchid, a species of *Anactochilus*, was discovered. Besides these, other new plants of more or less interest were seen, which in course of time will no doubt find their way to this country.

It is not so very long since Baron Mueller recorded the discovery of some colossal trees of the Eucalyptus group in the back gullies of Victoria, trees that rivalled, and even exceeded, in height the largest known Wellingtonia. Now Mr. Hill tells us of a splendid *Dammara* tree passed by him in his descent from the top of the range, the height of which he roughly estimated at not less than 120 ft., with a trunk 4 ft. through. *Dammara robusta*, C. Moore, is the only species at present recorded in Australia, and this is found rather abundantly in the Queensland forests, and is stated to grow to a height of 150 ft., so that in the matter of height the tree seen by Mr. Hill does not exceed any previously known, but a trunk 12 ft. in circumference is not a small tree.

We hope that Mr. Hill will be enabled to make a further exploration of this part of Queensland, and publish the account of his journey in a more detailed form.

JOHN R. JACKSON

#### THE TOCK-TAY, OR LARGE HOUSE LIZARD OF EASTERN BENGAL

THIS noisy but harmless animal generally finds a lodgement in the bamboo and mat houses of the district that are anywhere near the jungle. It is also fond of living in hollow trees, which give great resonance to its loud and strongly staccatoed cry of *tock-tay*. It is of a green tint, mottled over with red spots, and suckered feet like its smaller congener, the Tick-ticke, enable it to run under beams and bamboos. Its cry is, however, very different from the gentle *tick-tick* of the small lizard, being sufficient at night to awake the soundest sleeper. He begins with a loud rattle as if to call attention; this is followed by another and more imperative rattle, and when everybody may be supposed to be listening, he strikes in deliberately with *tock-tay*—a moan—*tock-tay*—another moan—*tock-tay*—a last and final moan, with which he winds up, not to be heard again for an interval.

In the way of edibles he is fond of a good crust, and the common dung-beetle frequently furnishes him with a *pièce de résistance*. That insensate insect becomes an easy prey, owing to his heedless rattle-dum-clash ways; he is the

great extinguisher of lights at night in native houses, and Europeans are also familiar with his strong sustained drone, varied by intervals of silence when he has dashed against some rafter or projection, or given himself a heavy fall; but he is not to be discouraged, and is soon up and droning about as dismally as ever.

The drone, however, is sometimes suddenly quenched without the consequent thump on the floor, and when this is followed by a crunching sound overhead one may safely infer that it is Tock-tay who has been lying in wait for him and has snapped up his prey.

These lizards may easily be caught during the day by slipping a noose over their necks while they are asleep in an exposed position; and when so caught they snarl, growl, and snap at their captor in a very ferocious way. I have not heard, however, that they are venomous.

C. B.

#### NOTES

THE cause of Technical Education is already much indebted to Sir Joseph Whitworth, who has just added to his former judicious benefactions by proposing to found, in connection with Owens College, Manchester, King's College, London, and University College, London, a certain number of Whitworth Exhibitions, in order to fit young men having a mechanical instinct and some little experience better to become candidates for the Whitworth Scholarships. Competitors for these exhibitions must comply with certain reasonably easy conditions, and the successful competitors will be entitled to receive during the two years next following the examination, instruction in all such subjects (being part of the course of each College) as shall better prepare them for the Whitworth Scholarship Examination—viz., practical plane and solid geometry, machine drawing, mathematics, theoretical mechanics, applied mechanics, and freehand drawing. Sir Joseph Whitworth will pay each College annually for four years, as a trial of the success of his proposal, the sum of 100*l.* for or towards, at the option of each College, the academical expenses of the exhibitioners.

THE Cambridge Mathematical Tripos has been published; it contains this year eighty-six names, of whom twenty-eight are Wranglers, thirty-four are Senior Optimes, and twenty-four Junior Optimes. The Senior Wrangler is Mr. John William Lord, of Trinity College, a son of the Rev. Isaac Lord, of Walton, near Ipswich, lately a Baptist minister in Birmingham. He was educated at Cambridge House, Birmingham, then at Amersham Hall School, near Reading. In 1868 he obtained honours at the matriculation examination of the University of London. At the examination for M.A., in June 1874, he was awarded the gold medal for mathematics. In 1870 he entered Trinity College, Cambridge, when he was awarded an open scholarship for mathematics, and subsequently was elected a foundation scholar. He was declared equal in merit for the Sheepshanks Astronomical Exhibition with Mr. Lewis, of Trinity College. The Rev. E. W. Blore was his college tutor, while he received private tuition from Mr. E. J. Routh, of St. Peter's College. Mr. Lord was distinguished as an athlete, and regularly rowed in his College boat.

THE Minister of Finances of France has at last consented to pay into the hands of M. Eichens the money which he required to begin the construction of the meridian telescope presented by the banker Bishofsheim to the Paris Observatory. M. Leverrier's letter noticing the fact was gazetted. The financial rules of the French Administration are so stringent that they could not be altered for the defence of the country during the Franco-German war; consequently it is an indication of the growing spirit of the times to see they are no longer available for obstructing the path of science. The opposition of the Minister to the payment of

the 1,300, which had been placed in his hands by M. Bishofshelm for certain purposes had attracted much notice, and the end of the difficulty has created quite a sensation.

THE Observatory of Paris is to give a series of *soirées* on the first Monday of each month. Instruments will be placed at the disposal of visitors for observing celestial phenomena, and the most important inventions will be exhibited and explained.

THE method of electing the President of the French Academy of Sciences is very peculiar. In the beginning of January each year a member is nominated Vice-president for the year, and becomes President the following year without being re-elected. The appointment is made alternately in the classes of Physical Science and Mathematics. It being the turn this year of the latter section, Admiral Paris has been elected Vice-president and will be President for 1876. The President actually in office is M. Frémy, the celebrated chemist. M. Paris was born at Brest in 1806, and his first voyage was on board the *Astrolabe*, in which he circumnavigated the globe, under Dumont d'Urville, in 1826. He lost his left hand at Pondicherry in 1837, when visiting a factory. He has written many books on steam navigation, and is a member of the Navigation Section of the Academy. He was created an admiral in 1858.

THERE exist in the largest French provincial towns local Academies, the proceedings of which seldom attract attention beyond their immediate vicinity; but they never lose an opportunity of following the lead of the Academy of Sciences of Paris. The Paris Academy having appointed M. Bertrand successor to M. Elie de Beaumont, as perpetual secretary, the Academy of Toulouse shortly afterwards sent to M. Bertrand a brevet of membership to fill the place vacated by the demise of his predecessor. As M. Elie de Beaumont was a member of the Academies of Lyons, Bordeaux, Marseilles, &c., M. Bertrand has a very good chance to acquire without moving all the academical honours which belonged to his predecessor, except in the cities where he was himself previously a local academician.

THE annual conference for regulating the operations of the Mint in connection with international coinage was held recently at the French Foreign Office, Paris. Except Greece, representatives of all the other nations who are parties to the international convention for the inter-circulation of decimal coins, were present. The system extends now to France, Italy, Belgium, Switzerland, and Greece. No measures of importance were passed, but it is supposed that some useless restrictions on coinage will be abolished in 1876.

THE *Kölnische Zeitung* of Jan. 19 contains a letter from the celebrated African traveller, Dr. G. Schweinfurth, from which we learn that, by order of the Khedive of Egypt, Herr Rohlf's has distributed among a number of eminent personages, scientific societies, and men of science, one hundred albums, magnificently got up, and containing a collection of fifty large photographs of the Libyan Desert, by Remelé, of Gastendonk, near Aldekerk. Remelé accompanied Herr Rohlf's expedition of last winter into the deserts of Africa, and has, for the first time, photographed landscapes of the district mentioned in a highly artistic manner. Whoever knows the different characteristics of the African climate compared to the European one, will understand that considerable skill was required to produce real works of art under such altered conditions. It is to be regretted that the handsome collection cannot be obtained by purchase: only a few favoured ones can derive from it that enjoyment that every lover of nature would naturally experience from photographs so highly interesting.

WE learn from the *Kölnische Zeitung* that on January 20 the first meeting of the Italian division of the International

Commission for the Measuring of the Meridian took place at the Military Topographical Office at Naples. The members are General de Vecchi (president), General Ricci, Major Ferrero (secretary), the astronomers De Gasparis (Naples), Respighi (Rome), Santini (Padua), Schiapparelli (Milan), and Professors Betocchi, Schiavoni, and Oberholtzer. The meeting, in making out the programme for 1875, continued the work begun at the autumn meeting at Dresden.

In reference to the proposed Channel Tunnel between France and England, we may refer our readers to *NATURE*, vol. i., pp. 160, 303, 631, and vol. x., p. 181, where the scientific bearings of the subject are pretty fully discussed. While on this matter we may state, on the authority of *La Nature*, that there has been in existence for some time in Spain an Inter-continental Railway Company, whose object is to connect Europe and Africa by a tunnel underneath the Straits of Gibraltar, the maximum depth of which is 819 metres.

DR. COUES has published, in the Proceedings of the Philadelphia Academy, a synopsis of an elaborate work by him upon the mice of North America, based upon the many thousands of specimens in the Smithsonian Institution. In this he considerably reduces the alleged number of species, although describing some that he considers new.

DR. REGEL, in an appendix to the second fascicule of his "Descriptiones" plantarum novarum et minus cognitarum in regionibus Turkistanicis, etc., collectis," defends his theory of the descent of the grape-vine of the Old World, in its numerous varieties, from *Vitis labrusca* and *V. vulpina*, two New World species, the former extending to Japan. *V. parvifolia* and *lanata* of Roxburgh, Indian species, he identifies with the foregoing, and thus traces out the relationship of the grapes of the Old and New Worlds. Although Dr. Regel can see his way to this extreme of variation, he still holds fast to the opinion that "the specific limits of any species whatsoever were called into existence (or defined) with the appearance of the first individual of that species, and that there is no gradual evolution from the lower to the higher organisms.

A SECOND EDITION of Hooker's "Synopsis Filicum" has just appeared. It will be remembered that the late Sir William Hooker left the original work unfinished, and that it was taken up and completed by Mr. J. G. Baker. The second edition has also been prepared by the same gentleman. A period of about six years has elapsed since the first publication, and the edition before us contains four hundred additional species. The idea of a species as developed in this work is very broad and comprehensive; hence this number represents nearly as many distinct new forms, very few coming under the denomination of "critical species." The total number of species admitted now exceeds 2,600. The additional species are given in an appendix occupying seventy-seven pages. In the body of the work a number of bad species have been reduced to their respective types, and their places taken by new species. A relatively large proportion of the new species are tree-ferns—*Cyathea*, 25; *Hemitelia*, 11; *Alsophila*, 25; and *Dicksonia*, 13; and there are no fewer than sixty new species each of the new genera *Polypodium* and *Nephrodium*, in the extended sense given to them in this work. *Asplenium* is represented by about fifty new species. Only one new genus is given, *Diplora*, an asplenoid form from Solomon Islands, bringing the total up to seventy-six. Whether the generic and specific limits adopted in this work be accepted or rejected, the book is indispensable to all pteridologists. We may mention that the complete index has been issued in a separate form, which will be very useful to all lovers of ferns and horticulturists generally.

AN account has reached us of the Memorial Meeting of the Boston Society of Natural History, on the 7th of October, 1874, held to mark the death of Dr. Jeffries Wyman in September



last, of whose life we gave some account shortly after. The principal address at the meeting was by Prof. Asa Gray, who sketched Dr. Wyman's life and his work as a biologist. Prof. Gray speaks in very high terms of Dr. Wyman's work. In the memoir on *Tragodytes Gorilla*, read before the Boston Society in 1847, and of which the osteology and introductory history is by Dr. Wyman, and in the subsidiary papers, Prof. Gray says, "may be found the substance of all that has since been brought forward, bearing upon the osteological resemblances and differences between man and apes."

We note the receipt of the Annual Report for 1873 of the Birmingham Natural History and Microscopical Society, one of the most energetic of this class of societies in the kingdom. There is a very interesting address by the retiring president, Mr. W. R. Hughes, F.L.S., in which he reviews briefly the recent progress of the study of Marine Zoology. We are glad to see that the Society contemplates going so far afield on an exploring excursion as the Mediterranean; our readers may remember that in the autumn of 1872 they made a very successful dredging excursion to Teignmouth. Mr. Hughes suggests that the Birmingham and similar societies should combine in a petition to the proper quarter to obtain any surplus specimens from the *Challenger* collection which may remain after the British Museum and other headquarters for specimens have been supplied. The suggestion seems to us a very reasonable one, though it may be found that after all the *Challenger* specimens will not go very far in this respect. We are glad to see that the Society continues to be increasingly prosperous.

We are gratified to learn that a Natural History Society and Field Club was successfully inaugurated at Watford on the 23rd ultimo. It has commenced with about fifty members, ladies and gentlemen, and Mr. J. Hopkinson was appointed secretary. We wish the Society every success; it is the only one of the kind in Hertfordshire, and we hope it will set itself in earnest to extend and complete our knowledge of the natural history of that county.

PROF. HAYDEN has lately printed a catalogue of the publications of the United States Geological Survey under his charge, filling a pamphlet of twenty pages.

IN the number of the *Pharmaceutical Journal* for Jan. 23, Mr. E. M. Holmes throws considerable light on the botanical source of the new drug Jaborandi. Prof. Baillon was the first to refer it to a species of *Pilocarpus*, but upon very insufficient materials. Mr. Holmes, however, has succeeded in obtaining better specimens, including some ripe fruits, and from these he arrives at the conclusion that there are two or more distinct varieties of the drug, one of which is very near if not identical with *Pilocarpus pennatifolius*, Lem., another from a species of the same genus not yet known, and another still from a species of *Piper*. These are now in use both in France and England, but several other plants possessing similar properties and known under the same name of Jaborandi are in use in South America. With regard to its physiological action, Mr. Martindale contributes some interesting notes in the *Pharmaceutical Journal* for Jan. 16.

The *Journal of the Society of Arts* quotes an article from the *Journal de la Société d'Horticulture* on indiarubber-producing plants. This paper is a résumé of well-known facts relating to these valuable plants, the only point of interest being in connection with the Central American Caoutchouc Tree, *Castilleja elastica*, Cerv., which, we are told, in the district of St. John, in Nicaragua, furnishes employment to from 600 to 800 persons, in extracting off the juice. In the neighbourhood of Panama about 2,000 persons are so employed.

SOME official correspondence relating to the conservation of the Government forests in Ceylon has been published in Colombo,

from which we learn that a good deal of Satin Wood (*Chloroxylon swietenia*), Calamander (*Diospyros quercita*), and Ebony (*Diospyros ebenum*), exists in the forests, and that the system of felling trees by the natives for firewood and other uses, though illegal, is still carried on to some extent, many of the natives being quite ignorant of forest reservation, while others are such adepts at stealing that the forest officers are not sufficiently numerous to prevent it.

COL. PLAYFAIR, the Consul-General of Algeria, reports that the cultivation of the vine in that country is becoming yearly of greater importance, the advance in the prices of wine in France having given a greater impetus to its cultivation in Algeria. The Sahel, which comprises an area of 125,000 acres, is especially suited to the vine culture, and it is anticipated that this space will some day be nearly covered with the plant. At the time of writing the report, Consul Playfair says, the Phylloxera had not reached Algeria, and the importation of vine-cuttings from any part of Europe was rigorously prohibited.

MR. J. M. WILSON, of Rugby, writes (Jan. 29), with reference to Antares:—

"The subjoined measures may interest the readers of the astronomical column in NATURE, vol. xi. p. 249. I will measure it again soon:—

Position.	Distance.	Date.
268°7	3'46	73'42

THE additions to the Zoological Society's Gardens during the past week include a Clouded Tiger (*Felis macroclis*) from Burma, purchased; an Azara's Fox (*Canis azarae*) from South America, presented by Mr. J. Williamson; a Common Paradoxure (*Paradoxurus tybus*), a Bonnet Monkey (*Macacus radiatus*), and a Macaque Monkey (*M. cynomolgus*), all from India, presented by Mr. D. D. Abbott, Miss S. Melley, and Mr. F. G. Lane respectively.

#### DETERMINATION OF THE VELOCITY OF LIGHT AND OF THE SUN'S PARALLAX\*

I HAD the honour to submit to the Academy various improvements relating to the method devised in 1849 by M. Fizeau for the direct determination of the velocity of light. These improvements, tried upon a moderate distance (10,310 metres between the Ecole Polytechnique and Mont Valérien,  $V = 298,500$  kilometres, probable error below 0'01), entirely succeeded, and permitted me to affirm that the improved method was capable of giving results of great precision under the conditions of operating at a greater and better determined distance and employing more powerful apparatus.

The preparations of the expedition for observing the Transit of Venus drew the attention of astronomers to the utility of a precise determination of the velocity of light, for this velocity combined with certain astronomical constants allows the calculation of the sun's parallax, of which the direct observation demands such laborious voyages and the devotion of many astronomers. Thus, at the suggestion of M. Le Verrier, director of the Paris Observatory, and of M. Fizeau, member of the Council, the Council of the Observatory decided at the commencement of 1874 that a determination of the velocity of light should be undertaken without neglecting anything that could give to the operation all the desirable precision.

The Council did me the honour of confiding to me this important operation. Much honoured by and very happy at this decision, I should nevertheless have hesitated to accept so grave a responsibility had I not been strongly encouraged by M. Fizeau, who has not ceased during the whole duration of the labour to offer me the most liberal and precious advice.

After a searching examination of various stations I adopted the Observatory and the tower of Monthéry, distant about 23 kilometres. I was guided in this choice by the consideration

\* Translated from a paper read by M. A. Cornu before the Paris Academy of Sciences.

that the value of the distance of these two points is beyond the pale of all discussion. In fact, their position has been determined or verified by the most eminent observers, especially on the occasion of great geodesic works and of the measure of the velocity of sound undertaken by the Academy in the last century, at the time of the meridian operations, of the determination of the metre, of the map of France, and of the new measure of the velocity of sound made by the Bureau des Longitudes. These two stations are thus in a manner classic, and are bound up with the most glorious memories in the history of French science.

The experiment was installed in conditions worthy of the importance of the problem to be solved. The emission telescope has not less than 8.85 metres focal distance, and 0.37 m. aperture. The mechanism of the toothed wheel permits a velocity of the latter exceeding 1,600 revolutions per second; the chronograph and electric recorder ensure the measurement of time to the thousandth of a second. M. Bréguet, to whom the construction of these pieces of mechanism had been confided, has brought to bear upon their execution that devoted co-operation which he has always given to all the operations with which his name is associated.

All the apparatus is firmly fixed on the superior terrace of the Observatory; an electric communication, establishing the correspondence of the chronograph with the beatings of the pendulum of the meridian chamber, fixes the unit of time with the greatest precision. At the opposite station, on the summit of the Montlhéry tower, there is but a reflecting collimator, of which the objective is 0.15 m. in aperture and 2 m. focal distance; it is surrounded by a large cast-iron pipe, fixed into the wall, in order to secure it from the curiosity of visitors.

The description of the apparatus and of the method of observation will form the subjects of a detailed memoir. I will only recall now the principle of the method. A beam of light is sent across the teeth of the moving wheel, which beam is reflected from the opposite station. The luminous point which results from the return of the rays appears fixed, notwithstanding the interruptions of the beam, owing to the persistence of the impressions upon the retina. The experiment consists in ascertaining the velocity of the toothed wheel, which extinguishes this *luminous echo*. Extinction occurs when, in the time necessary for the light to traverse double the distance of the stations, the wheel has substituted a tooth for the interval between two teeth which permitted the passage of the light at starting, so that the extinction of the order  $n$  corresponds to the passage of  $2n - 1$  semi-teeth during this short space of time. The law of the motion of the mechanism which moves the toothed wheel inscribes itself on a smoked cylinder, and the observer, by an electric signal, records the precise moment when the necessary velocity is attained.

The observations are thus preserved as tracings, which I have the honour to submit to the inspection of the Academy.

The following is a summary of the results obtained from 504 experiments, which I have sought to vary by diversity of wheels, by the number and form of the teeth, as well as by the magnitude and direction of the rotation. These results represent the velocity of light in air expressed in kilometres per second of mean time; they are arranged according to the order  $n$  of the extinction which determined them; the number accompanying them represents their *relative weights*, that is, the product of the number of observations into the factor  $2n - 1$ .

	$n=4$	$n=5$	$n=6$	$n=7$	$n=8$
$V$ ... ..	300,130	300,550	300,750	300,820	299,940
$k \times (2n-1)$ ...	15 $\times$ 7	33 $\times$ 9	20 $\times$ 11	10 $\times$ 13	7 $\times$ 15
	$n=9$	$n=10$	$n=11$	$n=12$	$n=13$
$V$ ... ..	300,550	300,640	300,350	300,500	300,340
$k \times (2n-1)$ ...	94 $\times$ 17	69 $\times$ 19	72 $\times$ 21	3 $\times$ 23	4 $\times$ 25
	$n=14$	$n=15$	$n=16$	$n=17$	$n=18$
$V$ ... ..	300,350	300,290	300,620	300,000	300,150
$k \times (2n-1)$ ...	9 $\times$ 27	65 $\times$ 29	4 $\times$ 31	22 $\times$ 33	35 $\times$ 35
	$n=19$	$n=20$	$n=21$		
$V$ ... ..	299,550	300,060			
$k \times (2n-1)$ ...	6 $\times$ 37	36 $\times$ 36			

The agreement of these numbers is as close as can be desired in experiments of such difficulty, and which the least undulation of the atmosphere can hinder; it is true that I always awaited a purity and exceptional calmness of the atmosphere to make these measurements, my patience being thereat much tried, but owing to this precaution the series have always been very regular. It is necessary to add, that in no case can atmospheric disturb-

ances be the cause or systematic errors, for their occurrence is always fortuitous, and on the mean of a large number of observations their influence is *nil*.

The experiments were made at night by means of the Drummond light, with the exception of the series of the fifteenth order, which, by an exceptionally favourable meteorological circumstance, were able to be performed by day with sunlight. Notwithstanding the difference in the nature of the luminous source, the result does not deviate from the mean.

The mean of all these values, having regard to the importance of each group, is equal to 300,330, which, multiplied by the mean refractive index of air (1.0003), gives as definite result the velocity of light *in vacuo*,  $V = 300,400$  kilometres per second of mean time,\* with a probable error below one-thousandth in relative value.

From this the solar parallax is deduced in two different manners.

1. *From the equation of light*.—It is thus that was designated in the last century the time  $\theta$  which the sun's light takes to traverse the mean radius  $R$  of the terrestrial orbit. The reduction of more than a thousand eclipses of Jupiter's satellites gave Delambre  $\theta = 473.2$  mean seconds. Calling  $\epsilon$  the parallax of the sun and  $\rho$  the equatorial radius of the earth ( $\rho = 6378.233$  km.), we have obviously  $R = V\theta$ ,  $\rho = R \tan \epsilon$ , whence  $\tan \epsilon = \frac{\rho}{V\theta}$  and  $\epsilon = 8''.878$ .

2. *From the aberration of light*.—Bradley, who discovered this phenomenon, found for the annual semi-elongation  $\alpha$  of an ideal star situated at the pole of the ecliptic (elongation due to the composition of the mean velocity  $u$  of the earth in its orbit with the velocity of light  $V$ ), the value  $\alpha = 20''.25$ . According to W. Struve this number ought to be increased to  $20''.445$ . The equation of condition, designating by  $T$  the duration in mean seconds of the sidereal year ( $T = 365.26 \times 86400$ ), will be:—

$$\tan \alpha = \frac{u}{V} = \frac{2\pi R}{VT} = \frac{2\pi \rho}{VT \tan \epsilon}$$

whence

$$\tan \epsilon = \frac{2\pi \rho}{VT \tan \alpha}$$

By substituting  $\alpha = 20''.25$  we deduce  $\epsilon = 8''.881$ ; with  $20''.445$  we get  $8''.797$ . The agreement of the two methods is complete if we adopt Bradley's number.

I will recall the fact that Foucault had, by the method of a revolving mirror, found for the velocity of light the number 298,000 km., but with an indeterminate approximation, and by combining this value with Struve's constant he concluded  $8''.86$  to be the value of the solar parallax.

The study of the planetary perturbations leads to a value for the solar parallax which still further increases the interest of this agreement. I will specially cite the profound study of the perturbations of the motions of Venus and Mars made by M. Le Verrier, and which has led to the following numbers:  $\epsilon = 8''.853$  by the consideration of the latitudes of Venus at the moments of the transits of 1761 and 1769;  $\epsilon = 8''.859$  by the discussion of the meridian observations of Venus in an interval of 106 years; finally,  $\epsilon = 8''.866$  deduced from the occultation of  $\psi$  Aquarii, observed by Richer, Picard, and Roemer on the 1st of October, 1672; the mean of these values gives  $8''.86$ .

To summarise, the methods which serve in astronomy to determine the parallax of the sun can be classed into three groups:—

1. *Physical methods*, founded on the observation of an optical phenomenon; they comprise the observation of the eclipses of Jupiter's satellites, or the aberration of the fixed stars, combined with the value for the velocity of light deduced without the intervention of other astronomical phenomena; the present work permits us to profit by the observations which are the basis of the method: the results are,  $\epsilon = 8''.88$ ,  $8''.88$ ,  $8''.80$ . Mean,  $8''.85$ .

2. *Analytical methods*, which depend on the comparison of astronomical observations with theoretical laws founded on the principle of universal gravitation: they give, as we have just seen, values near  $8''.86$ .

3. *Purely geometrical methods*, depending on the parallactic displacements of the planets near the earth: the oppositions of Mars furnished, in 1862,  $\epsilon = 8''.84$ . But the transit of Venus across the sun is the phenomenon in which the geometrical method can attain the greatest precision.

\* The velocity in English miles per mean second will be 186,700.

Thus we see what interest there is for astronomy to determine the parallax of the sun by three independent methods; I trust that the experiments that I have the honour to submit to the Academy will justify, by their precision, the theoretical importance of the physical method. R. M.

### ON THE MUSCULAR MECHANICAL WORK DONE BEFORE EXHAUSTION\*

#### II.

ONE of the principal sources of error in the series of experiments before discussed, was the fatigue caused by the downward-plunging weight. To eliminate this, the apparatus shown in vertical section in Figs. 1 and 2 was constructed. The shelf *a*, armed with a plate of car-spring caoutchouc, serves as a support for the weight. This shelf is fastened by the iron bands, *b*, and a vertical backpiece, *B*, to the slide, *u*, being further supported by a crosspiece. By suitable blocks, *a*, the slide may be raised to any desired height, which height is read off on a scale marked on the upright pieces, *A*. *s* is a support for the arm during the interval of rest, and it can be adjusted to any desired height; *W* is a wire, from which a small cord, *b*, passes horizontally to the wall of the room. By some modifications this cord can also be made movable, which will become necessary when I come to investigate the influence of elevation of the arm, upon the work done. The weight is a bucket of shot, provided with a stiff bail and a wooden handle, so that for any position of the arm while lifting the weight, the line passing through the centre of the hand and the centre of gravity of the weight is a vertical. Placing the bucket upon the shelf *a*, the experimenter stands to



FIG. 1.



FIG. 2.

the right of the apparatus (as in Fig. 2), and lifts the weight until his knuckles touch the cord *b*. The instant of beginning and close of this interval of work is marked by the sharp click of a metronome, the time of whose beat is *t*. At the instant when the knuckles touch the string, the weight is grasped by an assistant, † and by him lowered to the shelf *a*, the arm of the experimenter being entirely relaxed, and resting upon the stiff bail of the bucket and the support *s*. ‡ This is continued until the arm becomes unable to lift the weight to the required height. The determination of the number of lifts should never be made by the experimenter, who should furthermore try to lose all estimate of time during the process. In the earlier experiments it became evident that the arm not only grew gradually stronger, but also that it varied greatly from day to day. In order to get some measure of the strength, the arm was exhausted on each day of experiment, by a constant weight (5.0 kilos.) lifted through a height *h* = 0.70 metres in a time  $\tau$  = 1.25 sec. The values of

\* Continued from p. 257.

† I am under many obligations to friends, among whom I may mention Mr. W. C. Preston and Mr. D. A. Myers, for aid in this very laborious work.

‡ The arm is raised in the plane which make an angle of 45° with the vertical plane passing through the centres of the shoulder-joints.

*n* were all reduced to the mean strength, as shown by the constant experiment.

In the series here given, *w* was variable, *h* = 0.70 metres, and  $\tau$  = 1.25 sec., the interval of rest being equal to the interval of work. The mean value of *n* for the constant experiment for the weights *w* = 3.0, 3.5, 4.0, &c. — 7.5, in all 100 experiments, is 35.79. Taking these values, *c*, as the measure of the strength, and assuming that the work done with any weight at different times is proportional to the strength,\* and we have—calling *n'* the number of lifts before exhaustion, and *n* the number reduced to the basis of the mean constant (35.79)—

$$n = \frac{35.79}{c} n'$$

from which we have the following values of *n*, which hereafter we shall call *n* (obs.). Each of these values is a mean of ten independent determinations.

TABLE II.

<i>w</i>	<i>n</i> (obs.)	<i>n</i> (calc.)	<i>dn</i>	<i>c</i>
2.50	28.3	24.2	-14.4	7.5
3.00	152.5	150.3	- 1.4	3.7
3.50	95.8	99.4	+ 3.6	3.6
4.00	67.2	69.2	+ 2.0	2.9
4.50	51.2	50.1	- 2.1	3.3
5.00	36.9	37.4	+ 1.3	2.4
5.50	28.6	28.7	+ 0.3	2.0
6.00	22.7	22.5	- 0.9	1.3
6.50	18.1	18.0	- 0.5	1.1
7.00	14.5	14.6	+ 0.7	0.7
7.50	10.4	11.9	+14.4	0.9
8.00	7.7	9.9	+28.5	5.2

The determination of *n* for *w* = 7.5 and 8.0 was consciously bad, as the arm was unable to manage such weights at such a

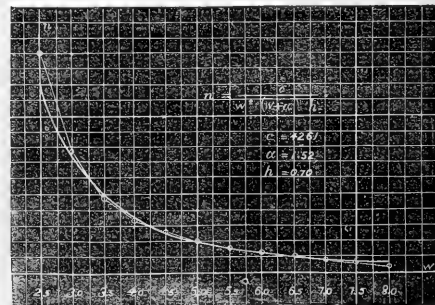

FIG. 3.

velocity, so that I was obliged to stop before the arm was exhausted.† The values of *n* for *w* less than 3.0 were also dropped in the final calculation, as with such light weights the work is found to vary greatly with a slight variation of strength.

Assuming the arm to be a uniform cylinder, and denoting by *a* one half the weight of the arm, and we have as the dynamical work done before exhaustion—

$$W = (w' + a) h n \quad (6).$$

The value of *a* can be determined directly by means of a spring-balance. Exhaust the arm thoroughly, then grasp the hook of the spring-balance, the dial of which should be turned from the face of the experimenter, the reading being done by an assistant. After several minutes the muscles tire, and the practised experimenter can then gradually relax them fully. Untrained muscles, when thus tried, act involuntarily, and precise

\* This is only approximately true, but is accurate enough for our purpose. We shall develop this point further on.

† This is a highly important point. Try to lift 20 kilos. in a second of time through 0.7 metres. You will fail to lift it once, and yet not be exhausted. The problem of maximum velocity attainable with different weights, is wholly different from the one under consideration. I think Mr. Haughton has overlooked this influence on his own experiments.

results cannot be obtained. The mean of ten determinations gave, for my right arm,  $a = 1.50$  kgr. The mean of twenty determinations likewise gave  $a = 1.50$  kgr., with a probable error of 0.01 kgr. Calculating from (6) the values of  $W$  for the different values of  $w$ , and co-ordinating these two quantities, and it is plain that the function is hyperbolic. It was found that  $W$  did not vary inversely as  $(w+a)$ , or as any power of this quantity.\* The equation

$$(w+a)hn = \frac{c}{w^2} \quad (7).$$

was then assumed, where  $c$  and  $v$  are constants to be determined. From this we readily have

$$\log. (w+1.5) + \log. n = k - v \log. w,$$

which is of the form

$$y = k - vx,$$

where  $y$  and  $x$  can be calculated from the observations. Co-ordinating these values of  $y$  and  $x$ , and the curve is found to be linear, and we find  $v$ , as the change in  $y$  for each unit of change in  $x$ , to be 2.007. Hence Eq. (7) becomes

$$(w+a)hn = \frac{c}{w^{2.007}} \quad (8).$$

Calculating now the values of  $a$  and  $c$  by the method of least squares, we find  $c = 4261$  and  $a = 1.52$ . The difference between  $a$  (calc.) and  $a$  (obs.) is only 1.3 per cent. of  $a$  (obs.) Solving (8) for  $n$ , and substituting the proper values, and we have  $n$  (calc.), as given in Table II.  $dn$  is the difference in per cent. of  $n$  (obs.). Column  $e$  is the probable error of  $n$  (obs.), also in per cent. The comparison between  $n$  (calc.) and  $n$  (obs.) is shown graphically in Fig. 3, the observations being represented by the small circles.

Soon after arriving at Eq. (8), Prof. Haughton's book came to hand, containing his reduction resulting in Eq. (5). As already shown, this equation does not represent my later and more accurate observations. In order to test the matter still further, experimentally, the following experiments were made:—

1. I lifted my right arm from a vertical to a horizontal ( $h = 0.71$  cm.), the experiments being conducted exactly as in the case of those given in Table II. The arm was lifted 2,000 times without feeling any appreciable exhaustion. According to (5), when  $w = 0$ , complete exhaustion should occur when  $n = 1,000$ . According to (8) it should occur when  $n = \infty$ .

2. A weight,  $w = 0.5$  kgr., was lifted in the same manner, and the arm allowed to drop with the weight during the interval of rest, as in case of my earlier experiments. It was thus lifted 1,500 times with very little exhaustion. According to (5) complete exhaustion should occur when  $n = 400$ . According to (8)  $n$  should be 12,000. This would make the total time of exhaustion 3 hours and 20 minutes. The total mechanical work would be 16,800 kgr. metres. The daily labour of a working man is about 100,000 kgr. metres. From estimates based upon this fact, and from the slight fatigue felt in the second experiment, I am convinced that my arm, at its mean strength, could work for 8½ hours at the above rate, if the experiment were conducted as described above, care being taken to eliminate the fatigue caused by standing on the feet, &c. It would, however, be a highly dangerous experiment.

It will be remembered that each value of  $n$  (obs.) in Table II. is a mean of ten independent determinations. It occurred to me to co-ordinate the originally observed values of  $n$  with the daily determination of strength  $c$ . The result was most instructive. Each value of  $w$  gave a curve which is really parabolic, but which—since one of these curves ( $w = 5.0$ ) was taken as a unit in which to represent the others—appeared here as a straight line, or, very nearly so, with exception of those which had been before rejected in calculating the constants. The reason for the great value of  $n$  for  $w = 2.5$  (Table II.) is thus apparent.

This at once opened up a new field—the relation of strength to work. In the investigations here the strength is determined by a spring balance, so arranged that the arm is held horizontally and the strain exerted upwards. Calling  $s$  the reading of the dynamometer, and the strength is  $(w+a)$ .† Co-ordinating, for the different weights used in Table II., the strength with the work done before exhaustion, and we have for each value of  $w$  a curve which is apparently parabolic, intersect-

ing the axis of abscisse (strength) at a point just inside the point where  $s + a = w + a$ .\* As  $w$  diminishes, the curves increase in steepness with great rapidity. Eq. (8) shows the relation between the points on each of these curves, which correspond to my mean strength.

This opens up a way of estimating the statical work of a muscle, a problem which has been in view from the outset. We will take as the unit of statical work, the *kilogram-second*, or the work done by a muscle in sustaining for one second a strain of one kilo. exerted at right angles to its line of contraction. If now the same weights be used in exhausting the horizontally outstretched arm, we shall have by co-ordinating the work (in kgr.-sec.) with the strength, a system of curves as in the case of dynamical work. Accurate values of the constants for these curves have not yet been obtained, and we therefore will not discuss them further here. For each weight, co-ordinate the dynamical with the statical work, and it is readily seen that the relation between them can be made out, so that—given the total energy of a muscle in kgr.-sec. with any weight, and we can calculate the dynamical work in kgr.-metres which this same muscle could do with this same weight. I intend to determine as accurately as possible the values of the constants in the cases heretofore discussed in these papers. I shall also thus investigate the effect of variation of the angle of elevation of the arm on the dynamical and statical work, including the case of statical work where the angle of elevation is zero: also the dynamical work, where the strain on the muscles is *continuous*, and (1) where the strain on the muscles ( $a$  weight) is constant, and the velocity of motion uniformly varied; (2) where the velocity is constant, and the weight uniformly varied; and (3) where both weight and velocity are constant. Making in this latter case,  $v = a$ , and we have the case of statical work. The apparatus necessary for this investigation has been already devised. FRANK E. NIPHER

### SCIENTIFIC SERIALS

*Zeitschrift der Oesterreichischen Gesellschaft für Meteorologie*, Dec. 15.—To this number Dr. Prestel contributes an article on lines of cirrus as a means of foretelling storms. Storm signals he presumes to be inadequate for warning sailors of an approaching gale. He has compared during last year the indications of cirrus streaks with the weather shown by the charts to be prevalent on each day when his observations were made. From all the instances in which the streaks were well developed, he comes to the conclusion that the currents of the upper air do not follow the law of Buys Ballot; that is, that in the region of cirrus the air has neither a cyclonic nor anticyclonic movement, but streams from the point of highest pressure in the area of high pressure to the point of lowest pressure in the area of low pressure.—Herr Köpken, having remarked the tendency of cyclones to follow closely upon one another, gives a table for Northern Russia of the intervals which most commonly separate them. Of 107 cyclones, occupying 393 days in the territory, 33 per cent. came in less than twenty-four hours after their predecessors; 32 per cent. after an interval of one day; 19 per cent. after two or three days; 19 per cent. after four, five, or six days; and 18 per cent. after seven, eight, nine, or ten days.—The observations of MM. Faurat and Sartiaux, by which it appeared that more rain fell within than without the forest of Halatte, are objected to on account of the disturbing influence of wind, which blows less stongly at the one position, six metres above tree-tops, than at the other, fifteen metres above the plain.

*Reale Istituto Lombardo. Rendiconti*: vol. vii. fasc. ix., xi.—The first paper is On variations in the temperature of Milan, by Giovanni Celoria. Meteorological observations were commenced at the Observatory of Brera in 1763, and have been carried on without intermission, and show regular and irregular variations. The maximum temperature follows the culmination of the sun, and shows an oscillation in time of seventy minutes, being at 2h. 4m. in January and at 3h. 14m. in July. The minimum temperature in summer is eight minutes before the rising of the sun, and in winter forty-nine minutes before sunrise. This variation is less at Milan than elsewhere. The author follows Dove in dividing the year into seventy-three periods of five days each. There are two periods of medium temperature in the year, April 15 and 16, and October 18; 179 days are colder and 186 hotter

\* My left arm is about five-sixths the strength of the right. Each varies greatly from day to day. Several other persons, the length of whose bones approximated my own, have been experimented upon. The co-ordinated values of work and strength are continuous with my own.

\* The equation  $(w+a)hn = \frac{c}{(w+a)^{2.007}}$  will represent the observations, but it is a highly improbable relation

†  $(z+a)$  is really the highest tension attainable by the muscle in exerting a uniformly accelerated force, with a uniform velocity through the space moved over by the hook of the dynamometer.

than these. May shows no regular retrogression of temperature, as in northern countries, though it is more variable than other months, and there is no Martinmas summer in autumn; thus confirming the doctrine that the Alps divide Europe into two meteorological regions. There are also variations coincident with the periods of sun-spots. Thus, from 1763 to 1768, from 1812 to 1817, from 1829 to 1838, from 1855 to 1858, the annual temperature was lower than the average; while from 1769 to 1772, from 1778 to 1781, from 1790 to 1794, from 1796 to 1798, from 1824 to 1828, from 1861 to 1872, excluding the years 1864 and 1871, the temperature was constantly higher.—The next paper is by Prof. Gaetano Cantoni, On the direct assimilation of nitrogen from the atmosphere. Having compared the production of corn and clovers, the author concludes that the Leguminosæ can absorb nitrogen from the air, but that Gramineæ have not this power.—Prof. Tullio Brugnatelli and Dr. Pelloggio publish the results of their examination of the mineral water of Monte Alteo. It is sulphurous, and will keep for months in sealed bottles, but ultimately develops *Cryptococcus brumes*. Its temperature is 13° C.; it smells like a saturated solution of sulphuric acid, but is not unpalatable. A litre gives a solid residue of 3.96 grains, chiefly formed of chloride of sodium and sulphates of magnesia and lime.—Prof. Leopoldo Maggi contributes a note On the distinctions introduced in spontaneous generation, and defines clearly and adopts the terms agenia, necrogenia, and xenogenia, introduced by Milne-Edwards, and suggests that agenia may be divided into inorganic and organic agenia. A reading of this paper, Prof. Sangalli remarked that he found long Bacteria and Micrococcus in an ulceration in the throat, and the same organisms in a diseased stomach.—The next paper is by Prof. Achille de Giovanni: Clinical and anatomical observations concerning the pathology of the sympathetic system; in which his researches respecting the infiltration of the intercostal ganglia are continued. In a former paper he attributed the infiltration to the growth of numerous adventitious vessels, but in a section of a ganglion hardened in a solution of bichromate of potash the presence of a very fine connective tissue is easily seen to accompany the nerve-tubes and involve the ganglia, and in this he believes some deposits to take place.—The last paper in Part xi. is by Prof. Sayno, On a machine for drawing spirals, which he figures.

## SOCIETIES AND ACADEMIES

### LONDON

**Royal Society, Jan. 21.**—On the anatomy of the connective tissues, by G. Thin, M.D.

Transparent animal tissues, when sealed up fresh in aqueous humour or blood-serum, by running Brunswick black round the edge of the cover-glass, undergoes a series of slow changes, by which, mostly within a period of two to five days, anatomical elements otherwise invisible become distinct. The paper is chiefly a record of observations made by this method. The author describes the results of its employment in the case of sections of the cornea, in which the stellate-branched cells are seen, after about twenty-four hours, to consist of masses of protoplasm, sharply defined. He has also similarly examined tendon neurilemma, fibrillary tissue, nerve-bundles, and muscular fibre; and compared the results with those arrived at by other methods of treatment.

**Jan. 28.**—On the atmospheric lines of the solar spectrum, illustrated by a map drawn on the same scale as that adopted by Kirchhoff, by J. H. N. Hennessey, F.R.A.S. Communicated by Prof. Stokes, Sec. R.S.

The spectroscopic observations described in this paper were made with instruments belonging to the Royal Society, and in accordance with certain suggestions which had been made to the author by a committee appointed in consequence of a letter of his to Sir Edward Sabine, president, dated 13th February, 1866. In view of his residence at a considerable height above the sea-level, and of the exceedingly clear atmosphere prevailing at some periods of the year, it was suggested that the locality was peculiarly favourable for a determination of the lines of the solar spectrum due to atmospheric absorption; and that for this purpose the solar spectrum when the sun was high should be compared with the spectrum at sunset, and any additional lines which might appear in the latter case should be noted with reference to Kirchhoff's map.

Accordingly the author set to work with the spectroscope

first supplied to him, and in the autumns of 1868 and 1869 mapped the differences in question from the extreme red to D. These results appeared in the "Proceedings of the Royal Society" for June 16, 1870, and the map of the spectra, sun high and sun low, of the region in question forms Plate I. of the nineteenth volume.

The instrument first supplied to the author was found in practice to be of insufficient power to permit of ready identification of the lines seen in the spectrum of the sun when high with those represented in Kirchhoff's map; and a new spectroscope of greater power was supplied to him, which reached him at the end of the year 1871. Observations for a continuation of his map had in the mean time been taken with the old instrument in the autumns of 1870 and 1871, and the spectrum mapped from D to F, in continuation of the former map. But the new instrument proved so superior to the old, that the author determined to map the whole spectrum afresh from observations made with it, using the former maps merely as skeleton forms. The observations with the new instrument were carried on in the autumns of 1872 and 1873, and the map now presented is the result.

Observations were also made to ascertain whether any of the lines which came out when the sun is low, especially those which are also seen, but narrower and less conspicuous, when the sun is high, could be due, not to specific atmospheric absorption, but to the general weakening of the light, causing parts of the spectrum already weakened by solar absorption to appear dark when a general weakening of the light was superinduced, though they had appeared bright when the light was strong. For this purpose the spectrum of the sun when high, as seen in the usual way, was compared with the spectrum when the intensity was artificially reduced in various ways. The best comparison was obtained by taking advantage of a natural phenomenon. At Mussorie, late in the autumn, a haze, visible at sunset, extends over the low country, and grows day by day in height, till it causes the sun virtually to set in haze while still 3° or more above the horizon, whereas in the clear season it is visible till it attains a depression of 13°. The result of the comparison was, that none of the additional lines were discovered to have any other origin than selective atmospheric absorption.

**Royal Horticultural Society, Jan. 20.**—Scientific Committee.—Dr. J. D. Hocker, C.B., Pres. R.S., in the chair.—The Rev. M. J. Berkeley exhibited specimens of vine stems with large burr-like excrescences, which he suggested might be due to the attacks of a fungus like *Exobasidium*.—Mr. Worthington Smith exhibited a drawing of the microscopical appearance of the swellings on cucumber roots, confirming the accuracy of the observation long since made by the Rev. M. J. Berkeley, which connected these swellings with the presence of nematoid worms—probably an undescribed species of *Tylenchus*.—Prof. Thistleton Dyer called attention to a communication made to the Entomological Society by Prof. Forel, in which there was evidence to show that the Phylloxera had been introduced into vineyards belonging to Baron Rothschild in the commune of Pregny, in the canton of Geneva, from England. The Phylloxera was discovered in England in 1863 by Prof. Westwood.—Prof. Thistleton Dyer also called attention to the statement in the *Daily News* (Jan. 19), that the Imperial Chancellor had introduced at the sitting of the Federal Council at Berlin on Jan. 18, an ordinance "prohibiting the importation of potatoes and the refuse and packing materials of potatoes from the United States," the object being to prevent the Colorado beetle from being imported into Germany. It was stated that the English Government had refused to prohibit the entry of American potatoes, on the ground that "it does not appear that the eggs or larvae of the beetle have been or are deposited in the tuber of the potato." Mr. Andrew Murray described from his own observation the ravages effected by the beetle in Canada. Mr. McLachlan remarked that the beetle seems to have first spread from Mexico.—Prof. Thistleton Dyer stated with reference to the fruiting of *Hibiscus ros-sinensis*—which had been said on the authority of Dr. Cleghorn not to take place even in India—that ripe capsules had been obtained after artificial fertilisation at Mauldsie Castle, Carlisle, N.B., in 1871 and 1872, and plants raised from the seeds.—Dr. Masters exhibited specimens from Mr. Corderoy, of Didcot, of mistletoe parasitic on itself.

General Meeting.—Mr. W. A. Lindsay in the chair.—The Rev. M. J. Berkeley commented on the objects exhibited.—Mr. Bull showed a fine collection of Cyadaceous plants.—Mr.

Parker sent specimens of *Aponogon distachyon*, flowered in the open air at Tooting, in a pond supplied by a spring, the temperature of which never fell below freezing-point.

**Anthropological Institute**, Jan. 26.—Prof. Busk, F.R.S., president, in the chair.—Anniversary meeting.—In the Report for 1874, the Council stated that the Institute had been enabled through the liberality of its members to pay off the debt which had so long burdened it, and that one of the immediate advantages arising from its improved position would be the more regular issue of its *Journal*, which in future would contain varied anthropological news and notices in addition to its usual proceedings.—In his address, on his retiring from the presidency, Prof. Busk gave a summary of the chief works and memoirs on the many branches of anthropology that had appeared during the past year, especially referring to the labours of Prof. Owen, M. Mortillet, Dr. P. Broca, Dr. A. B. Meyer, Madame Royer, &c.; and in conclusion, he drew attention to the comprehensive range of subjects contained in the proceedings of the Institute, and to the professed aim of the Council to exclude no subject that could possibly be embraced under the general term of Anthropology. The officers and Council to serve for 1875 were elected as follows:—President, Col. A. Lane Fox, F.S.A. Vice-Presidents: Prof. George Busk, F.R.S., John Evans, F.R.S., A. W. Franks, F.R.S., Francis Galton, F.R.S., George Harris, F.S.A., Sir John Lubbeck, Bart., F.R.S. Directors: E. W. Brabrook, F.S.A., F. W. Rudler, F.G.S. Treasurer, Rev. Dunbar I. Heath, M.A. Council: J. Beddoe, M.D., F.R.S., W. Blackmore, H. G. Bohn, F.R.G.S., Hyde Clarke, J. Bernard Davis, M.D., F.R.S., W. Boyd Dawkins, F.R.S., Robert Dunn, F.R.C.S., David Forbes, F.R.S., Sir Duncan Gibb, Bart., M.D., Chas. Harrison, F.R.S.L., J. Park Harrison, M.A., Prof. T. McK. Hughes, F.G.S., T. J. Hutchinson, F.R.G.S., Prof. Huxley, F.R.S., F. G. H. Price, F.R.G.S., J. E. Price, F.S.A., C. R. Des Ruffières, F.R.S.L., Lord Arthur Russell, M.P., Rt. Hon. D. H. Stone, E. Burnet Tylor, F.R.S.

**Medical Microscopical Society**, Jan. 15.—Mr. Jabez Hogg, the retiring president, in the chair.—From the report of the committee it appeared that the society was in a flourishing condition, the number of members being 135. The number of papers read during the past year was sixteen, besides several minor communications, all of which were followed by brisk discussion. Above 100 specimens were exhibited during the year, and eighteen presented to the society. A present was also announced of a microscope for use in the exchange of specimens, a system which is found to work well and offers great facilities for obtaining a large collection of good preparations. The treasurer's report showed a balance of 15*l.* 10*s.* The following officers were elected:—President, Dr. J. F. Payne. Vice-Presidents: Mr. Jabez Hogg, Mr. W. B. Kesteven, Mr. H. Power, Dr. U. Pritchard. Treasurer, Mr. T. C. White. Hon. Secretaries: Mr. C. H. Golding Bird, Mr. J. W. Groves. Committee:—St. Bartholomew's, Mr. J. A. Omerod; Charing Cross, Dr. M. Bruce; St. George's, Mr. E. C. Baber; Guy's, Mr. F. Durham; King's, Mr. H. S. Atkinson; London, Mr. J. Needham; St. Mary's, Mr. George Giles; Middlesex, Dr. S. Coupland; St. Thomas', Dr. W. S. Greenfield; University College, Mr. E. A. Schäfer; Westminster, Dr. W. H. Alchin; General Profession, Dr. Foulerton. The retiring president then read an address.

## DUBLIN

**Royal Irish Academy**, Dec. 14.—William Stokes, F.R.S., president, in the chair.—Dr. S. Ferguson, vice-president, read a paper on further Ogham texts from Monastagart, County Cork.—Mr. W. Archer read a paper descriptive of the apothecia and spores found by him in two species of *Scytonema* and two of *Sirospira*, and one of *Stigonema*, all of them specifically different from any of the few similar cases hitherto recorded.—Mr. R. C. Tichborne read a paper entitled "Laboratory Notes." On the solution of alloys and metals by acids; on fluorescence as a means of detecting adulteration; on the printing inks of the 16th and 17th centuries.—Mr. G. R. Leeper read a paper on retro-peritoneal cavities in man.

## MANCHESTER

**Literary and Philosophical Society**, Dec. 29, 1874.—Mr. E. W. Binney, F.R.S., vice-president, in the chair.—On a case of reversed chemical action, by Mr. James Bottomley, B.Sc. Having observed the solubility of iodine in a solution of borax, an experiment was made to see what the result of this solution would be, expecting to obtain a combination of soda with excess

of acid. 27*8*475 grms. of borax were dissolved in about 250 grms. of water. The iodine was added at hazard, the quantity used being nearly seven grms. When assisted by heat, almost the whole of this quantity dissolved in the solution. The solution, which amounted to about 200 cc., had only a faint yellowish tint. Being set aside for some days, it deposited crystals which proved to be ordinary borax, or 0*5*932 grms. of the crystals lost by heating 0*2*773 grms. of water of crystallisation, corresponding to 46*7*5 per cent., the theoretical quantity being 47*1*3. After removing the crystals the solution was still further evaporated in a retort. As the evaporation proceeded, instead of the faint yellow tinge disappearing as was anticipated, the colour of the solution began to darken, finally becoming opaque owing to the quantity of free iodine in solution; vapours of iodine were also given off along with the steam. Thus the iodine which had previously dissolved and chemically united with the soda when the solution was dilute, was displaced and eliminated in the free condition when the mixture was past a certain degree of dilution.

The explanation of this reversal of chemical action is as follows. When sodic borate is diluted with water, its constituents are so far dissociated that the iodine acts towards the soda in the same way as it would towards caustic soda, sodium iodide and sodium iodate being the result. When, however, the solution is concentrated, the boric acid, notwithstanding its feeble acid power, is able to displace continuously and simultaneously small quantities of iodide and hydroiodic acid from combination with sodium, but these two acids cannot coexist in the free state; by mutual reaction they give iodine and water.

Jan. 12.—Mr. R. Angus Smith, F.R.S., vice-president, in the chair.—On the action of rain to calm the sea, by Prof. Osborne Reynolds, M.A. There appears to be a very general belief amongst sailors that rain tends to calm the sea, or, as I have often heard it expressed, that rain soon knocks down the sea. Without attaching very much weight to this general impression, my object in this paper is to point out an effect of rain on falling into water which I believe has not been hitherto noticed, and which would certainly tend to destroy any wave motion there might be in the water. When a drop of rain falls on to water the splash or rebound is visible enough, as are also the waves which diverge from the point of contact; but the effect caused

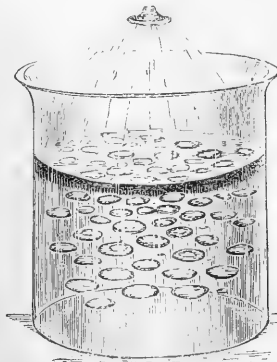

by the drop under the surface is not apparent, because, the water being all of the same colour, there is nothing to show the interchange of place which may be going on. There is, however, a very considerable effect produced. If instead of a drop of rain we let fall a drop of coloured water, or, better still, if we colour the topmost layer of the water, this effect becomes apparent. We then see that each drop sends down one or more masses of coloured water in the form of vortex rings. These rings descend with a gradually diminishing velocity and with increasing size to a distance of several inches, generally as much as eighteen, below the surface. Each drop sends in general more than one ring, but the first ring is much more definite and descends much quicker than those which follow it. If the surface of the water be not coloured this first ring is hardly apparent, for it

appears to contain very little of the water of the drop which causes it. The actual size of these rings depends on the size and speed of the drops. They steadily increase as they descend, and before they stop they have generally attained a diameter of from one to two inches, or even more. The cut on p. 279 shows the effect which may be produced in a glass vessel. It is not that the drop merely forces itself down under the surface, but in descending carries down with it a mass of water which when the ring is 1 inch in diameter would be an oblate spheroid having a larger axis of 2 inches and a lesser of about  $\frac{1}{3}$  inches. For it is well known that the vortex ring is merely the core of the mass of fluid which accompanies it, the shape of which is much the same as that which would be formed by winding string through and through a curtain ring until it was full. It is probable that the momentum of these rings corresponds very nearly with that of the drops before impact, so that when rain is falling on to water there is as much motion immediately beneath the surface as above it, only the drops, so to speak, are much larger and their motion is slower. Besides the splash, therefore, and surface effect which the drops produce, they cause the water at the surface rapidly to change places with that at some distance below. Such a transposition of water from one place to another must tend to destroy wave motion. This may be seen as follows. Imagine a layer of water adjacent to the surface and a few inches thick to be flowing in any direction over the lower water, which is to be supposed at rest. The effect of a drop would be to knock some of the moving water into that which is at rest, and a corresponding quantity of water would have to rise up into the moving layer, so that the upper layer would lose its motion by communicating it to the water below. Now, when the surface of water is disturbed by waves, besides the vertical motion the particles move backwards and forwards in a horizontal direction, and this motion diminishes as we proceed downwards from the surface. Therefore in this case the effect of rain-drops will be the same as in the case considered above, namely, to convey the motion which belongs to the water at the surface down into the lower water where it has no effect so far as the waves are concerned, and hence the rain would diminish the motion at the surface, which is essential to the continuance of the waves, and thus destroy the waves.—On the stone mining tools from Alderley Edge, by Prof. W. Boyd Dawkins, F.R.S.—Archaic iron mining tools from lead mines near Castleton, by Mr. Rooke Pennington.

## PARIS

**Academy of Sciences, Jan. 25.**—M. M. Frémy in the chair.—The following papers were read:—On the decrease of the upper Doubs and the means to prevent it, by M. H. Rezel.—On the effect produced by the application of armatures on magnets, by M. J. Jamin.—On the mineral substances contained in the juice of beet and the potash extracted from it, by M. E. Peligot.—On the fertilisation of the genus *Viola*, with special reference to *Viola tricolor hortensis*, by M. A. Trécul.—On the phosphorescence of Marine Invertebrata, by M. de Quatrefages.—M. Daubrée then read a letter received from H. M. Don Pedro, Emperor of Brazil, giving a description of an earthquake which took place on Oct. 30 last in the province of St. Paul.—The same gentleman then communicated a memoir by M. J. D. Dana, on the Pseudomorphs of Serpentine and other minerals from the mine Tilly-Foster, Putnam County, State of New York.—Researches on albuminoid matter, by M. P. Schützenberger.—On the action of electrolytic oxygen on methylic alcohol, by M. A. Renard; experiments made in continuation of those described on Jan. 11 (see NATURE, vol. xi. p. 240). The results were similar, producing acetic acid, acetate of methyl, and methyl-sulphuric acid. The formation of acetic acid from methylic alcohol is explained by the formulæ—

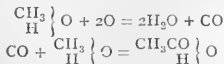

—On the flame of sulphur, and the different lights that can be utilised in photography, by MM. A. Riche and C. Bardy. The authors examined eight different flames, viz., the oxy-hydrogen light, Drummond's lime-light, zinc burning in oxygen, the magnesium flame, a current of nitric oxide gas burning in a globe containing bisulphide of carbon, a jet of nitric oxide gas on a test containing bisulphide of carbon, a jet of oxygen on the same, and a jet of oxygen on a test containing sulphur. The eight lights showed their photographic power in the order mentioned, the last being eight times as strong as the first.—After some short mathematical notes, M. D. Lontin read a paper on his

improvements of dynamo-electric machines.—A note by M. Lecareux, on the treatment of cholera.—A memoir by M. Anninos, on the direction of acrostats.—MM. Hemmerich, Bourquelot, Chaperon, Heyduck, and Robinson then made some communications on Phylloxera. The Minister for Agriculture and Commerce has placed more funds at the disposal of the Academy for the investigation of this subject.—A letter was then read, dated Noumea, Nov. 4, 1874, from MM. André and Angot, announcing their successful installation for the observation of the Transit of Venus.—The Minister for Foreign Affairs transmitted to the Academy documents received from the French Consul at Manilla, with reference to the same subject, and announcing the forwarding of ten photographic proofs taken during the transit.—A letter on the same subject from M. Héraud, dated Saigon, Dec. 18, giving a complete description of the observations and their results.—A letter from Mr. J. Norman Lockyer, describing the preparations for the expedition sent by the Royal Society of London to observe the total eclipse of the sun. The observations will be mainly confined to the spectra of the chromosphere and the coronal atmosphere, with the principal view to determine the chemical constitution of the latter.—On elimination; calculation of Sturm's functions by determinants, by M. Lemonnier.—A note on the partition of numbers, by Mr. Glaisher.—A note on the theory of surfaces, by M. Halphen.—On a formula of transformation of elliptic functions, by M. J. Brioschi.—A note by M. T. Schloesing, on atmospheric ammonia.—On the presence of copper in the organism, by MM. Bergeron and L'Hôte.—On the general phenomena of the embryogeny of Nematida, by M. J. Barrois. M. de Quatrefages then made a few remarks on this paper.—On the organs of touch in man, by M. Jobert.—On the invasion of grasshoppers in Algeria (April—August, 1874), by M. Brocard.—On the electrochemical resistance of aluminium when employed as a positive electrode of a voltmeter, by M. Ducretet.—M. Chapelas then gave an account of barometrical observations he made in Paris during the gale on Jan. 21.—M. Mangot read a note on the causes of the rupture of axles, and generally of pieces of iron, that are subjected to repeated vibrations.

## BOOKS AND PAMPHLETS RECEIVED

**BRITISH.**—The Native Plants of the Pacific States of North America: Hubert Howe Bancroft (Longmans).—Aescyrian Discoveries: George Smith (Sampson Low and Marston).—Valleys, and their Relation to Fissures, Fractures, and Faults: C. H. Kinahan, M.R.I.A., F.R.G.S.L., &c. (Trübner).—Newcastle-upon-Tyne Chemical Society: On the Manufacture of Caustic Soda.—Bird Life, by Dr. A. E. Brehm. Translated by H. M. Labouchere, F.Z.S., and W. Jesse, C.M.Z.S. Parts 5 to 10 (John Van Voorst).—Logarithmic and Trigonometrical Tables for Approximate Calculation: J. T. Bottomley, M.A., F.R.S.E. (Wm. Collins).—Fragmentary Papers by the late Sir H. Holland: Rev. J. Holland (Longmans).—Outline of the Evolution-Philosophy of Dr. M. E. Gaskell. Translated by the Rev. O. B. Frothingham, of New York (Trübner).—The History of India from the Earliest Ages. Vol. iii.: J. Talboys Wheeler (Trübner).—The Countess of Chinchon and the Chinchona Genus: Clements R. Markham, C.B., F.R.S. (Trübner).

## CONTENTS

	PAGE
BOTANICAL PROBLEMS	261
SOUTH AMERICAN TRAVEL. II. ( <i>With Illustrations</i> )	262
WATSON'S "DESCRIPTIVE GEOMETRY"	265
PHILLIPS' "ELEMENTS OF METALLURGY"	266
OUR BOOK SHELF:—	
Schmidt's "Doctrine of Descent and Darwinism"	267
Griffith and Hentrey's "Micrographic Dictionary"	267
"Temperature Chart of the United States"	267
LETTERS TO THE EDITOR:—	
Sub-Welding Exploration.—J. F. BLAKE	267
The Rhinoceros in New Guinea.—Dr. A. B. MEYER; ALBERT O. WALKER	268
Geology and the Arctic Expedition.—SAMUEL ALLPORT	268
Upper Currents over Areas of Frost.—W. CLEMENT LEY	269
Decomposition of Iron Pyrites.—W. MATTHEU WILLIAMS, F.C.S.; GEO. LINGWOOD; A. P. WIRE	269
OUR ASTRONOMICAL COLUMN:—	
Variable Stars	269
The Zedical Light	270
Encke's Comet	270
Halley's Comet	270
ANNUAL REPORT OF THE WARDEN OF THE STANDARDS	270
SCHRIEBER'S EUROPEAN HERPETOLOGY	271
BOTANY IN QUEENSLAND. BY JOHN R. JACKSON	271
THE TOCK-TAY, OR LARGE HOUSE LIZARD OF EASTERN BENGAL	272
NOTES	272
DETERMINATION OF THE VELOCITY OF LIGHT AND OF THE SUN'S PARALLAX. BY M. A. CORNU	274
ON THE MUSCULAR MECHANICAL WORK DONE BEFORE EXHAUSTION, II. BY FRANK E. NIPHER ( <i>With Illustrations</i> )	276
SCIENTIFIC SERIALS	277
SOCIETIES AND ACADEMIES	278
BOOKS AND PAMPHLETS RECEIVED	280



THURSDAY, FEBRUARY 11, 1875

## HANCOCK'S "BIRDS OF NORTHUMBERLAND AND DURHAM"

*A Catalogue of the Birds of Northumberland and Durham.* By John Hancock. (London: Williams and Norgate. Newcastle-on-Tyne: F. and W. Dodsworth, 1874.)

A STATE of expectancy in which British ornithologists have for some years been living has at length been ended by the appearance of Mr. John Hancock's "Catalogue of the Birds of Northumberland and Durham," which we lose no time in recommending to the notice of such of our readers as are interested in this branch of natural history. It will of course most recommend itself to dwellers in those two counties, but it contains besides much that concerns the lovers of birds everywhere in the British Islands, and its author has our warmest congratulations on the completion of his work in a form so inviting; while the Natural History Society of Northumberland, Durham, and Newcastle-upon-Tyne, and the venerable Tyneside Naturalists' Field Club—at the joint expense of which it is produced—deserve our heartiest thanks for its publication.

Mr. John Hancock has long been known to some who, though comparatively few in number, are perhaps best able to form an opinion, as one of the closest and most careful observers of birds and bird-life in this country. The circle of his admirers would have been indefinitely wider but for the reticence which his natural modesty has for years made him keep. While others without a tittle of his knowledge have ostentatiously come forward as teachers so as to acquire a character as "celebrated ornithologists" out of all proportion to their ability, he has been content to look on, seldom obtruding on the public any of the results of his experience, and then perhaps only at the earnest solicitation of some particular friend. Yet this ornithological oracle of the North of England has never been hard to consult, and the number of those who, through information privately derived from him, have in a manner reaped the fruit of his continual observation—not always, we fear, with due acknowledgment on their part—is not inconsiderable. It is, therefore, with great pleasure that we find he has at last summoned courage to speak for himself. As a consequence of his diffidence, a good deal of what he has to tell us has oozed out through other channels, but there is more than sufficient novelty in the 200 and odd pages of this "Catalogue" amply to repay their study, and even when facts ascertained by him have been announced before, it is most satisfactory to have the record of them here stamped by his personal authority. It will be news, we take it, to most people to learn that Mr. Hancock was the first who recognised Bewick's Swan as a distinct species;\* and we cannot but wonder that forty-five years and more have been allowed to elapse before this fact was made publicly known. Yet Mr. Hancock shows not the least trace of annoyance at the way in which his claims have been overlooked—his conduct in this respect being

\* This he did in January 1829. Pallas had described it as a variety in 1811, and it was not till November 1829 that Yarrell announced himself satisfied that it was anything else.

in exemplary contrast to the selfish and utterly unphilosophical squabbling as to "priority" which so often disgraces the votaries of all sciences. To him it is enough that a discovery was made; if important, so much the better; but, so long as knowledge has been extended, it matters nothing by whose means the end was attained. If we have not here a practical illustration of true scientific spirit, it will be difficult to meet with it anywhere.

We are therefore somewhat at a loss how to treat the work of a man so indifferent to what is called by the vulgar "fame." To pick out and here recount the various discoveries which, whether before announced or not, are due to Mr. Hancock, would be to set at nought the example given by his 'preaching and practice. The discrimination of the Iceland and Greenland Falcons, a question that has agitated ornithologists both here and on the Continent in no common degree, was first settled by Mr. Hancock in 1854. Yet to him the chief value of the discovery seems to be that it enables him to lay down the general law:—

"Not only do all the noble or true falcons acquire their adult plumage in the first moult, but many of the ignoble species do so likewise, as the Honey Buzzard, the Goshawk, the Sparrow-hawk, and the Harriers. This fact cannot be too strongly pressed on the attention of ornithologists, for it leads to a correct understanding of the variations of the plumage of the *Falconidae*." (P. 10.)

This is no mere *dictum*, but the result of long-continued observation; and well indeed would it be were writers, who have very recently attempted to deal with this subject, to learn as Mr. Hancock has done, in Dame Nature's simple school, instead of perpetuating error and confusion by grandly setting forth their unsound and arbitrary views on the "first year's," "second year's," and "third year's" plumage of birds of prey.

The work before us is most strictly what its title professes, a "Catalogue," and does not pretend to give a complete history of the birds found in the two counties; in other words, to be a "Fauna" of the class. But it is a catalogue conceived in no narrow spirit, for the author, as the extract just given shows, is on occasion not averse to add remarks having a very general bearing. To few of these will our space allow us to call attention, but we must especially notice the valuable "Introduction," wherein, after briefly touching upon former lists of the birds of the district, and comparing, not without some justifiable pride, its ornithological wealth (265 species) with that of Norfolk (280 or 290 species)—the richest county in this respect of the whole United Kingdom—Mr. Hancock gives an admirable account of the physical features of Northumberland and Durham. Concise as it is, we cannot here reproduce it; we must leave it to our readers, and only extract a few passages:—

"Our extensive seaboard lies in the direct line of the annual migrations to and from the northern latitudes, and is well fitted to the requirements of many species of sea-fowl. The coast in many parts is bold and rocky, but is agreeably varied with beautiful sandy beaches of vast extent, backed with wild hummocky 'links,' and not unfrequently with belts of bog and pools of sedgy water. There is also no want of muddy flats or estuaries, though these features are fast disappearing under the necessities of commerce.

"The northern and western portions of the counties are

wild and hilly. The Cheviot range attains an elevation of 2,658 feet, and this, along with that of Simonside, gives quite a sub-alpine character to this portion of the country. In these uplands, the Eagle and Peregrine Falcon formerly had their abode. . . . The western part of Durham is also wild, moory, and mountainous, but of less elevation. These wild regions are characterised by vast tracts of grass land, in some places fine, in others coarse, boggy, and hummocky; and by extensive moors of heath, gorse, and bracken, with swamps, mosses, tarns, and lochs. . . . Numerous lively streams in pebbly beds, and whimpering rills, diversified with little lippering cascades, abound; some almost concealed under the scrubby foliage of their banks, others fully revealed and sparkling over their stony channels. . . .

"The cultivated regions are in some places well wooded, and the fields are mostly divided by thorn hedgerows, giving at once beauty to the landscape and shelter to the more delicate tribes of the *Passeres*. But such, particularly the warblers, find their haunts in our numerous wooded dells, or 'denes,' which abound in both counties, and by the shrubby banks of our burns or streamlets. Here the hawthorn, the blackthorn, the wild rose, and bramble, and undergrowths of all kinds, afford to these delicate songsters the shelter and seclusion they require. These 'denes,' of which Castle Eden Dene is a fine example, are frequently well timbered, deep, and have a stream running through them. The principal rivers, the Tyne, the Coquet, and the Wear, not to mention the bordering streams, the Tweed and the Tees, run through deep wide valleys, with, in many parts, well-wooded banks, affording likewise favourite homes for many feathered tribes. Besides such localities, there is no want of extensive woods dispersed throughout the counties, and well-wooded park grounds." (*Introduction*, pp. vii. viii.)

Some two or three localities, on account of their ornithological features, obtain special mention by Mr. Hancock. First of these is the well-known cluster of the Farne Islands, where in a limited area no less than fifteen species of sea-fowls breed. We would willingly recall the recollections of our first visit, nearly a quarter of a century since, to that sea-girt paradise, by transcribing Mr. Hancock's description of its charms, but the exigencies of space are not to be overruled, and we can only pay a tribute to the memory of the late Archdeacon Thorpe, who for so many years, ere Bird-Preservation Acts of Parliament were dreamt of, from proud Bamborough's tower threw the ægis of protection over his feathered tenants on the distant Farnes. No such thoughtful guardian had Jarro Slake or Dobham Shelf. The encroachments of the engineer have almost destroyed the former as a *statio gratissima mergis*, and probably not a single Teesmouth gunner has even a memory of the latter, though two hundred years since it entertained "an infinite number of sea-fowle which laye they Egges heere and there scatteringlie in such sorte, that in Tyne of breedinge one can hardly sett his Foote so warylye that he spoyle not many of their nests." Past also are the glories of another spot, though they continued much later. Hear Mr. Hancock:—

"But no locality in the North of England had such interest for the naturalist as Prestwick Car. The botanist, the entomologist, the conchologist, and the ornithologist, were all equally interested in this one of nature's most famous nurseries. Here the naturalists of the district had resorted for several generations to collect the objects of their respective studies. . . . It is an area depressed, as if by subsidence, of about 1,100 acres, and is of a rounded or subquadrangular form, about two miles in diameter;

and the surrounding land is little elevated. The greater or central portion is (or rather was, for it is now all changed) composed of peat, more or less covered with a growth of ling and heather, and of boggy, hummocky, coarse grass land; this central portion was surrounded by a belt of good pasture land varied with gorse or 'whin.' Towards the north and west boundaries there was a chain of pools, the largest and most important of which was called the Black Pool; towards the south extended another chain of pools, among which was the Moor-sport Pool. The Black Pool could not be less than a mile in length, and was of considerable width. There were three islands in it, two towards the east, and one towards the west end. The drainage was through this sheet of water, from which there was a cut, or open ditch, to the River Pont; but the fall was so slight that the drainage was very incomplete, and the water flowed backwards and forwards in accordance with the state of the river. These pools were on a peaty bottom, in which the remains of numerous trees, chiefly Scotch fir and birch, stood erect, and firmly rooted. They were not visible above the surface of the water, though in droughty seasons numbers of them were frequently exposed near the margins of the pools. The trees were of no great size, and in most instances the wood was in such a good state of preservation, and contained so much resin, that it was used by the neighbouring villagers for firewood." (Pp. xii. xiii.)

This priceless nursery of plants and animals and delicious recreation-ground of naturalists was drained in 1857, and with its disappearance vanished many of its frequenters. "The birds that congregated there have been dispersed, and several that had on account of their breeding in that place ranked as residents, have now become mere visitants." Its destruction, therefore, has not failed materially to affect the ornithology of the district. Hence Mr. Hancock is led to remark on the wholesale extermination of some species, and in one point at least, that of the birds of prey, what he says merits every attention:—

"This policy of the game-preserved is of questionable utility in promoting the increase of game; nor does it appear that much has been achieved in this respect, for, after some inquiry, I cannot ascertain that either partridges or grouse are more numerous than they were some years ago when birds of prey were yet to be seen on the wing." They are not, he continues, "an unmitigated evil; they are a necessary part of the great scheme of nature, and may be essential to the perfectly healthy development of the birds they feed upon. It is undoubtedly advantageous that the feebly organised and sickly individuals should be weeded out, and this is done by birds of prey. We have of late years heard much about stamping out epidemics among mankind. It is a function of the Peregrine and its congeners to assist in stamping out epidemics among game-birds." (Pp. xviii. xix.)

Mr. Hancock has some hard and well-deserved strictures on the Wild Birds Preservation Act of 1872, which he rightly says shows the ignorance of those who drew up its schedule; but he does not seem fully to comprehend some of the practical difficulties attending any such measure. He complains that some species "stand in it under two, three, or even four different names," overlooking the fact that in different parts of the country certain species are known only by one particular and often very local name, so that if that name was omitted it would in such cases be impossible to obtain a conviction under the provisions of the Act. He also laments that some species, "the greatest favourites of the public,"

are excluded from its protection; but we may ask, is there any good ground for supposing that they require it?

There are a few other points in which we should be disposed, had we room, to discuss some of Mr. Hancock's opinions—but at all times with the greatest respect, for such is justly due to his authority. His assertion, for instance, as to the amount of variability in Cuckoos' eggs (p. 25) will hardly change the mind of those who have seen long series of specimens from Germany or other countries, or recollect the evidence of foreign ornithologists adduced some years ago in these pages (*NATURE*, vol. i. p. 266). Nor is it by any means certain that *all* birds "do not discriminate nicely the colours or other characters of their eggs." None of the examples he quotes to that effect are of kinds which act as foster-parents to the Cuckoo, and their case therefore can hardly be said to apply to "the theory of Dr. Baldamus." Again, too, we must remark that Mr. Hancock must have been exceptionally unfortunate in performing the experiments of Herr Meves to explain the "bleating" or humming of the Snipe. The late Mr. Wolley put on record his acquiescence in their satisfactory nature (*Proc. Zool. Soc.* 1858, p. 201), and a more competent witness could not be easily found, especially when we consider that his evidence was given after he was acquainted with the extraordinary and entirely different noise made by the smaller species of Snipe which has not stiff *rectrices*. We must therefore demur to Mr. Hancock's statement that "the neighing or bleating of the Snipe results from the action of the wings, and that any sound produced by the tail-feathers is inaudible."

It remains for us to notice the plates, fourteen in number, by which this work is embellished. All of them are characteristic, and most of them excellent; a fact especially to be noticed, since they are chiefly designed from birds stuffed and mounted by Mr. Hancock. Yet most of us who are old enough to remember his beautiful contributions to the Great Exhibition of 1851, to say nothing of specimens of his skill which we may have since seen elsewhere, have therein no cause for surprise. In the art of taxidermy—for art it is with him in a high sense—Mr. Hancock has no equal now, and possibly never had but one, the late Mr. Waterton; and the difference between specimens mounted as these are and the handiwork of ordinary bird-stuffers is apparent to anyone who has an eye for a bird. Whether Mr. Hancock's genius in this respect is innate, or whether it has been developed in him from a study of his fellow-townsmen Bewick's labours, matters not much; both artists may be rated equally high as delineators of birds, while the younger one, as the pages of this publication prove, stands as a naturalist immeasurably above the elder.

#### OUR BOOK SHELF

*Notes of Demonstrations on Physiological Chemistry.* By S. W. Moore, F.C.S., &c. (London: Smith, Elder, and Co., 1874.)

THE Preface to the "Notes of Demonstrations on Physiological Chemistry" states "the want felt by the average medical student, viz., hints as to which are the most important points in practical work which he can be expected to acquire," and "the impossibility for a class of men with only three hours a week at its disposal for

practical work to go through lengthy and uninteresting processes," induced the author to compile the "Notes," "so arranging them as to show the student methods that more nearly concern his immediate and future requirements." In other words, the book is not intended to treat thoroughly of any part of physiological chemistry, but only to remind the student of the principal points on which he is likely to be questioned, and to refer him for further information to the College Demonstration. To place a book of this kind in the hands of the medical student cannot be productive of good, as it enables him to acquire a pretence of knowledge that is, in his case especially, worse than the want of it. No one will deny it to be the duty of the teacher to confine the attention of students to those matters he regards as essential, and to pass over lightly those of less importance. But what will be the result if every teacher writes a book pointing out his mode of treating the subject? The effect will be to educate one-sided men, and to stifle all craving for further information. The only way to avoid this catastrophe is to recommend the use of a really good book, so that the student may acquaint himself with any part of the subject, or confine his attention solely to those points treated by the lecturer. The present work may be very useful to the author's pupils, but we cannot commend it as a satisfactory introduction to the subject of physiological chemistry.

*The Microscope and its Revelations.* By W. B. Carpenter, M.D., F.R.S. Fifth Edition. (London: J. and A. Churchill, 1874)

THE recent excellent investigations of Mr. Wenham, Col. Woodward, and others, on the optical principles of microscope construction and manipulation, together with the results obtained by the employment of immersion objectives, have added so much to our knowledge of the principles of minute investigation and the interpretation of the results obtained, that any standard work on "The Microscope" must necessarily require fresh editing. In the fifth edition, just published, of his well-known work on the subject, Dr. Carpenter shows how well he has kept pace with modern investigations. In it we find the most recent views on the nature of the markings on Diatoms fully entered into, the opinions of Col. Woodward, Mr. Stoddard, and Mr. Rylands, being clearly stated and criticised. The much discussed new principles and methods proposed by Dr. Royston-Piggott are in no wise omitted, the general tenour of the comments on their value being rather in their favour than otherwise. This last-mentioned subject the author has placed in the hands of Mr. H. J. Slack, the secretary to the Microscopical Society. In looking at the book as a whole, the question which we cannot help asking is, what is the limit to the points which should be touched upon in it? Why should certain tissues be described, and not others? Why should the organisation of some minute animals be entered into, while others are not referred to? We cannot answer this question ourselves, and think it will become more difficult to do so as every fresh fact in histology and minute zoology is added to the considerable mass already at our disposal.

*Ueber Algebraische Raumcurven.* Von Eduard Weyr.—*Ueber die Steiner'schen Polygone auf einer curve dritter Ordnung C und damit zusammenhängende Sätze aus der Geometrie der Lage.* Von Prof. Karl Küpper.—*Die Lemniscate in Rationaler Behandlung.* Von Dr. Emil Weyr. (Prag, 1873.)

THE first memoir (27 pp.) treats of curves in space, and then discusses special space-curves, viz., those of the fifth order, concluding with the consideration of curves of the sixth order and second and third class. Reference is made to Prof. Cayley's papers on the subject in the *Comptes Rendus*, tome liv. (1862).

The earlier part of the second memoir (28 pp.) treats of points, lines, and polygons, and swarms with results, upon the novelty or antiquity of which we cannot pronounce a judgment. We have then some proofs given of properties of the Tricuspid, which is the envelope of the feet perpendicular lines of an inscribed triangle. Steiner's enunciations ("Crelle," vol. 53) have been demonstrated by Prof. Townsend ("Reprint from *Educational Times*," vol. iv. pp. 13-17), Prof. Cremona ("Crelle," vol. 64), and by other mathematicians.\* An appendix of eleven pages, entitled "Ueber Raumcurven vierter Ordnung erster Art, und eine spezielle ebene curve vierter Ordnung  $C_4$ " closes the memoir.

The last memoir on our list (39 pp.) is a very interesting one, in which a great number of properties of the curve are established by means of its ordinary rectangular equation  $(x^2 + y^2)^2 - 2a^2(x^2 - y^2) = 0$ . We should like to see this memoir in an English dress. On the authority of a German friend, we may say that it is written in elegant German. All three memoirs are extracted from the "Abhandlungen der k. böhm. Gesellsch. der Wissenschaften" (vi. folge, 6 Band). Whether the practice obtains on the Continent to any extent of thus reprinting separate memoirs we cannot say, but we learn from a distinguished physicist that such is the case with the Vienna "Transactions," of which any paper may be had separately through a bookseller at a price published in the table of contents. This is a laudable practice, and in these columns the desirableness of its introduction into this country has been more than once dwelt upon. Happily, we learn from the President's address (NATURE, vol. xi. p. 197) that the Royal Society have the matter under consideration. As the reasons *pro* and *con* have so recently been given, it would be out of place here to dwell longer on the matter. We hope, however, that it will be possible on some terms or other to get separate memoirs in the case of those societies whose publications embrace two or more specialities. A practice obtains in some societies of allowing readers of papers to have extra copies of their own papers, at reasonable prices, for distribution. Possibly, the best mode of proceeding at present for a specialist who wants a particular paper is for him to apply to the author on the chance of his having these extra copies.

*Botanischer Jahresbericht: Systematisch geordnetes Repertorium der Botanischen Literatur aller Länder.* Herausgegeben von Dr. Leopold Just. (Berlin: Gebrüder Bertrager, 1873.)

WITH the rapid increase of botanical literature of every kind during the last few years every working botanist must have proved the inconvenience of having no work of reference at hand like this "Botanischer Jahresbuch," and particularly those who are engaged in any special inquiry involving much research and an extensive knowledge of the literature of his subject. As the preface to this excellent *résumé* of the botanical literature of 1873 truly says, "Almost every botanist has passed through the experience of having read through bulky treatises with the expenditure of much time, only to complain that it is so much time lost. On the other hand, it happens frequently enough that very important treatises appear in periodicals where they are not exactly looked for by botanists, and consequently frequently remain unknown and unused for years." This need no longer be the case, if the success which this undertaking thoroughly deserves is granted it, and warrants the continuance of it from year to year.

The work has been published in two half-volumes, and the first part or half-volume summarises the investigations which have been made, and the literature published on the various groups of the Cryptogamia, together with divisions on the morphology of cells, the morphology of tissues, the special morphology of conifers, the morpho-

\* There is an article "Sur l'Hyperocycloïde à trois Rebroussements" in the "Nouvelles Annales" (pp. 21-31), Janvier, 1875.

logy of the Phanerogamia (monocotyledons and dicotyledons), and Physical and Chemical Physiology, continued in the second half-volume, which further contains divisions on fructification and reproduction, hybridation, origin of species. Lists and notices of systematic monographs and extra-European floras stand next in order, together with Paleobotany, treated according to the succession of formations, beginning with the Primary or Palaeozoic formation. The other portions embrace pharmaceutical botany, technical botany, botany applied to forest management, diseases of plants, and geographical distribution.

The aim of the editors has been to give as complete a view as possible of the literature of the several subjects above mentioned, and with regard to most of the departments this has been successfully accomplished, but omissions occur in some of the divisions, particularly in those on the cellular cryptogams and the morphology of tissues. No notice, *e.g.*, is taken of the important work of Strasburger on *Azolla* and the Lycopodiaceæ, nor the work of Juranyi on the spores of *Salvinia natans*. Some of the omissions Dr. Just promises to rectify in the next year's volume.

In this deficient section, however, it may be observed that all newly constituted species amongst the Diatomaceæ and fungi are carefully noted, and of the latter brief descriptions are given. As an appendix to the fungi appears a section on the nutrition of the lower organisms.

The above-mentioned divisions of the work embrace all that has been published in the time specified (1873) in the German, French, and English languages. The literature of other countries is treated in special sections, each under the care of an editor chosen for the purpose; viz., Dutch, Italian, Russian, and Hungarian botanical literature. Dr. Just laments that it has not been possible to include the literature of Denmark, Norway, and Sweden in this first volume. This, however, will not be omitted in future volumes, a suitable editor having been chosen for the purpose.

#### LETTERS TO THE EDITOR

[The Editor does not hold himself responsible for opinions expressed by his correspondents. Neither can he undertake to return, or to correspond with the writers of, rejected manuscripts. No notice is taken of anonymous communications.]

##### Sub-Wealden Exploration

IN NATURE, vol. xi. p. 267, the Rev. J. F. Blake calls attention to the announcement that it is proposed by the Sub-Wealden Exploration Committee to abandon the present bore-hole and to begin again near the same spot. He asks why should not another spot be chosen; and suggests that it would be advisable to bore much more to the north-east, because there the Palaeozoic rocks would be nearer the surface, and because at the present hole we have already learnt all that is necessary. May I be permitted to reply to these remarks?

In the first place, it should not be forgotten that to search for coal measures, or even for the Palaeozoic rocks, is only one object of the exploration. In a purely scientific point of view, it is as important to determine the thickness and character of the Oolitic strata—so far removed from their surface outcrop—as it is to reach the older rocks. If it be true that the boring has been put down where the Oolitic series is well developed, then this object will be the better attained.

But there is even now no proof that the Palaeozoic rocks must necessarily be very deep at Netherfield. We are not entitled to infer from the great development of any one member of the Oolitic series that the lower members will also be well developed at that spot. The Oolitic rocks in the Boulonnais come on in force as we recede from the Palaeozoic area of Marquise. The Kimmeridge clay is well developed in the Pays de Bray; it is 1,000 feet thick near Rouen, and, on its outcrop to the southwest of that city, is underlain by Lower Oolites. One might therefore well have supposed that in the Pays de Bray there

would be a considerable thickness of Oolitic strata over the Palaeozoics; but a boring there proved the carboniferous limestone at 59 feet from the surface.

It is generally conceded that if the sole object of the exploration were to search for coal measures under the south-east of England, it might have been advisable to bore more to the north or north-east. There is no doubt that the Oolitic strata is thin in that direction, so that a boring between Maidstone and Folkestone would probably not meet with any, or with only a small thickness. But, on the other hand, the Lower Cretaceous strata might there be thick. Borings for water at Maidstone have been carried to 600 feet below sea-level, and only just pierced the Weald clay, getting water from the top beds of the Hastings sands. A boring at Ashford, carried to about the same depth, seems to have got into the Hastings sand series; but how much more Wealden strata may be below either of these bore-holes we cannot tell. Prof. Prestwich supposes that the Palaeozoics may lie at a more moderate depth below the sea-level at Folkestone; and he proposes that the Channel Tunnel should be carried through these old rocks. We must all hope, and I for one believe, that the Tunnel can be successfully carried through the chalk; but if this should fail, it is probable that borings will be made to test the feasibility of Prof. Prestwich's scheme. Meanwhile, the Sub-Wealden Exploration can apply its funds in investigating other districts.

It should be remembered that the boring has been mainly supported by landowners and others connected with Sussex. Mr. Willett, the indefatigable secretary, has worked at the task that Sussex may have the honour of leading in an exploration which in future years, whatever may be the success of the present boring, will certainly be extended to other districts in the south-east of England. It is certain that no other spot in Sussex is so well suited for the work; and, all things considered, the best plan is to begin again on the same site.

The Committee has always kept the coal question in the background, preferring to urge forward the work on its scientific merits. Still, it is true that the chief cause of the wide interest taken in the boring is the hope that coal will be found, or at least that valuable information bearing on the point will be obtained. It may then be well again to call attention to the fact that Prof. Gosselet, whose researches on the Coal Measures of Northern France are so well known, believes that the boring is in the right position, and that it is very probable that a line of productive coal measures underlies the Weald. He has shown that the coal beds of Hardingham, in the Boulonnais, are really true coal measures faulted down, and are not an abnormal development of the limestone series; a conclusion with which other geologists now agree.

I have entered into these long explanations from a fear lest Mr. Blake's well-meaning criticisms may convey the impression that money is now to be spent at Netherfield which could be better spent elsewhere. I think this is not the case, and I hope that those who have the means and the will may see the importance of aiding the work with their contributions. Mr. H. Willett (Arnold House, Brighton) has made himself personally responsible for the amount (600*l.*) needed to carry the new boring down to 1,000 feet, trusting that subscriptions will steadily come in for the future as they have done in the past.

Geological Survey Office, Jermyn Street, W. TOPLEY  
London, Feb. 7

### Gaussian Constants

PROF. HUMPHREY LLOYD says, in his book "On Magnetism," published about two months ago, and reviewed (vol. xi. p. 221) in NATURE by Prof. Balfour Stewart, on page 115, in a paragraph on "Gauss's Theory"—"In addition to this, mainly through the exertions of General Sabine, magnetical observations have been vastly multiplied at other points of the earth's surface; and the time has consequently arrived when a re-calculation of the Gaussian constants, as they are called, may with advantage be undertaken. This laborious work is now in progress. General Sabine has completed the co-ordination of the observations, and Prof. Adams has generously offered to devote his valuable time to the re-calculation based upon them. The scientific world may therefore, before long, expect to see a series of charts exhibiting the actual condition of the earth's magnetism greatly more exact than any which have been yet produced." It may therefore interest Prof. Lloyd and others to hear that

about nine months ago was edited and published at Berlin, at the request of the Imperial Admiralty, "Die Grundlagen der Gaussischen Theorie und die Erscheinungen des Erdmagnetismus im Jahre 1829, mit Berücksichtigung der Secularvariationen aus allen vorliegenden Beobachtungen berechnet und dargestellt, von A. Erman und H. Petersen;" a re-calculation of the "Gaussian Constants," based on a co-ordination of the most reliable observations, containing a series of charts which exhibit the actual condition of the earth's magnetism.

O. REICHENBACH

### Columnar Formation in Mud Banks

IN reference to the report in NATURE, vol. xi. p. 258, on Mr. Mallet's communication to the Royal Society, respecting the hexagonal crystallisation of basalt, I beg to offer to your readers a similar explanation of the columnar formation in some mud banks on the shores of some of the rivers in South Africa.

The modern channels are gradually becoming lower than formerly, owing to the rising of the land, and so the streams in estuaries and reaches have cut out deeper courses in the previously formed muddy bottoms, and these are now exposed on the sides of the rivers, but at the bottom of the valleys, to the action of the sun and the hot winds. These strata of mud are very thick, and they begin to dry on the surface, and split across into hexagonal-like discs all over the flat, and this splitting, on the surface gradually deepens into the stratum, and a mass or congeries of columns is thus formed on the side lying nearest the river. The diameter of these columns may vary from 4 to 9 inches, but their length is very uncertain, and might be from 1 to 3 feet. These again become detached by gravity, rains and winds, and tumble into the stream, and are borne away by the currents to the sea, to become imbedded and fossilised in some sand-bank, and probably the study of some future paleontologist.

In the case of basalt the agency of crystallisation is stated to be by Mr. Mallet the abstraction of heat and contraction of fluidity into solidity; but in this case it may be attributed to loss of moisture by heat and dryness producing contraction of fluidity into solidity. A similar result would therefore appear to be produced by apparently two opposite causes, cooling in the one case and heating in the other, but both have tended to produce a closer aggregation of the molecules, and brought them within the range of their peculiar physical affinities.

Edinburgh

J. W. BLACK

### Flowers and Bees

WITH reference to a letter which appeared in NATURE, vol. xi. p. 248, I may mention that on the 30th of August last nearly all the Snapdragon flowers I could find (including many unopened buds) had been bitten through by bees. I had been looking out for flowers in this state a short time before (I think not more than a week), when I could find only two, and those looked as if they might have been accidentally injured. The quickness and thoroughness with which the work had been done was very striking.

C. A. M.

### Iron Pyrites

IN NATURE, vol. xi. p. 249, Mr. Carr mentions the fact that some iron pyrites in the Maidstone Museum "have crumbled into a coarse, finely divided mass;" and he inquires whether "such a thing has ever been observed before." It is a very common and well-known fact, and any work on chemistry will explain it. Perhaps we can best answer the question by quoting Dr. Miller on the subject (Chemistry, p. 538):—"Some varieties of iron pyrites, especially those found in the Tertiary strata, are speedily decomposed by exposure to air; oxygen is absorbed, and ferrous sulphate formed. This decomposition occurs with greater facility if the disulphide be mixed with other substances, as is the case in the aluminous schists; in which, by the further action of air, a basic ferric sulphate is formed, whilst the liberated sulphuric acid reacts upon the alumina, magnesia, or lime of the soil, and forms sulphates; those of aluminium and magnesia may be extracted by lixiviation. The ordinary crystallised pyrites from the older strata is not thus decomposed, but a variety of a whiter colour is disintegrated rapidly by exposure to the weather; this form of pyrites is known as *Marcastite*, or *white iron pyrites*."

R.

## The Micrographic Dictionary—Pollen Grains

I READ your criticism of this book in last number of NATURE with a good deal of interest, and I fully agree with your reviewer in his statement that "workers in different fields will place a different estimate on the importance of their own department." Allow me to call your attention to the two singularly erroneous figures of the pollen grains of *Minutus moschatus* (Pl. 32, Fig. 24) in this work. I have frequently examined the pollen of this plant, and have never seen it anything like the figures in the "Dictionary," or in any way differing from the grains of many other members of the Scrophulariaceæ. The pollen of *M. moschatus* is like a grain of wheat, and not like the wonderful convolute ball shown in the "Dictionary."

In his "Common Objects for the Microscope," Plate 3, Fig. 21, the Rev. J. G. Wood reproduces the first of these two extraordinary figures, and describes the pollen as "belted with wide and deep bands," &c., but by an oversight he omits to give the source from which the erroneous figure is copied.

In his "One Thousand Objects for the Microscope," Plate 2, Fig. 6, Mr. Cooke copies the second extraordinary figure of this pollen, and says, "these curious granules resemble a band or cord rolled or folded in a spherical mass," as if he had so seen them. The "Dictionary" plate certainly does look like this, but in the letter-press the folds are referred to as "slits or furrows." By an oversight Mr. Cooke also omits to give the source from which his erroneous figure is copied.

W. G. SMITH

## The Phylloxera

IN the report to the Department of the Interior of the Canton of Geneva by the commission appointed to inquire into the best means of stopping the ravages of Phylloxera, which I have just received from Prof. Forel, of Morges, it is stated that the insect was most probably introduced from England in some vines which were taken to Geneva to certain graperies of Baron Rothschild in 1869. These graperies are in the middle of the infected district—they were found to be infected within twelve months of the arrival of the plants, and no vineyards but those in the neighbourhood of these graperies have been infected in all Switzerland. Prof. Forel, in his letter to me, says that while the surrounding vines have perished, those attacked in Baron Rothschild's houses have suffered very little indeed, and bear plenty of fruit. These vines, he says, are Black Hamburg and Muscat d'Alexandrie or d'Alicante. He asks if in England anything is known which points out any kind of vine as suffering less than other kinds. Can any of your readers tell me anything about it?

Clifton, Jan. 23

G. H. WOLLASTON

## Thermometer Scales

I SHALL feel greatly obliged if any reader of NATURE can inform me what scale the thermometer referred to in the following extracts was made to — "7 Feb., 1775. This day the thermometer was down to 80, two hours after sunrise." "This thermometer has five inches divided into 75 degrees above temperature (*sic*); and 6½ inches below temperate, divided into 100 degrees; the spirit at 80 was about an inch from the bottom. In the frost in 1739 the spirit sunk below all the marks in this thermometer." Also—"Dec. 30, 1739. Thermometer sunk below all the marks. . . . This thermo was marked down to 7 below Fahrenheit's freezing point of 32; so this was below 25 of Fahr." Some very hot days in July 1757 are marked (I presume by the same thermometer) at 40, 41, 46, and 47 degrees; another day, "very near 50" is spoken of as the hottest day the writer thinks he ever remembers in England, "except the famous hot Saturday on the 11th of June, 1748."

In 1783-4, 13 below 0 of *Linnaeus* is mentioned as very severe cold. The scale of *Linnaeus* is mentioned several times. I have failed to discover the scale of the first thermometer, and never heard of that of *Linnaeus*. If any of your readers can enlighten me as to the relation of these scales to that of Fahrenheit or Réaumur, I shall feel greatly indebted.

Norwich, Feb. 1

THOMAS SOUTHWELL

## OUR ASTRONOMICAL COLUMN

THE NEXT RETURN OF HALLEY'S COMET.—In the year 1864 the late Count G. de Pontécoulant made an important communication to the Paris Academy of

Sciences relating to the perturbations of this famous comet. He remarked at the outset: "I propose, in my new researches on the comet of Halley, to follow the course of that body from the epoch when it was observed for the first time in a manner sufficiently precise to allow of determining the orbit, until that of its next return to perihelion, which will take place in 1910, *i.e.* during an interval of nearly three hundred and eighty years, including five entire revolutions of the comet. I shall describe here, as succinctly as it is possible to do, the results of the immense calculations which it has been necessary to effect in order to attain this object." We shall confine ourselves in the present remarks to a few particulars relating to the appearance of the comet in 1910, reserving a further account of Pontécoulant's memoir for a future occasion. It is, however, impossible to avoid an expression of regret that the astronomer who has completed the enormous work indicated in the above extract, should have passed away without (so far as we know) putting upon record the successive steps of his calculations in sufficient detail to be of service to the future investigator, and it is to be hoped his papers may yet be made available for this purpose. Mere statements of final results, necessitating for their attainment such a prodigious amount of labour and such unusual skill, are hardly all that is required, though in this remark we imply no want of confidence in the accuracy of the work performed. It is almost certain that the perturbations of Halley's comet will be recomputed before the year of its next return, and it is as certain that the possession in detail of the various numerical results of Pontécoulant's work would be of very great service to anyone who may undertake its verification, not only by way of check as he proceeds, but as a guide to the effective management of the formidable mass of figures involved.

The perihelion passage in 1835 is fixed to Nov. 15/95 Paris mean time, at which moment the comet is found to have been moving in an ellipse with a period of 27895/81 days. The influence of the planet Jupiter upon the length of the present revolution is greater than in any of the four previous ones, and amounts to 679/37 days, by which the next perihelion passage is accelerated. Saturn retards the comet 2/79 days, while Uranus accelerates it 2/30 days, therefore nearly negating the influence of Saturn. The attraction of other planets is neglected. The total effect of perturbation during the actual revolution is thus found to be 678/88 days, the period being shortened thereby; and hence the time of revolution corresponding to 1835, Nov. 16, is diminished to 27216/93 days, and the next perihelion passage is consequently fixed to 1910, May, 23/87 Paris time, the comet then completing the shortest revolution since 1531, the preceding revolution having been the longest, and their difference is upwards of two years. The periodic time corresponding to the comet's motion at perihelion in 1910 is 27,790 days. A notable change is produced by the action of the planet Jupiter in the perihelion distance, which is increased by upwards of a tenth of the earth's mean distance from the sun, and the comet's orbit is thus brought into very close proximity to that of the earth at the descending node. In 1835 the comet at this point passed 0/1511 from our track; in 1910, according to Pontécoulant, it will be distant only 0/0157. The eccentricity of the orbit in 1910 is found to be 0/9017332; the semi-axis major, 17/95546; the longitude of perihelion, 305° 38' 14"; the ascending node, 57° 10' 33"; inclination, 17° 46' 51"; the motion is retrograde. The longitudes are counted from the mean equinox at perihelion.

The track of the comet calculated from these elements is a very favourable one for observation. At the end of October 1909 the comet has the same theoretical intensity of light as when it was last glimpsed by Dr. Lamont with the Munich refractor, on the 17th of May, 1836. (It is often erroneously supposed that the last observations

were made at the Cape of Good Hope.) Its position, according to the above data, is in the neighbourhood of 130 Tauri. Thence retrograding with a slow southerly motion in declination, it passes through the constellation Aries, in January 1910, and is situate in Pisces until it has approached our globe within the mean distance of the earth from the sun, or until about the beginning of the last week in May. Its apparent motion then rapidly accelerates. On June 12 the calculated position is close to the bright star Capella, and, five days later, on the confines of Lynx and Leo Minor. At this period the comet attains its least distance from the earth, which may be taken as 0.25. Descending pretty quickly towards the equator, we find it in the neighbourhood of 84 Leonis at the beginning of July, afterwards gradually losing itself in the evening twilight. With the date for perihelion passage assigned by Pontécoulant, the comet would be most conspicuous in the first half of the month of June, in the absence of the moon, which is full on the 22nd.

ENCKE'S COMET has been detected very close upon the calculated position at more than one of the private observatories in this country, but up to the interference of moonlight was extremely faint. We shall continue the ephemeris next week.

ANTARES.—The measures of this star communicated last week by Mr. J. M. Wilson, of Rugby, are pretty conclusive as to a physical connection of the components. If the angle and distance used as a starting-point (1848) in our former notice be brought up to Mr. Wilson's epoch, 1873.42, by applying Leverrier's proper motions in the interval to the place of the large star, we have

Angle . . . . . 287° 8. Distance . . . . . 3" 53.

The observation gives the angle 268° 6 (differing 19°) less than any yet assigned by previous measures; but in 1845, Mitchel thought the small star was on the parallel preceding, and all subsequent observations except the one in question have placed the companion in the *n.p.* quadrant, Dawes in 1864 finding the angle nearly 276°.

LALANDE'S ÉTOILE SINGULIÈRE.—On the 4th of March, 1796 ("Histoire Céleste," p. 211), Lalande observed meridionally a star of 6.7 magnitude, the position of which for the beginning of the present year is in R.A. 8h. 13m. 3s., N.P.D. 68° 51' 5; on the 15th of the same month he again observed the star, and the resulting places for 1800 belong to Nos. 16292-3 of the reduced catalogue. On March 4 he attaches this remark to his observation—"Étoile singulière." The observation of the 15th is without note. We have examined this star telescopically on several occasions, without being able to detect any unusual appearance about it. The light is yellowish. Has any reader of NATURE had the curiosity to look at it? The remark is a strange one for the observer of 50 many thousands of stars to attach, unless there was really something singular in the star's aspect at the time.

#### NEWS FROM THE "CHALLENGER"\*

THE *Challenger* left Port Nicholson on the 7th July, 1874, and proceeded under sail along the east coast of New Zealand. On the 8th we rounded and trawled in 1,100 fathoms, lat. 40° 13' S., long. 177° 43' E., with a bottom-temperature of 2° C., and a bottom of soft greenish ooze. Many animals were brought up by this trawl, resembling closely those which we had taken at a corresponding depth in other portions of the Southern Sea. On the 10th we again trawled and sounded in 700 fathoms about forty miles to the east of East Cape.

We then continued our course northwards towards the

\* Report on the Cruise of H.M.S. *Challenger*, from July to November 1874, by Prof. Wyville Thomson, F.R.S., Director of the Civilian Scientific Staff. A paper, dated H.M.S. *Challenger*, Hong Kong, read before the Royal Society, Feb. 4.

Kermadec Islands, and on the 14th we took our usual series of observations midway between Macaulay and Raoul Islands in the Kermadec group. At this station we trawled at a depth of 630 fathoms; and we were greatly struck with the general resemblance between the assemblage of animal forms brought up in the trawl and the results of a good haul in about the same depth off the coast of Portugal or North Africa. Among the more interesting objects were a very large and splendid specimen of a Hexactinellid sponge allied to *Poliopegon*, several other fine sponges referred to the same group, and three or four examples of two species of *Pentacrinus* new to science, resembling generally *P. asteria*, L., from the Antilles. We trawled on the following day in 600 fathoms, forty-five miles to the north of Raoul Island, with nearly equal success. On the evening of Sunday the 19th we arrived at Tongatabu and called on the principal missionary, Mr. Baker, from whom we received every possible attention during our short stay. After spending two days in visiting different parts of the island, we left Tongatabu on the 22nd of July, and after taking a few hauls of the dredge in shallow water we proceeded towards Kandavu in the Fijis. On the 24th we stopped off Matuku Island and landed a party of surveyors and naturalists; and while they were taking observations and exploring on shore we trawled in 300 fathoms, and received among other things a fine specimen of the pearly Nautilus, *Nautilus pompilius*, which we kept living in a tub for some time in order to observe its movements and attitudes.

On Saturday the 25th of July we arrived at Kandavu, on the 28th we went to Levuka, and we returned to Kandavu on the 3rd of August, where we remained until the 10th.

At Fiji the civilian staff were occupied in examining the reefs and generally in observing the natural history of the islands; and in this we received all friendly assistance from H.M. Consul, Mr. Layard, and from Mr. Thurston, Minister of King Cacobau. During our stay, a mixed party of naval and civilian officers went in the ship's barge to Mbaw and visited the king.

Between New Zealand and the Fiji group only two soundings were taken to a greater depth than 1,000 fathoms. Of these, one at a depth of 1,100 off Cape Turnagain, New Zealand, gave a bottom of grey ooze, and a bottom-temperature of 2° C.; and the second at 2,900 fathoms, lat. 25° 5' S., long. 172° 56' W., midway between the Kermadecs and the Friendly Islands, gave "red clay," and a temperature of 0.5° C. Four serial temperature-soundings were taken; and the distribution of temperature was found to correspond in its main features with what we had previously met with in oceans communicating freely with the Antarctic Sea.

The dredgings, which, with the exception of one near the New Zealand coast, were all at depths varying from three to six hundred fathoms, yielded a great number of very interesting forms; but, as I have already remarked, they tended to confirm our impression that even at these comparatively moderate depths, at all depths, in fact, much greater than a hundred fathoms, while species differ in different localities, and different generic types are from time to time introduced, the general character of the fauna is everywhere very much the same.

On the 10th of August we left Kandavu and proceeded towards Api, one of the least known of the New Hebrides, where there is as yet no permanent missionary station. On the 12th we sounded and trawled in 1,350 fathoms, with a bottom of reddish ooze; we sounded again on the 15th in 1,450 fathoms with red clay; and on the 18th, after passing through the channel between Makuru and Two-Hill Islands, we stopped off Api in twenty-five fathoms, close to the edge of the reef and opposite a landing-place.

In order to receive, as far as we could, the good-will of



the natives, Capt. Nares had given a passage to eleven Api men, who had been employed for a three-years' term in Fiji under the arrangement which exists there for the regulation of Polynesian labour. Two or three of us, with an armed party, took the returned labourers ashore; and as the natives, although they appeared somewhat mistrustful, and were all armed with clubs and spears and bows with sheaves of poisoned arrows, were sufficiently friendly, nearly all the officers landed and spent a few hours rambling about the shore. It was not thought prudent to go far into the forest, which was very dense and luxuriant, and came close down to the beach.

The natives were almost entirely naked, and certainly bore a very savage and forbidding aspect. One of them was manifestly greatly superior to the others, and appeared to exercise a considerable influence over them. He wore trousers and a shirt and a felt hat, and could speak English fairly. He recognised me at once as having seen me at the sugar plantation in Queensland, where he had been for the usual three-years' engagement, and showed me, with great pride, a note from his former employer, saying that the bearer was anxious to return to his service, and that he would willingly pay his passage money and all expenses in case of his being given a passage to Brisbane. I had been paying some attention to the South Sea labour question, and had formed a very strong opinion of the value to the inhabitants of these islands of the opportunity given them by this demand for labour, of testing their capacity to enter into and mix with the general current of working men, and thereby possibly avoid extermination; and I was greatly pleased to see the result in this instance.

From the island of Api we shaped our course to the north-westward towards Raine Island in a breach of the great barrier reef not far from the entrance of Torres Strait. On the 19th of August we sounded, lat.  $16^{\circ} 47' S.$ , long.  $165^{\circ} 20' E.$ , at a depth of 2,650 fathoms, with a bottom of "red clay," and a bottom-temperature of  $1^{\circ} 7 C.$  ( $35^{\circ} F.$ ). A serial temperature-sounding was taken to the depth of 1,500 fathoms, and it was found that the minimum temperature ( $1^{\circ} 7 C.$ ) was reached at a depth of 1,300 fathoms, and that consequently a stratum of water at that uniform temperature extended from that depth to the bottom.

Serial temperature-soundings were taken on the 21st, the 24th, the 25th, the 27th, and the 28th of August, in 2,325, 2,450, 2,440, 2,275, and 1,700 fathoms respectively; and in each case the minimum temperature of  $1^{\circ} 7 C.$ , or a temperature so near it as to leave the difference within the limit of instrumental or personal error of observation, extended in a uniform layer, averaging 7,000 feet in thickness, from the depth of 1,300 fathoms to the bottom.

It will be seen by reference to the chart that on our course from Api to Raine Island we traversed for a distance of 1,400 miles a sea included within a broken barrier, consisting of the continent of Australia to the west; the Louisiade Archipelago, the Solomon Islands, and a small part of New Guinea to the north; the New Hebrides to the east; and New Caledonia and the line of shoals and reefs which connect that island with Australia to the south. The obvious explanation of this peculiar distribution of temperatures within this area, which we have called for convenience of reference the "Melanesian Sea," is that there is no free communication between this sea and the outer ocean to a greater depth than 1,300 fathoms, the encircling barrier being complete up to that point.

The "Melanesian Sea" is in the belt of the S.E. trade-winds, and the general course of a drift-current which traverses its long axis at an average rate of half a knot an hour is to the westward; evaporation is, as it is usually throughout the course of the trade-winds, greatly in excess of precipitation, so that a large amount of the surface-

water is removed. This must, of course, be replaced, and it is so by an indraught of ocean-water over the lowest part of the barrier at the proper temperature for that depth. We had previously found a temperature of  $1^{\circ} 7 C.$  at a depth of 1,300 fathoms on the 16th, the 19th, and the 21st of June between Australia and New Zealand, on the 17th of July in lat.  $25^{\circ} 5' S.$ , long.  $172^{\circ} 56' W.$ , and earlier on the 10th of March in lat.  $47^{\circ} 25' S.$  The bottom within the Melanesian Sea may be described generally as "red clay," with a small but varying proportion of the shells of Foraminifera, sometimes whole but more usually much broken up and decomposed. In one or two soundings the tube showed curiously interstratified deposits, differing markedly in colour and in composition. The trawl was sent down on the 25th of August to a depth of 2,440 fathoms. The animals procured were few in number—some spicules of Hyalonema, a dead example of *Fungia symmetrica*, two living specimens of a species of *Umbellularia*, which appears to differ in some respects from the Atlantic form, and a very fine and perfect *Brisinga*, also living. The existence of animal life is therefore not impossible in the still bottom-water of such an enclosed sea; but, as we have already seen in the Mediterranean, the conditions do not appear to be favourable to its development. On the 29th of August we trawled in 1,400 fathoms, about 75 miles to the east of Raine Island, with somewhat greater success. This might have been anticipated, as the depth was not much greater than that at which the free interchange of water was taking place, and diffusion and intermixture was no doubt much more rapid than at the bottom.

On the 31st of August we visited Raine Island, which we found to correspond in every respect to Jukes's description in the "Voyage of the *Fly*." We observed and collected the species of birds which were breeding there. In the afternoon we dredged off the island in 155 fathoms with small success, and proceeded towards Port Albany, Cape York, where we arrived on the 1st of September.

We left Somerset on the 8th, and proceeded across the Arafura Sea to the Arú Islands, reaching Dobbo on the island of Wamma on the 16th. We found no depth in the Arafura Sea greater than 50 fathoms, and the average depth was from 25 to 30 fathoms. The bottom was a greenish mud, due apparently in a great degree to the deposit from the great rivers of New Guinea and the rivers falling into the Gulf of Carpentaria. Animal life was not abundant. Many of the animals seemed dwarfed, and the fauna had somewhat the character of that of a harbour or estuary. The specific gravity of the surface-water was unusually low, falling on the 23rd off Dobbo Harbour to  $1^{\circ} 02505$ ; the temperature reduced to  $15^{\circ} 5 C.$ , distilled water at  $4^{\circ} C. = 1$ .

After spending a few days shooting Paradise Birds and getting an idea of the natural history of the island of Wokaw, we left Dobbo on the 23rd and proceeded to Ké Doulan, the principal village in the Ké group. We then went on to the island of Banda, where we remained a couple of days, and thence to Amboina, which we reached on the 4th of October.

On the 20th of September, after leaving the Ké islands, we sounded and trawled in 129 fathoms. The trawl brought up a wonderful assemblage of things, including, with a large number of Mollusca, Crustacea, and Echinoderms of more ordinary forms, several fine examples of undescribed Hexactinellid sponges, and several very perfect specimens of two new species of *Pentacrinus*. Temperature-soundings were taken on the 28th of September and on the 3rd of October at depths of 2,800 and 1,420 fathoms respectively, and on both occasions the minimum temperature ( $3^{\circ} C.$ ) was reached at a depth of 900 fathoms, indicating that the lowest part of a barrier inclosing the Banda Sea, bounded by Taliabo, Buru, and Ceram on the north, the Arú islands on the east, Timor and the Serwatty islands on the south, and Celebes and the shoals

of the Flores Sea on the west, is 900 fathoms beneath the surface.

From Amboina we went to Ternate, and thence across the Molucca passage and into the Celebes Sea by the passage between Bejaren Island and the north-east point of Celebes. On the 13th we trawled and took serial temperatures near Great Tawallie Island. The trawl brought up several specimens of a very elegant stalked halichondroid sponge new to science, and the thermometer gave temperatures sinking normally to a bottom-temperature of  $2^{\circ}04$  C. On the following day we sounded in 1,200 fathoms, with again a normal bottom temperature of  $1^{\circ}9$  C. It seems, therefore, that the Molucca passage communicates freely with the outer ocean; it does so at all events to the depth of 1,200 fathoms, and most probably to the bottom, if it include greater depths.

In the Celebes Sea we had two deep soundings on the 20th, to 2,150 fathoms, and on the 22nd to 2600 fathoms. On both occasions serial temperature-soundings were taken, and on both the minimum temperature of  $3^{\circ}7$  C. ( $38^{\circ}7$  F.) was reached at 700 fathoms. A passage of this depth into the Celebes Sea is therefore indicated very probably from the Molucca passage. This temperature corresponds almost exactly

with that taken by Capt. Chimmo in the same area. We trawled on the 20th, and although the number of specimens procured was not large, they were sufficient to give evidence of the presence of the usual deep-sea fauna.

We reached Zamboanga on the 23rd, and on the 26th we passed into the Sulu Sea and trawled at a depth of 102 fathoms. On the 27th we sounded to 2,550 fathoms, and took a serial temperature-sounding. A minimum temperature of  $10^{\circ}$  C. was found at 400 fathoms, so that the Sulu Sea must be regarded as the fourth of this singular succession of basins cut off by barriers of varying height from communication with the ocean. This observation in the main confirmed those of Capt. Chimmo in the same locality. The minimum temperature reached was the same in both, but we appear to have found it at a somewhat higher level.

We arrived at Ilo Ilo on the 28th, and proceeded by the eastern passage to Manila, which we reached on the 4th of November.

The collections have been packed and catalogued in the usual way, and will be sent home from Hong Kong. We have had an opportunity during this cruise of making a very large number of observations of great interest. I believe I may say that the departments under my charge are going on in a very satisfactory way.

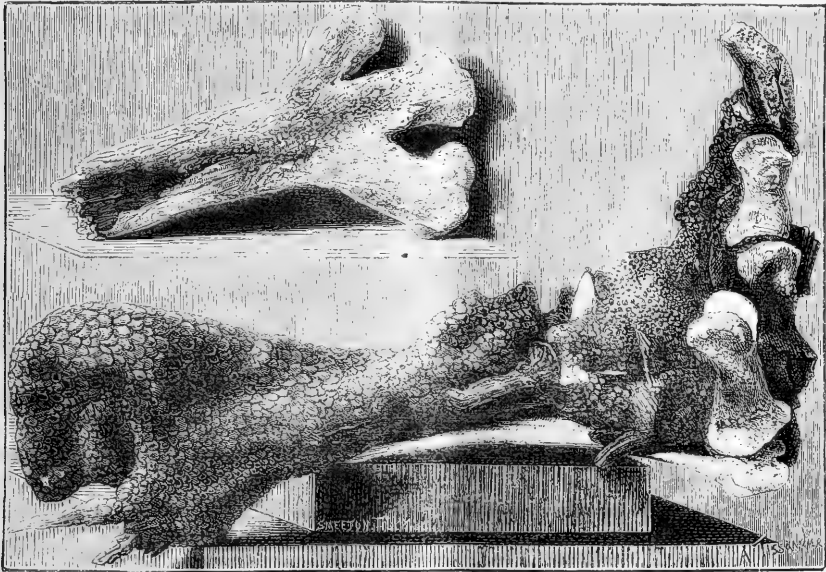

Moë Remains.

#### THE MOAS OF NEW ZEALAND

QUITE recently rumors have reached us from New Zealand to the effect that two living specimens of the colossal struthious birds, the Moas, have been captured in the province of Otago, which are to be taken to Christchurch. That the genus *Dinornis*, to which they belong, has been extinct for some time is the general impression, and it is based on evidence of no inconsiderable weight. Nevertheless, there are many reasons for the belief that

it is not long since individuals of that ostrich-like group peopled parts of New Zealand. In 1870 Dr. Haast discovered kitchen-middens made up of fragments of Moas of different species, mixed up with bones of seals, dogs, and gulls, together with pieces of chalcedony, agate, &c., which evidently indicate that these gigantic birds were contemporaneous with the ancient human inhabitants of the islands. A human skeleton having been found with a *Dinornis* egg between its arms is also evidence in the same direction, as is the recent discovery of the neck of

one of these birds with the muscles and integuments preserved.

Several portions of the external covering of the bird have also been discovered, along with bones, which show signs of recent interment. Beside feathers, the complete skeleton in the museum at York has the integument of the feet partly preserved, from which it is evident that the toes were covered with numerous small hexagonal scales. We are now able to supplement our knowledge with a description of the covering of the tarsus from a specimen sent by Dr. Haast to Prof. Alphonse Milne-Edwards, which is to be seen in the Museum of Natural History at Paris. This specimen is figured, one-fourth the natural size, in the accompanying drawing, for which we have to thank the proprietors of our enterprising French namesake *La Nature*. It was obtained at Knobly Range, Otago, and belongs to the species *Dinornis ingens*. From it we learn that the tarsus, as well as the toes, was nearly entirely covered with small horny imbricate scales, and not with broad transverse scutes, as it might quite possibly have been. It is also evident that the hind toe, or hallux, which is not present in either the Ostrich, Rea, Emu, Cassowary, nor in some species of Moas, was articulated to the metatarsal segment of the limb a little above the level of the other toes. Those species of *Dinornis* which possess the hind toe, Prof. Owen includes in the genus *Palapteryx*.

Amongst the struthious birds, the Moas agree most with the Apteryx, in the presence (occasionally) of a fourth toe; and in their geographical distribution. They resemble the Cassowaries and the Emus most in the structure of their feathers; and in the structure of the skull differ from all to an extent which has made Prof. Huxley arrange them as a separate family of the Ratites. A knowledge of the anatomy of their perishable parts would be an invaluable assistance in the determination of their true affinities, but it is almost too much to hope that the material for such an investigation will ever present itself.

### THE RECENT STORMS IN THE ATLANTIC

THIS subject has attracted the notice of the *New York Herald*, which, in an article on the 23rd January, remarks that "the successive gales appear to have been connected with the high barometer or polar air-waves which have recently swept across the northern part of the United States." Our contemporary says, moreover, that the last "great barometer fluctuation was followed by a storm centre which the weather reports recorded on the 19th inst. as then moving eastward over the Gulf of St. Lawrence. . . . In fact, the lesson apparently deducible from the recent steamer detentions and ship disasters we had to record is, that the severest cyclones may be looked for as the sequel phenomena of the great winter areas of high barometer and intense cold; or, in other words, the rising glass should be studied by the seaman as carefully as the falling glass."

Certainly, there is some truth in this assertion; but our contemporary ignores the startling fact that at the very same moment we had in Europe low pressure, southern gales, and high temperature. On the 15th a strong south-westerly gale was raging at Valencia. Evidently the danger is very great when a rising barometer in America is coupled with a falling barometer in Europe, or *vice versa*.

Unhappily, the Transatlantic Telegraph is not in use now for sending meteorological summaries between Europe and America. It is deeply to be regretted that the practice was discontinued, and we hope the recent disastrous gales will induce the nations on both sides of the great ocean to neglect no longer that useful channel of mutual information.

W. DE FONVILLE.

### THE PAST AND FUTURE WORK OF GEOLOGY\*

ON the 29th ult. Prof. Prestwich, who, as our readers know, has succeeded the late Prof. Phillips in the chair of Geology at Oxford, gave his inaugural lecture in the Museum of the University. He commenced by paying a high and well-merited tribute to the value of the work, the wide attainments and character of his predecessor, Prof. Phillips, and giving a brief sketch of the aspect of geological science at the time the chair was established. Prof. Prestwich then proceeded to notice some of the larger features, whether on questions of theory or on questions of fact, by which the progress of geology has been marked, and which, while they may serve to show how much has been done, will yet indicate how much still remains to be accomplished.

"The geologist commences," Prof. Prestwich said, "where the astronomer ends. We have to adapt the large and broad generalisations of cosmical phenomena to the minutest details of terrestrial structure and constitution, which it is our business to study. The common origin of the solar system has been long inferred from the spheroidal figure of the earth and the relations of the planets to one another, and explained by evolution from an original nebulous mass; and geologists have had to consider how far such a hypothesis is in accordance with geological facts. The questions connected with the earliest stages of the earth's history are on the very boundary line of our science, but they have too important a bearing on its subsequent stages not to command our serious attention; and though obscure and theoretical, they serve to guide us to firmer ground. This nebular hypothesis has recently received from physicists corroboration of a most novel and striking character, equally interesting to geologists and astronomers.

"The wonderful discoveries with respect to the solar atmosphere, made by means of the spectroscope, have now presented us with an entirely new class of evidence, which, taken in conjunction with the argument derived from figure and plan, gives irresistible weight to the theory of a common origin of the sun and its planets; and while serving to connect our earth with distant worlds, indicates as a corollary what of necessity must have been its early condition and probable constitution.

"The whole number of known elements composing the crust and atmosphere of the earth, the lecturer went on to say, amount only to sixty-four, and their relative distribution is vastly disproportionate. It has been estimated that oxygen in combination forms by weight one-half of the earth's crust; silicon enters for a quarter; then follow aluminium, calcium, magnesium, potassium, sodium, iron, and carbon. These nine together have been estimated to constitute  $\frac{1}{100}$  of the earth's crust. The other  $\frac{99}{100}$  consist of the remaining fifty-five non-metallic and metallic elements.

"The researches of Kirchhoff, Angström, Thalén, and Lockyer have now made known, that of these sixty-four terrestrial elements there are twenty present in those parts of the solar atmosphere called the "chromosphere" and "reversing layer," as the stratum which surrounds the photosphere is called from certain optical properties. They consist of—

Aluminium.	Chromium.	Lead (?)	Sodium.
Barium.	Cobalt.	Magnesium.	Strontium.
Cadmium.	Copper (?)	Manganese.	Titanium.
Cerium.	Hydrogen.	Nickel.	Uranium.
	Iron.	Potassium.	Zinc.

"Nor, with possibly two exceptions, does the spectroscope give any indication of unknown elements.

"While these phenomena afford such strong additional proofs of the common origin of our solar system, Mr. Norman Lockyer, basing his inquiries upon these and other facts recently acquired

\* Inaugural Lecture of J. Prestwich, F.R.S., Professor of Geology in the University of Oxford. Delivered January 29.

† On analysing this list we find—

1 Permanent Gas . . . . .	Hydrogen.	Potassium.
2 Metals of the Alkalies . . . . .	Sodium.	Strontium.
2 All the Metals of the Alkaline Earths . . . . .	Calcium.	Barium.
3 Metals of the Zinc class . . . . .	Magnesium.	Zinc.
All the Metals of the Iron Class . . . . .	Manganese.	Chromium.
	Iron.	Nickel.
	Tin.	Uranium.
		Titanium.

2 Metals of the Tin class . . . . .

2 Metals of the Lead class (probably)

The metals of the Vanadium, Antimony, Silver, and Gold classes are entirely unrepresented, while, if we except the metallic nature of hydrogen, there is not a single metalloïd on the list, although they have been diligently searched for.

on the constitution of the sun, has been led to form some views of singular interest bearing on the probable structure of the crust and nucleus of the earth. With his permission I am enabled to lay before you some of the points in the inquiry he is now pursuing.

"Observation and theory have both led him to the unexpected conclusion that in the case of an atmosphere of enormous height and consisting of gases and of metallic elements in a gaseous state, gravity overcomes diffusion, and the various vapours extend to different heights, and so practically arrange themselves in layers; and that in the sun, where owing to the fierce solar temperature the elements exist in such a state of vapour and of complete dissociation, the known elements are observed to thin out in the main in the following order\* :—

Coronal Atmosphere . . . . .	Cooler Hydrogen	
Chromosphere . . . . .	Incandescent Hydrogen.	
		Magnesium.
		Calcium.
Reversing layer . . . . .	Sodium.	
	Chromium.	
	Manganese.	
	Iron.	
	Nickel, &c.	

"Mr. Lockyer suggests, and has communicated some evidence to the Royal Society in support of his suggestion, that the metalloids or non-metallic elements as a group lie outside the metallic atmosphere. He also explains why under these conditions their record among the Fraunhofer lines should be a feeble one. Hence he considers that we have no argument against the presence of some quantity of the metalloids in the sun taken as a whole, although that quantity may be small.

"Mr. Lockyer then takes the observed facts together with the hypothesis of the external position of the metalloids, and is considering these two questions :—

1. Assuming the earth to have once been in the same condition as the sun now is, what would be the chemical constitution of its crust ?

2. Assuming the solar nebula to have once existed as a nebulous star at a temperature of complete dissociation, what would be the chemical constitution of the planets thrown off as the nebulosity contracted ?

"It will be seen that there is a most intimate connection between these two inquiries; the localisation of the various elements and the reduction of temperature acting in the same way in both cases.

"Thus to deal with the first question; as the external gaseous vapours (those of the metalloids) cooled they condensed and fell on the underlying layer, where they entered into combination, forming one set of binary compounds, and then others as the temperature was reduced, until finally all the metals and earths were precipitated. †

"If now we turn to the earth's crust we find it very generally assumed that the fundamental igneous rocks which underlie the sedimentary strata, and which formed originally the outer layers, may be divided into two great masses holding generally and on the whole a definite relation one to the other—an upper one consisting of granite and other Plutonic rocks, rich in silica, moderate in alumina, and poor in lime, iron, and magnesia; and of a lower mass of basaltic and volcanic rocks of greater specific gravity, with silica in smaller proportions, alumina in equal, and iron, lime, and magnesia in

\* Mr. Lockyer points out that this order is that of the old atomic or combining weights, and not that of the modern atomic weights, as the following table shows :—

	Old Atomic Weights.	New Atomic Weights.
Hydrogen . . . . .	1	1
Magnesium . . . . .	12	24
Calcium . . . . .	20	40
Sodium . . . . .	23	23
Chromium . . . . .	26	52.5
Manganese . . . . .	27	55
Iron . . . . .	28	56
Nickel . . . . .	29	58

Aluminium does not find a place in the above list, because its order in the layers has not yet been determined by observation, but the principle referred to would place it between magnesium and calcium.

† Firstly, those binary compounds capable of existing at a high temperature, such as the vapour of water, of hydrochloric acid, silica, carbonic acid, and others would be formed; secondly, the precipitation of these would give rise to numerous reactions, forming a variety of silicates, chlorides, sulphates, &c.; thirdly, with the condensation of water the constitution of minerals would be effected, double decompositions would ensue, and the consolidation of the outer shell commence.

much larger proportions, with also a great variety of other elements as occasional constituents; while the denser metals are in larger proportion in the more central portion of the nucleus. The suggestion of Mr. Lockyer is that this order follows necessarily from the original localisation of the earths and metals before referred to, by which the oxygen, silicon, and other metalloids formed, as they now do in the sun, an outer atmosphere, succeeded by an inner one consisting in greater part of the alkaline earths and alkalis, then by a lower one of iron and its associated group of metals, and finally by an inner nucleus containing the other and denser metals.

"As we have before observed, above nine-tenths of the earth's crust consists of those elements which, on the assumption of the external position of the metalloids, would constitute the outer layers of the nebular mass. Thus, oxygen and silicon alone constitute on the average  $\frac{7}{10}$  of the mass of acid Plutonic rocks of which the upper part of the first assumed shell of the earth consists; while beneath it are the basic rocks, into the composition of which calcium, magnesium, and iron, combined with oxygen, enter in the proportion of, say,  $\frac{1}{10}$ , the silica being less by  $\frac{1}{10}$ ; still deeper lie the denser and harder metals, which reach the surface only through the veins transversing the outer layers.

"We next come to the second question dealing with the chemical constitution of the planets. It is imagined that the same consideration would hold good, and that the exterior planets may approach in their constitution that of the sun's outer atmosphere, and that the planets may become more metallic as their orbits lie nearer the central portion of the nebula. Mr. Lockyer considers that the low density and gigantic and highly absorbing atmospheres of the outer planets accord with their being more metalloidal; and that, on the other hand, the high density and comparatively small and feebly absorbing atmospheres of the inner planets, points to a more intimate relation with the inner layers of the original nebulous mass. For the same reason we should expect to find the metalloids scarcer in the sun than in the earth.

"In the Jovian system, and in our own moon, we have a still further support of the hypothesis in the fact that the density of the satellites is less than that of their primary.

"I had hoped," Prof. Prestwich continued, "to have brought before you some of the results of the examination of the spectra of portions of the outer igneous rock crust of the earth, which Mr. Lockyer kindly undertook to compare with the solar spectrum, but, owing to the state of the weather, the investigation is not yet complete. It may, however, be stated that, as in the spectrum of the sun, so in the spectra of the granite, greenstone, and lava already tested, no trace of metalloids is present, although oxygen and silicon are so largely present in these rocks.

"We can, however, still only look on these views as hypothetical, but they commend themselves to us by their simplicity and grandeur, and their high suggestiveness for future inquiry and research. They show us also how the spectroscope may, as the microscope has done already, aid the investigations of the geologist—the one by endowing the eye with new powers of sight with respect to the infinitely minute, and the other with new powers of tangible analysis with respect to the infinitely distant.

"Quitting the early history of our globe, we leave the domain of the astronomer and enter upon one shared by the geologist, the mineralogist, the chemist, and the mathematician. Instead of the sixty-four simple elements, their mutual reactions have resulted in the formation of somewhere about 1,000 varieties of rocks and minerals alone, with which the geologist has in future to deal. He also has to deal with all the physical problems arising from the consolidation of the crust of the earth—from pressure due to gravitation and contraction—from the action of subterranean forces—from the effects of heat—and with all the varied phenomena resulting from these complex conditions."

Mr. Prestwich then referred to the early belief that the thickness of the crust of the earth does not now exceed thirty to sixty miles; and to the conclusion, supported by Sir W. Thomson, of the late Mr. Hopkins, who, reasoning on phenomena connected with precession or nutation, concluded that on the contrary it could not be less than 800 miles thick or more.

Remarking that it is difficult, however, to reconcile these views with the extent and character of modern volcanic action, Prof. Prestwich referred to the theories propounded by Mr. Mallet in his remarkable paper recently published in the Transactions of the Royal Society.

"In stratigraphical geology," the lecturer went on to say, "the great divisions originally marked out by our predecessors stand,

but their number and the number of subdivisions have greatly increased. In 1822, when Phillips and Conybeare wrote their 'Geology of England and Wales,' twenty-three so-called formations were recognised, whereas now thirty-eight such are established, and these are divided into about 120 subdivisions, each characterised by some peculiarity of structure or of fauna. Palæontology as a separate science was not then known; structural and physical geology had chiefly occupied attention; but the study of organic remains has since advanced with such rapid and vigorous strides that the older branch was until lately in danger of being neglected and distanced.

"At that time the number of species of organic remains in Great Britain which had been described amounted only to 752, whereas now the number amounts to the large total of 13,276 species.

"Some idea of the extent and variety of the past life of our globe may be formed by comparing these figures with the numbers of plants and animals now living in Great Britain. Excluding those classes and families, such as the naked mollusca and others, which from their soft and gelatinous nature decay rapidly, and so escape fossilisation, and insects\*—the preservation of which is exceptional—the number of living species amounts to 3,989, against 13,183 extinct species of the same classes.

"Thus, while the total number of those classes of vertebrate and invertebrate animals and plants represented in a fossil state, and now living in Great Britain, is only 3,989, there formerly lived in the same area as many as 13,276 species, so that the fossil exceed the recent by 9,287 species. It must be remembered also that plants are badly represented, for, owing to their restricted preservation, the fossil species only number 823 against 1,820 recent species. Birds are still worse represented, as only eighteen fossil species occur against 354 recent species.

"But the multiplicity of British fossils, however surprising as a whole, has to be viewed in another and different light. The large total represents, not as the recent species do, the life of one period, but the sum of those of all the geological periods. Geological periods, as we construct them, are necessarily arbitrary. The whole geological series consists of subdivisions, each one of which is marked by a certain number of characteristic species, but each having a large proportion of species common to the subdivisions above and below it. These various subdivisions are again massed into groups or stages, having certain features and certain species peculiar to them and common throughout, and which groups are separated from the groups above and below by greater breaks in the continuity of life and of stratification than mark the lesser divisions. As these on the whole severally exhibit a distinct fauna and flora, we may conveniently consider them as periods, each having its own distinctive life, and the number of which in Great Britain we have taken approximately at thirty-eight.

"The number of species common to one period and another varies very greatly, but taking the average of the sixteen divisions of the Jurassic and Cretaceous series, of which the lists were, with a portion of those of the older series, given a few years since by Prof. Ramsay, † we may assume that about thirty per cent. of the organic remains pass from one stage to another.

"Dividing the 13,276 fossil species among the thirty-eight stages, or omitting the lower stages and some others, and taking only thirty, we thus get an average of 442 species for each; and, allowing in addition for the number common to every two periods, we obtain a mean of 630 species as the population of each of the thirty periods, against the 3,989 species of the present period. On this view the relative numbers are therefore reversed.

"This gives a ratio for the fauna or flora of a past to that of the present period of only as 1 : 6·3. But it must be remembered that probably the actual as well as the relative numbers of the several classes *inter se* in each and all of these several formations, varied greatly at the different geological periods. Still we have no reason to suppose but that during the greater part of them life of one form or another was as prolific, or nearly so, in the British area then as at the present day, and we may thus form some conception of how little relatively, though so much really, we have yet 'discovered,' and of how much yet remains to be done before we can re-establish the old lands and seas of each successive period, with their full and significant populations. This we cannot hope ever to succeed in accomplishing fully, for

decay has been too quick and the rock entombment too much out of our reach ever to yield up all the varieties of past life; but although the limits of the horizon may never be reached, the field may be vastly extended; each segment of that semicircle may yet be prolonged we know not how far; and it is in this extension—in the filling up of the blanks existing in the life of each particular period—that lies one great work of the future."

(To be continued.)

## NOTES

It is perhaps too much yet to expect any allusion to the interests of science in that very *staccato* composition, a Queen's Speech. The next best thing to this, however, occurred last Friday, when Lord Rayleigh, the seconder of the Address, very courageously pointed out the omission from the Speech of any allusion to an event "which had excited some public interest of a non-political character." His lordship referred to the recent Transit of Venus, in which the astronomers of this country had taken a part, but by no means, he thought, "too large a part." We confess that on this point we quite agree with Lord Rayleigh; indeed, we think he has stated the case, as against England in this matter, with remarkable mildness. But this is a mere detail compared with what followed. Lord Rayleigh said "he could not pass from astronomy without expressing a hope that other sciences of equal philosophical interest and greater material importance might receive more Government recognition than had hitherto been accorded them. It was something of an anomaly that England, whose great prosperity was largely due to scientific invention, should be slow to encourage those whose discoveries were laying the foundations of future progress. It was said, he knew, that these things might be safely left to individual enterprise, but there were fields of investigation in which individuals were powerless. We hope that this emphatic advocacy of the claims of science on Government, by one who has had the honour of being selected to second the Address on the Queen's Speech, augurs favourably for the amount of attention these claims are likely to secure during the forthcoming session.

THE words of Mr. Disraeli on Monday night with regard to University Reform are also very cheering to those who wish to see some decided action taken towards the thorough reform of our Universities. Mr. Disraeli's words were very strong, so strongly indeed as to amount to an assurance that Government really means to take into serious consideration this session the Report of the University Commission. "It is our opinion," the Prime Minister said, "that no Government can exist which for a moment maintains that the consideration of University Reform, and consequently legislation of some kind, will not form part of its duty." These words give out no uncertain sound. Mr. Disraeli said, moreover, that when the Report was presented at the end of last session, the Colleges were not assembled. It would be interesting to know whether the Colleges have yet met to consider the Report, and whether they are likely to act on this hint of the Premier and take some internal action—commence the work of reform from within, instead of waiting until they are driven to it by forces from without.

WE are able to give this week the first instalment of an abstract of Prof. Prestwich's lecture in the chair of Geology at Oxford. We have printed it in small type, in order to be able to give as much as possible of an address which, our readers will see, is likely to mark an important stage in the history of geological science. The address will shortly be published in a separate form.

THE Arctic Committee appointed by the Admiralty, having completed its work and sent in a final report, was dissolved last week. The Committee has got through much work in the way

\* The number of British species of insects amounts to between 10,000 and 11,000.

† Anniversary Addresses for 1863 and 1864. *Quarterly Journal Geological Society*. The tables were computed by Mr. Etheridge.

of ordering clothes and provisions, and making preparations of all kinds, in which it was ably assisted by Dr. Lyall and Mr. Lewis, two old Arctic officers of long experience. The further arrangements will be under the direct supervision of Capt. Nares, who will also assign the special duties to be undertaken by the different officers under his command. Commander Markham, who acquired much experience in ice navigation in 1873, will, it has now been arranged, accompany Capt. Nares in the first ship, and the younger executive officers are the very pick of the service. The medical staff, consisting of four officers, is also composed of men who are quite capable of taking charge of some branches of scientific investigation. One, at least, is a good botanist.

IN our last number, p. 268, is a letter in which the importance of attaching a competent geologist to the expedition is strongly urged. It is, of course, very desirable that, if scientific civilians are attached to the expedition, they should be men who can secure results which could not be equally well secured by any of the officers. As regards botany, the number of known flowering plants in Greenland is about 130, and it is unlikely that they can be largely added to. The point of botanical interest, within the unknown region, is the distribution of genera and species; and what is needed is diligent collection, with careful notes of the localities where the different species are found. This could be perfectly well done by the medical and other officers of the expedition. But to secure satisfactory geological results, a trained geologist, well acquainted with all the Arctic problems, is essential, and it is not likely that any of the officers would have the necessary qualifications. It is, therefore, very important that suggestions such as those of our correspondent last week, and of others who have urged the same views, should have their due weight.

AT the meeting of the Royal Geographical Society on Monday, Admiral Richards read to a large and distinguished audience, including H.R.H. the Prince of Wales, a paper on the proposed route to the Pole for the Arctic Expedition. It was intended at present, he said, that the two vessels should leave Portsmouth about the latter end of May, and, taking the usual route to Baffin's Bay, so endeavour to pass up Smith's Sound. In  $81^{\circ}$  or  $82^{\circ}$  north latitude they would probably separate, and while one would pass exploring the northern coast of Greenland, the other would push still further northwards. Everything, the Admiral was of opinion, had been done to ensure success. After a few remarks on the probable nature of the sea beyond  $82^{\circ}$  latitude, in the course of which he stated that from the violent current which swept southwards from Smith's Sound and through Hudson's Strait, along the coast of Labrador, he inferred that there was no great continent north of Smith's Sound, he concluded by pointing out the advantages that would result from the expedition.

WITH regard to the proposed German Arctic Expedition, the Committee of the Federal Council on Maritime Matters has proposed that the Council should submit the question of sending out a German Arctic Expedition to an Imperial Commission for consideration.

To those who are seeking for detailed information concerning the route of the Arctic Expedition, we would commend an article (with map) by Dr. R. Brown, in the *Geographical Magazine* for February, on Disco Bay, giving a very full idea, derived from personal experience, of the physical and social condition of the West Greenland coast between  $69^{\circ}$  and  $71^{\circ}$  N. lat. The *Magazine* states that Dr. Brown is "the greatest living authority on all scientific questions connected with Greenland." In the forthcoming volume of the "Transactions" of the Geological Society of Glasgow Dr. Brown will have a paper on the Noursoak Peninsula and Disco Island.

MANY influential French papers are circulating the intelligence that Lieutenant Bellot, although he came to London with the authorisation of the French Government, has not been admitted on the staff of the English Arctic Expedition. Strong remarks are made on the supposed selfishness of the British Admiralty.

LIEUT. CAMERON has sent home a map of Lake Tanganyika, from Ujiji to the south end, on a large scale; which represents geographical work of great importance. The work of Burton and Speke and Livingstone on the lake is confined to the portion north of Ujiji; for the voyage made by Dr. Livingstone along the west coast, south of Kasengé Island, was made at a time when he was too ill to make observations. Cameron's exploration is, therefore, a discovery in the true sense, and one of considerable interest, for that young officer has not only carefully delineated the outline of the lake, with all the indentations of the coast and the mouths of rivers, but he has discovered the outlet, and thus solved a great geographical problem. He is himself very cautious in assuming anything without personal inspection, and even yet hesitates to allow that the stream which he found flowing out, and traced for some miles, is really an outlet. He holds it to be possible that it may flow into some swamp or backwater. But there really seems to be little room for doubt on the subject, although Lieut. Cameron is wisely resolved to make a further examination. The river Lukuga flows out of the lake, at the end of a large bay, a short distance south of the Kasengé Island, between which and the outlet is the mouth of the Rogumba, which flows into the lake. The Lukuga, according to the Chief and people who live on its banks, flows from Lake Tanganyika to the river Lualaba. On May 4th Cameron went down the Lukuga for a distance of four miles, and found it to be three to five fathoms deep, and five to six hundred yards wide, but much choked with grass. There was a distinct, but not a rapid current flowing out. We understand Cameron's map of Lake Tanganyika will shortly be published by the Geographical Society.

A VERY interesting paper in the *Geographical Magazine* is on Great Thibet, being an account of a journey made in 1872-73 from the headquarters of the Indian Great Trigonometrical Survey by a semi-Thibetan, a young man trained to the work, named Major Montgomerie. He crossed the Brahmaputra to the north of Shigatze, and journeyed along the river Sheang Chu, to the lake Tengri-Nor (the local name, of which is Namcho), which he may be said to have discovered, as it has hitherto been placed on our maps merely on the authority of old Chinese surveys of unknown authorship. Its north point is just under  $31^{\circ}$  N. lat., and its south point about  $30\frac{1}{2}^{\circ}$ ; it lies between  $50^{\circ}$  and  $31^{\circ}$  west. It is about 50 miles in length and between 16 and 25 miles in breadth. After suffering considerable hardships the young explorer and his small party returned to Lhasa.

To the keepership of the Zoological collections of the British Museum, vacated by the resignation of Dr. J. E. Gray, Dr. Albert Günther has been appointed. The appointment of Assistant Keeper, rendered vacant by Dr. Günther's promotion, has been filled by the appointment of Mr. F. Smith, of the Entomological Department.

PROFS. CHERICI, Pigorini, and Strobel, have started a new periodical devoted to the prehistoric antiquities of Italy, under the title of the *Bullettino di Paleontologia Italiana*, the first number of which has just appeared. It is intended to issue monthly numbers, each of sixteen pages, with at least six illustrative plates in the course of the year. The present number contains articles on flint flakes worked to a rhomboidal form like some of those discovered in Kent's Cavern, on the mode of halting bronze celts, and notices of some recent discoveries in Italy. The annual subscription is seven francs.

We would remind our readers that Prof. Clerk-Maxwell's lecture to the Chemical Society, "On the dynamical evidence of the molecular constitution of bodies," will be delivered on Thursday next, the 18th instant. The Faraday Lecture will be delivered by Dr. A. W. Hofmann on the 18th of March.

The Cambridge Smith's Prizes have been adjudged as follows:—First prize, W. Burnside, B.A., Pembroke; second prize, G. Chrystal, B.A., St. Peter's. These two gentlemen were declared equal in the last Mathematical Tripos as Second Wrangler.

At the 300th anniversary of the founding of the University of Leyden, held on the 8th inst., degrees were conferred on the following English men of science:—Prof. Cayley, Mr. Huggins, Mr. Prescott Joule, Dr. Odling, and also Prof. Newcomb, of Washington, U.S., created Doctors of Mathematics and Physics. Mr. Charles Darwin was created Doctor of Medicine.

It is intended to issue, in October 1875, the first number of a periodical to be entitled *Mind*; a *Quarterly Review of Scientific Psychology and Philosophy*. Due prominence will be given in the Review to objective researches into the functions of the nervous system. All special lines of investigation affording insight into mind, in dependence on the main track of psychological inquiry, will receive attention in the Review; e.g., Language, Primitive Culture, Mental Pathology, and Comparative Psychology. *Mind* will be published by Messrs. Williams and Norgate.

The Board of Trinity College, Dublin, have elected Dr. J. Emerson Reynolds Professor of Chemistry in the University of Dublin. Dr. Reynolds is well known as an accomplished chemist, an excellent observer, and a skilful experimentalist. His researches on a new group of colloid bodies containing mercury, and on certain silicic acids, and his discovery of sulphuretted urea, have made his name well known. His election as one of the Professors of the Medical School of Dublin University is in every way for the interest of that school, and the announcement thereof will be received with the greatest favour by his colleagues.

THERE will be an examination at Downing College, on Tuesday, April 6, and three following days, for a Scholarship in Natural Science. Information can be obtained of the tutor of the College, Mr. John Perkins.

THE Government has received a despatch from Batavia, dated Feb. 3, announcing an eruption of the volcano Kloet, in the island of Java, whereby great destruction has been caused at Blitar.

We have received an instalment of the thirty-ninth supplement to Petermann's *Mittheilungen*, which is to be occupied with a full geographical and statistical account of the Argentine Republic, Chili, Paraguay, and Uruguay. The part to hand contains details concerning the physical features, political divisions, and population of the first-named, and a large finely executed map of all the four. Dr. Petermann himself compiles the strictly geographical account from the latest official statistics, while a geographico-statistical appendix is to be given by Dr. Burmeister, director of the Museum of Buenos Ayres.

The January part of Petermann's *Mittheilungen* contains a very interesting sketch, by E. Behm, of the origin and progress of the German African Society, which has already set to work in earnest on the West Coast, and promises to do much for the exploration of Africa in this direction. Dr. Petermann writes on the means by which the Society's explorers are to carry on their work, and strongly advocates the use of elephants. A map of the coast from 2° N. to 10° S. accompanies the papers, showing the routes of previous explorers, and those of Bastian, Güssfeldt, and Lenz,

in 1873-74. The moving spirit of the Society is the accomplished Dr. Bastian, who himself has travelled in nearly every region of the globe.

The January number of the *Bulletin* of the French Geographical Society contains the first instalment of a series of extracts from Abbé David's account of his travels in Mongolia in 1866. Abbé David is one of the most indefatigable of living travellers, and has probably done more than any other explorer to make known the natural history of China; for it is for botanical and zoological, rather than for geographical purposes, he travels. The narrative of this his first journey, and also of his second in 1868-70, up the Yang-tse-Kiang, and as far as the borders of Thibet, have been published in the *Nouvelles Archives* of the Paris Museum. From these narratives the present extracts, presenting mainly the geographical results, are taken. Abbé David was compelled to return to Europe last April to recruit his shattered health, and contemplates publishing a separate narrative of a third journey, from Peking down through the centre of China, during which he explored the important chain of the Tsingling Mountains.

At the last *soirée* of the Paris Observatory M. Dupuy de Lome explained his ferry-boat intended to carry railway trains between England and France. M. de Lesseps also delivered a lecture on the tunnel which it is proposed to bore from Calais to Dover. A commission of nineteen members has been elected by the Versailles Assembly to report upon the boring of a preliminary gallery. All the members are unanimous to grant the required authorisation. The president of the commissioners is M. Martel, one of the members for Pas de Calais. Four other members for that department are amongst the commission.

ON the 1st of February M. Leverrier announced to the Academy of Sciences the discovery, by M. Stéphan, the director of the Marseilles Observatory, of Encke's comet. On the 8th he announced the detection, by M. Stéphan, of Winnecke's comet, which is a more notable object, and can be observed with a finder. It is necessary to employ powerful instruments to see Encke's with certainty. Both comets were seen at Marseilles for the first time, that of Encke in 1818, and Winnecke in 1819.

IN the number of the 30th January of the *International Bulletin of the Paris Observatory*, M. Leverrier publishes the first list of the corrected observations for the small planets in 1873. Almost all the numbers are incorrect by a few tenths of a second, many of one second, some of twenty seconds, and one of two degrees.

THE Statistical Society have published this year for the first time an almanac for 1875. It is very neatly got up, and will no doubt prove useful to the members of the Society; and the very carefully and originally arranged calendar ought to make it interesting to outsiders. The almanac contains, besides, a list of the principal statistical documents issued by the several State departments, and a series of tables of equivalents of imperial and metric weights and measures. During the year 1875 the Council hope to make arrangements for compiling *Tables of Constants* relating to population, pauperism, crime, education, exports and imports, &c., with a view to their publication with the almanac for 1876.

THE following is the title of the essay to which the Howard Medal will be awarded by the Statistical Society in November 1875; the essays to be sent in on or before June 30, 1875:— "The State of the Dwellings of the Poor in the Rural Districts of England, with special regard to the Improvements that have taken place since the middle of the 18th century; and their Influence on the Health and Morals of the Inmates."

THE South Park Commissioners of Chicago have recently determined upon the establishment of botanical gardens in the



park, and have set apart for the purpose a tract of sixty acres, to which additions will be made from time to time as occasion may require. A botanical museum and herbarium will be included in the scheme. A circular has been issued by the board of managers, soliciting contributions from kindred institutions. The works are to be commenced as soon as the weather will permit.

It may be remembered that the United States steamer *Thetis*, after having completed the line of soundings made for the purpose of selecting a suitable route for a Transpacific cable, under Commander Belknap, again started on the same duty, under the charge of Capt. Erben, leaving San Francisco on the 1st of November direct for the Sandwich Islands. The *Hawaiian Gazette* of Dec. 2 announces her arrival at Honolulu, and remarks that, in all, sixty-two casts of the sounding-line were made, the first near the Farallones, the water gradually deepening from that point to 2,500 fathoms. In lat. 33° 10' and long. 132° the depth began rapidly to diminish, showing 1,417, 435, 413, and, finally, 385 fathoms in lat. 32° 58'. Numerous observations were made, which showed that there was a submarine peak rising about 2,200 fathoms from the ocean bed. Beyond this, for a circuit of five miles around this peak, deep water was found in every direction, and a few miles from the peak 2,500 fathoms were reached. From this the depth gradually increased, until in lat. 24° long. 152° the depth was 3,115 fathoms. This was only about 400 miles from Honolulu. The soundings brought up from the peak showed a mixture of lava and coral, which is supposed to be indicative of a submarine volcano. The temperature at the bottom was found to vary but little from 35° to 36° F. The results of the survey, according to the *Gazette*, are satisfactory, showing, if anything, a better line between Honolulu and San Francisco than that from San Diego.

The science of medicine and surgery according to European notions is making some progress in Japan. We learn that in the hospital at Hakodadi there are twenty young men regularly entered as students of medicine, daily lectures are given, and "bedside and other clinical demonstrations," the curriculum being similar to that of most medical schools. An illustrated medical journal in the Japanese language is also published every two months.

FROM the Superintendent's Report (1874) it appears that the Royal Botanic Gardens, Calcutta, are recovering very slowly from the devastating effects of the cyclones of 1864 and 1867. The growth of the shrubs and trees planted to replace those uprooted has not been very luxuriant, and a long time must elapse before the welcome and useful shade of noble trees such as once filled the garden will be enjoyed there again.

THE additions to the Zoological Society's Gardens during the past week include four Summer Ducks (*Aix sponsa*) from N. America, presented by Lord Braybrooke, F.Z.S.; a Macaque Monkey (*Macacus cynomolgus*) from India, presented by Mrs. Pole Shaw; a Zebu (*Bos indicus*) born in the Menagerie; a White-fronted Capuchin Monkey (*Cebus albifrons*) from S. America, deposited; two Indian Tree Ducks (*Dendrocygna arcuata*) from India, received in exchange; fourteen Basse (*Labrax lupus*), three Grey Mullet (*Mugil capito*), and a Cottus, (*Cottus bualis*) from British Seas, purchased.

### SCIENTIFIC SERIALS

*Der Zoologische Garten*.—In the December number the first article is one on monstrosities in wild birds, by Herr Pfarrer Jäckel, who describes several instances of additional and deficient limbs, and figures the leg of a Golden Eagle with two well-developed extra toes attached to the back of the tarsus.—The editor, Dr. Noll, treats of the salmon-fishery on the Rhine at

St. Goar. In 1873 the number of fish captured was 1,162, weighing in all 16,612 lbs.—An account by Dr. Taiber of the chase of the South American Ostrich (*Res americana*) with the *holas* is reproduced from the "La Plata Monatschrift."—Dr. R. Meyer describes two breeding nests of the squirrel (*Sciurus vulgaris*), in which the entrance was covered by a lid or flap, formed of fine grass; he confirms the statement that these animals have other nests to which they remove their young in case of danger.—Dr. A. Prætorius writes on the domestic animals of the ancient Greeks.—Victor Ritter von Tschusi-Schmidhofen states, on the authority of L. v. Hueber, that the Lesser Kestrel (*Tinnunculus cenchris*) is spreading northward in Carinthia, and replacing the common species (*T. alaudarius*), and also gives an instance of the breeding of the Waxwing (*Bombicilla garrula*) in Austria, a nest having been found in May 1872, in the Castle park at Kremser by Pfarrer Kaspar. Unfortunately, it was destroyed, and the birds disappeared.

*Journal of the Asiatic Society of Bengal*, Part II. No. 2, 1874.—Record of the Khairpur meteorite of Sept. 23, 1873, by H. B. Medlicott. This is simply a record of the appearance and fall of a meteorite, from the observations of several persons, and the weights of the specimens collected, the largest of which weighed 10 lb. 12 oz. 126 gr. The stone is described as being of the usual steel-grey colour and crypto-crystalline texture.—Contributions towards a knowledge of the Burmese Flora, Part I., by S. Kurz: an abridged enumeration of Burmese plants, phanerogamic and cryptogamic, as far as they have come to the writer's knowledge, containing the polyptaloid dicotyledons, Ranunculaceæ to the end of the Geraniaceæ. Epitomised generic descriptions are given, as well as a conspectus of the species of each genus.—On the Asiatic species of Moloss, by G. E. Dobson. Two new species are described, viz., *Nyctinomus traasatus* and *N. johorensis*.—Index to Part II. vol. xlii., 1873.

*Astronomische Nachrichten*, No. 2,018.—This number contains a long article detailing observations of the spectra of Winnecke's and Coggia's comets, and of changes in the head of that of Coggia. As to the spectrum of Winnecke's comet, the author states that on the 7th and 10th of May last the spectrum consisted of three bright bands, the middle one the brightest, and sharply limited towards the red end of the spectrum. The brightest portion of this band appeared a little more refrangible than the  $\delta_4$  line, while the beginning of the band coincided with it. The bright central portion of the comet,  $1\frac{1}{2}$  diameter, appeared to have in it certain bright points like stars of 12 to 14 magnitude, and the central portion gave a faint continuous spectrum. On the 6th of May, Coggia's comet gave a spectrum of three bands: the central one near  $\delta$  line was brightest, and the one nearest the blue the faintest; the nucleus and contiguous portions gave a continuous spectrum, in addition to the former one, extending from wavelength 590 to 440. On the 18th the middle line was seen sharply limited towards the red and shading towards the blue; the wavelength of the sharp limit was estimated at 515; the other bands were not so sharply defined on the red side as the central one, and the relative brightness of each is given as yellow, 2; green, 4; and blue, 1. The bands were strongest where crossed by the continuous spectrum of the nucleus. No other bands were visible; the positions of the commencement of the bands from a mean of observations are, 1st band, 562.5; 2nd band, 515.1; and 3rd band, 471.6. A change in the comparative brightness of the bands appears to have been noticed at times, and the author observes that one might expect absorption bands in the continuous spectrum corresponding to the bright bands, and that the changes of brightness of the lines should be viewed as an important matter in reference to this expectation. Traces of absorption bands appear to have been noticed, but their position not fixed. The following table of comparison of spectra of comets and hydrocarbons is given:—

	Comet. Coggia.	Comet. Henry. 1868.	Comet II. 1868.
First band	Beginning ... 562.5	562.6	563.1
of	Brightest part ... 553.8	559	—
Spectrum.	End ... 541	541	538
Second	Beginning ... 515.1	517.1	517.2
ditto.	Brightest part ... 511.8	516	—
	End ... 500	500	492
Third	Beginning ... 471.6	472.7	471.4
ditto.	Brightest part ... 468.9	466	—
	End ... 465	464	458

	Denzine.	Blue part of gas flame.	Blue part of petroleum flame.
Beginning of 1st band...	563 <sup>2</sup>	562 <sup>9</sup>	—
End ... ..	537	516 <sup>1</sup>	515 <sup>3</sup> bright line.
Beginning of 2nd band...	516 <sup>4</sup>	512 <sup>5</sup> broad bright line.	512 <sup>1</sup> faint band.
End of 2nd band ... ..	—	501	—
Beginning of 3rd band...	474 <sup>2</sup>	473 <sup>8</sup>	473 very delicate line.
Brightest part ... ..	—	471 <sup>2</sup>	472 <sup>5</sup> faint bands.
End ... ..	—	464	466 <sup>0</sup>
		436 <sup>8</sup> middle of a band.	437 <sup>1</sup> middle of broad faint band.
		430 <sup>9</sup> broad line.	430 <sup>8</sup> bright line.

From this table it appears that the beginning of the bands of each comet correspond, but that the brightest parts of these vary in position. For comparison with other comets the brightest parts of the bands are given:—

	Comet I., 1871.	Tuttle's Comet.	Encke's Comet.	Coggia's Comet.
1st band ... ..	557	557	555	554
2nd band ... ..	541	513	512	512
3rd band ... ..	—	472	473	469

The remainder of the paper on the change of form consists of daily notes referring to drawings and giving measurements of the comet. The nucleus appears to have changed its shape from round to oval and other forms.—In No. 2, 019 Dr. Luther gives an ephemeris for Planet (104) Clymene, which has not been seen since 1868.—Dr. Holoetschek and Dr. Luther give position observations of comets and minor planets made last year.—G. W. Hill sends a note on a long period of irregularity of Hestia, arising from the action of the earth, and its application to ascertain the value of the solar parallax.—J. Palisa writes to say that he has discovered Clymene; he also saw Dione and Althea again.—Winnecke mentions the discovery, by Borrelly, of a comet, position December 10th: Decl., + 39° 49' 5"; R.A., 16h. 4m. 65s.

## SOCIETIES AND ACADEMIES

### LONDON

Royal Society, Jan. 28.—“On the Theory of Ventilation: an attempt to establish a positive basis for the calculation of the amount of fresh air required for an inhabited air-space,” by Surgeon-Major F. de Chaumont, M.D., Assistant Professor of Hygiene, Army Medical School. Communicated by Prof. Parkes, M.D., F.R.S.

In a paper in the *Edinburgh Medical Journal* for May 1867, the author adduced some results to show that the evidence of the senses might be employed (if used with proper care and precautions) as the ground-work of a scale, and gave a short table of the amounts of respiratory impurity (estimated at CO<sub>2</sub>) which corresponded to certain conditions noted as affecting the sense of smell.

It is generally admitted that it is organic matter that is the poison in air rendered impure by the products of respiration. It is also admitted that it is the same substance that gives the disagreeable sensation described as “closeness” in an ill-ventilated air-space. Although the nature of the organic matter may vary to a certain extent, it will be allowed that a condition of good ventilation may be established if we dilute the air sufficiently with fresh air, so that the amount of organic matter shall not vary *sensibly* from that of the external air. Observations, however, as far as they have gone, seem to show that the amount of organic impurity bears a fairly regular proportion to the amount of carbonic acid evolved by the inhabitant in an air-space; and as the latter can be easily and certainly determined, we may take it as a *measure* of the condition of the air-space. If we adopt as our *standard* the point at which there is no sensible difference between the air of an inhabited space and the external air, and agree that this shall be determined by the effects on the sense of *smell*, our next step is to *ascertain* from experiment what is the average amount of CO<sub>2</sub> in such an air-space, from which we can then calculate the amount of air required to keep it at that condition. All the author's results have been obtained in barracks and hospitals.

The plan followed in all was to take the observations chiefly at night, when the rooms or wards were occupied, and when fires and lights (except the lamp or candle used for the observation) were out. On first entering the room from the outer air

the sensation was noted and recorded just as it occurred to the observer, such terms as “fresh,” “fair,” “not close,” “close,” “very close,” “extremely close,” &c. being employed. The air was then collected (generally in two jars or bottles, for controlling experiments), and set aside with lime-water for subsequent analysis, and the temperatures of the wet and dry bulb thermometers noted. About the same time samples of the external air were also taken, and the thermometers read. In this way any unintentional bias in the record of sensations was avoided, and this source of fallacy fairly well eliminated.

Although the records of sensation are various in terms, the author has thought that they might be advantageously reduced to *five* orders or classes, each of which he characterises by one or more appropriate terms in common use.

He then proceeds to give an analysis of the results of his observations on the case of each order, from which he draws the following conclusions:—

In order No. 1, “Fresh,” &c., a condition of atmosphere not *sensibly* different from the external air, the conditions which are those of *good* ventilation are the following:—

Temperature about 63° Fahrenheit.

Vapour shall not exceed 4.7 grains per cubic foot.

Carbonic acid shall not exceed the amount in the outer air by more than 0.2000 per 1000 volumes.

No. 2.—“Rather close,” &c. A condition of atmosphere in which the organic matter begins to be appreciated by the senses, and the ventilation ceases to be *good*:—

Vapour in the air exceeds 4.7 grains per cubic foot.

CO<sub>2</sub> in excess over outer air, ratio reaching 0.4000 per 1000 volumes.

No. 3.—“Close,” &c. The point at which the organic matter begins to be decidedly disagreeable to the senses, and the ventilation begins to be decidedly *bad*:—

Vapour reaches 4.9 grains per cubic foot.

Carbonic acid in excess over outer air to the amount of 0.6000 per 1000 volumes.

No. 4.—“Very close,” &c. The point at which the organic matter begins to be offensive and oppressive to the senses, and the ventilation *very bad*:—

Vapour reaches 5.000 grains per cubic foot.

Carbonic acid in excess over outer air reaches 0.8000 per 1000 volumes.

No. 5.—“Extremely close,” &c. The maximum point of differentiation by the senses:—

Vapour 5.100 grains per cubic foot.

Carbonic acid, in excess over the amount in the outer air beyond, 0.8500 per 1000 volumes.

It will at once be seen that the figures in No. 5 differ but little from those in No. 4, and that the probable *limit* of differentiation by the senses is reached in No. 4. The number of recorded observations in No. 5 is also very few comparatively; and the author thinks it would therefore be better to group the two together thus:—

Nos. 4 and 5 combined, being the probable limit of possible differentiation by the senses.

1. *Temperature*.—In the outer air 51° 43, in the inhabited air-spaces 65° 12, or a mean difference of 13° 69.

2. *Vapour and Humidity*.—The vapour in the outer air was 3.729, inside 5.108, or a mean difference of 1.379 grain, corresponding to a lowering of relative humidity of 8.92 per cent.

3. *Carbonic Acid*.—In the outer air 0.3928, in the inhabited air-spaces 1.2461, or a mean difference due to respiratory impurity of 0.8533, the range for probable error of result being between 0.8717 and 0.8349.

We may therefore say that when the vapour<sup>8</sup> reaches 5.100 grains per cubic foot, and the CO<sub>2</sub> in excess 0.8000 volume per 1,000, the maximum point of differentiation by the senses is reached.

The author then shows that there is a regular progression as we pass from one order to another.

He then proceeds to give a large number of tabular statements, calculations, and ratios, his practical conclusion being that the experimental data already quoted fairly justify the adoption of the following

*Conditions as the Standard of good Ventilation.*

Temperature (dry bulb) 63° to 65° Fahrenheit.

” (wet bulb) 58° to 61° ”

<sup>8</sup> It is to be understood that the amounts of vapour stated in these cases are in reference to a mean temperature of about 63° F.

Vapour ought not to exceed 4.7 grains per cubic foot at a temperature of 63° F., or 5.0 grains at a temperature of 65° F.

Humidity (per cent.) ought not to exceed 73 to 75.  
Carbonic Acid. Respiratory impurity ought not to exceed 0.0002 per foot, or 0.2000 per 1000 volumes.

Taking the mean external air ratio at 0.4000 per 1000, this would give a mean internal air ratio of 0.6000 per 1000 volumes.

Feb. 4.—Remarks on Professor Wyville Thomson's Preliminary Notes on the nature of the Sea-bottom procured by the soundings of H.M.S. *Challenger*, by William B. Carpenter, F.R.S.

The author began by referring to two of the questions started and partly discussed in Professor Wyville Thomson's communication.

The first of these questions is, whether the *Globigerina*, by the accumulation of whose shells the *Globigerina* ooze is being formed on the deep-sea bottom, live and multiply on that bottom, or pass their whole lives in the superjacent water (especially in its upper stratum), only subsiding to the bottom when dead.

Prof. Wyville Thomson has been led to adopt the latter opinion, by the results of Mr. Murray's explorations of the surface and sub-surface waters with the tow-net; while the close relation which they further indicate between the surface-fauna of any particular locality and the materials of the organic deposit at the bottom appears to Prof. Wyville Thomson to warrant the conclusion that the latter is altogether derived from the former.

The author, without calling in question the correctness of these observations, submitted, first, that they bear a different interpretation; and, second, that this interpretation is required by other facts, of which no account seems to have been taken by Prof. Wyville Thomson and his coadjutor. That the *Globigerina* live on the bottom only, is a position clearly no longer tenable; but that they live and multiply in the upper waters only, and only sink to the bottom after death, seems to the author a position no more tenable than the preceding; and he adduces the evidence which appears to him at present to justify the conclusion that whilst the *Globigerina* are pelagic in an earlier stage of their lives, frequenting the upper stratum of the ocean, they sink to the bottom whilst still living, in consequence of the increasing thickness of their calcareous shells, and not only continue to live on the seabed, but probably multiply there,—perhaps there exclusively.

That there is no *a priori* improbability in their doing so, is proved by the abundant evidence in the author's possession of the existence of foraminiferal life at abyssal depths obtained during the *Porcupine* expeditions of 1869 and 1870.

Of the existence of living *Globigerina* in great numbers in the stratum of water immediately above the bottom, at from 500 to 750 fathoms' depth, the author is able to speak with great positiveness. It several times happened, during the third cruise of the *Porcupine* in 1869, that the water brought up by the water bottle from immediately above the *Globigerina* ooze was quite turbid; and this turbidity was found (by filtration) to depend, not upon the suspension of amorphous particles diffused through the water, but upon the presence of multitudes of young *Globigerina*, which were retained upon the filter, the water passing through it quite clear. The contrast in size and condition between the floating shells and those lying on the bottom immediately beneath them was most complete.

The author then alluded to the observations of Dr. Wallich, with which his own are in entire accordance, and which leave no reasonable ground for doubt that the contrast is a consequence of their continued life. For it is clearly shown, by making thin transparent sections of the thick-shelled *Globigerina*, that the change of external aspect is due to the remarkable exogenous deposit which is formed, after the full growth of the *Globigerina* has been attained, upon the outside of the proper chamber-wall. This deposit is not only many times thicker than the original chamber-wall, but it often contains flask-shaped cavities opening from the exterior, and containing sarcode prolonged into it from the sarcodic investment of the shell. From these important observations, it seems to the author an almost inevitable inference that the subsidence of the *Globigerina* to the bottom is the consequence, not of their death, but of the increasing thickness and weight of their shells, produced by living action.

That the *Globigerina* which have subsided to the bottom continue to live there is further indicated by the condition of the sarcodic contents of their shells. In any sample of *Globigerina* ooze that the author has seen brought up by the dredge or the

sounding apparatus, part of the shells (presumably those of the surface-layer) were filled with a sarcode-body corresponding in condition with that of foraminifera known to live on the sea-bed, and retaining the characteristic form of the organism after the removal of the shell by dilute acid. In the same sample will be found shells distinguishable from the preceding by their dingy look and greyish colour, by the want of consistence and viscosity in their sarcode contents, and by the absence of any external sarcodic investment; these are presumably dead. Other shells, again, are entirely empty; and even when the surface stratum is formed of perfect *Globigerina*, the character of the deposit soon changes as it is traced downwards. (See "Depths of the Sea," p. 410). These facts seem to the author to mark very strongly the distinction between the living surface-layer and the dead sub-surface layer; and to show that there is nothing in the condition of the deep sea that is likely to prevent or even to retard the decomposition of the dead sarcodic bodies of *Globigerina*. There is a significant indication of the undecomposed condition of the sarcodic bodies of the *Globigerina* of the surface-layer, in the fact that they serve as food to various higher animals which live on the same bottom.

It seems to the author clear, from the foregoing facts, that the *onus probandi* rests on those who maintain that the *Globigerina* do not live on the bottom; and such proof is altogether wanting. The most cogent evidence in favour of that proposition would be furnished by the capture, floating in the upper waters, of any large thick-shelled specimens which are at present only known as having been brought up from the sea-bed. And the capture of such specimens would only prove that even in this condition the *Globigerina* can float; it would not show that they cannot also live on the bottom.

That the *Globigerina* not only live, but propagate, on the sea-bottom, is indicated by the presence (as already stated) of enormous multitudes of very young specimens in the water immediately overlying it. And thus all we at present know of the life-history of this most important type seems to lead to the conclusion, that whilst in the earlier stages of their existence they are inhabitants of the upper waters, they sink to the bottom on reaching adult age, in consequence of the increasing thickness of their shells, that they propagate there (whether by gemmation or sexual generation is not known), and that the young, rising to the surface, repeat the same history.

The author then proceeded to show that the relation between the surface-fauna and the bottom-deposit is by no means as constant as Prof. Wyville Thomson and Mr. Murray affirm it to be.

It may be taken as proved that there is no want of foraminiferal life in the Mediterranean. To confirm this the author referred to the results obtained by various observers. That Foraminifera, especially *Globigerina*, abound in its surface-water at Messina, is testified by Hæckel in the passage cited by Prof. Wyville Thomson; and when it is considered how large an influx of Atlantic water is constantly entering through the Strait of Gibraltar, and is being diffused through the Mediterranean basin, and how favourable is its temperature-condition, it can scarcely be doubted that if the doctrine now upheld by Prof. Wyville Thomson were correct, the deposit of *Globigerina* shells over the whole bottom-area ought to be as abundant as it is in the Atlantic under corresponding latitudes. Yet the author found the deeper bottoms, from 300 fathoms downwards, entirely destitute of *Globigerina* as of higher forms of animal life; and this was also the experience of Oscar Schmidt.

The author can see no other way of accounting for the absence of *Globigerina* ooze from the bottom of the Mediterranean, save on its shallow borders, than by attributing it to the unfavourable nature of the influences affecting the bottom-life of this basin; that is to say, the gradual settling down of the fine sedimentary deposit which forms the layer of inorganic mud everywhere spread over its deeper bottom; and the deficiency of oxygen and excess of carbonic acid which the author has shown to prevail in its abyssal waters, giving them the character of a stagnant pool; these influences acting either singly or in combination.

Another fact to which Prof. Wyville Thomson formerly attached considerable importance as indicative of the bottom-life of the *Globigerina*, is unnoticed in his recent communication, viz., the singular limitation of the *Globigerina* ooze to the "warm area" of the sea-bed between the North of Scotland and the Faroe Islands. Details of the observation will be found in the author's *Lightning* and *Porcupine* Reports on the exploration of this region. On the "cold area" the author never found a single *Globigerina*; the bottom consisting of sand and gravel, and the Foraminifera brought up from it being almost exclusively those

which form arenaceous tests. The "warm area," on the other hand, is covered with *Globigerina* ooze to an unknown depth; its surface stratum being composed of perfect shells filled with sarcode, whilst its deeper layers are amorphous. Near the junction of the two areas, but still within the thermal limit of the "warm," sand and *Globigerina* ooze are mingled; this being peculiarly noticeable on the "Hollena ground," which yielded a large proportion of our most noteworthy captures in this locality. Now, if the bottom-deposit is dependent on the life of the surface-stratum, why should there be this complete absence of *Globigerina* ooze over the "cold area," the condition of the surface-stratum being everywhere the same? The author can see no other way of accounting for it than by attributing it to the drift of the cold underflow carrying away the *Globigerina* that are subsiding through it, towards the deep basin of the Atlantic, into which he believes that underflow to discharge itself. Prof. Wyville Thomson, however, denies any sensible movement to this underflow, continuing to speak of it as "banked up" by the Gulf Stream,\* which here (according to him) has a depth of 700 fathoms; and this very striking example of want of conformity between the surface-fauna and the bottom-deposit consequently remains to be accounted for on his hypothesis.

The other of Prof. Wyville Thomson's principal conclusions relates to the origin of the "red clay," which he found covered large areas in the Atlantic, and met with also between Kerguelen's Land and Melbourne. Into this red clay he describes the *Globigerina* ooze as graduating through the "grey ooze;" and he affirms this transition to be essentially dependent on the depth of the bottom. And from the data which he gives he considers it an indubitable inference "that the red clay is essentially the insoluble residue, the ash, as it were, of the calcareous organisms which form the *Globigerina* ooze after the calcareous matter has been by some means removed." This inference he considers to have been confirmed by the analysis of several samples of *Globigerina* ooze, "always with the result that a small proportion of a red sediment remains, which possesses all the characters of the red clay." Prof. Wyville Thomson further suggests that the removal of the calcareous matter may be due to the presence of an excess of carbonic acid in the bottom waters, and to the derivation of this water in great part from circumpolar freshwater ice, so that, being comparatively free from carbonate of lime, its solvent power for that substance is greater than that of the superjacent waters of the ocean. He might have added probability to his hypothesis, if he had cited the observations of Mr. Sorby as to the increase of solvent power for carbonate of lime possessed by water under greatly augmented pressure.†

The author, however, after a careful examination of the data given by Prof. Wyville Thomson, thinks it is clear that no constant relation exists between depth and the nature of the bottom.

The author agrees with Prof. Wyville Thomson in thinking that the remarkable uniformity of the "red clay" deposit, coupled with its peculiar composition, indicates that it is not derived from the land; and the author's suggestion is based on its near relation in composition, notwithstanding its great difference in appearance, to *Glaucinite*—the mineral of which the greensands that occur in various geological formations are for the most part composed, and which is a silicate of peroxide of iron and alumina.

It is well known that Prof. Ehrenberg, in 1853,‡ drew attention to the fact that the grains of these green sands are for the most part, if not entirely, *internal casts* of Foraminifera; the sarcoid bodies of the animals having been replaced by glauconite, and the calcareous shells subsequently got rid of, either by abrasion, or by some solvent which does not attack their contents. It was soon afterwards shown by Prof. Bailey (U.S.), that in certain localities a like replacement is going on at the present time, the chambers of recent Foraminifera being occasionally found to be occupied by mineral deposit, which, when the shell has been dissolved away by dilute acid, presents a perfect internal cast of its cavities. The author then referred in this connection to the researches of Messrs. Parker and Rupert Jones on Mr. Beete Jukes's Australian dredgings, and to his own on a portion of the foraminiferal sand dredged by Capt. Spratt in the *Egean* (kindly placed in his hands by Mr. J. Gwyn Jeffreys).

The author said that alike in Mr. Jukes's and in Capt. Spratt's dredgings, some of these casts are in green silicates, and some in ochreous, corresponding precisely to the two kinds of fossil casts described by Prof. Ehrenberg.

The author, in the residue left after the decalcification of Capt. Spratt's dredgings, noticed a number of small particles of red clay, some of them presenting no definite shape, whilst others approximated sufficiently closely in form and size to the green and ochreous "internal casts" to induce him to surmise that these also had been originally deposited in the chambers of Foraminifera, their material being probably very nearly the same, although its state of aggregation is different. And if this was their real origin, he would be disposed to extend the same view to the red clay of the *Challenger* soundings.

In conclusion, the author submitted that if the red clay is (as he is disposed to believe) a derivation of the *Globigerina* ooze, its production is more probably due to a *post-mortem* deposit in the chambers of the Foraminifera than to the appropriation of its material by the living animals in the formation of their shells. That deposit may have had the character, in the first instance, of either the green or the ochreous silicate of alumina and iron, which constitutes the material of the internal casts; and may have been subsequently changed in its character by a metamorphic action analogous to that which changes felspar into clay. The presence of an excess of carbonic acid would have an important share in such a metamorphosis, and the same agency (especially when operating under great pressure) would be fully competent to effect the removal of the calcareous shells. This seems to the author the most probable mode of accounting for their disappearance from a deep-sea deposit, where no mechanical cause can be invoked. But in shallower waters, where the same excess of carbonic acid does not exist, and the aid of pressure is wanting, but where a movement of water over the bottom is produced by tides and currents, he is disposed rather to attribute the disappearance of the shells to mechanical abrasion. This is the explanation the author would be disposed to give of the disappearance of the shells from the green sand brought up by the *Challenger* in the course of the Agulhas Current; but whether it was mechanical abrasion or chemical solution that removed the foraminiferal shells whose internal casts formed the Greensand deposit of the Cretaceous epoch, must remain for the present an open question.

Linnean Society, Feb. 4.—Dr. G. J. Allman, F.R.S., president, in the chair.—Capt. Gilbert Mair and Dr. Llewellyn Powell were elected Fellows.—The following papers were read:—On *Arisana speciosum*, by Mr. J. Gammie. The remarkable appendage to the spadix of this plant had been supposed to be connected with a contrivance to favour cross-fertilisation, but the author had been unable to find that it is visited by insects.—On the Algae of Simon's Bay.—On the Fungi collected during the *Challenger* Expedition, by the Rev. M. J. Berkeley.—On the plants and insects of Kerguelen's Land, by Mr. H. N. Moseley. The author enumerated the insects met with during the visit of the party, including only one winged gnat, all the rest being apterous. A great quantity of one species were seen crawling over the *Pringlea*, but not on the inflorescence.—On the origin and prevailing systems of phyllotaxis, by the Rev. G. Henslow. In this elaborate paper the object of the author appeared to be to trace all existing systems of phyllotaxis to modifications of the decussate as the simplest.—A discussion followed, in which Mr. Hiern, Prof. Dyer, Mr. A. W. Bennett, and Dr. Masters took part.

Zoological Society, Feb. 2.—Dr. A. Günther, F.R.S., vice-president, in the chair.—Mr. Sclater exhibited and made remarks on a fine skin and skull of a female Huemul (*Cervus chilensis*), and a pair of horns of an adult male of the same animal, forwarded by Mr. Edwyn C. Reed, of the National Museum, Santiago, Chili.—Dr. E. Hamilton exhibited and made remarks on some deformed sterna of the common wolf.—Prof. A. H. Garrod read a paper on the kangaroo called *Halmaturus luctuosus* by D'Alberty, and on its affinities, in which such points in the anatomy of the type-species were described as served to explain its systematic position. It was shown from the form of the premolar and molar teeth, from the nature of the fur, and from other minor details, that this species must be placed in the same genus. It was also shown that *Dorcopsis brunni* (Müller), named more correctly *D. muelleri* (Schlegel). The species, therefore, should stand as *Dorcopsis luctuosus*, being the only other known species of the genus. It was also shown that *Dorcopsis*, together with *Dendro-*

\* See his "Depths of the Sea," p. 400.

† Proceedings of the Royal Society, 1862-63, p. 538.

‡ Ueber den Grünand und seine Erläuterung des organischen Lebens," in Abhandl. der Königl. Acad. der Wissenschaft. zu Berlin, 1855, p. 85.

*Iagus*, form a well-marked independent group of the Macropoid Marsupialia.—Mr. Slater read notices of some rare parrots now living in the Society's Gardens, and called special attention to examples of Goffin's Cockatoo (*Cacatua goffini*), and Bouquet's Parrot (*Chrysotis bouqueti*), as being amongst the rarest specimens.—A communication was read from Mr. Edward Bartlett, curator of the Museum and Public Library, Maidstone, containing a list of the mammals and birds collected by Mr. Waters in Madagascar, amongst which was a fine adult specimen of the Madagascar River-hog (*Potamocheilus edwardsi*).—A communication was read from Mr. E. P. Ramsay, containing remarks on the original skin of *Ptilonorhynchus rawnsleyi*, which he regarded as a hybrid between the Satin Bower-bird (*Ptilonorhynchus holocercus*) and the Regent-bird (*Sericulus chrysocephalus*).—Mr. R. Bowdler Sharpe read a paper entitled "Contributions to the Ornithology of Madagascar," being the fourth communication on the same subject made to the Society. This paper contained descriptions of a new Accipitrine form proposed to be called *Eutriorchis astur*, a new species of *Alcedo*, proposed to be called *A. croxylis*, and a new form of Nectariniidæ, to which the name *Noddypania coruscans* was assigned.—Dr. Günther, F.R.S., read a paper on some mammals recently collected by Mr. Crossley in Madagascar, amongst which were a new Lemur, proposed to be called *Chirogalenus trichotis*, and a new form of rodent, belonging to the Muridæ, for which the name *Brachytarsomys albicauda* was suggested.

Geological Society, Jan. 7.—Mr. John Evans, F.R.S., president, in the chair.—The following communications were read:—On the structure and age of Arthur's Seat, Edinburgh, by Mr. John W. Judd. The author said that Arthur's Seat, so long the battle-ground of rival theorists, furnished in the hands of Charles Maclaren a beautiful illustration of the identity between the agencies at work during past geological periods and those in operation at the present day. One portion, however, of Maclaren's masterly exposition of the structure of Arthur's Seat, that which requires a second period of eruption upon the same site, but subsequent to the deposition, the upheaval and the denudation of the whole of the Carboniferous rocks, is beset with the gravest difficulties. The Tertiary and Secondary epochs have in turn been proposed and abandoned as the period of this supposed second period of eruption; and it has more recently been placed, on very questionable grounds, in the Permian. The antecedent improbabilities of this hypothesis of a second period of eruption are so great, that it was abandoned by its author himself before his death. A careful study of the whole question by the aid of the light thrown upon it in comparing the structure of Arthur's Seat with that of many other volcanoes, new and old, shows the hypothesis to be alike untenable and unnecessary. The supposed proofs of a second period of eruption, drawn from the position of the central lava column, the nature and relations of the fragmentary materials in the upper and lower parts of the hill respectively, and the position of certain rocks in the Lion's Haunch, all break down on re-examination. While, on the other hand, an examination of Arthur's Seat, in connection with the contemporaneous volcanic rocks of Forfar, Fife, and the Lothians, shows that in the former we have the relics of a volcano which was at first submarine but gradually rose above the Carboniferous sea, and was the product of a single and almost continuous series of eruptions.—"The Glaciation of the Southern Part of the Lake-district, and the Glacial Origin of the Lake-basins of Cumberland and Westmoreland" (second paper), by Mr. J. Clifton Ward. The directions of ice-scratches in the various dales having been pointed out, the course of the several main glaciers was described, and it was shown how they must have become confluent in all the lower ground, forming a more or less continuous ice-sheet, which overlapped most of the minor ridges parting valley from valley, and was frequently forced diagonally across them. The positions of certain ice-grooves having an abnormal direction were described; in several cases these cross lofty ridges at right angles to their direction, and generally at passes or depressions along a water-shedding line. Most of those noticed had a generally east and west direction, and occurred at varying heights, from 1,250 to 2,400 feet. The author, while acknowledging the difficulty attendant upon any explanation, was inclined, though somewhat doubtfully, to regard these abnormal markings as due to floating ice, during the great period of interglacial submergence. The moraines were all believed to belong to the last set of glaciers. The subject of the "Glacial origin of Lake-basins" was then entered upon, and the following lakes discussed by means of diagrams drawn to scale, showing lake-depths,

mountain outlines, and the thickness of the ice.—Wastwater, Grasmere, Easdale, Windermere, Coniston, and Esthwaite, together with several mountain tarns. In the case of Wastwater, the bottom was shown to run below the level of the sea for a distance of a mile and a quarter, and the deepest point to be just opposite the spot at which the only side valley joins the main one. While the greatest depth of the lake is 251 feet, the thickness of the old glacier-ice must have been fully 1,500; and, all points considered, Prof. Ramsay's theory of glacial erosion seemed to the author certainly to be upheld. In like manner, the same theory was thought to account for the origin of the other lakes mentioned, such ones as Windermere and Coniston being but long narrow grooves formed at the bottom of pre-existing valleys. Mountain tarns were held to be due sometimes wholly to glacial erosion, sometimes to this combined with a moraine dam, and occasionally to the ponding back of water by moraines alone, or moraine-like mounds formed at the foot of snow-slopes.

Chemical Society, Feb. 4.—Prof. Odling, F.R.S., in the chair.—A communication from Mr. G. Whewell, entitled "Test for Carbolic Acid," and a note on the action of anhydrous ether on titanate tetrachloride, by Mr. P. P. Hanson, were read. Two crystalline compounds are obtained in this reaction: the one, boiling at 105° to 120° C., and melting at 42° to 48° C., has the composition  $TiCl_4(C_2H_5O)$ ; the other, titanium ethyl trichlorohydrate,  $TiCl_3(C_2H_5O)$ , melts at 76° to 78° C., and boils at 186° to 188° C.—The last paper was by Mr. W. H. Perkins, F.R.S., on dibromacetic and glyoxylic acids.

Institution of Civil Engineers, Feb. 2.—Mr. Thos. E. Harrison, president, in the chair.—The paper read was "On the origin of the Chesil Bank, and on the relation of the existing beaches to past geological changes, independent of the present coast action," by Prof. Joseph Prestwich, F.R.S., &c.—This remarkable bank of pebbles, extending from Portland to Abbotsbury, a distance of nearly eleven miles, was described with great accuracy by Sir John Coode, M. Inst. C.E., in 1853 (*vide* "Minutes of Proceedings Inst. C.E.," vol. xii, p. 520). It was then 43 feet high and 600 feet wide at the south end, decreasing to 23 feet high and 510 feet wide at the north end. The pebbles diminished in size from Portland to Abbotsbury. Sir John Coode also stated that the shingle consisted chiefly of pebbles of chalk-flint, with a small proportion of others of red sandstone, porphyry, and jasper, none of which could have been derived from local rocks. In order to determine their origin, he examined the coast from Portland to Start Point, and traced the flints to the chalk cliffs between Axmouth and Lyme, and the red sandstone, porphyry, and jasper pebbles to the new red sandstone of Budleigh Salterton and other places in Devonshire; whence he concluded that the only source from which the shingle of the Chesil Bank could have been derived was between Lyme Regis and Budleigh, and that it was propelled eastward along the coast to the Chesil Bank by the action of wind-waves, due to the prevalent and heaviest seas. The objection to this view urged at the time by the Astronomer Royal was, that the largest shingle occurred at the Portland end of the beach, or the most distant part from which it had travelled. More recently an old "raised beach," standing from twenty-one to forty-seven feet above the present beach, had been discovered on the Bill of Portland, and Prof. Prestwich showed that this beach contained all the materials found in the Chesil Bank, including also numerous chert pebbles from the Upper Greensand of the cliff between Bridport and Sidmouth. This raised beach was not due to any existing agency, but to causes in operation at a geological period so remote as the end of the glacial period, and before the land had assumed its present position and shape. Remnants of this beach could be found in or on the present cliffs, at intervals from Brighton to the coast of Cornwall, being more numerous in Devon and Cornwall, as the rocks were harder, than among the softer strata of Dorset and Hants, where, with few exceptions, the old line of cliff had been worn back and deeper bays formed. The travel of the shingle of this old beach was generally like that of the present beach, from west to east. The author considered that the action of the "Race" off Portland, and of the tidal waves during storms, combined to drive the shingle of the old beach at the Bill, and of that portion of it which must be spread on the Chesil Bank, whence the shingle was driven northward to Abbotsbury and Burton, by the action of the wind-waves, having their maximum force from the S.S.W., a direction which he showed to be the mean of the prevalent winds. Here these wind-waves became parallel with

the coast, and the westward movement ceased about Bridport, beyond which point the shingle travelled in the opposite direction, viz., from west to east, or from the coast of Devon to that of Dorset; the quartzite pebbles from the conglomerate beds of Budleigh Salterton, which travelled from that part of the coast eastward to and beyond Sidmouth, gradually diminishing in numbers as they approached Lyme, very few, if any, reaching Bridport. This conclusion was in accordance with the facts—(1) That the pebbles of the Devonshire and Dorset strata, which formed the shingle of the "raised beach," constituted also the bulk of the Chesil Bank; (2) That there were also, in that bank, pebbles of the rocks and slint of Portland itself; (3) That the largest pebbles occurred at the Portland end of the bank, the pebbles decreasing gradually in size to Abbotsbury. The large dimensions of the bank he attributed to the great accumulative and small lateral action of the waves. Prof. Prestwich next discussed the questions connected with the shingle of the south coast generally, and showed that the greater part of it was derived indirectly from beds of quaternary gravel and debris, from the wreck of the "raised beach," and partly from the strata of the chalk and other cliffs, and not altogether or directly from the present cliffs. He noticed, also, the westward movement of the shingle from Lulworth towards Weymouth, owing to the interference of the Isle of Portland with the force of the S.S.W. wind-waves, and considered that none of the Devon and West Dorset shingle beach now passed the Bill of Portland, and that other such breaks might exist to the eastward whenever similar conditions were repeated. He explained the origin of the Fleet, like that of the Weymouth backwater, and of the Lodmore Marshes, by the growth of the Chesil Bank on the one hand, and of the Ringstead and Weymouth Beach on the other, gradually damming in portions of the old coast line. Those beaches themselves travelled on a line along which the opposing forces of the wind-waves and tidal currents and the inertia of the mass to be moved were balanced. These views were stated to be in conformity with the theoretical opinion expressed on abstract grounds by the Astronomer Royal, and with the experience of practical persons residing on the spot. The paper was illustrated by sections and diagrams, showing the position and range of the "raised beach" along the coasts of Dorset and Devonshire.

**Royal Microscopical Society, February 3.**—Anniversary Meeting.—Mr. Charles Brooke, president, in the chair.—The Annual Report of the Council was submitted, and showed that the library, cabinet, and instruments were in a satisfactory condition; that seventeen new fellows, one honorary fellow, and one corresponding fellow had been elected during the year, and that ten had been removed by death.—The President read the annual address.—The result of the ballot for officers and Council for the ensuing year was as follows:—President, Mr. C. H. Sorby. Vice-Presidents: Dr. Robert Braithwaite, Mr. Chas. Brooke, Dr. J. Millar, and Dr. W. B. Carpenter. Treasurer, Mr. John W. Stephenson. Hon. Secs., Messrs. H. J. Slack and Charles Stewart. Council: Messrs. Frank Crisp, J. E. Inkpen, S. J. McIntire, Henry Lee, W. T. Loy, Dr. Lawson, Dr. J. Matthews, Messrs. George Shadbolt, Chas. Tyler, F. H. Ward, F. H. Wenham, and Chas. F. White. Assist. Sec., Walter W. Reeves.

PARIS

**Academy of Sciences, Feb. 1.**—M. M. Frémy in the chair.—The following papers were read:—On the physico-chemical forces and their intervention in the production of natural phenomena, by M. Becquerel.—A note by M. Yvon Villarceau, relating to the discussion of the observations of the transit of Venus.—M. Leverrier then presented to the Academy a new part of the "Atlas elliptique de l'Observatoire de Paris." This atlas represents a circular zone of 5 degrees breadth (2½ each side of the ecliptic), and on each map contains a space of 20 min. of R. A. Seventy-two maps will thus complete it, but it will doubtless contain several more for the vicinity of the equinoxes; all stars visible in a telescope of 24 centimetres aperture (about 9½ in.), down to the 13th magnitude inclusive, will be carefully mapped in it. Four plates of the new part just published are by MM. Paul and Prosper Henry, and contain 7,655 stars.—M. Leverrier then made some remarks on the results of the observations of the transit of Venus.—The Academy elected as candidates for the chair of Natural History of Inorganic Bodies, at the Collège de France, rendered vacant by the death of M. Elie de Beaumont, in the first place, M. Ch. St. Claire-Deville, and in the second, M. Fouqué.—

The remaining papers read were the following:—On an "anallatic" telescope and its application to a levelling compass and a "tachéomètre," by M. C. M. Goulier.—On the general theory of percussions and the manner to apply it in the calculation of the effect of shots, and the different parts of the gun-carriages, by M. H. Putz.—A note on magnetism, by M. J. M. Galignan. Another one on the same subject, by M. A. Tréve.—On the magnetic anomaly of peroxide of iron prepared from meteoric iron, by M. L. Smith.—On the artificial reproduction of monazite and xenotime, by M. F. Radominski; these minerals are the very rare phosphates of cerium, lanthanum, and didymium.—On the pulverisation of manures and the best means to increase the fertility of soils, by M. Menier.—A note by M. H. Tarry, on the possibility of predicting for some days in advance the arrival in Europe of cyclones, which cross the Atlantic; these remarks were based on the fact that M. Tarry received telegrams on Jan. 11th from Boston and St. Pierre Miquelon, stating that a great cyclone had its centre in Newfoundland on Jan. 10th, and was taking its course eastward—that it was calculated to arrive in Europe by way of Ireland in four or five days. The cyclone actually reached Ireland on Jan. 15th, and progressed in an easterly direction for several days after.—MM. J. B. Schnezler, Rohart, and Le Breton made some communications on Phylloxera.—On "viridic" acid, by M. C. O. Cech.—On a case of recovery from aneurism of the right external carotid artery through digital pressure, by M. J. A. Marques.—On the analysis and classification of cements, by M. Dourcournau.—A note by M. Bonnet, on aerial locomotion.—A memoir by M. Maillard, on the treatment of cholera.—M. Gruy communicated the provisional elements of Comet VI., 1874, Borrelly.—M. Stéphan transmitted an account of new observations of the comets of Encke and Winnecke.—M. Genocchi made some observations regarding M. Darboux' paper on the existence of the integral in equations with partial derivatives, containing any number of functions and independent variables.—M. Darboux made a communication on the same subject.—On hydrogenated iron, by M. L. Cailletet; account of experiments made by the author, showing that iron will absorb on the average 240 times its own volume of hydrogen, but after heating will not again absorb hydrogen, as Graham showed to be the case with palladium; the experiments gave results in accordance with those obtained by St. Claire-Deville, Troost, and Hautefeuille, in their researches on the passage of hydrogen through homogeneous bodies, and the compounds of hydrogen with alkaline metals.—On the molecular equilibrium of a solution of chrome alum, by M. Lecoq de Boisbaudran.—On perbromide of bromo-acetylene, by M. E. Bourgoïn.—On the improvements in the quality of beetroot, by M. Ch. Violette.—On a special butyric fermentation, by M. P. Schützenberger.—On the dilating action exercised by the glosso-pharyngian nerve on the vessels of the mucous membrane at the base of the tongue, by M. A. Vulpian.—On a new historical document relating to Salomon de Caus, by M. G. Depping.—A note by M. Neyreneuf, on the combustion of explosive mixtures.—A note by M. J. Kordon, on the composition and distribution of printing type.

CONTENTS

	PAGE
HANCOCK'S "BIRDS OF NORTHUMBERLAND AND DURHAM" . . . . .	281
OUR BOOK SHELF:—	
Moore's "Physiological Chemistry" . . . . .	283
Carpenter's "Microscope" . . . . .	284
Mathematical Works by Dr. Weyr . . . . .	285
Dr. Just's "Botanic Year-Book" . . . . .	284
LETTERS TO THE EDITOR:—	
Sub-Weldan Exploration.—W. Topley . . . . .	284
Gaussian Constants.—COUNT O. FEICHBENBACH . . . . .	285
Columnar Formation in Mud Banks.—Dr. J. W. BLACK . . . . .	285
Flowers and Bees . . . . .	285
Iron Pyrites . . . . .	285
The Micrographic Dictionary.—Pollen Grains.—W. G. SMITH . . . . .	286
The Phylloxera.—G. H. WOLLASTON . . . . .	286
THERMOELECTRIC SCALES.—THOMAS SOUTHWELL . . . . .	286
OUR ASTRONOMICAL COLUMN:—	
The next return of Halley's Comet . . . . .	286
Encke's Comet . . . . .	287
Aurares . . . . .	287
Lalande's "Étoile Saggière" . . . . .	287
NEWS FROM THE "CHALLENGER." By Prof. WYVILLE THOMSON, F.R.S. . . . .	287
THE MOAS OF NEW ZEALAND (With Illustration) . . . . .	289
THE RECENT STORMS IN THE ATLANTIC. By W. DE FONVILLE . . . . .	290
THE PAST AND FUTURE WORK OF GEOLOGY. By Prof. PRETITCH, F.R.S. . . . .	290
NOTES . . . . .	292
SCIENTIFIC SERIALS . . . . .	293
SOCIETIES AND ACADEMIES . . . . .	295

THURSDAY, FEBRUARY 18, 1875

## THE LOAN COLLECTION OF SCIENTIFIC INSTRUMENTS

WE do not think we are going too far in assuming that the unusually influential meeting held at South Kensington last Saturday may be regarded as the first and a very emphatic step in a most important work. What the nature of that meeting was will be seen from the following report, which has appeared in most of the daily papers:—

"A meeting was held at South Kensington on Saturday for the purpose of discussing the advisability of bringing together a loan collection of scientific apparatus. The Duke of Richmond, the Lord President of the Council, took the chair, the Vice-President, Lord Sandon, being also present. The following noblemen and gentlemen attended the meeting:—Lord Hampton, President of the Institute of Naval Architects; Prof. Abel, Chemist to the War Department; Dr. Allan, President of the Linnean Society; Mr. W. B. Bascomb; Prof. F. A. Bradley; Mr. F. J. Bramwell, President of the Institution of Mechanical Engineers; Mr. H. Cole, C.B.; Admiral Collinson, C.B.; Mr. G. Dixon, M.P.; Prof. W. T. Thiselton Dyer; Prof. G. Carey Forster; Prof. E. Frankland; Dr. Gladstone, President of the Physical Society; Prof. Goodeve; Mr. T. E. Harrison, President of the Institution of Civil Engineers; Dr. Hooker, C.B., President of the Royal Society; Prof. T. H. Huxley, Secretary of the Royal Society; Mr. J. Norman Lockyer; Mr. C. W. Merrifield; Prof. Odling, President of the Chemical Society; Prof. Ramsay; Major-General Sir H. Rawlinson, K.C.B., President of the Royal Geographical Society; Dr. Burdon-Sanderson, Vice-President of the Royal Society; Mr. T. Savage; Sir J. P. Kay-Shuttleworth, Bart.; Mr. C. W. Siemens; Mr. Warrington Smyth; Rev. J. Twisden; Prof. Tyndall, President of the British Association; Prof. W. C. Unwin; Sir J. Whitworth, Bart.; and Dr. J. Woolley. On the motion of the President of the Royal Society, it was unanimously agreed that such an exhibition would be most instructive and valuable. The question of the limits of the collection was discussed, and sub-committees were appointed to deal with the various branches of science to which it is proposed the collections should have reference. It was generally understood that the main objects of the exhibition would be to show modern apparatus for teaching and for research; the applications of science to industry; and such apparatus as is historically interesting from the occasions in which, or the persons by whom, it had been employed. The exhibition will be opened at the commencement of June. It is, however, doubtful at present whether all branches of science will be taken during this year, or whether the exhibition will be extended over two years, as the space disposable in the South Kensington Museum, where the exhibition is to be held, is rather restricted."

The presence at a meeting of this kind of two such influential members of her Majesty's Government as the Duke of Richmond and Lord Sandon may, we think, be taken as significant that the present Government is willing to do what it can for the advancement of science and of scientific education, and in order to do this, is seeking to learn what its duties are in the matter. The tone of the reply of the two above-named Ministers to the King's College deputation last week is quite in accordance with this view.

The meeting was altogether a remarkable one, consisting as it did of two of her Majesty's Ministers, together with many of the most eminent men of science in the country; and their unanimity in favour of the proposal is a proof of its high importance, and we hope a guarantee of its success.

With regard to the proposal itself, the wonder is that no steps have long ere now been taken to organise a Museum for the illustration of the Physical, Chemical, and Mechanical Sciences. One of the recommendations contained in the Fourth Report of the Commission on Scientific Instruction and the Advancement of Science proposes the formation of a collection of physical and mechanical instruments, and submits for consideration whether it may not be expedient that this collection, the collection of the Patent Museum, and that of the Scientific and Educational Department of the South Kensington Museum, should be united and placed under the authority of a Minister of State. In our article on this Report (*NATURE*, vol. ix. p. 397) we went so fully into the subject that it is unnecessary to dwell again upon it now. Why the particular departments mentioned above should be left out in the cold it would be difficult to give a reason for; probably, as we before suggested, it has been simply from want of thought; and now that so many eminent men of science have met together, under the auspices of two members of her Majesty's Government, we may hope that the great gaps in our system of Museums will not remain long unfilled up. Natural History, including Geology, Zoology, Botany, not to mention nearly every practical application of science, such as Mining, &c., have, in London at least, resources for the practical study of their history and methods; and we are exceedingly glad that this is the case. Greatly on this account, we believe, is it that these sciences are so popular, and that so much more is known about their results among the people at large, than about the various departments of the Physical Sciences. If a student in any of the above sciences wants to pursue an investigation on any point connected with their history, their methods, or their results, he has magnificent scope for so doing both in London and in other large towns throughout the country. But the unfortunate student of any department of the Physical Sciences—Electricity, Magnetism, Heat, Light, Chemistry—if he wants to study thoroughly or to investigate any point connected with his subject, has nothing for it but to buy his apparatus, borrow it from a friend, or perhaps only look at it in a shop window.

A collection which exemplifies the history of the progress of any science may be made both interesting and instructive; and of all the sciences none can be more aptly and fully illustrated in this respect than the Physical Sciences. How interesting even to the uninitiated was the recent exhibition of a historical series of musical instruments at South Kensington; but how much greater would be the interest that would attach to, and how much higher the instruction to be derived from, a collection of apparatus that would exhibit the progress in the single department of Optics, say from Newton down to Cornu and Fizeau, embracing as it might very well do all the work that has been done in recent years by means of the prism. So in the department of Heat in all its branches,



how intensely interesting and instructive a collection might be made. The mere mention of other subjects—Electricity, Magnetism, Acoustics, &c.—suggests possibilities of magnificent collections which might be formed, if only the public spirit of fortunate possessors could be properly roused; and on this latter point there need, we think, be no fear.

One condition, we think, ought to be insisted on: the collection which it is proposed to form should be almost entirely confined to the region of scientific research and instruction, and should include as little as possible of the practical applications of science, which, indeed, have hitherto had almost wholly their own way in our exhibitions and museums. It should be distinctly understood and acted upon, that the collection which it is hoped will be opened at South Kensington in a few months is meant to illustrate the history and methods of abstract scientific research, of the true nature of which the public know really nothing, and of teaching. Our friends the engineers and other practical men, we are sure, will see the fairness of our demand, and they are so powerful, and have hitherto been so largely represented, that they can well afford to be generous in this matter.

While one great value of the collection about to be formed will no doubt be from a historical point of view, it cannot but serve also an important educational purpose. It will let the public see how multifarious are the ways of science, will show them that it is no mere child's play, and tend to impress them more and more with the great importance of scientific education as a means of culture and mental training. When the claims of scientific research upon Government are advocated, those who are familiar with such a collection will know what is spoken of, and for what purpose the public money is wanted.

We hope, and indeed believe, that the experiment about to be tried at South Kensington is simply the first step towards something more permanent and much more extensive—in short, the fulfilment of the second part of the recommendation of the Commission quoted above. We believe that if such a collection is once formed, if it be properly organised and arranged and made perfectly intelligible to the public, both as to its theoretical principles and practical bearings, it will in time lead to a scheme as comprehensive, as complete, and as invaluable as the French Conservatoire des Arts et Métiers, to which we have frequently referred as a model which our Government would do well to copy. The unsatisfactory state of our Museums, their want of system, and incompleteness, we have often insisted upon. We think we are now on the road towards mending this latter defect; other defects can only be remedied by the adoption of the Commission's recommendation, to unite the principal collections under one responsible Minister of State. It would without doubt be greatly to the advantage both of the science and the industry of the country to have collected and arranged in one establishment, supported by Government, all the apparatus and illustrations of all the processes connected with every department of science, pure and applied, abstract and practical, instead of the heterogeneous and imperfect collections at present scattered in various buildings under different systems of management.

### CAVE HUNTING

*Cave Hunting.* Researches on the Evidence of Caves respecting the Early Inhabitants of Europe. By W. Boyd Dawkins, M.A., F.R.S., &c. (London: Macmillan and Co., 1874.)

NO wonder that timid wanderers, peering into the dark mysterious depths of some abyss, should in their awe have peeped them with gnomes and goblins, or fancied themselves at the portals of another world. Well might poetic fancy, stirred by the thousand flashes thrown back from the spar-spangled walls of some vast cave, have called up fairy forms to give life to the beautiful stillness of the scene. Less weird and less poetic, but not less interesting, are the associations gathered by history and tradition around caves. We hear of rude tribes who habitually lived in rocky fastnesses occupying the caves for shelter and protection; and even when these were not used as permanent dwellings, we learn that in troublous times many a clan, family, or individual have had to leave their comfortable homes and betake themselves to the caves and holes of the rocks. We might well expect, therefore, that in the earliest age, when uncultured man fought for the richest hunting-ground, or struggled with nature for bare subsistence, the caves and rock-shelters should often have been his home.

We read again of the Patriarch purchasing the Cave of Machpelah as a burying-place for his family. Are we to suppose that this was a custom then newly introduced, or ask whether it was not probable that the associations of thought likely to spring up in the social life of the simple pastoral tribes of primæval man would not soon teach him to bury his dead out of his sight instead of casting them out to be devoured by wild beasts, and that he should then choose the tombs offered by nature and bury in caves? On searching for evidence on this point, we soon find that from almost the earliest time of which we can learn anything with respect to the human race, men lived and died in caves, and a later people of somewhat different habits buried in them; what the earlier race did with their dead is not quite clear.

Deposits in caves are generally more or less protected from the destroying agents which attack outside superficial deposits, and so we have in them a vast store of odds and ends, dropped, thrown away, or buried, which enable us to form a fair idea of the habits of the life of man long before the period to which history or tradition can reach back, and also of other creatures which lived with him or haunted the neighbourhood in those ancient times.

Caves are of all ages, and are formed in many ways. There are bone-bearing fissures of Rhetic age. The phosphate beds of Caylus, full of bones of mammals, from early Tertiary to recent, are only ancient swallow-holes and caves. But the cave deposits we have to consider now are all post-tertiary, and are due almost entirely in the first instance to the decomposition of limestone rocks by the action of acidulated water. Mechanical action comes in afterwards and enlarges and finishes the work. There is, however, a difficulty as to how this action goes on in some sheltered places which rain cannot reach and where no water appears to run, such as many of the rock-shelters or abris. A probable explanation in some

cases is that a warm moist wind blows against a rock of lower temperature, and the vapour is condensed all over the surface. Minute vegetation at first, conspicuous mosses and lichens afterwards help the work, and the softer portions of the cliff melt away—here on a small scale, so as to leave marks somewhat like pholas borings; there on a large scale, leaving an overhanging sheltering ledge, such as may be seen in the sketch (Fig. 71, p. 249). Acidulated water, passing through cracks and fissures in the limestone rock, eats away the sides and enlarges its channel; but when it gets to the open air and is aerated in waterfalls or draughts, it gives off as gas the acid which helped it to hold the carbonate of lime in solution, and down this goes as stalagmite, or in some other form. Here we have a measure of time, as we can observe the present rate of accumulation, but we cannot get at any satisfactory results because the agents producing change are so many, so various, and so irregular in their action. It is not only, as Prof. Dawkins points out in the case of the Jockey Cap in Ingleborough Cave, that “it may be the result not of the continuous but of the intermittent drop of the water containing carbonate of lime” (p. 40), but the water continually stops up with stalagmitic accumulations the hole or crack through which it came; and so in many parts of that very cave we see a dry roof cross-barred with ridges representing joints, which once let water trickle through, but which are now sealed up with travertine.

Prof. Dawkins points out other sources of error in calculations based on the rate of accumulation of stalagmite.

But we have the order of succession of deposits containing various relics, and, where there is no reason for suspecting subsequent disturbance, the order is always the same. We have the identification of the style of instruments used by man, the groups of animals that lived at the different periods, with those of other deposits, the antiquity of which is measured by geographical changes. So, putting all the evidence together, we get a connected story.

Prof. Dawkins begins with the newer, and gives an account of how the civilised Celtic people were, after the Romans left, driven away to the west by the heathen Saxon—*y Saeson digred*, as they were called by the Welsh—and how they often had to betake themselves to the caves and holes of the rocks for shelter from their foes. Their remains have been found in the Victoria Cave at Settle, and the Kirkhead Cave on Morecambe Bay. Both of these are on the borders of the Cumbrian Mountains, to which the Celtic people were being pushed from the rich lowlands of Yorkshire and Lancashire, as, further south, they were driven into the mountains of Wales. Prof. Dawkins gives an interesting sketch of the history of this period; and, in commenting on the value of certain animals for purposes of classification, tells us when many of our pets and other animals were first introduced, and when many animals, once wild in our country were exterminated. Though there is evidence that the dog had for ages been the companion of man, the cat seems to have been unknown before about the year 800 A.D. The common fowl and fallow deer seem to have been introduced by the Romans. The reindeer and beaver were wild in Britain after the Norman Conquest; the wild boar till

the time of James I., and the wolf till long after the Civil War. These cave-folk were not prominent in history, but as their relics refer them to a time when events which are chronicled in history were happening in our country, Prof. Dawkins has described them under the head “Historic Period.”

But the caves have yielded also the records of long ages before that; the iron, bronze, and polished stone ages. Of this period there is no contemporaneous history in Western Europe; but who knows how much of Egyptian, Assyrian, or Chinese history may tell of events synchronous with neolithic man in Europe? This period does not appear to have been cut off from historic times by any great physical changes, and, as we shall see by and by, the Britons of to-day seem to be in part descended from the ancient race that dwelt here in prehistoric times. They were a wide-spread pastoral people, sometimes dwelling in villages of huts on land, sometimes in wooden clay-patched houses standing on piles far out into a lake. They had domestic animals, and cultivated fruits and corn. As time went on, they acquired the use of bronze, then iron, and as they lapped round the outskirts of oriental civilisation, and its influence spread, some were absorbed and some driven back to the mountains. Who, then, were these people who lived just before our historic times? Is any part of the population of modern Europe directly descended from them, or were they all exterminated and their place taken by the invading wave of population? Prof. Huxley has pointed out the twofold type that may be found in some peoples that have for centuries been looked upon as one race. Cæsar, he reminds us, found two types of Celts in this country, the fair and the swarthy. In England of to-day we find, speaking English and calling themselves Englishmen, the same two types, the Xanthochroid and the Melanochroid. Huxley further points out that throughout the south-west of Ireland, South Wales, west and south-west of France, Spain, Italy, Greece, &c., the dark characters prevail, while anyone travelling from North Ireland across Scotland, Flanders, Germany, &c., would see none but fair people all the way. He thinks the dark complexions may have been inherited from Iberian ancestors, whose more direct representatives we have in the Basques. The fair-haired invaders did not exterminate, but absorbed or united with a great conquered population of dark-skinned people; and these two races, each we must suppose of great “prepotency of transmission,” have handed down their distinctive characters for centuries; sometimes one, sometimes the other predominating. We must therefore bear in mind that the people included under the term “neolithic” in no way form one ethnological group. Neolithic is a useful temporary term to represent a phase of culture which different races reach and pass, and to which a different relative position in time must be assigned in different parts of the world. New forms, new metals, or new languages, may have come in with invading tribes and have been adopted by the now mixed race; but there is no evidence of an entire sweeping away of the older fashions at any period from neolithic times to our own.

But long before those times also we have abundant records of man’s sojourn in Western Europe. Who and of what race were these earlier or palæolithic folk? Their

state of civilisation and habits of life, inferred from their remains, point to the dwellers along the Arctic shores, and especially to the Eskimo, as their nearest representatives. Who the Eskimo are is not known, but a broad-skulled race seems to be following them from the east as the broad-skulled race of later neolithic times did the long-skulled people of the earlier neolithic age, who were separated from them by differences of racial character quite as strong as any we have in the present state of the evidence any right to assume existed between the neolithic dolicocephali and the palæolithic people.

Prof. Dawkins finds osteological affinities between the Basques and the earlier neolithic Troglodytes, and Mr. John Rhys follows this up by pointing out peculiarities of construction in the Welsh language which he thinks may

be explained by the idioms having been derived from an Iberian tongue. It seems agreed that we have in the neolithic people a mixture of an Aryan and Turanian race. May it not be that the Basques are the direct descendants of a palæolithic tribe who were not quite absorbed, but who have gone through a neolithic phase of culture, and that the Eskimos may, when we know them, turn out to be another palæolithic tribe banished by the Aryan invaders to the far north, and living still in the same rude way that they did in palæolithic times?

However, this is at present mere speculation; the data before us do not furnish sufficient evidence to enable us to come to any satisfactory conclusion on this point.

There have been no great geographical changes since neolithic times. The hand of man has done perhaps

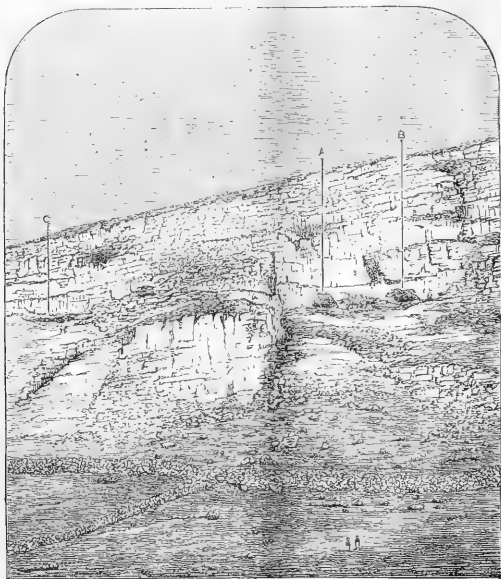

View of King's Scar, Settle, showing the entrances of the Victoria and Albert Caves (from a photograph). A, B, Victoria; c, Albert.

more than nature towards modifying the climate of Western Europe since that period. The surface of the country was then "covered with rock, forest, and morass, which afforded shelter to the elk, bison, and urus" (p. 262). When man had felled the woods and drained the land, the country must have become perceptibly dryer and warmer.

But, in tracing back the history of man, we meet with a great difficulty at the close of the early stone or palæolithic period. There is generally a gap. We ask, Why did not the use of polished weapons come in gradually, so that we might find a few polished weapons at first, then more as we search the deposits of more recent date; just as bronze and iron were gradually introduced among the stone-using people, but did not at once supersede the use of that material? Why, in the deposits along rivers and in

caves, is there so often evidence of a great lapse of time between their occupation by the palæolithic and neolithic folk? Why is the group of associated animals so different? Why is it that, where deposits belonging to these two periods have been found together, there is generally evidence to show that they were separated in age by an enormous interval, during which considerable geographical changes have been brought about by the gradual operations of nature? This has induced many to seek for some cause of a general kind to explain the sweeping away of the old order of things, and the incoming of a new and different group. Of course geologists seek first an explanation in the glacial period. But wherever the deposits containing the remains of palæolithic man have been found in connection with boulder-clay, and their relation can be made out, the implement-bearing beds are

found resting on the drift in a manner that shows that they were laid there long after the deposition and even subaërial erosion of the glacial deposits.

In one cave on the borders of the Lake Mountains it was, and is still, hoped we may find out something more definite about the relation of the palæolithic to the glacial period.

In the absence of direct evidence, such as the overlap of boulder-clay over the mouth of the cave or the cave deposits, Prof. Dawkins remarks: "The probable date of the introduction of the contents into ossiferous caves in glaciated areas may be ascertained by an examination of the river deposits. If the animals found in the caves inhabited the surrounding country after the melting of the ice, their remains will occur in the post-glacial gravels. If they are not found, it may be inferred that they had retreated from the district before the latter were deposited" (p. 410); and, as Mr. Tiddeman has pointed out, there could be no pre-glacial remains in the gravels where there had been glacial erosion, as that must have swept out all the incoherent river deposits. By this test, Prof. Dawkins goes on to say, "the Pleistocene strata in the Victoria Cave, near Settle, may be considered pre-glacial, as well as the hyæna den at Kirkdale" (p. 411).

It was once thought that we were getting the direct evidence we sought for. At the entrance of the Victoria Cave, says Prof. Dawkins, "ice-scratched Silurian grit-stones are imbedded in the clay, which abuts directly on the cave loam, and passes insensibly into the clay, with angular blocks of limestone, within the cave. They may possibly be the constituents of a lateral moraine *in situ*, as Mr. Tiddeman suggests, or they may merely be derived from the waste of boulder-clay which has dropped from a higher level,"—that is, from the broken ground seen in the accompanying sketch on the left of the Victoria Cave. "The latter view seems to me to be most likely to be true, because some of the boulders have been deprived of the clay in which they were imbedded, and are piled on each other with empty space between them, the clay being carried down to a lower level and re-deposited" (p. 121).

Though we cannot yet make out clearly the relation of man to the glacial period, or explain the gap between palæolithic and neolithic deposits, this we do know—that man lived in this country and throughout Western Europe with the lion and hairy elephant, the hyæna, and woolly rhinoceros. He was probably more or less nomadic, following the urus and the elk, and shifting from place to place as they migrated with the seasons. That in his weapons of warfare and the chase he resembled the dwellers on the shores of Arctic seas, and from the associated animals probably lived when continental conditions and higher mountains produced much greater extremes of climate than are found in the same countries now. In many places he probably followed hard on the receding glaciers, before the advance of which, perhaps, his ancestors retreated. That although we cannot assign a date to his first or last appearance, we must refer him to a period so remote that wide valleys have been scooped out and whole races of animals have been exterminated since his time, but how long it took to bring this about we cannot yet tell.

Prof. Dawkins having qualified himself for the study by

acquiring an intimate knowledge of the osteology of the animals apt to be found in such places, has been long engaged in collecting the evidence which caves furnish as to the early inhabitants of Europe, and has given us the result of his researches in a very readable volume, which, we doubt not, will reach another edition, and reappear with the correction of many small inaccuracies and inconsistencies, such as would be likely to occur in putting together the evidence collected through a series of years, during which Prof. Dawkins' own views were undergoing some change as new evidence was forthcoming, and the researches and views of other observers were being brought before him.

#### OUR BOOK SHELF

*The Descent of Man, and Selection in relation to Sex.* By Charles Darwin, M.A., F.R.S. Second Edition, revised and augmented. Pp. 688. (Murray: 1874.)

SINCE the first edition of this great work was reviewed in these pages (*NATURE*, vol. iii., pp. 442, 463), it has been repeatedly reprinted without any important change. But the new issue differs, not only in form, but also in many important additions, from the first. In spite of the added material, the whole work is now comprised in a single volume scarcely larger than one of the previous two. For this purpose the print has been much compressed, and the paper is thinner. The leaves have also been cut. So that although in some respects more convenient, the present form is less pleasing than the original one. We would suggest the desirability of publishing a library edition of this and Mr. Darwin's other works, uniform with "Animals and Plants under Domestication," so that the *opera omnia* of our great biologist may stand ranged in a well-ordered row, printed in legible type with ample margin on opaque paper, fit to be clad in the sober dignity of russia. The present volume looks more like a school cram-book than a treatise which makes a generation illustrious. A prospectus has just reached us from Stuttgart of a German translation of the works of Mr. Darwin, by Victor Carus, to be published in numbers, with photographic and woodcut illustrations, portrait, indices, &c., and to be completed in ten handsome volumes. It would surely not be creditable were there to be no corresponding edition in English.

A list of the principal additions and corrections made in this edition of the "Descent of Man" is prefixed, and shows at a glance that the most important additions have been on the subject of Sexual Selection.

The whole treatise is now divided into three parts: The Descent of Man; Sexual Selection generally; and Sexual Selection in relation to Man. The two somewhat disjointed sections of the original work are thus combined into more of an organic unity. Beside innumerable references to the vast literature bearing on the subject scattered through the periodicals and books of travel of the civilised world, there is an important contribution by Prof. Huxley, on the resemblances and differences between the brain of man and that of apes, which occupies seven closely-printed pages. This and other valuable additions make this edition necessary to biologists as a work of reference, though most will probably prefer the earlier one for reading. P. S.

*Manuals of Elementary Science. Zoology.* By Alfred Newton, F.R.S. (Society for Promoting Christian Knowledge, 1875.)

A BIRD'S EYE view of a science from the hand of one who, during many years, has devoted most of his thinking time to the investigation of its principles and details, is certain to have a vigour and freshness about it which must be as

instructive as it is interesting to all who take the opportunity of glancing at it. There is a routine about educational works which is rarely diverged from to any considerable extent. Beyond the information they contain there is always a mass of oral tradition, glimpses into which only occasionally appear in print. This becomes, in many cases, the basis of the higher work of the succeeding generation, and to the student it is an invaluable adjunct to his more formal reading. In the small book before us, Prof. Newton has touched upon some of these less familiar points, bringing to the foreground several questions, the importance of which in the general economy of nature is scarcely sufficiently appreciated. He commences by a most instructive analogy, comparing the different members of the animal kingdom to a mixed collection of coins in a bag, whose history is to be determined mostly from what is to be found on their surfaces. Some, like fossil forms, are no longer current; in other words, they are extinct. Others, in their stamping give indications of the histories of the nations by which they were struck, as do organised forms by their external shape and internal structure; and so on. Upon this basis the principles of classification are, on an evolutionary foundation, established in a most lucid manner. An anecdote, particularly to the point, shows the fallacious reasoning into which students are likely to fall when they lay too little stress on the accuracy of the most minute facts, the mistake of a distinguished French naturalist with regard to the habits of the swallows found at Rouen being the instance given. The section on Geographical Distribution, when read in connection with the small map which is introduced, is as definite and precise as can be desired; at the same time that the observations on the effects of peculiarities in the physical conditions of life on the organisation of species have a bearing the full significance of which Prof. Newton has done so much to indicate. The remarks on nomenclature will also be fully assented to by all working naturalists. One of the chapters is devoted to a rapid sketch of the different classes of the animal kingdom; and this, when taken in connection with those on the subjects above mentioned, makes the little volume as complete an introduction as can be desired to the science of which it treats.

#### LETTERS TO THE EDITOR

[The Editor does not hold himself responsible for opinions expressed by his correspondents. Neither can he undertake to return, or to correspond with the writers of, rejected manuscripts. No notice is taken of anonymous communications.]

#### Marine Boulder Clay, and other Deposits

It seems from the concluding paragraphs of the report of the Challenger Observations in *NATURE*, vol. xi. p. 116, that the dredge has at length settled the question of the mode of deposition of marine boulder clay, and shown that in the Southern Ocean it is now being formed over areas perhaps as great as those now covered with similar deposits in the northern hemisphere. The facts stated show (1) The deposition of a bed of mud and sand with fragments of stones from floating ice; (2) That this deposit is so rapid as completely to mask or supersede the ordinary deposition of organic slime; and (3) That in certain areas of deep water there is a possibility that an excess of carbonic acid may remove all trace of calcareous organisms. It is further to be observed that, owing to the small amount of land, the conditions are probably much less favourable than those which existed in the north at the time of the great Post-pliocene subsidence.

These facts appear to me to confirm the conclusion which I have so often stated with reference to the boulder clay or "till" of North America, and which I have endeavoured to establish by the nature of the deposits now taking place in the areas of ice-drift on the coast of North America, by the distribution and chemical characters of the boulder-clay itself, and by the occurrence of marine fossils in it. It is to be hoped that in future we shall not have so confident assertion as heretofore, that these

remarkable clays are due to the action of land ice, and that they will cease to be regarded as affording evidence of a "continental ice-cap" in temperate latitudes.

The details given in the same communication with reference to the formation of a "red clay" from the decomposition of organic ooze, in connection with the remarks of Prof. Williamson in *NATURE*, vol. xi. p. 148, are also very suggestive. They help to account not merely for certain red clays and slates and beds of silicious organisms, but also for the association of glauconite and other hydrous silicates with organic marine beds of all ages; an association which I have long held to be not accidental, though its precise chemical conditions may be obscure. The time may not be distant when geologists may learn to regard many deposits of this kind, from the Serpentine, Logonite, and similar minerals of the Laurentian up to the Modern Greensands, as products connected with the animal life of the sea, or dependent on it for their accumulation. Some chemical suggestions bearing on this will be found in Dr. Sterry Hunt's recent volume of "Chemical and Geological Essays," which I would commend to the study of all your younger geologists.

McGill College, Jan. 20

J. W. DAWSON

#### The Transit of Venus

AMONG the brief telegraphic accounts given in *NATURE*, vol. xi. p. 122, of the work done by the several Transit expeditions, is one from Janssen, in which it is stated that Venus was seen over the sun's corona before contact (which contact, external or internal, is unfortunately not mentioned).

The idea of the rim of light round the planet being due to the corona does not seem to have struck other observers; and there are one or two points, gathered from my own observations, for and against the conclusion, that I may perhaps be pardoned for bringing forward.

For the coronal view, then. I looked for, but failed to see, the retreating edge of the planet after last external contact. The air, however, was less steady than in the morning, and my eye was very weary with straining at the last tiny indentation made by Venus on the sun's limb.

Against the theory there are the facts that the line of light was apparently of equal thickness throughout, and at half immersion was visible up to the sun's limb without perceptible loss of light; that at first internal contact, or rather when the cusps had almost united and the solar light was but little cut off (vide A in diagram), the last portion of the ring was undiminished in brightness. Finally, in the pencil notes taken at the time, I find, referring to the ring of light, these words: "A brighter spot on lower limb, entering sun about  $\frac{3}{4}$  immersion" (vide B). This spot I then imagined to be due to a portion of the planetary atmosphere, freer from cloud, and therefore refracting more light than the rest.

Taking Janssen's view, it may be accounted for by presuming the planet to have travelled over a bright streak of corona, or possibly an elongated prominence.

It will be interesting to know whether coronal structure was seen by any of the observers.

E. W. PRINGLE

Manantoddi, Wynaad, Jan. 15

#### Ants and Bees

IN his recent paper on "Ants and Bees," Sir John Lubbock is reported to have said—alluding to the bees which had tasted the honey he had set for them:—

"If bees had the means of communicating knowledge, no doubt these bees would have told the others in the hive where

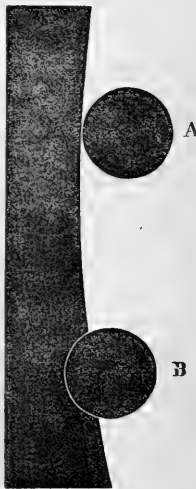

they could obtain a good store of honey with very little trouble, and would have brought a lot back with them."

Later on he says that he has come to the conclusion that what sometimes "appeared like affection was invariably dictated by selfishness."

Now, is the example given by Sir John of the want of communicative power afforded by the bee sufficient, or, indeed, any evidence of the fact? Is it not rather an excellent instance of the intense selfishness which governs the bee, in common with all other creatures, in its aim to prolong the life of the individual without a care for that of its fellows?

Again, Sir John says:—

"It was not altogether a selfish feeling which induced bees to show such eagerness to gather honey, for what they took to the hive was for the good of the whole colony."

This act seems to me to be in no way inconsistent with absolutely selfish motives. Bees find that there is strength in union, and that the winter months, which would kill them if left alone, they can survive by adopting principles of co-operation. The stronger the individual bee the more likely is she to derive benefit from the partnership, and a hive may, in fact, be regarded as a "tontine" association.

Lastly, when Sir John Lubbock says—"With regard to swarming bees by beating the warming pans, he thought there was nothing in it, but that it was an idea which had got possession of some people in the same way as many savage tribes believed that by making hideous noises during the eclipse of the moon they could frighten away the evil spirit which held her"—he would appear to have overlooked the fact that this is a practice arising from the peculiar ownership, of which, under English law, bees are the subject.

"Bees are *ferre natura*, but when hived and reclaimed a man may have a qualified property in them, by the law of nature as well as by the civil law" (Puff. c. iv. c. b. s. 5., Inst. 11, l. 14.) "Though a swarm," says Blackstone, "lights upon my tree, I have no more property in them till I have hived them than I have in the birds which make their nests thereon, and therefore, if another hives them he shall be the proprietor; but a swarm which flies from and out of my hive are mine so long as I can keep them in sight and have power to pursue them, and in these circumstances no one else is entitled to take them."

Hence the origin amongst villagers of pursuing a swarm with the clamour of pans and fire-irons; not for the benefit of the bee, *quid* bee, but in order to inform others that the followers are the possessors of the swarm.

It is easy to imagine that now some villagers may (confounding cause and effect) assert that the sound assists the operations of the bees or those of their hiver.

ALFRED GEORGE RENSHAW

Doctors' Commons, London

**On the Value of the so-called Chameleon Barometer as an Hygrometer**

A PIECE of filter paper soaked in a strong solution of cobaltous chloride (CoCl<sub>2</sub>) is blue when dry, and red when moist; and I have found it very sensitive to slight changes in the quantity of moisture in the atmosphere, being more delicate than the thermometers I used.

The paper was suspended in a room, on the wall facing a south window, which was kept open during the day. By the side of the paper was hung a wet and dry bulb thermometer, reading to 2° Fahr., and observations were recorded three or four times a day for nearly a year.

I adjoin a few of the readings taken, as from their regularity it is unnecessary to give them all. The scale of change of colour was reckoned from 0 to 10, from red to blue.

It will be observed that for a difference of 13° between the two thermometers, the paper is quite blue, and it becomes red at a difference of from 1° to 3°. There is, of course, a limit to the change of colour, as when blue it cannot be any more blue, although the air should lose moisture. However, on the hottest day last summer it stood at 10, or maximum blue, for a difference of 13° between the thermometers, and when this difference fell to 12° the paper showed a decided change in tint.

It appears that the *actual* temperature has nothing to do with the colour of the paper, as it registers the same tint for the same difference between the two thermometers (with very slight variations) whether the day be hot or cold.

I think that such a paper is a handy addition to the thermo-

meters, as you can see at a glance whether the air is wet or dry.

DATE.	Dry-bulb Thermometer.	Wet-bulb Thermometer.	Difference.	Colour of Paper.	REMARKS.
July 8, 1874.					
1.30 P.M.	72	60	12	9	
5.30 "	74	61	13	10	Very hot day.
12.30 "	70	59	11	8½	
July 10.					
9.30 A.M.	74.5	65	9.5	8	Much hotter than the 8th, and yet paper not so blue.
1.30 P.M.	77	67	10	7	
5.30 "	79	67	12	9	
Sept. 30					
1.30 P.M.	62	56	6	3	Barometer falling for rain.
8.0 "	64	6r	3	2	
Oct. 1.					
9.30 A.M.	62	58	4	0.5	Rained in night.
10.30 P.M.	63	59	4	x	Barometer rising.
Oct. 2.					
1.30 P.M.	59	55	4	0.5	Bar. fallen, showery.
6.40 "	58	53	5	x	Bar. steady, cleared up. These two days show the paper to be more sensitive than the thermometers.
Oct. 23.					
1.30 P.M.	52	48	4	x	Wind N.
6.30 "	55	54	1	0	Wind W.
Dec. 3.					
10 A.M.	43	40	3	2	Sharp frost.

Rugby, Jan. 16

A. PERCY SMITH

**Phosphorus and Carbon Disulphide**

KNOWING the highly refractive power of phosphorus, and also of carbon disulphide, it occurred to me that a solution of the former in the latter might yield a liquid more highly refractive than any I had yet met with.

I could not succeed in making a solution so saturated that when another piece of phosphorus was put in it should not be affected. I made, however, an exceedingly concentrated solution. This solution had to be filtered. The clear liquid had the property of continually precipitating phosphorus, in what I believe was the red form. The solubility of phosphorus in carbon disulphide is very remarkable. Has it a definable limit? or is phosphorus, at ordinary temperatures, really a very viscous fluid?

Also I made a perfectly saturated solution of sulphur in carbon disulphide. This was much more easily accomplished, and it showed no tendency to change from its condition of a clear light-yellow coloured fluid.

A hollow glass prism, angle 60° was used, and kept in position of minimum deviation for sodium light for each substance.

Values of Refractive Indices are given in the following table:—

*Refractive Indices.*

	Lithium a.	Hydrogen C.	Sodium D.	Hydrogen F.	Hydrogen G.
P in CS <sub>2</sub> at 51.4° F.	1.7548	1.7749	1.7780	1.8136	—
S in CS <sub>2</sub> at 51.4° F.	—	1.6840	1.6890	1.7254	—
CS <sub>2</sub> alone at 51.4° F.	—	—	1.6321	—	—
Flint glass at 51.4° F.	—	1.6193	1.6244	1.6370	1.6470

The hydrogen lines were obtained by a Geissler tube.

I do not give the measurements as more than near approximations, as I had no time to repeat them. They were made in the Cavendish Laboratory at Cambridge.

Harrogate, Jan. 21

CHAS. T. WHITMELL

**The Micrographical Dictionary—Pollen Grains**

IT is a pity that Mr. W. G. Smith (NATURE, vol. xi. p. 286) did not take the trouble to satisfy himself of the truth of Dr. Hugo

Mohl's statement, that the pollen of *Mimulus moschatus* and *Mimulus luteus* takes several forms, before writing his letter. I may inform him that the figure—in the "One Thousand Objects"—to which he alludes was not copied from the "Micrographical Dictionary," as he states. Had Mr. Smith first taken the pains to read what so excellent an authority as Dr. Hugo Mohl has written on pollen, and seen his figures, perhaps his remarks would have taken a different form. He may have observed but one form or one aspect of the pollen grains of *Mimulus* differing from the figures criticised, yet botanists will hesitate to accept his interpretation in opposition to so excellent a physiologist as Dr. H. Mohl, on the faith of his *ad captandum* observations.

M. C. COOKE

### OUR ASTRONOMICAL COLUMN

VARIABLE STARS.—Amongst the stars which deserve attention on account of probable variability, the following may be mentioned; we take them in order of right ascension.

1.  $\lambda$  Eridani, first suspected by the late Capt. Gilliss, of the U.S. Naval Observatory, Washington. It has been variously estimated between mag. 4 (Lalande, Argelander, Heis) and 6 (Gilliss, Santini).

2.  $\beta$  Herculis. The variation of this star hardly admits of doubt. It is called 6 mag. by Flamsteed, Bradley, Piazzini (who observed it nine times), Taylor, and Robinson, and is so entered on Wolfers' Chart; Lalande calls it 7, and this is the magnitude assigned in the Radcliffe observations 1867-68. Bessel and Argelander (in the "Durchmusterung") considered it only 8; Gilliss also drew attention to this star.

3. Lalande 31384. In the "Histoire Céleste," p. 291, this star is called 6 $\frac{1}{2}$ . Sir John Herschel, in his third series of observations with a 20-ft. reflecting telescope, estimated it 5, and remarked that it is not in Piazzini. Bessel and [Santini, who has four observations, call it 7; it is 5 $\frac{1}{2}$  in the "Durchmusterung," and 6 on Bremicker's Chart.

4.  $\delta$  Aquilæ looks suspicious; D'Agelet has four observations, 6, 4 $\frac{1}{2}$ , 6, 6; Lalande two, 3 $\frac{1}{2}$ , 4; it is 5 in Piazzini, 4 $\frac{1}{2}$  in "Durchmusterung."

5. Piazzini XXI. 21. D'Agelet, who observed this star twice, calls it 8 on one occasion, and 9 $\frac{1}{10}$  on the other. It is 8 in Piazzini, 6 and 6 $\frac{1}{2}$  in Lalande, 9 in Bessel, and 7 $\frac{1}{2}$  in Argelander (Durch.)

6.  $\gamma$  Andromedæ. This star has been variously estimated between 3 $\frac{1}{4}$  and 7. Flamsteed says 4, Bradley 7, D'Agelet 3 $\frac{1}{4}$  in 1783, and 6 in 1784; Lalande twice calls it 5, and once 4; Piazzini, who has ten observations, 7; it is 4 in the Atlases of Argelander and Heis, and 3 $\frac{1}{2}$  in the first Radcliffe catalogue. Bradley and Piazzini compared with the Oxford catalogue, in which much attention was given to magnitudes, appear to certify the variability of light.

Piazzini  $\lambda$ , 16 Leonis Min., and  $\beta$  Vulpeculæ, one of Gilliss's suspected stars, also deserve attention, and observations of  $\chi$  (Bayer) Cygni are especially desirable, great perturbations having been exhibited in the times of maxima of late years, which, with others previously indicated, it has not yet been found possible to represent satisfactorily by any formula. The variable is the true  $\chi$  Cygni, Flamsteed having affixed this letter to his No. 17 in this constellation; the cause of it is now understood, [Bayer's  $\chi$  having been faint at the dates of Flamsteed's observations. The var. has (1875 $\cdot$ 0) R.A. 19h. 45m. 46s., N.P.D. 57 $^{\circ}$  24'.

Prof. Schönfeld, in his new catalogue, enters the Rev. T. W. Webb's variable in Orion, as  $\delta$  Orionis, and places it (for 1855) in R.A. 5h. 21m. 51s., and N.P.D. 94 $^{\circ}$  48' 7". As a first rough approximation to elements, he fixes a minimum to the beginning of December 1872, and assigns a period of from thirteen to thirteen-and-a-half months, the limits of variation 8 $\frac{3}{4}$  to less than 12 $\frac{3}{4}$ .

OCCULTATION OF ANTARES, 1819, April 13.—We refer to this occultation on account of an interesting observation made by Burg at Vienna. He records the emersion on the dark limb of the moon at 12h. 3m. 22s. or 23s. apparent time, but remarks that at 12h. 3m. 17s. he noted the emergence of a star of from sixth to seventh magnitude, which after nearly five seconds suddenly appeared as a star of the first magnitude; and, writing to Bode, he suggests that Antares might be a double star, with the companion so close to the principal star, that good telescopes had not shown it. Bode's explanation was not a happy one. In a note he remarks: "Antares is no double star," and he goes on to attribute the phenomenon witnessed by Burg to the intervention of a lunar atmosphere. The Vienna observation, however, proves that the small star was then separated from the large one by a measurable quantity. It may be remembered that at the emersion of Antares in the occultation of 1856, March 26, which was observed by the late Rev. W. R. Dawes, at Waterbury, and Mr. Whitbread, F.R.S., at Cardington, both observers noted the interval between the appearance of the small blue star and its bright neighbour as seven seconds; the difference of colour was very marked on this occasion; Burg does not refer to it. Occultations of Antares are coming on again, but no one of them is visible in this country up to the end of the year 1878.

ENCKE'S COMET.—From M. Stéphan's observations at Marseilles on January 27 and 29, published in M. Leverrier's *Bulletin International* of the 11th inst., it appears that Dr. von Asten's ephemeris gives the comet's place with great precision; indeed, the error on the 29th (the best observation) was less than fifteen seconds of arc. M. Stéphan remarks:—"La comète offre l'apparence d'une petite tache laiteuse, à peine perceptible, produisant sur la rétine plutôt des pulsations intermittentes qu'une sensation continue." We are able to add, that on the 31st ult. it was the *extremum visibile* with a 7-inch refractor. The following positions are for 8 P.M. Greenwich time:—

	R.A.	N.P.D.	DISTANCE
	h. m. s.	° ' "	from the Earth.
Feb. 21	10 25	81 53	1'818
" 23	10 33	80 41'0	1'798
" 25	10 49	80 16'1	1'776
" 27	10 33	79 50'7	1'754
March 1	10 27 45	79 24'7	1'730
" 3	10 26	78 58'2	1'705
" 5	10 37 16	78 31'1	1'678

WINNECKE'S COMET.—Prof. Oppölzer considered that the error of his predicted time of perihelion passage in the present year would probably not exceed two hours. We find, on comparing the Marseilles observation on the morning of the 2nd inst. with his elements, that the error is likely to be within this limit, or about 0 $^{\circ}$  0' 764, the predicted time too late. With this correction the error in geocentric longitude disappears, and that in latitude is very trifling.

### MR. HAMILTON'S STRING ORGAN

IN the *Philosophical Magazine* for February there is a paper by Mr. R. Bosanquet on the mathematical theory of this instrument, in which, however, as it appears to me, the principal points of interest are not touched upon. As the remarks that I have to offer will not require any analysis for their elucidation, I venture to send them to NATURE as more likely than in the *Philosophical Magazine* to meet the eyes of those interested.

The origin of the instrument has led, as I cannot but think, to considerable misconception as to its real acoustical character. The object of Mr. Hamilton and his predecessors was to combine the musical qualities of a string with the sustained sound of the organ and harmonium. This they sought to effect by the attachment of



a reed, which could be kept in continuous vibration by a stream of air. Musically, owing to Mr. Hamilton's immense enthusiasm and perseverance, the result appears to be a success, but is, I think, acoustically considered, something very different from what was originally intended. I believe that the instrument ought to be regarded rather as a modified reed instrument than as a modified string instrument.

Let us consider the matter more closely. The string and reed together form a system capable of vibrating in a number, theoretically infinite, of independent fundamental modes, whose periods are calculated by Mr. Bosanquet. The corresponding series of tones could only by accident belong to a harmonic scale, and certainly cannot coexist in the normal working of Mr. Hamilton's instrument, one of whose characteristics is great sweetness and smoothness of sound. I conceive that the vibration of the system is rigorously or approximately simple harmonic, and that accordingly the sound emitted directly from the reed, or string, or from the resonance-board in connection with the string, is simple harmonic. On the other hand, it is certain that the note actually heard is compound, and capable of being resolved into several components with the aid of resonators.

The explanation of this apparent contradiction is very simple. Exactly as in the case of the ordinary free reed, whose motion, as has been found by several observers, is rigorously simple harmonic, the intermittent stream of air, which does not take its motion from the reed, gives rise to a highly compound musical note, whose gravest element is the same as that of the pure tone given by the string and resonance-board. One effect of the string, therefore, and that probably an important one, is to intensify the gravest tone of the compound note given by the intermittent stream of air.

The fact that the *pitch* of the system is mainly dependent upon the string, seems to have distracted attention from the important part played by the stream of air, and yet it is obvious that wind cannot be forced through such a passage as the reed affords without the production of sound. A few very simple experiments would soon decide whether the view I am advocating is correct, but I have not hitherto had an opportunity of making them properly. I may mention, however, that I have noticed on one or two occasions an immediate falling off in the sound when the wind was cut off, although the string and reed remained in vibration for a second or two longer. A resonator tuned to one of the principal overtones was without effect when held to the string, but produced a very marked alteration in the character of the sound when held to the reed.

It will be seen that according to my explanation the principal acoustical characteristic of the string—that its tones form a harmonic scale—does not come into play, the office of the string being mainly to convey the vibration of the reed itself (as distinguished from the wind) to the resonance-board and thence through the air to the ear of the observer. A second advantage due to the string appears to be a limitation of the excursion of the reed, whereby the peculiar roughness of an ordinary reed is in great measure avoided.

I should mention that I have not seen anything of the instrument for the last six months, in which time I understand great progress has been made.

RAYLEIGH

#### ICE PHENOMENA IN THE LAKE DISTRICT

**D**URING the severe frost at the close of last year, some excellent opportunities were afforded of observing various phenomena in connection with the formation and fracture of large sheets of ice. After the ice had attained a thickness of some inches on Derwentwater and

Bassenthwaite Lakes, the continued cold—with the thermometer for several days eight or nine degrees below the freezing-point (Fahr.), even at mid-day—caused such shrinkage in the ice that cracks of great length were now and then produced with a noise almost like the firing of a small cannon. These cracks frequently passed quite across the lake, and presented many points of interest, especially to the geologist. In some cases two cracks met at an angle, as in Fig. 1; sometimes three cracks radiated from a central point, as we may often see in a cracked plate; and occasionally one long and wide crack would appear to have shifted others crossing it, just as a fault shifts beds or veins, as in Fig. 2, where the portions were shifted about two inches, and in the same direction in the case of several distinct cross cracks.

Some of the cracks were so much as two inches wide, and presented curious and interesting vein-structures. One class of crack was vertically veined, presenting the appearance of a number of thin sheets of opaque ice placed on end close to one another. Such cases reminded me strongly of vertically banded feldstone dykes occurring a little north of Watwater. Their formation may be explained thus:—The crack when first formed is exceedingly fine, but when soon finds its way into it, and freezing *quickly*, becomes a thin vertical seam of opaque ice. A second and a third opening of the crack occurs, and a new vertical sheet is formed each time. Thus the whole crack becomes filled, as it widens, with successive vein-like sheets of ice. At one spot on Bassenthwaite Lake I observed two of these veined cracks crossing one another, as in Fig. 4; the one of less width ran for about one foot in the direction of the other, and then passed out, maintaining the same general direction as it previously had. Here then was another example of what occurs so frequently among rock-veins, the newer vein conforming for a short distance with the direction of the older, and thus at first sight giving the appearance of its having been shifted by the latter. In this connection compare Fig. 4 with Fig. 2; in the latter case the smaller cracks seemed certainly to have been the first formed. At some spots quite a plexus of intersecting cracks were seen, and it was of interest to notice how frequently this combination resembled the faults laid down upon a geological map.

Another circumstance, suggestive on a small scale of geological phenomena, was the curious way in which the ice for about a mile and a half over the course of the Derwent, as it flowed into Bassenthwaite Lake, was raised into a low and broken anticlinal. For some time after the ice had formed over the greater part of the lake, a line, first of open water and then of thin ice, followed the river course for some distance, until its waters lost their distinctness in the general body of the lake. In the meantime, from the dryness of the weather and the continuance of the extreme frost, the ice subsided with the waters, and produced a gentle upheaval over the course of the river, which upheaval, however, seemed generally to have resulted in a more or less sharp ridge usually fractured in the direction of its length, and but seldom showing cracks of any size passing quite through from one side to the other.

Cracks showing a vertically veined structure have already been mentioned; these seem in all cases to have opened little by little, and to have been quickly filled with successive thin sheets of opaque ice; they probably never stood open and full of water for any length of time, but were the results merely of the contraction of the ice under the extreme cold. Another class of cracks, however, seem to have been wide and gaping during a thaw, and to have been suddenly sealed up by the freezing of the liquid contained between the sides. It is well known that as a general rule the more quickly a body solidifies from a liquid condition the greater the number of cavities—liquid and gaseous—it will contain, the liquid being frequently

\* In the *mechanical*, not the *musical* sense

entrapped in the growing solid, and the gas not having time entirely to make its escape. In the case of many of these open cracks it would seem that the freezing took place so rapidly when it once began, that the air could not be all expelled, but the air-bubbles were lengthened out in their endeavour to set themselves free, and preserved in the form of very delicate tubes, pointing from the crack walls on either side slightly downwards and towards the centre, where solidification would last take place (Fig. 5). Along the central line of the crack occurred another series of perpendicular tubes caused by the elongation of the bubbles in the only direction then



FIG. 1.

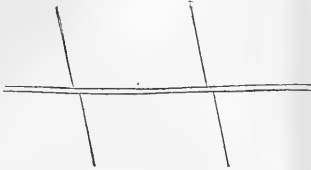

FIG. 2.

possible to them. Nothing could exceed the beautiful regularity of structure thus caused. In a few instances there was a double series of such an appearance as is represented in Fig. 5, the crack having again opened, apparently, along the same line, and a similar structure to the former having been produced. In this connection it is interesting to note the seemingly frequent evidence of fracture recurring along the same lines, especially if the explanation given above of the vertically-veined cracks be the correct one.

The drawn-out air-bubbles were also particularly beautiful around the stones and rocks in the shallow water at the edge of Derwentwater. Much of the very smooth ice which covered the lake on the morning of Wednesday, the 23rd of December, had been formed under a very sharp and sudden frost, the thermometer in a sheltered position registering  $18^{\circ}$  of frost. The ice would first form around the stones in shallow water, and form more quickly there than out in the open, where there were no marked centres of crystallisation; hence the number of bubbles entrapped were greatest around the stones and rocks close to the surface, at the lake-edge;



FIG. 3.

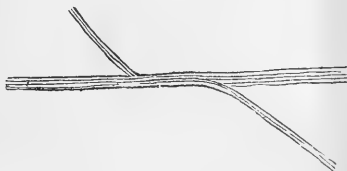

FIG. 4.

and the bubbles, trying to escape downwards as soon as the upper layer of ice was formed, became beautifully drawn out and fringed the stone most delicately. I have occasionally observed a somewhat similar lengthening of gas or liquid cavities when examining thin slices of such rocks under the microscope as have undergone solidification under tension in one given direction.



FIG. 5.

Before closing these few remarks, allusion may be made to two other effects noticed during the late frost. One of these is the precise analogy between the deposits of ice often formed on a rocky slope, or by constant dripping from above, and the deposits of carbonate of lime formed in caverns. The trickle of a thin stream of water over a rocky slope, such as may be seen in many parts of the Clapham

Cave, deposits a wrinkled wavy layer of carbonate of lime, and over it the water seems ever to keep up a rhythmic flow. Upon rocks near the summit of Honister Pass I noticed during the late frost an icy sheet precisely similar, and with the same pulsating streamlet flowing over, while, hard by, there were sheets of icy stalactite and stalagmite only to be distinguished from those of limestone caverns by their greater clearness.

Another feature of great beauty was the effect of the bright sunshine on the icy crystals scattered broadcast over the snow of Skiddaw. Looking slightly away from the sun at a certain angle, and inclining one's head so as to look along the ground, there appeared scattered in boundless profusion thousands of brightly coloured gems, blue and green being the most marked colours, but many a ruby lying interspersed with these mountain emeralds. Assuredly Skiddaw top never showed to greater advantage than during those cloudless wintry days of the Christmas and following week; and it seems a marvellous pity that of the thousands who visit this favoured spot during the hot days of summer or the wet ones of autumn, so few should ever return to see their majestic friends

"Clothed in white samite, mystic, wonderful."

It may interest some to learn that something analogous to a Swiss glacier was once observed among our Cumberland mountains. Beneath the summit of Dale Head, 2,500 feet high, is an old copper mine, and many years since two miners entered the old workings in the month of June to obtain some mineralogical specimens. Great was their surprise to find the level, but a short way in, full of snow and ice. The mountain-slope is there very steep, but with many a hollow and rugged fissure in which the snow lies long, and doubtless it had found its way from above into the old level, as well as having been blown in at the mouth. The trickling of tiny streams among this snow, and the alternations of frost and thaw so frequent upon the mountain sides, must have produced an icy mass, which would be long ere it melted, and thus a natural ice-house was well supplied with ice far into the summer. The winter previous had, I believe, been a very snowy one, and it is not likely that the phenomenon is of very frequent recurrence.

J. CLIFTON WARD

#### SCIENCE AT BANBURY

AT the opening of a new Literary and Philosophical Society at Banbury the other day, Mr. B. Samuelson, M.P., gave an inaugural address in which he touched on various topics connected with the progress of science and scientific culture. We regret that our space prevents us from giving Mr. Samuelson's address at length; the following extracts, however, we believe, will interest our readers:—

"There have, doubtless, been times when the pursuit of learning was carried on with as much ardour, when as great sacrifices were made for the discovery of truth, or when there was at least an equal toleration for differences of opinion, as in our generation; but I think it may safely be asserted that at no period since the revival of letters in the fifteenth and sixteenth centuries have these conditions, essential as they are to the success of our objects, existed to the same extent as in our day. It may not be one of the least useful and interesting subjects of inquiry for our society how this favourable conjuncture has arisen. Probably it will be found to be one, and if so, certainly not one of the least important, of the results of the great material changes which have their origin in the substitution—begun in the age of Watt, and still in course of development—of machinery for manual labour. At any rate we may congratulate ourselves that the experience of the present age proves the dogma to be fallacious which

asserts that material wealth is necessarily associated with the decadence of intellectual vigour, or of the sense of moral responsibility. What the Roman poet said of the Augustan time, 'Actas parentum peior avis tulit nos nequiores, mox daturos progeniem vitiosorem,' cannot with truth be said of our age and country. . . .

"Our funds will of necessity be limited at first, and it will hardly be in our power for some time to come to procure for our subscribers regular courses of lectures either in literature or science. Nor, indeed, do I think that the ordinary popular lectures are on the whole of any permanent value beyond the intellectual excitement which they produce. Their tendency in too many instances is rather to discourage than to promote study. When we have witnessed the brilliant experiments and listened to the luminous expositions of a Tyndall on light or magnetism, we are too apt to imagine we have carried away the solid instruction in those sciences which is in fact only to be acquired by close and persevering application. And this applies equally to literature, as those amongst us who were charmed by the acute criticism and pungent satire of Thackeray in his day will scarcely fail to admit. I believe that we should do more good by having, in each of our sessions, one or two lectures by eminent men, setting forth the objects and boundaries of some great branch of literature or of science, and the best method of cultivating it. Such lectures would do as much as popular courses to awaken the interest of those hitherto unacquainted with the subject treated, and would stimulate them to private study; whilst they would be of greater value to those who have already some familiarity with it by enabling them to keep abreast of the most advanced knowledge of the day and directing them to lines of inquiry by following which they themselves may possibly extend its boundaries. . . .

"As an example of how little the theory of force is apprehended even in its most rudimentary form, by persons who have received a liberal education, I may mention the case of a landowner and member of one of the learned professions, who not long since consulted me about his barn machinery. He suggested water as the motive power, and, when I asked him how he would obtain the necessary fall, gravely proposed to raise the water from a canal at the foot of his homestead, by the very machinery which that water was to set in motion.

"It is probable that one or more of our distinguished members, on whose support we have to congratulate ourselves, will have the kindness to give us instruction of the highest grade in their special subjects; but there is probably not one of us who could not, by working steadily at some subject in which he takes an interest, and by a simple relation of the result of his studies and observations, contribute to our entertainment as well as add to our knowledge. It is one of the advantages of residence in the country, that it affords so many opportunities for the study of the natural history of animated life. The example of Sir John Lubbock's exquisite monograph on the fructification of flowers, composed in his leisure moments by a man immersed in public and private business, as well as occupied by the special pursuits to which he owes his scientific reputation, shows how much may be done in this way. . . .

"Our holiday tours also, whether at home or abroad, if we note carefully and relate simply what we have seen, will give us endless subjects for papers on ethnology, social and political economy, and archaeology. . . .

"The establishment of a Museum is one of the objects contemplated by the gentlemen to whom we are indebted for the existence of our society, and there can be no doubt of the value of such an institution, even if it should not attempt anything beyond the collection of miscellaneous objects illustrative of natural history, and of that of our race and country. I remember well that when I was a child, the sight of a provincial collection of armour, of

coins, and of other objects of daily use belonging to a period so recent as that of the Commonwealth and the Restoration, first enabled me to form a conception of history as of a reality instead of a dream."

#### THE EDINBURGH BOTANICAL SOCIETY\*

THE Botanical Society of Edinburgh numbers more than 500 members. Moreover, the Botanical Class of the University of Edinburgh is the largest in the three kingdoms; the number of pupils which attended it in the year 1874 was 354. We might reasonably expect, therefore, to find in the "Transactions" of the Society some evidence of the existence, in an environment apparently so favourable, of a flourishing school of botanical investigation. After, however, examining the present number with some care, it is impossible to avoid feeling considerable disappointment. To speak the truth, a great part of its contents might have been sufficiently gratifying to those concerned if printed in some local periodical, but they are quite unworthy of that more formal and wider circulation which they necessarily aim at by their present mode of publication. The valedictory address of the president, Mr. J. M'Nab, is mainly occupied with a discussion (but *apart* from any meteorological data) of the deterioration of the climate of Scotland, which it is well known he believes to have taken place. Amongst other facts which he adduces in support of it, is the present scarcity in Scotland of mushrooms! He takes occasion to point out that though the British climate is unsuitable for many plants such as *Rhododendron arboreum*, their hybridised descendants are able to represent them in our gardens. It is, however, by no means certain that *Bryanthus erectus* is, as the president stated, a hybrid between *Menziesia empetriformis* and *Rhodothamnus chamaecistus*; on the contrary, it appears to be identical with a form of the former species.—Mr. A. S. Wilson continues his remarks on *Lolium temulentum*, the seeds of which have long been believed to be poisonous, and an exception to the general rule amongst grasses. The poisonous qualities of *Lolium temulentum* are attributed, no doubt correctly, to the ergot, with which it is often infected. After separating the ergotised grains, Mr. Wilson made cakes of darnel meal, which he ate without experiencing any ill effects. It is mentioned *inter alia* (p. 49) that the first Swedish turnips raised in Britain were grown at Perth, in 1772, from seed sent by Linnæus. Rather unexpectedly in a botanical publication we come further on upon an account of a dredging expedition, headed by Prof. Carus, in Lamash Bay.—Mr. J. F. Duthie gives a long account of botanical excursions near the Baths of Lucca; except as an extract from the journal of an ardent collecting botanist, it has no points of interest.

Mr. A. S. Wilson writes on the fertilisation of cereals, in which he holds, against most authorities, that wheat, barley, and oats are not wind-fertilised, but are self-fertilised before the anthers are expanded. In rye, on the other hand, his experiments led him to the belief that 56 per cent. of the florets are fertilised by the agency of the wind. There are some things in his paper to which exception might be taken. Thus (p. 95), speaking of the embryo (ovule?) of rye, he says it "may more properly be regarded as a cellular mass capable of evolving fifty embryos, one of which takes the lead in the ovary," &c. Mr. M'Nab, in a paper on "Climatal Changes in Scotland," reiterates his view already alluded to; while the annual temperature remains the same, he believes the summers to be cooler.

Dr. Stewart's list of the principal trees and shrubs of Northern India takes up nearly forty pages. It is a posthumous publication, and its precise usefulness is by

\* Transactions and Proceedings of the Botanical Society of Edinburgh vol. xiii. part 1.

no means clear. Brandis's "Forest Flora of North-west and Central India" is an admirable and scholarly book. With the preparation of this Dr. Stewart was at first associated, and the present list is apparently a rough draft of the ground intended to be covered by the more elaborate work. After testing Dr. Stewart's list in several places, it is clearly evident that it is a mere compilation of no value whatever, critical or otherwise. One example out of many will suffice: *Hopsea floribunda*, Wall., is identified with *Shorea robusta*, the well-known *Sal. A. De Candolle* fell into this error; but seeing that Wallich's specimens are in London, Dr. Stewart might easily have avoided following him. The confusion in Indian botany is already sufficiently deplorable without importing fresh mystifications.

Mr. Etheridge, jun., F.G.S., contributes a notice of some newly discovered specimens of *Pothoites*, a carboniferous fossil which has been held to represent the oldest known angiospermous Phanerogam. A note on the Chinese Lan-hwa makes Prof. Balfour by some error speak of *Olea fragrans* as belonging to the *Orchidaceae*. The remainder of the matter filling the 188 pages of this part contains nothing else worth noting.

#### THE RECENT STORMS IN THE ATLANTIC

IN reference to the suggestion contained in the last number of NATURE, p. 290, we notice in the *Times* of the 13th inst. the following telegram:—

"New York, Feb. 12.—In consequence of the continuance of intensely cold weather, the East River is totally blocked with ice, and the shipping on the Hudson River is seriously impeded. In all parts of the States travelling is almost suspended, and the present condition of things is without parallel in the history of the last forty years."

The cold weather appears to have set in during the Christmas week, and not to have abated in the end of January and the first days of February, when we in Western Europe were brought under the influence of the polar wind. It remains to be seen whether the gales abated in the Atlantic when both sides were brought under similar conditions. We find in one of the most recent numbers of the *New York Herald* a list of the several years in which the freezing of the East River occurred at New York. Our contemporary notes,—January 19, 1792; January 8, 1797; January 19, 1821; January 21, 1852; January 1854; January 8, 1856; January 17, 1857; January 23, 1867; February 1871.

It cannot be said that each of these years was cold in Europe as well as in the States; so that it may be asserted with some degree of probability that the freezing of the East River in New York, and the freezing of the Seine or the Thames, are not regulated by the same laws. Without going deeply into the matter we can say, *exempli gratia*, that in 1821 the first part of the winter was cold in Europe, but that the weather was milder among us when the East River was frozen. On the contrary, the whole of the winter in 1853-1854 was rather cold in our temperate regions. In 1857 the freezing of the East River occurred when the winter was beginning to get colder in Europe. But in 1871, the cold disastrous winter which helped so much the German armies was over, and February was rather mild, when the East River was bridged over by coalescing icebergs. Consequently the only point which can be easily settled is to ascertain whether differences of temperature between America and Europe are an indication of the existence of gales raging in mid-ocean. The interest of the suggestion is independent of the origin of the inequality of temperatures, which can be attributed to many different causes, but would take too long to enumerate, and which would lead to no immediate practical conclusion.

W. DE FONVIELLE

#### NOTES

THE British Eclipse Expedition in charge of Dr. Schuster sailed last Thursday in the Peninsular and Oriental Company's steamship *Surat*, for Galle and Singapore. Dr. Vogel, of Berlin, joins the expedition at Suez, and Dr. Jansen at Singapore. Prof. Tacchini, also a member of the expedition, is already at Calcutta. The Viceroy has chosen Camorta, in the Nicobars, and Mergui as observing stations. The English observers will proceed to Camorta, where, as Mr. Hind has already stated in NATURE, totality lasts 4m. 27s. Before the accident to the *Charybdis*, that ship had been detailed by the Admiralty for the conveyance of the observers from Singapore to Siam. The *Surat* passed Gibraltar yesterday, all well.

THE medals of the Geological Society will be awarded as follows at the anniversary meeting to be held to-morrow:—The Wollaston Medal to Prof. L. G. de Koninck, a distinguished palæontologist, especially as regards carboniferous fossils; the balance of proceeds of the Wollaston Fund to Mr. L. C. Miall, of Leeds, who has done good work on the Labyrinthodonts; the Murchison Medal to Mr. W. J. Henwood, of Penzance, for researches in respect to mineral veins and underground temperature; and the Murchison Fund to Prof. H. G. Seeley, in aid of his researches in fossil osteology.

THE medal of the Royal Astronomical Society has been awarded this year to M. D'Arrest, for his great catalogue of Nebulæ.

CAPT. HOFFMEYER, Director of the Danish Meteorological Institute, has issued a circular in reference to his admirable Daily Weather Charts, from which it is gratifying to see that they have been well received by the meteorologists of Europe. He is resolved to continue the publication, although hitherto the subscriptions have not been sufficient to cover the outlay. In the hope, however, that the number of subscribers will more and more increase, Capt. Hoffmeyer will continue to issue the charts at the same price as heretofore; he will, moreover, issue charts embracing a larger portion of the globe than before, and giving, besides, some idea of the distribution of temperature. These changes in the charts have been adopted in accordance with the advice of the directors of various central institutions. He has rejected Mercator's projection in order to avoid the exaggerated dimensions of northern regions, and he has somewhat diminished the scale in order to be able to embrace more degrees of longitude. He has also placed beside the stations figures showing in centigrade degrees the observed temperature, without the correction for altitude. Subscriptions are received at the Meteorological Office, 116, Victoria Street, London, S.W., at the rate of 12s. 6d. per quarter, including cost of delivery. We hope that Capt. Hoffmeyer will be encouraged in his most laudable enterprise by an increased number of subscribers; it is the duty of all friends of science to do what they can to support so valuable a work.

THE tercentenary of the University of Leyden appears to have been a very brilliant affair. The delegates from other universities, to the number of over seventy, were treated with boundless distinction and hospitality. They came from Claudopolis in the east, and Coimbra in the west, and from Finland in the north. Considerable disappointment was felt at no representative being sent by Oxford, and that no notice of any kind was taken of the invitation. No doubt Oxford will be able to render a reason for this seeming uncourteous conduct. The Universities of Cambridge, Dublin, and London were all represented. It is interesting to hear that amongst the honorary degrees none was received with so much applause as that conferred on Mr. Darwin.

NOTHING definite was the result of the deputation from King's College which waited on the Duke of Richmond and Lord Sandon last Thursday, to ask the Education Department to make a grant to the College from the fund for educational purposes, in accordance with the recommendations of the Royal Commission on Scientific Instruction and the Advancement of Science. The Bishop of London presented the case of the College very forcibly, and showed that it really needed and deserved help; but, as might be expected, no certain hopes were held out that any grant would, in the meantime at least, be given. It is, however, to some extent consoling to learn that the claims of the College have been talked over by the powers that be. But, as Lord Sandon said, "it is a large subject, involving other parts of the country," and it seems to us that it can only be adequately considered in connection with the duty of Government in connection with the scientific education of the country as a whole, and with the claims of scientific research.

SIGNOR TEMPLI, First Assistant at the Observatory of Milan, has been appointed to the directorship of the new Observatory at Arcetri, near Florence. The post has been vacant since the death of Prof. Donati about a year and a half ago.

THE Vice-Chancellor of Cambridge University invites the attendance of the members of the Senate on Friday afternoon, immediately after the Congregation, for the discussion of the following important Grace, which has received the sanction of the Council of the Senate:—"That a Syndicate be appointed to consider whether any, and, if any, what representations should be made to the Government as to the importance of obtaining legislative authority for modifying the pecuniary and other relations subsisting between the University and the Colleges, and for enabling the University thereby to enlarge and improve its system of education."

THE Cambridge Museums and Lecture Rooms Syndicate draw attention to the increased necessary expense in maintaining the departments under their charge, and ask for an increase of 500*l.* a year to their annual grant—that is, 2,000*l.* instead of 1,500*l.* They point out that the Cavendish Laboratory requires a considerable annual outlay. The expenditure has been restricted on all sides, and the purchase of specimens which would have helped to fill important gaps in the collections has had to be declined in consequence of want of funds. The Syndicate also ask for leave to expend 60*l.* for fittings to the Geological Museum. The Vice-Chancellor invites the attendance of members of the Senate to discuss this report in the Arts School to-day, immediately after the Congregation.

THE *Sussex Daily News* publishes a letter from Mr. Henry Willett, hon. secretary to the Sub-Wealden Exploration Enterprise, defending the course adopted in commencing the second boring on the same site. To have done otherwise would have caused much delay and inconvenience. The decision appears to have given general satisfaction, there having been an encouraging accession of subscriptions. A depth of 40 feet has been reached in the new boring.

THE publishers of *Naturforscher* have just issued the first number of a monthly periodical which promises to be of very great service to workers in science. It is entitled *Repertorium der Naturwissenschaften*, and its purpose is to give monthly a list of the most recent papers in the various departments of physical and natural science. Only such papers are mentioned as describe the results of original research, and the titles are arranged under that of the particular publications in which they are contained, and which consist mainly of the Proceedings of the various scientific societies, foreign and British, along with some of the principal scientific journals. The intention seems to be to give the titles of all original papers wherever they

appear, and no doubt, as the publication advances, its plans will be improved and developed. We would suggest that the names of editor and publisher, and the place of publication, should in all cases be given. The enterprise deserves the greatest success. The editorship is the same as that of *Naturforscher*.

AT Berlin a telegram has been received from the commander of the *Gazelle*, dated Akyab, the 15th inst., announcing that the observations of the Transit of Venus at the Kerguelen Islands were successful. Further accounts from Dr. Janssen show us that he was enabled to observe Venus eclipsing the coronal atmosphere of the sun, by using glass of a deep blue tint.

SOME amusing and characteristic blunders have been committed by the *Journal Officiel* of the French Government in its impression of the 13th February, when describing the observations of the Transit of Venus at the Sandwich Islands. The official journalist says that the Sandwichians looked at the transit with *blackened glass*, without the help of any telescope. He supposes, moreover, that Cook observed the transit at the Sandwich Islands in his second voyage. The fun of the blunder is that Tahiti, where the transit was observed, is now a French settlement.

WE learn from the *Kölnische Zeitung* of Jan. 29 that at the last meeting of the Academy of Sweden, Prof. Norden-skjöld intimated that M. Oskar Dickson, of Göteborg, has granted the means for a new Arctic Expedition, which is to leave Sweden in the spring of 1876 for Nowaja Semlja and the Kara Sea, in order to continue in these little investigated countries the scientific researches commenced by Swedish explorers on and round Spitzbergen.

THE February number of Petermann's *Mittheilungen* contains a new map of Chili on the scale of 1:500,000, along with a brief account of Chilean cartography. The same number contains a Geographical Necrology for 1874; a paper, by Prof. Hans Höfer, geologist of the Wilczek Polar Expedition, on the icebergs of Novaya Zemlya, about which hitherto little or nothing has hitherto been known; the first instalment of "Travels in High Armenia in the year 1874," by Drs. Radde and Siewers; and a lecture on the scientific results of the recent Austrian Polar Expedition, an abstract of which we hope to give in our next number.

PROF. SCHNETZLER, of Lausanne, has published a paper on some researches which he made with regard to the common frog (*Rana temporaria*). He had placed fertilised eggs of frogs into colourless glass vessels, and others into green coloured ones; he found the development of the young animals to be remarkably slow in the green glasses, and ascribes the fact to the total absence of ozone in these glasses. The colourless glasses contained ozone constantly, whereas in the green ones there never was a trace.

THE *Neue Freie Presse*, in an article dated from Rudolphs-werth, in Carniola (Austria), Jan. 25, describes a slight earthquake that was felt there on that date. The oscillations began at a quarter past eight in the morning, and were repeated twice within a quarter of an hour; their direction was horizontal, the weather was dull and rainy; temperature + 10° C.

Two earthquakes have been recorded in Algeria, and, singularly enough, are recorded as having been felt at the same hour, ten o'clock in the morning, the first on the 20th January, at Tlélat, and the second at Sido-Bel-Abbes on the 29th. The direction of the first oscillation was from south to north. Nothing is said of the direction of the second.

THE *Kölnische Zeitung* of Jan. 31 reprints a long article, taken from the *Göttinger Zeitung*, in which Prof. Klinckferus severely criticises the German custom of admiring everything

that is foreign and deprecating native talent; he does this with special reference to an article which appeared in many papers in Germany, stating that the French astronomer, M. Camille Flammarion, had succeeded in determining the actual weight of a distant fixed star, and had found it to be about three times the weight of our sun. He points out that the result is correct, but is not a discovery of M. Flammarion. Prof. Krüger (now director of the Observatory of Helsingfors) had already in 1859 made and published his calculations, after having received from the writer a more exact determination of the orbit of the double star in question,  $70\beta$  Ophiuchi. Prof. Krüger then gave the following details: Mass of the double star =  $2.74$  times that of the sun; half of the major axis =  $29.34$  times our distance from the sun; distance from our solar system =  $1,200,000$  times the sun's distance from the earth. The ray of light requires  $19\frac{1}{2}$  years to travel from the star to us (about the same time, Prof. Klinkerfues says, that German works take to become known in France). When the parallax of the star was determined still more perfectly, Prof. Krüger altered the above figures to  $3.12$ ,  $30.3$ , and  $1,271,700$  respectively.

THE discovery is announced of a new planet (142) by Director J. Polla, at Fola, with a telescope of  $7\frac{1}{2}$  ft. focal length. It appeared of the 12th magnitude, and on Jan. 28, at 1h. 23m. 47s. Fola mean time, under R.A. 8h. 25m. 56s. 82, and Decl.  $+18^{\circ} 17' 38''$ , with a daily motion of  $-1m. 6s. R.A.$ , and  $+2.8'$  Decl. At the Dusseldorf Observatory the planet (134) is being observed and its elements exactly calculated.

THE *Kölnische Zeitung* of Feb. 7 contains an abstract of a paper read by M. G. Wex, at the Geographical Society of Vienna, on the decrease of water in rivers and sources. The author states that the results of his observations tend to show the constant decrease of the rivers of Germany and the increase of seas. It appears from them that the levels of the German rivers are now much lower than they were fifty years ago; viz., the Elbe 17 in., the Rhine 24.8 in., the Oder 17 in., the Vistula, 26 in., the Danube 55 in. As a reason for this decrease, the author gives the progressing devastation of forests, which causes a decrease in the atmospheric moisture they attract and convey to the soil and thence to sources.

THE parasite which Dr. Cobbold proposes to describe at the Linnean Society this evening is, we understand, of singular interest. The *Distoma erassum* has only once before been observed, when it was discovered some thirty years since by Prof. Busk. The curious thing is, that in the present instance a Chinese missionary and his wife have both become the victims of this large species of fluke, several specimens of which will be exhibited to the Society.

PROF. PARKER commenced his course of eighteen lectures on the structure and development of the skull on Monday last, in the theatre of the Royal College of Surgeons. The following was his programme: 1. Introductory; 2. Skull of Lancelet; 3. Skull of Menobranchus; 4. Skull of Frogs and Toads; 5. Skull of Snakes and Lizards; 6. Skull of Turtles and Crocodiles; 7. Skull of Birds (*Ratite*); 8. Skull of Birds (*Carinate*): 1. Schizognathæ; 9. Skull of Birds (*Carinate*): 2. Desmognathæ; 10. Skull of Birds (*Carinate*): 3. *Ægithognathæ*; 11. Skull of Birds (*Carinata*): 4. Saurognathæ; 12, 13, 14. Skull of Pig; 15, 16. Skull of other Mammalia Placentalia; 17. Skull of Mammalia non Placentalia; 18. Summary and Conclusion.

THE Emperor of Germany has conferred upon Mr. George Fawcus, the author of the Isometrical Pocket Drawing-board, the Order of the Golden Crown. The board will probably be used by the Prussian staff officers.

ON Feb. 11 a numerous meeting of ladies and gentlemen inter-

rested in the subject of female education met at Prof. Holloway's, in Oxford Street, for the purpose of discussing the details of a scheme for the establishment, at Egham, of a University for Ladies. Mr. James Beal presided, and there were also present Sir James Kay-Shuttleworth, Mr. Samuel Morley, M.P., Mr. D. Chadwick, M.P., Mrs. Fawcett, Mrs. Arnold, Mrs. Grey, Mr. E. Ray Lankester, and Dr. Richardson. Mr. Holloway seems thoroughly in earnest in his proposed scheme, and has already secured a site at Egham at a cost of 25,000l. He has set apart a quarter of a million to found the institution, and is prepared to give more if wanted. A committee was appointed to seek counsel from the most competent authorities on the subject, and report to a future meeting.

A *Times* telegram states that Dr. von Neumeyer, chief of the Hydrographic Office of the Berlin Admiralty, will be appointed director of the Deutsche Seewarte, the new official institution at Hamburg for the scientific exploration of the ocean and atmosphere.

M. GRAVIER, one of the staff of the Rouen Library, has presented the French Geographical Society with the "Canarian," a history of the conquest of the Canary Islands, and conversion of the islanders to the Christian religion. This learned historian has devoted himself to describe the establishment of the French in several parts of the world, and the deeds of the French adventurers. He has published already "The Discovery of Mississippi, by Cavalier de la Salle," and "The Discovery of America by the Normans in the Tenth Century." The "Canarian" is an admirable book, narrating the exploits of Jean de Bethancourt.

THE increase in the cultivation of beetroot in Europe for the manufacture of sugar is said to be causing great loss to the cane-sugar planters in Cuba, who have been at an enormous outlay for machinery and labour to produce the fine class of sugar that is exported from thence. Should the European manufacture and consumption of beet-sugar go on increasing as it has done during the past four years, serious changes are anticipated in the cane-sugar productions all over the West Indies.

Two species of *Corchorus*, *C. capsularis* and *C. olitorius*, are generally accredited as the sources from whence the fibre well-known as jute, so largely imported for carpet and other descriptions of weaving, is obtained. These plants are chiefly grown in Bengal, but in the Madras Presidency *Hibiscus cannabinus* and *Crotalaria juncea* are popularly termed jute; so that some confusion has arisen as regards the identification of the plants yielding jute in India. This question has recently occupied the attention of the Government of Bengal, and from inquiries instituted it appears certain that the true jute (*Corchorus*) is not found in the Madras Presidency, and that the fibre sent from thence as jute is really referable to *Hibiscus* and *Crotalaria*.

It is only a very short time ago since it was supposed that the origin of the true medicinal Rhubarb of commerce had been finally settled, and was the product of *Rheum officinale*, recently figured in the *Botanical Magazine*, and admitted in Flüchiger and Hanbury's "Pharmacographia;" and already this comfortable arrangement has been disturbed. In a recent number of Regel's *Gartenflora* there is a figure of *Rheum palmatum* var. *tanguticum*, which is described as the "most genuine amongst genuine" rhubarbs, and as the sort imported into Siberia by way of Kiachta. It was raised from seed collected by Mr. Przewalsky in South-west China on the high plateau bordering on the high lands of Tibet. We are promised a review of the species of *Rheum* in an early number of the *Gartenflora*, by Maximowicz.

THE Ramie, or China grass plant (*Bahmeria nivea*), which has excited so much interest of late owing to its proposed extended cultivation in India, seems to thrive in Cayenne, specimens having been shown at a recent exhibition in that colony and compared with plants grown in France. The Cayenne plants, which were grown on a comparatively poor soil, without manure and with little or no attention, were double in size and height to those grown in France. Three successive shoots were produced in one year.

THE additions to the Zoological Society's Gardens during the past week include a Péguan Tree Shrew (*Tupaia péguanus*) from Burmah, presented by the Hon. Ashley Eden, new to the collection; a Cinereous Sea Eagle (*Haliaeetus albicilla*) from Japan, presented by Capt. Sidney T. Bridgeford; two Bonnet Monkeys (*Macacus radiatus*) from India, presented by Sir F. S. Gooch, Bart.; a Sykes's Monkey (*Cercopithecus albogularis*) from Africa; a Robbin Island Snake (*Coronella phocaronis*); a Horned Viper (*Vipera cornuta*), from S. Africa, deposited; four Four-spotted Opossums (*Didelphys opossum*) from South America, purchased.

### THE PAST AND FUTURE WORK OF GEOLOGY\*

#### II.

WE now come to the more special ground of the geologist. Starting with investigations connected with the origin of the globe, he has to trace the changes it has undergone through the various phases of its history, to determine the causes of those changes, and the manner in which they were effected. Besides dealing with inorganic matter, he has also to study the character and distribution of all organised things inhabiting the earth in all former periods, their order of succession, and the relation of the several and successive groups one to another.

Referring to the theories of the other geologists and to the philosophy of Hutton, Playfair, and their successors, Mr. Prestwich said it is a question whether the license which formerly was taken with energy is not now taken with time. Small forces long continued, action frequently repeated, and maintained uniformity of operation, are accepted as sufficient to account for the formation of our hills and plains, for the Alps and the Andes, and for all the great general as well as special features of the earth's crust.

The points at issue are, firstly, whether our experience on these questions is sufficient to enable us to reason from analogy; and secondly, whether all former changes of the earth's surface are to be explained by the agency of forces alike in kind and degree with those now in action. Mr. Prestwich then states his reasons for answering these questions in the negative:—

"The value of experience with respect to natural phenomena depends upon whether they are symmetrical and not variable, or whether they are variable and unsymmetrical. In the one case, as any one part bears a given uniform relation to the whole, if one part be known the whole can be inferred; but in the other case, where the whole is made up of unequal and not uniform parts, the value of the evidence is merely in proportion to the number of those parts independently determined, or to the ratio between the duration of the observation and the duration of the time comprising all the phases of the particular phenomenon. Thus the path of a planet, the date of an eclipse, or the return of a comet, may be predicted with certainty by the determination of mere minute sections of their orbits, which in respect to time are infinitely small compared to the length of the cycle of revolution. On the other hand, the metamorphosis of an insect, the mean temperature of a place, or the character of a volcano, can only be accurately determined by a length of observation sufficient to embrace all the variations they respectively present in their several cycles of change. In the case of the insect, the time must be equal to the duration of the metamorphosis; in that of temperature a succession of years is needed to obtain a mean; and with respect to volcanoes, centuries may often pass before we become acquainted with all the irregular exhibitions of their spasmodic activity.

"The necessity for a much greater extension of time becomes yet more imperative when we come to deal with geological phenomena, such as those due to the action of elevatory forces, which are extremely varied in their nature,—being at one time exhibited by a raised beach a few feet high, and at another by a mountain chain whose height is measured by miles; or by the small displacement produced by an earthquake, and the rectilinear fracture of a county with a displacement of thousands of feet.

"In taking into consideration the weight of the evidence where the series is so variable and irregular, it is clear that the increment of value is only in proportion to the increment of time. One phase of the insect life, one year's record of temperature, a century's observation of the volcano, give evidence which, although of value *pro tanto*, as one link in the chain, is entirely inconclusive when applied to the whole length. So in respect to such geological changes as those just named, the value of our experience is only in the proportion of the length thereof to the duration or cycle of the phenomenon under investigation. Thus the elevation of mountain ranges have been events of rare and distant occurrence. It has been estimated that all the great chains can be referred to thirteen epochs: taking subordinate ranges, the elevation of the main mountain chains of the old world may certainly be limited to twenty such periods. Divide geological time (since the sufficient consolidation of the crust of the earth) by this or even by double this number, and we may form some conception of the length of the cycles involving changes of this magnitude. What that time was it is impossible to say; we can only feel how infinitely it exceeded all our limited experience. With respect thereto the experience of five hundred years is no doubt of value—one or two thousand years add further to it;—but after all, how insignificant that duration of time is compared to the time over which the cycle extends; it may be as 1 : 100, or it may be as 1 : 200 or more, and I shall show presently that there are circumstances which indefinitely extend even these proportions. I conclude, therefore, that our experience in these cases is by far too limited to furnish us with reliable data, and that any attempt to reason solely from part to the whole must prove fallacious. Another argument adduced in support of this theory is, in my opinion, equally untenable.

"It is asserted that taking the degree of elevatory force now in operation, and allowing quantity of time, the repetition of the small changes on the surface witnessed by us would produce in time results of any known magnitude, *i.e.* that the force which could elevate a district 5 feet in a century would suffice in 100,000 years to raise it 5,000 feet. This reasoning might be conclusive if we had cause to suppose that the force were uniform and constant; but even our limited experience shows this to be irregular and paroxysmal, and although the effects indicate the nature of the force, they in no way give us a measure of its degree.

"Before I proceed further I must remove two objections which have been urged against what has been called the cataclysmic theory in opposition to the uniformitarian theory, both terms in themselves objectionable from their exaggeration, as all such terms usually are. One is, that we require forces other than those which we see in operation; and the other, that it is unnecessarily sought to do by violent means that which can be equally well effected by time. It is not, however, a question we raise as to the nature of the force, but as to its energy—it is not a question of necessity one way or the other, but of interpretation; it is a question of dynamics and not of time, and we cannot accept the introduction of time in explanation of problems the real difficulties of which are thereby more often passed over than solved. Time may and must be used as without limits; there is no reason why any attempt should be made either to extend or to curtail it; but while there is no need for frugality, there is no wisdom in prodigality. After all, it will be found that whichever theory is adopted, the need will not be very different; the mountain range, for the gradual elevation of which the one will ask 100,000 years, the other may require for its more sudden elevation a force taking the same number of years to accumulate its energies.

"We must, however, judge of the past by the features it has stamped on the land,\* and these we must interpret not entirely by our own experience, not alone by our estimate of force, but by our knowledge of what amount of force the energy due to the thermal condition of the globe can develop on known dynamical

\* The evidence of facts with respect to the glacial period has already led to the admission of a greater intensity of cold; so we contend that the evidence of the past is equally definite respecting the greater intensity of energy

\* Inaugural Lecture of J. Prestwich, F.R.S., Professor of Geology in the University of Oxford. Delivered January 29. Continued from p. 292.



cal principles, and by our observation of what those forces have effected in past times.

"However we may differ in our interpretation of the present thermal state of the globe, most geologists agree in accepting the hypothesis of central heat as the one best in accordance with known facts relating to subterranean temperature, the eruption of igneous rocks, the action of metamorphism, and the crushing and contortions of rock masses. The radiation of heat into space has been accompanied by a gradual contraction of the central mass, and a shrinking of the crust, to which the trough of oceans, the elevation of continents, the protrusion of mountain chains, and the faulting of strata are to be attributed. The question is whether that contraction was accompanied by a like gradual yielding and adaptation of the solid crust to the lessening circumference of the globe; or whether the resistance of so rigid a body was only overcome by paroxysmal efforts. This latter was the view held by most of our early geologists, and is still the prevailing one abroad.

"It is not necessary to deal with the first steps of the problem. Let us take it after, for example, the readjustment of the crust, when it must have been many miles thick, which resulted in the elevation of such a mountain chain as that of the Alps; and here I must assume a point in advance. The resisting strata having given way to the tension to which they had been subjected, a state of equilibrium and repose would for a time ensue. As the secular refrigeration subsequently proceeded, the tangential force due to contraction resumed action, and while the larger areas were depressed chiefly by the action of gravity, other and smaller portions of the crust presenting the least resistance yielded, and rose at right angles to the tangential pressure.

"Now, either, if the elevatory force were limited and uniform in degree, a point would be reached at which that force was balanced by the increasing resistance and weight of the strata, and the movement would cease; or else, if the energy was a constantly generated quantity, and the rigidity such as to prevent yielding beyond a certain extent (and no solid crust can be perfectly flexible), then it would be a dynamical necessity that a time would come when, from the accumulation of that energy, it would overcome the resistance, and the opposing strata be suddenly rent and fractured. This primary resistance removed, the full power of the elevatory force would be brought to bear upon the disjointed mass, and the surplus energy expended in at once rapidly forcing forward and tilting up the now yielding strata, along the line of fracture, to that position and that height required to restore a state of equilibrium, and no more. It is not possible for any number of minor forces, where the ultimate resistance exceeds each one taken separately, to accomplish in any time, however long, that which requires for its execution a major force of infinitely greater power.

"Either a minor force, if sufficient to move a given weight, will go on moving, or else, if from any cause a further or secondary and independent resistance, such as, in this case, that dependent on the cohesion of the strata, has to be overcome, additional power must be brought to bear, which, if that secondary resistance be then overcome, the cumulated force being far in excess of the residual resistance, will be immediately expended with energy in proportion to the magnitude of the resistance mastered.

"Again, in the case of large faults traversing thick masses of strata, the conditions are nearly the same.

"The results of the foregoing conditions are in perfect accordance with observation. The enormous crumpling and folding of the strata—the vast upthrow of their disjointed edges—indicate the resistless forces which have been at work. Of these forces it is as difficult for us to realise the intensity as it is to fathom the immensity of space.

"While thus refrigeration progressed and the shell of the globe became thicker, other causes came into operation to give it greater rigidity, and so better fit it for the habitation of man.

"In the many discussions to which this question has given rise, it has been too much assumed that the shell was of uniform or nearly uniform thickness; the irregularities of the upper surface were apparent, but those possible on the under surface have been overlooked. I have, however, reason to suppose from some researches in which I have been engaged, that the under surface of the shell is ribbed and channelled in a manner and on a scale materially to influence the operation of that tidal action on which so many able and elaborate calculations have been based.

"Let us take on a continental area, having a mean surface temperature of 55° F., a point in the earth's crust through which any isotherm of depth passes, — suppose it to be that of 1,000'. This

earth-isotherm will possibly be found about a depth of about 50,000 feet. The isothermal plane must approximately follow the contours of the surface, and in mountain districts may rise some 1,000 to 4,000 feet above its other level."

Mr. Prestwich then shows that to the depth of the ocean we have to add a depth equivalent to the difference between the mean temperature of the adjacent land and that of the deep waters.

"As the position of the other earth-isotherms will in like manner occupy successive planes approximately parallel with the surface whether of land or sea-bed, it follows that, if a central molten nucleus exists, it will be divided into areas separated by boundary lines, no less important than those formed by the continental areas between the several oceanic areas on the surface; and as they are even more enclosed and isolated, their condition with regard to the possible existence of tides would approach more to that of an inland sea such as the Mediterranean, where their influence is scarcely felt. It may be a question also whether the rigidity of the earth's crust is not influenced by this mode of structure. It must certainly affect the permanence of continental and oceanic areas.

"Notwithstanding this, it may naturally be asked in view of the more constant slow changes and movements to which, in past times, the crust of the earth has been subject, and that even up to a period so geologically recent as the elevation of the Alps and the Andes, how it happens that it is now so quiescent and comparatively immovable." Mr. Prestwich showed that the hypotheses both of Mr. Hopkins and Sir W. Thomson grapple with this difficulty, and in the same connection refers to the theories of Mr. Mallet. Mr. Prestwich is not, however, satisfied with the conditions suggested by these distinguished physicists, and is led to seek for other causes to account for the present stable condition of the earth.

"The cause which suggests itself to me," he said, "is the intense cold of the glacial period through which the earth has so recently passed, and which has, as it were, anticipated the refrigeration which, in ordinary course, would have taken a longer time to effect. At present the annual variation of temperature in these latitudes extends to a depth of about 30 feet; the maximum heat of summer being felt by the end of November, and the maximum cold of winter by the beginning of June at a depth of 26 feet. But supposing the cold of winter not to alternate with summer heat, then the abstraction of heat would continue to a depth in proportion to the length of time during which the cold at the surface was maintained and the degree of that cold, and such would be the effect over a large portion of the northern hemisphere (and I believe of the southern contemporaneously) during the glacial period. For as permanent ice and snow then extended down to these latitudes, the summer sun would not sensibly affect surfaces so covered, and the abstraction of heat must have proceeded uninterruptedly. To what depth the effect may have extended has not yet been investigated, but that it must have been very considerable is evident from the depth to which the annual variations are now felt. Consequently, with a uniform permanent temperature of 32°, or lower, at the surface, and with the long duration of the glacial period, we may form some conception of how far beneath the surface the extreme cold must have extended; even now, in parts of Siberia, the ground is permanently frozen to a depth of 300 to 400 feet. Then the surface temperature in these latitudes, instead of commencing as now with a mean of 50°, and attaining 70° at a depth of 1,000 feet, commenced with a temperature of 32° F. or less, and the isothermal of 70° must have been depressed far below its present level. On the return of the present more temperate climate, that portion of the crust of the earth, measuring certainly many hundreds, and possibly some thousands of feet in depth, which had suffered from this abnormal loss of heat, would have to recover its equilibrium with existing conditions by another change in the isothermal planes, and, until that was effected, little or no loss by radiation would take place.

"Or, to look at it in another way, let us suppose periods of equal temperature before and after the glacial epoch. As the radiation of heat is in proportion to the difference of temperature between the warm body and the surrounding medium, the loss of heat by the earth would, if no colder period had intervened, have been nearly equal in equal times; but with the greater cold of the glacial epoch, the same result would be effected in a shorter time; or, what is tantamount, the loss in the same time during the glacial period would be greater than in the other two periods. Thus, supposing we take any given time of the glacial period as

producing a refrigeration of the crust equal to that which would be effected in a certain longer time of the pre-glacial or post-glacial periods, then for a certain term of time—of length bearing some proportion to the difference between the two—succeeding the glacial epoch, the earth would, with its outer crust so much below the normal, lose little or no heat by radiation, so that during that subsequent period the thermo-dynamical effects due to cooling would be reduced to a minimum or cease altogether, and a period of nearly staple equilibrium, such as now prevails, obtain.

"This last great change in the long geological record is one of so exceptional a nature that, as I have observed elsewhere,\* it deeply impresses me with the belief of great purpose and all-wise design, in stating that progressive refrigeration and contraction on which the movements of the crust of the earth depend and which has thus had imparted to it that rigidity and stability which now render it so fit and suitable for the habitation of civilised man; for, without that immobility, the slow and constantly recurring changes would, apart from the rarer and greater catastrophes, have rendered our rivers unavigable, our harbours inaccessible, our edifices insecure, our springs ever-varying, and our climates ever-changing; and while some districts might have been gradually uplifted, other whole countries must have been gradually submerged; and against this inevitable destiny no human foresight could have prevailed."

### SCIENTIFIC SERIALS

THE *Journal of Botany* for December 1874 and January and February 1875 contain quite the average of papers of general interest. Among the original papers may be mentioned in particular one on the critical species *Triticum pungens*, and another on *Rumex maximus*, by the Hon. J. Leicester Warren; descriptions of new species of Scillae and other Liliaceae, by Mr. J. G. Baker; a list of the wild flora of Kew Gardens and pleasure-grounds, by G. Nicholson; *Anthoxanthum pulch.*, by F. Townsend; and the continuation of the paper on the Botany of the Maltese Islands, by Mr. J. F. Duthie. A larger proportion of the space than usual is filled by reviews of botanical works, English and foreign. The plates include two of new species of *Asco-bolus*, to illustrate a paper by Mr. James Renny; *Anthoxanthum pulch.*, recently discovered in the south of England; and *Carex frigida* and *Salix Sadleri*, the two recent additions to the Scottish flora made by Mr. Sadler.

THE *Botanical Magazine* for February contains figures of the following plants:—*Epidendrum sringothrysus*, a handsome species from Bolivia, with large racemes of purple-red flowers, tinged with lilac. *Lilium caudense*, var. *parvum*, a very handsome miniature lily, regarded by some as a distinct species. It has small orange-red flowers spotted with purple-brown. *Veronica pinquifolia*, a shrubby species from New Zealand, with very pale blue flowers. It is hardy at Kew. *Fouquieria Selloa*, an agave-like plant from Guatemala, whose large flower-scapes were allowed to protrude through the roof of the Succulent House at Kew last summer, and must have been noticed by many of our readers. *Senecio macroglossus*, the plant with ivy-like foliage alluded to in a recent number. Lastly, a new genus, *Erythrolis*, of Commelyneae: an exceedingly pretty trailing plant from Malabar, having small leaves of a most brilliant crimson on the under surface, and small bright blue and red flowers. The species is called *Beddomei*, after Col. Beddome, its discoverer.

*Zeitschrift der Oesterreichischen Gesellschaft für Meteorologie*, Jan. 1.—On the curved tracks of cyclones issuing from the trade-wind region, by Dr. W. C. Wittner. Water resembles air in many of its movements, and is more easily observed; its eddies and currents especially may be studied with advantage in connection with cyclonic phenomena like the above-named. When a stream of water is met by another at right angles, a depression is formed at the point of interruption; particles bordering this depression sink into it in obedience to gravity, and particles at a greater distance move spirally inwards. Besides rotation there is a progressive motion of the whole eddy, in the direction of the resultant of the forces of the two streams. In turbulent streams eddies last a very short time; they are filled up almost as soon as formed. In quiet rivers, on the contrary, the whirl continues for a length of time sufficient for observation. In the development of hurricanes, difference of air-density corresponds to dif-

ference of level in water. Hurricanes, like eddies, are destroyed when the surrounding medium moves very irregularly, and we should therefore look to the neighbourhood of the tropics, where atmospheric conditions are remarkably regular, for a region favourable to their growth and progress. Near the northern boundary of the region of calms, the equatorial current begins at about S., and the polar meets it from about E., nearly at right angles, so that in this respect also the development of whirls, like those in water at the junction of rivers, is favoured. The resultant progression, towards N.W., becomes deflected as the storm advances, until, at a latitude where the eastward component of the equatorial may be supposed to vanish against the westward component of the polar wind, an excess seems to remain of the southerly over the northerly component, causing movement towards N. In still higher latitudes the more westerly equatorial and northerly polar drive the cyclone in an easterly direction. Occasionally, when the northerly component of the polar happens to be stronger than the southerly of the equatorial wind, as in the storm of Oct. 10, 1847, the system moves towards S.W. In the southern hemisphere, as in the northern, the direction of rotation indicates an irruption of the anti-trade into the trade-wind. The equatorial current, or anti-trade, appears to be the strongest both by its invasion of the trade-wind region and by the direction of advance of the consequent hurricane.

A communication from Captain Hoffmeyer, in the *Kleinere Mittheilungen*, contains valuable remarks on the relation between pressure and rainfall. In Denmark, most rain falls on the front of a minimum, and when a considerable depression is near. Like Mr. Ley, he believes that, at least in Europe, minima are formed simultaneously with heavy rains, but thinks that they are not caused by them, only magnified. He has come to the conclusion that minima must be looked upon not as results of mechanical rotation, but as functions of existing conditions and differences. They seem to him to seek and require continual nourishment. The principle of a descending current in maxima, and an ascending current in minima, broached by Mr. Buchan some years ago, he considers the only one with which we can overcome the difficulties presented by these phenomena. Air is interchanged mainly by vertical currents, resulting from thermal inequalities. Vapour also plays a large part in ascending currents. Low pressure at the earth's surface is not an indication but a cause of the *courant ascendant*. With these views, and by the comparison of weather charts, we can in general explain the main features of the atmospheric condition, though not indeed its ever-varying relations. Dr. Hann, in reply, maintains his opposition to the theory of Espy and Rey, that the *courant ascendant* is the sole or chief cause of a minimum in storms, and objects that the heaviest rains in the tropics do not in the least disturb the regular daily movement of the barometer, and to assume that the same cause in similar conditions could produce opposite effects would be illogical. Tropical rains have not been proved less extensive than those of higher latitudes, as some have supposed them to be. We have no clear evidence that condensation and rain diminish pressure. On the other hand, mechanics teach us that pressure must diminish towards the centre of a whirling mass of air. From these reasons, we should seek for an explanation in the laws of dynamics.

THE *Bulletin Mensuel de la Société d'Acclimatation de Paris* for October opens with a paper by M. S. Berthelot on "The Domestication of Animals," in which the writer expresses the opinion that the domestication of animals is due more to the art and skill of man than to their natural qualities; though the aptitude for domestication is unalterable in those animals which naturally possess it.—M. Bouillod contributes a paper on the cultivation of wild turkeys, recounting his experience in the matter, the object of which is not clear, seeing the domesticated turkey cannot be excelled in any respect.—Silkworm culture occupies its usual prominent position in the report.—The rapid growth of the *Eucalyptus globulus* is exemplified by M. Laberanne, who planted some seeds in Algeria on the 29th April, 1873, which twenty-six days later had already appeared above ground. In September, 1874, some of the plants had attained a height of 65 centimetres (26 in.).—M. Drouyn de Lhuys, in a speech on the Phylloxera, suggests that new plantations of vine from seeds should be formed, which he thinks would more easily repel the attacks of the pest.—Germany is making advances in the culture of the silkworm, which are detailed in a letter by M. A. Buvignier.

*Astronomische Nachrichten*, No. 2,020.—Mr. S. Burnham contributes a note on certain double stars.  $\alpha$  410 and H 334

\* Philosophical Transactions for 1864, p. 305.

are catalogued in identical positions, but he finds they are distinct stars, and the companion to  $\Sigma 410$  is of 19 mag. of Herschel's scale. The companion of  $\Sigma 2749$  shows an increase in distance and angle; the three stars are now almost in a line. The position of  $\Sigma 388$  appears to have increased  $100''$  since 1835.—J. Peibutt gives position observations of Coggia's Comet, together with comparison stars. J. C. Watson sends a note on his discovery of Planet (139) at Pekin.—The elements and an ephemeris of Borrelli's Comet of December 1874 are given by J. Holetschek.

COMET 1874, VI.

$T =$  Oct. 18.7391 Berlin time.

$\pi = 298^{\circ} 46' 38''$

$Q = 281^{\circ} 38' 18''$

$i = 99^{\circ} 25' 43''$

$\log. q = 9.71576.$

—Burnham notes the discovery of a close companion to  $\beta$  Leporis, dist.  $2''$ , pos.  $269^{\circ} 11'$ , 10th mag. This appears to have been missed by Herschel.—Prof. Bredichin gives differential measures of position of Juno and adjacent stars.—A number of position observations of the minor planets are given by Kowalezyk.—A lithograph of various appearances of Coggia's Comet, drawn by Vogel, accompanies this number.

## SOCIETIES AND ACADEMIES

### LONDON

Royal Society, Feb. 11.—“Some particulars of the Transit of Venus across the Sun, December 9, 1874, observed on the Himalaya Mountains, Mussoorie, at Marz-Villa Station, lat.  $30^{\circ} 28' N$ , long.  $78^{\circ} 3' E$ . Height above sea, 6,500 feet.”—Note No. I. By J. H. N. Hennessey, F.R.A.S. (Communicated by Prof. Stokes, D.C.L., Sec. R.S.)

The author observed the event with the equatorial of the Royal Society, which Capt. J. Herschel, R.E., in his absence from India, had temporarily placed at his disposal. His especial object in view was to observe the transit from a *considerable height*, and this condition was easily secured through the circumstance that he was located only fourteen miles from Mussoorie, on the Himalaya Mountains. His numerical results will be communicated very shortly in a second note. The remarks here made are restricted chiefly to what he *saw* with the equatorial.

The telescope of the equatorial has a 5-inch object-glass, with about sixty inches focal length, and is driven by an excellent clock.

The author found from actual trial that the most suitable eyepiece for both ingress (sun's altitude  $2^{\circ} 24'$  to  $7^{\circ} 29'$ ) and egress (sun's altitude about  $26^{\circ}$ ) was one of 125 power. He selected for ingress two glasses which, combined, gave a neutral or bluish field; and for egress he changed one of these for a deep-red glass, so that the field now presented a moderately deep red. The glasses were quite flat, and lay against one another in intimate contact, giving excellent definition. He enjoyed most exquisitely clear weather during his observations.

In describing the phenomena of the transit, the author has occasion to speak of Venus as she appeared *across* the sun's limb, when one portion of her own limb is seen against the sun, and the other remains against the sky. The former portion he calls Venus's sun-limb, or  $V_n$ , the latter Venus's sky-limb, or  $V_s$ . Again, he requires to mention a ring of light around  $V_n$ , which he indicates by  $L_n$ , the corresponding ring around  $V_s$  being understood by  $L_s$ . Another point is this: anyone who has watched, say the sun's limb, especially at a low altitude and with high power, must be aware of the turmoil or ebullition which there appears, very like as if the limb was being boiled. He denotes this kind of turmoil by “boiling.”

The author did not detect Venus's limb until after it had made an indentation on the sun's limb. The latter boiled sensibly, but by no means violently. It appeared jagged, and as if with minute spikes projecting inwards, all of which were well defined in the bluish field. Watching  $V_n$ , he found it also boiling slightly, but in a manner somewhat different to the sun's limb. The appearance was that of boiling vapour coming round from the face of Venus, turned towards the sun and overlapping  $V_n$ ; moreover, this boiling was not restricted to the edge of  $V_n$ , but extended  $2'$  or  $3'$  beyond, thus forming a kind of boiling annulus, in which there were minute sparkling specks dancing and

shifting about, appearing and disappearing; the edge  $V_n$  was seen through the boiling.

*Neither pear-drop nor ligament was seen either at ingress or egress.*

Col. Walker, who was at Dehra Doon, in the valley below, some ten miles south of Mr. Hennessey's position, writing to the author, states that he “saw the pear-drop and the ligament very distinctly.”

After describing his own observations, the author concludes as follows:—

1. In view of the light-ring  $L_n$ , and of the peculiar boiling annulus around  $V_n$ , which may be called  $L_n$ , I have no doubt that  $L_n$  was, in fact, a continuation of the light-ring  $L_s$ , which latter, beyond all question, was plainly visible; and under these circumstances it may be urged that Venus is surrounded by an atmosphere which at the time was made visible to the extent of  $2''$  to under  $4''$  in breadth.

2. As a matter of fact, the pear-drop or other ligament was visible at a height of 2,200 feet, but at 6,500 feet the ligament was invisible. The influence generally of height of station, from this evidence, appears undeniable; but the phenomenon still remains to be accounted for definitely. If, however, an effective atmosphere of  $x$  breadth around Venus be conceded, this atmosphere may be supposed to stop a certain amount of direct light from the sun, producing a slight shade around Venus corresponding to the breadth  $x$ . This shade would, I conceive, be quite invisible when its outer edge is backed by the sun's bright light; but could we contract the sun to a diameter equal to that of Venus *plus* twice  $x$ , and make Venus and the sun concentric, it appears likely that we should see a shaded annulus right round Venus between her limb and that of the sun. Further, that the annulus would appear darker at low than at higher altitudes, and would become invisible when the observer was raised above a sufficiency of the earth's atmosphere. Should these suggestions prove tenable, the ligament seen would break when the outer edge of the shade, corresponding to  $x$ , transited across the sun's limb.

3. Solar light shining through Venus's atmosphere, if any, produces no alteration in the lines of the solar spectrum, so far as the dispersion of a single simple prism can show. Also, Venus's face, turned towards us, reflects no light during transit, subject to the same instrumental test.

“Appendix to Note, dated November 1873, on White Lines in the Solar Spectrum,” by J. H. N. Hennessey, F.R.A.S. Communicated by Prof. Stokes, Sec.R.S.

After detection of the white lines 1658 and 1658 (Kirchhoff's scale) at Mussoorie in November 1873, I discovered two other such lines before leaving that station of observation, viz. 2009 and 2068 (about). On 28th November, 1873, I packed up the spectroscope, taking particular care that the prisms should not shift from the position they then occupied.

On 28th November, 1873, I set up the spectroscope in the Dome Observatory at Dehra, in the valley below, the prisms retaining their former position, and my recollection of the white lines seen at Mussoorie being still quite vivid. I now found that 1650 and 1658 were distinctly seen; but they were no longer nearly of the pure white colour they presented at the higher station, while what may be termed the gloss about their whiteness, which induced me to describe them as resembling “threads of white silk held in the light,” had quite disappeared; indeed they were now so decidedly greenish as not to invite attention. White line 2068 I now could hardly see, and 2009 was invisible, notwithstanding that I was quite familiar with the positions they occupied, and had made careful notes on the subject.

After this I released the prisms and turned them about variously, without producing any alteration in the white lines as they were now seen.

The height of the spectroscope above sea-level was—

At Mussoorie	...	...	...	...	7100 feet.
„ Dehra	...	...	...	...	2200 „

Anthropological Institute, Feb. 9.—Col. A. Lane Fox, F.S.A., president, in the chair.—The President exhibited a series of stone implements from the Alderley mines of Cheshire, and Dr. J. Simms exhibited five Lapp skulls.—A paper by the Rev. Wentworth Webster was read on the Basque and the Kelt, an examination of a paper by Mr. Boyd Dawkins, F.R.S., on the northern range of the Basques, in the *Fortnightly Review* of

September 1874. The author commenced by pointing out the danger of the tendency to extreme specialisation among scientific men of the present day, and proceeded to show how the "Basque problem" had suffered through that treatment. It had been taken up by pure philologists and pure anthropologists, who had viewed it only from their particular standpoints, and had too much neglected historical and archaeological researches, folk-lore, literature, drama, and, strangest of all, the physical characteristics of the present Basques. The chief aim of the paper was to show how inconclusive was the evidence of anthropology alone, and to examine Mr. Dawkins' argument. It held that, firstly, philology had demonstrated the Basque language to be agglutinative; secondly, that W. von Humboldt's conclusion is correct as to the existence of Basque names in the classical geographies and itineraries of Spain; and, thirdly, that although the identity of Basque and Iberian cannot be considered as perfectly demonstrated, its probability is very high. The special point of dispute was the conclusion of Mr. Dawkins that "the former presence of an Iberian race in Armerica is demonstrated by Dr. Broca's map of the stature and complexion of the peoples of France." The author at great length examined and analysed the maps referred to and the statistics cited in the paper, and found that the evidence from anthropology alone did not seem sufficient to support the theory combated, and all other evidence would appear to be opposed to it.—Prof. Boyd Dawkins having replied to the Rev. W. Webster's criticisms, which, in the main, appeared to him to be founded upon a misapprehension of his use of the term "Iberian," Prince L. Lucien Bonaparte remarked that the paper offered scarcely any point in which he could not cordially concur, especially where the author referred to the high competency of W. von Humboldt in respect to the Basque language and ethnology; in fact, it was impossible to dispute the superiority of that eminent philologist on that special question over every modern author not by birth a Basque. He (the Prince) maintained that it would be as presumptuous to affirm that language is always a test of race as it would be, at least, hazardous to declare that anthropologists should invariably dispense with such a test. If an unimportant minority of philologists pretend to dominate over the anthropologists, they are wrong; but the minority of anthropologists, who maintain that language should not be considered in the determination of race, are still more in error.—Rev. A. H. Sayce, as a philologist, maintained that language could not be held to be a test of race; it was a test only of social contact.—Mr. Hyde Clarke vindicated the claims of philology as a branch of anthropology and of natural science. He thought the Basque area of W. von Humboldt should be much limited. The Basque had affinities with Housa, and was thus connected with dark populations.—Mr. W. J. Van Eys remarked that Humboldt had not proved the Basques to be Iberian.—Prof. Busk, Mr. J. Rhys, Prof. Hughes, Dr. Simms, and Dr. Beddoe, also contributed to the discussion.

Geologists' Association, Feb. 5.—W. Carruthers, F.R.S., president, in the chair.—On the volcanic geology of Iceland, by W. L. Watts. Iceland is situated at the termination of the great volcanic line, skirting the extreme west of the Old World, which has existed since the Cretaceous period certainly, whilst the points of eruption appear to have travelled northwards. As all the rocks are igneous, or igneous derivatives, no stratigraphical arrangement can be made out. Basaltic lava streams are common in the vicinity of Reykjavik, though no active volcano exists in this part of the island, which is in the secondary stage of solfataras and hot springs. These solfataras are mere pits of bluish white siliceous mud, the result of the decomposition of contiguous tuff. The principal gas exhaled is sulphuretted hydrogen. Their position changes. The hot springs are working out their own destruction by the accumulation of sinter; the composition of this varies in springs within a few yards of each other. The large rifts in the old lava at Thingvall were attributed to the flowing away of the undercurrent of lava into a yet deeper depression, thus leaving the unsupported crust to sink down in the middle. All the lavas of Hekla observed by the author are basaltic, and contain crystals of felspar and olivine. An ash and cinder cone forms the summit of the mountain. There were four craters; the longest one is an elliptical depression 250 feet deep, at the bottom of which lay snow, though some ashes and clay were still quite hot. The district of Mydals Jokull, containing the terrible volcano Kotlujia, is remarkable for the confused intermixture of aqueous and igneous ejectamenta, producing agglomerates and tufas. Sand and hot water are the principal productions of Kotlujia itself, which has not been

known to produce lava, though ancient felsitic lavas were noted at its base. These floods are produced, in addition to the melting of the Jokull, by the bursting of large cavities in which water has accumulated for years. Such a reservoir was noted in a small neighbouring crater, at the bottom of which was a deep pool of turbid water, into which several small streams emptied themselves, but none ran out again. To Vatna Jokull the principal volcanic forces of Iceland seem now to have retreated. This is a vast tract of snow and ice which rests upon a nest of volcanoes, many of which have been in eruption during historical times. The Vatna rises from a series of basaltic platforms. The existence of permanently active volcanoes in the unknown interior of this mass was considered not improbable.

## EDINBURGH

Royal Society, Feb. 15.—Sir William Thomson, president, in the chair.—The following communications were read:—Obituary notice of Dr. Robert Edward Grant, late Professor of Comparative Anatomy in University College, London, by Dr. Sharpey.—An illustration of the relative rates of diffusion of salts in solution, by Prof. Crum Brown.—On the oscillation of a system of bodies with rotating portions, by Sir Wm. Thomson.—Laboratory notes, by Prof. Tait.

Meteorological Society, Feb. 10.—This was the half-yearly meeting of the Society. Mr. Milne Holme presided.—The Chairman read the report of the Council, of which the following is a summary:—The number of the Society's stations in Scotland was at present 92, and there were also 11 in other countries. The number of members was 538 ordinary, 15 corresponding, and 8 honorary members. After referring to the inquiry conducted by Dr. Arthur Mitchell and Mr. Buchan on the influence of the weather on mortality and disease, the report noticed that, on the suggestion of Mr. Thomas Stevenson, C.E., schedules had been supplied to the observatories within twenty or thirty miles of Edinburgh, so as to secure data for investigating the relation of the force of the wind to the barometric gradient. Returns had been received, but these had not yet been examined. Meteorological returns applicable to Loch Fyne for the last twenty years had been furnished by Mr. Buchan on application to the Special Commissioners appointed to inquire into the causes of the disappearance of herrings from Loch Fyne. The investigations regarding the herring fisheries on the Scottish coasts, instituted by the Society, had been continued during the past session. The Marquis of Tweeddale, who originally suggested the inquiry, had supplied the Society with twenty thermometers, to be used to ascertain the temperature of the sea at the places and at the times when the fishery was being carried on. These thermometers were by Mr. Bouverie Primrose sent to the fishery officers of the Herring Board stationed along the east coast of Scotland, and each fishery officer selected an intelligent fisherman to take the temperature of the sea where the herring shoals were found. Important results were expected from these investigations.—Dr. Arthur Mitchell read a paper on the effects of the weather of the last three months on the death-rate.—Mr. Buchan read a paper on the bearing of meteorological records on the supposed change of climate in Scotland. Mr. Buchan concludes that there has been no general tendency towards a permanent change, either as regards summer heat or winter cold.

## MANCHESTER

Literary and Philosophical Society, Jan. 26.—Edward Schunk, F.R.S., &c., president, in the chair.—A descent into Elden Hole, Derbyshire, by Rooke Pennington, LL.B. Near the road from Buxton to Castleton, and about four miles from the latter place, stands Elden Hill, in the side of which is Elden Hole, a perpendicular chasm in the rock, and, like many such apertures, reputed to be bottomless. The author describes a descent into the cavern, made by himself and others, on the 11th of September, 1873. At a distance of 180 ft. from the top a landing-place was reached, although not a very secure one, as it was inclined at an angle of about 45°. Thence a cavern ran downwards towards the south or south-east; the floor was entirely covered with loose fragments of limestone, probably extending to a considerable thickness. There was quite sufficient light at this point to enable one to sketch or read. The party then scrambled, or rather slipped, into the cavern for some few yards, during which they descended a considerable distance: it was of a tunnel-like shape; then it suddenly expanded into a magnificent hall about 100 ft. across and about 70 ft. high. The floor of this hall

sloped like the tunnel, and like it was covered with *aléris*. At the lower side they were about 60 ft. below their landing-place, and therefore about 240 ft. beneath the surface. The entire roof and walls of this cavern were covered with splendid stalagmitic deposits. From the roof were hung fine stalactites, whilst the sides were covered with almost every conceivable form of deposited carbonate of lime. In some places it was smooth and white as marble, in other places like frosted silver, whilst the rougher portions of the rock were clothed with all sorts of fantastic shapes glistening with moisture. From this cavern no opening of any length or depth was found save the one by which the party had entered it. There can be no doubt, the author believes, that this chasm has been formed by the chemical action of carbonic acid in water, and that it has attacked this particular spot either from the unusual softness of the rock originally situated there, or because there was here a joint or shrinkage in the strata. There is nothing, however, in the position of Elden Hole to lead one to suppose that any stream has ever flowed through it; no signs of such a state of things appear anywhere around. It is not related to any valley or ravine, or to any running water, and there is, as observed, an absence of any well-defined exit for water at the bottom. No mechanical action of a flowing stream can therefore have assisted the process of enlargement. The author thinks it must be due to the gradual silent solvent properties of rain-water falling on the surface, and escaping through jointings and insignificant channels in the hard rocks below. Whether the excavation took place from above or below is uncertain.—Certain lines observed in snow crystals, by Arthur W. Waters, F.G.S.

## GLASGOW

Geological Society, Jan. 14.—Mr. John Young, F.G.S., vice-president, in the chair.—Mr. D. Bell read a paper on the geology of Switzerland, embodying some observations made during a recent visit to that country.

Philosophical Society, Dec. 2.—Physical Section.—The following papers were read:—On the absence of air and water from the moon, by Mr. Francis Napier.—Experiments on fluid jets and induced currents, by Mr. Alex. Morton.

Dec. 16.—On an apparatus for testing the lubricating powers of various liquids, showing some hitherto unrecognised facts at variance with the commonly received laws of friction, by Mr. R. D. Napier.—On the effect of Loch Katrine water on various metals, by Mr. Jas. R. Napier, F.R.S.

## PARIS

Academy of Sciences, Feb. 8.—M. M. Frémy in the chair.—The following papers were read:—A remark by M. Puisseux on M. Genocchi's paper read at the last meeting with regard to the existence of the integral in equations with partial derivatives.—A letter from M. Janssen, dated Kompira-Yama (Japan), Dec. 10, 1874, describing the general results of the observations of the Transit of Venus. The first part of the letter shows that the party of observers suffered much from bad weather during their installation at Kompira-Yama, near Nagasaki. During a heavy gale one of the equatorials was completely destroyed, the telescope and micrometer broken, but their outfit was excellent, and before the day of the transit arrived they were able to repair all the damage done. Both the first outer and inner contacts, as well as the second inner one, were successfully observed, and only the last outer one missed through clouds. No black drop appeared at the sun's limb, although M. Janssen remarks that a considerable time elapsed between the moment when the first inner contact appeared geometrically perfect and the re-appearance of a fine line of sunlight beyond the disc of Venus; this M. Janssen ascribes to the planet's atmosphere.—On the general theorems of the displacement of a plane figure on its plane, by M. Chasles.—A note, accompanied by the presentation of an autograph mathematical treatise, by M. Faye.—On the magnetisation of steel rods provided with armatures, by M. J. Jamin.—A note by M. Chevreul on M. Menier's paper, read at the last meeting, on the pulverisation of manures and the best means to increase the fertility of soils.—A memoir by M. Des Cloiseaux, on the bi-refractive and characteristic optical properties of the four principal triclinic feldspars, and a process to distinguish them immediately from each other; four feldspars the author treats of are albite, oligoclase, labradorite, and anorthite.—On an easy method to determine the latitude of a place without instruments and with sufficient correctness, by M. d'Avout; the method is

based on the observations of the shadows of two points situated in a vertical at known distances, projected upon a horizontal plane, the observations being made both before and after the sun's passage through the meridian.—On the fertilisation of Basidiomycetes, by M. P. van Tieghem.—A note on M. Mendeleef's new balance, by M. Salleron.—On rolling-curved obtained by photography, by M. Huet; an ingenious process to note down permanently the curves described by ships rolling in heavy seas.—On a new electro-magnet, formed by concentric tubes separated by layers of conducting wire, by M. J. Camacho.—On the place to be given to Gymnosperms in natural classification, by M. L. Lerolle.—Several communications on Phylloxera, by MM. Lichtenstein, Boutin, Hemmerich, and others.—A note by M. C. Guérin, on an electric pile similar to Bunsen's, but in which zinc would be replaced by iron.—A note by M. G. Peyras, on the use of fumigations to combat murrains.—A letter from M. Fua, with reference to his former communications on the means to prevent explosions in coal-pits.—A note by M. Houze de l'Aulnoit, on articular immobilisation applied to the dressings of the amputated.—MM. Henry and Baillaud communicated their observations of planet (141), made at the Paris Observatory.—On the existence of integrals of any system of differential equations, by M. C. Méray.—A note on his paper, read at the last meeting, on the molecular equilibrium of a solution of chrome alum, by M. Lecoq de Boisbaudran.—On the action of hydrate of baryta upon certain mineral and organic compounds contained in beet-products, by M. P. Lagrange.—On so-called *rooty* beetroot, by M. C. Violette.—On the peripheral nervous system of marine Nematodes, by M. A. Villot.—An account of experiments made by M. Philpéau, showing that the paps extirpated from young pigs will not regenerate.—General Morin presented to the Academy a new part of the *Revue d'Artillerie*, published by order of the War Minister, and made some remarks on the contents.

## BOOKS AND PAMPHLETS RECEIVED

BRITISH.—Marsden's Numismata Orientalia: E. Thomas, F.R.S. (Trübner).—Anleitung zu Wissenschaftlichen Beobachtungen auf Reisen: Dr. G. Neumayer (Trübner).—Number: a Link between Divine Intelligence and Human: Charles Girdlestone, M.A. (Longmans).—Weinhold's Introduction to Experimental Physics. Translated and edited by Benj. Loewy, F.R.S. (Longmans).—Hereditary and Hybridism: Edward W. Cow, S.L.C. (Longmans).—The Cone and its Sections treated Geometrically: S. A. Renshaw (Hamilton, Adams, and Co).—Statistical Society Almanack for 1875 (E. Stanford).—Animal Physiology; the Structure and Functions of the Human Body: John Cleland, M.D., F.R.S. (Wm. Collins).—Physical Geography: John Young, M.D., J.R.C.S. (Edin.), F.G.S., F.R.S.E. (Wm. Collins).—Proceedings of the Literary and Philosophical Society of Liverpool.—Six Months among the Palm Groves, Coral Reefs, and Volcanoes of the Sandwich Islands: Isabella L. Bird (Murray).—Humboldt's Natur- und Reisebilder: C. A. Buchheim, Ph.D., F.R.C.P. (F. Norgate).—An Introduction to Human Anatomy, including the Anatomy of the Tissues: Wm. Turner, M.B. (A. and C. Black).—Lessons in Elementary Mechanics: Philip Magnus, B.Sc., B.A. (Longmans).—Fungi: their Nature, Influence, and Uses: M. C. Cooke, M.A., LL.D. Edited by the Rev. M. J. Berkeley, M.A., F.L.S. (Henry S. King and Co.)

## CONTENTS

PAGE

THE LOAN COLLECTION OF SCIENTIFIC INSTRUMENTS . . . . .	301
CAVE-HUNTING ( <i>With Illustration</i> ) . . . . .	302
OUR BOOK SHELF . . . . .	303
Darwin's "Descent of Man" . . . . .	305
Newton's "Zooology" . . . . .	305
LETTERS TO THE EDITOR:—	
MARINE BOULDER CLAY, and other Deposits.—Principal J. W. Dawson, F.R.S. . . . .	306
The Transit of Venus.—E. W. PRINGLE ( <i>With Illustration</i> ) . . . . .	306
ANTS AND BEES.—ALFRED GEORGE RENSCHAW . . . . .	306
ON THE VALUE OF THE SO-CALLED CHAMELEON BAROMETER as an Hygro-meter.—A. PESCE SMITH . . . . .	307
PHOSPHORUS AND CARBON DISULPHIDE.—CHAS. T. WHITSELL . . . . .	307
THE MICROGRAPHICAL DICTIONARY.—POLLEN GRAINS.—M. C. COOKE . . . . .	307
OUR ASTRONOMICAL COLUMN:—	
VARIABLE STARS . . . . .	308
Occultation of Antares . . . . .	308
ENCKE'S COMET . . . . .	308
WINNECKE'S COMET . . . . .	308
MR. HAMILTON'S STRING ORGAN. By Lord RAYLEIGH, F.R.S. . . . .	308
ICE PHENOMENA IN THE LAKE DISTRICT. By J. CLIFTON WARD ( <i>With Illustrations</i> ) . . . . .	309
SCIENCE AT BANBURY . . . . .	310
THE EDINBURGH BOTANICAL SOCIETY . . . . .	311
THE RECENT STORMS IN THE ATLANTIC. By W. DE FONVILLE . . . . .	312
NOTES . . . . .	312
THE PAST AND FUTURE WORK OF GEOLOGY, II. By Prof. PRESTWICH, F.R.S. . . . .	312
SCIENTIFIC SERIALS . . . . .	317
SOCIETIES AND ACADEMIES . . . . .	318
BOOKS AND PAMPHLETS RECEIVED . . . . .	320

THURSDAY, FEBRUARY 25, 1875

A GERMAN MANUAL OF SCIENTIFIC  
INQUIRY

*Anleitung zu wissenschaftlichen Beobachtungen auf Reisen mit besonderer Rücksicht auf die Bedürfnisse der Kaiserlichen Marine.* Edited by Dr. G. Neumayer. (Berlin, Oppenheim; London, Triibner, 1875.)

IN estimating the merits of a work like this German Manual, we must bear in mind that ordinary treatises are not what a traveller asks for. These are primarily written for the use of students, not for that of investigators, and the stand-points of the student and of the investigator are wholly different. The student takes a position in the very heart of the great continent of established knowledge, and his aim is to familiarise himself with what is already known, but the investigator places himself on the frontier of that continent, and is always directing his thoughts into the illimitable regions of the unknown. It is therefore obvious that the books needed by a traveller must be composed in a different spirit to those intended for students. They must summarise, so far as possible in the small space that is available, the most advanced knowledge of the several sciences; they must dwell at length upon what is *not* known, and they must explain how processes, commonly carried on at a table, with abundant appliances, may be undertaken in the open air, amid the manifold discomforts of a journey and in the isolation to which every traveller is necessarily obliged to submit. The satisfactory combination of these three requirements is hard to accomplish, while it is scarcely possible for anyone who has not himself been a traveller to do justice to the last of them.

Dr. Neumayer informs us that the present work, of which he is the editor and to which he has himself contributed an important and well-illustrated memoir on Hydrography, took its origin in a meeting of scientific men at Berlin. They recognised the merits of the English "Admiralty Manual of Scientific Inquiry," which appears to be much appreciated by German navigators, but they felt that a more elaborate work might advantageously be supplied, having special reference to German culture and needs. The result of the conference has been the production of this volume. It contains contributions from twenty-eight men, all experts in what they write about, many of them of the highest distinction, and many of them travellers. It is therefore impossible but that such a compendium should be of sterling worth. Unfortunately it is equally impossible for us, in a short review of so encyclopædic an undertaking, to give more than a partial idea of it.

The authors, as we might expect, have treated their subjects in very different ways, so that there is much individuality in their writings, and perhaps some disproportion in the spaces allotted to the several subjects. Again, some of the best memoirs are on topics where one would have least hoped to meet with interesting matter; thus, Dr. A. Meitzin has drawn up an exceedingly instructive memoir on Political Geography and Statistics, and Dr. Friedel one on Medical Science. There is a masterly and original treatise by Dr. Koner on the

unexplored parts of the world and on geographical features generally; and Kieppert contributes an article on Flying Surveys. Von Richthoven, of Chinese celebrity, writes a memoir on Geology, throughout which the special turn of mind of an accomplished traveller is conspicuous; and the African explorer, Schweinfurth, gives one on the collection and preservation of plants; while Dr. Günther, of the British Museum, writes upon reptiles and fish. In short, all the branches of zoology and botany are excellently represented. Dr. Steinthal has contributed a very instructive paper on linguistic inquiry, showing, among other things, the sort of conversation that a traveller should encourage in order to procure synonyms and nice distinctions of words; also to obtain correct ideas of construction. Thus he has pages of such words or phrases as these: "The sky; clouds; the sky is clear, is cloudy. Wind, the wind blows; storm; whirlwind. The sun is risen, is set, burns hotly. The moon, new moon; there is no moon; stars; comet; meteor," &c. This ought to afford an excellent guide to persons desirous of compiling vocabularies of hitherto unwritten languages. The only paper to which exception might be taken is that on fixing geographical positions; for, however sound it may be, it is written from the point of view of a University professor, and omits the matters connected with the carriage and manipulation of instruments under the difficulties inseparable from rough travel, which are precisely those about which the traveller most needs information.

The volume contains almost seven hundred pages, large octavo, in a rather small but readable type. Thanks to its being issued on paper that is neither thick nor heavy, it forms by no means an unwieldy book. There can be no doubt that it will become a standard work for all travellers who can read German. It wants an index, because, although it is divided into twenty-eight sections, it is by no means easy to hunt out a required passage, especially as the memoirs necessarily encroach upon the provinces of one another; if the book be translated into English, this want ought to be supplied. Again, it is only to some of the memoirs that a list of special works of reference is appended. These lists are extremely useful to persons preparing for a journey, and all the memoirs should have been furnished with them. If such lists should ever be compiled, and if the works to which they refer were freely added to the libraries in the capitals of the various colonies, they would be of the greatest assistance to travellers, temporarily resident, while completing their preparations for a start, or in putting their materials into order in the interval between two journeys.

In concluding these remarks, attention may serviceably be directed to a desideratum, not only of scientific travellers, but of all who, having been well grounded in science, occupy themselves occasionally in scientific research; namely, a book that shall contain the principal constants and formulæ of every branch of science, each accompanied by a short reminder, as it were, of the method by which it was obtained. Such a book, suitable to the state of knowledge at the bygone time when it was written, is actually in existence, namely, Carr's "Synopsis" (published by Weld). The condensation, elegance, and precision of its style are worthy of the highest commendation. It was a *vade mecum* of the late Mr. Babbage, to

whom the writer of these lines was first indebted for a knowledge of its existence, but it is now out of date. It is sincerely to be desired that a band of scientific professors to whom the necessary formulæ are familiar would be disposed to co-operate in producing a work similar to Carr's "Synopsis," but extended to all branches of science, and in accordance with the most advanced state of knowledge of the day. F. G.

#### THE SANDWICH ISLANDS

*The Hawaiian Archipelago.* Six Months among the Palm Groves, Coral Reefs, and Volcanoes of the Sandwich Islands. By Isabella J. Bird. With Illustrations. (London: John Murray, 1875.)

WE fear there are few who have any definite idea of the situation of the Sandwich Islands, or indeed of any of the other numerous groups that bestar the blue Pacific.

The Sandwich Islands lie upwards of 2,000 miles southwest of San Francisco, and consist of fifteen islands, of which only eight appear to be inhabited, viz., Hawaii, Maui, Lanai, Kahoolawe, Molokai, Oahu, Kauai, and Niihau. The total area is about 7,000 square miles, and the native population is under 50,000. There are besides upwards of 5,000 foreigners, the Chinese being more largely represented than any other nation, Americans and British coming next. There is, however, a large native white population, descendants of American missionaries and others who settled in the islands years ago; most of the Government offices—for the Sandwich group has a Constitutional Monarchy—being filled by whites of this class. The islands have for many years been professedly Christian in religion. They extend from  $18^{\circ} 50'$  to  $22^{\circ} 20'$  N. lat., and from  $154^{\circ} 53'$  to  $160^{\circ} 15'$  W. long. Their official designation is the "Hawaiian Islands." "Their climate for salubrity and general qua-



FIG. 1.—A Night Scene in the Crater of the Volcano of Kilauca, Hawaii.

bility is reputed the finest on earth. It is almost absolutely equable, and a man may take his choice between broiling all the year round on the sea level on the leeward side of the islands at a temperature of  $80^{\circ}$ , and enjoying the charms of a fireside at an altitude where there is frost every night of the year. There is no sickly season, and there are no diseases of locality. The trade winds blow for nine months of the year, and on the windward coasts there is an abundance of rain, and a perennial luxuriance of vegetation."

So says Miss Bird, whose delightful book we recommend to all who wish for a full and graphic account of the present condition of the Sandwich Islands and islanders. She spent seven months of the year 1873 on the islands for the sake of her health, rode and sailed

and climbed about fearlessly everywhere, using her eyes to the very best advantage. The result is, that in less than 500 pages she gives a panoramic picture of the various phases of nature and life in the Sandwich Islands, which leaves little to be desired.

The largest of the islands is Hawaii—its area is 4,000 square miles—but the capital, Honolulu, the headquarters of one of our Transit expeditions, is on Oahu. Hawaii Miss Bird calls a huge slag, and the same, we fancy, may be said of most of the other islands; everywhere there are unmistakable signs of the fiercest volcanic outbursts, and every now and again are the inhabitants reminded of the instability of the foundations of their lovely dwelling-place. Nevertheless, nobody in Hawaii troubles himself with the thought



of the terrible possibilities that may at any moment happen. Natives and foreign residents appear to resign themselves unreservedly to the perpetual "afternoon" influence of the land, where there seems to be little need of "taking thought for the morrow."

Miss Bird gives us many glimpses of the luxuriant vegetation which is to be found almost everywhere on the lower slopes of the islands; a mere list of the various trees to be met with would occupy more space than we can afford. Almost all the roots and fruits of the torrid and temperate zones can be grown on the islands, though the *flora* is far scantier than that of the South Sea groups. The indigenous fauna is small, consisting only of hogs, dogs, goats, and an anomalous bat that flies by day. There are few insects except such as have been imported, and there is no great variety of bird-life.

In Hawaii, as well as in others of the islands, the coast line is everywhere broken by deep "gulches" or ravines, often from 1,000 to 2,000 feet in depth, running for miles into the interior, clothed from top to bottom of their nearly perpendicular sides with almost impenetrable vegetation, and having the narrow valleys below raked by torrent-like rivers, which are often swollen to many hundred yards in breadth.

No doubt the principal attraction to the scientific reader in Miss Bird's narrative will be her account of the visits which she was brave and determined enough to make to the volcanoes, active and extinct, on Hawaii and Maui. All the principal islands of the group, being of volcanic origin, are more or less mountainous, ranging in extreme height from 400 ft. in Kahoolawe to close on 14,000 in Hawaii, the loftiest island in Oceania. As our readers,



FIG. 2.—The Mountain Mauna Kea from Hilo.

no doubt, know, there are on the island of Hawaii two active and at least two extinct volcanoes; indeed, almost everywhere in the interior evidence of former volcanic action is to be met with. "To the south of the Waimea plains violent volcanic action is everywhere apparent, not only in tufa cones, but in tracts of ashes, scoriae, and volcanic sand."

Mauna Loa, somewhat to the south of the centre of the island of Hawaii, is the highest active volcano in the world, rising to a height of 13,760 feet. The whole of the south side of Hawaii, down to and below the water's edge, is composed of its slopes, its base being 180 miles in circumference. "Its whole bulk above a height of 8,000 feet is one frightful desert," though vegetation, in the form of grey lichens, a little withered grass, and a hardy asplenium, extends 2,000 feet further up. During Miss Bird's visit to the summit, the thermometer regis-

tered 11° of frost. The crater Mokuaweoweo, is six miles in circumference, 11,000 feet long, 8,000 feet wide, with precipitous sides 800 feet deep. The crater appears to be in a state of constant activity, and at times overflows, carrying destruction to the lowest levels of the island. Miss Bird tells us that since white men inhabited the islands there have been ten eruptions from Mauna Loa. Of the condition of the crater, the following description, by Miss Bird, of what she saw on her visit, accomplished amid hardships that few men would care to undergo, will give the reader a vivid idea:—

"When the sun had set, and the brief red glow of the tropics had vanished, a new world came into being, and wonder after wonder flashed forth from the previously lifeless crater. Everywhere through its vast expanse appeared glints of fire—fires bright and steady, burning in rows like blast furnaces; fires lone and isolated, un-

winking like planets, or twinkling like stars; rows of little fires marking the margin of the lowest level of the crater; fire molten in deep *crevasses*; fire in wavy lines; fire, calm, stationary, and restful: an incandescent lake two miles in length beneath a deceptive crust of darkness, and whose depth one dare not fathom even in thought. Broad in the glare, giving light enough to read by at a distance of three-quarters of a mile, making the moon look as blue as an ordinary English sky, its golden gleam changed to a vivid rose-colour, lighting up the whole of the vast precipices of that part of the crater with a rosy red, bringing out every detail here, throwing cliffs and heights into huge black masses there, rising, falling, never intermitting, leaping in lofty jets with glorious shapes like wheatsheafs, corruscating, reddening, the most glorious thing beneath the moon was the fire-fountain of Mokuaweeweo.\*

On the east flank of Mauna Loa, about 4,000 feet in height, is the crater of Kilauea, which, Miss Bird says, has the appearance of a great pit on a rolling plain.

"But such a pit! It is nine miles in circumference, and its lowest area, which not long ago fell about 300 feet, just as ice on a pond falls when the water below it is withdrawn, covers six square miles. The depth of the crater varies from 800 to 1,100 feet in different years, according as the molten sea below is at flood or ebb."

We wish we had space to quote Miss Bird's fearfully vivid description of what she saw during the two visits she made to Kilauea, descriptions which, were they not evidently written on the spot with a truthful pen, would almost deserve to be called sensational.

She also made the ascent of Mauna Kea, to the north of Mauna Loa, the highest peak in Oceania, perpetually covered with snow, a dead volcano, whose top consists of deep soft ashes and sand.

On the west side of Hawaii is another extinct volcano, Hualulai, 10,000 feet high, which has only slept since 1801, when there was a tremendous eruption from it, which flooded several villages, destroyed many plantations and fish-ponds, filled up a deep bay twenty miles in extent, and formed the present coast.

The largest extinct volcano in the world, Haleakala, is in the centre of the island of Maui, lying to the north-west of Hawaii. It is 10,300 feet in height; its terminal crater is nineteen miles in circumference, 2,000 feet deep, and contains numerous subsidiary cones, some of which are 800 feet high. Miss Bird of course visited it, and, as usual, her description is exceedingly graphic and full, and is considerably helped out by an excellent map of the crater. It seems that very few of the usual volcanic products are present in this extinct crater.\*

Volcanic action in the Sandwich Islands would seem to have died out from west to east; this is inferred from the state of the lava and the great depth of soil in some of the western islands, as in Oahu and Kauai, the latter the most westerly of the inhabited islands. Some very remarkable instances of the powerful effects of weathering in causing degradation are to be seen in this island. The Punchbowl, a crater behind Honolulu, was in 1786 observed to be composed of high peaks; but atmospheric influences have reduced it to the appearance of a single wasting tufa cone; and the cone of Diamond Hill, to the

south of the town, is also, from the same causes, rapidly diminishing.

The native population of the Sandwich Islands, which belongs to the Malay or Malyo-Polynesian division of Oceania, is fast dying out, at the fearful rate of something like 1,000 per year; so that unless some counteracting circumstances intervene, it must in a very few years become entirely extinct. Cook calculated the population of the islands in 1778 to be about 400,000; now the native population is under 50,000. That the decay is to a considerable extent owing to contact with whites there is no doubt.

But when every allowance is made for the effects of such contact upon the native population, it is questionable whether this will account completely for its rapid decrease. A similar decrease seems to be going on all over the Pacific islands, even in places where the whites have always been extremely few. From this point of view M. Leborgne has recently turned his attention to the small Gambier group, which consists of four islands. Magaréva, the most important island, had in 1840 a population of 1,130; it is now only 650. Dr. Hamy, in an article in *La Nature*, ascribes the prevalent diseases mainly to consanguineous marriages, a cause which is likely to obtain in many of the other isolated Pacific groups. This may have something to do with the diminution of the Hawaiian population, as also the fact that the careless, happy, and extremely sociable people seem to be almost devoid of anything like parental affection, taking little care of their children, and readily parting with them to anyone willing to take them; and the consequence is that a large proportion die in infancy. Another point to be noted is that in 1872 the males exceeded the females by 6,400 souls.

At all events there is no doubt that the populations of most of the Pacific islands are rapidly disappearing, and that ere very long the only tenant of their lovely homes will be the omnipresent white man, who has foisted on them an exotic civilisation which seems to have unmanned them, to have completely checked their natural development, and whose invariable concomitants have been disease and widespread destruction.

We again recommend Miss Bird's most attractive book to the favourable notice of our readers. A small map of the islands is prefixed, and the few illustrations are beautifully executed.

#### OUR BOOK SHELF

*Sun and Earth as Great Forces in Chemistry.* By Thos. W. Hall, M.D. (London: Trübner and Co.)

THE author of this work, professing himself the preacher of a new doctrine, theorises, to use his own words, "on the phenomena of chemistry . . . considering the whole of chemistry as but heat acting on matter." The sun is considered to exert some subtle chemical influence on matter, but, unfortunately for science, these effects, we are told, cannot be studied experimentally, "yet we can do so theoretically to a very useful extent." After carefully perusing the twelve chapters in which this eminently theoretical treatment is carried out, we are driven to ask ourselves whether Dr. Hall's views are not more of the nature of complication than of explanation. It may be safely affirmed that the phenomena of chemistry are far more easily explained by existing theories—imperfect though they be—than by the obscure reasoning based on perfectly gratuitous assumptions in which the present

\* According to Mr. Brigham, the products of the Hawaiian volcanoes are native sulphur, pyrites, salt, sal ammoniac, hydrochloric acid, hematite, sulphurous acid, sulphuric acid, quartz, crystals, palagonite, feldspar, chrysolite, Thompsonite, gypsum, solfatarite, copperas, nitre, arragonite, Labradorite, limonite.

volume abounds. Neither is the work free from the grave charge of inaccuracy. The writer who speaks of the sun as an "everlasting, universal, equable heat source," cannot be acquainted with Sir Wm. Thomson's paper on the dissipation of energy. On page 37 the equivalent of iodine is stated to be 125; on page 46 we are told that potassium is negative to sulphur. It will be new to our readers to learn (p. 50) that "attraction in chemistry does not differ from that in physics," and that carbon disulphide is prepared (p. 52) by powdering, mixing, and heating carbon with sulphur. On page 108 we are informed that "latent heat is, by the study of galvanism, resolvable into electricity." We do not differ from Dr. Hall in considering the following idea of the cause of electro-magnetism as "most rudimentary and rough." Speaking of a solenoid, the author states (p. 116), "Such a solenoid or its latent-heat current will avoid the latently hot parts of the earth—that is, her equator—and will place itself at right angles to the equator—that is, move away from the equator as far as it can; will, in fact, assume a position parallel to the magnetic meridian of the place, &c." The phraseology adopted by Dr. Hall must be characterised as eminently original; we select a few expressions to submit to the judgment of our readers:—"Proto-metallisations," "nitridations," "hydro-soluble," "tensified, unomorphigenic electroid," "disoccupied," "very unnegative hydrogen," "hydrohalogenic acid," "equo-terro-solar equilibrium," "protometalloid," "dis-equilibrium." The description of the combustion of carbon is perhaps worth quoting entire:—"Carbon combines with oxygen, leaves its solid shape for a gaseous one, forming carbonic anhydrid gas, and this greatly because of carbon's own heat constitution; and, further, because of the intense nearness of the oxygen to carbon and our earth's comparative distance; this because also of the excellent heat capacity of oxygen itself: and thus carbon with oxygen leaps up into carbonic anhydrid gas, earth loosened into the highest sun forms, approaching that of oxygen itself, for the heat capacities of carbon are near those of oxygen: but the oxy-terric struggle for carbon is arduous; our earth has greatly in her favour her immensity, but then she is far off, and her forces decrease with distance; but even so, for freeing carbon from our earth's control, oxygen requires always, as we know, the further assistance of heat on carbon; we always, for oxy-carbonic combination, have to set fire to carbon." On p. 34 we are gravely informed that potassium, even under naphtha, is acted upon by sun and earth forces, and becomes covered with an "allotropic crust." The author then goes on to remark that this behaviour arises from the fact that free potassium is "not a child of nature or of our sun, but of furnace heat, and its equilibrium taken with furnace heat must become slowly changed to that of our sun." In the new theory a metallic protoxide is thus formulised:  $E, M_1O$ , "in which E stands for our negative earth, and x for the part she takes in the action not quantitatively known"—we may venture to add, nor yet qualitatively. It would be as tedious as unnecessary to give further quotations in illustration of the manner in which Dr. Hall has handled his subject—the extracts given above will doubtless serve as a caution to readers intending to take up the book. The selections themselves will render further comment a work of supererogation.

#### LETTERS TO THE EDITOR

[The Editor does not hold himself responsible for opinions expressed by his correspondents. Neither can he undertake to return, or to correspond with the writers of, rejected manuscripts. No notice is taken of anonymous communications.]

#### On the Building up of the Tone in the "Gamba" Organ-pipe

IN considering the nature of this pipe, and in determining the relation of its air-reed and its air-column, one fact discovered in

these investigations should always be borne in mind, that the pitch of the reed is dependent not on vibrating length, but on vibrating divergence—on the amplitude of the reed's motion. The pitch of the air-column is not necessarily the same as the pitch of the air-reed; they may be and often are at variance: and this pipe will afford a happy means of demonstration of the statement made in a previous letter, that the tone of every organ-pipe is dual. As regards the reed, whatever the modifications of length by height of mouth, of thickness by varied wind-way, or of strength by amount of wind-pressure, the final result is bound by this law of divergence. In the typical air-reed, any deviation from the direct line of force taken by the stream of air is the beginning of vibration; its highest possible rate of vibration begins existence on its least divergence from the direct line; consequently, its highest pitch is its inceptive tone at this stage or condition of untamed energy. The bass has always been considered the basis and commencement of musical tone; every relation of tones has been examined on that ground, and it has undoubtedly been the source of many errors, one might almost say in the nature of superstitions, so tenacious has been its hold, so blinding its influence on the perceptions. Tone has its beginnings in the highest activity, and descends to the lowest and slowest; the development of its mechanical relations proceeds by definite degrees, and the issue depends on the affinity existing between the pipe and the reed, both possessing definite form, power, and character, and blending these by law. The vibration of the aeroplastic reed is thus shown to be *isotonic, not isochronous*; the laws of its vibrations are identical with those of the things most like itself, of sound-waves, of light-waves.

It was my good fortune some time ago to have placed in my hands a specimen of a variety of "Gamba" devised by the famous organ-builder, Schulze, of Paulenzelle. The "Gambas" form a class of pipes variously constructed in scale, and they are so called from the quality of their tone imitating the old "Viol da Gamba" and its modern representative the "violinello." The general characteristics of the class are—cylindrical pipe of comparatively slender scale, low-cut mouth, full-winded at foot, and slow in speaking; the slow speech is a necessity, and is caused by the wind being, as it is technically termed, "much thrown out" that is, the line of force of the current of wind is set more outward than ordinarily, for without such arrangement the fundamental or ground tone of the pipe would not secure its hold; some harmonic would usurp possession; for the air-reed, being short in consequence of low mouth, and strong from excess of wind, would keep to harmonics as the "flute harmonique" does; the latter has a low languid (or interior level within the mouth), the "Gamba" has a higher languid in relation to the under lip, thus directing the stream at a more oblique angle to that level. The tone has decided introductory and transitive harmonics. Of their sequence, although but momentary, the ear conveys a clear impression to our consciousness. We call it a "stringy quality," and it is a very interesting inquiry how this peculiar pipe-tone is built up. The characteristic quality pertaining to all stringed instruments whose tone is elicited by the bow, does, we may well suppose, arise through a process bearing a close analogy to this.

It is a disadvantage, this slow speech of the "Gamba," often felt to be excessively slow. Most skilful voicing is needful to give sufficient time for the appearance of the introductory harmonics without too greatly delaying the fundamental, for it is a nice point to strike the mean between having the wind so much thrown out that the pipe will not speak any tone, and risking, by giving quicker speech, the sudden "flying off to the octave," with obstinate persistence not to descend.

Take note of this. If you hold your hand or your finger near the mouth of any speaking organ-pipe, there is forthwith a sensible flattening of its pitch, deepening with the nearer approach of the hand; in tuning organs it is the ordinary custom to test pitch by this simple method, determining thereby whether the pipe will best bear flattening for its nearer approximation to a desired pitch or concord with others. Suppose yourself to be tuning a set of "Gamba" pipes: you would notice perchance that a restive pipe continually darting off to harmonics would be corrected and steadily held in check so long as your hand or finger was near or across its mouth. We can thus well understand how it might occur to Schulze that the temporary expedient could be made permanent. This is what Schulze did: he fixed a small bar across the mouth. The device proved successful. In pipes thus treated the tendency of the reed to settle at the octave is suppressed, speech is quickened, more wind may be given without danger, and the quality becomes in coun-

sequence more characteristic, more "stringy." Schulze has extended his method to large pedal pipes, producing a stop of remarkable beauty, called the "Violine."

Applying the air-reed theory to this Schulze's "Gamba," we shall see how fruitful it is in illustration of the actual process of tone-making. Without diagrams and with but few technical terms it may be made clear and comprehensible. Let us take a specimen-pipe. It is of slender, graceful proportions, what is called "narrow scale," length thirty-seven inches and a quarter, diameter one inch and five-eighths, mouth or *embouchure* in breadth one inch and a quarter, and three-eighths of an inch high, and its pitch answers to the note E in the tenor octave. It has a very fine wind-way, large foot-hole, and is considerably overblown, for it will bear it. There is a bar in front of the mouth, fixed upon the little upright strips projecting at the sides about a quarter of an inch, which are termed ears; they are common to pipes until the size is too small to require it. Builders say the ears are added to pipes to steady the tone. On the theory advanced in these papers, we find their purpose is to prevent any flank movement of the atmosphere during the vibration of our air-reed, for the angle formed by the vertical line of the mouth and the line of force of the outwardly inclined stream of air presents an opening of weakness, and these ears are as ridges or outworks thrown up to guard against any premature invasion by the external air which, as intimated in an earlier letter, pierces through at the proper time, only, just, under the edge of the upper lip.

We readily perceive that the "Gamba" pipe has three specialties: overblown wind, to give a stiffer reed; a low-cut mouth, as a provision for shortness of reed; and wind much thrown out as a means compulsory for ensuring a greater amplitude in the reed's motion,—the result of the combination being that the tone is rich in harmonics; harmonics precede the ground-tone, and follow it, and coalesce into it, and linger behind as though the last to quit the pipe. There is nothing more beautiful in all the varied wealth of an organ than a well-voiced "Gamba." Every tone suggests a symphony, many-tinted, autumnal. There is another remarkable feature peculiar to these—the artist can shade them with less depth of ground-tone and more varied and delicate hues in the harmonics, which nevertheless come out more brightly in the contrast, and compensate the ear with a new variety, toned with less body yet with equal fullness, through the heightening of the harmonic colour, and the more gradual blending of the whole.

In the pipe we are examining we shall find that the wind is not so much thrown out as in the older class of the species, and herein lies the real meaning of the difference, for by the agency of the bar an equal amplitude is enforced in the air-reed, but one of new form: and see how gracefully it is drawn,—yes, happily we can see, for the new form bears an impress highly significant. A little bit of paper deftly applied will enable us to watch the process of nature. Take away the bar, and the pipe will not sound its ground-tone—it is only able to produce its string of brilliant harmonics. Look at the air-reed: how minute a space it traverses whilst these high notes are thrilling in your ears.

In substitute for the removed bar, now lay a small pencil across the mouth, and see how in coy consent the air-reed yields, comes out to you with a fine curve, and all the power of the pipe is affirmed coincidentally with this visibly extended amplitude of the reed's motion. You can change it from one state to the other by this movable bar, and you have to notice that the reed is almost upright in stem, but bends over, arching at the tip,—notice also that the inward curve of the reed is less than the outward curve. The explanation of this influence will be quickly divined if you fully comprehend the way in which the reed builds itself up in a curve, leaning outward upon the external air: the air composing the reed issues from the wind-way in a dense stream; the particles are most compressed at the root, and gradually expand and become less energetic as they reach higher freedom—the velocity of the upward stream motion attracts the external air with force, strongly, to the root, bearing with lessened force on the less compressed portions higher up, and the gradation of force so manifested gives rise to the curve—the curve delineates the force, we may say this curve expresses the constant flow of the surrounding air to this diversified region of "least pressure," its impulses being in graduated power from root to tip. By the bar we interfere with the direction of this flow, concentrate it more on the lower portion of the stem, and shield the tip of the reed from its influence; the upper portion, having thus lost so much of its natural support, is bent by the outflowing nodal wave of the pipe in a more supple curve, and to an extent

equal to the required amplitude for its pitch. The form differs now. The curve of the "Gamba" is not the same as the curve of the "diapason."

The distinct agency of the air-reed and the nature of the air-column in relation therewith being evident, the inference follows that the note produced is dual, consists of two unisonous notes blended into one sound. Quite unexpectedly the chosen pipe furnished me with the talisman to prove its truth. "When the reed and the pipe are suitably mated, the union is one of perfect harmony; but the reed rules always: it may be sharp to the pipe, but the pipe can never be sharp to the reed, for on the first intimation of such the reed is roused, and starts forth to a tone of higher velocity. How slight a matter may derange the union of the reed and pipe. If we tease the pipe with this pencil, peace is disturbed. Our beautiful little "Gamba" is very sensitive and high-spirited, and cannot help letting us hear a little of the inner life of the home when things go a trifle wrong. There is one particular place across the mouth for the fixture of the bar: if, resting the pencil at the upper points of the projecting ears, you leisurely bring it down, you will hear the changing harmonics; then, halting just a hair's breadth or so before the true position is arrived at, all tone will be lost, and there will suddenly break forth a wailing "who-hoo, who-hoo;" that torture will continue until you relieve the suspense by moving the pencil another shade in descent, when the discord will resolve into the perfect tone, instantaneously, as two dew-drops when they touch melt into one. Precisely the same "who-hoo" as we hear when tuning two separate diapason pipes so nearly in tune that they are only a shade out of unison and just on the point of accord. The "Gamba" pipe and the reed were similarly at variance; the air-reed, not having quite yielded to the outward influence of the bar, was a trifle sharp to the pipe; the super-nodal wave was too short and unable to effect a synchronisation with precision, and therefore the phenomenon of beats was manifested. We could have lengthened the super-nodal wave and flattened the note by adding a portion to the top of the pipe, when concord would have followed, as it did by lowering the bar, for in tuning it matters not which note of two is altered to bring about unison; we might alter either pitch of pipe or pitch of reed; but by the lowering of the bar we flatten the reed, and cause thereby the descent of the node (then an uneasy fulcrum) and the lengthening relatively of the super-nodal column. As a listener remarked "there was surely a fight going on inside," we settled it by favouritism, taking sides with the little "Gamba," and gaining the reed over in concession of its strength for the sake of concord. That is the explanation as it suggests itself to me, practically, exhibiting how a strong reed drives the node higher up in the pipe, and a weak reed favours the opposite; thus determining the variations in the lengths of pipes of unisonous pitch, so long an unsolved problem.

Another point of some importance is also illustrated—that the earliest harmonics in the theoretical series may be out of tune with the fundamental. Here the introductory or transitive harmonics are, it is evident, all sharp to the ground tone, since the influence of the bar does not come into effect until its flattening power ushers in the fundamental; phenomena of this kind occur in other instruments mostly unacknowledged—it is admitted to be the case in the trumpet, which has No. 5 in the series flat, 7 still flatter, and 9 sharp. A diapason pipe will, however, exhibit the same in the small pipes of the higher octave; they may be blown to imitate exactly the clash of the trumpet.

As showing the essential nature of the curve of the reed under the influence of the bar, it is worth notice that in the earlier "Violine" stops thus treated a square-faced bar was fitted, but with not so good effect as when the rounded bar was adopted; and in the light of our explanation we see why it should be so, for the curve could not form itself truly. The best form of bar is that given by a split pencil, the half-round, with the flat surface outward. Many other points of interest will be dealt with in another letter, on the interior movements of vibrating air-columns.

The study of the organ-pipe in every mood of its behaviour will make untenable the elegant fancy of a promiscuous assemblage of pulses fluttering and clamouring at the lip of the pipe, one of which out of a thousand it selects. It is a fair-seeming explanation, and under the commanding name of Prof. Tyndall generally accepted, for nothing better had been devised in philosophy. Not too strictly interpreting an idealogy of expression, there yet remains an implied theory which is not in any sense borne out by the teachings of experience. The artist has some prescience of the powers that are to work his will; in practice

there is nothing adventitious; the pipe is a mechanism designed to a precise end which it fulfils; it speaks but as it must; there is no selective power, for the hand that fashions it, ordains.

HERMANN SMITH

### Periodicity of Rainfall

IN his second letter (*NATURE*, vol. x. p. 263) Governor Rawson makes the following remarks—"Mr. Meldrum, in his letter (vol. viii. p. 547), writes, that I have 'taken 1846 and 1871 as middle maxima years [in my first paper I also took 1848, whereas 1849 and 1872 are probably more correct.' Mr. Meldrum is in error as to my having taken 1846 as a middle maximum, as a reference to my former letter will show. . . . I demur to the changes to 1849 and 1872: to the first because, without any sufficient reason, a dry year (48°10 in.) is discarded, and a wet year (67°88 in.) is added; and to the second, not because it affects my calculations, but because no reason is given."

In reply, I beg to observe that 1846 is either a misprint for 1848, or that in my manuscript 6 was inadvertently written for 8. This, I submit, is evident from the words immediately following the mistake, namely, "in my first letter, I also took 1848."

If Mr. Rawson supposes, or if his remarks imply, that I made 1849 a middle maximum, to avoid the small rainfall of Barbados in 1847 (48°10 in.) and at the same time to take advantage of the large fall in 1850 (67°88 in.), in order to make out a favourable case, I beg to say that he is entirely mistaken; for long before I saw his rainfall returns, I had invariably taken 1849 as a middle maximum year. The only instance in which I took 1848 was, as I said, "in my first paper" read before the Meteorological Society of Mauritius on Oct. 10, 1872. In all subsequent papers on the subject, including one read before the Royal Society, 1849 was taken. Rightly or wrongly, therefore, the Barbados rainfall has been subjected to exactly the same treatment as that of the British Islands, the Continent of Europe, India, America, &c.

Assuming a causal connection between sun-spots and rainfall, it seemed to me that the effects, if any, would be most apparent about the times of the turning-points of the sun-spot curve, and that a comparison of the rainfall of each maximum period of three years with that of each minimum period of three years, for a considerable time and space, would be a preliminary test of the hypothesis. The difficulty was to know the exact epochs of maximum and minimum sun-spot frequency, and at the same time the rainfall for equal periods on either side of them. If we had the monthly rainfalls, and knew in what month the maximum and minimum of sun-spots occurred, it would be comparatively easy to compare the rainfalls for equal times with respect to the epochs. But there was another point to be considered, namely, that a cause requires time to produce its effect.

According to Prof. Wolf 1848.6 was a maximum epoch; which, I presume, means that the turning-point occurred in August 1848; the figures, however, might mean six-tenths of a year after 1848, or August 1849.

Taking August 1848 for the maximum epoch, the strict course, in order to place the epoch at the middle of thirty-six months, would be to give the rainfall from the 6th of February 1847, to the 6th of February, 1850. But this could not be done. It was necessary to choose a whole year as the middle maximum year. And the reason why 1849 was chosen in preference to 1848 was, that the object being to find whether the periodic changes indicated by sun-spots had any effect upon rainfall, and time being required for a cause to produce its full effect, there was a presumption that the maximum rainfall would take place after the maximum of sun-spots, somewhat in the way in which the maximum diurnal temperature occurs, not at noon, but an hour or two after noon.

For a similar reason 1872 was taken as a middle maximum in preference to 1871.

This allowance of time for the supposed cause to produce its effect is, though apparently unintentionally, made by Mr. Rawson himself when he adopts 1844, 1856, 1860, and 1867 as middle years; for, according to Wolf, the epochs were 1844.0, 1856.2, 1860.2, and 1867.1, that is, if I mistake not, early in each year; so that nearly two of each of the three years taken come after the epoch, while only one of them precedes it. By taking 1849, therefore, as a middle maximum year, we come nearer to the conditions observed with respect to the other epochs than we should do by taking 1848.

Before proceeding to deduce a few results from Mr. Rawson's valuable "Report upon the Rainfall of Barbados" from 1843 to

1871, with a copy of which he has favoured me, I would remark that he has made apparently some oversights in his letter. For example, he says, with reference to a comparison of the rainfalls at Fairfield and Halton, "but the rainfall at Fairfield during the last three years . . . is 1333 per cent. below that of Halton. Therefore 27 in. have to be added to the minimum average of 1843-45, which would increase the above excess of 10.6 in." But if the minimum average be increased by a percentage, would it not be well to increase also the maximum average of 1847-49 by the same percentage? If this be done, the excess is not altered in the least.

The earliest rainfall observations at Barbados, given by Mr. Rawson, were those taken at Fairfield from 1843 to 1850, after which there is a long blank. Now, the rainfall there during that period gives the following results:—

Min. years.	Rain.	Max. years.	Rain.
1843-45.....	163.7	1848-50.....	179.7

showing an excess of 16 inches in the maximum period.

The next earliest and most complete observations are those taken at Husbands; they commence with 1847, and have been continued without interruption. From them we get:—

Max. years.	Rain.	Min. years.	Rain.
1848-50.....	182.3	1855-57.....	188.1
1859-61.....	183.3	1866-68.....	162.8

365.6, 350.9

which gives an excess of 14.7 inches on the maximum side.

The greatest number of inter-comparable observations for the longest period are those taken at the eight stations, Binfield, Henley, Husbands, Grand View, Oughtersons, Halton, Edgecumbe, and St. Ann's, from 1855 to 1868; and I find that they give a mean excess of 56.9 inches on the side of the years of maximum sun-spot.

I do not think that these results are *opposed* to the hypothesis which Mr. Lockyer and myself have put forward. As a matter of fact, the rainfall of Barbados, as given by Mr. Rawson from 1843 to 1868, bears out the hypothesis if we take 1849 as a middle maximum in place of 1848; and it is for others to judge whether the reasons that have been assigned for the change from 1848 to 1849 (not for Barbados alone, but generally) are valid.

But it may be said that the rainfall of 1871-73 was opposed to the hypothesis. I have not the rainfall for those years before me. Granting, however, that they show a very considerable diminution, the question arises whether the favourable result of twenty-six years (1843-68) are to be upset by the unfavourable results of three years (1871-73)? Have we not in meteorology many such exceptions to well-established laws?

The rainfall at 250 stations in different parts of the world has now been examined, and the results are so decidedly favourable that it is practically of no consequence whether the experience of Barbados is for or against the theory. I think the more the subject is examined, the more clearly will the law come out; but we must be guided by facts, and not hesitate to discard this or any other theory when unsupported by facts.

Mauritius, Oct. 15

C. MELDRUM

### Ice-Caves

THE occurrence of snow and ice in an old mine during the month of June, mentioned by Mr. J. Clifton Ward in his interesting paper in *NATURE*, vol. xi. p. 309—to the accuracy of the greater part of which I can bear personal testimony—has a more exact parallel in the Alps than "a Swiss glacier," namely, a *glacière*. These remarkable caverns have been fully described by Mr. G. F. Browne in his able and pleasant work, "Ice-Caves of Switzerland and France;" and briefly by myself in "The Alpine Regions." Since the publication of that book I have seen others; and as one of these has never, I think, been described in any English work, I venture to take the opportunity of sending you a short account of it. It is in the Val d'Hérens, a short distance from Evolena, on the way to the Pic d'Arzinol, and is called the Pertuis Freiss. A slip or subsidence of part of a cliff appears to have cracked the rock and opened two joints, into one of which fissures one can descend. This is about four feet wide and generally some four yards high, the floor being a little below the level of the ground outside. The crevice comes to an end in about a dozen yards. Against the slightly sloping wall of rock rested some pendent sheets of ice, whose thickness rarely appeared to exceed three inches, and irregular patches of ice lay about the floor. The temperature of the air appeared to be a little above the freezing (unfortunately, I had

not a thermometer with me). It was a warm summer's day—July 23. The ice exhibited the usual prismatic structure, but the prisms seldom exceeded a third of an inch in diameter. I was informed that in winter it was choked up with snow. The other fissure also contained ice, but as it was less accessible, and seemed in no way different from the former, I did not enter it. The especial interest of this case is that it affords what I might call the most rudimentary type of a *glacière*; a natural ice-house, replenished every winter, and perhaps sometimes entirely cleared out during an unusually hot summer. The "Grotto" on Monte Tofana, near the Ampezzo Pass (which I have not been able to visit), is, I expect, another of this kind.

St. John's College, Cambridge T. G. BONNEY

[By a misprint "glacier" was put for *glacière* in the last paragraph of Mr. Ward's paper.—ED.]

### The Morse Code

THE following mnemonic device may be of some use to young telegraph students, and others, who wish to commit the Morse alphabet to memory. There is, I believe, a device employed in the Government schools, but it gives one so little help that I lately jotted down the subjoined scheme for my own instruction.

Let the vowels *a e i o u* and also *sh* represent the dots, and the remaining letters of the alphabet the dashes in the Morse code: the word attached to each letter will then express the signal for that letter. These words must be learnt; a task rendered easy by their commencing with or containing the letter they signify.

A	---	at	N	---	no
B	---..	base	O	---	P, Q, R
C	---	cave	P	---	Apps
D	---	die	Q	---	Q, Q, E, D
E	.	E	R	---	are
F	..	safe.	S	---	ass
G	---	Gnu	T	---	T
H	---	hush	U	---	Usk
I	...	is	V	---	Asov
J	---	Ujg	W	---	awl
K	---	kit	X	---	Faux
L	---	aloe	Y	---	yawl
M	---	my	Z	---	zwei

A few of the letters, e.g. J (the word for which might be regarded as a new way of spelling Ujiji), O, and Q, present a little difficulty, which some of your readers may lessen. As it is, these exceptional cases are so quickly impressed on the memory that the code thus learnt can be written in a surprisingly short time, and read soon afterwards. It is hardly possible the plan here suggested can be new, yet, as I have not met with anything similar, I venture to send it to you for publication.

W. F. BARRETT

### The Micrographic Dictionary—Pollen Grains

AT present I have to do with the "Micrographic Dictionary" and the two other works mentioned in my letter printed in NATURE, vol. xi., p. 286. If the pollen grains of *Minulus morchatus* are variable (as now stated by Mr. Cooke on the authority of Dr. Mohl), how is it that the figures and descriptions in the books mentioned are all alike? There is no variability here, but wonderful sameness both in illustrations and letter-press.

As the accuracy of my first simple observation has been called in question, I will add another. In the "Micrographic Dictionary," Pl. 32, Fig. 28, is given the pollen of *Sonchus palustris*. This, like that of the *Minulus*, is totally wrong, the reticulation is by no means correct, and the abundant spines with which this pollen grain is clad (so common in the Compositæ) are totally omitted. Now, on turning to the Rev. J. G. Wood's book, Pl. 3, Fig. 24, this erroneous figure is reproduced with incorrect reticulation and no spines, and on referring to Mr. Cooke's work, Pl. 2, Fig. 6, the same errors are again perpetrated.

W. C. SMITH

### OUR ASTRONOMICAL COLUMN

♄<sup>1</sup> AND ♄<sup>2</sup> RETICULI.—These stars of about the sixth magnitude appear to offer a similar instance of large and nearly equable proper motion to the well-known one

afforded by 36 Ophiuchi and 30 Scorpii, which was first pointed out by Bessel in the "Fundamenta Astronomiæ." If we compare Lacaille's positions (taking them from the reduced catalogue published by the British Association) with those given by the late Capt. Jacob from the Madras observations 1853-57, we find with the Pulkova precessions—

R.A.	Secular Proper Motion.		Arc of great circle.	Direction of motion.
	N. P. D.	Arc of great circle.		
♄ <sup>1</sup> ...	+ 237''·5	- 74''·9	130''·3	54°·9
♄ <sup>2</sup> ...	+ 238''·7	- 79''·6	133''·8	53°·4

The introduction of Brisbane's places would only modify the above figures in a trifling degree.

When competent observers in the southern hemisphere are provided with heliometers for research on stellar parallaxes, there will be no lack of objects to occupy their attention, and we may expect most important results from such investigations.

THE BINARY STAR  $\eta$  CASSIOPEÆ.—We may very soon be able to make a fair approximation to the orbit of this double star, and so, with Mr. Otto Struve's value for the annual parallax, form some idea of the real dimensions and mass of the system, as is already the case with  $\alpha$  Centauri and  $\gamma$  Ophiuchi. An orbit given by Mr. Powell, of Madras, in vol. xxi. of *Monthly Notices*, R. A. S., is probably vitiated by topographical error or errors. Struve's parallax is  $0''\cdot154 \pm 0''\cdot045$ .

THE BINARY STAR  $\alpha$  CENTAURI.—According to Mr. Powell's last elements, which are founded on measures up to 1870 inclusive, the components, at the present time, are nearly at their minimum apparent distance ( $1''\cdot2$ ), and the angle of position is advancing at the rate of  $10^\circ$  monthly. It may be hoped this fine object is receiving due attention from astronomers in the southern hemisphere at this critical period of the revolution. There would appear to be no probability of such difficulties attending observations at the passage of the peri-astron as those presented by  $\gamma$  Virginis in 1836, so far at least as can be judged from the measures to 1870.

RED STARS.—Amongst the red stars notified by the late M. Chacornac, is one which he estimated between the seventh and eighth magnitude, and of which he says, "éclat terne et nebulose." The position assigned identifies the star with No. 1172 of Rümker's Catalogue, whence for the commencement of the present year its right ascension is 4h. 16m. 16s., and polar distance  $67^\circ 19'7$ . Rümker calls it a sixth magnitude, and Argelander (Durchmusterung) an eighth. Although different eyes will not always agree in estimations of brightness of the ruddy stars, there appears here to be a suspicion of variable light. Another of Chacornac's isolated red stars he himself indicates as variable. It is Oeltzen 21356, called 6 mag. by Lalande (No. 41453), 5'6 by Argelander, 5 in the Washington Zone, 1848, July 24; while Chacornac remarks, "sometimes brighter and sometimes fainter than a star of the seventh magnitude near it," which is probably Oeltzen 21386. Position for 1875, R.A. 21h. 17m. 5s.; P.D.,  $111^\circ 22'7$ . Neither of these stars is in Schjellerup's Catalogue, but that list is very far from being a complete one.

ENCKE'S COMET.—The extreme faintness of this comet at the present appearance is attracting the attention of astronomers who have had most experience of the circumstances of previous returns. Last week we quoted the remark of M. Stéphan on this subject, and we learn from him that he was using a newly polished mirror in the great Foucault telescope of the Observatory of Marseilles. In 1868 and 1871 the comet's appearance was very similar to what it had been in previous years under analogous conditions. In discussing the probability of any real change in the comet's constitution, it may, however, be well to bear in mind that in the year 1842, when the peri-

helion passage occurred on the same day of April, Encke was very doubtful of the comet being visible at all in this hemisphere, and had contented himself with transmitting an ephemeris to Greenwich, to be passed on to the Cape of Good Hope. It was only after Dr. Galle had detected with the Berlin refractor, on the evening of February 8, a very faint nebulosity within 2' of the predicted position of the comet, that Encke communicated the ephemeris to the *Astronomische Nachrichten* (see No. 443). In 1842, on March 23, the comet was seen "distinctly in the twilight, with the moon shining brightly." At the beginning of the second week in April the condensation of light was very great, and a fine bright point was remarked: it was not seen in Europe after the 9th of this month.

#### BEARING OF METEOROLOGICAL RECORDS ON A SUPPOSED CHANGE OF CLIMATE IN SCOTLAND\*

IT is a belief very generally entertained that the climate of Scotland has undergone considerable change in recent years, the summers being less hot and the winters less severe than they used to be. This idea was advocated by Mr. M'Nab in his presidential address to the Edinburgh Botanical Society in November 1873, the facts adduced in support of it referring solely to vegetation. In this paper the question is examined exclusively from a meteorological point of view, and the examination is confined to monthly mean temperatures.

The following are the records which have been made use of:—1. Monthly mean temperatures from observations made at Gordon Castle, Banffshire, from July 1781 to November 1827; 2. The monthly temperatures given in Forbes' climate of Edinburgh (Trans. Roy. Soc. Edin., vol. xxii. p. 335); 3. Observations made at Dollar from 1836 to 1856, and from 1861 to 1874; and 4. Observations made at Elgin from 1855 to 1874. The mean temperatures of the months and the year were calculated for each of these four series of observations for the interval embraced by each, and then the differences of each month's mean temperature from the general mean for that month and station were set down in a table. Since the time over which each of these series of observations extended was sufficiently long to give a very close approximation to the true mean for the hour of observation and exposure of the thermometers, and since the separate months were only compared with the means for that place, the table may be regarded as representing very closely the *monthly variations* which have occurred in the temperature of Scotland during the past ninety-four years. It may be noted that the observations were made in two districts, viz., Gordon Castle and Elgin in the north, and Edinburgh, Dunfermline, and Dollar in the south.

The variations of each year, and of each month of each year, were then projected in curves, showing graphically the fluctuations which have occurred during this long period. The coldest year was 1782, being 3°·3 under the average, the deficiency of May of that year being 6°·7, and August 5°·9; then follow 1799 and 1816, being 2°·3; 1838, being 2°·0; and 1860, being 2°·4 under the average. The two warmest years were 1794 and 1846, the excess being respectively 2°·7 and 2°·9. During the nine years from 1787 to 1795, the temperature was generally above the average; the mean annual excess of the nine years being 1°·5. For the next quarter of a century temperatures were generally under the average. From this period to the present time there have occurred five fluctuations in the annual temperature above and below the average, differing in amplitude and duration, but giving no indication of a steady permanent change either way. Exceptionally warm and exceptionally cold months

are distributed over the period in such a manner as to show that substantially no permanent change has taken place in the temperature of any of the months.

Since, however, the eye may not be able easily to detect any steady rise or fall that may be going on owing to the sharply serrated character of the curves, other averages were calculated on the method of taking as the average of, say, January 1784, not the average of that year, but the average of the five years 1782, 1783, 1784, 1785, and 1786. All the averages were dealt with in this way, and the results projected in a set of thirteen new curves. From these consecutive five years' averages, it is seen that mild Decembers prevailed from 1787 to 1797, from 1822 to 1845, and from 1862 to 1867; and cold Decembers from 1798 to 1821, from 1846 to 1861, and from 1868 to the present time. It may be noted that in 1821 the remark might have been made from the previous forty years' observations, that the character of Christmas weather had undergone a great change, the Christmases of the latter part of the period being generally much more severe; and again, in 1843, looking at the long period of forty-seven years, beginning with 1796, it might have been said that the old-fashioned Christmas weather had almost ceased to occur in the latter half of this long period, and that the climate had undergone some great permanent change. Now, while both would have been right as to the facts (whether these facts were based on numerical data or on recollections), both would have been wrong in inferring a permanent change, even though the inference was based on the observations of half a century. Looking, however, at the ninety-four-years' period, we can only conclude that the weather of December, as regards temperature, is subject to large fluctuations, which differ both in intensity and duration, and that there is no tendency to a permanent increase or decrease.

One of the most interesting features of the curves is the similarity existing among them *inter se*. The curves for August and September closely resemble each other, as also do those for November and December, while that for October combines the main features of the two sets. The curve for January combines the main features of the curves for November and December on the one hand and February and March on the other, and so on with the other months.

The general result of the inquiry then is, that though large annual fluctuations of temperature have occurred, yet the warm and the cold cycles, extending over longer or shorter periods, are so distributed over these long intervals as to give no indication that there has been any tendency towards a steady increase or decrease in the temperature, or that any permanent change has taken place in the climate of Scotland. And since the same remark applies with equal force to the observations of the separate months, it follows that meteorological records give no countenance to the idea of a permanent change having occurred in the climate of Scotland either as regards summer heat or winter cold. It may be added that during the past seven years the temperature of July has been above its average respectively 2°·8, 1°·7, 2°·0, 0°·2, 1°·7, 1°·0, and 1°·8, and that of December, as compared with its average + 1°·5, - 4°·2, - 5°·6, - 1°·1, - 0°·8, + 3°·4, and - 7°·4; results quite in the opposite direction of the popularly entertained belief that the summers are colder and the winters milder than formerly.

ALEXANDER BUCHAN

#### NATURAL PHENOMENA IN SOUTH AMERICA\*

THE following notes may, I hope, possess some interest for the readers of NATURE. They were made during an expedition which took place last

\* Notes of some observations made by a telegraphist during a calling expedition from Pará to Cayenne.

\* Abstract of a paper read at the General Meeting of the Scottish Meteorological Society, held on 10th Feb.



summer, when a cable, designed for the Company by Sir William Thomson and Prof. Fleeming Jenkin, and manufactured by Messrs. Hooper, was laid by the large new telegraph ship *Hooper* between Parà and Cayenne on the coast of South America.

1. *Aspects of the Forests—Unconscious Action of the Sensorium.*—One of the first things which strikes a person at anchor in the Parà River is the increased clearness with which he can distinguish the details of the distant forest on the river's banks after he has repeatedly, but it may be unconsciously, looked at it. At first the forest presents the appearance of a vague dark-green wall uprising from the brimming yellow flood of the river, but by and by the eye clearly traces boughs, shapes, and even differences of tint in the foliage, which before had entirely escaped its observation. It seems, indeed, as if it were true sensitively as well as intellectually, of the eye as well as of the imagination, that "the oftener we looked at things the more we saw in them." It seems as if, within certain limits, the image of an object became more distinct in our consciousness the oftener it impressed itself on the retina, or that our perception became, unconsciously to us, more acute the oftener it was exercised upon the same object. This appears to be true also of the other senses; for example, a chemist has to smell or taste some time before he can discriminate the ingredients of a mixture, and the peculiar cries of the street vendor in time become intelligible to us without any apparent effort on our part.

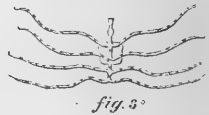
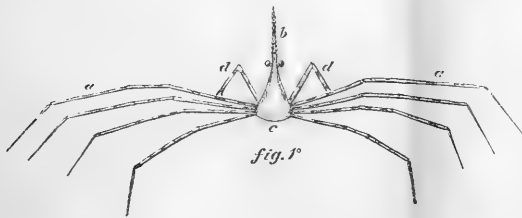

3. *Flying Fish, "Portuguese man-of-war,"* and some other fishes, were seen most frequently in the morning. The Portuguese man-of-war is then very difficult to distinguish amidst the general unrest of the slate-coloured waves. He is usually found solitary, or with a single companion, in the fleet to which he belongs. I was surprised to find that the larger ones were, however, frequently accompanied by a school of little fishes like sardines, which twinkled around them in the water like so many attendant sprites. Their object in being there was doubtless to get food, but how this is done it is difficult to know.

The flying-fish were sometimes extremely numerous. They turned both horizontal and upward vertical curves in the air during their short flight, which resembles that of a mud-lark. It seemed to me that they vibrated their wings rapidly on first starting, so as to assist them to gain a sufficient height, after which they simply skimmed till they touched water again and gave themselves a fresh impulse. Their wing-power is certainly, as yet, unable to sustain flight, although it is capable of assisting and diverting it.

4. *A Barracouta.*—In the River Parà estuary a fine Lusty Barracouta leaped from the water into the ship, a height of ten or twelve feet, nearly striking our chief engineer in the face. He caught it. The back was beautifully chased with dark-green, blue, and gold; the sides and belly with paler green, blue, and gold; and three rows of metallic-looking spots were ranged along the sides like flakes of citrate of iron and quinine. It had a single row of sharp triangular teeth in each jaw.

Within the forests the absence of grass is at once noticeable. The only plant, indeed, resembling grass, is an orchid which grows as if it had been merely tossed up into the trees. It is very like that sharp-edged sword-bladed grass so troublesome to the farmer and difficult to eradicate from his field. The absence of grass may be attributed to the great evaporation and non-retentiveness of the soil, or to the deep shade of the thick underwood.

In the vicinity of Parà I noticed two trees of different species so entirely locked together as to have one common trunk for seventy or eighty feet of altitude. Near Lake George, in North America, there is, I believe, a similar phenomenon, of which the guide, who points it out, wisely remarks, "Whom God hath joined, let no man put asunder."

2. *Thunderstorms.*—Another thing which cannot fail to "strike a stranger" is the prevalence of lightning at Parà. There is a display usually every afternoon. The locality seems to lie between that city and the mouth of the river. Thunder is rarely audible. The flashes are large and of a flame-colour, and proceed out of widespread dark clouds. It was my good fortune to witness a rain and thunder storm on a large scale there. At every flash a bluish glare suddenly illumined the broad river even to the opposite shore, the flooded streets, the piles of buildings, and the shipping so distinctly that each rope and spar might have been numbered. The flashes succeeded each other with marvellous rapidity, but were not in every case accompanied by audible thunder.

5. *Phosphorescence.*—This phenomenon was sometimes very beautiful. It owes its appearance, perhaps, not so much to conditions of atmosphere, &c., as to prevalence of the creatures which give rise to it. We remarked the boundaries of a thick colony of them as clearly defined amongst the surrounding population as land is from sea on a map. The usual appearance of this phosphorescence and of the flight of flying-fish are accurately described by the Rev. Canon Kingsley in "At Last."

6. *St. Roque Current.*—We found the speed of this current to be as much as four knots an hour sometimes, instead of two and two-and-a-half as marked on the charts. In lat.  $3^{\circ} 42' N.$ , long.  $48^{\circ} 15' W.$ , we found it skirting the edge of the fringing reef, and so well defined from the rest of the ocean, that in crossing it the ship was half in current water and half in ocean, and the agitation at the line of demarcation could be seen for miles. At the surface we found its temperature to be  $82^{\circ} F.$ , and at the bottom, 150 fathoms deep, we found the temperature only  $59^{\circ} F.$

7. *Live Specimens.*—Off the mouth of the Amazon we had occasion to pick up some cable which had been submerged a little over a month. In the vicinity of the lighthouse, among the sandy shoals of the River Parà estuary, the cable was completely encrusted with tiny barnacles. Beyond this, and further out at sea, it came up covered with submarine vegetation, crabs, and shells of curious description. Among the latter were a pink, semi-transparent *Leda*, with onyx-like streaks of white; and a nummulite. The seaweeds were in great variety

clinging to the cable, sometimes in thick groves of red and yellow algæ, slender, transparent, feathery grasses, red, slimy fucoids, and tufts of amethyst moss. We found branching coral plants, upwards of a foot in height, growing on to the cable, the soft skeleton being covered with a fleshy skin, generally of a deep orange colour. Sometimes a sponge was found attached to the roots of these corals, and delicate calcareous structures of varied tints encrusted the stems of all these plants, and served to ornament as well as strengthen them. Parasitic life seems to be as rife under these waters as it is on these shores. Many star-fishes, zoophytes, and curious crabs were likewise pulled in, clinging to the cable. The latter were frequently completely overgrown with the indigenous vegetation of the bottom, or of the colour of the sand there, and so were scarcely distinguishable from it. Others, although not so covered, were found to have the same tints as the vegetation they inhabited, and even in structure resembled the latter somewhat. Others, again, were perfectly or partially transparent; and one most beautiful creature, perhaps new to science, united singularly enough in its person several prevailing colours of the bottom. Its slender limbs (Fig. 1), like jointed filaments of glass, were stained here and there of a deep topaz brown (a). Its pointed snout (b) was of a deep scarlet; its triangular body (c) of a light yellow; its eyes were green, and its tiny hands (d) an amethyst blue.

Another very active crab or water-beetle was also picked up. It was quite transparent, and had bright green highly convex eyes (Fig. 2).

Another creature (Fig. 3) of quite a different description was also picked up. It was more like a water-spider than anything else. Its transparent hair-like limbs were dappled with dull green, and it seemed a mere skeleton

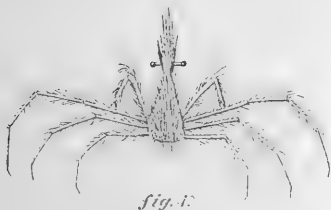

Fig. 1.

framework made to carry a small white sac containing entrails, which was slung underneath. These three distinguished specimens were entirely free from parasitic weeds, and were the only ones of their kind observed. Many crabs (Fig. 4), generally resembling Fig. 1 in shape, but altogether ruder in form, were found in plenty, all bearded with moss in the manner shown. While looking at these frail organisms, one was forced to conclude that there must surely be little disturbance in their habitats.

The temperature varied from 79° F. in the deeper water to 83° F. in the shallower. The cable was most thickly encrusted with vegetation in depths of thirty to forty fathoms, and there was a very sensible falling off when the depth reached sixty fathoms, and the water became saltier and more free from silt.

The specimens, Figs. 1 and 2, were found in water of thirty and forty fathoms respectively, about lat. 0° 55' N., long. 48° 8' W., off the coast of Marajo, or Joannes Island.

The specimens, Figs. 3 and 4, were found in water of sixty fathoms, sixty miles off the coast, about lat. 2° 56' N.

The few unlucky wafers observed of the many which came up are at least sufficient to hint at the wonderful variety of submarine life there may be in the littoral zones of these regions, which are well worthy of being

examined by naturalists; and picking up cables suggests a novel way of dredging for them.

8. *Fishes' Bites*.—The cause of our picking-up operations is in itself worthy of remark. We found that the cable had been bitten in several places by fishes powerful enough to displace the iron sheathing and pierce the cable to the core with their teeth, pieces of which we found sticking in the bitten places. There is reason to believe that the electric current had given them a shock and caused them to quit their morsel rather hastily. The bites were all located in the cable off the Delta of the Amazon, and had undoubtedly taken place when the cable was freshly laid, and before it was rendered inconspicuous and unattractive by the submarine fauna and flora.

J. MUNRO

#### THE BIRMINGHAM COLLEGE OF SCIENCE

SOME months ago we intimated that Sir Josiah Mason had set aside a munificent sum of money wherewith to erect and endow a College of Science in Birmingham. On Tuesday last, his eightieth birthday, the donor laid the foundation-stone of the building, in presence of a large gathering, composed of representatives of various public bodies.

We have already given some details of Sir Josiah Mason's scheme, which appears to us exceedingly judicious, liberal, and comprehensive. The entire sum to be spent by the wise and generous founder will amount to upwards of 100,000*l.*, of which 65,000*l.* will be reserved for endowment. The plan of education comprises courses of instruction in mathematics, abstract and applied; physics, both mathematical and experimental; chemistry, theoretical, practical, and applied; the natural sciences, especially geology and mineralogy, with their application to mines and metallurgy; botany and geology, with special application to manufactures; physiology, with special reference to the laws of health; and the English, French, and German languages. The course of study may also, in the discretion of the trustees, include such other subjects of instruction as will conduce to a sound practical knowledge of scientific subjects, excluding mere literary education. It is provided that popular or unsystematic instruction may be given gratuitously or by fees in the discretion of the trustees, and shall be open to all persons without distinction of age, class, creed, race, or sex. Theology and theological or religious subjects are absolutely excluded from the curriculum. Students must be between the ages of fourteen and twenty-five, and must pass such preliminary examination as the trustees may direct. In exceptional cases, students above twenty-five will be admitted; but these must not exceed the proportion of one to ten. The founder has decided that a certain proportion must be selected on grounds which are reasonable and not too narrow. The original trustees are Mr. W. C. Aitken, Mr. J. Thackray Bunce, Dr. Gibbs Blake, Dr. Heslop, Mr. G. J. Johnson, and Mr. George Shaw, and the Town Council of Birmingham is empowered to appoint five additional trustees after the death of the founder. The building, which is in the early pointed style, from designs by Mr. J. A. Cossins, architect, of Birmingham, will occupy an area of about an acre, with frontages on either side of 149 feet and 127 feet respectively, in the immediate vicinity of the Town Hall, the Midland Institute, and the new municipal buildings.

After the ceremony of laying the foundation-stone, a meeting was held in the Queen's Hotel, at which, among others, Mr. John Bright was present, and paid a deserved tribute to the far-seeing liberality of the founder of the College. Sir Josiah Mason himself, in an address marked by moderation and great sagacity, gave a simple account of his own career, in which he has amassed a fortune by patient industry, and spoke with great emphasis of the

difficulties which he and his contemporaries had to encounter in their youth from the want of any means of carrying on their education, especially in science, during the intervals they had to spare from work. The aims which he has in view in founding the College may be gathered from the following extract from his address:—

"Whatever is necessary for the improvement of scientific industry and for the cultivation of art, especially as applied to manufactures, the trustees will be able to teach; they may also, by a provision subsequent to the original deed, afford facilities for medical instruction; and they are authorised, and indeed enjoined, to revise the scheme of instruction from time to time, so as to adapt it to the requirements of the district in future years, as well as at the present time. It is not my desire to set up an institution in rivalry of any now existing; but to provide the means of carrying further and completing the teaching now given in other scientific institutions and in the evening classes now so numerous in the town and its neighbourhood, and especially in connection with the Midland Institute, which has already conferred so much benefit upon large numbers of students, and which I am glad to see represented here to-day. My wish is, in short, to give all classes in Birmingham, in Kidderminster, and in the district generally, the means of carrying on, in the capital of the Midland district, their scientific studies as completely and thoroughly as they can be prosecuted in the great science schools of this country and the Continent; for I am persuaded that in this way alone—by the acquirement of sound, extensive, and practical scientific knowledge—can England hope to maintain her position as the chief manufacturing centre of the world. I have great and I believe well-founded hope for the future of this foundation. I look forward to its class-rooms and lecture-halls being filled with a succession of earnest and intelligent students, willing to learn not only all that can be taught, but in their turn to communicate their knowledge to others, and to apply it to useful purposes for the benefit of the community."

Thus it will be seen that Sir Joseph Mason's design has been conceived in a spirit of true wisdom; he perceives that the prosperity of Birmingham, like the prosperity of the country at large, depends upon the extent to which every branch of history is founded upon a broad and deep scientific basis. He evidently does not intend that his institution will become a mere "Technical" College. We should think that the trustees will carry out the design and wishes of the founder if they aim to make the Mason College do for Birmingham what the Owens College is doing for Manchester. Moreover, we hope that as in the case of Manchester other endowments will be added to that of the wise and generous founder, and that thus the trustees will be able ultimately to carry out his ideas to their fullest development. Meantime all who wish for the highest prosperity of the country, will feel warm gratitude to and admiration for Sir Joseph Mason, a true benefactor to Birmingham, to England, and to Science.

#### NOTES

WE can only, this week, express our regret—a regret which is universal—at the death of Sir Charles Lyell, Bart., F.R.S., which took place on Monday last. Sir Charles was born on Nov. 14, 1797, so that he was nearly 78 years of age. We hope to give an obituary notice in our next number.

WE regret to announce the death, on Feb. 17, of the celebrated astronomer, Prof. F. W. August Argelander, at Bonn. He was born at Memel on March 22nd, 1790, and began his studies at the University of Königsberg, where he soon became a zealous pupil of Bessel, and in 1820 his official assistant at

the Observatory. Three years later, he followed a call to Abo (Finland), and his principal occupation there was the observation of fixed stars showing large proper motions. These observations were continued at Helsingfors, where he settled in 1832. He succeeded in pointing out nearly 400 fixed stars, which in the time from 1755 until 1830 have moved over more than fifteen seconds in the direction towards the constellation of Hercules. In 1837, when his pamphlet "On the Motion of the Solar System" had appeared, he received an invitation from the University at Bonn, where an observatory was being built, which was completed in 1845. Here he continued his studies most energetically, and particularly investigated the variable stars. In his "Uranometria" he gave excellent determinations of star-magnitudes. His celestial atlas, which was only completed a little while ago, comprises all stars from the first to the tenth magnitude; it is entirely based on his own determinations of position, and decidedly ranks amongst the best works of the kind.

AN important telegram was received by the French Academy of Sciences, at its sitting of the 22nd February, from M. Mouchez, the head of the St. Paul Transit Station. It is said that the observation of internal contacts was perfectly successful. The external contacts were not good, owing to clouds, the weather having been bad for three months. Numerous photographs have been taken. A steamer had left St. Paul for Cherbourg, bringing the detailed results of the observations.

AT the same sitting, M. Dumas announced that the Academy had received, almost at the same moment, two different parcels sent by two different ships, both consisting of documents sent by Capt. Fleuriot, the head of the Pekin Transit Expedition. These parcels, having been sealed, will not be opened for some time to come.

THE following quaint extract from the *Gazetteer* of May 31, 1769, will no doubt have some interest for our readers at the present time:—"The Transit of Venus over the sun is a phenomenon whereby the astronomers can determine the distance of the sun from the earth, and the dimensions of the whole solar system, more accurately than by any other method. Such a transit will be visible near London on Saturday afternoon, June 3, a little after seven o'clock, if the weather be fair; and never more for this age, nor perhaps for many ages to come, will such a phenomenon be seen in this quarter of the world. The curious, both ladies and gentlemen, who are desirous of being entertained with a sight of this phenomenon, may have the best situation for that purpose, with the assistance of proper persons and telescopes, at Mr. Lightfoot's, at Denmark Hall, on Camberwell Hill, in the road towards Dulwich, where the best of accommodations and wines may be had."

AN official intimation has been received from Dr. Neumayer confirming the announcement, as regards the Deutsche Seewarte at Hamburg, contained in the *Times* telegram noticed in our last number. It appears that the Government have purchased Herr v. Freeden's interest in the establishment, and that he has no longer any connection with it. It does not yet appear what is the relation of the Hydrographic Office at Berlin, of which Dr. Neumayer is chief, to the Deutsche Seewarte, which is also under him.

A SOCIETY has been formed in Calcutta for obtaining spectroscopic observations of the sun.

WE are much gratified to hear that the Committee of the Chester Society of Natural Science recommend for the consideration of the members that a permanent memorial to the late Canon Kingsley, their founder and president, be established. The memorial proposed and recommended is (1) That a Scholarship (including a medal), to be called "The

Kingsley Memorial," be founded for the encouragement of Natural Science, to be open to residents and students within the district embraced by the society, subject to such regulations as may be hereafter agreed upon. 2. That if a sufficient fund be raised, a medal may from time to time be given by the Chester Society of Natural Science, for original research within the district of the aforesaid society, and that the medal be called "The Kingsley Memorial Medal."

We are glad to see from the report of the Syndicate appointed by the Senate of Cambridge University to organise and superintend courses of lectures and classes at a limited number of populous centres, that the scheme is working well and is embracing a rapidly widening area. In the first term of 1873-4, the number of towns which took advantage of the scheme was three—Nottingham, Derby, and Leicester. This number increased to seven in the following term, and to twelve in the first term of 1874-5. During the present term lectures and classes are being carried on in the following sixteen centres:—Nottingham, Derby, Leicester, Lincoln, Chesterfield, in the Midland district; Leeds, Bradford, Keighley, Halifax, Sheffield, in the Yorkshire district; Stoke-on-Trent, Hanley, Burslem, Newcastle-under-Lyme, in the South Staffordshire district; Liverpool and Birkenhead in the Liverpool district. The subjects on which the lecturers are giving instruction during the present term are Political Economy, English Constitutional History, English Literature, Logic, Physical Geography, Geology, Astronomy, Physical Optics and Spectrum Analysis. A course of lectures is generally concluded in one term, though occasionally it extends over a longer period. The term's course comprises the delivery of twelve weekly lectures and the holding of twelve weekly classes. During the present term the number of lecturers employed is thirteen; and the total number of pupils attending the courses is about 3,500; and the sum payable to the University for the teaching, examination, and certificates is 1,150*l*. The Syndicate recommend the adoption of a standing Syndicate for the organisation and superintendence of the lectures. A gentleman in Nottingham has offered the sum of 10,000*l*., to be placed in the hands of trustees, towards the furtherance of this object in that town, provided the Corporation of Nottingham will erect buildings for the accommodation of the University lecturers, to the satisfaction of the Syndicate of the University of Cambridge.

A SERIES of (Davis) Lectures upon zoological subjects will be given in the New Lecture Room, in the Zoological Society's Gardens, Regent's Park, on Thursdays, at 5 P.M., after Easter:—April 15, "Monkeys and their Distribution," by Dr. P. L. Sclater, F.R.S.; April 22, "Sea-Lions," by J. W. Clark, M.A.; April 29, "Seals and the Walrus," by J. W. Clark, M.A.; May 6, "Deer and their Allies," by Prof. Garrod; May 13, "Sheep, Oxen, and Antelopes," by Prof. Garrod; May 27, "Camels and Llamas," by Prof. Garrod; June 3, "Elephants," by Prof. Flower, F.R.S.; June 10, "Kangaroos," by Prof. Mivart, F.R.S.; June 17, "Pheasants and their Allies," by Dr. P. L. Sclater, F.R.S.; June 24, "The Locomotion of Animals," by Dr. Pye Smith. The lectures will be free to Fellows of the Society and their friends, and to other visitors to the Gardens.

WILLIAM PARKINSON WILSON, Professor of Mathematics at the Melbourne University, died suddenly on Dec. 11. He was Senior Wrangler in 1847, and a Fellow of St. John's, Cambridge, and arrived in the colony in 1855 as a member of the first professional staff of the University, which he has zealously served ever since. The Professor was everywhere respected. He was, the *Times* correspondent states, at the head of all scientific movements, devoting himself energetically to anything which promised to promote the intellectual progress of the colony. The selection of his successor at the University is entrusted to Prof. Adams, of Cambridge.

A MUNIFICENT gift has been made to Melbourne University. Mr. Samuel Wilson, of Ercildou, who recently gave 1,100*l*. to the Acclimatisation Society, has sent 30,000*l*. to the Chancellor, intended for the erection of a hall, but free of conditions, and to be otherwise applied if the authorities think fit.

THE Khedive has instructed Dr. Schweinfurth to organise an African Geographical Society in Egypt.

A GRANT of 50*l*. has been made from the Worts Travelling Scholars' Fund (Cambridge) to Arthur Marshall, B.A., of St. John's, to enable him to visit Naples for the purpose of using Dr. Dohrn's zoological station and making researches in natural history, with the understanding that he send specimens to the University, accompanied by reports.

ALPHA FIBRE, or Esparto Grass (*Machrochloa tenacissima*, Kth.), the closely compressed bundles of which are so familiar to us either in stack at wharves or in barges on the Thames, in course of transit to the various paper-mills, has created more than usual interest of late, owing to the report that the supply was becoming exhausted. In contradiction to this it is satisfactory to note, on the authority of Col. Playfair, the Consul-General at Algiers, that enormous tracts of land on the high plateaus in all the provinces of Algeria are covered with the plant. Thus, in the province of Algiers it covers an area of about 2,500,000 acres. In the province of Oran the extent of the Alpha growth is almost unlimited. In the circle of Daïa it is stated to cover a space of about 900,000 acres, while in the subdivision of Mascara there is an immense field for its exploration. In the several divisions of the province of Constantine it is estimated that a total of about 570,000 acres are under growth of this substance. These figures alone show an aggregate of some 3,970,000 acres of Esparto known to exist in Algeria. The difficulty, however, is in the want of proper roads or easy means of transport by which the material could be brought to the sea or a railway station. Col. Playfair says that practically there is no limit to the supply of Alpha procurable from Algiers; all that is required is the establishment of railway communication, and the Government of the colony is prepared to sanction the construction of lines, either by French or foreign capitalists, on the most liberal terms. Several companies have been formed for the purchase and exportation of this fibre, which is becoming more sought for in proportion to the increasing demand for paper. The Algerian authorities are quite alive to the necessity of encouraging all such commercial enterprises as may tend to develop this important branch of commerce.

IN a communication to the *Pharmacist* (Chicago) for last month, Mr. H. H. Babcock says he is convinced that *Cypripedium spectabile* and *C. pubescens* are capable of producing poisonous effects, on himself at least, similar to those caused by *Rhus toxicodendron*. He bases this statement upon the fact of his having experienced such symptoms after gathering the plants in question several seasons in succession. It seems scarcely possible that these plants, which have long been in cultivation in this country, possess the noxious properties attributed to them; the general properties of the family to which they belong are so different. However, one direct experiment might settle the question.

DR. ALLEYNE NICHOLSON, Professor of Biology in the College of Physical Science in Newcastle-upon-Tyne, has been offered and accepted the chair of Natural History in the University of St. Andrew's.

PROF. GABB reports continued progress in his geological and ethnological survey of the Talamanca district in Costa Rica. It may be remembered that Prof. Gabb was invited several years ago, by the Government of Costa Rica, to take charge of an investigation into the resources of the country, and certain reports of his operations from time to time have shown very

satisfactory progress. He has now accomplished the Talamanca survey, and will probably extend his researches into other parts of the country, particularly that bordering upon the Pacific coast, his previous explorations having been confined to the Atlantic slope. With only four assistants besides Indian labourers, Prof. Gabb has surveyed the entire tract, of about 3,000 square miles, from the borders of civilisation on the north to the borders of Panama, and from the Atlantic to the crest of the Cordilleras; and this he has mapped out more accurately than any other equal area of Costa Rica has been surveyed, not excepting the section where the towns are situated. He also gives reliable information and statistics about an agricultural country sufficiently large, fertile, and healthful to support the entire population of Costa Rica, but which as yet contains only 1,226 Indians and twelve foreigners, of whom only one is white. It is watered by one river, which is navigable throughout the year, and which reaches within thirty miles of the most remote portion of a country valuable for agricultural purposes. In addition to the survey proper, as referred to, information has been gathered in regard to the mineral resources of the region and its animal and vegetable life, immense collections of both, as previously stated, having been sent to the Smithsonian Institution for identification. Among the number are one hundred specimens of monkeys alone, while the other mammals, birds, &c., are in due proportion. The exhaustive inquiries prosecuted into the ethnology of the country have resulted in very rich collections, which have likewise been forwarded to Washington. Numerous vocabularies, with several dialects, have also been obtained, which offer much of promise to the philologist. It is greatly to be hoped that Prof. Gabb's inquiries may be continued, with Costa Rica as a base, until they include the whole of the unknown portions of Central America.

THE *Kölnische Zeitung* of Feb. 10 gives an account of Prof. Böhm's (Dorpat) researches on revival after cases of poisoning. He succeeded in reviving cats which had been poisoned by injection of potash salts into their veins, after forty minutes' duration of a state which was in no way different from actual death, the action of the heart and respiration having completely ceased. He obtained these results by artificial respiration and simultaneous compression of the breast in the vicinity of the heart. The professor points out the importance of the latter point, which he deems as essential as the action of the lungs. In any case his researches are of high interest for the relation they bear upon the revival of poisoned persons.

THE *Bohemia* reports extremely heavy snowstorms which took place in a part of Moravia and Bohemia on Feb. 5, and caused great damage to railways, several trains being thrown off the lines, luckily without much injury to passengers. At Znaim (Moravia) the storm was so violent at noon that it was impossible to see more than three yards ahead.

THE *Oberschlesische Volkszeitung* of Feb. 1 reports the discovery of some colossal remains of the Mammoth (*Elephas primigenius*) near Ober Glogau (Silesia).

THE *Neue Freie Presse* announces that Herr R. Falb, of Vienna, discovered a new variable star, near  $\alpha$  Orionis, on the night of Jan. 31. The discovery was confirmed on the same night by Prof. Oppolzer at his private observatory, and on subsequent nights by the astronomers at the Imperial Observatory of Vienna. The star is visible with the naked eye.

PROF. ASA GRAY, in a paper in the February number of *Silliman's Journal*, on the question, "Do Varieties wear out, or tend to wear out?" comes to the conclusion that from the scientific point of view, sexually propagated varieties, or races, although liable to disappear through change, need not be expected to wear out, and there is no proof that they do; but non-sexually propagated

varieties, though not liable to change, may theoretically be expected to wear out, but to be a very long time about it.

WE are glad to see that the Watford Natural History Society is now completely organised and fairly set a-going. At a recent meeting officers were elected, and a *conversazione* was afterwards held. The president chosen is Mr. John Evans, F.R.S., and Mr. J. Gwyn Jeffreys, F.R.S., is one of the vice-presidents. The first regular meeting is to be held on March 11, when Mr. J. L. Lobley, F.G.S., one of the members of the Council, will read a paper on "The Cretaceous Rocks of England."

ON the 10th inst., at six o'clock in the evening, a large aërolite was observed at Paris, in the department of the Marne, at Orleans, and at Belleisle en Mer. No noise was heard, but the display of light was magnificent. The track was visible for a time varying from a quarter to half an hour.

SEVERAL large land-slips are reported as having taken place on the Danish island of Møen, on a chalky rock named "Møensklint;" from another one, called "Jetterbrinken," a piece of several million cubic yards has fallen down. These occurrences are ascribed to enormous changes in the temperature which have lately taken place in that locality.

THE Royal Geological Society of Ireland have just published Part I. vol. iv., new series, of their journal. It contains: On a new genus of fossil fish of the order Dipnoi, by Dr. Traquair; On the microscopic structure of Irish granites and of the Lambay porphyrite, by Prof. Hull; On a bed of fossiliferous "kunkur," by J. E. Gore; On the Leinster coal-field, by J. McC. Meadows; On a raised estuarine beach at Tramore Bay, by E. Hardman; On the elevated shell-bearing gravels near Dublin, by the Rev. Maxwell Close; and Remarks on the genera *Paleochinus* and *Archeocidaris*, by W. H. Baily.

THE Forty-third Annual Report of the Royal Zoological Society of Ireland has just been published. The number of visitors to the gardens of the Society during 1874 was 109,923, and the receipts from the same, 1,442*l.* 14*s.* 4*d.* The number of visitors would appear to have been the smallest during the last ten years, but owing to an increase of the admission fees the income is scarcely below that of the best of the ten years. The Council propose to construct "an Elephant Compound on the plan of those so well known in the London Gardens," the total cost of which will amount to 150*l.*

THE additions to the Zoological Society's Gardens during the last week include two Feline *Douracoulis* (*Nyctipithecus felinus*) and two Squirrel Monkeys (*Saimaris sciuroa*) from Brazil; a Saffron Cock of the Rock (*Rupicola crocea*) from Demerara; and a Grey Mullet (*Mugil capito*), twelve Cottus (*Cottus bubalis*), and eighteen Basse (*Labrax lupus*), all British, deposited and purchased.

#### PRELIMINARY INQUIRY INTO THE EXISTENCE OF ELEMENTS IN THE SUN NOT PREVIOUSLY TRACED \*

IN a paper communicated to the Royal Society on December 12, 1872 (Phil. Trans. 1873, p. 253), I have shown that the test formerly relied on to decide the presence or absence of a metal in the sun, namely, the presence or absence of the brightest and strongest lines of the metal in question in the average solar spectrum, was not a final one, and that the true test was the presence or absence of the longest lines of the metal: this longest line being that which remains longest in the spectrum when the pressure of the vapour is reduced.

Of the test in question I have said in the paper already mentioned, "It is one, doubtless, which will shortly enable us to

\* Extract from a memoir presented to the Royal Society in November 1873, which has just been printed in the "Philosophical Transactions."

determine the presence of new materials in the solar atmosphere, and it is seen at once that to the last published table of solar elements—that of Thalén—must be added zinc, aluminium, and possibly strontium, as a result of the new method.\*

In order to pursue the inquiry under the best conditions, complete maps of the long and short lines of all the elements are necessary. It is, however, not absolutely necessary for the purposes of a preliminary inquiry to wait for such a complete set of maps, for the lists of lines given by the various observers may be made to serve as a means of differentiating between the longest and shortest lines, because I have also shown that the lines given at a low temperature, by a feeble percentage composition, or by a chemical combination of the vapour to be observed, are precisely those lines which appear longest when the complete spectrum of the pure dense vapour is studied.

Now with regard to the various lists and maps published by various observers, it is known (1) that very different temperatures were employed to produce the spectra, some investigators using the electric arc with great battery power, others the induction spark with and without the jar; (2) that some observers employed in certain cases the chlorides of the metals the spectra of which they were investigating, others used specimens of the metals themselves.

It is obvious, then, that these differences of method could not fail to produce differences of result; and accordingly, in referring to various maps and tables of spectra, we find that some include large numbers of lines omitted by others. A reference to these tables in connection with the methods employed shows at once that the large lists are those of observers using great battery power or metallic electrodes, the small ones those of observers using small battery power, or the chlorides. If the lists of the latter class of observers be taken, we shall have only the longest lines, while those omitted by them and given by the former class will be the shortest lines.

In cases therefore in which I had not mapped the spectrum by the new method of observation referred to in my paper, I have taken the longest lines as thus approximately determined; for it seemed desirable, in view of the very large number of unnamed lines, to search at once for the longest elemental lines in the solar spectrum without waiting for a complete set of maps.

A preliminary search having been determined on, I endeavoured to get some guidance by seeing if there was any quality which differentiated the elements already traced in the sun from those not traced; and to this end I requested my assistant, Mr. R. J. Friswell, to prepare two lists showing broadly the chief characteristics of the elements traced and not traced. This was done by taking a number of the best known compounds of each element (such, for instance, as those formed with oxygen, sulphur, chlorine, bromine, or hydrogen), stating after each whether the compounds in question were unstable or stable. Where any compound was known not to exist, that fact was indicated.

Two tables were thus prepared, one containing the solar, the other the more important non-solar elements (according to our knowledge at the time).

These tables gave me, as the differentiation sought, the fact that in the main the known solar elements formed stable oxygen-compounds.

I have said in the main, because the differentiation was not absolute, but it was sufficiently strong to make me commence operations by searching for the outstanding strong oxide-forming elements in the sun.

The result up to the present time has been that *strontium*, *cadmium*, *lead*, *copper*, *cerium*, and *uranium*,\* in addition to those elements in Thalén's last list, would seem with considerable probability to exist in the solar reversing layer. Should the presence of *cerium* and *uranium* be subsequently confirmed, most of the iron group of metals will thus have been found in the sun.

As another test, certain of those elements which form unstable compounds with oxygen were also sought for, gold, silver, mercury being examples. None of these were found.

The same result occurred when the lines due to the jar-spark taken in chlorine, bromine, iodine, and those of some of the other non-metals were sought, these being distinguishable as a group by formation of compounds with hydrogen.

Now other researches, not yet completely ready for publication, have led me to the following conclusions:—

1. The absorption of some elementary and compound gases is limited to the most refrangible part of the spectrum when the

gases are rare, and creeps gradually into the visible violet part, and finally to the red end of the spectrum, as the pressure is increased.

II. Both the general and selective absorption of the photospheric light are greater (and therefore the temperature of the photosphere of the sun is higher) than has been supposed.

III. The lines of compounds of a metal and iodine, bromine, &c., are observed generally in the red end of the spectrum, and this holds good for absorption in the case of aqueous vapour.

Such spectra, like those of the metalloids, are separated spectroscopically from those of the metallic elements by their columnar or banded structure.

IV. There are in all probability no compounds ordinarily present in the sun's reversing layer.

V. When a metallic compound vapour, such as is referred to in III., is dissociated by the spark, the band spectrum dies out, and the elemental lines come in, according to the degree of temperature employed.

Again, although our knowledge of the spectra of stars is lamentably incomplete, I gather the following facts from the work already accomplished with marvellous skill and industry by Secchi of Rome.

VI. The sun, so far as the spectrum goes, may be regarded as a representative of class ( $\beta$ ) intermediate between stars ( $\alpha$ ) with much simpler spectra of the same kind, and stars ( $\gamma$ ) with much more complex spectra of a different kind.

VII. Sirius, as a type of  $\alpha$ , is (1) the brightest (and therefore hottest?) star in our northern sky; (2) the blue end of its spectrum is open; it is only certainly known to contain hydrogen, the other metallic lines being exceedingly thin, thus indicating a small proportion of metallic vapours; while (3) the *hydrogen lines in this star are enormously distended*, showing that the chromosphere is largely composed of that element.

There are other bright stars of this class.

VIII. As types of  $\gamma$  the red stars may be quoted, the spectra of which are composed of channelled spaces and bands. Hence the reversing layers of these stars probably contain metalloids, or compounds, or both, in great quantity; and in their spectra not only is hydrogen absent, but the metallic lines are reduced in thickness and intensity, which in the light of *V. ante*, may indicate that the metallic vapours are being associated. It is fair to assume that these stars are of a lower temperature than our sun.

I have asked myself whether all the above facts cannot be grouped together in a working hypothesis which assumes that in the reversing layers of the sun and stars various degrees of "celestial dissociation" are at work, which dissociation prevents the coming together of the atoms which, at the temperature of the earth and at all artificial temperatures yet attained here, compose the metals, the metalloids, and compounds.

On this working hypothesis, the so-called elements not present in the reversing layer of a star will be in course of formation in the coronal atmosphere and in course of destruction as their vapour-densities carry them down; and their absorption will not only be small in consequence of the reduced pressure of that region, but what absorption there is will probably be limited wholly or in great part to the invisible violet end of the spectrum in the case of such bodies as the pure gases and their combinations, and chlorine. (See *I. ante*.)

The spectroscopic evidence as to what may be called the plasticity of the molecules of the metalloids, including of course oxygen and nitrogen, but excluding hydrogen, is so overwhelming, that even the absorption of iodine, although generally it is transparent to violet light, may (as I have found in a repetition of Dr. Andrews' experiments on the dichroism of iodine, in which I observed the spectrum) in part be driven into the violet end of the spectrum, for iodine in a solution in water or alcohol at once gives up its ordinary absorption properties, and stops violet light.\*

A preliminary comparison of the ordinary absorption spectrum of a stratum of 6 ft. of chlorine renders it not improbable that chlorine at a low temperature is the cause of some of the Fraunhofer lines in the violet, although, as said before, I have not yet obtained certain evidence as to the reversal of the bright lines of chlorine seen in the jar-spark.

There is also an apparent coincidence between some of the faint Fraunhofer lines and some of the lines of the low temperature absorption-spectrum of iodine.

Should subsequent researches strengthen the probability of this

\* Potassium has since been added.

\* I have since obtained the same result by observing the absorption of I vapour in a white-hot tube.

working hypothesis, it seems possible that iron meteorites will be associated with the metallic stars and stony meteorites with metalloidal and compound stars. Of the iron group of metals in the sun, iron and nickel are those which exist in greatest quantity, as I have determined from the number of lines reversed. Other striking facts, such as the presence of hydrogen in meteorites, might also be referred to.

An interesting physical speculation connected with this working hypothesis is the effect on the period of duration of a star's heat which would be brought about by assuming that the original atoms of which a star is composed are possessed with the increased potential energy of combination which this hypothesis endows them with. From the earliest phase of a star's life the dissipation of energy would, as it were, bring into play a new supply of heat, and so prolong the star's light.

May it not also be that if chemists take up this question which has arisen from the spectroscopic evidence of what I have before termed the plasticity of the molecules of the metalloids taken as a whole, much of the power of variation which is at present accorded to metals may be traced home to the metalloids? I need only refer to the fact that, so far as I can learn, all so-called changes of atomicity take place when metalloids are involved, and not when metals alone are in question.

As instances of these, I may refer to the triatomic combinations formed with chlorine, oxygen, sulphur, &c. in the case of tetrad or hexad metals.

May we not from these ideas be justified in defining a metal, provisionally, as a substance, the absorption-spectrum of which is generally the same as the radiation-spectrum, while the metalloids are substances the absorption-spectrum of which, generally, is not the same? In other words, in passing from a cold to a comparatively hot state, the plasticity of these latter comes into play, and we get a new molecular arrangement. Hence are we not justified in asking whether the change from oxygen to ozone is but a type of what takes place in all metalloids?

My best thanks are due to Mr. R. J. Friswell for the valuable aid he has afforded me in these investigations.

J. NORMAN LOCKYER

### SCIENTIFIC SERIALS

*Poggendorff's Annalen der Physik und Chemie*, 1874, No. 12.—This number completes vol. 153 of the series, and contains the following papers:—On the capacity of liquids for conducting heat, by A. Winkelman; account of experiments based upon the same method which Stefan employed successfully for determining the heat-conducting capacity of air, and results tabulated for water, alcohol, bisulphide of carbon, glycerine, and solutions of chlorides of potassium and sodium.—On the elastic after-effects in torsion motions, by F. Neesen.—Experimental researches on the behaviour of non-conducting bodies under the influence of electric forces, by Ludwig Boltzmann. The author starts from the correct supposition that, according to the theories of Clausius, Maxwell, and Helmholtz on the behaviour of dielectric non-conductors in the electric field, the remarkable yet obvious consequence results (which seems to have been overlooked hitherto), that electric forces must necessarily exercise perceptible attraction upon non-conductors simply on account of their dielectric polarisation. The results he obtained were quite in correspondence with the theories his experiments were based upon.—On the action of electrophora, by P. Riess.—Critical remarks on electro-dynamics, by H. Helmholtz.—On the power of conducting electric currents in metallic sulphides, by Ferdinand Braun. This paper is a supplement to another one by Herr Herwig (vol. 153, No 9, of these *Annals*), on the behaviour of iron and steel rods in galvanic currents.—On the reflection of light from the two surfaces of a lens, by Dr. Krebs. It is a well-known fact, that when light passes through a lens and we neglect the absorption in the interior of the lens itself, a certain quantity of light is reflected by the surfaces of the lens. Dr. Krebs for the first time gives a mathematical account of this phenomenon.—On the apparent place of a luminous point situated in a denser transparent medium, or that observed through a so-called plane-parallel plate, by K. L. Bauer. The author arrives at the conclusion that in most works on physics, and especially on optics, misrepresentations of the point in question are contained, and quotes as examples the works of Moisson, Willner, Crüger, Müller, Riedel, Schabus, Krebs, Frick, Banitz, Weinhold, and Jochmann; the only praiseworthy exception he found was Harting's excellent work on the microscope.—On some new sulphur salts,

by R. Schneider (tenth paper). The new salts mentioned in this paper are a compound of the formula—

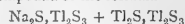

and another one of the formula  $\text{Ti}_2\text{S}_5$ .—On a new eye-piece, by Dr. H. Krüss. The author points out that the latest improvements in optical instruments generally applied to object-glasses, and that the eye-pieces remained where Huyghens and Ramsden left them; he therefore directed his attention to the improvement of eye-pieces, which he describes. Whether these improvements will answer their purpose, practical experiments only can show.—A note, by G. Wiedemann, on the dissociation of salts containing water. Mr. Wiedemann claims priority with regard to the investigations of M. Debray (*Comptes Rendus*, t. 66, p. 194, 1868).—A note on the theory of electricity, by E. Edlund.—A note by F. Lippich, on an electro-dynamic experiment of F. Zoellner, described in these *Annals*, vol. 153, p. 138.—A note by O. E. Meyer, on a paper by Dr. G. Baumgartner, on the influence of temperature upon the velocity of effluence of water flowing from tubes (these *Annals*, vol. 153, p. 44).—A note by H. Baumbauer, on a paper of Dr. F. Exner, on the solution-figures upon the surfaces of crystals (these *Annals*, vol. 153, p. 53). Mr. Baumbauer points out that these figures are quite independent of the crystallographic construction of the substances undergoing solution.—On the rays of light which decompose the xanthophyll of plants, by J. Wiesner. Finally, A. Gavalovski describes a self-acting mercury valve for shutting off gases, and preventing their passage in any but the desired direction.

THE *Journal of the Chemical Society* for January contains the following papers:—Action of bromine in presence of water on bromo-pyrogallol and on bromo-pyrocatechin, by Dr. J. Stenhouse. The action of bromine on pyrogallol gives rise to the formation of a yellow crystalline body of the formula  $\text{C}_{18}\text{H}_4\text{Br}_{14}\text{O}_6$  in accordance with the equation—

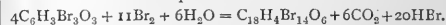

The author has not been able to determine the constitution of this body, but proposes to name it provisionally *xanthogallol*. Alkalies act upon xanthogallol in presence of ether in the following manner:—

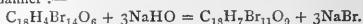

The excess of alkali at the same time reacts with the substance and forms an alkaline salt. The action of bromine and water on bromo-pyrocatechin gives rise to a crimson crystalline compound of the formula  $\text{C}_{18}\text{H}_2\text{Br}_{10}\text{O}_6$ , which the author has named provisionally *erythro-pyrocatechin*. This body is formed as follows:—

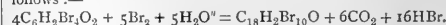

The next paper is by the same author, on the action of bromine on protocatechuic acid, gallic acid, and tannin. When protocatechuic acid is heated with excess of bromine in sealed tubes at  $100^\circ$  tetrabromopyrocatechin is produced, in accordance with the reaction—



The protocatechuic acid used was prepared from East Indian kino. Gallic acid heated with bromine to  $100^\circ$  gives rise to the formation of tribromopyrogallol,  $\text{C}_6\text{H}_3\text{Br}_3\text{O}_3$ . The reaction in the case of tannin is different according as the substance is perfectly dry or contains water. The action of chlorine on protocatechuic acid and on pyrogallol has likewise been studied.—On propionic coumarin and some of its derivatives, by W. H. Perkin. The author prepares this body by the action of propionic aldehyde on sodium-salicyl hydride.  $\beta$ -bromopropionic coumarin has been prepared by substituting sodium-bromosalicyl hydride for sodium-salicyl hydride in the preparation of propionic coumarin. The same body is produced by the action of bromine in excess on propionic coumarin. By the further action of bromine (dissolved in CS<sub>2</sub>) in a sealed tube heated to  $150^\circ$ ,  $\beta$ -dibromopropionic coumarin is produced. Fuming sulphuric acid dissolves propionic coumarin with the formation of a sulpho-acid of the formula  $\text{C}_{20}\text{H}_{16}\text{O}_4\text{S}_2\text{O}_6$ .—Action of the organic acids and their anhydrides on the natural alkaloids, Part II.: Butyryl and benzoyl derivatives of morphine and codeine, by G. H. Beckett and Dr. C. R. A. Wright. The action of butyric acid on codeine gives rise to the formation of dibutyryl-codeine,  $\text{C}_{25}\text{H}_{40}(\text{C}_4\text{H}_7\text{O}_2)_2\text{N}_2\text{O}_6$ . Butyric aldehyde yields the same body when heated with codeine. When morphine is substituted for codeine, an analogous compound,



dituberyl morphine,  $C_{34}H_{36}(C_4H_7O)_2N_2O_6$ , is formed, and at the same time a non-crystalline base isomeric with this latter body is produced. Butyric anhydride heated with morphine forms a dituberyl derivative, which is decomposed on long-continued boiling with water into the dituberyl derivative. The authors next treat of acetyl-butyl-morphine, obtained by heating the alkaloid with a mixture of the acids. Benzoic anhydride gives with codeine a di-derivative, and with morphine a tetra-derivative, which is decomposed by water into dibenzoyl-morphine. Benzoic acid gives, with morphine, an  $\alpha$ -di-derivative. The action of benzoic anhydride on  $\alpha$ -diacetyl-morphine has been studied, and likewise the action of benzoic and acetic anhydrides on tetra-acetyl-morphine and on tetra-benzoyl-morphine.—The last paper communicated to the Society in the present number is by E. A. Parnell, on the use of potassium permanganate in volumetric analysis, and on the estimation of iron in iron ores.

*Gazzetta Chimica Italiana*, fascicolo ix. and x.—These parts contain the following papers:—On the dilatation of phosphorus, by G. Pisati and G. de Franchi; Action of sulphur on water and on calcium carbonate, by Brugnatelli and Felleggio; Researches on the nature and constitution of tannic acid, by Hugo Schiff; Refractive indices of cyrene, benzene, and of some derivatives of natural and synthetical thymol, by G. Pisati and E. Paterno. A. Casali contributes a paper on chrome green. Search for amylic alcohol in spirits of wine, by C. Bettelli. J. Macagno describes a volumetric process for determining phosphoric acid.—The concluding paper is by Grassi, on the fermentation of must.—The part contains also a number of abstracts of papers published in other journals.

*Memorie della Società degli Spettroscopisti Italiani*, November 1874.—This number contains a discussion of the coincidence of the lines in the spectrum of Jupiter with that of our atmosphere, by Father Secchi, in which he appears to disagree with the conclusions arrived at by Vogel as to the coincidence of the lines and the brightness of the same.—The same author contributes a note on the comparison of the spectra of the compounds of carbon with the spectrum of Coggia's Comet; and for reasons given by him he considers the spectrum of the oxides of carbon best correspond to that of the comet; and further, he considers one of the spectra of the electric arc most similar, for he has observed two spectra superposed when viewing that arc. On examining the spectrum of the comet with a polariscope the continuous spectrum disappeared, leaving only that of the bands, proving apparently that the continuous spectrum is reflected light only. Drawings of the chromosphere for July, August, September, October, and November, by Secchi, accompany this number.

## SOCIETIES AND ACADEMIES

### LONDON

Royal Society, Feb. 11.—“On the Structure and Development of *Myriothele*,” by Prof. Allman.

The endoderm of the body is shown to be composed of numerous layers of large spherical cells of clear protoplasm. Externally it is continued in an altered form into the tentacles, while internally it forms long thick villus-like processes which project into the cavity of the body.

Interposed between the endoderm and the ectoderm is the *fibriated layer*. It consists of longitudinal muscular fibrille, closely adherent to the outer surface of a structureless hyaline membrane—the “*Stützlamelle*” of Reichert.

The *ectoderm* is composed of small round cells containing yellowish granules. Among these the thread-cells may be seen, lying chiefly near the outer surface of the body.

The deeper part of the ectoderm consists of cells, each of which is prolonged into a tail-like process, so that they assume a claviform shape.

The male and female sporosacs are borne by the trophosome. The generative elements, whether male or female, originate in a special cavity (gonogenetic chamber), which is formed in the substance of the endoderm of the sporosac.

Immediately after its expulsion it is seized by the sucker-like extremities of certain remarkable organs (claspers), which are developed among the blastostyles and resemble long filiform and very contractile tentacles.

The actinoid, on its escape from its capsule, is provided not

only with long arms but with short scattered clavate tentacles. The short clavate tentacles become the permanent tentacles of the fully developed hydroid; the long arms, on the other hand, are purely embryonic and transitory.

The long embryonic arms originate in the spheroidal *Planula*. They are formed by a true invagination, and at first grow inwards into the body-cavity of the *Planula*. It is only just before the escape of the actinoid from its capsule that they evaginate themselves and become external.

After enjoying for one or two days its free existence, during which it moves about by the aid of its long arms, the embryo fixes itself by its proximal end, the long arms gradually disappear, the short permanent tentacles increase in number, and the essential form of the adult is soon acquired.

Linnean Society, Feb. 18.—Dr. G. J. Allman, F.R.S., president, in the chair.—The following papers were read:—On the structure, affinities, and probable source of the large Human Fluke, *Distoma crassum*, Busk, by Dr. T. S. Cobbold, F.R.S. The author commenced by recording all the facts he could gather respecting the original discovery of the parasite by Prof. Busk, dwelling especially on the circumstance that an interval of thirty years had elapsed since the first examples were made known to science. He next referred to other singular instances of the supposed rarity of certain human helminths, adding the cases of *Tania nana* and *Distoma heterophyes*; and he also remarked upon the long lapse of time occurring between the periods of discovery and verification of particular species of Entozoa, instancing the cases of *Stephanurus dentatus* and *Distoma conjunctum*. He was indebted to Dr. George Johnson, F.R.S., for having brought the new hosts on bearers of *Distoma crassum* under his observation. The patients, a missionary and his wife, had been four years resident in China, most of their time being spent at Ningpo, where they had partaken freely of fish, oysters, and salads. The author of the paper had secured seven parasites, two from the lady and five from her husband. Only two of the seven specimens supplied him with such new facts as he had been able to make out in respect of the organisation of the animal. The only example which gave the best results Dr. Cobbold had since deposited in the University Museum at Oxford (Prof. Rolleston's department). He found the vitelline glands to be largely developed, and he believed that in place of there being two testes, as had hitherto been conjectured, there was only one large compound gland, with remarkably large and conspicuous seminal ducts. These ducts were well seen in the dried specimen exhibited to the Society. The hitherto supposed ovary testis turned out to be the ovary, and there was a special and smaller organ in front of the ovary which he regarded as an unusually developed shell-gland. The intestinal tubes are simple and unbranched, but on the other hand the uterine organ appeared not to consist of a single continuous tube, but to be partly branched, as obtains in *D. lanceolatum*, and in some other less known flukes. The remainder of the communication was taken up with remarks on the affinities of the parasite, and with a brief *résumé* of the hitherto known facts of trematode development, in so far as they tended to throw light on the source of *Distoma crassum*. In particular he referred to the labours of Mr. Moseley in connection with the land planarians of Ceylon, to the contributions of Giard, Claparède, Pagenstecher, and others in respect of *Bucephalus*, and to the still more recent discoveries of Dr. Ernst Zeller as regards the destiny of *Leucochloridium*. From a general review of all the data thus obtained, Dr. Cobbold believed that the *Distoma crassum* had been obtained by the consumption, on the part of the missionary and his wife, either of Ningpo oysters or of fish insufficiently cooked. After the reading of the paper Mr. G. Busk and Dr. G. Johnson added a few more facts respecting the parasite.—On the external anatomy of *Tania vittatus*, by Dr. M'Donald.

Mathematical Society, Feb. 11.—Prof. H. J. S. Smith, F.R.S., president, in the chair.—Prof. Cayley communicated two short notes: on a point in the theory of attractions, and on the question of the mechanical description of a quartic curve.—Prof. Sylvester exhibited a new sort of lady's fan, and briefly indicated its mode of construction and properties. With the fan it is possible to divide any angle into any assigned equal number of parts, and the trajectories of points taken in the several links connecting together the sticks of the fan have finite nodes whose numbers are successively, 1, 2<sup>2</sup>, 3<sup>2</sup>, 4<sup>2</sup>. . . . He then dwelt in detail on the expression of the curves generated by any given system whatever of linkwork under the form of an irreducible determinant. The author stated: That parallel motions exist at

all is a paradox more wonderful than ever, now that his method gives the means of determining the conditions to be satisfied and comparing their number with that of the disposable constants. The orders for 3, 5, 7 bars are 6, 20, 72. Formerly the existence of *one* was doubted; now a finite number for every order of link-work is rendered highly probable.—The Secretary then read portions of papers by Rev. W. H. Lavery, Mr. E. J. Routh, F.R.S., and Mr. J. Griffiths. Mr. Lavery's paper discussed a particular case of Peaucellier's problem. Mr. Routh discussed Laplace's problem of three particles. Laplace showed that if three particles be placed at the corners of an equilateral triangle and be properly projected, they will move under their mutual attractions so as always to remain at the angular points of an equilateral triangle. On the supposition that the law of attraction is the inverse *k*th power of the distance, Mr. Routh arrives at the following results:—1. The motion cannot be stable unless *k* is less than 3. 2. The motion is stable, whatever the masses may be, if the law of force be expressed by any positive power of the distance, or any negative power less than unity. For other powers the stability will depend on the relation between the masses. 3. The motion is stable to a first approximation if  $\frac{(M+m+m')^2}{Mm+Mm'+mm'} > 3 \left( \frac{1+k}{3-k} \right)^2$  where *M, m, m'* are the masses. This agrees with a result given by M. Gascheau (in a paper not seen by the author), if *k* = 2, or the law of force be the law of nature. 4. When two of the masses are much smaller than the third, the inequality in their angular distances, as seen from the large body, has a much greater coefficient than their linear distances from the same body. 5. On proceeding to a second approximation it would seem that the form of the triangle joining the three particles is very little altered by any disturbance, but in certain cases, depending on the nature of the disturbance, the size of the triangle may be subject to very considerable variations. As a supplement, Mr. Routh generalises the reasoning of the problem of the three bodies so as to obtain the form of the determinantal equation to find the periods of oscillation of any dynamical system about a state of steady motion in which the *vis viva* is constant. Two limitations are made: first, the system must be under a conservative system of forces; and, secondly, the *vis viva* can be expressed in terms of the co-ordinates, so as not to contain the time explicitly. The equation is then shown to be always of an *even* order, and the condition of stability is that all the roots should be real and negative.—The results arrived at in Mr. Griffiths' note on some relations between certain elliptic and hyperbolic functions may be thus stated:—Let *E, F, H* stand for the integrals

$$\int \sqrt{1 - e^2 \sin^2 \theta} d\theta, \quad \int \sqrt{1 - e^2 \sin^2 \theta}$$

$$\int \sqrt{e'^2 \operatorname{cosec}^2 \theta - 1} \operatorname{cosec} \theta d\theta$$

respectively, the limits in each case being  $\theta_0$  to  $\theta$ , and  $e' = 1$ , then

$$eH + E - (1 - e^2)F + \left( \sqrt{1 - e^2 \sin^2 \theta} \cot \theta \right)_{\theta_0}^{\theta} = 0$$

and

$$\frac{E + E'}{H + H'} = e^2 \sin \theta \sin \phi \sin \theta_0 \sin \phi_0$$

where the limits in *E', H'* are  $\phi_0$  to  $\phi$ , determined from the equation—

$$\cos \theta \cos \phi - \sin \theta \sin \phi \sqrt{1 - e^2 \sin^2 \mu} = \cos \mu$$

$$= \cos \theta_0 \cos \phi_0 - \sin \theta_0 \sin \phi_0 \sqrt{1 - e^2 \sin^2 \mu}$$

$\mu$  being a constant.

Geological Society, Feb. 10.—Mr. John Evans, F.R.S., president, in the chair.—The following communications were read:—The phosphorite deposits of North Wales, by Mr. D. C. Davies. The deposit of phosphate of lime described by the author is a bed varying from ten to fifteen inches in thickness, which occurs at the top of the Bala limestone over a considerable district in North Wales, having been detected in various localities from Llanyllin to the hills north and west of Dinas Mawddly. The bed is rendered black by the presence of graphite, and appears to consist of concretions of various sizes cemented together by a black matrix. The concretions are richest in phosphate of lime, some of them containing 64 per cent.; the average amount in the bed, including the matrix, is 46 per cent. The deposit is underlain by a bed of crystalline

limestone, and sometimes divided by thin beds of similar limestone into two or three layers. The author noticed the principal fossils occurring in the Bala limestone below the phosphorite beds, and stated that many of those in the overlying shales, up to a certain distance above the bed, are phosphatised. The author referred to the presence of phosphate of lime in the inner layers of *Unio* and *Anodonta* to the amount of as much as 15 per cent., and thought that the phosphate of lime in the deposit was probably of organic origin. It may have been an old sea-bottom on which the phosphate of lime of *Mollusca* and *Crustacea* was accumulated during a long period, and seaweeds may also have contributed their share. It probably represented the remains of an ancient Laminarian zone. The author suggested that the phosphatic nodules of the so-called coprolite beds in other parts of England might have been derived from the denudation of similar deposits.—On the bone-caves in the neighbourhood of Castleton, Derbyshire, by Rooke Pennington, LL.B.; communicated by Prof. W. Boyd Dawkins, F.R.S. The author described as a prehistoric cave the Cave Dale Cave, situated in Cave Dale, just below the keep of Peveril Castle. The upper earth in this cave contained fragments of late pottery mixed up (by rabbits) with bits of rude prehistoric pottery, a tined piece of stag's horn, an iron spike, two worked flints, a piece of jet, part of a bone comb, and a bronze celt of peculiar form, many bones of *Bos longifrons* and goat, broken to get out the marrow, and remains of hogs; charcoal and human teeth also attested the occupation of the cave by man. There were also remains of fox, badger, cat, water-rat, dog, red deer, duck, fowl, and hare. Lower down were remains of *Bos longifrons*, hog, red deer, wolf, and horse; and lower still, next the rock, more human teeth, remains of animals, and a good flint. The cave seemed to have been occupied from time to time during a lengthened period, probably from the Neolithic age into those of bronze and iron. A cave in Gelly or Hartle Dale contained, in blackish mould, bones (some broken) of goat, pig, fox, and rabbit, and pieces of very rude prehistoric pottery. Of Pleistocene caves and fissures the author described several. One in Hartle Dale furnished remains of rhinoceros, aurochs (*Bison prisus*), and mammoth, lying in yellow earth. The bones were probably carried in by water. A fissure near the village of Waterhouses, in Staffordshire, is six feet wide, and filled with the ordinary loam. Bones of mammoths and the skeleton of a young bison have been obtained from it, and the author supposes the animals to have fallen into the fissure while making for the river to drink. The Windy Knoll fissure is situated near Castleton, in a quarry near the top of the Winnetts, and close to the most northern boundary of the mountain limestone of Derbyshire. The author described particularly the situation of this fissure and drainage of the district in which it is situated. The fissure itself is filled with the ordinary loam, containing fragments of limestone, and enclosing an astonishing quantity of bones of animals confusedly mixed together, those lowest down near the rocks being coated with and sometimes united by stalagmite. The author supposes that this was a swampy place into which animals fell from time to time, and in rainy seasons their remains might be washed into it from the neighbouring slopes.—The Mammalia found at Windy Knoll, by Prof. W. Boyd Dawkins, F.R.S. This paper contained an enumeration of the remains of Mammalia found in the Windy Knoll fissure described by Mr. Pennington. They were stated to belong to the following species: bison, reindeer, grisly bear, wolf, fox, hare, rabbit, and water-rat. Great quantities of bones and teeth were found, the number of individuals represented by the remains being given roughly by the author as follows:—

Bison	...	...	...	...	40-60
Reindeer	...	...	...	...	20-30
Grisly bear	...	...	...	...	4-5
Wolf	...	...	...	...	7

From the great excess of herbivorous forms, and the position of the fissure, the author assumed that the latter lay in the line of the annual migrations of the bison and reindeer, during which some individuals might fall in; and he explained the presence of the carnivores by their having followed the migratory herds in order to prey upon stragglers, as is now the case with the reindeer in Siberia and the bison in North America. He further showed, from the examination of the young teeth of the bison and the reindeer, that these animals must have passed this way at different seasons of the year, and indicated that the deposit must be regarded as of Pleistocene age, though whether pre- or post-glacial is an open question.

**Meteorological Society, Feb. 17.**—Dr. R. J. Mann, F.R.A.S., president, in the chair.—The following communications were read:—Report of the Conference on the Registration of Phenological Phenomena. The Council of the Society resolved during last session that it was expedient that observations of natural phenomena connected with the return of the seasons, as well as of such branches of physical inquiry as tend to establish a connection between meteorological agencies and the development of vegetable life, should be organised on a more systematic and scientific basis than heretofore. Application was made to other societies interested in the matter to nominate delegates to form a committee for the purpose of drafting complete instructions and organising in an efficient manner this branch of investigation. Delegates were appointed by the Royal Agricultural, Royal Horticultural, Royal Botanic, Royal Dublin, Marlborough College Natural History, and the Meteorological Societies; and meetings of this joint committee have been held, when the subject was fully discussed, and reports, prepared by the Rev. T. A. Preston, M.A., and Prof. T. Dyer, F.L.S., on plants; Mr. McLachlan, F.L.S., on insects, and Prof. A. Newton, F.R.S., on birds, were adopted.—On the weather of thirteen summers, by R. Strachan, F.M.S. This paper is in continuation of others read before the Society on the different seasons of the year.—On a universal system of meteorography, by Prof. Van Ryselberghe. This paper gave a description of a recording apparatus by means of which the indications of a great number of meteorological instruments of any kind can be registered, whether they are placed near to or far from it, so that simultaneous readings of several instruments at various distant stations can be recorded at a central observatory. The chief feature in this recorder is, that it engraves automatically on metal the different curves, thus furnishing a plate graduated by the apparatus itself, from which as many copies as may be desired can be struck off. Another feature is, that a single burin, put in motion by a simple electro-magnet, can engrave successively, on the same metallic plate, the elements of all the curves.

**Zoological Society, Feb. 16.**—Mr. George Busk, F.R.S., vice-president, in the chair.—Dr. Sclater exhibited a drawing of a supposed new Rhinoceros from the Terai of Bhootan, which had been forwarded to him from Calcutta, by Mr. W. Jamrach, who had the animal there alive, and intended bringing it to England.—Mr. Sclater exhibited and made remarks on a living specimen of the Peguan Tree Shrew (*Tupaia peguana*), which had been presented to the Society by the Hon. Ashley Eden, Chief Commissioner at Rangoon, British Burmah. This was believed to be the first specimen of a living *Tupaia* of any species that had reached Europe.—Mr. A. H. Garrod read a paper on a point in the mechanism of the bird's wing, which renders it so specially adapted for flight.—Mr. Sclater read remarks on the Cassowaries now living in the Society's Gardens, amongst which were representatives of five different species. One of them from the south of New Guinea was believed to be new to science, and proposed to be called *C. picticollis*. Mr. Sclater also gave notice of a new Cassowary obtained in the Aroo Islands by Signor Beccari, and transmitted to the Museo Civico of Genoa, which he proposed to call *Cassuaris beccarii*.—Prof. Owen, C.B., communicated a note on the discovery of the remains of various species of *Diornis* in the province of Otago, New Zealand.—Mr. Edward R. Alston read a paper on *Anomalurus*, its structure and position, in which he came to the conclusion that this peculiar form of Rodents should be either referred to the Sciurine group of Rodents as a distinct sub-family, or placed next to it as a separate family—*Anomaluridae*.—Mr. H. E. Dresser read some notes on the nest and eggs of *Hypolais caligata*, and on the egg of *Charadrius asiaticus*, and made remarks on the latter species, and on *Charadrius veredus*.—Mr. R. Bowdler-Sharpe communicated a paper on the birds of Labuan, in which was given an account of a collection made in that island by Mr. John Low.

**Entomological Society, Feb. 1.**—Sir Sidney Smith Saunders, C.M.G., president, in the chair.—Mr. Stevens exhibited a variety of *Noctua glaucoxa*, and Mr. Champion some specimens of *Amara continua*, a species recently detected in this country.—Mr. Herbert Druce exhibited a fine collection of *Rhopalocera* recently received from Santarem.—The President exhibited a nest of *Polistes gallica* taken on the esplanade at Corfu, of which the cells were partly constructed with coloured paper taken from some playbills posted in the vicinity, as alluded to in his anniversary address delivered at the last meeting.—Mr. Smith remarked on *Colletes*

*curvicauda* having been found a few years ago in the Isle of Wight and in Liverpool. In 1873 he had transported some specimens from the latter locality to Shirley Common, and he had reason to believe that he had succeeded in establishing a colony there, as the insect had been taken near the spot in 1874 by Mr. d'Arcy Power.—A paper was communicated by Mr. A. G. Butler on the *Rhopalocera* of Australia.—A paper was read by Mr. W. Arnold Lewis on "Entomological Nomenclature and the Rule of Priority."—The President nominated Messrs. Dunning, Pascoe, and Weir as vice-presidents for the ensuing year.

**Feb. 15.**—Sir Sidney Smith Saunders, C.M.G., president, in the chair.—Mr. Phipson exhibited a singular variety of *Strenia clathrata* from Basingstoke, the wings being nearly unicolorous.—Mr. F. Smith exhibited a second collection of *Hymenoptera* from Mr. Rothney, of Calcutta, containing 1,573 specimens, all in the finest condition. There were probably not more than twenty-five undescribed species, but from twenty to thirty species (which were hitherto represented in the British Museum by a single sex) were here represented by both sexes.—Mr. Verrall exhibited some living fleas taken two days previously from inside the ears of a rabbit near Lewes. They were gregarious in this situation, and in such a position that the animal was unable to dislodge them by scratching. He alluded to a communication made to him by Mr. M'Lachlan regarding a species from Ceylon which was gregariously collected in a very limited space on the neck of a fowl, and which had been exhibited at a recent meeting of the Microscopical Society. They were affixed to the skin of the fowl by the proboscis, so that only the tails were visible outwards. Mr. Cole said he had found fleas in a hedgehog, and Mr. W. Arnold Lewis had observed a species in a marmot in Switzerland.—Mr. Dunning called attention to a recent extract from a French paper in which it was stated that a paint could be manufactured from cockchafer.—The Rev. R. P. Murray stated that Mr. Edwards, of Virginia, was very desirous of obtaining pupae of *Pieris napi*.

**Royal Geographical Society, Feb. 22.**—Sir H. Rawlinson presided.—A paper was read by Capt. J. Moresby, giving an interesting commercial, political, and geographical description of discoveries in Eastern New Guinea, made by himself and the officers of her Majesty's ship *Basilisk* during a recent voyage, undertaken to substantiate and follow up a previous similar exploration. The practical outcome appears to have been the establishment of the fact that the D'Entrecasteaux group of islands, sighted ninety-four years ago, consists of three large islands, separated from each other and the main land of New Guinea by narrow straits. These islands the captain and his crew were the first to visit and survey, and it may be said they are now politically appropriated in the British interest. The captain has named the islands Normanby, Ferguson, and Goodenough; while he calls the straits Ward Hunt, Goschen, Dawson, and Moresby. These islands, he states, extend north and south about ninety miles, and afford harbour and anchorage.

**Institution of Civil Engineers, Feb. 16.**—Mr. Thos. E. Harrison, president, in the chair. The paper read was on the erosion of the bore in heavy guns, and the means for its prevention, with suggestions for the improvement of muzzle-loading projectiles, by Mr. C. W. Lancaster, Assoc. Inst. C.E.

## CAMBRIDGE

**Philosophical Society, Feb. 8.**—The following communication was made:—On the centre of motion of the eye, by Prof. Clerk-Maxwell. The series of positions which the eye assumes as it is rolled horizontally have been investigated by Donders (Donders and Doijer, *Derde Jaarlijcksch Verslag betr. het Nederlandsch Gasthuis voor Oogtijders*; Utrecht, 1862), and recently by Mr. J. L. Tupper (Proc. R.S., June 18, 1874). The chief difficulty in the investigation consists in fixing the head while the eyeball moves. The only satisfactory method of obtaining a system of co-ordinates fixed with reference to the skull is that adopted by Helmholtz (*Handbuch der Physiologischen Optik*, p. 517), and described in his Croonian Lecture. A piece of wood, part of the upper surface of which is covered with warm sealing-wax, is placed between the teeth and bitten hard till the sealing-wax sets and forms a cast of the upper teeth. By inserting the teeth into their proper holes in the sealing-wax the piece of wood may at any time be placed in a determinate position relatively to the skull. By this device of Helmholtz the patient is relieved from the pressure of screws and clamps applied to the skin of his head, and he becomes free to move his head as he likes, pro-

vided he keeps the piece of wood between his teeth. If we can now adjust another piece of wood so that it shall always have a determinate position with respect to the eyeball, we may study the motion of the one piece of wood with respect to the other as the eye moves about. For this purpose a small mirror is fixed to a board, and a dot is marked on the mirror. If the eye, looking straight at the image of its own pupil in the mirror, sees the dot in the centre of the pupil, the normal to the mirror through the dot is the visual axis of the eye—a determinate line. A right-angled prism is fixed to the board near the eye in such a position that the eye sees the image of its own cornea in profile by reflection, first at the prism, and then at the mirror. A vertical line is drawn with black sealing-wax on the surface of the prism next the eye, and the board is moved towards or from the eye till this line appears as a tangent to the front of the cornea, while the dot still is seen to cover the centre of the image of the pupil. The only way in which the position of the board can now vary with respect to the eye is by turning round the line of vision as an axis, and this is prevented by the board being laid on a horizontal platform carried by the teeth. If now the eye is brought into two different positions and the board moved on the platform, so as to be always in the same position relative to the eye, we have to find the centre about which the board might have turned so as to get from one position to the other. For this purpose two holes are made in the platform, and a needle thrust through the holes is made to prick a card fastened to the upper board. We thus obtain two pairs of points, *AB* for the first position, and *ab* for the second. The ordinary rule for determining the centre of motion is to draw lines bisecting *Aa* and *Bb* at right angles. The intersection of these is the centre of motion. This construction fails when the centre of motion is in or near the line *AB*, for then the two lines coincide. In this case we may produce *AB* and *ab* till they meet, and draw a line bisecting the angle externally. This line will pass through the centre of motion as well as the other two, and when they coincide it intersects them at right angles.

MANCHESTER

Literary and Philosophical Society, Feb. 2.—Mr. Alfred Brothers, F.R.A.S., president of the section, in the chair.—Results of meteorological observations taken at Langdale, Dumbula, Ceylon, in the year 1873, by Mr. Edward Heelis; communicated by Mr. Joseph Baxendy, F.R.A.S.

Feb. 9.—Mr. Edward Schunck, F.R.S., president, in the chair.—A method of finding the axes of an ellipse when two conjugate diameters are given, by Mr. J. B. Millar, B.E.; communicated by Prof. O. Reynolds.—Mr. E. W. Binney, F.R.S., V.P., presented to the Society a bust of the late James Wolfenden, of Hollinwood, one of the most noted mathematicians of the Lancashire school, who was born on the 22nd June, 1754, and died on the 29th March, 1841.

DUBLIN

Royal Irish Academy, Jan. 11.—William Stokes, F.R.S., president, in the chair.—The Secretary read a paper, by Mr. J. Rhys, of Rhyl, on Ogham inscriptions.—Dr. Edmund Davy read a paper on some newly observed properties possessed by certain salts of fulminic acid.—Dr. Doberck, astronomer at Col. Cooper's observatory, Markree, County Sligo, read a paper on the Comet I. of 1845.

Jan. 25.—William Stokes, F.R.S., president, in the chair.—The Rev. Edward M'Clure read a paper on Irish popular names.—Samuel Ferguson, LL.D., vice-president, read a paper on an Ogham inscription at Mullagh, Co. Cavan; also notices of the Monattagart Ogham texts, from the Bishop of Limerick, Whitley Stokes, LL.D., and Rev. R. D. Haigh.—Rev. Dr. Reeves, vice-president, read a paper on the MS. in Marsh's Library called the "Codex Kilkennensis."—Mr. H. W. Mackintosh read a paper on the structure of the spines in the Diademata.—Dr. A. Macalister read a paper on a few points in the cranial osteology of *Bradypus galuris*; also a paper on the anatomy of insectivorous Edentates, Part I.

PARIS

Academy of Sciences, Feb. 15.—M. M. Frémy in the chair.—The following papers were read:—New researches on the mode of intervention of electro-capillary forces in the phenomena of nutrition, by M. Becquerel.—On the depth and the superposition of magnetic layers in steel, by M. J. Jamin.—M. Faye made some remarks on M. Jamin's paper.—M. de Lesseps then made a communication relative to the question of unification of the tonnage of vessels; after which

M. Dupuy de Lome made some remarks on the same.—Experiments on the absorption by the root of plants of the red juice of *Phytolacca decandra*, by M. H. Bailion. These experiments are in continuance of those made by Biot, De la Baisse, and Unger.—On the defective notes of string instruments, by M. A. Dien. This paper has special reference to the violin and violoncello, and treats of those harsh and buzzing notes commonly known by musicians as the *wolf*.—On the presence and the formation of *vibriones* in the pus from abscesses, by M. Albert Bergeron; researches made at the Charité Hospital, in Paris, in pursuance of M. Gosselin's paper read at the meeting of Jan. 11 (NATURE, vol. xi., page 240).—On a dissemination apparatus of *Gregarina* and *Stylorhynchus*, and a remarkable phase of sporulation in the latter genus, by M. A. Schneider.—A memoir, by M. Ch. Antoine, on some mechanical properties of saturated steam.—A memoir, by M. A. Picard, on a new method to establish the equations of elasticity of solid bodies.—A note by M. M. Girard on the influence of cold temperatures upon *Phylloxera*, showing that these insects are not much affected by cold, and that it is useless to count upon their destruction by cold winters.—A note, by M. A. Demogot, on various improvements made upon Holtz's machine; these improvements ensure its perfect action even in the dampest weather.—The Secretary then read the following telegram received from M. Bouquet de la Grye, the chief of the expedition sent to Campbell to observe the Transit of Venus:—"Venus seen before ingress only; no contacts; all well." It is dated from San Francisco.—A note, by M. E. Rivière, on the quaternary deposits, superior to the ossiferous cavern of Nice, known as the superior cavern of Cuvier. The author considers that the red inferior deposit in the caverns of Mont-du-Chateau, of Nice, must be regarded as the true ossiferous breccia, and that the superior deposits were formed by accumulations of detrital matter. The animals whose bones originate from this deposit were contemporary to the human beings of which Cuvier described a jawbone.—On a case of dimorphism in the genus of Gramineæ, by M. E. Fournier.—On the discovery of true Batrachia in primary strata, by M. A. Gaudry.—On the discovery of a fossil species of *Bovide*, probably *Bubalus antiquus*, at Djelfa, Algeria, by M. P. Gervais. The same gentleman then showed some reproductions of flint implements found in the caves of Oussidan, near Tlemcen, Algeria.—A note by M. Chapelat, relative to a large bolide supposed to have been observed on the evening of Feb. 10. It was afterwards found that the supposed meteor was only the edge of a cloud brilliantly illuminated by the sun, which had already set.—A note, by M. de la Haye, on atmospheric electricity and the presence of hydrogen in the atmosphere.

BOOKS AND PAMPHLETS RECEIVED

AMERICAN.—Papers on Natural Erosion by Sand in the Western Territories; The Recency of certain Volcanoes of the Western United States; and the advantages of the Colorado Plateau Region as a Field for Geological Study; G. K. Gilbert (American Association for the Advancement of Science).—Report of the State Board of Education on the proposed Survey of the Commonwealth (Boston, Wright and Potter).—Monthly Report of the Department of Agriculture, Nov. and Dec. 1874 (Washington, U.S.)

CONTENTS

PAGE

A GERMAN MANUAL OF SCIENTIFIC INQUIRY . . . . .	321
THE SANDWICH ISLANDS ( <i>With Illustrations</i> ) . . . . .	322
OUR BOOK SHELF.— Dr. Hall's "Sun and Earth" . . . . .	324
LETTERS TO THE EDITOR:— On the Building up of the Tone in the "Gamba" Organ-pipe.— Dr. HERMANN SMITH . . . . .	325
Periodicity of Rainfall.—C. MELDRUM . . . . .	327
Ice-Caves.—Rev. T. G. DONNEY . . . . .	327
The Morse Code.—Prof. W. F. BARRETT . . . . .	328
The Micrographic Dictionary.—Pollen Grains.—W. G. SMITH . . . . .	328
OUR ASTRONOMICAL COLUMN:— ♃ and ♄ Retrials . . . . .	328
The Binary Star $\alpha$ Cassiopeæ . . . . .	328
The Binary Star $\alpha$ Centauri . . . . .	328
Red Stars . . . . .	328
Encke's Comet . . . . .	328
BEARING OF METEOROLOGICAL RECORDS ON A SUPPOSED CHANGE OF CLIMATE IN SCOTLAND. By ALEXANDER BUCHAN . . . . .	319
NATURAL PHENOMENA IN SOUTH AMERICA. By J. MUNRO ( <i>With Illustrations</i> ) . . . . .	329
THE BIRMINGHAM COLLEGE OF SCIENCE . . . . .	331
NOTES . . . . .	334
PRELIMINARY INQUIRY INTO THE EXISTENCE OF ELEMENTS IN THE SUN NOT PREVIOUSLY TRACED. By J. N. LOCKYER, F.R.S. . . . .	334
SCIENTIFIC SERIALS . . . . .	335
SOCIETIES AND ACADEMIES . . . . .	337
BOOKS AND PAMPHLETS RECEIVED . . . . .	340

THURSDAY, MARCH 4, 1875

SIR CHARLES LYELL, BART., F.R.S.

BORN NOV. 14, 1797; DIED FEB. 22, 1875.

LYELL'S life was uneventful. Great changes in thought, great scientific discoveries, are not called events. Yet, as might have been expected in the case of a man so active, so famous, so far travelled, his life was full of incident, and groups of incidents lead to or make up events. We are indeed in the habit of looking upon Sir Charles Lyell as representing an idea, a theory, a principle—and rightly so. We cannot say exactly that he originated a new method of investigation, but by the use of the right methods, and in the determination to follow fairly each established fact to its logical consequences, he has taught us the laws which have governed the changes of which we can observe the results in the crust of the earth.

We hear of him as a boy making a collection of insects in the New Forest, to which his father removed soon after he was born. At Oxford we find him studying under Buckland. When called to the bar we hear of him on circuit, but already known as a student of nature; for the story goes that he was often missed, and in reply to the question "Where's Lyell?" the answer was, "Oh! he's sure to be somewhere at the bottom of a well, seeking for truth."

The list of his various papers shows how much original work he did in the earlier part of his career: on the older and newer deposits of his native county, Forfarshire; on various beds in Hampshire; the results of observations as to earth movements and other phenomena in Scandinavia; on denudation and volcanoes in the Auvergne; many papers on the Tertiary deposits at home and abroad, and many on various parts of America. Sixteen years ago he published an elaborate memoir on Mount Etna; but latterly the result of his work has appeared in his larger books instead of in separate papers, and it is wonderful how far he was able to carry out his determination to verify on the ground all the observations upon which any important reasoning was founded.

No mind more quick to realise the bearing of the new facts continually being brought before it; no judgment more sound to decide whether the evidence was as yet sufficient. Hence, as work after work and edition after edition came out, the geological world turned anxiously to read his judgment on the vexed questions of the day, knowing that no prejudice would prevent his reversing his own former decision if new light had been thrown upon the subject. Doubtful inferences, which depended upon long inductions and incomplete evidence, were always given with such a clear statement of the sources of error still remaining, that many brilliant but too hasty generalisers complained of his tardy acceptance of their ingenious theories; but the public benefited by his caution and care.

There were many great workers and grand reasoners in the field of geological research when Lyell began his course. But his work did not clash with theirs. The chief of them were collecting evidence among the older rocks; Lyell's work was at first among the newer and, as we have seen, even among living forms of life. He at

first watched active or quite recent volcanoes, while others were searching among the older records of the rocks what really were the facts that had to be interpreted.

For the general question, most of those who had got beyond the Wernerian theory were contented to adopt the views of Hutton, with more or less stress laid upon the periodic catastrophes to destroy the old order of things and to bring new land surfaces within reach of the agencies which Hutton held would then gradually mould and carve them into the varying outlines of hill and valley.

But Lyell's line of investigation soon taught him that there were forces in action sufficient not only to chisel and carve the rocks when thrown up by unexplained convulsions, but that this successive bringing of portions of the earth's crust within reach of the graving tool was also part of the ordinary operations of nature.

This was, in fact, the true theory of evolution applied fully to the crust of the earth, and this paved the way for a rational explanation of the origin of species by Darwin, as the continuity of life is not consistent with the Huttonian theory of periodic interruptions of universal extent. Lyell pointed out that it was a matter of observation that variations occurred—variations of level, variations of texture, of hardness, or solubility—that a process of natural selection determined which should stand and which perish. He was at least as successful as the naturalist in giving a satisfactory reason for the occurrence of many of the variations by reference to observed surroundings and known laws. His views commended themselves to the judgment of thinking men, and Cuvier's "Theory of the Earth" was never reproduced in England after the appearance of Lyell's "Principles" in 1829-30. He steadily opposed the views of Lamarck, who explained the origin of species chiefly by some not very clearly defined adaptability in organic nature which enabled it to develop from time to time such varieties of structure as the changes of external circumstances required; much-used organs were strengthened and developed; unused organs were reduced to a rudimentary state. Lamarck's theory was the suggestion of a method by which results such as those observed might have been produced, but he did not show that it was one of the ordinary operations of nature to produce such results in that way. Therefore, the evidence brought forward by Lamarck being faulty, Lyell denied his conclusion, and opposed Lamarck's view as to the continuity of life. When, however, Darwin applied to natural history the methods which Lyell had long used to explain the phenomena of the crust of the earth, and again brought forward the theory of continuity of life, but explained it by variation and natural selection, Lyell accepted the conclusion because now founded on sound reasoning.

Darwin's theory of the evolution of life by the survival of the fittest holds, though we might possibly have to limit our application of it. Lamarck's notion of the development of new forms by dependent modification is not supported by sufficient direct evidence, even when we allow the continuity of life.

Lyell's claim to fame lies in this, that he organised the whole method of inquiry into the history of the formation of the crust of the earth, and established on a sound

footing the true principles of geological science; his theory being, that by the uniform action of forces such as are now in operation, the visible crust of the earth has been evolved from previous states.

Lyell was not only a keen investigator of natural phenomena; he was also a shrewd observer of human nature, and his four interesting volumes of travel in America are full of clever criticism and sagacious forecasts. His mind, always fresh and open to new impressions, by sympathy drew towards it and quickened the enthusiasm of all who studied nature. Had he done nothing himself, he would have helped science on by the warmth with which he hailed each new discovery. How many a young geologist has been braced up for new efforts by the encouraging words he heard from Sir Charles, and how many a one has felt exaggeration checked and the faculty of seeing things as they are strengthened by a conversation with that keen sifter of the true from the false!

Though by nature most sociable and genial, yet Sir Charles often withdrew from society where the object of his life, the pursuit of science, was not promoted; but when anything interesting turned up he always tried to share his pleasure with all around. Many of us will remember the cheerful and hearty "Look here!"—"Have you shown it to so and so?"—"Capital, capital."

The little wayside flower, and, from early happy associations, still more, the passing butterfly, for the moment seemed to engross his every thought. But the grandeur of the sea impressed him most; he never tired of wandering along the shore, now speaking of the great problems of earth's history, now of the little weed the wave left at his feet. His mind was like the lens that gathers the great sun into a speck and also magnifies the little grain we could not see before. He loved all nature, great and small.

Much we owe to Leonard Horner, himself a good geologist, for having inspired the young Charles Lyell. In after years, when already well known, Charles Lyell chose as his wife the eldest daughter of his teacher and friend. Many have felt the charm of her presence—many have felt the influence of the soul that shone out in her face; but few know how much science directly owes to her. As the companion of his life, sharing his labour, thinking his success her own, Sir Charles had an accomplished linguist who braved with him the dangers and difficulties of travel, no matter how rough; the ever-ready prompter when memory failed, the constant adviser in all cases of difficulty. Had she not been part of him she would herself have been better known to fame. The word of encouragement that he wished to give lost none of its warmth when conveyed by her; the welcome to fellow-workers of foreign lands had a grace added when offered through her. She was taken from him when the long shadows began to cross his path; but it was not then he needed her most. When in the vigour of unimpaired strength he struggled amongst the foremost in the fight for truth, then she stood by and handed him his spear or threw forward his shield. He had not her hand to smooth his pillow at the last, but the loving wife was spared the pain of seeing him die.

It doubtless occurred to many a one among the crowd who saw him laid to rest among the great in thought and

action, that he might have been eminent in many a line besides that he chose.

His was a well-balanced judicial mind, which weighed carefully all brought before it. A large type of intellect—too rare not to be missed. But it was well that circumstances did not combine to keep the young laird on his paternal lands among the hills of Forfarshire: it was well for science that he was induced to prefer the quieter study of nature to the subtle bandying of words or the excitement of forensic strife. Failing health had for some time removed him from debates. Still to the last his interest in all that was going on in the scientific world never failed, and nothing pleased him more than an account of the last discussion at the Geological Society, or of any new work done. As a man of science his place cannot be easily filled; while many have lost a kind, good friend.

#### THE "BESSEMER"

THIS novel steamer, upon the construction of which so much care and ingenuity have been expended, is expected to leave Hull for the Thames this week, and shortly will proceed upon her service between Dover and Calais. By experiments recently made at Hull, the power of the apparatus to put the ponderous saloon in motion alternately in opposite directions, has been fully established. It will no doubt be interesting to our readers if we place before them the following observations connected with the design of this vessel.

The chief objects of her designers, Mr. Bessemer and Mr. Reed, were—

1. To reduce the discomfort of the journey to a minimum.
2. To make her very swift, so that the time spent on the sea by her passengers should be as short as possible.
3. To ensure great steadiness among waves, both as to rolling and pitching.

Finally, to provide her with everything that can contribute to the comfort and convenience of the passengers.

All these points were carefully worked out and considered in connection with the limit imposed on her draught of water by the shallow harbour of Calais.

The *Bessemer* is a double-ended vessel, propelled by four large paddle wheels, two on each side. Each end for a length of about 48 ft. is kept low for the purpose of reducing the motions produced by the action of the wind and of the sea, while the middle portion (about 254 ft.) of her length is built sufficiently high to enable her to steam at a high speed against the worst seas she will meet. A rudder is fitted at each end with efficient means for locking, so that the *Bessemer* will be able to steam in either direction, and will not require to be turned round in harbour, and each rudder is worked by means of Messrs. Brown's patent hydraulic steering gear.

Her great peculiarity, however, is that she contains a large saloon 70 ft. long, designed by Mr. Bessemer, suspended in the middle of the ship in such a manner that it can be moved about a longitudinal axis parallel to the keel. The motion of this saloon, which would be set up if left free to move, when the ship rolled, will be governed by an hydraulic apparatus (the invention of Mr. Bessemer),

so that the floor of the saloon will, under all circumstances, be very nearly level.

The *Bessemer* is 350 ft. long, 40 ft. wide along the deck-beam, and 64 ft. wide across the paddle-boxes. She will be propelled at a speed of eighteen to twenty miles an hour by two pairs of engines of the collective indicated power of 4,600 horses. The centres of the two pairs of paddle wheels will be about 106 ft. apart.

The *Bessemer* saloon contains the main saloon, which is about 40 ft. long by 29 ft. wide, and 20 ft. high, six spacious retiring rooms, a refreshment room, lavatories, store rooms, &c. The decorations and fittings of the main saloon will be of the very best description, Mr. Bessemer having given this branch of the design his most careful attention. The retiring rooms, as well as the main saloon, are ventilated and heated by a very ingenious arrangement of fans, pipes, &c., which supply and exhaust air in an almost imperceptible manner.

Between the paddle-boxes on either side, and on the upper deck at the middle of the vessel, there are numerous private cabins for the accommodation of first-class passengers, and all of these cabins will be fitted up in a manner that will help to make the journey across the Channel as pleasant as possible. In addition to these, at one end of the vessel between the decks there is a fixed saloon about 52 ft. long, for second-class passengers. The luggage will be stowed in the hold at the opposite end of the ship to this fixed saloon, and two very ingeniously contrived hydraulic luggage cranes, fitted by Messrs. Brown, Bros., will be employed for lifting luggage off the pier and depositing it in the luggage hold, and *vice versa*, in a very expeditious manner.

The *Bessemer* saloon, however, will be by far the finest cabin that has ever been fitted in a ship. Its great size and height enables it to be ventilated imperceptibly, and will prevent passengers who use it from feeling the unpleasant sensations usually connected with going below. But one of the great advantages of this saloon is, that whatever motion the ship may take from the waves—and this, from the adaptation of her form to passivity among Channel waves, will be slight—the saloon will be practically free from it. It is in the middle of the ship as regards length and breadth, and the axis of rotation is at a height where there is least motion, so that as regards its position it is one in which the vertical and lateral motions produced in every part of the ship by the pitching and rolling will be small, and usually scarcely appreciable. The saloon also will have very little pitching motion, for the form of the vessel renders it impossible for the sea of the Straits of Dover to raise her low freeboard ends very considerably; and even, the small effects produced at the ends of the ship will be reduced to about one-seventh at the extremities of the saloon.

From the foregoing remarks it is evident that everything that promises to secure the passengers immunity from sea-sickness has been provided. In the saloon rolling and pitching motions will not be inconveniently felt, and any lateral or vertical movements that may be set up in the ship (and these must be obviously small when the main features of the design for preventing them are taken into account) will only be communicated to the saloon to the extent to which they exist at that part of the vessel where they are necessarily small.

It was intended by Mr. Bessemer to keep the floor of the suspended saloon level by means of an automatic apparatus which involved both the principle of the gyroscope and of Barker's mill. Certain practical difficulties, however, have led him to abandon that idea for the more simple and less costly plan which we will now attempt to describe. Immediately outside one of the ends of the saloon, and attached to the frames of the vessel, there is a pair of powerful pumping-engines. These engines keep up a constant supply of water to a large cylindrical accumulator. The hydraulic pressure so obtained is transmitted through pipes which pass through the hollow axle supporting the nearest end of the saloon to a very ingeniously contrived cylindrical slide balanced valve, which is placed on the athwartship floor girders near the middle of the saloon. The hydraulic pressure is next transmitted through the valve and through another system of pipes to two tipping cylinders, which are fitted one on each side of the vessel at the middle of the length of the saloon. These cylinders have their lower ends attached to two very strong athwartship girders, while the upper ends of the piston-rods are connected to the lower side of the upper deck. It will be readily perceived that the forces necessary to keep the floor of the saloon level are exerted on the ends of the athwartship girders just mentioned by means of the two sets of tipping gear. The direction of application of the hydraulic pressure on the pistons in the tipping cylinders is governed by means of a system of levers connected with the equilibrium valve. Near the end of the primary lever, and on its upper side, is fixed a spirit-level, and the man whose duty it is to work this lever regulates the distance through which he elevates or depresses the primary lever, so as to keep the air-bubble as near as possible coincident with the central mark on the level. It is assumed by this arrangement that when the spirit-level is "well" the floor of the saloon will be level, whatever rolling motion the vessel herself may have; and since this level is placed near the centre of gravity of the vessel where the angular motion is generally least, there can be no doubt that the saloon will at all times be pretty uniformly level.

#### THE ENCYCLOPÆDIA BRITANNICA

*The Encyclopædia Britannica*. Ninth Edition. Edited by Prof. Spencer Baynes. Vol. I. A to ANA. (Edinburgh: Adam and Charles Black.)

THE first volume of the ninth edition of the "Encyclopædia Britannica" has just been issued, handsomely printed and copiously illustrated.

The first edition of this venerable work was announced rather more than a century ago, as it began to be published in parts in the year 1771. The projector of the work was an Edinburgh printer of the time, Mr. Colin McFarquhar, and the editor and chief compiler was Mr. Smellie, also a printer. Another gentleman associated in the production of the work was Mr. Andrew Bell, a well-known Edinburgh engraver of the period.

The first edition ignored biographical, historical, and geographical matters; but these subjects were effectively introduced in the second edition, and have formed an important feature in subsequent issues. The second



edition was in every respect an improvement on its predecessor, and being extended to ten volumes, room was found for the extension and elaboration of many important topics.

The second edition was not, like the first edition, a mere compilation. The proprietors had early seen the necessity of employing the most talented men they could find to contribute the results of their special studies in literature and philosophy, and several eminent men of the period earned honourable remuneration by writing for the work; indeed, it is to the earlier editors of the "Encyclopædia Britannica" that scientific men owe it that their literary labours came so early to have a recognised money value. In the third edition, which was commenced early in 1788, the system of obtaining the best articles in physical science and literature from those who had made these subjects a special study was continued and extended, adding greatly to the value of the work. Mr. M'Farquhar, the proprietor, contributed very largely to its success by the unremitting attention which he bestowed on the editorial department. His labour in connection with the third edition, all the earlier portions of which he edited himself, had such an effect upon his health that he died in the fiftieth year of his age. Dr. Gleigh, of Stirling, afterwards Bishop of Brechin, who had been a voluminous contributor, was offered and accepted the editorship after the third edition had been begun. This learned gentleman aided in giving that high tone to the "Encyclopædia" which it afterwards maintained under the editorial supervision of Mr. Macvey Napier and Dr. Traill, and which, judging from the first volume, it is likely to maintain under the editorial superintendence of Prof. Spencer Baynes.

The services of Prof. John Robison, of the University of Edinburgh, were secured at an early stage, and that gentleman ultimately became a very voluminous contributor to the third edition. He renewed the article on *Optics*, and jointly with the editor produced the article on *Philosophy*. He also contributed the articles on *Physics*, *Resistance*, *Specific Gravity*, *Tides*, *Telescopes*, and numerous others. To a supplement of two volumes which was ultimately added to the third edition Robison was also a voluminous contributor; for this portion of the work he wrote many of the scientific articles, including *Astronomy*, *Dynamics*, *Electricity*, *Magnetism*, *Thunder*, *Trumpet*, and *Watch-work*. Prof. Robison undoubtedly did much to render the "Encyclopædia Britannica" the great work which it has become.

The issue of the third edition of the "Britannica" was completed in 1797 in eighteen volumes. Constable, at that time rising into fame as a great publisher, acquired the copyright of the supplement to that edition for the sum of 100*l.* Before long a fourth edition was called for, which was published in twenty volumes and completed in thirteen years from the time at which the third edition was finished. This edition was quite as successful as any of those which preceded it. It was edited by Dr. James Miller, and under his auspices the system of having the greater portion of the matter supplied by specialists was largely extended, and with the greatest possible advantage to the work.

After this time a new chapter in the history of the

"Encyclopædia" begins. Mr. Constable ultimately acquired the copyright, and at once set to work with his usual enthusiasm to improve the book, beginning with preparations for the issue of a "great" supplement, in emulation of the French work which had been the literary sensation of its time. This supplement was placed under the editorial charge of Mr. Macvey Napier, and the aid of Dugald Stewart was obtained as a contributor of one of the celebrated preliminary dissertations. His was on the History of Metaphysics and Ethical and Political Philosophy; the other dissertation was, if we mistake not, left unfinished by Playfair; it was upon Mathematics and Physical Science. This work was completed by Sir James Mackintosh and Prof. Leslie. Constable felt, when he had obtained the services of an eminent man like Stewart, and also of Davy, that he was entitled to ask all the great literary and scientific men of the day to aid him in his undertaking. He did so, and among the splendid list of contributors which he gathered around him were to be found the names of Arago and Biot.

A large sum of money in addition to the amount paid for the Dissertations was expended on the supplement; and there is no doubt that the public owe to the liberality and energy of Archibald Constable all the best features of the great work as it now exists. The supplement was ultimately and properly incorporated into the future editions of the work, the sixth and seventh editions of which were edited by Mr. Macvey Napier. It is unnecessary further to follow the literary fortunes of the book. Archbishop Whately and Prof. Forbes contributed each an additional dissertation. It would take up too much of our space to give a list of all the distinguished contributors to the seventh and eighth editions of the "Encyclopædia Britannica," many of whom were of world-wide celebrity at the time when they wrote, and many more of whom, then comparatively obscure, have since become famous.

Coming now to the ninth edition, it would not, we think, be any exaggeration to say that the first volume contains as much matter as the three "ill-furnished" quartos which embraced the whole contents of the work as originally projected. From being a mere compilation, the "Britannica" under previous editors had become a work of national importance, containing original treatises on science, art, and literature, by famous literary and scientific men. A glance at the first instalment of this issue warrants us in declaring that the work will lose nothing from having been entrusted to Prof. Baynes. Although he possesses what may be called a perfect mine of art, science, and philosophy in the preceding edition, it must not be forgotten that twenty years have elapsed since it began to be issued. During that period science and art have made vast strides, and history has not been standing still. In biography there are many new names to add to the list of the illustrious dead; and in geography, and trade and manufactures, many radical changes have taken place.

The two previous editions of the work began with the celebrated "Dissertations" to which allusion has already been made; but the present issue commences at once, if we except a brief and well-written preface, with the proper matter of the book in alphabetical sequence.

All mere [dictionary "words" have now been excluded from the "Britannica" by Prof. Baynes, who has thus gained a great deal of space for the illustration of more important matter. Those who have an opportunity of comparing the present with former editions will note the advantage of this plan. In the matter of biography great changes will doubtless be introduced, and mere locality will now cease to have an influence in this department; already, we observe that the account of Dr. Adam, an eminent Scotchman of the olden time, has been compressed into a few lines, and a similar plan will doubtless be adopted throughout the work—(though parenthetically let us ask why Aberdeen on the Forth, an insignificant watering-place, should have a place, while Aberdeen in the north of Aberdeenshire, notable in early Scottish history, and in "the grand old ballad of Sir Patrick Spence," be ignored?) On the other hand, subjects that have become important in our day are discussed at sufficient length, and a fair balance is kept up in the allocation of space. *Adulteration* may be cited as an example of what we mean. The article on that subject has been entrusted to Dr. Letheby, and it very profitably occupies seven times the space formerly allotted to it. The article *Æsthetics* has grown from a few lines into an excellent treatise, occupying no less than twelve pages of the new edition. Prof. Huxley has had over twenty pages allotted to his masterly article on *Amphibia*; he also contributes *Actinocœa*. *Agriculture* is discussed at a length suited to its importance; the article is divided into twenty-one chapters, and occupies 125 pages, and it is needless to say that it embraces an account of the latest discoveries and improvements in farming, including descriptions of what has been achieved by steam power. The article on *America* occupies forty-eight pages, and seventeen pages besides have been devoted to a disquisition on *American Literature*, by Prof. Nichol, of Glasgow, the son of the author of the "Architecture of the Heavens." The fact that the article *Alps* is by Mr. John Ball is a guarantee of its completeness and accuracy; the names and heights of all the chief peaks of the different ranges and groups are given. A most elaborate dissertation, by Prof. Turner, on *Anatomy*, occupies 109 pages of the volume, which concludes with that subject. There is an interesting biographical sketch of *Agassiz*. *Afghanistan* and *Africa* are, of course, brought up to the latest date. The treatise on *Algebra* has been revised—re-written, indeed—by Kelland; and in a recent number we alluded to Mr. Wallace's careful paper on *Acclimatisation*.

Prof. Baynes has taken the only safe method of securing articles that shall embody the fullest, and highest, and most accurate knowledge; viz., by obtaining the services of those who have proved themselves to be at the summit in their particular departments. To the present and to future generations, therefore, this ninth edition of the "Encyclopædia Britannica" must be regarded as indicating the highest tide-mark of the science, literature, and art of the time; and from this point of view the successive editions of the book are peculiarly interesting as showing the progress of knowledge during the periods that have elapsed between the times of their publication. We suspect that no edition will have required more modi-

fications to bring it abreast of the time than the present one; and, as we have said, Prof. Baynes has taken the best possible means to accomplish this purpose. In whatever other light it may be viewed, it must, when complete, be regarded as a magnificent collection of masterly treatises in every department of human learning.

This is scarcely the place, nor have we the space, to criticise the plan of the work. For mere purposes of ready reference, we suspect that less gigantic works will be found more useful. A really useful encyclopædia, one that would serve the first and chief purpose of such a work—a book of reference that may with the utmost facility be consulted at any time for information concerning any topic—should have its headings subdivided to the utmost possible limits. This will by many be considered the weak point of the "Britannica," and must be so, so long as the publishers insist on its being mainly a collection of elaborate treatises. This objection may to some extent be obviated by a thoroughly exhaustive index; but if an index is to be the chief apparatus for consulting an encyclopædia, then why not base the subdivision of the work on a logical and not on the alphabetical method?

But in view of the value of the "Britannica" as a treasury of the highest science and learning of our time, —and the publishers, we think, are justified in still retaining this as its chief characteristic—these objections may be considered as of minor importance; and of its value from this point of view there can be no manner of doubt. Prof. Baynes has already justified the choice made of him as editor, and shown himself in all respects competent to be the leader of such a splendid undertaking. We congratulate him on the success he has achieved, and wish him health and strength to carry on the work to its conclusion.

#### BROWN'S "MANUAL OF BOTANY"

*A Manual of Botany, Anatomical and Physiological, for the use of Students.* By Robert Brown, M.A., Ph.D., F.L.S., F.R.G.S. (Edinburgh: Blackwood, 1874.)

AT the present time there is a manifest want of an English text-book *au courant* with the modern state of those branches of botanical science which have to do with the minute structure, morphology, and physiology proper of plant-forms. The best that we have are often little more than introductions to the classificatory study of flowering plants. They give copious definitions and illustrations of the technical language which is needed in drawing up descriptions for the purposes of what are known as "systematic" works, but they have little to say—and that little is altogether out of date—about the important and various types which are lumped together as Cryptogams.

This state of things is obviously unsatisfactory. If the study of Biology proper is ever to make any progress amongst us, it must base its principles upon a comprehensive study of all living forms, and draw its illustrations from a wide survey of the vegetable as well as of the animal kingdom. If evolution is to be as fertile a principle in the investigation of vegetable as it has been in the case of animal development, it must take, in its own domain, as wide a scope. Lastly, if we are to turn

to any useful account the knowledge which is gradually accumulating of the part played by the simplest vegetable organisms in such phenomena as fermentation, putrefaction, and disease, a study of these and kindred organisms must play a much larger part than it has hitherto done in the botanical instruction given in the country.

Bearing in mind considerations of this kind, the publication of a new botanical text-book is a matter of considerable interest. It must, however, be at once confessed that the hopes which the admirable typography and attractive exterior of Dr. Brown's book at first sight excited have been most thoroughly dissipated by a somewhat cursory scrutiny of his pages.

The task which we feel it is absolutely necessary to undertake, of pointing out the signal badness of this book, is one of the most distasteful which anyone can assign to himself. The mere labour which is necessitated by the composition of some six hundred octavo pages of printed matter seems a sort of guarantee that the work will be in some degree genuine. And at first sight the plan which Dr. Brown has adopted is one which one cannot fail to approve. Instead of attempting, as most English manuals do, to treat the whole art and mystery of the subject in one volume, giving between the same boards a grammar of technical language, the elements of morphology, of taxonomy, of physiology proper, of distribution both in time and space, he has limited his subject in the present volume to all that concerns the higher plants alone. But the heaven cleaves to him still, and in each chapter, besides the description of the structure and functions of each several part, we have the old and tedious lists of technical terms, of which even systematic botanists trouble themselves now to use but a few.

It is, however, with respect to the detailed execution of the task that Dr. Brown has imposed upon himself that we feel obliged to speak in terms of unqualified condemnation. A book more utterly untrustworthy has probably never been issued for the use of confiding and un instructed students; and as there is a species of singular cruelty in placing in the hands of those who have to learn stores of knowledge which, to say the least, will prove bitterly deceitful when offered as the currency of a modern examination-room, it is to be hoped that some excuse may be accepted for a degree of indignation which may seem unusual even a review.

We will simply give a few extracts from Dr. Brown's pages in order that at least our botanical readers may form their own opinion as to how far what is said above admits of justification.

Here, for example, is a description of the red snow plant (*Hæmatococcus*) which will be a hopeless stumbling-block at the very outset (p. 14):—

"Each of these plants consists of a minute globule, distinct and separate, composed of a thin membrane perfectly closed in all its parts, colourless, but containing in the interior a red liquid. By-and-by granules appear in this red liquid, which grow and soon tear the envelope, and after a time give birth to other globular vesicles exactly resembling the mother cells."

*Hæmatococcus* is only a form of *Protococcus*—red, instead of green. Dr. Brown's account of its life-history is behind the age altogether.

On page 16 we are told of the cell-wall: "In its ori-

ginal form the membrane is thin, transparent, and colourless with a pearly lustre." A pearly lustre (not that it exists in this case) accompanies opacity, not transparency. Nor when we have disposed of the cell-wall in this self-contradictory fashion, can it be considered an altogether adequate treatment of protoplasm to mention it incidentally amongst the liquids contained in cells as "a granular viscid substance, composed of proteine and rich in nitrogen, and surrounding the nucleus" (p. 20). It is hardly necessary to observe that the nucleus is not independent of the protoplasm, but part of it.

The account of the nucleus itself is simply apocryphal:—

"In the leaves of *Orontium japonicum* it [the nucleus] is sufficient to cause elevated markings on the epidermis, each subjacent cell having a well-marked nucleus. It can be easily seen, especially if a little iodine is applied. In that case it takes a marked brown colour, and shows distinctly that it is composed of irregularly round transparent globules, though we do not yet know whether they are really globules or little cells—solid or empty" (p. 22).

Further on (p. 23) we learn that "alcohol decolorises chlorophyll by dissolving the resinous matter,"—the fact being that alcohol dissolves the chlorophyll itself from the protoplasmic granules which it colours. On p. 25 we have the astounding suggestion that chlorophyll is derived from the nucleus "in a manner analogous to that in which starch is."

On p. 50 we learn that "vessels by their union form vascular bundles often called fibres"—a statement erroneous from beginning to end. In the account of the structure of the stem of ferns (p. 99) the masses of sclerenchyma are confounded with the fibro-vascular bundles. The account of the stem of *Lycopodiaceæ* conveys no real information at all.

The sweet galangale (*Acorus Calamus*) is called (p. 103) *Calamus aromaticus*—*Calamus* being a genus of Palms. As further instances of slovenliness which could hardly be extended:—

"This point [*i.e.* the growing point of the root] is called the spongeole or spongelet, from a mistaken idea of its absorbent function. It was at one time commonly taught that this [*i.e.* the growing point] was the growing and absorbing point of the root" (p. 133).

A *Euphorbia* is given as an example of *Cactaceæ* (p. 146). The whole plant of *Lemna* is alluded to as representing a leaf (p. 147).

"In *Broussonetia papyrifera*, out of the pith of which paper is made, and out of the liber of which the Polynesi-ans weave their cloth, Ducharte notices the extreme diversity of the leaves" (p. 173). These irrelevant statements would be accurate were not the paper made from the bark and not the pith, and were not Tappa cloth a "felt" made by beating, and not a woven material at all.

Even the tedious lists of technical terms are not more accurate. The surface of the leaf, we are told (p. 205), may be "plan," to which *planum* is given as the equivalent; lower down *velvetinum* is given as the equivalent of villose.

It is sad to contemplate the fate of an unhappy examinee who should venture, trusting in Dr. Brown, to say it has been shown (p. 409) "that in many plants the pollen-tubes found at the micropyle at the time of impregnation

really originated there, and were not derived from the pollen."

Equally deplorable would be the result of affirming with Dr. Brown (p. 230) that "Turnip leaves contain 3 to 10 per cent. [of silica], oat 11 to 58 per cent. (especially in the stem), lettuce 20 per cent., oak-leaves 31 per cent., and beech-leaves 26 per cent."

It is unjust to the memory of Grew to assert that he ever disputed the discovery of the sexuality of flowering plants with Millington. Anyone who will refer to Grew's "Anatomy of Plants," p. 171, will see that he does perfect justice to Millington.

We had noted down a number of other passages equally open to criticism, but it is sincerely to be hoped in the interests of real botanical study that the specimens of this book which have been given will have some deterrent effect upon its possible readers. It is in vain that the author assures us that he has perused, for the purpose of his book, no less than 1,200 papers in almost every European language. A tithe of this literature properly selected and properly digested would have produced a manual of some value, instead of a mere chaotic dust-heap of all kinds of views belonging to all kinds of authors, as if scientific literature were in a way canonical, and the date of an author's views made no sort of difference, a common authenticity—like inspiration—embracing them all.

The blunders in the names of plants all through the book are quite as remarkable as the statements about their structure. *Chamaeparisus* (p. 101) is something more than a misprint for *Chamaecyparissus*, and it is astonishing to read about the "Brownonian" movements in a book whose author bears the honoured name of Robert Brown.

#### OUR BOOK SHELF

*Telegraph and Travel.* By Colonel Sir F. J. Goldsmid, C.B., K.C.S.I., &c. (London: Macmillan and Co., 1874.)

DURING the time of the late Bengal famine we were familiarised with seeing in the morning papers telegrams that had been despatched from Calcutta on the previous evening. Ten years ago telegraphic communication with India was but just completed *vid* Constantinople, the Persian Gulf, and Karāchi: but it was some years after that before rapid through communication was arranged. The delays occurred mostly between Persia and England, and much organisation of European lines was needed before it was possible to converse with Teheran as the Shah did on his arrival at Buckingham Palace.

Those who are interested in the subject of telegraphic communication with our Indian Empire (and who is not?) will find much information in Sir F. J. Goldsmid's "Telegraph and Travel." He gives an account of the origin and development of the schemes, the troublesome diplomatic delays, and the physical difficulties that had to be overcome, as well as the arrangements that had to be made in some districts to protect the overland lines from destruction by wandering tribes. An officer of experience among Turks of Europe and Asia expressed his opinion at the outset that every convention with the Arabs in the interest of telegraph companies would be uncertain of execution, and that all wire within reach would be torn down from the poles to make heel-ropes for their horses. Instances of wilful damage unhappily were found by experience to be not rare, so that in some districts

mounted guards were needed along wide tracts, adding, of course, considerably to the working cost of the lines.

The first part of the book the author feels is likely to be "found painfully practical and matter of fact, overburdened with official details and wanting in the zest which keeps the eye willingly open and the hand steady to the book," and he pleads in excuse "the necessarily monotonous character of the subject." The accomplishment of such a communication between the two countries, however, is so momentously important an event, that the history of its progress is of interest, however it is told. Sir F. J. Goldsmid's arrangement of his materials certainly does make it rather difficult to follow the thread of the history, but then it is enlivened with many interesting little sketches, descriptions of Persian diplomatists, their manner of conducting business, and so forth.

The first part of the book is illustrated with two maps which indicate the route of the different telegraphic lines between England and India, the dates being affixed to the different sections. Sir F. J. Goldsmid writes from his own experiences and from blue-books, and gives a mass of information which could not well be compiled by anyone not practically acquainted with the work.

#### LETTERS TO THE EDITOR

[The Editor does not hold himself responsible for opinions expressed by his correspondents. Neither can he undertake to return, or to correspond with the writers of, rejected manuscripts. No notice is taken of anonymous communications.]

Sir J. Herschel on the Endowment of Research

THE following extract from a letter from Sir John Herschel bears so directly on the distinction between the needs of theoretical and practical science insisted on in your recent leading article (vol. xi. p. 301), that I need offer no apology for communicating it. As the present value of the opinions which it expresses is intrinsic, it is unnecessary to particularise the circumstances under which the letter was written more than thirty years ago. But I may remark that it is supported by many passages in other letters in which the distinction in question, and that between research which *can* and research which *cannot* be readily effected by private means, is dwelt on (with all the scrupulous care of one than whom no responsible guardian of the public purse was ever more opposed to dependence on State aid as a principle), in a sense emphatically favourable to the demands of science for help in certain clearly indicated directions. I am sorry that I have not the papers at hand to quote from, but one instance in particular occurs to me, in which the extending and perfecting of various Physical Tables in a thoroughly satisfactory manner is declared to be altogether outside of the field of work of the individual investigator, and to be labour to be *paid for* by the community.

J. II.

Biarritz, Feb. 22

"... There is a remark which possibly it may be deemed presumptuous in me to make, relative to the general subject of scientific expenditure touched on [in your letter], but which I trust may be pardoned, as I have reason to believe my impressions on the subject are those of the whole body of British men of science, with hardly an exception. Large as the sum expended on objects officially classed as 'scientific' may appear it would not, I think, be considered as excessive if devoted to the prosecution of scientific objects in the highest and strictest sense of that word. I mean such as would be recommended for prosecution by men of science the most eminent, each in his several department, and responsible for their recommendations to the opinion of the public and of the scientific world. Under such objects I should certainly not include hydrographical, industrial, or military surveys, experiments merely technical, or many other objects, which, however indisputably necessary and

requiring for their due execution scientific and refined processes and the superintendence of scientific men of high qualifications, are yet, properly speaking, rather applications of scientific views and acquired skill to particular objects of national importance, than undertakings of research having in view as their primary object the advancement of science itself. It is true, that as practice makes perfect, science *does* gain by such applications, and that by going somewhat out of the way in their execution, and seizing opportunities, most valuable theoretical results and data are occasionally elicited at an additional cost incomparably less than would be incurred by instituting operations for the purpose *ab initio*. But when I consider the pregnant nature of scientific truth, and how upon occasion of every well-grounded accession to, or extension of, theoretical knowledge, a *new practice* has arisen founded thereon, and old methods have been abandoned as *inefficient* and *uneconomical* in comparison, I should feel prepared to advocate or defend a very large and liberal devotion indeed of the public means to setting on foot undertakings, and maintaining establishments, in which the investigation of physical laws and data should be the avowed and primary object, and practical application the secondary, incidental, and collateral one.

"This, however, has hitherto been the fortunate lot of Astronomy only. And the result has been, *not only* the establishment of a complete theory—*not only* the perfection of nautical tables and observation—but an universal impulse given to every other branch of exact inquiry—a higher standard erected everywhere, a precision in every determination rendered practicable, which would have never before been dreamed of as attainable without the requirements of Astronomy. Is it hoping too much that the day may not be far distant when Physical Science in all its exacter branches shall participate in these advantages, and when the establishment of 'Physical Observatories' in our own and distant lands shall give that impulse to many other sciences (as for example Magnetism, Meteorology, &c.) of which they stand so much in need?" . . . . "J. F. W. H."

#### Trade Winds

MAURY, in his "Physical Geography of the Sea," maintains that the surface trade wind of the northern hemisphere becomes the upper counter current of the south, and *vice versa*. That the trade winds, in fact, cross each other so—



FIG. 1.

instead of meeting and turning tack over themselves so—



FIG. 2.

Subsequent writers on physical geography have repeated this statement without apparently reflecting on its extreme improbability.

Maury's arguments for this strange theory are partly connected with the hygrometric state of certain of these currents, partly with terrestrial magnetism, and partly with the nature of the air-dust. It would take up too much of your space to discuss these points fully. The arguments founded on terrestrial magnetism are, however, purely hypothetical and very fanciful. Those on the hygrometric state of the currents are not very convincing. It is, however, to the latter of Maury's arguments I wish to draw your readers' attention. Maury seems to believe in this almost incredible direction of the air currents because Ehrenberg identified certain South American infusorial forms in

the red dust which often falls at sea near the West Coast of Africa and in South Europe. Did Ehrenberg simply identify certain South American forms in the dust, or did he identify the dust as South American on account of the presence of these forms? If the former, the argument goes for little; South American forms may be found in Africa also. If the latter, then a new difficulty arises. Every microscopist knows the curious diversity of infusorial forms in all climates at all similar. It would be the height of presumption even to question the conclusions of Ehrenberg in microscopy; and yet to be able to identify infusorial forms in such a way as to say that dust containing them comes from such and such a locality is certainly very wonderful.

Maury, from some of his remarks, does not seem to be fully alive to the utter inconsistency of his theory with what we know of the laws of fluid motion. That two broad flat rapid currents should encounter or flow into the same rising current and then cross through each other in alternate strips, or *curtles*, as Maury calls them, is scarcely within the bounds of physical possibility. On the other hand, Maury's opinions are certainly entitled to consideration, and this is one which he found with so much deliberation, and entertained so firmly, that I should gladly learn what competent physicists of the present day think of it.

Graeff Keinet College, Nov. 13

F. GUTHRIE

#### The Arctic Expedition

THE absence of sunlight during the Arctic winter is said to have an injurious effect on the health of both men and dogs; yet it does not appear that the best substitute for solar light has ever been employed for illuminating purposes during the dark season. It occurs to me that the occasional use of the electric-light would be likely to mitigate the evils due to the absence of solar radiation, and the constant use of oil lamps. If Gramme's electro-magnetic apparatus could be conveniently used on board ship, it would appear to offer the additional advantage of giving employment to the men at a time when it is difficult to find occupation for them.

Dublin, Feb. 23

R. J. MOSS

#### Herapath's Balance

CAN any of your readers inform me whether Herapath completed his balance, in which he suspended the beam from a magnet; also whether the idea was taken up by balance makers? He gives an account of this form of balance in a paper dated 1821.

E. W. P.

#### OUR ASTRONOMICAL COLUMN

THE BINARY STAR  $\mu^2$  BOOTIS.—Dr. W. Doberck, of Col. Cooper's Observatory, Markree Castle, Sligo, has communicated to the Royal Irish Academy, and also published in *Ast. Nach.* No. 2026, an orbit of this binary founded upon a very complete discussion of the measures from 1782 when the duplicity was detected by Sir W. Herschel, to 1873. The resulting period of revolution is 290 years, and the true peri-astron passage is found to have occurred about 1863.5. Dr. Doberck does not append an ephemeris of angles and distances according to his orbit, but we supply them for the next eighteen months for comparison with any measures that may be made in the interval:—

1875.25	Angle	144° 79	Distance	0" 632
75.75	"	142° 83	"	0" 634
76.25	"	140° 89	"	0" 637
76.75	"	138° 96	"	0" 640

FALB'S NEW VARIABLE IN ORION.—The star to which reference was made in NATURE last week, appears to be the preceding component of the double star  $\Sigma$  747, or that which was the smaller star during Struve's measures 1825-36. Herr Falb has given some particulars relating to this object in No. 2026 of the *Astronomische Nachrichten*, but we suspect he has inadvertently reversed the order in which the magnitudes of the Dorpat Catalogue should be assigned. Struve's mean is

1833.59	Angle	223° 06	Distance	35" 85
---------	-------	---------	----------	--------

whence the smaller star was in the south-preceding quadrant. In addition to the authorities for magnitude quoted by Herr Fälb, it may be mentioned that both components are found in the last Greenwich Catalogue (1864); the preceding star is there called 8 mag., and the following one 7. If we transform the differences of R.A. and N.P.D. in this catalogue into angle and distance, there results for about

1866'95. Angle 224°5'. Distance 36''4

agreeing as closely with Struve's measures as could be expected. The principal or following component of  $\Sigma$  747 is Bradley 801, and its position for the beginning of the present year is in R.A. 5h. 28m. 54s'4, and N.P.D. 96° 5' 39"; it is 8' distant from  $\epsilon$  Orionis, on an angle of 225°.

THE VARIABLE STAR R HYDRÆ.—Observations of this star in southern latitudes are much needed for affording a better insight into the law of variation than we yet possess. That the period has greatly diminished since the time of Maraldi is beyond doubt; Schönfeld makes it about 500 days for the year 1708, 487 days for 1785, and 437 days for 1870. It was pointed out by Argelander that good comparison stars are too low for favourable observation in central European latitudes. According to the formula involving  $E^2$  and  $E^3$ , given in Schönfeld's last catalogue, a maximum would occur on the 25th of February, and the following one falls 1876, May 10. The minimum, which by Schmidt's observations occurs 200 days before the maximum, will not be observable in the present year. At greatest brightness the star is found to vary from 4°0 to 5'5. Its position for 1875 is in R.A. 13h. 22m. 53s., and N.P.D. 112° 38'0.

WINNECKE'S COMET.—This body is now beyond reach and it is probable that the observations which have been secured will be few in number. It is nevertheless evident that the elements are very well determined; a very small acceleration which is also indicated in previous revolutions being sufficient to produce an exact agreement between Prof. Oppolzer's calculations and the result of the first Marseilles observation. Reference was lately made to the Vienna astronomer's suspicion of identity of this comet with one of the imperfectly observed comets of 1808—that which was discovered by Pons on Feb. 6th and seen again on the 9th. On examining the matter more closely there appears to be strong reasons to doubt this inference, upon which we may enter in a future notice.

THE ZODIACAL LIGHT.—Another conspicuous exhibition of this phenomenon was observable in the neighbourhood of London on the evening of February 25. The sky was very vaporous, and the smaller stars usually visible without a telescope were not discerned, but soon after 8 P.M. the light was quite a marked object in the heavens; it did not present the lemon tinge which is commonly the case when the sky is clear, but rather resembled the light of the Milky Way, except that it was of much greater intensity. It could not be traced that evening beyond the constellation Musca.

NEW MINOR PLANET.—Le Verrier's *Bulletin* of Feb. 27 announces the discovery of a new member of the minor planet group by Herr Palisa at the Observatory of Pola on the 23rd. Its position at 8h. 42m. local time was in R.A. 9h. 57m. 56s., N.P.D. 76° 14'. The planet is of the twelfth magnitude.

#### SCIENCE AT THE NEW PARIS OPERA

THE New Paris Opera has excited a great deal of attention among all classes, both on the Continent and in England. Every effort has been made to make the building perfect in all respects, and to carry out its construction in harmony with the latest scientific princi-

ples. Some recent numbers of *La Nature* contain a series of articles by M. G. Tissandier on the new building, to show in what manner the principles of science have been made to conduce to the welfare and comfort of art. A few of the points in these articles we shall bring before our readers, as also some of the illustrations, which have been obligingly lent us by the proprietors of our sister journal. M. Tissandier deals first with the subject of Warming and Ventilation.

It is not astonishing that the ventilation of theatres has been effected in a very incomplete fashion, when we consider the difficulties which stand in the way of a complete solution. "A theatre is composed not of a single compartment, like every other place of assembly, but of three vast, contiguous compartments: the hall (or auditorium), the corridors, and the stage, all which, at certain times are separated, at others connected by vast openings. To this first difficulty must be added the action of the lustre, which causes a strong current of sonorous waves towards the ceiling, greatly to the detriment of the acoustics and to the equality of temperature in the various parts of the auditorium. The position of the spectators in tiers rising one above the other along the walls, and not horizontally, adds a new obstacle to the efficacious renewal of the air. Moreover the conditions of the problem are constantly changing. Thus, before the entrance of the public the heating may have taken place downwards and by the ordinary means; but, once the public have been admitted and the curtain raised, a considerable mass of air, that of the stage, is put into communication with the body of the theatre. Between the acts this communication ceases; but, on the other hand, there are from 1,000 to 1,500 persons, just so many living stoves, and some hundreds of gas-jets, which heat and gradually vitiate the atmosphere. Hence a change must be introduced in the ventilation; still another change when the curtain is raised; and all this to be modified according to the season."\*

At the commencement of the present century the Marquis de Chavannes devised a system, which was tried at Covent Garden Theatre, and which contained the principle of all the methods since invented.

The heating of the stage was effected by steam cylinders, shown at M, in Fig. 1. Ventilation took place at N above. The auditorium was heated by the large stove B, which by cylindrical pipes sends warm air under the flooring of the boxes and into the staircases. At R the vitiated air of the boxes met, drawn off by the openings A A A. The vitiated air of the body of the theatre drawn upwards by the lustre, reached O, after having traversed the openings P P.

In 1828 a commission, composed of Bérard, Cadet de Gassicourt, Marc, and d'Arcey, was entrusted in France with an investigation into the principles of the ventilation of theatres. Fig. 2 represents the arrangement devised by d'Arcey, who took advantage of the lustre to convey outside the air vitiated by the combustion and by the breath of the audience. The warm air is introduced into the corridors by the openings C C C; it enters the auditorium by passing under the flooring of the boxes, in the direction of the arrows. The exit of the air takes place at U; it may be regulated above the lustre by means of the movable traps at T. It is also accomplished at V, by passages which are united in the central chimney.

These systems had serious drawbacks. An attempt at improvement was made in 1861, during the construction of the new theatres in the Place du Château. For the purpose of investigating the question a commission was nominated, presided over by M. Dumas, Perpetual Secretary of the Academy of Sciences, and having for reporter General Morin, Director of the Conservatoire des Arts et Métiers. After many experiments and many contra-

\* "Traité pratique du chauffage et de la ventilation," by V. Ch. Joly.

dictory advices, they fixed on the arrangements advocated since 1860 by M. Trélat.\* The system was found, however, to be ineffective.

The question was in this state when M. C. Garnier was called upon to construct the new theatre, which at present justly attracts the attention of all.

The arrangements adopted in the New Opera, without being exactly new, are remarkably improved; if the principles upon which they are founded are almost the same as those referred to above, an effort has been made to apply them under the conditions best calculated to ensure a favourable result.

Of fourteen large stoves fixed in the underground part of the building, some, by means of hot water, heat the administrative department, the stage, and the rooms of the artistes; others, by hot air, the auditorium, the green rooms, and the staircases. The daily consumption of these fires has been estimated at 10,000 kilogrammes of coal—nearly ten tons.

The water and air heated by the stoves are distributed by brass pipes, the heating surface of which is about 2,250 square metres, their length nearly five kilometres. Those filled with hot water are contained in grooves in the masonry; the air coming from without circulates around their surface, is heated, and escapes by 650 orifices.

For the auditorium and its approaches recourse has been had to water-stoves, which give a very considerable renewal of air. "The apparatus to the number of ten," says M. Nutter, "are supplied by twelve furnaces, whose power represents a steam-engine of 120-horsepower. It was necessary to employ apparatus of this power, for as they are only used in the days of performance, they are not kept constantly lighted, and they must rapidly raise the temperature of spaces whose capacity is not less than 90,000 metres. They must, moreover, provide in the auditorium for a renewal of air which may reach 80,000 cubic metres per hour; thus we must reckon

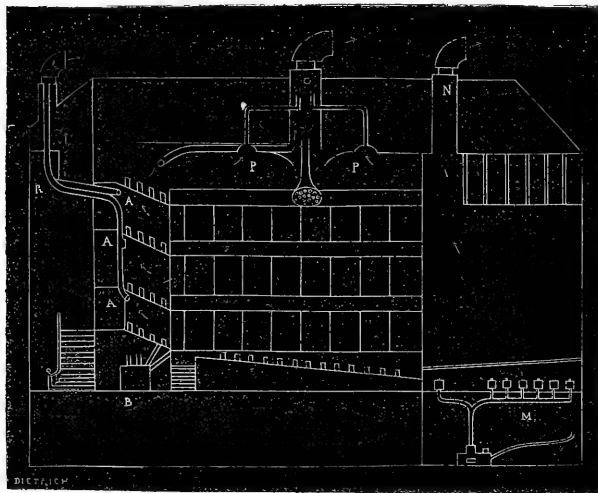

FIG. 1.—Ventilation of a Theatre (Chavannes' system).

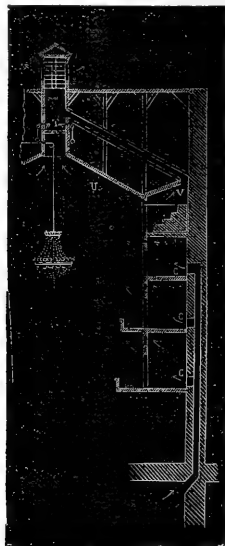

FIG. 2.—The System of d'Arceet.

the warm air heaters at from 600 to 700 square metres, and the hot water ones at from 1,200 to 1,300 square metres."

Ventilation is effected by means of supplies of air, the openings for which measure from twenty-four to thirty square metres. The cupola of the auditorium is pierced by bulls'-eyes, and is also supplied with openings arranged above the lateral galleries. Fig. 3 shows the cupola seen from above; it shows the vast conduits which carry off the internal air by means of the draught of the lustre. The supplies of air are regulated by thirty-four registers, large valves of  $1\frac{1}{2}$  metres long and  $\frac{3}{4}$  metre high, placed around the cupola. A large sheet-iron chimney, eight metres in diameter, surmounts the ventilating erection, and leads to the lantern which surmounts the cupola.

Thanks to these excellent arrangements, thanks also to the large proportions of the corridors, there is reason

\* "La Theatre et l'Architecte."

to hope that in the new Opera aëration will be accomplished under satisfactory conditions, and that in this new building the constructors will have approached as nearly as possible to that solution of a problem whose difficulties have been pointed out above.

The lighting of the New Opera has been accomplished with considerable ingenuity. The whole of the gas-pipes represent a length of twenty-five kilometres, on which are adjusted 714 cocks. The dangers attendant on the ordinary method of lighting a stage by naked footlights are well known. The footlights of the New Opera are formed of gas jets with reversed flames, each flame being completely enclosed, so that only the light escapes, the heat being conveyed outside. Each jet is so constructed that if the glass which encloses it is broken, the flame becomes extinguished by an automatic arrangement. In Fig. 4, E is the conducting tube of the gas. It is lighted by raising it at D, above its vertical glass. When it is placed upon



its glass the flame is drawn downwards by a powerful current of air which circulates in a lower pipe to which

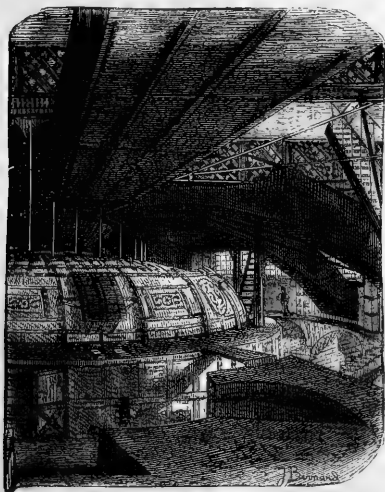

FIG. 3.—Ventilating Apparatus of the New Opera. (From M. Nutter's work.)

the tube B is fitted. Owing to the draught the burner does not become heated, and the hand may be placed upon it without being burnt; the robe of a dancer may without danger brush it, since the flame is produced in an enclosed space. If the glass A is accidentally broken, the burner E, mounted on a pivot, is lowered at C, and by this movement sets in motion a small valve, which shuts off the gas, and the light is thus put out. The jets of the footlights are arranged in series of twelve, and number in all 120. These 120 lights may be raised to the height of the stage, or lowered underneath the prompter's hole, below the flooring of the front stage, by a mechanism which draws them all together, and which two men can easily move.

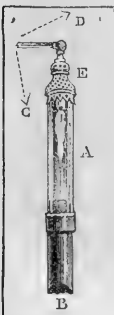

FIG. 4.—Gas-jet, with reversed flame, used in the footlights of the New Opera

By a very ingenious arrangement all the lights in the theatre can be lowered suddenly so as to produce a night-effect, without the least danger of any of them being extinguished.

One of the most important applications of science in the New Opera is the use made of electricity, which we shall describe in another article.

(To be continued.)

sphere; of the height to which the various vapours extend from the photosphere, and of the order in which they thin out. It is anticipated that the chromosphere, at all events, may be very rich in ultra-violet rays. The solar spectrum has already been photographically compared with metallic vapours from G some distance outwards. The operations, therefore, will be mainly photographic, glass being employed as little as possible to produce the necessary dispersion, and replaced by quartz. The attack is twofold, spectroscopes being used in conjunction with telescopes for obtaining line spectra, and prismatic cameras being employed for the purpose of obtaining images of the chromosphere and coronal atmosphere built up by the rays emitted by its various constituents. The prismatic camera will probably give the best results with regard to the height and order of the various layers, while the general nature of the spectrum beyond H, *i.e.* whether it is continuous, channel-spaced, or lined, will be best determined by the ordinary spectroscopes.

*Adjustment of Spectroscopes.*

Take out camera, and determine focal point for blue rays by receiving image of sun on ground glass, and by using solution of sulphate of copper in ammonia in front of object-glass. (The strength of solution to be determined beforehand such that no light less refrangible than G should pass at all, and that the centre of gravity of spectrum is H, or outside it.)

To determine focus of collimator, reinsert camera and move sliding portion of collimator attached to slit-plate till the lines of the spectrum at or outside H are clearly defined.

All prisms to be set for minimum deviation of H.

To find proper distance of slit-plate from telescope, throw image of sun on, so as to cover half the slit, and adjust the spectroscope to such a distance that the boundary of the spectrum of the photosphere at H is perfectly hard.

Photographs should be employed for ascertaining the focus; the slits to be clean, and adjusted so that at least three lines be seen between the two H's. No photograph need be examined which will not bear a magnifying power of ten times. It must be remembered that a difference of 1-100th of an inch is of importance in such adjustments. The best definition with the dispersion employed will be attained when the line in the middle between the H lines is seen double.

The hardness of the sun's limb to be determined photographically in the same manner.

If power to incline the plate is obtained, the part of the plate to receive the more refrangible rays will, of course, be nearer to objective of camera, as in the case of all non-achromatic lenses. The angle to be determined by experiment. The spectrum should fall on the plate so that G falls close to one edge, the central and other portions of the plate being reserved for the more refrangible end of the spectrum.

Care must be taken that the axes of the collimator and of the telescope be coincident.

*Adjustment of Prismatic Camera.*

This instrument is to be adjusted like an ordinary spectroscope by means of collimator placed in front of its prism. By application of external collimator, the prism is to be set to minimum deviation of H, the hydrogen line near G falling near one edge of the plate.

Before this instrument is put on the telescope, the prism thus adjusted should be taken off and perfect parallelism of the tubes obtained by observing the images of the sun or star.

The subsequent inclination of the two axes will be determined by taking photographs of spectrum with or without a collimator, so that ring corona near G will be the least refrangible portion of spectrum on plate, while the sun falls on the steel plate of the telescope to which

ENGLISH GOVERNMENT ECLIPSE EXPEDITION, 1875

INSTRUCTIONS TO OBSERVERS.\*

1.—Spectroscopic Observations—Objects to be attained.

The objects to be attained are mainly the determination, so far as may be possible, of the chemical constitution of the chromosphere and of the coronal atmosphere.

\* Drawn up by the Eclipse Committee of the Royal Society.

the prismatic camera is attached. Care should be taken that the least refrangible part of the ring corona should be recorded. The axis of the camera should cut the axis of the declination axis.

#### *Observations to be made with Telespectroscopes.*

Before and after totality the cusps should be continually thrown on the slit and the spectrum photographed; long exposures should be at first employed. At least one spectrum of the sun should be obtained before totality, with the ordinary position of the plate, in order to indicate the parts of the plate on which the various parts of the spectrum falls with the angle of deviation and the orientation adopted.

In all instruments just previous to totality, the vanishing portion of sun is to be used to obtain a scale on the plate on which the attempt will be made to obtain the spectrum of Young's stratum, and the other phenomena at the beginning of totality.

For this purpose one of the end windows will be opened, and all the others closed in the first instance, the open part of the slit being arranged radially over that portion of the sun's light which will be the last to disappear. Immediately before totality all the windows are to be opened without deranging the instrument.

The time for which the plates are to be exposed after the commencement of totality will be subsequently referred to.

For observation at end of totality all windows except one at the end of slit to be opened. The part of the sun which will first reappear should lie on the slit just outside the closed shutter (the motion of the moon being taken into account), so that the phenomena at moment of reappearance may be photographed. Immediately after reappearance the previously opened shutters should be closed, and the previously closed shutter should be opened to obtain the solar spectrum as a scale. Care should be taken not to confound the brighter parts of the chromosphere, at reappearance, with the sun itself.

#### *Observations with the Prismatic Camera.*

A trial photograph can be made when 1-100th part of sun's diameter is still visible. The results of development of the spectrum of the two cusps should determine the time of exposure before totality; as many photographs should be obtained as possible before totality, being rapidly multiplied just before disappearance. The number of plates to be taken during totality to be subsequently referred to. The number of plates to be obtained after totality will depend on results of development before totality.

#### *2. Observations on the Polarisation of the Corona.*

The primary object of these observations was to furnish evidence on the question whether the corona was a true solar phenomenon, or in some way due to a glare in the terrestrial atmosphere. In the former case the position of the plane of polarisation (if the light were polarised at all) would have reference to the sun's centre, and would be parallel or perpendicular to a line joining the centre to the point observed. In other words, the polarisation would be radial. In the latter case it would have reference to the general direction of the observers' view; *i.e.* it would be uniform over the whole area of the corona.

Former observations appear to show that the total light from the corona is partly polarised; and that the polarisation is in part radial, and in part unidirectional. In addition to this, spectroscopic observations have connected the corona with the sun. But, although the main question may consequently be considered as already settled, the polariscopic observations have been found so delicate as to justify their repetition. The details of polarisation, if sufficiently well defined, may tell us something of the condition of the matter emitting coronal light; and if to former eye observations photographic pictures be added, our information may be extended to regions further from

the sun's surface than any of which we have at present cognisance.

If a Nicol's prism be placed in the tube of a telescope of long focus (*i.e.* in which the convergence of the rays from the object-glass is not so great as perceptibly to affect the analysing power of the Nicol), then, on turning the Nicol so as to cut off the part of the light polarised in one plane, we shall see only that which is radially polarised together with the unpolarised light.

The part of the light polarised radially would, without an analyser, appear as a complete ring of light, except so far as it is interrupted by rifts or other irregularities; but with the Nicol the ring will appear divided into two halves, brightest at the points where the radial polarisation coincides with that due to the Nicol, and shading down to the intensity of the unpolarised light alone at points situated  $90^\circ$  from the former.

In other positions of the Nicol the atmospheric polarisation will be less and less suppressed; and at a position  $90^\circ$  from its first, it will retain its full relative intensity.

A quartz or a biquartz might, of course, be used, but with feeble light the eye is better able to distinguish between differences of intensity than between differences of colour.

To use the instrument sent out. On the day before the eclipse, take out the eye end containing the Nicol and camera and turn the Nicol, till the bottom of the camera being horizontal, the light reflected at the polarising angle, from a polished mahogany surface is cut off.

The first photograph should be taken with the instrument so adjusted, and the camera and Nicol must be inserted in the telescope so that the top and bottom of the plate are horizontal when the telescope is directed to the sun.

The first photograph to be exposed for 25 seconds.

Between each photograph the camera and Nicol to be rotated through  $30^\circ$  in the direction of the hands of a watch.

It is desirable that some of the exposures should be long, as by this means the extent of the corona can be best determined.

If the development shows that it may be attempted with advantage, one or two photographs may be taken with very short exposures.

The adjustment of this instrument to the blue rays must be most carefully determined beforehand, as the object glass is not corrected for them.

#### GENERAL REMARKS.

##### *Plates during Totality.*

The number will depend upon experiments to be made on the rapidity of drying and decrease of sensibility. If it is found that plates may be exposed during the whole of totality, some plates at least should be exposed for the whole of that time. In prismatic camera, one may be exposed for one minute to begin with. Whether the next plate should be exposed during two or three minutes to depend on results of development.

##### *Width of Slit.*

Arrangements should be made for readily securing the opening of slit which gives the best testing effect referred to before, and a wide opening which allows at least one line being seen between the H's, can be readily distinguished. This latter opening should be used in all observations during totality. For scale determinations the first position of slit should be employed. In some instruments a much wider slit may be used than in others. Experiments should be made on this point.

##### *Precautions to be attended to in preliminary experiments.*

1. All apertures to be reduced. The slit should not be exposed longer than necessary to the heating power of the sun.

2. Object-glasses and mirrors not to be unscrewed from their cases till telescopes are perfectly mounted.

*Precautions to be attended to half an hour before Totality.*

1. If an aperture has been reduced for preliminary experiments, take care that full apertures are restored.

2. In case any telescopes are used for eye observations, reminder should be given to take off dark glasses before totality.

3. Wind up all clocks.

4. Let all strangers withdraw.

5. Light lamps.

#### *Arrangement of Photographic Plates.*

As the plates are smaller than was intended, the spectrum must be thrown along the length of the plate, and, if possible, in the prismatic cameras, from corner to corner.

A shelf should be prepared over the developing table with places marked 1, 2, 3, &c. The backs used in any one instrument should be labelled in large letters on both sides, and a similar label should distinguish each shelf. The plates will then arrange themselves into series, and can be numbered afterwards. Care must be taken to have lamps in the dark room.

#### *The Time Teller.*

One person should be detailed at each station to tell the time.

The chief observer at each station will give the signal for commencement for totality, which being done, the time assistant will call out the number of seconds of calculated duration at the locality. If, for instance, the totality is four minutes, he will say "You have 240 seconds," and go on calling out every ten seconds the number of seconds still left for work. A clever man can do this in a very encouraging way. The time counter should take care not to distract himself by losing sight of the face of the watch or chronometer, and it is to be impressed upon him that much of the success of the observations will depend on his undivided attention, as his statement of time will be an order to the observers to do certain work.

#### *Rehearsals.*

There must be at least two complete rehearsals of the whole attack on two previous days at the time of the eclipse, and the final written instructions to each observer given by the chief of the party will mainly depend on the experience of these rehearsals, which must be of a very serious character. It must be recollected that the speed and skill in collodionising and developing can only be thus determined.

The going of the clocks and counterpoising of telescopes in the particular position in which they will be employed near the time of totality must be examined with the greatest care, and the best regulation of the clock for this position should be adhered to. In these rehearsals all apertures must be reduced.

The clock weights must also be examined, and increased if necessary to produce a uniform motion of the telescope.

#### *Silence.*

Silence must only be broken by the timekeeper. The rehearsals should be utilised for asking any questions touching any part of the duties of each observer during the observations, and each observer should have his programme of work nailed up where it can be easily seen.

In order to prevent noise and interruptions, none but the observers and trained assistants should be allowed to be within fifty yards of the observatories, for an hour before and an hour after totality.

#### *Programme of Work.*

The Programme of Work may conveniently be stated in the time called out by the time observers. In which

case "200 seconds more," and so on, will become an instruction to one of the observers to do a particular piece of work.

#### *Notes on the Phenomena Observed.*

Anything an observer has to record should be done immediately after totality, or the last observation after totality.

Trust nothing to memory; a note made the next day will be comparatively valueless.

#### *Multiplication of Results.*

As soon as convenient after the eclipse, before leaving the station, at least four copies of every photograph must be made, and enlargements, if possible, in duplicate on glass. Paper copies of these duplicates should be transmitted by two different mails to the Royal Society. The various copies to be sent home if possible by different mails and different routes. One copy to be left in India and given in charge of the chief of the Indian expedition.

#### *Photographs of the Corona.*

It will be very desirable for the observers appointed by the Indian Government to depict photographically the corona as a whole, to take some photographs on plates so placed in the long focus camera (rectilinear lens) that the back of the plate is towards the object-glass and the collodion towards the observer, in order to avoid reflection from the second surface of the glass. Special plate holders will have to be made, and the glass selected as perfect as possible and of nearly the same thickness. Of course the back must be carefully cleaned before the plate is exposed.

#### *Observations to be reduced by the Royal Society.*

It is understood that the observations made by the members of the English Expedition are the property of the Royal Society, by which body they will be reduced. It is hoped that the Indian Government will allow duplicates of the observations taken by the Indian parties to be forwarded to the Royal Society to aid in these reductions, and to enable a general account of the whole attempt to be prepared. The English observers detailed to India will co-operate with the Chief of the Indian station to which they may go, and will assist in carrying out the arrangements in accordance with the foregoing instructions.

All experiments made for the furtherance of the objects of the expedition will be carefully recorded and will be considered the property of the Royal Society.

#### *SCHOLARSHIPS AND EXAMINATIONS FOR NATURAL SCIENCE AT CAMBRIDGE, 1875*

THE following is a list of the scholarships and exhibitions for proficiency in Natural Science to be offered at the several Colleges and for non-collegiate students in Cambridge during the present year:—

*Trinity College.*—One or more scholarships of 100*l.*, and one exhibition of 50*l.* The examination for these will commence on March 30. Further information may be obtained from the Rev. E. Blore, Tutor of Trinity College.

*St. John's College.*—One of the value of 50*l.* per annum. The examination (in Chemistry, Physics and Physiology, with Geology, Comparative Anatomy, and Botany) will commence on April 3, and will be open to all persons who have not completed a term of residence at the University, as well as to all who have entered and have not completed one term of residence. There is a separate examination in Natural Science at the time of the annual College examination at the end of the academical year, in

May; and exhibitions and foundation scholarships will be awarded to students who show an amount of knowledge equivalent to that which in Classics or Mathematics usually gains an exhibition or scholarship in the College. In short, Natural Science is on the same footing with Classics and Mathematics, both as regards teaching and rewards.

*Christ's College.*—One or more in value from 30*l.* to 70*l.*, according to the number and merits of the candidates, tenable for three-and-a-half years, and for three years longer by those who reside during that period at the College. The examination will be on April 6. There are other exhibitions which are distributed annually among the most deserving students of the College. Further information may be obtained of John Peile, Esq., Tutor of the College.

*Gowville and Cains College.*—One of the value of 60*l.* per annum. The examination will be on March 18, in Chemistry and Physics, Zoology with Comparative Anatomy and Physiology, and Botany with Vegetable Anatomy and Physiology. Further information may be obtained from the Tutors. Scholarships of the value of 20*l.* each or more are offered annually for Anatomy and Physiology to members of the College. Gentlemen elected to the Tancred Medical Studentships are required to enter at this College; these studentships are five in number, and the annual value of each is 100*l.* Information respecting these may be obtained from B. J. L. Frere, Esq., 28, Lincoln's Inn Fields, London.

*Clare College.*—One of the value of 60*l.* per annum, tenable for two years at least. The examination (in Chemistry, Chemical Physics, Zoology with Comparative Anatomy and Physiology, Botany with Vegetable Anatomy and Physiology, and Geology) will be on March 16, and will be open to students intending to begin residence in October.

*Downing College.*—One or more of the value of 60*l.* per annum. The examination (in Chemistry, Comparative Anatomy, and Physiology) will be on April 6, and will be open to all students not members of the University, as well as to all undergraduates in their first term.

*Sidney College.*—One of the value of 60*l.* and one of the value of 40*l.* per annum. The examination (in Heat, Electricity, Chemistry, Geology, Zoology and Physiology, and Botany) will be on April 6, and will be open to all students who intend to commence residence in October.

*Emmanuel College.*—One of the value of 70*l.* The examination, on March 24, will be open to students who have not commenced residence.

*St. Peter's College.*—One scholarship of the value of from 40*l.* to 80*l.* according to the attainments of the candidate. The examination on April 6 will be in Botany, Chemistry and Chemical Physics, Geology, and Comparative Anatomy and Physiology, but no candidate will be allowed to be examined in more than two of these subjects. Application must be made before March 20 to the Tutor.

*Non-Collegiate Students.*—An exhibition each year is given by the Clothworkers' Company, value 50*l.* per annum, tenable for three years. Examination about Christmas. Information to be obtained from the Rev. R. B. Somerset, Cambridge.

Although several subjects for examination are in each instance given, this is rather to afford the option of one or more to the candidates than to induce them to present a superficial knowledge of several.

Candidates, especially those who are not members of the University, will, in most instances, be required to show a fair knowledge of Classics and Mathematics, such, for example, as would enable them to pass the Previous Examination.

There is no restriction on the ground of religious denominations in the case of these or any of the scholarships or exhibitions in the Colleges or in the University.

Further information may be obtained from the Tutors of the respective Colleges.

Some of the Colleges do not restrict themselves to the number of scholarships here mentioned, but will give additional scholarships if candidates of superior merit present themselves; and other Colleges than those here mentioned, though they do not offer scholarships, are in the habit of rewarding deserving students of Natural Science.

It may be added that Trinity College will give a fellowship for Natural Science, once at least in three years; and that most of the Colleges are understood to be willing to award fellowships for merit in Natural Science equivalent to that for which they are in the habit of giving them for Classics and Mathematics.

The above list shows that Colleges at Cambridge, like those at Oxford, are by no means backward in offering inducements to the study of Natural Science. The scholarships and exhibitions are open to all persons, whether members of the University or not, provided they are willing to enter and become members of the respective Colleges, with the exception of the 100*l.* scholarships at Trinity College, the candidates for which must have passed the Previous Examination at the University.

## NOTES

NEWS has been received from the English Eclipse Expedition dated from Suez: all were well. The *Surat* had been delayed a day by the loss of her screw in the canal, doubtless in that narrow rocky part of the canal some miles above Suez, where so many ships have lost their screws, and the Expedition has proceeded to Galle in the *Baroda*. Arrangements have been made with the Indian Government to have a ship waiting at Galle on the 16th inst. to convey the Camorta party from that place. We publish this week the Instructions to the observers, issued by the Royal Society Committee.

THE Astronomer Royal has communicated the following telegram to the press relating to the Transit of Venus observations at Kerguelen's Land:—"Corbet, Coke, Goodridge observed ingress. Perry good egress. All something. Cloudy. Generally, English photography poor. Americans, Germans lost interior contact. Americans have some photographs."

We have received a letter, dated Jan. 8, from Mr. C. Meldrum, Mauritius, containing the following additional information regarding the transit observations at the Mauritius:—"The new Observatory is seven miles from Port Louis, and by the time the instrument was received and put in place, we were within a few days of the Transit of Venus. You will have heard (I sent you some newspapers by last mail) that owing to the weather, Lord Lindsay and his party, as well as the German Expedition, could only observe the latter half of the Transit, and that they lost the first external and internal contact. Here at this Observatory I had worse weather, the sky being entirely overcast during the greater part of the time. But it so chanced that the weather clearing up for a short time, and the sun appearing, I got the first internal contact just as the sun was emerging from behind a bank of clouds. We had then a long spell of cloudy rainy weather, with occasional glimpses of the sun. Towards the time of second internal contact the weather again cleared up, and I observed that contact under more favourable circumstances than the first internal. On both occasions I saw a dark band or ligament connecting the limbs of the sun and planet, and noted the times of appearance and disappearance. The first internal contact took place some minutes after the computed time, and the second internal contact a little earlier. Our photo-heliograph arrived after the transit. Both Lord

Lindsay and the Germans are satisfied with what they have got. The morning before the transit was beautifully clear and in every respect favourable, but the morning after was just the reverse, the sky being entirely overcast. Both expeditions should have been at their post earlier. The English expedition to Rodriguez was successful in regard to weather, which is a lucky incident, for the chances in favour of Mauritius were greater. The fact is that there was an atmospheric disturbance, probably a gale, passing to the N. and N.W. of Mauritius and Bourbon on the 9th, which had passed Rodriguez some days sooner. Lord Lindsay has a slight attack of fever. He leaves soon for India *en route* to England. Davies is going to observe the solar eclipse of the 6th April in Buimah. Dr. Copeland will probably go round the Cape in the *Venus*. Mr. Gill left for Aden to-day with his fifty-two chronometers."

The fitting of the Arctic ships *Alert* and *Discovery* is making rapid progress at Portsmouth, in the hands of the dockyard shipwrights, who are working extra hours, in order that they may be rigged and out of their hands by the 12th of April. The sledges have all been made, and the tents are in progress. Meanwhile the officers are pursuing their special studies. We understand that Commander Markham, and Lieutenants Archer, Giffard, and Fulford are going through a course of instruction in magnetism. Lieutenants Parr and May are to be initiated into some special astronomical work, and two other lieutenants will receive charge of the pendulum observations. The work connected with spectrum analysis will also be provided for, and one or more of the officers will take up photography. The ships will be commissioned in the middle of April, and will sail early in June.

PROF. ROBERT WILLIS, M.A., F.R.S., Jacksonian Professor of Natural and Experimental Philosophy in the University of Cambridge, died on Sunday night. The late professor graduated at Gonville and Caius College in 1826, coming out ninth wrangler, and was elected a fellow of his College. He was appointed to the above professorship in 1837. He had been President of the British Association, and was member of the Board of Visitors of the Royal Observatory, Greenwich. The professorship vacant by the death of Mr. Willis is worth 300*l.* per annum. The professor is elected by the persons whose names are on the electoral roll of the University.

MR. E. RAY LANKESTER, M.A., Fellow of Exeter College, Oxford, has been elected to the Professorship of Zoology and Comparative Anatomy in University College, London, rendered vacant by the death of Dr. Grant.

MR. J. R. BLAKE, M.A., F.G.S., has been elected to the lectureship on Zoology and Comparative Anatomy at Charing Cross Hospital Medical School.

IN connection with the Loan Exhibition of Scientific Apparatus, meetings have been recently held at the South Kensington Museum, of the sub-committees for the sections of Mechanics, Physics, Chemistry, Geology, and Biology. The limits of the exhibition and various details connected with it were discussed, and recommendations prepared for submission to the General Committee at its next meeting.

It is announced that the Queen has, on the recommendation of the Prime Minister, granted a pension of 200*l.* a year to Mr. Wood, in recognition of his labours at Ephesus.

THE Queen has been pleased to approve of the following appointments to Companionships of the Order of St. Michael and St. George:—Mr. Augustus Charles Gregory, Surveyor-General of Queensland, who formerly rendered important and valuable services in connection with the exploration at Northern Australia; Mr. Walter Lowry Buller, the well-known ornithologist, author of "The Birds of New Zealand;" and Major

Peter Egerton Warburton, of South Australia, who lately conducted important explorations in that colony and Western Australia.

IN his last report of the progress and prospects of the cultivation of various useful trees in India, Dr. King speaks of the caoutchouc-yielding trees and the difficulties attending their cultivation. But his account of the Assam indiarubber tree, *Ficus elastica*, whose large glossy foliage is familiar to almost everybody in this country, excites some surprise. He writes: "The rubber of this country (India) is obtained from fig-trees, most of which (at least in early life) are parasitical [by which he means, of course, *epiphytical*]. These figs begin life by establishing themselves on the tops of other trees, along the trunks of which they send their twining aerial roots, which ultimately reach the ground. In course of time the supporting trees are killed, but the figs remain and grow, often entirely obliterating their predecessors. It is from the long aerial roots that the rubber is mostly got, and not from the branches. After a few severe tapings a fig ceases to yield rubber from its roots. The number of rubber trees, even in a country like Assam, is limited, and it is easy to foresee their early exhaustion. It is true it is also easy to propagate these figs by cuttings, but plants produced from cuttings put into the soil cannot very well have aerial roots, and may consequently be expected to yield little, if any, rubber. The artificial formation of indiarubber plantations on the summits of tall forest trees is obviously impracticable." Now, it has long been known that these indiarubber trees are epiphytical, but it seems far more probable that the mode of growth referred to simply renders it difficult to extract the caoutchouc until the roots come down within reach, not that they represent the principal seat of its secretion. Indeed, if this really be the case, it seems quite inexplicable, for this secretion pervades the whole system. However, it can be only partially true. The aerial roots of *Ficus elastica* are not only produced from the epiphytical examples, but also from those growing in the ground. Mr. Mann and other writers describe them as running along for a distance of thirty or forty feet on the surface of the soil, and mention the fact that the collectors tap the lower parts of the stem and these trailing roots. Looking into Mr. Mann's report on the same subject, he specially mentions the reckless felling of large trees to obtain the caoutchouc more readily; and in reference to the cultivation of the tree in question, he says that planted trees would yield at half the age a naturally grown tree would, as in the latter case several years elapse before an aerial root can reach the ground and establish itself. Dr. King's argument in favour of growing the Para caoutchouc, *Hevea brasiliensis*, on this ground must fall through; but as the latter is reported to furnish the best quality of caoutchouc, there is a good reason for attempting its cultivation.

DR. KALENDER, of Linderhöhe, near Cologne, gives an elaborate account, in the *Königliche Zeitung*, of the new enemy to the potato which has caused such ravages in the potato plantations of the United States, namely, the Colorado Beetle (*Doryphora decemlineata*). The general opinion on this beetle is rather uncertain at present, some considering it almost harmless, while others attach great importance to its being prevented from visiting Europe. Dr. Kalender applied to the Prussian Minister for Agriculture, and obtained the most reliable information, which is based upon a report of Mr. C. Riley, in the "Annual Report on the Noxious, Beneficial, and other Insects in the State of Missouri." It appears that the insect passes the winter in the ground, but as soon as the potato plants have developed their first shoots the beetle shows itself. The females then deposit their orange-coloured ova, in lumps of ten to twelve, upon the under surfaces of the leaves; and the larvae appear after five to eight days, and begin their destructive work, which lasts two or three weeks, after which period they trans-

form into nymphæ; ten to fourteen days later the young beetles appear; thus one summer can see three or four generations, of which the last one passes the winter in the ground. The insect does not confine its devastations to the potato only, but has also been found to attack the young shoots and leaves of *Cirsium lanceolatum*, *Amaranthus retroflexus*, *Lysimachium officinale*, *Polygonum hydrophyllum*, *Solanum nigrum*, *Chenopodium hybridum* and *album*, and even of *Hyoscyamus niger*. This variety of plants shows that the insect has great powers of adapting itself to its food, and to this it must be ascribed that it can only with the greatest difficulty be got rid of. The home of the insect was in the Rocky Mountains; with the westward progress of agriculture the cultivation of the potato approached the birth-place of the insect, and it transferred its dwelling to the potato fields, which of course were welcome food; thus in a short time it became a general plague. In 1859 it began its eastward progress, and has now reached the coast of the Atlantic; whether it will cross this ocean and begin its devastations in Ireland remains to be seen; but much may, however, be done to prevent its appearance in Europe. The means used for its destruction are various; the most successful one has been the so-called Schweinfurt green (arseno-acetate of copper). This is mixed with flour and water, and the plants are sprinkled with the mixture. Although highly poisonous to animal life, the Schweinfurt green does not poison the soil, as it is perfectly insoluble in water, and the destruction of the noxious insect is almost complete. Dr. Kalender finally draws the attention of agriculturists to another potato enemy, the *Brytostopa solanella*, a minute moth which has made its appearance in Algeria; its larvæ completely destroy the potatoes themselves, so that they become unfit even for pigs' food. The *Journal de la Société Centrale d'Horticulture en France* warns seriously against the importation of Algerian potatoes.

DON PEDRO, Emperor of Brazil, has been elected a corresponding member of the French Academy of Sciences for the section of Geography and Navigation. Don Pedro is the third emperor who has been a member of the Academy. The first was Peter the Great, elected a geographical correspondent. In that capacity he sent a map of the Caspian Sea, which is still kept in the records of the Academy. The second imperial Academician was Napoleon I., who was a member of the section of Mechanics, but resigned after his abdication at Fontainebleau. Napoleon III. tried to get appointed a member, but was not successful.

THE Academy of Sciences lost one of its most celebrated home correspondents in the same week as it did Lyell—a foreign correspondent. On the 1st inst., M. Frémy, the President, announced the demise of M. Seguin the elder, at the age of eighty-nine. M. Seguin was educated by his elder brother, and was himself a most daring engineer. He was the contractor of the Lyons and Saint Etienne Railway in 1825, a railway which was worked by horses and ropes for years. He is believed in France to have invented suspension bridges. He maintained at his own expense, during twenty years, the publication of *Cosmos*, a scientific periodical in which he expounded his own ideas on the doctrine of the conservation of force, of which he was a keen and active supporter.

AN exploring expedition will shortly leave Marseilles to make researches into the depths and animal organisations of the Mediterranean. Soundings and dredgings similar to those made by the *Challenger* will be made by a steamer specially provided with microscopes, photographic apparatus, and means for preserving new or rare specimens of marine zoology. The expedition is entirely due to private enterprise.

THE International Conference on the Metrical System met at Paris on Monday under the presidency of the Duc Decazes,

who explained that the object of the Conference was the conclusion of a Convention between States adopting or permitting the use of the metre as the basis of measurement. The Conference has transferred the solution of the questions to be decided to a Commission composed of delegates of the various Governments. M. Dumas, the Permanent Secretary to the Academy of Sciences, has been appointed President of this Commission, Mr. Chisholm being the English delegate.

M. LEVERRIER has established in the Paris Observatory a registry, where all the scientific facts collected from the several political papers may be cut and labelled. Such a register was kept during the last year of Arago's superintendence, but has been discontinued for years.

ON the 23rd of February the Italian Geographical Society discussed the advisability of sending an Italian expedition *vis à vis* the Red Sea to the sources of the Nile. The members were unanimous in favour of the scheme, and a programme will be issued shortly.

THE picturesque city of Caub, in Nassau, near Barharach, will very shortly, it is said, be crushed and destroyed by the disintegration of the mountain on which Guterfeld Castle was built in medieval times. The rocks which threaten Caub are not less than 600 feet in height. Two rows of houses have been deserted, as no human power can prevent the catastrophe.

SEVERAL continental papers note the fall of ponderous rocks caused by the recent frosty weather. Such occurrences as that referred to in our last number as having occurred at Moen are very frequent on the banks of the Seine. *La Nature* publishes a sketch taken at Sainte Adresse, near Havre, illustrating the progressive levelling of these lofty cliffs partly by the action of the waves, and partly by weathering.

ON Feb. 18 Dr. Gerhard Rohlfs delivered a lecture at Cologne on the last part of his journey from Tripoli to the coast of Guinea, which is of particular scientific interest. He treated in detail the state of civilisation of the Empire of Bornu (situated near Lake Tsad) and its capital, Kuka, and it appears that the negro tribes that inhabit those parts are highly civilised, in fact much more so than most other tribes in Northern Africa. From Kuka Dr. Rohlfs went to Mandara, which is situated south of Bornu, and then entered the districts of the Pullo (or Fullo) tribes; he found the inhabitants to be of light yellow, almost white complexion, and surpassing even Europeans with regard to beauty of form and growth. Dr. Rohlfs then descended the Tshadda River, down to where this joins the Niger, and was hospitably received by the English colonists at Lokoja; from here he visited a negro country in a western direction, then passed the Kong Mountains, and successfully traced his way through the thick tropical forests to the coast, which he reached near Lagos.

THE first annual meeting of the Scientific Club was held on Thursday, the 18th inst., Capt. Marshall Hall, F.G.S., in the chair, when a report was presented showing the great progress which has been made since the foundation of the club on the 19th of March last.

THE additions to the Zoological Society's Gardens during the past week include two Wild Boars (*Sus scrofa*), European, presented by Mr. Sebastian Anderson; a Grey Ichneumon (*Herpestes griseus*) from India, presented by Miss R. Barter; a Common Raccoon (*Procyon lotor*) from North America, presented by Miss Julia Jackson; a Herring Gull (*Larus argentatus*), European, presented by Miss Jessie Bovill; two Pet's Conures (*Conurus pectii*) from Peru, presented by Miss Hornby; two Sarus Cranes (*Grus anti-one*) from North India; a Mandarin Duck (*Aix galericulata*) from China, received in exchange; three Common Peafowl (*Pavo cristata*) from India, deposited.

ON THE DYNAMICAL EVIDENCE OF THE MOLECULAR CONSTITUTION OF BODIES\*

WHEN any phenomenon can be described as an example of some general principle which is applicable to other phenomena, that phenomenon is said to be explained. Explanations, however, are of very various orders, according to the degree of generality of the principle which is made use of. Thus the person who first observed the effect of throwing water into a fire would feel a certain amount of mental satisfaction when he found that the results were always similar, and that they did not depend on any temporary and capricious antipathy between the water and the fire. This is an explanation of the lowest order, in which the class to which the phenomenon is referred consists of other phenomena which can only be distinguished from it by the place and time of their occurrence, and the principle involved is the very general one that place and time are not among the conditions which determine natural processes. On the other hand, when a physical phenomenon can be completely described as a change in the configuration and motion of a material system, the dynamical explanation of that phenomenon is said to be complete. We cannot conceive any further explanation to be either necessary, desirable, or possible, for as soon as we know what is meant by the words configuration, motion, mass, and force, we see that the ideas which they represent are so elementary that they cannot be explained by means of anything else.

The phenomena studied by chemists are, for the most part, such as have not received a complete dynamical explanation.

Many diagrams and models of compound molecules have been constructed. These are the records of the efforts of chemists to imagine configurations of material systems by the geometrical relations of which chemical phenomena may be illustrated or explained. No chemist, however, professes to see in these diagrams anything more than symbolic representations of the various degrees of closeness with which the different components of the molecule are bound together.

In astronomy, on the other hand, the configurations and motions of the heavenly bodies are on such a scale that we can ascertain them by direct observation. Newton proved that the observed motions indicate a continual tendency of all bodies to approach each other, and the doctrine of universal gravitation which he established not only explains the observed motions of our system, but enables us to calculate the motions of a system in which the astronomical elements may have any values whatever.

When we pass from astronomical to electrical science, we can still observe the configuration and motion of electrified bodies, and thence, following the strict Newtonian path, deduce the forces with which they act on each other; but these forces are found to depend on the distribution of what we call electricity. To form what Gauss called a "construirbar Vorstellung" of the invisible process of electric action is the great desideratum in this part of science.

In attempting the extension of dynamical methods to the explanation of chemical phenomena, we have to form an idea of the configuration and motion of a number of material systems, each of which is so small that it cannot be directly observed. We have, in fact, to determine, from the observed external actions of an unseen piece of machinery, its internal construction.

The method which has been for the most part employed in conducting such inquiries is that of forming an hypothesis, and calculating what would happen if the hypothesis were true. If these results agree with the actual phenomena, the hypothesis is said to be verified, so long, at least, as some one else does not invent another hypothesis which agrees still better with the phenomena.

The reason why so many of our physical theories have been built up by the method of hypothesis is that the speculators have not been provided with methods and terms sufficiently general to express the results of their induction in its early stages. They were thus compelled either to leave their ideas vague and therefore useless, or to present them in a form the details of which could be supplied only by the illegitimate use of the imagination.

In the meantime the mathematicians, guided by that instinct which teaches them to store up for others the irrepressible secretions of their own minds, had developed with the utmost generality the dynamical theory of a material system.

\* A lecture delivered at the Chemical Society, Feb. 18, by Prof. Clerk-Maxwell, F.R.S.

Of all hypotheses as to the constitution of bodies, that is surely the most warrantable which assumes no more than that they are material systems, and proposes to deduce from the observed phenomena just as much information about the conditions and connections of the material system as these phenomena can legitimately furnish.

When examples of this method of physical speculation have been properly set forth and explained, we shall hear fewer complaints of the looseness of the reasoning of men of science, and the method of inductive philosophy will no longer be derided as mere guess-work.

It is only a small part of the theory of the constitution of bodies which has as yet been reduced to the form of accurate deductions from known facts. To conduct the operations of science in a perfectly legitimate manner, by means of methodised experiment and strict demonstration, requires a strategic skill which we must not look for, even among those to whom science is most indebted for original observations and fertile suggestions. It does not detract from the merit of the pioneers of science that their advances, being made on unknown ground, are often cut off, for a time, from that system of communications with an established base of operations, which is the only security for any permanent extension of science.

In studying the constitution of bodies we are forced from the very beginning to deal with particles which we cannot observe. For whatever may be our ultimate conclusions as to molecules and atoms, we have experimental proof that bodies may be divided into parts so small that we cannot perceive them.

Hence, if we are careful to remember that the word particle means a small part of a body, and that it does not involve any hypothesis as to the ultimate divisibility of matter, we may consider a body as made up of particles, and we may also assert that in bodies or parts of bodies of measurable dimensions, the number of particles is very great indeed.

The next thing required is a dynamical method of studying a material system consisting of an immense number of particles, by forming an idea of their configuration and motion, and of the forces acting on the particles, and deducing from the dynamical theory those phenomena which, though depending on the configuration and motion of the invisible particles, are capable of being observed in visible portions of the system.

The dynamical principles necessary for this study were developed by the fathers of dynamics, from Galileo and Newton to Lagrange and Laplace; but the special adaptation of these principles to molecular studies has been to a great extent the work of Prof. Clausius of Bonn, who has recently laid us under still deeper obligations by giving us, in addition to the results of his elaborate calculations, a new dynamical idea, by the aid of which I hope we shall be able to establish several important conclusions without much symbolical calculation.

The equation of Clausius, to which I must now call your attention, is of the following form:—

$$pV = \frac{2}{3} T - \frac{2}{3} \Sigma \Sigma (\frac{1}{2} Rr).$$

Here  $p$  denotes the pressure of a fluid, and  $V$  the volume of the vessel which contains it. The product  $pV$ , in the case of gases at constant temperature, remains, as Boyle's Law tells us, nearly constant for different volumes and pressures. This member of the equation, therefore, is the product of two quantities, each of which can be directly measured.

The other member of the equation consists of two terms, the first depending on the motion of the particles, and the second on the forces with which they act on each other.

The quantity  $T$  is the kinetic energy of the system, or, in other words, that part of the energy which is due to the motion of the parts of the system.

The kinetic energy of a particle is half the product of its mass into the square of its velocity, and the kinetic energy of the system is the sum of the kinetic energy of its parts.

In the second term,  $r$  is the distance between any two particles, and  $R$  is the attraction between them. (If the force is a repulsion or a pressure,  $R$  is to be reckoned negative.)

The quantity  $\frac{1}{2} Rr$ , or half the product of the attraction into the distance across which the attraction is exerted, is defined by Clausius as the virial of the attraction. (In the case of pressure or repulsion, the virial is negative.)

The importance of this quantity was first pointed out by Clausius, who, by giving it a name, has greatly facilitated the application of his method to physical exposition.

The virial of the system is the sum of the virials belonging to every pair of particles which exist in the system. This is ex-



pressed by the double sum  $\Sigma \Sigma (\frac{1}{2} Rr)$ , which indicates that the value of  $\frac{1}{2} Rr$  is to be found for every pair of particles, and the results added together.

Clausius has established this equation by a very simple mathematical process, with which I need not trouble you, as we are not studying mathematics to-night. We may see, however, that it indicates two causes which may affect the pressure of the fluid on the vessel which contains it: the motion of its particles, which tends to increase the pressure, and the attraction of its particles, which tends to diminish the pressure.

We may therefore attribute the pressure of a fluid either to the motion of its particles or to a repulsion between them.

Let us test by means of this result of Clausius the theory that the pressure of a gas arises entirely from the repulsion which one particle exerts on another, these particles, in the case of gas in a fixed vessel, being really at rest.

In this case the virial must be negative, and since by Boyle's Law the product of pressure and volume is constant, the virial also must be constant, whatever the volume, in the same quantity of gas at constant temperature. It follows from this that  $Rr$ , the product of the repulsion of two particles into the distance between them, must be constant, or in other words that the repulsion must be inversely as the distance, a law which Newton has shown to be inadmissible in the case of molecular forces, as it would make the action of the distant parts of bodies greater than that of contiguous parts. In fact, we have only to observe that if  $Rr$  is constant, the virial of every pair of particles must be the same, so that the virial of the system must be proportional to the number of pairs of particles in the system—that is, to the square of the number of particles, or in other words to the square of the quantity of gas in the vessel. The pressure, according to this law, would not be the same in different vessels of gas at the same density, but would be greater in a large vessel than in a small one, and greater in the open air than in any ordinary vessel.

The pressure of a gas cannot therefore be explained by assuming repulsive forces between the particles.

It must therefore depend, in whole or in part, on the motion of the particles.

If we suppose the particles not to act on each other at all, there will be no virial, and the equation will be reduced to the form

$$Vp = \frac{2}{3} T.$$

If  $M$  is the mass of the whole quantity of gas, and  $c$  is the mean square of the velocity of a particle, we may write the equation—

$$Vp = \frac{1}{3} Mc^2$$

or in words, the product of the volume and the pressure is one-third of the mass multiplied by the mean square of the velocity. If we now assume, what we shall afterwards prove by an independent process, that the mean square of the velocity depends only on the temperature, this equation exactly represents Boyle's Law.

But we know that most ordinary gases deviate from Boyle's Law, especially at low temperatures and great densities. Let us see whether the hypothesis of forces between the particles, which we rejected when brought forward as the sole cause of gaseous pressure, may not be consistent with experiment when considered as the cause of this deviation from Boyle's Law.

When a gas is in an extremely rarefied condition, the number of particles within a given distance of any one particle will be proportional to the density of the gas. Hence the virial arising from the action of one particle on the rest will vary as the density, and the whole virial in unit of volume will vary as the square of the density.

Calling the density  $\rho$ , and dividing the equation by  $V$ , we get—

$$p = \frac{2}{3} \rho c^2 - \frac{2}{3} A \rho^2$$

where  $A$  is a quantity which is nearly constant for small densities.

Now, the experiments of Regnault show that in most gases, as the density increases the pressure falls below the value calculated by Boyle's Law. Hence the virial must be positive; that is to say, the mutual action of the particles must be in the main attractive, and the effect of this action in diminishing the pressure must be at first very nearly as the square of the density.

On the other hand, when the pressure is made still greater the substance at length reaches a state in which an enormous increase of pressure produces but a very small increase of density.

This indicates that the virial is now negative, or, in other words, the action between the particles is now, in the main, repulsive. We may therefore conclude that the action between two particles at any sensible distance is quite insensible. As the particles approach each other the action first shows itself as an attraction, which reaches a maximum, then diminishes, and at length becomes a repulsion so great that no attainable force can reduce the distance of the particles to zero.

The relation between pressure and density arising from such an action between the particles is of this kind.

As the density increases from zero, the pressure at first depends almost entirely on the motion of the particles, and therefore varies almost exactly as the pressure, according to Boyle's Law. As the density continues to increase, the effect of the mutual attraction of the particles becomes sensible, and this causes the rise of pressure to be less than that given by Boyle's Law. If the temperature is low, the effect of attraction may become so large in proportion to the effect of motion that the pressure, instead of always rising as the density increases, may reach a maximum, and then begin to diminish.

At length, however, as the average distance of the particles is still further diminished, the effect of repulsion will prevail over that of attraction, and the pressure will increase so as not only to be greater than that given by Boyle's Law, but so that an exceedingly small increase of density will produce an enormous increase of pressure.

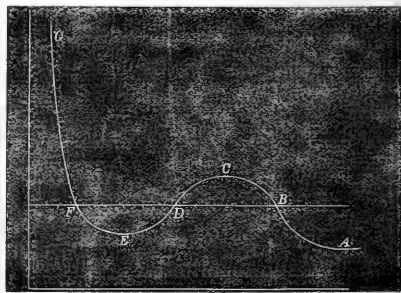

Hence the relation between pressure and volume may be represented by the curve  $ABCDEF G$ , where the horizontal ordinate represents the volume, and the vertical ordinate represents the pressure.

As the volume diminishes, the pressure increases up to the point  $C$ , then diminishes to the point  $E$ , and finally increases without limit as the volume diminishes.

We have hitherto supposed the experiment to be conducted in such a way that the density is the same in every part of the medium. This, however, is impossible in practice, as the only condition we can impose on the medium from without is that the whole of the medium shall be contained within a certain vessel. Hence, if it is possible for the medium to arrange itself so that part has one density and part another, we cannot prevent it from doing so.

Now the points  $B$  and  $F$  represent two states of the medium in which the pressure is the same but the density very different. The whole of the medium may pass from the state  $B$  to the state  $F$ , not through the intermediate states  $CDE$ , but by small successive portions passing directly from the state  $B$  to the state  $F$ . In this way the successive states of the medium as a whole will be represented by points on the straight line  $BF$ , the point  $B$  representing it when entirely in the rarefied state, and  $F$  representing it when entirely condensed. This is what takes place when a gas or vapour is liquefied.

Under ordinary circumstances, therefore, the relation between pressure and volume at constant temperature is represented by the broken line  $ABFG$ . If, however, the medium when liquefied is carefully kept from contact with vapour, it may be preserved in the liquid condition and brought into states represented by the portion of the curve between  $F$  and  $E$ . It is also possible that methods may be devised whereby the vapour may be prevented from condensing, and brought into states represented by points in  $BC$ .

The portion of the hypothetical curve from *C* to *E* represents states which are essentially unstable, and which cannot therefore be realised.

Now let us suppose the medium to pass from *B* to *F* along the hypothetical curve *BCDEF* in a state always homogeneous, and to return along the straight line *FB* in the form of a mixture of liquid and vapour. Since the temperature has been constant throughout, no heat can have been transformed into work. Now the heat transformed into work is represented by the excess of the area *FDE* over *BCD*. Hence the condition which determines the maximum pressure of the vapour at given temperature is that the line *BF* cuts off equal areas from the curve above and below.

The higher the temperature, the greater the part of the pressure which depends on motion; as compared with that which depends on forces between the particles. Hence, as the temperature rises, the dip in the curve becomes less marked, and at a certain temperature the curve, instead of dipping, merely becomes horizontal at a certain point, and then slopes upward as before. This point is called the critical point. It has been determined for carbonic acid by the masterly researches of Andrews. It corresponds to a definite temperature, pressure and density.

At higher temperatures the curve slopes upwards throughout, and there is nothing corresponding to liquefaction in passing from the rarest to the densest state.

The molecular theory of the continuity of the liquid and gaseous states forms the subject of an exceedingly ingenious thesis by Mr. Johannes Diderik van der Waals,\* a graduate of Leyden. There are certain points in which I think he has fallen into mathematical errors, and his final result is certainly not a complete expression for the interaction of real molecules, but his attack on this difficult question is so able and so brave, that it cannot fail to give a notable impulse to molecular science. It has certainly directed the attention of more than one inquirer to the study of the Low-Dutch language in which it is written.

The purely thermodynamical relations of the different states of matter do not belong to our subject, as they are independent of particular theories about molecules. I must not, however, omit to mention a most important American contribution to this part of thermodynamics by Prof. Willard Gibbs,† of Yale College, U.S., who has given us a remarkably simple and thoroughly satisfactory method of representing the relations of the different states of matter by means of a model. By means of this model, problems which had long resisted the efforts of myself and others may be solved at once.

J. CLERK-MAXWELL

(To be continued.)

## SOCIETIES AND ACADEMIES

LONDON

Geological Society, Feb. 19.—Annual General Meeting.—Mr. John Evans, V.P.R.S., president, in the chair.—The Secretary read the reports of the Council and of the Library and Museum Committee. The general position of the Society was described as satisfactory, although, owing to extraordinary expenses during the year, the excess of income over expenditure was but small in comparison with former years. The Society was said to be prosperous, and the number of Fellows to be rapidly increasing.

In presenting the Wollaston Gold Medal to Prof. de Koninck, of Liège, F.M.G.S., the President addressed him as follows:—"Monsieur le Docteur de Koninck, it is my pleasing duty to place in your hands the Wollaston Medal, which has been awarded to you by the Council of this Society in recognition of your extensive and valuable researches and numerous geological publications, especially in Carboniferous Palæontology. These researches are so well known, and have gained you so worldwide a reputation, that I need say no more than that your palæontological works must of necessity be almost daily consulted by all who are interested in the fauna of the Carboniferous period. Already in 1853 the numerous and able Palæontological works which you had published in the preceding twenty years had attracted the grateful notice of the Council of this

Society, who in that year begged you to accept the balance of the proceeds of the Wollaston Fund, in aid of the publication of your work on Encrinites, then in progress. It was in the same year that the Society had the satisfaction of electing you a Foreign Member of their body; and now, after a second period of rather more than twenty years devoted to the study not only of geology and palæontology, but also of chemical analysis, I have the pleasure of conferring upon you the highest additional honour it lies in the power of this Society to bestow, by presenting you with the medal founded by the illustrious Wollaston, who was himself also a chemist as well as a geologist. If anything could add to the satisfaction we feel in thus bestowing the medal, it is your presence among us this day, which will enable you more fully to appreciate our unanimous sense of the high value of your labours in the cause which we all have at heart."

The President then presented the balance of the proceeds of the Wollaston Donation Fund to Mr. L. C. Miall, of Leeds, and addressed him in the following terms:—"Mr. Miall, I have much pleasure in presenting you with the balance of the proceeds of the Wollaston Fund, which has been awarded you by the Council of this Society to assist you in your researches on Fossil Reptilia. Those who had the good fortune to be present at the meeting of the British Association at Bradford in 1873, and to hear the masterly report of the Committee on the Labyrinthodonts of the Coal-measures, drawn up by yourself, and those also who have studied the papers which you have communicated to this Society on the Remains of Labyrinthodonta from the Keuper Sandstone of Warwick, must be well aware of the thorough and careful nature of your researches, carried on, I believe, in a somewhat isolated position, and remote from those aids which are so readily accessible in the metropolis and some of our larger towns. I trust that the proceeds of this fund which I have now placed in your hands will be regarded as a testimony of the interest which this Society takes in your labours, and may also prove of some assistance to you in still further prosecuting them."

Mr. Miall, in reply, said that he felt that his sincere thanks were due to the Geological Society for awarding him the balance of the proceeds of the Wollaston Donation Fund as a token of appreciation of the little work that he had been able to do, and also to the President for the terms in which he had been kind enough to speak of him. He should regard this donation, not only as an honour received by him, but also as a trust to be expended to the best of his power in accordance with the intentions with which it had been conferred upon him by the Society.

The President next handed the Murchison Medal to Mr. David Forbes for transmission to Mr. W. J. Henwood, F.R.S., and spoke as follows:—"Mr. David Forbes, in placing the Murchison Medal and the accompanying cheque in your hands, to be conveyed to our distinguished Fellow, Mr. William Jory Henwood, I must request you to express to him our great regret that he is unable to attend personally to receive it. His researches on the metalliferous deposits, not only of Cornwall and Devonshire, but of Ireland, Wales, North-western India, North America, Chili, and Brazil, extending as they do to questions of subterranean temperature, electric currents, and the quantities of water present in mines, are recorded in memoirs which form text-books for mining students. They have for the most part been contributed to the Royal Geological Society of Cornwall, which has taken a pride in publishing them; but I trust that it will be a source of satisfaction to Mr. Henwood, after fifty years of laborious research, and amidst the physical suffering caused by a protracted illness, to receive this token of appreciation at the hands of another Society which takes no less interest in the subjects of his investigations."

Mr. David Forbes said that in receiving the Murchison Medal, on behalf of Mr. W. J. Henwood, he was commissioned by that gentleman to express his great regret that the bad state of his health and his advanced age prevented his appearing in person to thank the Council for the high honour they had conferred upon him, and the extreme gratification he felt in finding that the results of his labours in the investigation of the phenomena of mineral veins, which had extended over more than fifty years, had thus been recognised by the Geological Society of London.

The President then presented to Prof. H. G. Seeley the balance of the Murchison Geological Fund, and said:—"Mr. Seeley, your researches in geology and on fossil osteology have already extended over a period of upwards of sixteen years, and the numerous and valuable essays which you have contributed to the Annals and Magazine of Natural History, as well

\* Over de continuïteit van den gas en vloeistof toestand. Leiden: A. W. Sijthoff, 1873.

† "A method of geometrical representation of the thermodynamic properties of substances by means of surfaces." Transactions of the Connecticut Academy of Arts and Sciences, Vol. ii. Part 2.

as to the Quarterly Journal of this Society, are only a portion of their fruits. Your separate works on the fossil remains of Aves, Ornithosauria, and Reptilia, in the Woodwardian Museum at Cambridge, and on the bones of Pterodactyles, are well known to every student of fossil osteology, and have been thought worthy of the by no means empty compliment of being printed at the expense of the Syndics of the University Press of Cambridge. The esteem in which your researches are held by the Council of this Society, and their hope that you may still be enabled to prosecute them, are best evinced by their presenting you with the balance of the proceeds of the Murchison Fund, which I now have the pleasure of placing in your hands."

Prof. Seeley replied as follows:—"Mr. President, I have ever been taught that the Geological Society is the fountain of geological honour. It has always been a great honour to be associated with the Fellows of this Society, who are constructing the sciences we cultivate. Out of this association have grown bonds of comradeship, encouraging some of us to follow on in the labour of those whose work is ended; and when, sir, I receive at your hands this award of the balance of the Murchison Fund, I am grateful for such a distinguished mark of sympathy with my special studies, and shall be encouraged by it to prosecute researches which I hope may be better worthy of the Society's acceptance."

The President then proceeded to read his Anniversary Address, in which, after congratulating the Fellows upon their having at length got possession of their new premises, he called attention to the advantage which accrued both to the Fellows of the Society and to the officers of the School of Mines, Geological Survey, and Museum of Practical Geology, by the close proximity of the two establishments, and expressed a hope that there might be no severance of this union, whether by the removal of the School of Mines to South Kensington or otherwise. He also contrasted the position of the Society as regards funds, number of Fellows, &c., in 1829 and in 1875, the former being the first year in which the anniversary meeting of the Society was held in the Society's rooms at Somerset House. He then took up the main subject of his address, namely, the question of the antiquity of the human race, and the geological evidence bearing upon it. The address was prefaced by some obituary notices of Fellows and foreign members deceased during the past year, including Prof. Phillips, Dr. F. Stoliczka, the Rev. C. Kingsley, Mr. J. W. Pike, Dr. Arnott, Prof. W. Macdonald, M. Elie de Beaumont, and M. J. J. d'Omalius d'Halloy.

The ballot for the council and officers was taken, and the following were duly elected for the ensuing year:—President, John Evans, F.R.S. Vice-Presidents: Prof. P. Martin Duncan, F.R.S., Robert Etheridge, F.R.S., Sir Charles Lyell, Bart., F.R.S., Prof. A. C. Ramsay, F.R.S. Secretaries: David Forbes, F.R.S., Rev. T. Wiltshire, M.A. Foreign Secretary, Warrington W. Smyth, F.R.S. Treasurer, J. Gwyn Jeffreys, F.R.S. Council: H. Bauerman, Frederic Drew, Prof. P. Martin Duncan, F.R.S., Sir P. de M. G. Egerton, Bart., F.R.S., R. Etheridge, F.R.S., John Evans, F.R.S., David Forbes, F.R.S., R. A. C. Godwin-Austen, F.R.S., Henry Hicks, Prof. T. McKenny Hughes, M.A., J. W. Hulke, F.R.S., J. Gwyn Jeffreys, F.R.S., Sir Charles Lyell, Bart., F.R.S., C. J. A. Meyer, J. Carrick Moore, F.R.S., Prof. A. C. Ramsay, F.R.S., Samuel Sharp, F.S.A., Warrington W. Smyth, F.R.S., H. C. Sorby, F.R.S., Prof. J. Tennant, F.C.S., W. Whitaker, B.A., Rev. T. Wiltshire, F.L.S., Henry Woodward, F.R.S.

Victoria (Philosophical) Institute, March 1.—Mr. C. Brooke, F.R.S., in the chair.—A paper on the chronology of recent geology was read by Mr. S. R. Pattison, F.G.S. Mr. Pattison maintained that geology furnishes no proof, nor high probability, that the introduction of man into Europe took place longer ago than about six or seven thousand years.

PARIS

Academy of Sciences, Feb. 22.—M. M. Frémy in the chair.—The following papers were read:—A report, by M. Leverrier, on the meridian observations of the minor planets, made at the Greenwich and Paris Observatories during the last three months of 1874. The details are given for planets 69, 76, 91, 120, 11, 43, 83, 6, 78, 149, 10, 3, 2, 4, 5, 59, 81, 33, 46, and 49.—New observations of the nature of alcoholic fermentation, by M. L. Pasteur.—On ruthenium and its oxides, by MM. H. Sainte Claire Deville and H. Debray. These gentlemen had at their disposal a considerable quantity of ruthenium and

its compounds, and have made them the subject of elaborate investigations. Their report contains valuable details concerning this rare metal and its compounds; among them per Ruthenic acid, RuO<sub>4</sub>, is of particular interest, as up to the present it was hardly known; they obtained it in yellow crystals of such instability as to make it impossible to determine their form, their melting point was at 40° C. They also obtained several salts of this acid. At 108° it is decomposed under explosion.—On the simultaneous formation of several crystallised mineral species in the thermal source of Bourbonne-les-bains (Haute Marne), particularly of grey antimonial copper (tetrahydrate), copper pyrites (chalcopyrite), streaky copper (philippsite), and copper sulphide (chalcospine); by M. Daubrée.—On the action of borax in fermentation and putrefaction, by M. J. B. Schnetzler. This paper treats of three distinct actions of borax, viz., that upon protoplasm of vegetable cells, that upon mineral organisms, and that upon matter undergoing fermentation.—On the boiling of sulphuric acid, by M. A. Bobierre. The boiling of this acid is generally considered a difficult operation; the author shows that it is very easy and even more regular than that of water, if one introduces into the vessel holding the acid a sufficient quantity of platinum.—On the winter vegetation of Algæ at Mossel Bay (Spitzbergen), by M. F. Kjellman: observations made during the Swedish Polar Expedition of 1872-73. The author found that the Algæ at Mossel Bay during the winter are the same as those during the summer and autumn, and that the dark season in the winter, which lasts about three months and a half, makes little or no difference to this part of the vegetation. He gives a list of numerous species which he observed, belonging to the orders of *Coralinaceæ*, *Floridææ*, *Fucaeæ*, *Phaeosporaceæ*, and *Chlorosporaceæ*.—On the chemical composition of the *petit lait* of Luchon, by M. T. Garrigou. The author gives the analysis of these waters, which hold about 7 per cent. of solid matter partly in solution.—On a case of epilepsy treated with sulphate of copper, and the presence of a considerable quantity of copper in the liver, by MM. Bourneville and Yvon.—The Secretary read the following telegram, dated Aden, Feb. 16, 1875, from M. Mouchez, the chief of the expedition sent to observe the Transit of Venus. The telegram runs as follows:—"Three months of bad weather; transit rather fine; interior contacts excellent, exterior contacts cloudy; numerous photographs. *Dives* (the vessel carrying the material for the expedition) started for Cherbourg; all well."—A note by M. J. L. Soret, on the diffraction phenomena produced by circular nets.—On the influence of pressure upon combustion, by M. Cailletet.—On the impurities in boric acid, by M. A. Ditté.—A note by M. Béchamp on the *Microzymata* and *Bacteria*, with regard to a remark of M. Balard. This paper is a continuation of another one read before the Academy on Nov. 30 last, on the birth and evolution of *Bacteria* in organic tissues sheltered from the air, by M. Servel.—A note by M. Gayat on some comparative researches on man and animals with reference to the ophthalmoscopic signs of death.—M. J. Vioin then replied to a note of M. Chapelas, read at the last meeting, regarding a large bolide, which was supposed to have been an illuminated cloud, and proved that M. Chapelas' idea was erroneous.

CONTENTS

PAGE

SIR CHARLES LYELL, BART., F.R.S. . . . .	341
THE "HESSENER" . . . . .	342
THE ENCYCLOPEDIA BRITANNICA . . . . .	343
BROWN'S "MANUAL OF BOTANY" . . . . .	345
OUR BOOK SHELF:—	
Colonel Goldsmid's "Telegraph and Travel" . . . . .	347
LETTERS TO THE EDITOR:—	
Sir J. Herschel on Endowment of Research—J. F. W. H. . . . .	347
Trade Winds.—Prof. F. GUTHRIE, F.R.S. ( <i>With Illustrations</i> ) . . . . .	348
The Arctic Expedition.—R. J. MOSS . . . . .	348
Hercepath's Balance.—E. W. P. . . . .	348
OUR ASTRONOMICAL COLUMN:—	
The Binary Star $\beta^2$ BOOIS . . . . .	348
Falk's New Variable in Orion . . . . .	348
The Variable Star R Hydrae . . . . .	349
Winnecke's Comet . . . . .	349
The Zodiacal Light . . . . .	349
New Minor Planet . . . . .	349
SCIENCE AT THE NEW PARIS OPERA. By M. G. TISSANDIER ( <i>With Illustrations</i> ). . . . .	349
ENGLISH GOVERNMENT ECLIPSE EXPEDITION, 1875 . . . . .	351
SCHOLARSHIPS AND EXAMINATIONS FOR NATURAL SCIENCE AT CAMBRIDGE, 1875 . . . . .	353
NOTES . . . . .	354
ON THE DYNAMICAL EVIDENCE OF THE MOLECULAR CONSTITUTION OF BODIES. By Prof. CLERK-MAXWELL, F.R.S. ( <i>With Illustration</i> ). . . . .	357
SOCIETIES AND ACADEMIES . . . . .	359

THURSDAY MARCH 11, 1875

## AGRICULTURE IN VICTORIA

*Department of Lands and Agriculture, Victoria. Second Annual Report of the Secretary for Agriculture.* (Melbourne: Published by authority. John Ferres, Government Printer, 1874.)

THE Government of the flourishing colony of Victoria has had in active operation, for two years, a Department of Agriculture, the history, constitution, and working of which may be discussed with advantage at a time when it is proposed, in many quarters, to establish a somewhat similar department in the mother country.

The work done by the Victorian Department for 1873 is detailed in the Report sent to us by the Secretary. The origin of the Department is given in the Introduction to the First Report, which we happen to possess, and from which we learn that the Port Phillip Agricultural Society was instrumental in inducing the Legislature of the day to pass the Act, 22nd Victoria, No. 83, which established and endowed a Board of Agriculture for the colony. It would appear that the Board spent all its funds in making grants to local Agricultural Societies; and thus failed, as might have been expected, to produce results commensurate with the grant. This failure induced a number of thoughtful men to urge on the Government the propriety of establishing an independent department for promoting the agricultural interests. The executive received the matter favourably; and appointed, on the 19th of June, 1873, the Hon. J. J. Casey first Minister of Agriculture. It became necessary to appoint a permanent executive officer as head of the Department, and the course adopted for securing the services of such an officer was novel. It was called a competitive examination, but the competition was confined to an essay on the means of promoting the object. The examiners unanimously selected as the best the essay written by Mr. A. R. Wallis, who was at once appointed. Mr. Wallis holds the diploma of the Royal Agricultural College, Cirencester; and, fortunately for the colony, possesses essential qualities, such, *e.g.*, as energy, which could not be tested by the writing of an essay. The paper which secured the appointment for Mr. Wallis is published in the First Annual Report of the Department, and is the production of a thoughtful mind.

The first "Report" was made up chiefly of papers supplied by the Secretary himself. He had to discuss vine-culture, vine-disease, and other subjects which were new to him. On the whole, however, the volume was a respectable production.

In the Report for 1874 he was able to obtain papers on various agricultural subjects from the most competent men in the colony. The volume begins with the general report by the Secretary, himself, which is followed by a report from the pen of the recently appointed chemist, Mr. W. E. Ivey, and a report on the state forests apparently written by the same Mr. Ivey. In addition to these reports the volume contains a great many original papers on important subjects. On the whole, the volume is creditable to the Secretary, on whom the direction of the Department devolves. He is a young man. Every-

thing was new to him in his adopted country. He had to deal with subjects which he could not by any possibility have mastered at the time he entered on his duties. Viewing his labours in the light of this fact, they give promise of a useful career. The recent scientific training which Mr. Wallis received at Cirencester must have aided him in overcoming many difficulties. He would do well to exercise great caution. We would advise him, and all those who break new ground, to avoid disquisitions or discussions on subjects with which they are not thoroughly conversant. We find an instance in the Report for 1874. In suggesting the propriety of instituting an agricultural survey of Victoria, a thing in itself most useful, the Secretary writes a rank heresy in political economy. "It seems to me," he says, "a monstrous thing that a man who, by the combined application of industry, capital, and intelligence, has converted a barren schistose hill into a well-managed and productive vineyard, should be subject to a higher assessment than the person who owns or occupies the adjacent lands of equal natural fertility, or than one who owns a vast extent of the most naturally productive lands of the colony, because such lands are devoted to none other than pastoral purposes."

In writing this passage Mr. Wallis overlooked an elementary principle of taxation, namely, that as one of the objects of taxation is to create a fund for the protection of property, men should pay this tax in proportion to their property or ability to pay. A well-managed and, productive vineyard would be a source of loss to its owner if every dishonest man living in the colony of Victoria were allowed to seize the crop. It is unnecessary to waste time in elucidating so simple a matter. The wonder is, how a man of Mr. Wallis's intelligence and position could have entertained and expressed a view which is at variance alike with the elements of economic science and common sense. We fully believe the passage was written hurriedly and without thought. The subject was of the most incidental character; and there is a very general tendency to deal in an "offhand" manner with topics which arise in this way. The Secretary passes in review the leading crops and interests with which his department is concerned. We are sorry to learn that the experiments made with flax in various parts of the colony have not been satisfactory. The vine crop of 1874 was good, and it was comparatively free from disease. Fruit culture, entomology and meteorology, and a great many other subjects, are briefly noticed. The topic which appears to interest the Secretary most is agricultural education, which is treated at considerable length in a paper distinct from the Report. "It is high time," he says, "now that the Church, the Law, and the Sword have their Colleges supported by the State, that the Plough should have hers." And he urges that "it is as much a matter of national policy to teach the people how to feed men scientifically as to kill them." His paper on agricultural education is most interesting. Of his own Alma Mater, Cirencester, he speaks more reservedly than we could expect. His success, which we sincerely and ardently wish, will do more for Cirencester than mere words of praise. He describes its arrangements briefly and correctly. Of the Irish national system of agricultural education he speaks in the warmest terms. Through its

instrumentality, we are informed, the knowledge of the rotation of crops was introduced into districts where rotation cropping had been previously unknown, and where the potato and oats were the only crops formerly cultivated. Before embarking in any scheme of agricultural education, the people of Victoria would do well to study the "ups" and "downs" of this Irish system, which has been in operation for upwards of thirty years, and which, if report be true, is about being freely pruned by the Treasury. This Irish system of agricultural education is directed by a body of twenty Commissioners, of whom one is a paid administrator, nineteen being unpaid. We take it for granted that they and the Government of the day concur in the action of the Treasury. There is a widespread feeling that there are, or have been, men at the Treasury who are opposed to public grants for agricultural education, and who say there is no reason why farmers should be taught their business any more than shoemakers or carpenters.

But all that the best friends of agricultural education claim is, that the fundamental truths of agricultural science should be taught in our rural schools, and that there should be a few normal schools or colleges in which the best minds of the country could be thoroughly educated in the science of agriculture, so as to qualify them for making investigations, and for taking a leading part in agricultural progress. This is, according to our interpretation, all that the Secretary of the Agricultural Department of Victoria asks; and we trust the Government of Victoria will carry out his views. If they carefully study the several sides of the Irish system, they cannot fail to devise a system of agricultural education which would confer lasting benefits on the colony.

It has been already stated that Mr. Ivey contributes two papers, one on Chemistry and the other on the State Forests. It is not often that a man professes chemistry and forestry. Many a chemist is also a naturalist, and why should not a man study the habits of forest trees as well as those branches of knowledge included in natural history? Mr. Ivey's report on the forests is interesting, but his chemical report concerns us more. He gives us several chemical analyses of virgin soils, and endeavours to show that such analyses are of direct use to the farmer. We agree with Mr. Ivey when he says that the chemist, by discovering some compound in the soil unfavourable to crops, can afford the settler information which will save him from the loss of pitching his tent on a barren location. We must, however, assure Mr. Ivey that he pushes a little too far his argument in favour of the value of chemical analyses of soil. We have now before us a most remarkable sheet, drawn up by an advanced agriculturist, in which appear thirteen chemical analyses of soils and subsoils, and their rents of these soils, and we must say that we have never seen any return showing a great discordance between the indications of analyses and the judgment of men who know to a shade the actual value of land. If Mr. Ivey is ambitious to make his investigations in this department of chemistry of real use and benefit to the farmer, he must strike out a new line of thought. Until he does this he should, if he would retain the good opinion of men who are competent to form a correct estimate of his work, confine himself to these fields of labour in which there is

ample room for the application of the established principles of chemistry.

Mr. R. L. J. Ellery, F.R.S., Government Astronomer, contributes to the Report now under review an able and interesting report on the meteorology of Victoria. Many of the rising generation cast their thoughts on the colonies with a view to emigration; and to these Mr. Ellery's report must be instructive. In the following passage we get a general notion of the physical features of the country:—

"By an examination of a contoured plan of the colony, we find that the most prominent feature is an extensive mountain range running approximately east and west, rising somewhat abruptly about lat.  $37^{\circ} 30'$ , and long.  $141^{\circ} 40'$ , varying in altitude from 1,000 to 5,000 feet, and culminating in the N.E. in lat.  $36^{\circ} 30'$ , long.  $148^{\circ} 20'$ , at Mount Kosciusko, the highest part of Australian Alps, where it attains an altitude of over 7,000 feet. The higher parts of this range; are covered with snow for several months in the year. The mountain country is for the most part densely wooded with fine timber, even to the very summits; at some of the higher elevations, however, especially in the N.E., many of the peaks are quite bare, or only partially covered with dwarfed trees or shrubs. The country north and south of this great dividing range is moderately undulating or flat, consisting often of large plains, in some parts quite destitute of trees, but closely wooded in others. Along some parts of the coast-line, however, especially in the Cape Otway, Western Port, and Wilson's Promontory districts, the land rises to considerable altitude (from 2,000 to 3,000 feet) by ranges generally well covered by timber to their summits. On the whole, the country is not well watered; the rivers are few and insignificant and are often nearly dry in summer; there are several lakes, both salt and fresh, in different parts, but not of sufficient extent to have any marked influence on the climate. The coast-line itself is for the most part flat, with a moderate elevation; although, as just stated, at some places lofty ranges abut on the sea, and the coast becomes precipitous and rugged. An extensive sea-board, open to polar winds and oceanic currents, modified, no doubt, by the presence of the island of Tasmania, an extensive and wooded mountain range running across the whole breadth of the colony, the higher portions of which are often clothed in snow, and the generally arid sub-tropical Australian interior, dominating on its northern and western boundary, must each necessarily exercise considerable influence in producing conditions of climate varying with the locality."

The notion is generally entertained in these countries that the climate of Victoria is extremely dry. Mr. Ellery shows that the rainfall attains to the average of similar latitudes in other parts of the globe. He puts the average at 25.66 inches per annum. Spontaneous evaporation is, however, very great; and a large quantity of the rainfall is also lost in consequence of the vast area of the country which has been unbroken.

The mean temperature of the year is given as follows:—

Melbourne . . .	$57^{\circ} 5$	Bush Waste . . .	$57^{\circ} 2$
Portland . . .	$60^{\circ} 9$	Stawell . . .	$57^{\circ} 7$
Cape Otway . . .	$55^{\circ} 1$	Berwick . . .	$57^{\circ} 1$
Port Albert . . .	$56^{\circ} 4$	Daylesford . . .	$53^{\circ} 1$
Saba Island . . .	$58^{\circ} 6$	Heathcote . . .	$57^{\circ} 4$
Ararat . . .	$58^{\circ} 0$	Castlemaine . . .	$56^{\circ} 2$
Ballarat . . .	$53^{\circ} 6$	Camperdown . . .	$54^{\circ} 6$
Sandhurst . . .	$58^{\circ} 7$		

The minimum of heat occurs in June, July, and August. The lowest known at Melbourne is  $27^{\circ}$ , or  $5^{\circ}$  below the freezing-point; at Portland,  $27^{\circ}$ ; at Sandhurst,  $27^{\circ} 5$ , and at Ballarat,  $22^{\circ}$ .

The highest recorded temperature in the shade occurs at Sandhurst in June, and was  $117^{\circ}$ ; at Melbourne  $111^{\circ}$ . "There are other localities in which higher temperatures prevail in the same month, especially in the plains north of the dividing range, and along the banks of the Murray, in which the temperature has been as high as  $123^{\circ}$  to  $125^{\circ}$  for several days together. It is during the hot winds to which the climate is subject in summer that our highest temperatures occur, but they seldom last many hours, and are usually followed by a change in the direction of the wind, and by a comparatively low thermometer, when a fall of  $20^{\circ}$  to  $25^{\circ}$  often occurs in as many minutes."

We intended to make some remarks on the general advantages of a Department of Agriculture, but shall reserve them for a review of a similar volume which has come to us from the United States of America.

#### OUR BOOK SHELF

*The Pathological Significance of Nematode Hematozoa.*  
By T. R. Lewis, M.B., Staff-Surgeon H.M.B.F., on Special Duty. (Calcutta: 1874).

THIS little work may be regarded as a companion volume to Dr. Lewis's essay "On a Hematozoon in Human Blood." Both are reprints from the Annual Reports of the Sanitary Commissioner with the Government of India, for the years 1871 and 1873 respectively, and as such testify to the high class of scientific labour performed by the staff officers on special duty.

The main points brought out by Dr. Lewis are such as afford proof that chyluria (or a milky-looking condition of the urine) and the elephantoid state of the tissues are associated with the presence of a microscopic nematode entozoon in the human blood. Having fairly established that conclusion, he next proceeds to show that the disorders in question are immediately "due to the mechanical interruption to the flow of the nutritive fluid in the capillaries and lymphatics." No one who takes the trouble to look into the evidence so carefully collected by the author can fail to see that he has thrown a great deal of light upon the pathology of chyluria, elephantiasis, and other more or less closely allied morbid conditions; but Dr. Lewis has done more than this, for he has extended our knowledge of the habits and genetic relations of the microscopic hematozoa of the dog (so long a puzzle to helminthologists), and has shown that the so-called *Filaria sanguinis hominis* are perfectly distinct from the canine *filaria*, which latter, moreover, he proves to be the progeny of the *Filaria sanguinolenta*. Further than this, the author has detected numerous specimens of an aberrant type of nematode worm in the walls of the stomach of pariah dogs. These parasites occupy small tumours, two or more being usually coiled together in the centre of each swelling. He speaks of them as *Echino-rhynchii*, which, indeed, they somewhat resemble; but it is quite clear from the very admirable figures accompanying the description, that the worms are not members of the order *Acanthocephala*. They are, in fact, examples of the *Cheiracanthus robustus* hitherto found only in various species of *Felis*. The illustrations, throughout, are remarkably clear, and show the internal structure of the parasites to perfection.

T. S. COBBOLD

#### LETTERS TO THE EDITOR

[The Editor does not hold himself responsible for opinions expressed by his correspondents. Neither can he undertake to return, or to correspond with the writers of, rejected manuscripts. No notice is taken of anonymous communications.]

##### The Origin of the Jewish Week

MR. R. A. PROCTOR's paper on "Saturn and the Sabbath of the Jews," in the *Contemporary Review* of this month, reopens

one of the oldest and most interesting questions in the history of astronomy. Unfortunately, the writer is very imperfectly acquainted with the literature of his subject, and in consequence has, I think, imported not a little confusion into the discussion. That the week of seven days is directly connected with the worship of the seven planets known to the ancients, is a theory which has always had many supporters. It is at once suggested by the familiar names of the seven days, and would be absolutely proved if we could show that these names are as old as the division of the lunar month into four weeks. Again, it is also a well-known, though less wide-spread doctrine, that the Jewish Sabbath passed into Mosaicism from an earlier planetary religion. Of course, if it can be shown that the Sabbath was originally sacred to Saturn, we have a strong proof of the antiquity of the names of the week-days, and a probability that these names are as old as the seven day week itself. In this way a question in the history of Semitic religions comes to have an important bearing on a question in the history of astronomy. Mr. Proctor reverses the argument. He assumes that we have the clearest possible evidence that all nations that adopted the seven day week named the days after the planets, and did so in that peculiar order which is generally explained by assuming that a new planet presides over every successive hour of the week, and that each day takes the name of the planet of its first hour. It is then argued that Saturn, as the highest planet, was the supreme god of Assyria, and so also of the Egyptians who received their astrological lore from Chaldea. The Egyptians, we are told, certainly consecrated the seventh day of the week to Saturn, and since the Israelites left Egypt observing the Sabbath, while there is no evidence of a Sabbath in patriarchal times, "it is presumable that this day was a day of rest in Egypt." Now, whatever may be the ultimate solution of the problem of the origin and diffusion of the seven-day week, this theory rests partly on uncertain assumptions, partly on undoubted blunders. It is notorious that several Semitic nations, not to speak of the Peruvians, had a seven-day week without planetary names; so that Mr. Proctor's fundamental assumption begs the whole question. Then, again, it is the opinion of so great an authority as Lepsius that the Egyptians had no seven-day week, but divided the month into three decades. The passage of Dion Cassius from which the contrary opinion is drawn is certainly not decisive for ancient Egyptian usage, and Mr. Proctor seems to quote his author at second hand; for he asserts, in flat contradiction to Dion, that when the latter wrote, neither Greeks nor Romans used the week. For the supposition that Saturn was the supreme god of the Egyptians, not a shadow of proof is offered, while what is said of the Assyrian Saturn is directly in the teeth of the most recent researches. If Mr. Proctor had read Schrader's essay on the Babylonian origin of the week, he would have known that Adar or Saturn is quite distinct from the supreme god Asur. Thus, apart from the late and doubtful testimony of Dion, Mr. Proctor has no other evidence for his Egyptian theory of the week than that which he derives from the presumed non-existence of the Sabbath among the Hebrews before they entered Egypt. But the seven-day week appears in the narrative of the flood, which is certainly not an Egyptian legend. I say nothing of numerous minor inaccuracies in Mr. Proctor's paper, but repeat that the point on which new light requires to be thrown is whether it can be made out that the names of the seven days are as old as the week itself. This again seems to depend partly on the question whether the division of the day into twenty-four hours is older than the week, and partly on what can be determined as to early Egyptian and Chaldean subdivisions of the month. The Egyptians had a day of twenty-four hours; but had they a week? The Chaldeans may have had the week, but they seem to have divided the day (including the night) into twelve hours. Perhaps, however, it ought to be borne in mind that Dion gives another way of accounting for the names of the day, depending not on the division of the day into hours, but on the analogy of musical harmony (*ἡ ἀρμονία ἢ διὰ τεσσάρων*). The Jewish Sabbath can contribute little to the argument unless one is prepared with Lagarde to maintain that Shabbat is a name of Saturn.

W. R. SMITH

##### Kirkes' Physiology

I HAVE observed in your issue of Jan. 28 (vol. xi. p. 248) a letter in answer to some previous remarks of mine concerning the true function of the sinuses of Valsalva. Your correspondent, Mr. Prideaux, does not, it seems, quarrel with the actual method of my reasoning, but urges that the conditions necessary for the

existence of the premises do not practically obtain. I may remark, however, that Mr. PrIDEAUX does not show how or in what manner my arguments are inapplicable, but contents himself with pointing out what he imagines to be an error in my conception of the mechanism of the part in question. Now, I candidly confess that my knowledge of the state of things at the base of the aorta was not based upon practical observation, but at the same time I must, in justice to myself, say that in the mental review which I took of the possibilities of construction of the valves, I recognised the probable existence of the case which forms the subject of Mr. PrIDEAUX's demonstration. But as he seems to think that if this error be granted the whole reasoning which follows is consequently invalid, I assert that it is by no means obviously certain, *a priori*, that an alteration in the conditions of its application must necessarily modify the conclusion. On the contrary, this very point which he deems it needless to prove because he has no doubt that it will be allowed, is the very point on which the whole question turns. I think also that in the further illustration of this I shall be able to show that Mr. PrIDEAUX has missed the sole idea for which I was anxious to contend, viz., "that no mechanical advantage is gained by the expansion of the aorta towards its termination." Moreover, if I can point out the occasion of his difference from myself, I shall at the same time be rendering my own assurance the more complete.

In the first place, then, I think the difference is more verbal than real, and depends upon a certain ambiguity in the term "force of reflux." This I have interpreted to mean the pressure which would be represented by an area equal to the normal calibre of the vessel, being of opinion that it cannot naturally be applied to the multiplied pressure which would be given by taking the total area of expansion as its equivalent. The former pressure is transmitted without diminution to the unsupported area of the valves.

Again, the statement that "owing to the expansion of the aorta towards its termination, the force of reflux is most efficiently sustained by the muscular substance of the ventricle," is undoubtedly true in one sense; but in this case it is reduced to a mere truism, and amounts simply to this, that "the muscular substance of the ventricle being partially exposed to the contact of the column of blood, the latter rests upon it," and this, indeed, holds good whether the valves be mediate between the blood and the structure of the ventricle or not. However, I cannot help crediting the enunciation of Mr. SAVORY's theory with more than this, and maintain that it naturally induces the idea that the arrangement is in some way advantageous to the valves, *i.e.*, that the pressure is lessened on the unsupported portion.

That this conclusion was contrary to mechanical laws was what I endeavoured to show in my first letter, and that my arguments are equally applicable in the present instance is evident from the fact that the existence of that portion of the valves which rests upon the ventricle is mechanically unimportant and need not be considered, since the remainder of their surface bears just the same pressure as if they were attached directly to the margin of the ventricular ring.

It is possible, however, to make one other supposition on behalf of Mr. SAVORY's theory, that the error lies in its statement, and not in the theory itself. If this be the case it would at any rate be much better expressed thus: "That though the aorta expands towards its termination, the increase of pressure which the valves would thus have to bear is compensated by the support which they receive from the muscular substance of the ventricle."

With regard to the last paragraph of your correspondent's letter, in which he denies the possibility of contraction of the aortic orifice during the diastole, I can only say that instead of imagining this to be the case, I expressed a strong doubt as to its occurrence. For the original statement of the text-book and not myself is responsible, as may be seen from the following quotation: "The reflux of blood is most efficiently sustained by the ventricular wall, which at the moment of its occurrence is probably in a state of contraction." That this, however, should take place is, as Mr. PrIDEAUX justly observes, an impossibility, and only proves the existence of another error either of theory or enunciation.

W. PERCY ASHIE

51, Palace Gardens Terrace

#### Flight of Birds

THE DUKE of Argyll appears to maintain that a bird can remain at rest in a uniform horizontal current by simply

placing and maintaining itself in a certain fixed attitude.\* He seems likewise to think that the muscular effort required to maintain this attitude is somehow an explanation of the phenomenon.

But would a dead bird, of precisely the same weight, size, shape, &c., rigidly fixed in the same attitude, also remain poised under like conditions? Of course I do not refer to the practical difficulty of maintaining an exact balance in the case of a dead bird, but in order to test the theory I suppose a mathematically uniform current and a mathematically perfect poise.

The live bird being perfectly motionless, the two would be precisely in the same mechanical condition, although the rigid attitude of the live bird would be maintained by dint of muscular exertion, and that of the dead bird by *rigor mortis*. Under these circumstances, would the dead bird fall to the ground or remain poised? If the former, what mechanical forces would apply to it which do not apply to the live bird? If the latter, then it would clearly follow that both birds could without change of attitude move with a uniform velocity, in a horizontal line, through still air; for it is clear that the mechanical problem is precisely the same, whether the air be in motion and the bird at rest, or the bird in motion and the air at rest. In each case the relative motion is the same.

Suppose, for example, a bird were poised at rest in a westerly breeze, moving over the earth's surface at the rate of twelve miles an hour, and suppose also the surface of the earth on account of latitude to be moving at an equal rate in the opposite direction. To anyone stationed on the surface of the earth this would be a case of the bird remaining still in a moving current. Yet, in fact, the bird would really be moving through still air at the same rate as the surface of the earth. This, I think, will be sufficient to illustrate the fact that the motionless poising of a bird in a uniform current is identical with its uniform motion through still air without change of attitude.

I need hardly point out that the muscular effort necessary to maintain the required attitude, producing no actual motion, can do no mechanical work. It cannot overcome atmospheric friction, nor the effect of the attraction of the earth.

Perhaps, indeed, the following simple way of viewing the subject may render it still more obvious:—

1. If the bird were deprived of its motor weight, *i.e.* if it were exactly of the weight of the atmosphere, then, whatever might be its motionless attitude, it would clearly float away like a balloon with the atmospheric current in which it was immersed.

2. If the air were at rest, then also under the same circumstances it must necessarily fall towards the ground, either vertically or obliquely, owing to its weight.

3. Therefore, by the most elementary law of the composition of motions, it follows that, taking into account the weight of the bird and the motion of the atmosphere, the actual resultant motion will be a motion combined of a motion vertically downwards and one or more horizontal motions.

4. The resistance of the air on the relatively still wings of the bird enables it to convert its downward motion partially into a forward motion also; but it is quite obvious that a motion combined of horizontal motions and a downward motion must result in a downward motion, and cannot produce equilibrium.

The Duke of Argyll's testimony to the fact that birds hover apparently without motion in horizontal air currents is valuable, and no doubt increases the difficulty of accounting for the phenomenon on the hypothesis of upward currents.

Graaf Reinet College

F. GUTHRIE

#### To Microscopists and Entomologists

CAN ANY of your readers who are microscopists and entomologists help me to a successful method of killing and mounting *Hoplophora decumana*—belonging to the order Acarina?

The difficulties it presents are, that on being touched it contracts its head and legs and withdraws them into the horny envelope which surrounds its body, and that portion of the envelope extending over the head then closes tightly upon the aperture, completely shutting in the head and legs, so that in this condition the creature appears like a very minute seed covered with a few spinous projections. I can find no certain method of causing it to die uncloned, or so to mount it as to exhibit its form; and as the creature is not easily met with, I shall feel much indebted by any suggestions. I may add that I have consulted experienced mounters without success.

Hill Top, Midhurst, Feb. 22

R. C. FISHER

\* See NATURE, vol. x. p. 262.



"Chameleon Barometer"

In my first communication (vol. xi. p. 307) upon this subject, I stated that the actual temperature had apparently no effect upon the colour of the paper. Since then I have had reason to change my opinion. During the late severe weather I have had better opportunities of studying the behaviour during frost, and I have observed that though in summer the paper will remain red for a difference of 3° between the thermometers, in very cold weather it is only red when that difference falls to 0°, or perhaps 5°. This seems to agree with the fact that cold air cannot dissolve so much aqueous vapour as warm air. A. PERCY SMITH  
Rugby, March 6

OUR ASTRONOMICAL COLUMN

TOTAL SOLAR ECLIPSE of 878, OCTOBER 29.—In a communication to the *Times* in August 1872, this eclipse, in the days of King Alfred, was pointed out by the Rev. S. J. Johnson, of Upton Helions, Devon, as having been probably total in London. In the Saxon Chronicle it is merely stated that "the sun was eclipsed one hour of the day," without reference to any phenomena of totality; the *Chronicon Sctorum* records "a dark noon;" in the *Annales Fuldenses* we read: "Sol quoque in 4 Kal. Novembris post horam nonam ita obscuratus est per dimidium horam, ut stelle in celo apparent et omninoctem sibi imminere putarent." This night-like appearance of nature clearly indicates that the eclipse was total at Fulda (Hesse-Cassel), and if our calculations assign elements for the eclipse, which show totality at this spot, it may fairly be assumed that they will give very nearly the true phase for London. Correcting the arguments of Damoiseau's Lunar Tables of 1824, so as to bring them into agreement with Hansen for moon and Le Verrier for sun, and taking the minor equations from the Tables, we find the following elements for 878, Oct. 29:—

Conjunction in R.A., oh. 51m. 24s. M. T. at Greenwich.

R.A.	... ..	218	6	10
Moon's hourly motion in R.A.	... ..	37	25	
Sun's	"	2	29	
Moon's Declination	... ..	14	6	44 S.
Sun's	"	15	4	40 S.
Moon's hourly motion in Decl.	... ..	8	25	S.
Sun's	"	...	...	0 48 S.
Moon's horizontal parallax	... ..	60	35	
Sun's	"	...	...	0 9
Moon's true semi-diameter	... ..	16	31	
Sun's	"	...	...	16 12

Assuming the position of Fulda to be in longitude oh. 38m. 41s. E., and latitude 50° 33' 7", we find by direct calculation from the above elements a total eclipse, totality commencing at 2h. 9m. 32s. local mean time, and continuing 1m. 41s. with the sun at an altitude of 19°. The partial phase began at oh. 56m. and ended at 3h. 24m. The Fulda annalist has "post horam nonam" for the time of the eclipse, but the times we have found cannot be very much in error. The sun rose at Fulda on this day at 7h. 12m. apparent time, or at 6h. 57m. mean time, so that the ninth hour from sunrise would be 4 P.M. To reconcile this difference, Dr. Hartwig, of Leipsic (who calculated the eclipse in 1853 from the best data then available, without finding it quite total at Fulda), conjectured that the author of the Chronicle might have reckoned his time from the commencement of twilight at the beginning of the month. However this may be, our elements, which may be expected to be pretty near the truth, have indicated a very measurable duration of totality at Fulda. Calculating now for London (St. Paul's), we again find a total eclipse commencing at 1h. 16m. 20s. mean time, and ending at 1h. 18m. 10s., or with a duration of 1m. 50s. If any reader should have the curiosity to examine the track of totality further, the following formulæ will assist

him. Putting  $l$  for the geocentric latitude of place, and  $L$  for its longitude from Greenwich, reckoned positive eastward,  $t$  for Greenwich mean time—

$$\begin{aligned} \cos. w &= 136^{\circ}55'50'' - [2^{\circ}137'60'' \sin. l + 1^{\circ}70924 \cos. l \cos. (L + 155^{\circ}31'7'')] \\ t = 1h. 17m. 15s. & \mp [1^{\circ}70681 \sin. w - [3^{\circ}3243 \sin. l \\ & - [391281 \cos. l \cos. (L + 105^{\circ}10'4'') \end{aligned}$$

Upper sign for beginning of totality, lower one for ending; the quantities within the brackets are logarithms.

The Rev. S. J. Johnson found no other total eclipse in London during the long interval from 878 to 1715, and we are able to confirm his inference that there is not likely to be another one visible in the metropolis for five hundred years from the present time. Less than seven years after the eclipse of 878, or on June 16, 885, a very great eclipse passed over Scotland and Ireland. By a similar accurate computation to that detailed above, it is found, to have been total not far from Nairn, and the duration of totality was little less than five minutes, a most unusual length for so high a latitude. In *Chronicon Sctorum* we read, "The stars were seen in heavens."

ENCKE'S COMET.—The ephemeris of this comet for the present appearance, communicated by Dr. von Asten, of Pulkova, to the St. Petersburg Academy, not having been yet transferred to the *Astronomische Nachrichten*, where such matters are commonly looked for, we continue our reduction of the places to 8 P.M. Greenwich time for the period when the comet is likely to be most easily found in these latitudes:—

	R.A.	N. P. D.	DISTANCE from Earth.
	h. m. s.	° ' 0"	
March 20	1 19 27	75 0 0	1'433
" 22	1 25 58	74 32 8	
" 24	1 32 43	74 6 7	1'350
" 26	1 39 41	73 42 3	
" 28	1 46 50	73 20 4	1'258
" 30	1 54 8	73 2 1	
April 1	2 1 28	72 48 8	1'156
" 3	2 8 42	72 42 4	
" 5	2 15 37	72 45 3	1'042
" 7	2 21 53	73 0 5	
" 9	2 27 19	73 31 9	0 918

The distance from the earth is expressed, as usual, in parts of the earth's mean distance from the sun.

VARIABLE STARS.—Next week we shall give the times of maxima and minima of the better known variable stars for two or three months in advance, calculated from the elements in Prof. Schönfeld's last catalogue. It does not appear that an ephemeris for 1875 has been circulated as in several previous years.

THE FRENCH TRANSIT EXPEDITION TO NEW CALEDONIA

WE have received the following interesting communication from a correspondent:—

The French Transit of Venus Expedition to New Caledonia was the result of an after-thought on the part of the French Academy, which only took a definite form in the shape of active preparations for the great event in May last, months, if not years, after the other stations had been fixed on and the construction of the necessary instruments commenced. The New Caledonian observers were consequently at a great disadvantage, being obliged to complete all their arrangements within the short space of ten weeks, and to start for this *Ultima Thule* of civilisation in the middle of July. Everything, however, was got in readiness at home with so much care and despatch that nothing of the slightest importance, either in the astronomical or photographic department of the expedition, has been found wanting. The observatory has been fitted up and the observations made with as much completeness as if the centre of France, and not a convict settlement at the very opposite extremity of the

world, had been the scene of operations, and the results, though not all that could be desired, are nevertheless well worthy of the time and money expended in obtaining them.

M. André, of the Paris Observatory, a well-known French astronomer, was appointed director of the expedition, whilst to M. Angot, Professor of Physics in the Normal School, Paris, the photographic portion of the work was entrusted. The instruments to be used consisted of five telescopes of various powers; a very complete photographic apparatus which will be described hereafter; a meridian instrument; an apparatus for producing an artificial transit, with electric chronograph carrying four pens attached; and lastly, two instruments for accurately determining the magnetic inclination and declination of Nouméa, which up to the present time have never been exactly known. The largest of the telescopes (7.5 in.), as well as three others (5 in.), was provided with an objective silvered by M. Foucault's process, the fifth having an unsilvered lens of 3.5 in. diameter, and of extremely good definition. All the instruments were equatorially mounted, three of them being connected with the chronograph, whilst the other two obtained their time by means of clock and chronometer. The telescope used for the photographic part of the work had an objective of 5 in. diameter and 13 ft. focal length, and was firmly fixed in a horizontal position on stone pillars, the image of the sun being directed along the axis by a large silvered mirror placed outside and moved at will from the interior by means of long wooden rods on either side of and parallel to the telescope. During the transit an assistant stood near this mirror, and at every command "*Décomptes*," removed the cover (placed on the mirror to prevent it becoming heated, and thereby causing distortion of the sun's image), and replaced it immediately after the plate had been exposed. With this apparatus, the daguerreotype process of sensitising a silvered plate of copper by means of iodine and bromine, developing in a mercury bath and fixing with hyposulphite of soda, was alone employed, and with the greatest success.

Though the day was somewhat cloudy, considerably over 100 very well-defined pictures of Venus during the Transit were obtained, together with 130 others, rendered less distinct by the intervention of clouds. When it is known that for several days previous to the 9th, the weather had been so bad that all hopes even of a glimpse of the transit of the planet were abandoned, and that dense clouds hung over the whole sky, and heavy showers of rain fell up to within four hours of the first contact, M. Angot may well be congratulated on the success of his labours. These daguerreotype pictures are not quite 1.5 in. in diameter, and were obtained by exposures of the plates varying from  $\frac{1}{150}$  to  $\frac{1}{30}$  of a second in duration. M. Janssen's method was not employed, but a very simple plan was adopted of placing the sensitised plate in a frame fixed at the focus of the chemical rays, and causing the exposure by sliding in front of it a metallic screen with a slit in it, whose width of course varied with the time necessary for exposure. A clock connected electrically with the sidereal one in the main observatory was placed in a convenient position above the telescope, and the instant of each exposure accurately noted. The assistants in this work, four in number, were all convicts, who performed their share with the neatness and readiness for which Frenchmen, whatever their position in life may be, are so remarkable; and, indeed, nothing has struck me more during the progress of the work here than the aptitude which seems innate in the French race for work of this kind; and it is no disparagement to English soldiers to say that it would have taken them days to learn to read chronometers with the accuracy which their French brethren-in-arms acquired in a few hours and apparently without the slightest difficulty. The main features in all the telescopic observations are the

3.5 minutes' difference between the estimated and observed times of first contact, the absence of the drop, and, in the case of the instruments furnished with silvered objectives, the clear tangential contact of the planet and the sun's limb, which enabled four out of the five observers to obtain the instant of second contact with very great accuracy. With these objectives, which appear to be especially well adapted for observations of this nature, the planet was seen to pass clear and distinct on to the sun's disc, without any appearance of distortion or cloudiness whatever; but with the unsilvered objective an appearance was observed as if a drop, such as those described by English astronomers, was about to form. Without forming, however, it changed almost imperceptibly into a tremulous haziness, which rendered it impossible to say when the actual contact took place, and compelled the observer to note two instants, one when this haziness first appeared, and the other when it had so far disappeared in the increasing brightness in the rear of the planet that he was confident that Venus was fairly on the solar disc. These two instants are separated by an interval of thirty-four seconds, and their mean corresponds within two or three seconds with the instant of tangential contact observed with the other instruments. Whether the slight cloudiness of the sky, or a constant error peculiar to all unsilvered objectives, or the fact that the latter telescope was focussed on a spot much nearer to the sun's limb than the other instruments, is to be put down as the cause of this difference or not, seems at present a matter of doubt only to be cleared up when other observations with unsilvered lenses are recorded.

The third and most important contact in New Caledonia was not observed, owing to a cloud which, much to our chagrin, strayed over the sun's face some 6' before the estimated time of egress, and completely shut out our view for about 20', after which the fourth contact was observed, but with a considerable degree of uncertainty, on account of the undulatory appearance of the sun's limb.

I may mention, in conclusion, that the times of duration of the whole transit, *i.e.* the interval between the first and fourth contacts, obtained by three of the observers, differed by only 8", but these were considerably at variance with the estimated duration of the transit as given in the *Nautical Almanac*. Besides MM. André and Angot, three French officers, Capt. Derbès, Bertin, Ribout, and Mr. Abbay, took part in the observations. A.

On board the *Kangaira*,  
Jan. 5, 1875

#### SCIENTIFIC REPORT OF THE AUSTRO-HUNGARIAN NORTH POLAR EXPEDITION OF 1872-74\*

THE real object of the expedition was not particularly that of reaching high latitudes, but rather the investigation of the large unknown sea north of Siberia; the explorers thought they might eventually reach Behring's Straits, without cherishing very sanguine hopes on this point. When during 1871 Lieut. Weyprecht made a preliminary expedition into those regions, he found the whole large sea between East Spitzbergen and Nowaja Semlja so completely unknown, that in spite of his stopping six weeks at Tromsø, and making inquiries of all Finnmark skippers and whalers, he could not learn anything definite as to the conditions of climate and ice in those parts; few vessels had succeeded in reaching the 76th degree of north latitude. During the two Austrian expeditions this unknown sea has been investigated from 40° to 70° East long. (from Greenwich), and beyond the 79th degree of latitude on the west side and the 80th on the east side; an extensive, hitherto unknown tract of land has been discovered, and Lieut. Julius Payer has made sledge journeys into this land, reaching very nearly 83° N. lat.

In 1871 the explorers had found the sea completely free from

\* Die 2. Oesterr.-Ungarische Nord Polar Expedition unter Weyprecht und Payer, 1872-74. (Petermann's Geogr. Mittheilungen, 1875; heft II.)

ice as far as 78° N. lat., north of Nowaja Semlja, and their intention at the second expedition was to investigate this sea in an easterly direction, taking the Siberian coast as basis, and depending on the influence of the great Siberian rivers, whose great quantities of comparatively warm water probably free the coast from ice almost every summer.

Unfortunately the year 1872 was one of the most unfavourable ever seen. Already in 74° 5' N. lat. the explorers found ice; they could only reach Cape Nassau with great difficulty, and were finally blocked up by packed ice in a locality where, in the previous and following years, there was no ice for one hundred German miles round. They never got within the reach of the Siberian rivers, and the uncertainty with regard to their influence upon the ice along the Siberian coast is still the same as ever. But one point is clearly proved, namely, that the conditions of ice between Spitzbergen and Nowaja Semlja are highly variable from year to year; this circumstance, more than any other, speaks against the advisability of future expeditions to be made on the basis of Franz-Joseph's Land. In 1874 the explorers found the ice again in the same position as in 1871; there is perhaps a certain periodicity in this.

Lieut. Weyprecht formerly thought that marine currents were the principal cause of the general motion of the ice in Arctic regions; he is now of a different opinion, as he maintains that during the drift of their vessel, which was frozen in, in packed ice, and drifted in this state for over fourteen months, the influence of currents was imperceptible compared to that of winds upon the drifting ice. The existence of Gulf-stream water in the great area between Norway, Spitzbergen, and Nowaja Semlja is undeniable; the current cannot, however, be traced directly by its course, but rather by the unproportionally high sea-temperatures in those high latitudes. As a natural consequence of this, the Gulf-stream does not regulate the limits of ice, but the ice, set in motion by winds, regulates the limits of the warmer Gulf-stream water, depriving the same of the last degrees of heat which it contains. A comparison of the *Hansa* drift with the winds would show whether on the east coast of Greenland the drift of ice is only produced by the latter; Sir L. M'Clintock proves with figures that this decidedly is the case in Baffin's Bay. The speed of the drift of course depends upon the force of the winds, local conditions, vicinity of coasts, and the more or less open water. The great influence of the wind upon the ice-fields is explained by their ruggedness; each projecting block represents a sail.

In the vicinity of coasts it is somewhat different; immense currents are often perceived there, originating through the tides, or perhaps through the motion of the ice itself and the winds.

There is a decided general tendency in the ice to move southward during the summer; the reason of this may be the flowing off of melted water in all directions, which causes a breaking-up of the whole Arctic mass of ice. But all other influences upon the motion of the ice are nearly imperceptible when compared to that of winds, and can only be traced in their most general effects. It is quite certain, however, that in the south of Franz-Joseph's Land there is a constant flow of ice from east to west, *i.e.* from the Siberian sea. If the field of ice which held Lieut. Weyprecht's ship a prisoner had not attached itself to Wilczek Island, it would have drifted towards the northern end of Spitzbergen; he arrives at this conclusion from observing the winds of last winter.

To the influence of winds Lieut. Weyprecht also ascribes the existence of open water near all west coasts in those regions; he found the main direction of winter-storms in Franz-Joseph's Land to be E.N.E.; the ice under west coasts is therefore constantly broken up. Lieut. Payer, on the northernmost point he reached, was stopped from extending his sledge journeys further by open water near a west coast, upon which he was travelling.

Also, with regard to quality, the ice in those seas is very variable. While in the summer of 1873 the explorers could not see the end of the field in which their ship was frozen in, they never met fields of such an extent during their retreat; also, with regard to thickness, there was great variety. In 1873 their field formed an irregular frozen mass, with high ice walls in all directions and immense protuberances; in 1874 they found much greater evenness, and although thawing had begun so late that they almost perished with thirst during a month and a half, the ice was so thin in some places at the end of July that they often broke through while drawing their sledges. During the drift the whole mass was doubtless packed very closely; the field, in spite of the constant drifting motion, did not turn round, the bow of the ship pointing always in the same direction; only in September, when the field was greatly reduced, it began to turn; in October

and November large holes were seen in it in the vicinity of the coast, towards the south.

Whether Franz-Joseph's Land can again be reached by ship, Lieut. Weyprecht thinks mainly dependent on favourable conditions of weather and ice; in any case a very warm summer will be necessary, and then it could be done only late in the year. As the most favourable point to start from in such an expedition, he indicates 45° East long., as here he found the barrier of ice in 1871 to be fifty German miles more to the north than in 60° E. long.

In the preliminary expedition of 1871, Lieut. Weyprecht found sure signs of the vicinity of land in 43° E. long. and 78° 75' N. lat., and accordingly he proposed this unknown land as the basis for future expeditions sent to reach the pole. The mysterious Gillis-Land is situated upon 30° E. long. The south coast of Franz-Joseph's Land was seen by Payer at least as far as 50° E. long. Lieut. Weyprecht now thinks he may be permitted to conclude that these three points are connected. Thus Franz-Joseph's Land would become greatly extended in a western direction. Numerous icebergs floating along the coast seem to confirm this idea, and it is hardly necessary to point out how much the interest in Arctic investigation would be increased by this idea proving a correct one.

During a year and a half the explorers had constant opportunities closely to observe the behaviour and formation of packed ice. The phenomenon is instructive, as it is the same in the whole of the Arctic regions. With the exception of land-ice, which clings to the coasts and never reaches far out into the sea, all ice—icebergs as well as fields—is in constant motion, winter and summer; and this, as has been shown, is through the influence of winds. The motion, however, is a different one almost with every field, and thus a certain pressure results wherever two fields touch; this naturally leads to the breaking up of the fields, and the contraction of the ice during sudden low temperatures plays its part in a similar way. If one considers the great extent of the fields, sometimes of many miles, and their enormous masses, one can easily imagine the colossal forces which are active in these phenomena, and the greatness of their effects. When two fields meet, a combat body to body ensues, often lasting only a few minutes, but sometimes even for days and weeks. The edges are then turned up on both sides, upwards and downwards, an irregular wall of ice consisting of wildly-mixed blocks begins to build itself, the pressure increases more and more, masses of ice eight feet long and broad are lifted 30 to 40 feet high, and then fall to make room for others. At last one of the fields begins to shift itself for some distance underneath the other one; often they separate for a while, only to renew the struggle. But the end of it always is that the intense cold unites all into one solid mass; a single field results from the two, and the next storm or quick change of temperature cracks the new field in some other direction, the pieces renewing the old struggle. This is the origin of the ice-fields, which are quite irregular above and below, sometimes only consisting of blocks that have frozen together, and filling up the whole Arctic region as so-called pack-ice.

During winter, snow-storms fill up all smaller irregularities completely. As soon as the sun begins its action, the crushing of the ice decreases, the wintery ice walls diminish considerably, immense masses of ice and snow are melted, and the resulting sweet water forms large lakes on all the lower even parts of the fields. During the summer, about four feet of ice are thus melted down from above; of course the whole field and everything upon it—the explorer's ship, for instance—is raised so much higher. In the following winter it grows below in the same ratio, and thus the whole of the ice is in an uninterrupted process of renovation, from below upwards; we may conclude that all the old pack-ice is replaced by new in the course of two years.

The spaces of open water which naturally occur during the great crushes are soon again covered by fresh ice in winter; the intense cold keeps repairing the broken field of ice. Lieut. Weyprecht observed that within twenty-four hours, and with a temperature of -30° to 40° R. (37.5 - 50° C.), the new crust becomes about a foot thick. The salt of the sea-water has not time to be displaced entirely, the formation of ice going on too quickly, and a considerable quantity freezes into the upper strata of the ice; this quantity decreases downwards as the ice takes more time to form. Beginning at a certain thickness, the ice is almost free from salt. The upper strata, however, on account of the salt they contain, attract moisture in a great degree, and form a tough, leathery mass which bends under foot without

breaking. This, however, is only the case with new ice, as after a short time the salt crystallises out of the ice, and the surface covers itself with a snowy layer of salt, sometimes reaching two inches of thickness. Even in the most intense cold this layer retains so much moisture that it makes the impression of a thaw; only little by little, evaporation and drizzling snow do their work, and the ice itself becomes brittle.

In this way almost all the salt, which was frozen in, crystallises out, and is washed off and back into the sea by the melted water in the next summer. The melted water at the end of the summer is therefore almost free from salt, and has a specific gravity of 1.005. It is evident that a smooth plane of ice, as is found on sweet water, is a very rare occurrence in Arctic regions.

The finest and most interesting phenomenon, the only change in the long night of winter, is the Aurora Borealis; no pen can describe the magnificence of this phenomenon in its greatest intensity. In February 1874 Lieut. Weyprecht saw an aurora, which ran beyond the zenith from east to west like an immense stream of fire, and constantly showed intense prismatic colours running like flames, and as quick as lightning, from one side of the horizon to the other. At the same time flashes of fire came from the southern horizon and reached to the magnetic pole; it was the most stupendous natural display of fireworks he had ever been able to imagine. With regard to the intensity of the aurora, Lieut. Weyprecht says he can prove by data that it differs, independently of the geographical latitude, in the different parts of the Arctic zone, and that the district he visited was a maximal district; when the sky was clear, traces of aurora could be uninterruptedly observed; in the second winter he even kept an "aurora journal," which, however, gave only few positive results, and was left behind in the ship. The phenomenon is past all description and classification, changing constantly and showing new forms at every moment. Lieut. Weyprecht was never able to describe the origin of an aurora; the phenomenon is there, and it is impossible to say whence it came.

Only in a very general way three forms of aurora can be distinguished: first, quiet, regular arcs, slowly passing from the southern horizon and disappearing in the northern one; then, bands of light of great variety of forms, ever changing place and intensity; and lastly, the so-called corona, i.e. radiations from or towards the magnetic pole. Generally the colour is an intense white with a greenish hue; with greater motions and stronger radiations the prismatic colours are often seen in great intensity.

Lieut. Weyprecht spent much time and trouble on spectral observations of the aurora, but unfortunately his spectroscope was too small and imperfect. He could never see more than the well-known green line; compared with the spectral observations of the Swedish Expedition, which were made with much more perfect instruments, his observations are of no value. One interesting fact with regard to the aurora was, however, ascertained. It was found that upon very intense aurora storms followed almost every time; this is proved by meteorological data, and Lieut. Weyprecht thinks he is justified in the conclusion that the Aurora Borealis is an atmospheric phenomenon and closely connected with meteorological conditions; he arrived at this conviction through observing hundreds of aurora, but says he cannot give any positive or important reason for his conclusion.

(To be continued.)

JOHN EDWARD GRAY, F.R.S.

WE have to record the death, on Sunday morning last, at his residence in the British Museum, of Dr. J. E. Gray, late Keeper of the Zoological portion of the National Collection.

Dr. Gray was born in 1800 at Walsall, in Staffordshire, being the eldest of the three sons of Mr. S. F. Gray, a chemist of that town. He was educated for the medical profession, and very shortly exhibited his biological taste, by writing a work on the then new "natural" arrangement of plants. In 1824 Dr. Gray was appointed an assistant in the Natural History department of the British Museum, where, with the assistance of Dr. Leach, he commenced the study of zoology to such good purpose that in 1840 he succeeded Mr. Children as Keeper of the Zoological Collection of the Museum. At that time biology held but a small place in popular favour, especially in the eyes of those most active in the superintendence

of the extension of the British Museum. Against the opposing influences thus affecting his department, not the least of which was the antagonism of Mr. Panizzi, Dr. Gray, by his indefatigable zeal and courage to face obstacles, nevertheless succeeded in bringing the national collection of osteological and skin specimens, during the thirty-five years of his keepership, to so high a standard of excellence, that no other museum, not even Leyden itself, is equal to it.

Most of the biological societies which now exist include Dr. Gray amongst their founders or earliest members. The Zoological Society owes much to him, the number of papers communicated to it by him being very great. He was the leading spirit of the *Annals and Magazine of Natural History*, and was the author of the *Zoological Miscellany*, *Knowsley Menagerie*, and other works. In his Catalogue of the Mammals in the British Museum, which is far advanced towards completion, is incorporated much of the author's work in that direction, published originally in separate short papers.

The qualities which most distinguished Dr. Gray as a naturalist were his great industry in combination with an acute perception of minute distinctions. His imperfect acquaintance with anatomy in many of its branches much limited his generalising powers, and in some cases distorted his view of the relative importance of character based only on osteological features. To all students of the groups of animals which were touched upon by Dr. Gray—and there are but few that were not—that author's work will be found invaluable, both from the independent light which it throws on the subject, and from the careful review which it gives of the previous investigations of other naturalists.

Dr. Gray was elected a Fellow of the Royal Society in 1832; he resigned the Keepership of the British Museum at Christmas last. He leaves a widow, but no children.

#### NEW ORDER OF EOCENE MAMMALS

AT the last meeting of the Connecticut Assembly, February 17, Prof. O. C. Marsh made a communication on a new order of Eocene Mammals, for which he proposed the name *Tillodontia*. These animals are among the most remarkable yet discovered in American strata, and seem to combine characters of several distinct groups, viz., Carnivores, Ungulates, and Rodents. In *Tillotherium*, Marsh, the type of the order, the skull has the same general form as in the bears, but in its structure resembles that of Ungulates. The molar teeth are of the ungulate type, the canines are small, and in each jaw there is a pair of large scalpriform incisors faced with enamel, and growing from persistent pulps, as in Rodents.

The adult dentition is as follows:—Incisors  $\frac{2}{2}$ ; canines

$\frac{1}{1}$ ; premolars  $\frac{3}{2}$ ; molars  $\frac{3}{3}$ . The articulation of the lower jaw with the skull corresponds to that in Ungulates. The posterior nares open behind the last upper molars. The brain was small, and somewhat convoluted. The skeleton most resembles that of Carnivores, especially the *Ursidae*, but the scaphoid and lunar bones are not united, and there is a third trochanter on the femur. The radius and ulna, and the tibia and fibula are distinct. The feet are plantigrade, and each had five digits, all terminated with long, compressed and pointed, unguis phalanges, somewhat similar to those in the bears. The other genera of this order are less known, but all apparently had the same general characters. There are two distinct families, *Tillotheridae*, in which the large incisors grew from persistent pulps, while the molars have roots; and the *Stylinodontidae*, in which all the teeth are rootless. Some of the animals of this group were as large as a Tapir. With *Hyrax* or the *Toxodontia* the present order appears to have no near affinities.

METEOROLOGICAL OBSERVATIONS IN THE PYRENEES

M. DURUOF, the French aëronaut, has just completed a series of three ascents executed from Pau, for the purpose of studying the state of the atmosphere during the recent cold season. Thrice M. Duruof started with a north wind at the surface of the earth, and thrice he was able to find an upper current blowing from the south. The last time he started at 1.30 P.M., travelled upward until 2.30 P.M., moving southwards, when having reached a higher level he was carried northwards. He landed safely at 4 P.M. in the department of Gers.

He found in his last trip that the wind was veering regularly with increasing altitude, and was steady at certain levels, so that it was possible to go in any direction by keeping the proper altitude for a sufficient length of time. All his changes of direction were traced on an Ordnance Survey map. His readings and observations will be sent to the Academy of Sciences for further discussion.

It was observed during the recent cold period that the barometer was low with a northern wind, which is unusual. The three ascents of Duruof may be regarded as affording an explanation of the fact, if we suppose the southern current to have been general at an altitude of 4,000 to 9,000 feet above the earth.

The superior current on the 4th of March was carrying immense quantities of snow at a temperature of 0° C. The snow rapidly melted in its descent, as the air was mild below. It is probable that this snow was caused by the influence of the Pyrenean range, which is very cold. I observed at Paris an effect which can be ascribed to similar causes, from hilly parts of our geological basin situated in the south. On that very day the sky was covered in the south and blue in the north, where immense plains extend to any distance.

At all events the southern aerial stream which carried the balloon northwards was very thick. M. Duruof was unable to find its upper surface, although he reached the level of 11,000 feet.

Other ascents will be made by the same enterprising aëronaut, whose special attention has been so long devoted to the utilisation of various currents according to altitude.

W. DE FONVIELLE

SCIENCE AT THE NEW PARIS OPERA \*

II.

ALL branches of Physics are represented in the New Opera; Heat, Light, Optics, Electricity, Acoustics play their different parts. So far as acoustic instruments are concerned, we may refer to an organ constructed by M. Cavallé-Coll, and formed of eighteen registers, distributed over two key-boards, and a complete foot-board. This organ is worked by four pedals, vibrating the air contained in 1,032 pipes, of which some are more than five metres in height, and above 30 metre in diameter. But it is the electric light which has most interest for us.

After giving a brief account of the invention and history of the voltaic pile, M. Tissandier proceeds to describe the battery connected with the New Opera, which has been organised by M. Duboscq.

The electric light may be thrown upon the magnificent stage by means of a Bunsen battery of 360 elements, which is established in a room on the ground-floor, the length of which is not less than seven metres. M. Duboscq has here arranged six tables of 2.75 metres long by .75 metre broad, which each support a Bunsen battery of sixty elements (Fig. 5). This battery is placed upon the table which is made of very thick unpolished glass that cannot be injured by the acids. The elements are arranged in four rows of fifteen each. The table is provided under-

\* Continued from p. 357.

neath with a board which supports a large rectangular basin, in which the plates are placed after they have been used. The jars of the battery, filled with nitric acid, are, after being used, placed in a tub containing the acid and closed with a wooden lid.

In order to work a battery of such power under favourable conditions, M. Duboscq has had to make special arrangements for the preparation of the sulphuric acid liquid as well as for the zinc amalgams necessary to put the system of batteries in action.

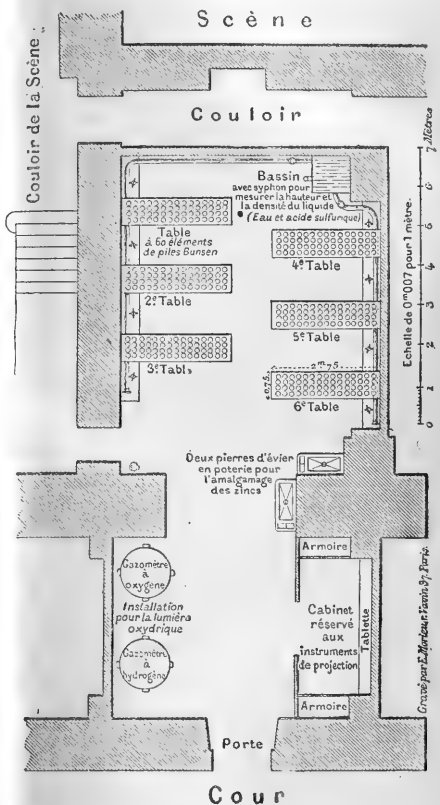

FIG. 5.—Plan of the Electric Room at the New Opera.

At the right corner of the electric room is a large reservoir, of the capacity of about one cubic metre, where water mixed with one-tenth of sulphuric acid can be stored. A spigot permits this liquid to run into a vertical siphon formed of a large tube, into which an areometer is plunged to ascertain its quality, and make sure that the preparation has been made in the proper proportions. The reservoir is furnished at its lower part with an earthenware pipe which is conducted along the walls of the room, opposite the six battery tables. Beside each table an earthenware spigot enables the operators to run the liquid into earthenware jugs, from which they fill the battery jars with the liquid.

By an excellent precaution M. Duboscq has obviated

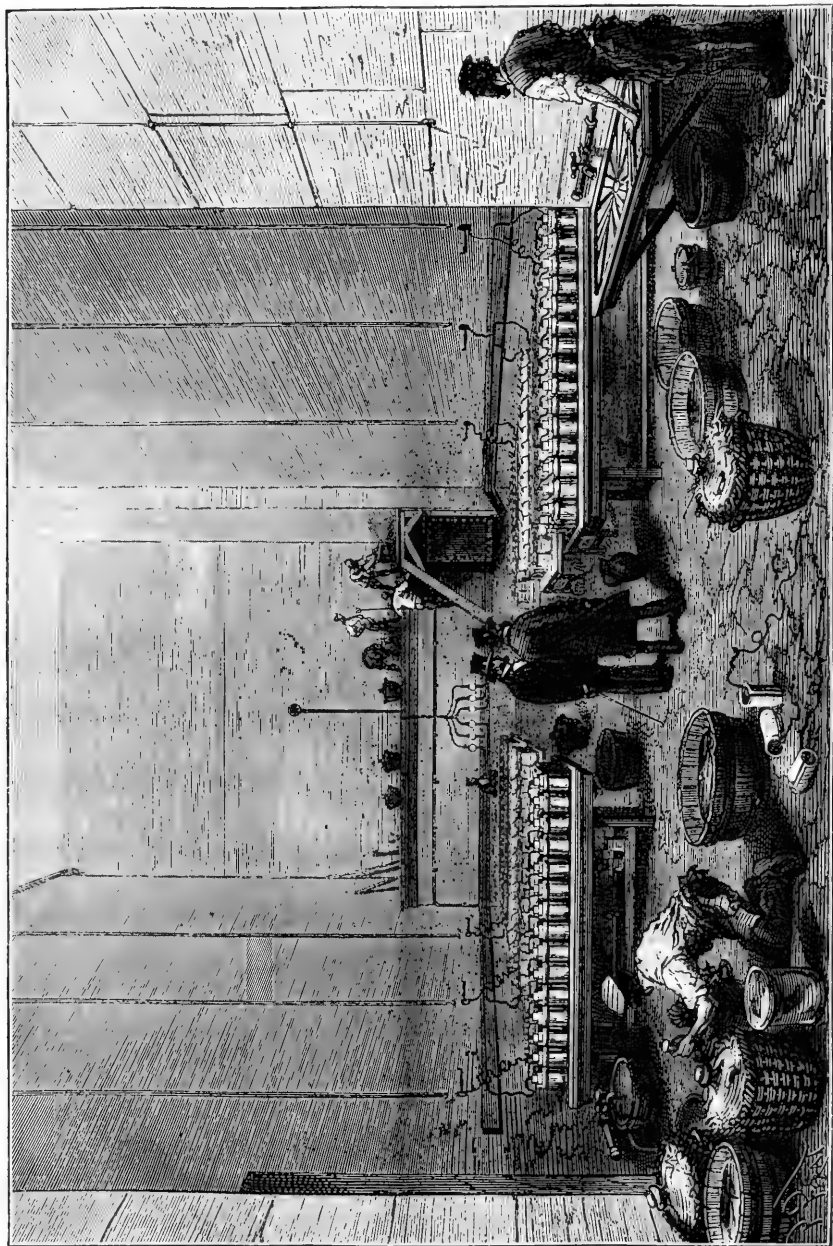

FIG. 6.—View of the Electric Room at the New Opera.

the dangerous action of the nitrous vapours, by placing here and there upon the piles saucers containing ammonia, which condenses them.

Each table, as we have said, forms a battery of sixty elements. The electric wires are conducted along the wall at the bottom of the room, where they traverse six galvanometers (Fig. 6). Each of these galvanometers indicates, by means of the needle with which it is provided, the condition of the battery to which it corresponds. The six isolating wires, after leaving the six galvanometers, pass along the walls to the stage, where the currents which they carry may be utilised either singly or by twos or threes, according to the degree of intensity which it is wished to give to the light. The distance which the current runs from the electric room to the most distant point of the stage is about 122 metres; the total length of all the wires is about 1,200 metres.

M. Dubosq, imitating the systems of telegraphic wires, makes use of the earth as a return current; one of the poles of each battery is in communication with the iron of the building. Without this arrangement it would have been necessary to double the length of the wires.

In most instances M. Dubosq places his electric lamp on one of the wooden galleries which run along the higher regions of the scenery above the stage. It is from this artificial sky that he, a new Phœbus, darts upon the nymphs of the ballet the rays of his electric sun. It is from here, decomposing the light by means of the vapour of water, he throws upon the stage a veritable rainbow, as in *Moses*; again, it is thus that he causes the light from the painted windows to fall upon the flags of the church where Margaret is in the clutches of remorse. Sometimes the electric apparatus is placed on a level with the stage, when it is sought to produce certain special effects, such as that of the fountain of wine in Gounod's opera. The lime-light is also used to produce certain brilliant effects in the New Opera.

It will thus be seen that the electrical arrangements in the New Opera leave little to be desired. There is an electric battery of extraordinary power, which might be profitably used for certain experiments of high interest, requiring an electric power of great intensity. M. Tissandier makes the very happy suggestion that this powerful battery might be utilised for the purpose of scientific research, and we hope that those who have the management of the Opera will take his hint; they ought to remember how much their art owes to the researches of science. He also very appropriately suggests that the Government which has made such a lavish expenditure, forty million francs, on a place of amusement, might also benefit the country even more by doing something to restore to efficiency the buildings in which the work of science is carried on. At all events it will be seen that in this magnificent building Science occupies a place of no mean importance.

### NOTES

LETTERS have been received from the Eclipse Expedition from Suez. They had heard from the Viceroy that arrangements had been made to have a vessel awaiting them at Galle.

THE following telegram has been received by the *Times* from its St. Petersburg correspondent, with regard to the Transit of Venus:—"Herr Struve reports that at Hakodaki both interior contacts were observed. At Wakhoika, on the coast of the Pacific east of Vladivostok, only the first interior contact was observed. At Kamen Riboloff, on Lake Hanka, all four contacts were satisfactorily observed, but no heliometric measurements. At Ashoodeh, on the Caspian Sea, some diameters and chords were measured; but the sun was covered by clouds at the moment of contact. No report yet from Pekin." We would also call

attention to the account of the French observations in New Caledonia, which we publish this week, and to the interesting letter in yesterday's papers from Capt. Fairfax, of the *Volage*, to the Admiralty, giving some details of the Kerguelen Island parties. The astronomers, he says, are pleased with their success. News has now been received more or less from all the Kerguelen parties; we hope to be able to summarise them next week.

PROF. C. S. LYMAN writes to the *New York Tribune* to say that he observed the planet Venus on the 8th of December, a few hours before its transit began, and found that from the time when it was  $1^{\circ} 50'$  distant from the sun's centre, up to the time of its passage across its disc, it was apparently surrounded by a ring of light, which appearance was due to the refraction of the sun's light passing through the planet's atmosphere on its way to the earth. This phenomenon was first observed by Prof. Lyman in 1866, and will again occur in 1882, being repeated, in fact, as often as the planet approaches within the limiting distance above mentioned. When further from the sun than this limit, the circle of light becomes a segment only, whose size diminishes as the planet recedes from the sun.

MR. SLATER, one of the naturalists sent out by the Royal Society with the Transit of Venus Expedition to Rodriguez, is now on his way home. Dr. Balfour, who, after his special work, has devoted a month to the Island of Bourbon, is expected to arrive in England at the end of the present month. The collections made have been embarked, and there is reason to hope that in the course of a few weeks we shall be in possession of a complete report of all that has been accomplished by the three young men appointed to explore the singular island Rodriguez. An instalment of their results has already appeared in the Proceedings of the Royal Society. In like manner, Mr. Gulliver is devoting a month to marine zoology at Zanzibar.

THE list of candidates for the Fellowship of the Royal Society is closed for the present session. The number up is fifty-four.

WE hope that advantage will be taken of the *conversations* of the Royal Society which is to be held on the 7th April, to exhibit the improvements effected in philosophical apparatus during the past year. It has happened more than once that an important improvement has been shown for the first time at the Royal Society, and we shall be glad if the practice can be continued. The rapidity with which instruments become obsolete in these days is perhaps the most remarkable evidence of the advance of science.

THE large and influential deputation from University College which waited upon the Duke of Richmond and Viscount Sandon on Tuesday received what we think may be regarded as on the whole a satisfactory reply. The deputation showed that the means and buildings and apparatus at the command of the College are totally inadequate to the present advanced position of science and to the efficient discharge of the work which the much underpaid professors have to perform. The Duke of Richmond's reply shows, we think, that the Government are really anxious to help the cause of science and of education as far as the means at their command will enable them. He rightly said that the movement which caused the deputation to wait upon him and his colleagues was a legitimate one. "I think," he said, "it would be advantageous to us in considering this question if the Council of the College could see their way to lay before us some estimate of the sum of money that they would seek from the Government, and the mode in which they would propose to spend the money if a sum were granted." This seems to us quite reasonable, and augurs well for the cause of those institutions which can really prove that they deserve to be helped.



As was to be expected, the estimates for the Arctic Expedition were passed by the House of Commons last Friday with complete unanimity. The sum asked for was 98,620*l.* There was appended to the estimate a further sum of 16,000*l.* for the next financial year; and for future years, while the expedition is out, there will be an additional sum of 13,000*l.* In addition to all this, there is a contingent possibility of about 50,000*l.* being required in case of its being thought necessary or desirable to send out a relief ship in consequence of the expedition not having returned as soon as was expected. We do not think it likely that this last item will ever be required, though it is creditable to the House that not a voice was raised against any of the items in the estimate. It has been decided that a man-of-war will accompany the expedition as far as Upernivik, where she will fill the ships up with coals and provisions. It is stated that the *Pandora*, which was one of the vessels named for the expedition, but was condemned on survey, has been purchased from the Admiralty by Mr. Allen Young, a lieutenant in the Royal Naval Reserve, and it is rumoured that he will assume command of her, and accompany the *Alert* and *Discovery* during the summer. Mr. Young served with Admiral Sir Leopold M'Clintock on board the *Fox* in the Franklin Search Expedition.

SOME official papers concerning the Arctic Expedition have just been published by the Admiralty; these contain the arguments which have been urged on behalf of the Smith Sound route, as well as details concerning the fitting of the ships, appointment of officers and men, &c., with which our readers are already familiar. The chosen route offers the only promise of a continuous coast-line stretching far northwards, and upon this fact the prospect of reaching the Pole by travelling parties mainly depends. It is, moreover, the only route, so far as our knowledge extends, where the operations of an expedition can be confined within such limits that succour would be reasonably certain of reaching it. Along with the papers an Admiralty Chart of the Polar Sea is published. Rear-Admiral Sir F. Leopold M'Clintock will supply each of the two ships with a copy of his own manuscript notes on the fitting of sledges and tents, the scale of clothing and provisions, and all the results of his own experience in sledge travelling. The article on the work of the Arctic Expedition, in the last number of the *Geographical Magazine*, is mainly taken from these notes.

WE regret very much that it has been finally decided that no professional geologist shall accompany the Arctic Expedition, the main reason, we believe, being the want of accommodation. The fact is that a botanist is to be sent out who is not wanted, as one of the surgeons is a good botanist; while the place required for a geologist is thus uselessly occupied. The expedition is nothing if not scientific, and surely geology is one of the sciences in which some of the most valuable results would be obtained by an expedition to high polar lands. In this connection we would draw our readers' attention to the first instalment of a paper in this week's *NATURE*, giving some valuable details of the scientific results of the Austro-Hungarian Expedition. If the results of our expedition be as valuable in proportion to its size and equipment, we may expect science to reap a large harvest indeed.

A LETTER from Captain David Gray appears in Hefst iii. of Petermann's *Mittheilungen*, giving reasons for his preference of the East Greenland-Spitzbergen route for Polar exploration over the Smith Sound route. It is accompanied by an illustrative map.

To note the appearance of a new scientific society is one of the chief pleasures in recording the progress of science; and when the incident occurs in the midst of a community given up

to commerce, the pleasurable feeling is enhanced. A Society has been started in Trieste, that busy port at the head of the Adriatic, under the title "Società Adriatica di Scienze naturali," or, as the German-speaking portion of the inhabitants call it, "Naturwissenschaftliche Adriatische Verein." We have received a list of the members, a copy of the statutes, and the first number of the *Bollettino*. This, an octavo of about sixty pages, published in December last, contains an address by Dr. Syrski on the objects of the Society, and on the advantages generally of the study of natural history; a paper, with illustrations, on the "Organi della riproduzione e della fecondazione dei pesci ed in ispezialità delle Anguille;" and one of much interest, "Sulle attuali cognizioni chimiche del mare Adriatico." These papers exemplify the scheme which the Society has formed—investigation of the Adriatic and its coasts, and the promotion of a knowledge of natural history. In carrying out this scheme there are many important questions which may be elucidated, especially in a southern latitude, and we offer to the new Society our best wishes for its success. We hope it will find many correspondents in this country.

THE Ateneo Propagador de las Ciencias Naturales offers a prize of 500 pesetas (about 20 guineas) for the best original memoir on the mineralogy, botany, or zoology of Spain. Any person, whether a member of the society or not, can compete for this prize. Memoirs must be sent in to the secretary of the society before the 30th September, 1875. A printed paper with further particulars may be procured from the secretary, whose address is Calle Ancha de San Bernardo, 15, Madrid.

THE new part of the official Topographical Atlas of Switzerland contains the first part of a new hydrographic map, in four sheets, of the Lake of Geneva, the result of a recent minute examination of the lake by the Government engineer, M. Ph. Gosset. From these sheets a clear and precise idea of the configuration of the lake may be obtained, and M. Gosset's examination confirms generally that of De la Beche made about fifty years ago, the former, however, being infinitely more precise and detailed. The bottom of the lake forms a large valley bordered by two slopes (*talus*). The length of this plain is about six kilometres; its bottom is very flat, and the inequalities never exceed ten metres in a transverse section of the lake. Profiles taken perpendicularly to the axis of the lake are nearly all contained between two curves of ten metres in height. There is nothing in the axis of the lake like a longitudinal valley; on the contrary, there is rather a slight median elevation, and two lateral valleys, not strongly marked, along the foot of the slope. One interesting result of M. Gosset's examination is to confirm the absence, in the depths of the lake, of accidents, inequalities, rocks, glacial moraines, and erratic blocks. Further details of this valuable map may be obtained in an article by Dr. Forel in the January number of the *Archives des Sciences* of the *Bibliothèque Universelle*. The article has also been separately reprinted.

WE regret very much the news that the expedition which started from Burmah into China some time ago (see *NATURE*, vol. xi. pp. 175 and 209), has met with a disaster. On February 22, at a place called Mauwine, it was attacked by several hundred Chinese, together with a large number of the hill tribes. The main body of the expedition escaped with three wounded, but losing it, is feared, either the greater part or the whole of its baggage. Moreover, a distinguished Engineer officer, Mr. Margary, who had made his way overland from Burmah to form the expedition, was separated from it, and with five Chinese servants surrounded and killed.

THE recent polar weather has told heavily upon French men of science. Every week a fresh death is reported, and this week we are apprised of the death of M. Louis Mathieu, at the age

of ninety years. M. Mathieu was elected fifty years ago to fill the place vacated by the death of Mestier. That celebrated comet-seeker of the eighteenth century had been himself a member of the Academy for fifty years. Two persons occupying the same seat for a period of more than a century is an example of acedemical hereditary longevity which is likely very seldom to occur. M. Mathieu was the brother-in-law of Arago, a circumstance which had added much to his personal credit and influence. He was a member of the Bureau des Longitudes, and editor of the *Annuaire* for more than sixty years. He had been employed in the first part of the century in connecting French and English triangulations.

THE supplementary part No. 42 of Petermann's *Mittheilungen*, advance sheets of which have been forwarded us, contains the first half of a translation from the Russian of the celebrated traveller Sewerzow's exploration of the Thian Shan Mountain System in 1867-68. A translation of the same traveller's exploration of the Tschu and Syr Darya region in 1864-65 appeared in the *Journal* of the Royal Geographical Society for 1870, by Mr. R. Mitchell. The present translation is accompanied with a magnificent chromolithographic map of the mountainous region around Lake Issyk-Kul, from Russian official surveys. Sewerzow made a careful study not only of the geography, but of all departments of the natural history, of the meteorology, and general physical characteristics of the region which he explored.

THE Council of the Senate of Cambridge University have had under their consideration the duties and stipend of the Jacksonian Professor. The Council are of opinion that it will be advantageous to the University, as well as in direct conformity with the design of the professorship, that the lectures of the professor should be directed hereafter, at least in part, to the illustration and advancement of the knowledge of some branch or branches of applied physics. They further recommend that the next Jacksonian Professor receive from the University chest such a sum as will with his endowment stipend raise the income of the professorship to 500*l.* per annum; that he shall be required to reside within the precincts of the University for eighteen weeks during term time in every academical year, to give one course of lectures in each of two terms at least, and to give not fewer than forty lectures in every academical year.

THE same body have recommended that a managing council, consisting of the Vice-Chancellor and twelve other members of the Senate, be appointed in connection with lectures and classes at populous centres; and that the Syndics be required to make an annual report to the Senate.

THE Council of the Pathological Society, we learn from the *British Medical Journal*, have arranged that a discussion shall be opened, by Dr. Charlton Bastian, F.R.S., at the meeting of April 6th, on the Germ-theory of Disease, being a discussion of the relation of Bacteria and allied organisms to virulent inflammations and specific contagious fevers. It is expected that Dr. Burdon-Sanderson will take part in the discussion; and it is hoped that, besides the members of the Society interested in this important subject, Prof. Lister of Edinburgh, and it may be Prof. Billoth of Vienna, will find opportunity of being present and taking part in the debate.

AT the last *soiree* of the Paris Observatory, M. Cornu made some exceedingly interesting experiments with his apparatus for measuring the velocity of light. The mirror for reflecting the ray had been placed on the top of a barrack at only 1,280 yards from the Observatory. The wonderful effect of the extinction of the ray by a certain speed of rotation of the wheel was easily observed, as also its reappearance with an increased velocity. The cloudy state of the atmosphere did not prevent the experiment from being a success. It is expected

that the apparatus will be sent to the next meeting of the British Association.

AT a recent meeting of the Senate of the University of London, it was resolved that there is no sufficient reason for perpetuating the slight differences which at present exist between the curricula of the Women's General Examination and the Matriculation Examination; and that in and after the year 1876 the curriculum of the Women's General Examination be the same as the curriculum for the time being of the Matriculation Examination, except that, in the year 1876, women shall have the option of being examined according to the present instead of the altered curriculum.

THE meeting of delegates of the French Sociétés Savantes will take place at the Sorbonne after Easter, as usual, and will have a special interest for meteorologists. M. Leverrier, who will be appointed the President of the Commission of Sciences, has sent a circular to the several presidents of the Meteorological Commissions, asking them to send as many meteorologists as they can to Paris on that occasion; and the intention of the Ministry being to call a special Congress for Meteorology in order to group together the various Departments into natural meteorological districts.

THE destruction of seals in the Arctic seas has been carried on to such an extent that fears are entertained of the annihilation of these animals. The Peterhead sealers and whalers have therefore determined to agree to a "close time," during which it shall be unlawful for any sealing-ship to kill seals, or even to leave port for the fishing-grounds; thus giving the newly-born seals time to develop into a useful size, and enabling even the parent-seals to escape. It is hoped to extend this regulation to other countries engaged in the industry; and the Board of Trade has been in correspondence with various authorities on the subject. The papers in connection with the case have been presented to Parliament, and will shortly be printed, when the decision of the Government will probably be made known.

THOUGH Indian tobacco is not much esteemed in this country, owing to its being badly prepared, some 796,000 acres of land are under tobacco cultivation, distributed as follows:—In the Bombay Presidency over 40,000 acres; in the Punjab, over 90,000; in Oude, 69,574; in the Central Provinces, 55,000; in Behar, 18,500; in Mysore, 20,000; in Burmah, 13,000; while in Bengal there are some 500,000 acres.

WE learn that the export of cinchona bark from the Nilgiri hills, on the part of the Government, during 1872-73, the first regular year of export, amounted to over 20,000 lbs., which realised 4,000*l.* in the London market. It is anticipated that the returns of the exports for the past year, 1873-74, would show a similar quantity, and that the trade in future years will rapidly increase. Bark from private cinchona plantations in the East Indies and Ceylon appears regularly in the London market, fetching from 10*d.* to 4*s.* per lb. "Very good average prices," it is said, "as compared with those obtained by the South American barks."

THE additions to the Zoological Society's Gardens during the past week include a Hog Deer (*Cervus porcinus*) from Kurrachee, presented by Mr. H. Hughes; a White-crowned Mangabey (*Cercopithecus thibops*) from West Africa, presented by Mr. W. Gordon Patchett; an Egyptian Jerboa (*Dipus aegyptius*) from Egypt, presented by Mr. A. Carey, R.N.; an Anubis Baboon (*Cynocephalus anubis*) from W. Africa, presented by Mr. R. B. N. Walker; an Indian Wild Dog (*Canis primitivus*) from India, presented by H. E. the Governor-General of India; three Crested Falcons (*Baca iophotes*), two Indian Cobras (*Naja tripudians*), two Indian Eryx (*Eryx johnii*) from India, purchased.

## ON THE DYNAMICAL EVIDENCE OF THE MOLECULAR CONSTITUTION OF BODIES \*

### II.

LET us now return to the case of a highly rarefied gas in which the pressure is due entirely to the motion of its particles. It is easy to calculate the mean square of the velocity of the particles from the equation of Clausius, since the volume, the pressure, and the mass are all measurable quantities. Supposing the velocity of every particle the same, the velocity of a molecule of oxygen would be 461 metres per second, of nitrogen 492, and of hydrogen 1844, at the temperature  $0^{\circ}$  C.

The explanation of the pressure of a gas on the vessel which contains it by the impact of its particles on the surface of the vessel has been suggested at various times by various writers. The fact, however, that gases are not observed to disseminate themselves through the atmosphere with velocities at all approaching those just mentioned, remained unexplained, till Clausius, by a thorough study of the motions of an immense number of particles, developed the methods and ideas of modern molecular science.

To him we are indebted for the conception of the mean length of the path of a molecule of a gas between its successive encounters with other molecules. As soon as it was seen how each molecule, after describing an exceedingly short path, encounters another, and then describes a new path in a quite different direction, it became evident that the rate of diffusion of gases depends not merely on the velocity of the molecules, but on the distance they travel between each encounter.

I shall have more to say about the special contributions of Clausius to molecular science. The main fact, however, is, that he opened up a new field of mathematical physics by showing how to deal mathematically with moving systems of innumerable molecules.

Clausius, in his earlier investigations at least, did not attempt to determine whether the velocities of all the molecules of the same gas are equal, or whether, if unequal, there is any law according to which they are distributed. He therefore, as a first hypothesis, seems to have assumed that the velocities are equal. But it is easy to see that if encounters take place among a great number of molecules, their velocities, even if originally equal, will become unequal, for, except under conditions which can be only rarely satisfied, two molecules having equal velocities before their encounter will acquire unequal velocities after the encounter. By distributing the molecules into groups according to their velocities, we may substitute for the impossible task of following every individual molecule through all its encounters, that of registering the increase or decrease of the number of molecules in the different groups.

By following this method, which is the only one available either experimentally or mathematically, we pass from the methods of strict dynamics to those of statistics and probability.

When an encounter takes place between two molecules, they are transferred from one pair of groups to another, but by the time that a great many encounters have taken place, the number which enter each group is, on an average, neither more nor less than the number which leave it during the same time. When the system has reached this state, the numbers in each group must be distributed according to some definite law.

As soon as I became acquainted with the investigations of Clausius, I endeavoured to ascertain this law.

The result which I published in 1860 has since been subjected to a more strict investigation by Dr. Ludwig Boltzmann, who has also applied his method to the study of the motion of compound molecules. The mathematical investigation, though, like all parts of the science of probabilities and statistics, it is somewhat difficult, does not appear faulty. On the physical side, however, it leads to consequences, some of which, being manifestly true, seem to indicate that the hypotheses are well chosen, while others seem to be so irreconcilable with known experimental results, that we are compelled to admit that something essential to the complete statement of the physical theory of molecular encounters must have hitherto escaped us.

I must now attempt to give you some account of the present state of these investigations, without, however, entering into their mathematical demonstration.

I must begin by stating the general law of the distribution of velocity among molecules of the same kind.

\* A lecture delivered at the Chemical Society, Feb. 23, by Prof. Clerk-Maxwell, F.R.S. (Continued from p. 359.)

If we take a fixed point in this diagram and draw from this point a line representing in direction and magnitude the velocity of a molecule, and make a dot at the end of the line, the position of the dot will indicate the state of motion of the molecule.

If we do the same for all the other molecules, the diagram will be dotted all over, the dots being more numerous in certain places than in others.

The law of distribution of the dots may be shown to be the same as that which prevails among errors of observation or of adjustment.

The dots in the diagram before you may be taken to represent the velocities of molecules, the different observations of the position of the same star, or the bullet-holes round the bull's-eye of a target, all of which are distributed in the same manner.

The velocities of the molecules have values ranging from zero to infinity, so that in speaking of the average velocity of the molecule; we must define what we mean.

The most useful quantity for purposes of comparison and calculation is called the "velocity of mean square." It is that

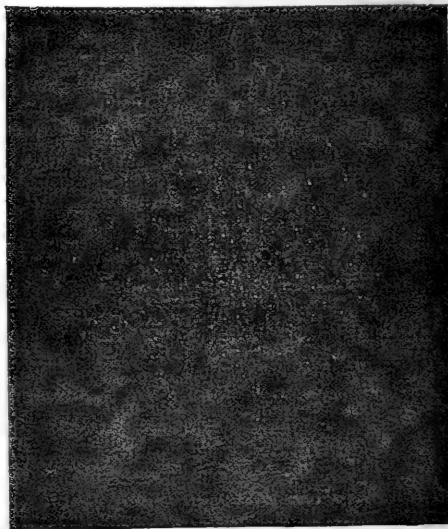

Diagram of Velocities.

velocity whose square is the average of the squares of the velocities of all the molecules.

This is the velocity given above as calculated from the properties of different gases. A molecule moving with the velocity of mean square has a kinetic energy equal to the average kinetic energy of all the molecules in the medium, and if a single mass equal to that of the whole quantity of gas were moving with this velocity, it would have the same kinetic energy as the gas actually has, only it would be in a visible form and directly available for doing work.

If in the same vessel there are different kinds of molecules, some of greater mass than others, it appears from this investigation that their velocities will be so distributed that the average kinetic energy of a molecule will be the same, whether its mass be great or small.

Here we have perhaps the most important application which has yet been made of dynamical methods to chemical science. For, suppose that we have two gases in the same vessel. The ultimate distribution of agitation among the molecules is such that the average kinetic energy of an individual molecule is the same in either gas. This ultimate state is also, as we know, a state of equal temperature. Hence the condition that two gases

shall have the same temperature is that the average kinetic energy of a single molecule shall be the same in the two gases.

Now, we have already shown that the pressure of a gas is two-thirds of the kinetic energy in unit of volume. Hence, if the pressure as well as the temperature be the same in the two gases, the kinetic energy per unit of volume is the same, as well as the kinetic energy per molecule. There must, therefore, be the same number of molecules in unit of volume in the two gases.

This result coincides with the law of equivalent volumes established by Gay Lussac. This law, however, has hitherto rested on purely chemical evidence, the relative masses of the molecules of different substances having been deduced from the proportions in which the substances enter into chemical combination. It is now demonstrated on dynamical principles. The molecule is defined as that small portion of the substance which moves as one lump during the motion of agitation. This is a purely dynamical definition, independent of any experiments on combination.

The density of a gaseous medium, at standard temperature and pressure, is proportional to the mass of one of its molecules as thus defined.

We have thus a safe method of estimating the relative masses of molecules of different substances when in the gaseous state. This method is more to be depended on than those founded on electrolysis or on specific heat, because our knowledge of the conditions of the motion of agitation is more complete than our knowledge of electrolysis, or of the internal motions of the constituents of a molecule.

I must now say something about these internal motions, because the greatest difficulty which the kinetic theory of gases has yet encountered belongs to this part of the subject.

We have hitherto considered only the motion of the centre of mass of the molecule. We have now to consider the motion of the constituents of the molecule relative to the centre of mass.

If we suppose that the constituents of a molecule are atoms, and that each atom is what is called a material point, then each atom may move in three different and independent ways, corresponding to the three dimensions of space, so that the number of variables required to determine the position and configuration of all the atoms of the molecule is three times the number of atoms.

It is not essential, however, to the mathematical investigation to assume that the molecule is made up of atoms. All that is assumed is that the position and configuration of the molecule can be completely expressed by a certain number of variables.

Let us call this number  $n$ .

Of these variables, three are required to determine the position of the centre of mass of the molecule, and the remaining  $n - 3$  to determine its configuration relative to its centre of mass.

To each of the  $n$  variables corresponds a different kind of motion.

The motion of translation of the centre of mass has three components.

The motions of the parts relative to the centre of mass have  $n - 3$  components.

The kinetic energy of the molecule may be regarded as made up of two parts—that of the mass of the molecule supposed to be concentrated at its centre of mass, and that of the motions of the parts relative to the centre of mass. The first part is called the energy of translation, the second that of rotation and vibration. The sum of these is the whole energy of motion of the molecule.

The pressure of the gas depends, as we have seen, on the energy of translation alone. The specific heat depends on the rate at which the whole energy, kinetic and potential, increases as the temperature rises.

Clausius had long ago pointed out that the ratio of the increment of the whole energy to that of the energy of translation may be determined if we know by experiment the ratio of the specific heat at constant pressure to that at constant volume.

He did not, however, attempt to determine *à priori* the ratio of the two parts of the energy, though he suggested, as an extremely probable hypothesis, that the average values of the two parts of the energy in a given substance always adjust themselves to the same ratio. He left the numerical value of this ratio to be determined by experiment.

In 1860 I investigated the ratio of the two parts of the energy on the hypothesis that the molecules are elastic bodies of invariable form. I found, to my great surprise, that whatever be the shape of the molecules, provided they are not perfectly

smooth and spherical, the ratio of the two parts of the energy must be always the same, the two parts being in fact equal.

This result is confirmed by the researches of Boltzmann, who has worked out the general case of a molecule having  $n$  variables.

He finds that while the average energy of translation is the same for molecules of all kinds at the same temperature, the whole energy of motion is to the energy of translation as  $n$  to 3.

For a rigid body  $n = 6$ , which makes the whole energy of motion twice the energy of translation.

But if the molecule is capable of changing its form under the action of impressed forces, it must be capable of storing up potential energy, and if the forces are such as to ensure the stability of the molecule, the average potential energy will increase when the average energy of internal motion increases.

Hence, as the temperature rises, the increments of the energy of translation, the energy of internal motion, and the potential energy are as 3,  $(n - 3)$ , and  $\epsilon$  respectively, where  $\epsilon$  is a positive quantity of unknown value depending on the law of the force which binds together the constituents of the molecule.

When the volume of the substance is maintained constant, the effect of the application of heat is to increase the whole energy. We thus find for the specific heat of a gas at constant volume—

$$\frac{1}{2J} \frac{\rho_0 V_0}{273^2} (n + \epsilon)$$

where  $\rho_0$  and  $V_0$  are the pressure and volume of unit of mass at zero centigrade, or 273° absolute temperature, and  $J$  is the dynamical equivalent of heat. The specific heat at constant pressure is

$$\frac{1}{2J} \frac{\rho_0 V_0}{273^2} (n + 2 + \epsilon)$$

In gases whose molecules have the same degree of complexity the value of  $n$  is the same, and that of  $\epsilon$  may be the same.

If this is the case, the specific heat is inversely as the specific gravity, according to the law of Dulong and Petit, which is, to a certain degree of approximation, verified by experiment.

But if we take the actual values of the specific heat as found by Regnault and compare them with this formula, we find that  $n + \epsilon$  for air and several other gases cannot be more than 4.9. For carbonic acid and steam it is greater. We obtain the same result if we compare the ratio of the calculated specific heats

$$\frac{2 + n + \epsilon}{n + \epsilon}$$

with the ratio as determined by experiment for various gases, namely, 1.408.

And here we are brought face to face with the greatest difficulty which the molecular theory has yet encountered, namely, the interpretation of the equation  $n + \epsilon = 4.9$ .

If we suppose that the molecules are atoms—mere material points, incapable of rotatory energy or internal motion—then  $n$  is 3 and  $\epsilon$  is zero, and the ratio of the specific heats is 1.66, which is too great for any real gas.

But we learn from the spectroscopy that a molecule can execute vibrations of constant period. It cannot therefore be a mere material point, but a system capable of changing its form. Such a system cannot have less than six variables. This would make the greatest value of the ratio of the specific heats 1.33, which is too small for hydrogen, oxygen, nitrogen, carbonic oxide, nitrous oxide, and hydrochloric acid.

But the spectroscopy tells us that some molecules can execute a great many different kinds of vibrations. They must therefore be systems of a very considerable degree of complexity, having far more than six variables. Now, every additional variable introduces an additional amount of capacity for internal motion without affecting the external pressure. Every additional variable, therefore, increases the specific heat, whether reckoned at constant pressure or at constant volume.

So does any capacity which the molecule may have for storing up energy in the potential form. But the calculated specific heat is already too great when we suppose the molecule to consist of two atoms only. Hence every additional degree of complexity which we attribute to the molecule can only increase the difficulty of reconciling the observed with the calculated value of the specific heat.

I have now put before you what I consider to be the greatest difficulty yet encountered by the molecular theory. Boltzmann has suggested that we are to look for the explanation in the mutual action between the molecules and the etherial medium which surrounds them. I am afraid, however, that if we call in

the help of this medium, we shall only increase the calculated specific heat, which is already too great.

The theorem of Boltzmann may be applied not only to determine the distribution of velocity among the molecules, but to determine the distribution of the molecules themselves in a region in which they are acted on by external forces. It tells us that the density of distribution of the molecules at a point where

the potential energy of a molecule is  $\psi$ , is proportional to  $e^{-\frac{\psi}{k\theta}}$  where  $\theta$  is the absolute temperature, and  $k$  is a constant for all gases. It follows from this, that if several gases in the same vessel are subject to an external force like that of gravity, the distribution of each gas is the same as if no other gas were present. This result agrees with the law assumed by Dalton, according to which the atmosphere may be regarded as consisting of two independent atmospheres, one of oxygen, and the other of nitrogen; the density of the oxygen diminishing faster than that of the nitrogen, as we ascend.

This would be the case if the atmosphere were never disturbed, but the effect of winds is to mix up the atmosphere and to render its composition more uniform than it would be if left at rest.

Another consequence of Boltzmann's theorem is, that the temperature tends to become equal throughout a vertical column of gas at rest.

In the case of the atmosphere, the effect of wind is to cause the temperature to vary as that of a mass of air would do if it were carried vertically upwards, expanding and cooling as it ascends.

But besides these results, which I had already obtained by a less elegant method and published in 1866, Boltzmann's theorem seems to open up a path into a region more purely chemical. For if the gas consists of a number of similar systems, each of which may assume different states having different amounts of energy, the theorem tells us that the number in each state is proportional to  $e^{-\frac{\psi}{k\theta}}$  where  $\psi$  is the energy,  $\theta$  the absolute temperature, and  $k$  a constant.

It is easy to see that this result ought to be applied to the theory of the states of combination which occur in a mixture of different substances. But as it is only during the present week that I have made any attempt to do so, I shall not trouble you with my crude calculations.

I have confined my remarks to a very small part of the field of molecular investigation. I have said nothing about the molecular theory of the diffusion of matter, motion, and energy, for though the results, especially in the diffusion of matter and the transpiration of fluids are of great interest to many chemists, and though from them we deduce important molecular data, they belong to a part of our study the data of which, depending on the conditions of the encounter of two molecules, are necessarily very hypothetical. I have thought it better to exhibit the evidence that the parts of fluids are in motion, and to describe the manner in which that motion is distributed among molecules of different masses.

To show that all the molecules of the same substance are equal in mass, we may refer to the methods of dialysis introduced by Graham, by which two gases of different densities may be separated by percolation through a porous plug.

If in a single gas there were molecules of different masses, the same process of dialysis, repeated a sufficient number of times, would furnish us with two portions of the gas, in one of which the average mass of the molecules would be greater than in the other. The density and the combining weight of these two portions would be different. Now, it may be said that no one has carried out this experiment in a sufficiently elaborate manner for every chemical substance. But the processes of nature are continually carrying out experiments of the same kind; and if there were molecules of the same substance nearly alike, but differing slightly in mass, the greater molecules would be selected in preference to form one compound, and the smaller to form another. But hydrogen is of the same density, whether we obtain it from water or from a hydrocarbon, so that neither oxygen nor carbon, can find in hydrogen molecules greater or smaller than the average.

The estimates which have been made of the actual size of molecules are founded on a comparison of the volumes of bodies in the liquid or solid state, with their volumes in the gaseous state. In the study of molecular volumes we meet with many difficulties, but at the same time there are a sufficient number of consistent results to make the study a hopeful one.

The theory of the possible vibrations of a molecule has not yet been studied as it ought, with the help of a continual comparison between the dynamical theory and the evidence of the spectroscopist. An intelligent student, armed with the calculus and the spectroscopist, can hardly fail to discover some important fact about the internal constitution of a molecule.

The observed transparency of gases may seem hardly consistent with the results of molecular investigations.

A model of the molecules of a gas consisting of marbles scattered at distances bearing the proper proportion to their diameters, would allow very little light to penetrate through a hundred feet.

But if we remember the small size of the molecules compared with the length of a wave of light, we may apply certain theoretical investigations of Lord Rayleigh's about the mutual action between waves and small spheres, which show that the transparency of the atmosphere, if affected only by the presence of molecules, would be far greater than we have any reason to believe it to be.

A much more difficult investigation, which has hardly yet been attempted, relates to the electric properties of gases. No one has yet explained why dense gases are such good insulators, and why, when rarefied or heated, they permit the discharge of electricity, whereas a perfect vacuum is the best of all insulators.

It is true that the diffusion of molecules goes on faster in a rarefied gas, because the mean path of a molecule is inversely as the density. But the electrical difference between dense and rare gas appears to be too great to be accounted for in this way.

But while I think it right to point out the hitherto unconquered difficulties of this molecular theory, I must not forget to remind you of the numerous facts which it satisfactorily explains. We have already mentioned the gaseous laws, as they are called, which express the relations between volume, pressure, and temperature, and Gay Lussac's very important law of equivalent volumes. The explanation of these may be regarded as complete. The law of molecular specific heats is less accurately verified by experiment, and its full explanation depends on a more perfect knowledge of the internal structure of a molecule than we as yet possess.

But the most important result of these inquiries is a more distinct conception of thermal phenomena. In the first place, the temperature of the medium is measured by the average kinetic energy of translation of a single molecule of the medium. In two media placed in thermal communication, the temperature as thus measured tends to become equal.

In the next place, we learn how to distinguish that kind of motion which we call heat from other kinds of motion. The peculiarity of the motion called heat is that it is perfectly irregular; that is to say, that the direction and magnitude of the velocity of a molecule at a given time cannot be expressed as depending on the present position of the molecule and the time.

In the visible motion of a body, on the other hand, the velocity of the centre of mass of all the molecules in any visible portion of the body is the observed velocity of that portion, though the molecules may have also an irregular agitation on account of the body being hot.

In the transmission of sound, too, the different portions of the body have a motion which is generally too minute and too rapidly alternating to be directly observed. But in the motion which constitutes the physical phenomenon of sound, the velocity of each portion of the medium at any time can be expressed as depending on the position and the time elapsed; so that the motion of a medium during the passage of a sound-wave is regular, and must be distinguished from that which we call heat.

If, however, the sound-wave, instead of travelling onwards in an orderly manner and leaving the medium behind it at rest, meets with resistances which fritter away its motion into irregular agitations, this irregular molecular motion becomes no longer capable of being propagated swiftly in one direction as sound, but lingers in the medium in the form of heat till it is communicated to colder parts of the medium by the slow process of conduction.

The motion which we call light, though still more minute and rapidly alternating than that of sound, is, like that of sound, perfectly regular, and therefore is not heat. What was formerly called Radiant Heat is a phenomenon physically identical with light.

When the radiation arrives at a certain portion of the medium, it enters it and passes through it, emerging at the other side. As long as the medium is engaged in transmitting the radiation

it is in a certain state of motion, but as soon as the radiation has passed through it, the medium returns to its former state, the motion being entirely transferred to a new portion of the medium.

Now, the motion which we call heat can never of itself pass from one body to another unless the first body is, during the whole process, hotter than the second. The motion of radiation, therefore, which passes entirely out of one portion of the medium and enters another, cannot be properly called heat.

We may apply the molecular theory of gases to test those hypotheses about the luminiferous ether which assume it to consist of atoms or molecules.

Those who have ventured to describe the constitution of the luminiferous ether have sometimes assumed it to consist of atoms or molecules.

The application of the molecular theory to such hypotheses leads to rather startling results.

In the first place, a molecular ether would be neither more nor less than a gas. We may, if we please, assume that its molecules are each of them equal to the thousandth or the millionth part of a molecule of hydrogen, and that they can traverse freely the inter-spaces of all ordinary molecules. But, as we have seen, an equilibrium will establish itself between the agitation of the ordinary molecules and those of the ether. In other words, the ether and the bodies in it will tend to equality of temperature, and the ether will be subject to the ordinary gaseous laws as to pressure and temperature.

Among other properties of a gas, it will have that established by Dulong and Petit, so that the capacity for heat of unit of volume of the ether must be equal to that of unit of volume of any ordinary gas at the same pressure. Its presence, therefore, could not fail to be detected in our experiments on specific heat, and we may therefore assert that the constitution of the ether is not molecular.

J. CLERK-MAXWELL

## SOCIETIES AND ACADEMIES

LONDON

Royal Society, Feb. 18.—“On the number of Figures in the Reciprocal of each Prime Number between 30,000 and 40,000,” by William Shanks. Communicated by the Rev. Dr. Salmon, F.R.S.

“On the Nature and Physiological Action of the *Crotalus*-poison as compared with that of *Naja trifurcata* and other Indian Venomous Snakes,” by T. Lauder Brunton, F.R.S., and J. Fayrer, M.D.

It appears that there is little difference between the physiological effects of the crotaline or viperine, and the colubrine virus. The mode in which death is brought about is essentially the same in all; though there are evidences, even when allowing for individual peculiarities, that the action is marked by some points of difference sufficiently characteristic, to require notice in detail.

We have already expressed our belief that death is caused by the cobra-, *Dabolia*-, and *Hydrophis*-poison, 1st, through its action on the cerebro-spinal nerve-centres, especially on the medulla, inducing paralysis of respiration; or 2nd, in some cases where the poison has entered the circulation in large quantities and has been conveyed more directly to the heart, by arrest, tetanically in systole, of cardiac action, probably owing to some action on the cardiac ganglia; 3rd, by a combination of the two previous causes; 4th, by a septic condition of a secondary nature, and which, being more essentially pathological in its bearings, the details were not considered suitable for discussion here.

There is reason to believe that death is caused in the same way by the *Crotalus*-poison also; and it appears, from the experiments recently performed in Calcutta by Dr. Ewart and the members of the Committee appointed by Government upon *Pseudochis porphyriacus*, or the black snake, and *Hoplocephalus curtus*, or the tiger-snake of Australia, that their virus causes death in the same manner. These reptiles had been sent from Melbourne to Calcutta for the purpose of investigation and comparison. (*Vide* Committee's Report, p. 58 *et seq.*, Appendix.)

But though the actual cause of death is essentially the same, the phenomena which precede and accompany it differ in some degree according to the nature of the poison, the quantity and site of the inoculations, and the [individual peculiarities of the

creature inoculated, as may be seen in the experiments herewith recorded.

The condition of an animal poisoned by the rattlesnake-venom, then, essentially resembles that of one subjected to the influence of the colubrine or viperine poison of Indian snakes:—

Depression, hurried respiration, exhaustion, lethargy, unconsciousness, nausea, retching, and vomiting.

Muscular twitchings, ataxia, paralysis, and convulsions, the latter probably chiefly, though not entirely, due to circulation of imperfectly oxygenated blood, the result of impeded respiration, and, finally, death.

Hæmorrhages or hæmorrhagic extravasations and effusions, both local and general, occur in all varieties of snake-poisoning.

But we observe (and in this our observations are in accord with those of Weir Mitchell) that there is a greater tendency to both local and general hæmorrhage and extravasation of blood and of the colouring matter of the blood, especially as observed in the peritoneum, intestines, and mesentery, and also probably to a more direct action on the cord than in poisoning by either cobra or viper.

The viscera and other tissues, after death are found congested and ecchymosed, and in some cases to a great extent, seeming to show that either a preternatural fluidity of blood or some important change in the vessels, favouring its exudation, has occurred.

Several experiments were made on the physiological action of the virus of the rattle-snake, with the view of comparison with that of the cobra and *Dabolia*.

We are indebted to Dr. Weir Mitchell, of Philadelphia, for a supply of the virus. He was good enough to send about six grains of the dried poison of *Crotalus*—the species not named, but it is believed to be of *Crotalus durissus*.

It has the appearance of fractured fragments of dried gum-arabic and of rather a darker yellow colour, but otherwise resembling the dried cobra-virus sent from Bengal.

There were no very marked differences to be observed in the action of the poison except in the energy with which the cobra exceeded the *Crotalus*.

It appears that the direct inoculation of large doses of the virus, whether viperine or colubrine, into the circulation have the power in some cases of annihilating almost instantaneously the irritability of the cord and medulla, as in others they have of arresting the heart's action.

The local as well as the general effect of the cobra- and *Crotalus*-poisons, *i.e.* colubrine and viperine, is to cause hæmorrhage, ecchymosis, and sanguinolent effusions into the areolar tissue, not only at the seat of inoculation and its neighbourhood, but also in the mucous membranes and other vascular parts. It is obvious also that the *Crotalus*-poison acts more energetically in this respect than the cobra-poison, and that this is perhaps one of the most marked distinctions between them.

Cobra venom is a muscular poison, and the gastrocnemius of a frog immersed in a watery solution of it contracts immediately upon immersion, and loses its irritability very much sooner than one placed in pure water.

In our experiments cobra-poison appeared first to stimulate and then to paralyse the motions of cilia from the mouth of a frog.

It arrests very rapidly the movements of infusoria and of the cilia upon them, but the cilia upon the mantle of a fresh-water muscle continued to move for many hours in an extremely strong solution of dried cobra-venom. In the case of white blood-corpuscles no very distinct action was observed. When applied to a piece of *Vallisneria spiralis* it appeared to have almost no effect, for the motion of the granules within the cells continued with undiminished rigour for two hours afterwards.

Feb. 25.—“On the Forms of Equipotential Curves and Surfaces and Lines of Electric Force,” by W. Grylls Adams, M.A., Professor of Natural Philosophy and Astronomy in King's College, London.

The paper contains an account of certain experimental verifications of the laws of electrical distribution in space and in a conducting sheet, such as a sheet of tinfoil. When two battery poles are attached to any two points of an unlimited plane sheet, or to two points on the edge of a circular disc, or if the disc be bounded by arcs of circles passing through the two battery poles, the lines of force and also the equipotential curves are circles. The equipotential circles have their centres on the straight line joining the battery poles, and the lines of force pass through these poles. In any limited space, whether in the plane or in

the solid, which is bounded entirely by lines of force, no alteration is made in the distribution of the current when that limited space is entirely removed from the conducting space around it.

Several cases are taken in a sheet of tinfoil 18 inches square, with several battery poles about 3 inches apart near the centre of the sheet, and the equipotential curves traced out by means of two poles attached to a delicate galvanometer, these poles being at points of the same potential when the galvanometer needle is at zero; a sheet limited in size by cutting along lines of force is then taken, and in each case it is shown that there is no alteration of the equipotential curves. The forms of these curves are traced out for one positive, and four negative poles at equal distances from it at the corners of a square in the centre of a large sheet of tinfoil; also the curves for one positive and two negative poles at equal distances on either side of it on the same straight line.

When there are four electrodes, two of each kind on an unlimited sheet, an equipotential curve is given by the equation,

$$r^2 = cr_1 r_2'$$

If the four points lie on a circle, and the complete quadrilateral be drawn through them, the circles which have their centres at the intersections of opposite sides of the quadrilateral, and which cut the first circle at right angles, will also cut one another at right angles. One of these circles is shown to be an equipotential curve for the four electrodes, and the other is a line of force.

Hence, if we cut the unlimited sheet along the edge of this latter circle, we shall not alter the forms of the equipotential curves; and within it we shall have one electrode of each kind, the others being their electric images, the product of the distances of an electrode and its image from the centre being equal to the square of the radius of the disc. If an electrode is at the edge of the disc, then the electrode and its image coincides, and the equation to the equipotential curve is

$$r^2 = cr_1 r_2'$$

When one pole is at the edge and the other is at the centre of a circular disc, since the electric image of the centre is at an infinite distance, the equation to the equipotential curve is

$$r^2 = cr_1$$

This is an interesting case, as showing that the equipotential curves do not always cut the edge of the disc at right angles.

On placing one of the galvanometer electrodes at the extremity of the diameter through the battery electrodes, and tracing with the other, it is found that the equipotential curve through that point cuts the edge of the disc at an angle of  $45^\circ$ , and that there are two branches cutting one another at right angles.

These peculiarities are explained on tracing the curve

$$r^2 = 4ar_1$$

corresponding to this case. The extremity of the diameter is a point through which two branches of the curve pass at right angles to one another.

The forms of the equipotential surfaces and lines of force in space may be determined experimentally by taking a large vessel containing a conducting liquid and placing two points, the ends of two covered wires, for battery electrodes at a given depth in the liquid and away from the sides and ends of the vessel, taking similar covered wires immersed to the same depth for galvanometer electrodes.

For two electrodes the equipotential surfaces will be surfaces of revolution around the straight line joining them, and so will cut any plane drawn through this straight line or axis everywhere at right angles.

Hence we may suppose sections of the liquid made along such planes without altering the forms of the equipotential surfaces. This shows that we may place our battery electrodes at the side of a rectangular box containing the liquid, and with the points only just immersed below the surface of the liquid, and the equipotential surfaces will be the same as if the liquid were of unlimited extent in every direction about the electrodes.

We shall obtain the section of the equipotential surface by taking for galvanometer electrodes two points in the surface of the liquid, keeping one fixed and tracing out points of equal potential with the other.

The potential at any point in space, due to two equal and opposite electrodes, is

$$A\left(\frac{1}{r} - \frac{1}{r_1}\right)$$

where  $r$  and  $r_1$  are the distances of the point from the electrodes, so that for an equipotential surface

$$\frac{1}{r} - \frac{1}{r_1} = \text{constant.}$$

These surfaces are cut at right angles by the curves

$$\cos \theta - \cos \phi = c,$$

which are also the magnetic lines of force,  $\theta$  and  $\phi$  being the angles which the distances from the electrodes make with the axis. That the lines of force in a vessel of finite size should agree with the lines of force in space, the form of the boundary of the vessel in a plane through the axis should everywhere be a line of force; but the ends of a rectangular vessel coincide very closely with certain lines of force, either when the electrodes are at the ends, or when there are two electrodes within the vessel, and two supposed electrodes at their electrical images at an equal distance outside the ends of the vessel.

The equipotential surfaces are given in this case by the equation,

$$\frac{1}{r} + \frac{1}{r'} - \frac{1}{r_2} - \frac{1}{r_1} = \text{constant,}$$

and the lines of force by the equation,

$$\cos \theta + \cos \theta_1 - \cos \phi - \cos \phi_1 = c.$$

The curve, for which  $c = 2$  coincides very closely with the ends of the box.

The equipotential surfaces were traced out in sulphate of copper and in sulphate of zinc by the following method:—

A rectangular box was taken, and the battery electrodes attached to pieces of wood which could be clamped at the centre of the end of the box, and could be brought to any required point in the line joining the middle points of the end of the box. The galvanometer-electrodes were attached to T pieces which rest on the ends and side of the box, and the position of the electrodes read off by millimetre-scale placed on the ends and sides of the box.

When the electrodes are parallel lines extending throughout the depth of the liquid the equipotential surfaces are cylindrical, and their sections are given by the equation,

$$\log(r'r' \dots) - (\log r_2 r_1 \dots) = \log c,$$

where there are several positive and several negative electrodes,  $r, r', \dots$  &c. being measured from the points where the electrodes cut the plane of the section.

Hence the forms of these equipotential curves are the same as in a plane sheet, so that the forms traced out in tinfoil will be the same as the corresponding forms in space for line electrodes. These forms may be traced out in sulphate of copper with copper electrodes, or in sulphate of zinc, with amalgamated zinc electrodes.

The results of these investigations show how closely the experimental determination of equipotential surfaces and lines of force agrees with the theory of electrical distribution in space.

Linnean Society, March 4.—Dr. G. J. Allman, president, in the chair.—Messrs. W. W. Scofield and T. Atthey were elected fellows.—Mr. Hanbury exhibited a fungus from South America, a species of *Phallus* allied to *P. impudicus*.—Mr. J. G. Baker exhibited specimens of the two species of plane-tree, *Platanus occidentalis* and *orientalis*, and of the variety of the latter known as *acerifolia*, and pointed out the distinctions between them; also a curious modification of bulb-form in a species of *Drimys*.—Mr. J. R. Jackson read a paper on plants in which ants make their homes; exhibiting specimens of two of the most remarkable of these, *Myrmecodia* and *Hydrophyllum*.—Prof. Thistleton Dyer read a brief note on the structure of the so-called *membrana nuclei* in the seeds of Cycads. Heintzel had described this as a cellular structure, the cells of which had thick walls penetrated by ramifying tubes. There was reason, however, for believing that the membrane only represented the wall of a single cell, and was in fact probably the greatly enlarged primary embryo-sac. What Heintzel had taken for tubes seemed really to be solid. They were arranged all over the membrane after the fashion of what carpet-manufacturers call a "moss-pattern." They were possibly the debris of the thickened walls of the cells of the nucleus which had been destroyed by the enlargement of the primary embryo-sac.—Prof. Dickson exhibited and described a series of microscopic slides illustrating the mode of growth of *Trapolum speciosum*.—A paper was taken as read by Mr. Bentham, on the classification of the natural orders Campanulacæ and Oleacæ.

Geological Society, Feb. 24.—Mr. John Evans, V.P.R.S., president, in the chair.—Before proceeding to the business of the meeting the President spoke of the death of Sir C. Lyell.



"By every one of us," he said, "he was regarded as the leader of our science, by most of us as our trusted master, and by many of us as our faithful friend. He has lived to see the truth of those principles for which he so long and earnestly contended accepted by nearly all whose opinions he valued; and in future times, wherever the name of Lyell is known, it will be as that of the greatest, most philosophical, and most enlightened of British, if not indeed of European geologists."—The following communications were read:—On the Murchisonite beds of the estuary of the Ex, and an attempt to classify the beds of the Trias thereby, by Mr. G. Wareing Ormerod. This paper may be regarded as a continuation of one read by Mr. Ormerod before this Society in 1868. After noticing the mineralogical character of the Murchisonite, Mr. Ormerod described, first, the Red Sandstone beds by the sea-shore. To the east of Exmouth he considered that they were "Keuper," which extended inland to a fault running to the south of Lymptone. A conglomerate rock at the Beacon at Exmouth was probably the upper bed of the "Bunter," and this he considered to be the same rock that occurred at Cockwood on the right bank of the Ex. This overlay soft red rock, containing occasionally fragments of various rocks, and in the upper part a slight trace of Murchisonite. At Dawlish a soft conglomerate containing Murchisonite in great abundance occurred; this extended inland about two miles. On the westerly side of Dawlish conglomerate beds cropped out, containing fragments of granitic and porphyritic rocks, quartz, Lydian-stone; and here the limestone fragments containing animal remains first occurred. After passing the Parson-and-Clerk Tunnel, these conglomerate beds ceased until reaching Teignmouth, and the cliffs consist of soft beds. At Teignmouth the conglomerates, with limestone, again commenced, and continued to near St. Mary Church, in this part alternating with soft sandy or clayey beds. To the north of the fault at Lymptone the Keuper did not appear by the Ex, and the conglomerate with limestone had not been noticed, being possibly buried under the Greensand of Haldon. The beds north of this point on both sides of the Ex were the soft Red Sandstone, with a trace of Murchisonite, and the underlying Murchisonite conglomerates, and near Haldon House beds that it was considered were possibly those to the west of Dawlish occurred. These beds were broken up by various faults running in both north and south and east and west directions. In the district under consideration it was shown that the soft sandy beds, with a trace of Murchisonite, and the underlying bed of Murchisonite conglomerate, occurred in various places, and in such a manner that there could not be any doubt of their identity; these the author considered as marking a clear division in the Red Sandstone. The paper was illustrated by a map and three sections, and photographs of the cliffs, and by numerous specimens.—On some newly exposed sections of the "Woolwich and Reading beds" near Reading, Derks, by Prof. T. Rupert Jones, F.R.S., and Mr. C. Cooper King. The authors described the section of the lowest Tertiary beds lately exposed at Coley Hill, Reading, Derks, comparing it with other sections in the neighbourhood described by Buckland, Rolfe, Prestwich, and Whitaker. At one point in the section oyster-shells are wanting in the bottom bed, as observed also by Whitaker at Castle Kiln. At the same part of the section the leaf-bearing blue clays are also absent, but are continued by irregular thin seams of derived clay and clay-galls, with broken lignite, occasional grey flints, and by at least one green-coated flint and pebble of lydite. At another point, where the blue clay still exists, very numerous and large lumps of clays, rolled and often enclosing sub-angular flints, lie in the sand over the leaf-bed. Some of these clay-galls have passed into concentric nodules of ochre and limonite. The probable derivation of the two sets of clay-galls is from pre-existing clay beds—probably the blue shale, one from its worn end, and the other (upper one) from a terrace or ledge in its thickness—by the action of varying currents in an estuary at different levels. The clay-galls of the upper series vary much in character; some are of dense dark brown and light coloured clays, others of sandy blue and grey clays, many have involved sand and flints from an old shoal or beach. A probably analogous band of flints has been noticed at Red Hill, Berks, by Prestwich. The direction of the currents wearing away the clay bands and depositing the galls and sands was suggested; and these observations were offered as further materials in working out the hydrography and history of the Lower Tertiaries.—On the origin of Slickensides, with remarks on specimens from the Cambrian, Silurian, Carboniferous, and Triassic formations, by Mr. D. Mackintosh. This paper was founded on specimens a selection of which was exhibited. The author stated that his observations led him to

believe that true slickensides are produced by the movement of one face of rock against another, accompanied by partial fusion. He indicated that in many cases the slickensided surfaces are not only polished and striated, but also hardened, and that there is an imperceptible gradation from this hardened film to the ordinary structure of the rock.

**Chemical Society, March 4.**—Prof. Odling, F.R.S., in the chair.—A paper on the dissociation of nitric acid, by Messrs. P. Brahm and J. W. Gatehouse, was read by the former, and an experiment performed showing the action which takes place.—Dr. Thudichum then addressed the meeting on the chemical constitution of the brain, exhibiting a large number of the products obtained from that organ.—There were also papers on calcic hypochlorite from bleaching powder, by Mr. C. T. Kingzett; and on a simple method of determining iron, by Mr. W. Noel Hartley.

**Zoological Society, March 2.**—Mr. Osbert Salvin, F.R.S., in the chair.—An extract was read from a letter addressed to the Secretary by Dr. W. Peters, pointing out that the *Sternothaus* figured by Dr. Gray in the Society's "Proceedings" for 1873, to which neither specific name nor locality had been assigned, was *S. niger*, and that its habitat was the Cameroons, from which place Dr. Peters had received specimens.—Mr. H. E. Dresser read some notes on the *Falco labradorus* of Audubon, *Falco sacer* of Forster, and *Falco spadicus* of the same author.—Mr. A. Boucard communicated a monographic list of the Coleoptera of the genus *Phasiotis* of North America, and gave the description of several new species.—A communication was read from Mr. E. P. Ramsay, giving the descriptions of some rare eggs of Australian birds.—Mr. G. B. Sowerby, jun., communicated the descriptions of ten new species of shells from various localities.—Dr. A. Günther, F.R.S., communicated on behalf of Dr. T. Thorell, of Upsala, the description of a collection of spiders made by Dr. Vinson in New Caledonia, Madagascar, and Reunion, amongst which were a few new species.—A communication was read from Mr. E. L. Layard, H.B.C., administering the government at Fiji, giving the description of some supposed new species of birds from the Fiji Islands.—Mr. A. H. Garrod read a paper containing the description of the lower larva in some of the rarer species of Anataida. To this was added an account of the tracheal arrangement in *Platalea ajaja*, which differs much from that of the common Spoonbill. Reference was also made to the manner of development of the tracheal loop in those of the Cracidae which have recently died in the Society's Gardens.

**Royal Microscopical Society, March 3.**—Mr. H. C. Sorby, F.R.S., the new president, having been formally introduced by Mr. Chas. Brooke, expressed his sense of the honour conferred upon him, regarding it as a mark of approval of new methods and kinds of investigation, to which, rather than to the more ordinary and general subjects of microscopical inquiry, he had for many years devoted his attention.—Mr. H. J. Slack read some notes translated from Von Baer, &c., which described an organism closely allied to that recently exhibited by Mr. Badcock and assumed to be a species of *Bucephalus*.—A paper by Dr. Royston Pigott, on the principle of testing object glasses by means of images produced by reflection from globules of mercury, &c., was read by the Secretary.—Mr. H. J. Wenham described, by means of black board illustrations, a new method of viewing objects at extreme angles, and the value of this new mode of examination was explained.—Mr. C. Stewart called attention to some new and beautiful specimens of Polycistinae exhibited in the room by Mr. John Stephenson.

**Anthropological Institute, Feb. 23.**—Col. A. Lane Fox, president, in the chair.—Mr. R. B. Holt exhibited a collection of models of Esquimaux: Caiques, baidars, winter huts, summer huts, sleighs, and other objects of native manufacture.—Capt. Harold Dillon exhibited and described a series of flint arrow and spear-heads found by him near Ditchley, Oxon. The following papers were read:—On the Milanofans of Borneo, by Lieut. C. C. de Crespigny, R.N.; Further notes on the rude stone monuments at the Khasi hills, by Major Godwin-Austen; Report on the Congress of Anthropology and Prehistoric Archaeology held at Stockholm in 1874, by H. H. Howorth; History of the Heung-Noo in their relations with China, translated by A. Wylie, of Shanghai, with notes by H. H. Howorth.

**Physical Society, Feb. 13.**—The report of the President (Prof. Gladstone, F.R.S.) and Council shows that a gratifying number of physicists responded to the circular issued by Dr.

Guthrie in the autumn of 1873, and that the formation of the Society has been attended with much success in every way. The meetings were commenced under singularly favourable circumstances, as the Lords of the Committee of Council on Education generously placed the physical laboratories and lecture-rooms at the disposal of the Society, which was thus afforded unusual facilities for experimental illustrations. The first paper was on the new contact theory of the galvanic battery, by J. A. Fleming, B.Sc., and it was followed by many valuable communications. Two papers may be mentioned as being of special interest, these are: "On the combination of colours by polarised light," by Mr. W. Spottiswoode, F.R.S., and "On the application of wind to stringed instruments," by Mr. J. Baillie Hamilton.—The Society has already lost a very able member by the death of Dr. W. S. Davis, of Derby, at the early age of thirty-two.—The following is the list of officers and Council for the present year:—President, Prof. J. H. Gladstone, F.R.S. Vice-presidents: Prof. W. G. Adams, F.R.S.; Prof. G. C. Foster, F.R.S. Secretaries: Prof. A. W. Reibold, M.A.; W. Chandler Roberts. Treasurer, Dr. E. Atkinson. Demonstrator, Dr. F. Guthrie, F.R.S. The other members of the Council are:—Latimer Clark, C.E., W. Crookes, F.R.S., Prof. A. Dupré, Prof. O. Henri, F.R.S., W. Huggins, F.R.S., Prof. M'Leod, W. Spottiswoode, F.R.S., Dr. H. Sprengel, D. W. Stone, E. O. W. Whitehouse.

Royal Horticultural Society, Feb. 9.—Annual Meeting, Viscount Bury, K.C.M.G., president, in the chair.—The Report of the Council, which dealt principally with the financial position of the Society, was taken as read. The statement of accounts for 1874 showed an expenditure of 11,673*l.* 3*s.* 2*d.*, against an income of 10,877*l.* 9*s.* 11*d.*, leaving a deficit of 795*l.* 13*s.* 3*d.* This did not include rent, on account of which 2,400*l.* must be paid to H.M. Commissioners for the Exhibition of 1851 during 1876, otherwise the lease of the gardens at South Kensington will be avoided. On the other hand, the income was increased by a sum of 768*l.* 17*s.* 6*d.* paid to the society for the use of the arcades during the International Exhibition of last year. The result of the ballot for officers and council for the ensuing year was as follows:—President, Viscount Bury, K.C.M.G.; Treasurer, Bonamy Dobree; Secretary, W. A. Lindsay. New members of Council, Hon., and Rev. J. T. Boscawen, W. Longman, J. D. Chambers, F. Campion. On the motion of Mr. Godson the discussion of the report was adjourned to March 9.

EDINBURGH

Royal Society, March 1.—Sir William Thomson, president, in the chair.—The Chairman announced that the Council had awarded the Makdougall Brisbane Prize for the Biennial Period, 1872-74, to Prof. Lister for his paper on the germ theory of putrefaction and other fermentative changes, communicated to the Society, 7th April 1873. The following communications read:—Obituary notice of Mr. William Euing, by Prof. W. P. Dickson, Glasgow, communicated by the President; on a faulty construction common in skewed arches, by Mr. Edward Sang; on the mode of growth and increase amongst the corals of the Palæozoic Period, by Prof. H. Alleyne Nicholson, M.D.

PARIS

Academy of Sciences, March 1.—M. Frémy in the chair.—The following papers were read:—On the generalisation of the theory of the normals of geometrical curves, where for every normal a number of straight lines is substituted, by M. Chasles.—On some problems of molecular mechanics, by M. Berthelot. This paper was based principally on the experiments of MM. H. Sainte-Claire Deville and Debray, with perthritic acid and oxide of silver, of which an account was read at the last meeting; it treats of certain facts, newly discovered and relating to the direct formation of compounds, which upon decomposition evolve a considerable degree of heat; these facts are quoted with special reference to butyrate of soda, and from them some general deductions are made with regard to molecular mechanics.—On the capillary theory applied to Tilliaceæ, by M. A. Trécul.—Experiments on the artificial imitation of native magneto-polar platinum, by M. Dauré.—A note on magnetism, by M. Th. du Moncel.—M. Leverrier then explained to the Academy the new organisation of the meteorological service of ports, which came in force on March 1. Reports are made twice daily, morning and evening, and it is expected that the evening reports will be specially beneficial to fishing vessels.—Don Pedro II., Emperor of Brazil, is nominated correspondent to the section for Geography and Navi-

gation, in lieu of the late Admiral de Wrangel. A telegram was read from his Majesty expressing thanks for the distinction.—A memoir by M. Cabieu, on a new manure, consisting of the ashes of Meduse, picked up on the coasts, and fecal matter.—A note, by M. Chapelas, in defence of the phenomenon observed by him on Feb. 10, at Paris, which was supposed by others to be a large bolide.—On the geometrical solution of some problems relating to the theory of surfaces, and depending from infinitesimals of the third order, by M. A. Mannheim.—On the simplest modes of limit equilibrium, which can be present in a body without cohesion and strongly compressed, by M. J. Boussinesq.—A note by M. G. Fouret, on the geometrical construction of the moments of bending power acting upon the supports of a beam with several joists.—A note by M. V. Feltz, on experimental researches on the toxic principle in putrefied blood; account of experiments made upon dogs into whose veins putrefied blood was injected.—A memoir by M. Macario, on the employment of electricity in hydrocele, iliac passion (*ileus*), and paralysis of the bladder; accounts of cases that were successfully cured by electricity.—A memoir on the chemical manure for beet, by MM. H. Woussen and B. Corenwinder.—M. de Maximowitch then presented a note on a theory of integration of equations with partial derivatives of the second order.—M. P. P. Mestre made a communication respecting Phylloxera.—A note by M. H. Renan, elements and ephemerides of planet (141).—On a purple colouring matter derived from cyanogen, by M. G. Bong.—On the separation of boric acid from silica and fluorine, by M. A. Ditte.—On the reciprocal substitution of the volatile fatty acids, by M. H. Lescaeur. The author maintains that he has permanently established the following facts, namely, that acetic acid can displace formic acid from its compounds in considerable quantity, that this displacement can take place in the cold, that the presence of water does not notably affect the phenomenon, and the quantity of formic acid displaced varies according to the excess of acetic acid added.—A note by M. G. Hinrichs on the calculation of the moments of maximum inertia in the molecules of the chloro-derivatives of toluene.—Note by M. W. Louguine on the quantities of heat evolved in the formation of the potash salts of some acids of the fatty series.—On a new psychrometer which avoids all calculation, called *hygrodeik*, by M. Lowe.—On a new pourlet for volumetric analysis, by M. A. Pinchon.—Finally, five letters from different correspondents were read, all with regard to the bolide of Feb. 10, first mentioned by M. Chapelas, who afterwards thought it was only the strongly illuminated edge of a cloud.

BOOKS AND PAMPHLETS RECEIVED

COLONIAL.—The Pathological Significance of Nematode Hematozoa: T. R. Lewis, M.B. (Calcutta).—Report of Microscopical and Physiological Researches into the Nature of the Agent or Agents producing Cholera. Second Series: T. R. Lewis and D. C. Cunningham (Calcutta).  
 FOREIGN.—Principes des Sciences Absolues: James Thomson (J. Rothschild Paris).—La Terre Végétale, Géologie Agricole: Stanislas Meunier (J. Rothschild, Paris).—Sulle Variazioni periodiche e non periodiche della temperatura nel Clima di Milano: Giovanni Celoria (Milan, Urico Hoeppli).

CONTENTS

	PAGE
AGRICULTURE IN VICTORIA	361
OUR BOOK SHELF:—	
Lewis's "Pathological Significance of Nematode Hematozoa"	363
J. S. Corbould, F.R.S.	363
LETTERS TO THE EDITOR:—	
The Origin of the Jewish Week.—Dr. W. R. Smith	363
Kirkes' Physiology.—W. Percy Ashe	363
Flight of Birds.—Principal F. Guthrie	364
To Microscopists and Entomologists.—R. C. Fisher	364
"Chamæleon Barometer."—A. Percy Smith	365
OUR ASTRONOMICAL COLUMN:—	
Total Solar Eclipse of 878, October 29	365
Encke's Comet	365
Variable Stars	365
THE FRENCH TRANSIT EXPEDITION TO NEW CALEDONIA.	365
SCIENTIFIC REPORT OF THE AUSTRO-HUNGARIAN NORTH POLAR EXPEDITION OF 1872-74	366
JOHN EDWARD GRAY, F.R.S.	368
NEW ORDER OF LOCINE MAMMALS	368
METEOROLOGICAL OBSERVATIONS IN THE PYRENEES. By W. de Fonvielle	369
SCIENCE AT THE NEW PARIS OPERA, II. By M. G. TISSANDIER ( <i>With Illustrations</i> )	369
NOTES	371
ON THE DYNAMICAL EVIDENCE OF THE MOLECULAR CONSTITUTION OF BODIES, II. By Prof. CLERK-MAXWELL, F.R.S. ( <i>With Illustrations</i> )	374
SOCIETIES AND ACADEMIES	374
BOOKS AND PAMPHLETS RECEIVED	380

THURSDAY, MARCH 18, 1875

## SCIENTIFIC SURVEYS

THE almost universal idea in this country of what constitutes a Scientific Survey goes no further, we believe, than the departments of Topography and Geology, and, as we are a seafaring people, the Hydrography of our coasts. We daresay many of our readers will be surprised to hear that some whose opinions in matters of this kind ought to have great weight, deem any survey totally inadequate which does not, to a greater or less extent, include nearly every department of science. What are the prevalent notions on the subject on the other side of the water, may be learned from a Report just issued on a proposed New Survey of the small State of Massachusetts.

Last year the American Academy of Art and Sciences presented a memorial to the General Court of the State of Massachusetts, urging the necessity for a new Scientific Survey of the Commonwealth. It is forty years since there was a survey of the State; that was the first public survey in the United States, and included not only topography and geology, but zoology, botany, and agriculture as well. The biological surveys were so well done that some of the reports are even yet regarded as standard works, but the advances in all departments during the past forty years have been so great, that practically a new survey is required.

The suggestion of the new survey came appropriately from the principal scientific body of the State, and it is gratifying to see that the Legislature have such a respect for its opinion as at once to take action upon the suggestion. The memorial of the Academy was referred to the Board of Education, a committee of which took the wise course of calling to their council the most eminent men of science in the State, who could aid them with their advice. The names of most of those who were called in to give the results of their study and experience are known to science all the world over; they are Professors B. Peirce, N. S. Shaler, and E. N. Horsford; President Clark, Dr. T. Sterry Hunt, Dr. Asa Gray, Dr. A. S. Packard, Mr. G. B. Emerson (who reported on the trees and shrubs in the former survey), Mr. Alex. Agassiz, Hon. Moses Kimball, Mr. C. F. Adams, Mr. S. H. Scudder, Mr. A. G. Boyden, and Mr. H. F. Walling.

The Report which has come to hand gives an account of the meeting between these eminent representatives of science, pure and applied, and the committee of the Board of Education. Each one freely expressed his opinion of the desirableness of the proposed survey, showed how it should be conducted so far as his own department was concerned; and pointed out the advantages which would certainly follow from a thorough survey. As might be expected, they are unanimously in favour of the proposed undertaking; and the immense advantages which were shown would accrue from it if carried out thoroughly in all departments, leave the State no alternative but to organise it as early as convenient.

A special committee from among the men of science named above—Messrs. Peirce, Sterry Hunt, Shaler, and Scudder—in their Report to the Education Committee

recommmend a scale of 1 : 25000, or 2½ inches to the mile, as the scale which ought to be adopted for the survey; but this they do solely on the score of expense, admitting the superiority of the 6-inch scale. Prof. N. S. Shaler, in an impressive article in the March number of the *Atlantic Monthly*, strongly advocates the latter scale; for although the immediate cost would be at least double that of the smaller scale, still in the end it would be more economical; as, although the smaller scale would serve many useful purposes in the meantime, he declares it would be found that the survey would have to be repeated on the larger scale. We think the State of Massachusetts would be wise to profit by Mr. Shaler's hint, and accomplish the survey once thoroughly and completely on the larger scale, so that it would never require to be repeated. Indeed, the United States have had several lessons on this point; a considerable number of the States have been surveyed, but the surveys have all been more or less failures; "there is not a single survey in this country," Prof. Shaler states, "which does not need at the moment to be done over again."

The practical advantages of topographical and geological surveys are so evident that it is unnecessary to point them out; no one, we presume, will deny that it is the interest and duty of every civilised country to obtain a complete and trustworthy knowledge of the extent, configuration, and composition of its surface. The important practical advantages which may result from a thorough geological survey have been well illustrated by a recent undertaking in America—the Hoosac Tunnel. It is Prof. Shaler's belief that "a due inspection of the surface of that ridge would have disclosed some of the difficulties encountered in the excavation of the tunnel, difficulties which would have been in a large measure avoided, had the engineers been forewarned. It does not seem too much to say that the cost of a complete survey, with a map on the scale of six inches to the mile, might have been saved by this easily gained knowledge."

But the State of Massachusetts has already had the wisdom to perceive that it is for the material advantage of a country that a knowledge of more than its topography and its geology should be easily accessible. To a thickly populated country, what can be of more moment than its hydrography, its water supply, which is also of so great importance in connection with manufactures? In the proposed survey of Massachusetts a thorough knowledge of its hydrography will probably be considered as an indispensable part of the work. It seems almost a truism to say that in a country devoted to agriculture, an exhaustive scientific examination of its soil would be a work of the greatest national advantage; such an examination has been to some extent made in Massachusetts, and the scientific men whose advice has been asked urge that it should be carried out over the whole of the State.

The practical advantages to be derived from a knowledge of the botany and zoology of a country, especially a country where agriculture is one of the staple industries, seem almost equally apparent. If our farmers were well acquainted with all the plants and insects and birds which annually destroy so large a quantity of the cultivated produce of the soil, and at the same time knew how to meet their ravages, the saving to the nation would be enormous. Dr. A. S. Packard estimates that in Mas-

sachusetts alone they lose every year, from insects and parasitic plants, 500,000,000 dollars; and that in one year alone they lost by the army-worm 250,000 dollars' worth of hay-crops. No wonder he says, "Certainly it will be a good thing to have a body of observers at work systematically, year after year, collecting information, which may be spread before the farmers of the State and others interested." In this connection the words of Mr. A. G. Boyden are worth quoting:—

"The relation of the animal to the vegetable kingdom is a most intimate one. In the cultivation of orchards, garden vegetables, and things of that sort, upon which we as a people depend a great deal, we have to contend continually with insects; if we could learn, therefore, the facts about the insects that are found in this State; if we knew how they were generated, how they grow, and what they feed on, we might do a great deal towards saving a large part of the crops that are now destroyed by them. For instance, the canker-worm comes periodically, and very few people know much about the habits of this insect. Very little is known about insects by people generally. They do not even know them by name. They do not recognise an insect in the three stages of its life. Every gardener, every orchardist, every person cultivating herbs, trees, or shrubs, needs this information. As has been said this morning, we have not the books to which we can go for help in gaining this information. . . . Mr. Emerson has given us an excellent book on the trees of the State, which is a very great aid, but in respect to the other matters of which I have spoken, we have very few such helps as are needed. It would seem, therefore, that a survey of this kind, in which scientific men were employed, who could, as they went over the different localities of the State, collect, incidentally, and without adding very much to the expense, the facts relating to these subjects, would be of great value."

The body of evidence contained in the Report before us seems to us to show clearly, what indeed is almost self-evident, that one of the first duties of a nation, from the lowest point of view of self-interest, is to obtain a complete scientific knowledge of its home and all that it contains; only thus can it be able to make the most of its natural resources.

While the great practical advantages of the survey were insisted upon, the gains to science and to education which would accrue from it were also brought prominently forward. Some important problems in science, it was shown, might be solved by a thorough geological and biological survey of Massachusetts; one of the most important of these is in connection with Cape Cod.

"Here, in Massachusetts," Prof. Shaler says, "you have certain peculiar questions connected with the distribution of animal life to the north and south of Cape Cod, which offers one of the most remarkable illustrations of the variations in the distribution of animal life that is afforded anywhere in the world. The constant changes as years go by, the influence of temperature on the distribution of animals, these are questions which can be investigated there. There is no question that Cape Cod is one of the great problems of Massachusetts, and it is a problem on which a large number of investigations should be hung. Prof. Peirce, who has carefully traced and grouped the facts connected with that part of the coast, will agree with me in saying that Cape Cod is the key-point; that geologically it is the most important point in Massachusetts, with regard to the agencies that have been at work in the creation of the soil, especially with reference to the glacial period, &c."

With regard to education, it was shown that in several

ways this exhaustive survey would be of great value. It was proposed by some that the scientific students in the several colleges might with advantage to themselves be occasionally employed on the work, while they might be of some assistance to the survey-parties; this plan, if judiciously carried out, might indeed be of great service both to the students and to the work of the survey. Prof. Shaler pointed out that what he thinks the principal defect of the British Survey does not concern its work, but its effect upon British science. "It has not taken pains," he said—and we cannot take upon ourselves to judge of the justice of his statement—"to connect itself enough with the work of education in Great Britain; and the result is, as is admitted by some of the oldest geologists there, that there are few young geologists coming up in England at this time." This, if true, is certainly a great lesson for Massachusetts, as Prof. Shaler says; we hope, however, he has overstated the case, or at least that the supply of geologists in this country is not dependent on the Geological Survey. It was shown that in other ways a complete survey in all departments would be of the highest advantage in carrying on the practical education of the young in schools of all classes; and that from want of the results of such a survey, education was seriously hampered.

It will thus be seen that if in the course of years—for it is proposed to do the work leisurely and allow eminent scientific men to share in it as they can find opportunity—the people of Massachusetts do not have one of the most accurate and most complete surveys in the world, it will simply be because they are blind to their own real interests, which have so forcibly been brought before them by some of the most eminent of their scientific men, in whom the State is so rich. But as "the commonwealth of Massachusetts has not been wont long to weigh great advantages against small expenditures, so we may safely anticipate," with Prof. Shaler, "her speedy action."

Need we point any moral for ourselves from the liberal and comprehensive ideas which the comparatively small (its extent, 7,800 miles, is only about that of Wales) and young State of Massachusetts has of what a survey of her territory includes? We have our topographical and our geological surveys, both doing excellent work, and both already productive of large practical and scientific results. But if we want to make the most of our small and over-crowded country; if we want, as we certainly should if we have our own welfare at heart, to have a complete knowledge of our country's resources, why should we stop short at topography and geology? Forty years ago Massachusetts showed itself to be far wiser than Britain is even now. Even then the little Transatlantic State saw it to be to its best advantage to know all about its soil and its natural products; we do not know that the question has ever been mooted in this country. A knowledge of what is being done on the other side of the water may give us a perception of our true interests and our duty to ourselves and the world. To apply the words of Prof. Shaler: "Look at it as we may, measuring its immediate gains to our mines, our fields, our water-mills, to our cities in their water supply and sewage, to our railways and common roads, to the interests of each owner of an acre that is to be improved; or considering

the remoter yet not less real economy which is found in increased knowledge of the Nature about us, and in the advancement of education, the reasons for Survey this are very strong."

#### THE COUNTESS OF CHINCHON

*A Memoir of the Lady Ana de Osorio, Countess of Chinchon and Vice-Queen of Peru; with a plea for the correct spelling of the Chinchona genus.* By C. R. Markham, C.B., F.R.S. (London: Trübner and Co.)

THIS work is an attractive addition to the early history of quinine and the other alkaloids derived from the same source. The general subject is full of interest to numerous classes of the community, and the importation of plants into our Indian possessions has been the subject of much attention on the part of our Government. Indeed, it was the result of the author's exertions that living specimens were obtained in this country, and by this means that India was supplied; it is therefore natural that he should take a parental interest in this matter.

The knowledge of the efficacy of these drugs was brought to Europe in the year 1640 by the Countess of Chinchon on her return to Spain with her husband at the expiration of his term of office as Viceroy of Peru. This lady during her residence there was attacked by tertian fever, and after being reduced to the point of death, was, under romantic circumstances related by the author, cured by the use of Peruvian bark. On the return of the count and countess to the castle of Chinchon, it is gratifying to read that the countess, who had brought with her a supply of the precious bark which had effected such a wonderful cure upon herself, "administered Peruvian bark to the sufferers from tertian agues on her lord's estates in the fertile but unhealthy *vegas* of the Tagus, the Jarama, and the Tajuña. She thus spread blessings around her, and her good deeds are even now remembered by the people of Chinchon and Colmenar in local traditions" (p. 45).

Though from time to time during the succeeding hundred years powders of the Peruvian bark were imported into Europe, it seems that no scientific account of the tree was published until 1740, in which year De la Condamine published a description and figure in the Memoirs of the Academy of Paris for 1738, under the generic name of *Quinquina*. This communication contained also an account of the history of the drug, wherein the name of the Countess of Chinchon was duly mentioned and properly spelt, and on the information obtained from it and quoted in acknowledgment, Linnæus, in the second edition of his "Genera Plantarum," published at Leyden in the year 1742, founded his genus *Cinchona* in honour of the Countess of Chinchon.

The author commences his book by tracing the pedigrees, accompanied by coloured illustrations of the armorial bearings, of the families of Ana, Countess of Chinchon, and of the Count of Chinchon; nor does he omit to describe and illustrate the town, neighbourhood, and castle of Chinchon. The town contains some 6,000 souls, and its distance south-east from Madrid is given as twenty-four miles.

But it is reserved to the end of the book to treat of a

matter which evidently lies deeply seated in the author's affections; unless for its sake the book would probably never have been written. This is a vigorous argument, called in the title a plea, for what he considers to be the correct spelling of the generic name.

The author's object is to prove that the name *Cinchona* should be replaced by *Chinchona*, and he argues that the latter form is etymologically right, that Linnæus was misinformed as to the true spelling of the countess's title, that it is supported by the majority of authorities who have studied the genus in its native *habitat*, and is now the form in common use where the plant is cultivated, as well as in official correspondence, and that it is consequently the most convenient form. He further states that the former spelling has never been generally adopted.

In the matter of etymology the author is certainly right, but neither botanists nor the public are simply led by this rule when more important considerations require a different course; botanists have greater regard to priority and the public to general convenience, and both in respect of priority and convenience *Cinchona* is the more correct word.

It has been already explained that Linnæus was not misinformed as to the spelling of Chinchon; and it is therefore probable that he considered euphony in forming the name, in accordance with his aphorisms: *Terminatio et Sonus nominum genericorum, quantum fieri possit, facilitanda sunt. Nomina generica sesquipedia, enunciata difficilia vel nauseabunda fugienda sunt.* Thus, in honour of Barrelierus, Linnæus named Barleria, and in many other cases he sacrificed strict etymology to elegance and convenience.

Mr. Hanbury, in the *Athenæum* for January 30, has shown that, in the course of a long correspondence with Linnæus, Mutis; though in his earlier letters he spelt the name *Chinchona*, yet in his later letters he followed the spelling of Linnæus, and wrote *Cinchona*; also, that in 1758, J. Ch. Petersen read at Upsala an academical dissertation, "*De Cortice Peruviana*," Linnæus presiding, and in this paper he always spelt the word *Chinchona*; this is, however, not a botanical essay.

Linnæus, in all his other works and editions, always retains his original spelling. The author erroneously states that Linnæus altered the spelling in his different editions, and draws the inference that Linnæus was willing to modify his original spelling and desired to spell the word correctly. In the sixth edition of the "Genera Plantarum," published at Stockholm in 1764, on p. 91 the word is accidentally spelt *Cinchona*, but this was clearly a typographical error; for in the synopsis of the genera of Pentandria, on p. 69, it is spelt *Chinchona*, and so again in the index to the volume; and if further proof is wanted, the error on p. 91 was given in the errata and corrected. In the edition of 1767, printed at Vienna, which is without the authority of Linnæus, and is, in fact, only a reprint of the sixth edition, the same spellings occur in each place, except that we find in the errata, *Cinbona* (instead of *Cinchona*) corrected into *Cinchona*.

So universal was the authority of the Linnæan spelling, that no botanical treatise published and adopted a different one until the year 1862. The name *Chinchona* does not occur in Steudel's "Nomenclator Botanicus," second edition, published in 1840-41.

With regard to the botanical authorities that the author claims for his spelling, Mr. Hanbury has shown that Ruiz, Pavon, and Mutis rather incline the other way; Ruiz and Pavon, in their great work, the "Flora Peruviana," &c., adopted *Cinchona*, and Mutis finally came to the same conclusion. Mr. Spruce, another of the claimed authorities, in the Journal of the Linnæan Society, writes *Cinchona*, though in certain Blue Books he writes *Chinchona*. It must be remembered that such Blue Books appear to have been prepared under the direction of the author in his official capacity at the India Office, and to have had the word *Chinchona* forced into prominence. There remain only Tafalla, a pupil and successor of Ruiz and Pavon, Zea and Caldas, pupils of Mutis, all three of but little importance, as well as Dr. Seemann and the author, to weigh against such authorities as Humboldt and Bonpland, Poeppig, Weddell, Triana, Karsten, and others, as well as the universal concurrence of all the great systematic botanists from the time of Linnæus to the present day.

If then this question is to be settled by the weight of usage and authority, it is evident that an exceedingly rough balance suffices to give a ready result unfavourable to the author's case.

It is equally clear that much inconvenience would ensue from the change proposed and adopted by the author. To the systematic botanist great would be the inconvenience of altering the second letter of a generic name the first letter of which is C, an initial which is commoner than any other, and which stands for about one-seventh part of the whole number of genera. The suggestion that in an index a cross reference would meet the difficulty is good to a certain extent, but it would not altogether remove the nuisance; nor would the chemist, the apothecary, and the public generally accept without repugnance a change which would affect the spelling and damage the pronunciation not only of the original word, but also of derivatives in frequent use such as Cinchonine, Cinchonidine, Cinchonidine.

In short, the Linnæan name *Cinchona* is no longer under the control of the Countess of Chinchon, nor of the town of Chinchon, nor yet of those enamoured of either; it sufficiently recalls the memory of the benevolent countess; but it has long become scientific and general property, and stands by the right of usage and priority; it has a settlement due to a century and a third of time, and neither scientific men, nor the commercial world, nor the general public will be likely to alter it and the several words derived from it on the plea set up by the author.

W. P. H.

GERLAND'S "ANTHROPOLOGICAL CONTRIBUTIONS"

*Anthropologische Beiträge.* Von Georg Gerland. (Halle an der Saale: Lippert'sche Buchhandlung, 1875.)

THE present volume is, as the author informs us, only the first of a series of several volumes, in which it is his intention to group together as far as possible all the aspects under which the modern science of anthropology may be considered; to weigh the importance and estimate the nature of the problems which it has to solve; and to bring clearly and objectively before the reader the dif-

ferent steps that have been attained, or are demonstrable by facts, in the history of the origin and subsequent development of mankind.

The difficulty of the task which Dr. Gerland has thus set himself seems to us to be only equalled by the probable remoteness of its accomplishment. We all know that there is a tendency amongst German writers to project works on too colossal a scale, and to fill in their ground with such inexhaustible masses of detail, that every fresh accumulation of facts becomes a mountain across their readers' path, tending to obstruct rather than to clear the view; and valuable as are the materials which Dr. Gerland has brought together, his "Anthropological Contributions" cannot be pronounced free from these tantalising failings. Those who have time and patience to follow the author along all the collateral lines of inquiry into which his subject is incessantly divaricating will no doubt find themselves repaid for their labour; but the anthropologist, who has neither the need nor the leisure for going over old ground in search of new facts, will find it difficult to sift the wheat from the chaff.

In his introductory chapter Dr. Gerland considers all the branches of human inquiry with which anthropology is associated; the importance of missionary enterprise in relation to its bearing on the extension of our anthropological knowledge; and the influence that the estimate in which women have been held among any definite people, or at any fixed epoch, has had in modifying the *morale* and *physique* of the entire sex.

In the second, or main section of the work, the author treats of the primary and developmental history of man from the evolution point of view. Setting aside the hypothesis of special creation as utterly untenable, and as wholly discarded by every rational anthropologist, he proposes to consider man as derived by mechanical means from a natural animal source; beginning his line of argument by a discussion on the relative claims of the different portions of the habitable world to be regarded as the cradle of the human race. In this section of his work Dr. Gerland shows a vast amount of curious learning, and brings together a valuable mass of facts relating to the past as well as present fauna and flora of different regions, and their consequent greater or lesser adaptability for the coexistence of man. He considers the fact that the African races depend for their food-supplies on plants such as the sorghum and other cereals, which have come from Asia, although their own continent possesses many edible indigenous plants to which recourse is had in times of emergency, as a proof that man did not take his origin in Africa, for it is wholly irrational to suppose that after having once used native-grown cereals in their primary condition, men should have neglected these in favour of others imported from another continent like Asia.

In discussing the probable period in the earth's history when man appeared, the author insists upon the absolute necessity of geognostic repose as an indispensable element in the development of man from an animal origin. Cataclysms and violent disturbances of the earth's crust are obviously incompatible with the free enjoyment of all the essential requirements of animal existence, without which any advance in the developmental order of such an existence is inconceivable. In conclusion, he claims to

have proved that we have solid grounds for maintaining that man, considered both in his psychological and his physical nature, has been developed gradually and normally, and must be regarded as a link in one and the same serial chain of development to which all other organic bodies belong. Furthermore, he asserts that we cannot regard the organic and the inorganic as of heterogeneous origin; such an assumption would militate against the unity of the universe; and therefore we must assume that the organic has been developed from the inorganic. As development depends upon attraction and motion, and assimilation regulates the combinations of atoms and molecules, the ultimate development of more highly organised bodies is dependent upon the assimilation of more perfect combinations of matter, or, in other words, on better food, and hence the striving of the animal nature to obtain definite forms of nourishment must of necessity have exercised a paramount influence on its higher development. Thus, he argues that the organs of the senses, as sight, taste, &c., resulting ultimately in the formation of brain and nerve centres, have been developed in the vicinity of the mouth as auxiliaries in the process of nutrition. The author believes that every group of organisms has a definite supreme beyond which it cannot ascend: and while he considers that, mentally and psychically, the best of the human race will probably in remote future ages be able to attain a higher degree of perfection than any allotted to us in the present age of the world, he does not anticipate that externally they will differ greatly from ourselves.

The difficulty of answering why animals no longer pass the bounds of their parental types, he meets by assuming that the cosmical, natural, and geognostic relations which rendered such an advance possible in the case of the human race, and of the forms from which it was directly developed, no longer exist, and that hence the lower animals must remain fixed within their several limits.

We do not know how far his German readers may approve of the phonetic mode of spelling adopted by the author, but we confess that, notwithstanding the high authorities which it advocates advance in its justification, we fail to recognise its expediency or desirableness, and greatly prefer the ordinary mode.

OUR BOOK SHELF

*The Aerial World: a Popular Account of the Phenomena and Life of the Atmosphere.* By G. Hartwig, M. and P. D. With eight Chromoxylographic Plates, a Map, and numerous Woodcuts. (London: Longmans and Co., 1874.)

DR. HARTWIG is already well known as one of the most successful popularisers of the results of scientific research; and judged of from the point of view from which they are written, his books must, we think, be reckoned as of considerable value, and as likely to be of much use, both in spreading accurate scientific information and in giving their readers a taste for further independent study of science. Under present conditions we deem works of this class a perfectly fair means of scientific propagandism, hoping all the same that the time will come when the gospel of science will need no allurements to make it attractive to the people. In this volume Dr. Hartwig gives a vast amount of information on a great many subjects intimately or remotely connected with the air. It is not merely a popular treatise on Meteorology,

which of course has a large share of space devoted to it, but it contains as well much information on Sound, Light, Aërolites, Geology, Ocean Currents, Flight of Birds and Insects, Aërostatics, and many other things in "the heavens above, the earth beneath, and the waters under the earth." All the information in the book is valuable and rendered attractive mainly by a profusion of anecdotes, on the whole happily introduced. Dr. Hartwig's style is fluent and generally agreeable, sometimes eloquent and occasionally florid. His information, collected from a vast variety of sources, so far as we have tested it, is accurate and well up to time. We sincerely wish the work a large circulation. The numerous illustrations add in the main to its attractions.

LETTERS TO THE EDITOR

[The Editor does not hold himself responsible for opinions expressed by his correspondents. Neither can he undertake to return, or to correspond with the writers of, rejected manuscripts. No notice is taken of anonymous communications.]

A Gyrostat Problem

THE following question, taken from an examination paper set to the students of the Natural Philosophy Class in this University, Sir W. Thomson desires me to send to NATURE, as one likely to be interesting to its readers. The answer will be sent later, when the examination is over:—

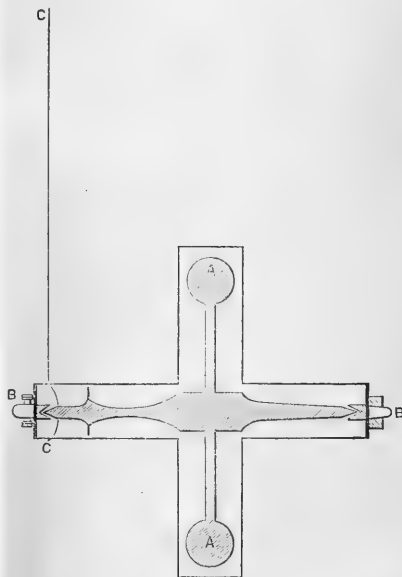

"A gyrostat, hung by a cord CC at a distance of six centimetres from its centre of gravity, keeps its axis BB horizontal when turning in azimuth at the rate of one-fourth of a radian\* per second. How many revolutions does the fly-wheel AA make per second? The weight of the wheel and case is 2,250 grammes, the mass of the wheel alone is 1,800 grammes, and its radius of gyration is four centimetres."

The University, Glasgow, March 13 D. McFARLANE

\* The term radian has been recently introduced by Prof. James Thomson to denote the unit angle, that is, the angle subtended by an arc equal in length to the radius.



## Origin of the Chesil Bank

IN your report (vol. xi. p. 299) of the paper on this subject by Prof. Prestwich, read at the Institution of Civil Engineers, are these words:—"The large dimensions of the bank he attributed to the great accumulative and small lateral action of the waves." Why, then, does not so general a cause form hundreds of such banks? Why is "the great accumulative action of the waves" confined solely to the Chesil Bank, and particularly to the Portland end of it? Because the travelling of the pebbles is towards Portland, which checks the travelling, and so allows of "accumulation" exactly as a grain does. This is the simple "open sesame" of the secret; and if we could build grains as large as Portland, every one of them would "accumulate" a bank of precisely the same conditions as the Chesil Bank. If the pebbles travelled from Portland, as the professor thinks, that end of the bank should be the lowest; it would be perpetually robbed by the waves. But it is the highest—forty-three feet; and the Abbotsbury end, to which he supposes the pebbles to travel, should be the highest, but it is the lowest—scarcely more than half the height, twenty-three feet; while at Bridport there should be a still higher bank, for the professor makes the pebbles travel from east to west there and meet the pebbles which had "travelled from the opposite direction, viz., from west to east." But at Bridport there is not a single pebble, but only blown sand.

That the largest pebbles accumulate at the leeward end of beaches is not a matter of opinion, but a matter of fact, and the fact may be seen at every groin in the world. So that the large pebbles at Portland, instead of testifying against the travelling from west to east, testify conclusively for it. If there is anyone who can suppose that the diminishing of the pebbles in size from Portland to Abbotsbury results from the wearing in traveling that distance, there can be no one who could give this cause for the same result between two groins. The cause which I have assigned (chapter on "Travelling of Sea Beaches," Rain and Rivers) for the lodgment of the largest pebbles at the Portland end, is that where motion is given to pebbles the largest will be on the outside; they are therefore most amenable to the upward and onward stroke of the wave, and they travel fastest and furthest down wind on these beaches.

With regard to the modern beaches being recompositions of ancient raised beaches, besides the travelling, their pebbles are perpetually pounded by the waves till they are ground into sand. The professor dates the Portland raised beach to the Glacial Period. We have ample time, then, for its pebbles to be ground into sand and replaced by new comers. And the new recruits would not come, as the professor thinks, solely from "the cliffs," but chiefly from the mouths of the rivers which bring pebbles from all the various strata of the interior of the land without the aid of ice; for atmospheric disintegration and the erosion of rain denude the entire surface of the earth, and let down to the rivers not only soft soil but hard gravels and stones from every the most remote hill-top. But this huge traffic is brought to the rivers by rain. Rivers are simply the roads which it travels to the sea. What is held in suspension goes out to deep water, but the gravels, stones, and boulders are pounded and ground into the sands of the sea-shore.

GEORGE GREENWOOD

Alresford, March 2.

## Natural Phenomena in South America

IN Mr. J. Munro's very interesting notes made during a cable-laying expedition from Pará to Cayenne, which were published in NATURE, vol. xi. p. 329, the following passage occurs upon which comment may be useful. After describing a beautifully coloured Crustacean, and an animal which he speaks of as a crab or water-beetle, Mr. Munro goes on to say: "Another creature (Fig. 3) of quite a different description was also picked up. It was more like a water-spider than anything else. Its transparent hair-like limbs were dappled with dull green, and it seemed a mere skeleton framework made to carry a small white sac containing entrails, which was slung underneath." From the figure it is tolerably evident that this creature is one of the Pycnogonidae, whose place in a classification of the animal kingdom is scarcely yet definitely settled, but which are ranged by Prof. Milne-Edwards among Crustaceans. It seems highly probable, then, that "the small white sac containing entrails" should rather have been described as a pair of very slender legs carrying egg-bags. This at least would be in accordance with what is known of other species of Pycnogons, none of which carry their entrails in sacs slung underneath.

The delicate spider-crab (Fig. 1), which charmed Mr. Munro with its hyaline limbs and varied colouring, seems from the figure to be nearly allied to the genus *Stenorhynchus*. The affinities of Fig. 2 cannot be guessed at without additional details.

It is likely enough that all the creatures mentioned may be specifically new.

THOMAS R. R. STEBBING

Torquay, March 10

## Volcanic Action in the Sandwich Islands

IN your notice of my book, "The Hawaiian Archipelago," (vol. xi. p. 322), you allude to the statement that volcanic action on the Sandwich Islands "has died out from west to east." It has also died out in a southerly direction, through nearly four degrees of latitude. In the pit of Hale-mau-mau within the crater of Kilauea, on January 30, 1873, the violently agitated mass of lava continually took a southerly direction, and broke in very elevated surges upon the cliffs on the south side of the lake. On June 4, 1873, when the aspect of the pit had undergone a very great change, there was a violent centripetal action, but the sort of rotating whirlpool continually formed, invariably rotated in a southerly direction. Some years ago, during a terrible eruption of Kilauea, when a river of lava from 200 to 800 feet wide, and an estimated depth of twenty feet, was running towards the sea with an estimated velocity of twenty-five miles an hour, four large "fire-fountains" boiled up when the stream issued from the earth. An intelligent observer, Mr. Whitney, noticed that the lava was ejected with a rotary motion, and that both the lava and stones thrown up rotated towards the south. I should be very glad to know any probable explanation of these phenomena, and if this apparently persistent southerly extinction and motion have any and what value as scientific facts?

Mr. Munro (vol. xi. p. 329) describes the locking together of trees of different species in the neighbourhood of Pará. The instances of this in the Hamakua forest on Hawaii are very numerous and striking. The Ohia (*Metrosideros polymorpha*?) is seen in the closest conjunction with the large tree-fern of the district, with a universality which leads some people of more than average intelligence to assert dogmatically that the fern is the invariable parent of the Ohia! The junction is so intimate as to be apparent interpenetration. The greatest height of any tree-fern that I have measured is eighteen feet of caudex; but I have seen Ohias with an estimated height of eighty or ninety feet carry the tree-fern with them to a height of fully thirty feet, the fresh pea-green fronds branching out from among the dark leaves and deep red blossoms of this very handsome evergreen.

6, Alva Street, Edinburgh, March 3 ISABELLA L. BIRD

## The Height of Waves

THE height of waves has long been a vexed question amongst all classes of theoretical and practical observers. The late Admiral Fitzroy has left on record that on one occasion the measurement from crest to hollow was seventy feet. The figure seems high, but close and varied observations made during a storm on the passage from Liverpool to New York, in January, convince me of the correctness of the Admiral's statement. In this storm, for the first time on record, large ocean steamers were rounded to with a fair wind, the universal opinion being that it was too dangerous to run with the sea far on the quarter. The captain of a German steamer, on arriving at New York, spoke in enthusiastic terms of the grand spectacle a White Star steamship presented as she "leaped from wave to wave like a gigantic fish," adding: "I am sure she must have hove to in the end."

This remarkable gale swept over a portion of the Atlantic which the French call "Le trou de diable," and it well merits the designation. Roughly, its focus may be considered to be in 45° N. and 40° W. When the wind sets in strongly from the north-west, the sea rises in an incredibly short space of time; and at the close of a long winter gale it is a grand sight to watch the great waves as they roll up astern at the rate of twenty-five miles per hour, sweep by the ship, and break far ahead. There is a feature in connection with the waves of the Atlantic which is worthy of notice, viz., with a south-west or southerly gale their height is insignificant. A practical proof of this is that large steamers run in the trough of the sea without inconvenience; but with less wind from the north-west they have occasionally to be kept off their course to avoid damage to boats. What occasions this remarkable phenomenon? It cannot be the "fetch," as seamen

term it, for in some positions the southerly is the longer. Neither can it arise from the lack of force on their part, for they often blow for days at a time, and the total number of foot pounds acting on any particular spot must be enormous. Again, a north-wester during winter or summer tears the surface of the water as if a harrow had passed over it, while the southerly gale leaves no trace behind, save the ordinary break of the crest. These are facts known to everyone who crosses the Atlantic, but no satisfactory explanation of their origin has yet been given.

I give the data from which my observations were made, in order that anyone may draw his own conclusions. This ship is 450 feet long on the upper deck, and the fore yard is 62 feet above the level of the sea. From a position 239 feet abaft the foremast, where the height of the eye was 27 feet, the crests of the advancing waves at times appeared above the fore yard. Estimated distance between the crests of the waves, two-and-a-half times the ship's length.

Celtic, Feb. 13

WM. W. KIDDLE

OUR ASTRONOMICAL COLUMN

VARIABLE STARS.—The following are the dates of maxima and minima of variable stars occurring in April, May, and June, according to the elements of Prof. Schönfeld (1875), stars with short periods being omitted; unless otherwise expressed the date is that of a maximum. The positions of these variables are doubtless in the hands of observers generally.

April 1	T Ursæ Maj. min.	May 23	R Virginis, min.
15	R Bootis, min.	23	R Scuti, min.
2	S Aquarii.	28	R Sagittarii.
3	T Canci, min.	29	R Ceti.
4	R Sagittæ, min.	31	S Cephei, min.
8	R Vulpeculæ, min.	June 1	R Piscium.
13	γ Gemm. min.	1	S Ophiuchi.
14	R Geminorum.	12	T Serpentis.
15	S Vulpeculæ, min.	11	R Vulpeculæ.
17	R Scuti.	13	R Sagittæ.
25	S Aquilæ, min.	15	R Leonis.
28	U Virginis, min.	20	T Cassiop. min.
May 3	R Canis Min. min.	21	S Vulpec. min.
3	R Corvi.	23	R Persei.
13	S Vulpeculæ.	24	S Coronæ.
16	β Arietis.	24	R Scorpil.
19	R Leonis Min.	25	S Herculis, min.
19	S Hydræ.	27	R Scuti.
19	U Herculis.	28	R Camelop.
20	S Leonis.		

"Linea" communicates the result of his examination of  $\Sigma$  747 on March 9; the magnitudes appeared to be 7 and 8, as in the last Greenwich Catalogue, the smaller star *s.p.* If "Linea" refers to *Astron. Nach.* No. 2026, he will see from the position there given by Herr Falb for his new variable star, that there is no doubt of its identity with the preceding component of the above double star. It is also No. 10527 in the reduced catalogue of Lalande, and No. 274 in the volume of observations made at the Radcliffe Observatory, Oxford, in 1872, which has been circulated during the last week.

Mr. Birmingham, of Millbrook, Tuam, in *Astron. Nach.* No. 2028, draws attention to a star of 7th magnitude in Monoceros, which he appears to consider new. On Feb. 14, rough measures gave its position in R.A. 7h. 24m. 22s., Decl. 10° 4' S.; the colour was reddish-yellow. On looking to the sky, it is evident that the R.A. as printed is nearly one minute too great, and the star is identical with Lalande 14599, estimated 1797, Feb. 27, of the 6th magnitude. Lalande's place brought up to the beginning of the present year is R.A. 7h. 23m. 27s.1; N.P.D. 100° 4' 12". The star is entered 6 on Fellecker's Berlin chart, but is not found in any recent catalogue. In all probability Mr. Birmingham has detected a new variable star. On March 14 it was very little below the 6th magnitude, and, in a hazy sky, had a deep yellow light.

MARS AND 3 SAGITTARII, 1875, JUNE 29.—A very close approach of this planet to the fifth magnitude star 3 Sagittarii will take place during the night of June 29;

indeed, with Leverrier's place and adopted diameter of the planet, the star would be occulted for a few minutes by the northern part of the disc, at the Observatories of Cordoba and Santiago de Chile. The phenomenon will not be visible in this country. The much-desired observation of the occultation of  $\psi$  Aquarii on the 1st of October, 1672, during Richer's expedition to Cayenne, was lost, through a clouded sky, and from the same cause Rümker, at Paramatta, was prevented observing an occultation of 446 (Mayer) Leonis, on the 16th of February, 1822.

ENCKE'S COMET.—Inquiries arrive from the southern hemisphere with respect to the path of this comet after perihelion passage. The elements determined for the present year, after including the perturbations of Mercury, Venus, the Earth, Mars, Jupiter, and Saturn, are as follows according to Dr. von Asten:—

Perihelion Passage 1875, April 13<sup>o</sup> 08' 15" G. M. T.

Longitude of perihelion	... ..	158° 13' 9"	Equinox of
Ascending node	... ..	334 32 19'	1870 <sup>o</sup>
Inclination	... ..	13 7 17"	
Angle of excentricity	... ..	58 8 56"	
Mean daily motion	... ..	1079'' 2209	

The editor of *Astronomische Nachrichten* having notified his intention of reprinting Dr. von Asten's ephemeris, which extends to the middle of August, in his next number, it may suffice to give here a few positions to indicate the general track of the comet. The places are for Berlin noon:—

	R.A.		N.P.D.		DISTANCE FROM	
	h.	m. s.	°	'	Sun.	Earth.
May 15	0	36 23	105	43' 5"	0' 822	0' 564
" 25	0	8 48	110	31' 4"	0' 995	0' 580
June 4	23	41 36	114	43' 5"	1' 156	0' 590
" 14	23	9 54	118	48' 6"	1' 306	0' 600
" 24	22	31 13	122	33' 9"	1' 448	0' 619
July 4	21	46 43	125	21' 9"	1' 581	0' 659

After Encke's comet is beyond our reach, nearly two years will elapse before any other known comet of short period is visible. Neglecting perturbations, D'Arrest's comet would arrive at perihelion again in the middle of April 1877, but the circumstances would not be favourable for observation.

THE TRANSIT OF VENUS

AS we intimated last week, news has now been received more or less from all the Kerguelen parties. Details of the observations of these and other parties appeared in last Thursday's *Times*, and we shall here endeavour to present the principal astronomical results.

The weather on the island during the transport and after the landing of the various parties was horrible; the day before the Transit was one of the most trying kind, and at night the barometer was falling, and any observations on the morrow seemed hopeless. By a freak of the southern skies, however, on the morning of the 9th the sun rose without a cloud; but a bank began to form soon after sunrise. From the despatch of Capt. Fairfax, of the *Volage*, we learn that at the principal English station "the sky was cloudy and there was little wind. Venus was seen to break into the sun's disc, but before the internal contact a cloud had obscured the sun. Several observations and photographs of the sun were taken during the forenoon, and the internal and external contacts at egress were observed." At the other English stations and at the American stations the contact at ingress, but not at egress, was obtained. The Germans got both contacts at ingress and egress. The astronomers are pleased with their success. From an account of the observations made by the Americans, communicated by one of themselves to the *Capetown Standard and Mail*, and quoted by the *Times*, we learn that, all things considered, their success was great.

"The perfection of the calculations was surprisingly wonderful.

Not only was the angle of calculation drawn exactly, but the computed time was drawn to the nearest minute. After first contact, the measurement of cusps proceeded at intervals of five seconds. Near the moment of second contact, a cloud interposed, but it cleared away almost instantly, and enabled the astronomers to obtain the moment of second contact a little late, and to proceed with the measurement of distances of the limb of Venus from the sun's limb. This ended the part of the astronomical observers for the time being. Meanwhile the photographers were hard at work. During this time, half an hour, no fewer than forty-five photographs were taken of the sun. From this time until the Transit was over, photographs were taken whenever breaks in the mist gave the opportunity, the mist growing into clouds as the day wore on, gradually shutting out the sun from sight. In all, sixty-five photographs were obtained, including several of the different stages of egress."

Our readers will no doubt remember what has been said about the high strategic value of Kerguelen. "For the Delislean method," to quote the article in the *Times*, "relied on by the English chiefly, it is the station at which (the Crozets being unoccupied) ingress was most retarded. Next in value to it from this point of view came St. Paul's Island (of which more presently), and then Bourbon, Mauritius, and Rodrigues.

"Further, the entire Transit was visible from Kerguelen, therefore observations of duration could be made, and therefore it was a Halleyan station, and let us add, the Southern Halleyan station of the very highest value. Thus, combining observations made at Nertchinsk and Kerguelen, we get a difference of duration of thirty-two minutes; the more easterly group of stations lying round New Zealand combined with Nertchinsk, only giving a difference of some twenty-eight minutes at the outside; and Mauritius, combined with the same place, only giving twenty-four minutes. For the photographic or direct method also it was of the highest importance, combining the photographs taken with those secured in Siberia and India. We are now, then, in a position to analyse the telegram. Observations of ingress retarded to combine with the observation of ingress accelerated, made at the Sandwich Islands, have been secured by three parties. We may say, then, that the Delislean observations have been successful. Unfortunately, we gather that the photographic record of the interior contact is wanting. This, however, is of less value, as the Sandwich Island party, with an ingenious confusion of the subjective and objective, have already informed us that 'Janssen failed.'

"As in no case did the same observer secure both ingress and egress, the value of the observations for the application of the Halleyan method is doubtful; but the last reference—'Americans obtained some photographs'—may, when the work comes to be finally discussed, prove to be the most important of all, and astronomers all over the world will be very anxious to know the precise success attained, and it is very probable that it was great.

"Although we have thought well to wait for the news from Kerguelen before continuing our Notes, it must not be imagined that no intelligence of interest has been received since the last Notes appeared. On the contrary, the real interest is increasing as the details arrive; besides which, the French have received news from their parties at St. Paul's Island and Campbell Island, stations evidently outdoing even Kerguelen in the wretchedness entailed upon the observing parties, though that seems much to say after the report to the Admiralty which we published, yesterday;" while details of the observations at New Caledonia were given in last week's *NATURE* by one who took part in them. "At St. Paul's Island the observations have been most satisfactory, as both internal contacts were observed and numerous photographs were obtained. This is good news for the partisans of all three methods, ingress being greatly retarded here, as before stated. Unfortunately, the still more heroic occupation of Campbell Island has been without result. 'Venus seen before ingress only; no contacts; all well,'

is the news telegraphed from San Francisco, which must have cost M. Bouquet de la Grye a heavy pang to send home.

"We next come to the more detailed accounts, and among these, that forwarded by M. Janssen to the Secretary of the French Academy of Sciences demands the first place. After describing all the care he took in the choice of his station, he goes on:—

"Some days before the Transit, our fears were increased. Nevertheless, on the morning of the ninth the weather was pretty good, although the sky was a little overcast. The first contact was secured by M. Tisserand and myself. In the 8-inch equatorial, of which the object-glass is very good, the image of Venus appeared very round and well defined, and the relative motion of the disc of the planet with regard to the solar disc went on in a geometrical manner, without any appearance of ligament or black drop. But rather a long time elapsed between the moment at which the disc of Venus was tangent to the sun's limb internally and that of the appearance of the fine line of light between them. This anomaly I ascribe to the atmosphere of the planet. I caused a photograph to be taken at the instant the contact appeared to be geometric, and on the plate the contact had not yet taken place. M. d'Almeida obtained a plate containing forty-seven photographs of the solar limb which leads to the same conclusions. I intend to discuss these observations, which seem to me to lead to important consequences.

"After the first interior contact, M. Picard and M. Arens took as many photographs as possible, but the clouds greatly hindered us.

"Finally, near the second interior contact, the sun cleared as if provisionally, and M. Tisserand was able to determine the time with precision. The sky was perfectly covered at the time of last exterior contact.

"During the Transit even we got news from Kobé that the first two contacts had been observed, and that fifteen photographs had been taken, and, finally, shortly after our own observations, M. de la Croix announced that he had obtained the last two contacts, the last one only uncertain.

"He then concludes:—

"I must not conclude without referring to an observation which relates to the corona and the coronal atmosphere of the sun. With glasses of a certain violet-blue colour, and very pure, I was enabled to see Venus before she had touched the sun's disc. She was visible as a small, very pale, round spot. When she commenced to bite into the sun's disc, this spot completed the black segment which was visible on the sun. It was a partial eclipse of the coronal atmosphere. . . . I saw Venus two or three minutes of arc from the sun's limb.

"There are two points in Dr. Janssen's report of the greatest importance and interest. It seems not improbable that his observation of a geometric contact with the eye at the moment the contact was not complete to the photographic plate may be connected with Prof. Tacchini's observation with the spectroscope, to which we have referred in previous Notes. If the observation may be depended upon—and Janssen, it is not too much to say, is one of the best astronomical observers living—it is clear that the sun built up by the blue rays was smaller than the sun built up by the particular rays which in the telescope employed produced white light.

"The second point is the observation of Venus on the coronal atmosphere by means of violet glass. This attempt shows Janssen's genius in a remarkable manner. It is based upon the idea, derived from the eclipse work in 1871, that the coronal atmosphere is very rich in violet light, the idea in its turn being based upon the fact that the photographic corona is vastly different from the corona seen through a train of prisms. Of course, if this be so, the atmospheric light, which is not rich in violet rays, may be cut off by a glass of a dark-blue colour, which nevertheless will transmit the violet light coming from the corona, and so show Venus as a black spot.

"We condense the following details of the work done at the Australian stations from the *Melbourne Argus*:—

"At the Melbourne Observatory, presided over by Mr. R.L.J. Ellery, Government astronomer, the weather, by a happy chance,

cleared up in time for the observation of the important internal contact. The atmosphere was splendidly 'steady' in consequence of the previous fall of rain, and the effect of this was that the definition of the phenomenon was very distinct. There was no haziness or appearance of a 'black drop.' The contact was clear and tangential, and altogether free from the expected interferences with a good observation. During the contact and the following few moments, the photoheliograph was set to work, and numerous photographs of the ingress were obtained. They were taken rapidly at about two-second intervals, and about fifty were secured. The great telescope was used solely for photographing, in addition to the heliograph, but unfortunately it could not be brought into position quickly enough for photographs of the ingress to be taken by it, though it was used very effectively further on. The clouds then, as if they had just parted to allow of an observation at the critical moment, closed again over the sun, and its face remained obscured, with only occasional breaks; till between two and three o'clock. These breaks were availed of to obtain micrometric measures of the planet, which was now well on the sun's disc, and also to take photographs with the photoheliograph and the great telescope, which were very successfully obtained. Between two and three o'clock the weather began to clear up a little, and the observers were able to go more leisurely to work. The photographing went on well, though with several interruptions from passing clouds. The internal contact at egress, a very important point, was also observed very satisfactorily, although the atmosphere was a little more disturbed than during the internal contact at ingress, and there was observed a faint attempt at that appearance known as the 'black drop,' and a slight hazy ligament. For these reasons the internal contact at egress was not quite so satisfactorily observed as that at ingress, though a very good observation was made. During the egress a satisfactory series of micrometric measurements was made of the 'cusps,' and a rapid series of photographs was also obtained at two or three seconds' interval by means of the photoheliograph. The actual first internal contact was later than it was computed it would be by 3m. 13s. The first internal contact occurred at forty-five seconds after noon. The tabular time was 11h. 57m. 32s. The internal contact at egress occurred at 3h. 29m. 5s., or 1m. 31s. after the computed time, which was set down in the tables at 3h. 30m. 36s.

"Two hundred Janssen photographs were taken, and on development they were found to be as satisfactory as could have been expected, considering the frequent interruptions from clouds, and they will probably furnish some very important data. Besides these, thirty-seven photographs were taken with the great telescope and forty-seven with the photoheliograph. These were only taken when the sun was unobscured.

"Mr. Russell, the Government astronomer at Sydney, reports as follows:—'Very fine at Sydney, also Woodford and Goulburn, and, I believe, Eden (Tywofol Bay). I obtained a good many photographs. No black drop. Contacts not obtainable to a fraction of a second.' Mr. Russell also states that a beautiful halo was visible around Venus (indicating the atmosphere), before the planet was wholly on the sun. The Government parties have a total of 1,300 photos.

"The German party at the Auckland Islands have been heard of; from ten minutes after ingress the weather was very fine, and 150 photographs were taken.

"Mr. Ellery, in a paper read before the Royal Society of Melbourne, has given some information of great importance from a physical point of view, 'consisting of a compilation of all the observations of this nature which have been forwarded to him:—

"Mr. Anketell M. Henderson, observing with a Browning 8½-inch Newtonian, writes:—

"It cleared about 11.40, and I got my first observation. Definition perfect; not the slightest tremor. At 11.53 or thereabout I was surprised by seeing the surface of Venus, outside the sun, distinctly visible on a faint phosphorescent-looking background; it remained visible for about forty-five seconds, when clouds interfered.' Mr. C. Todd, of Adelaide, observing with an 8-inch refractor by Cooke and Son, remarked: 'For some time after internal contact at egress the portion of the planet which had moved off the sun was distinctly visible, appearing as though seen through a nebulous and luminous haze of a purplish hue, extending beyond and around the edge of the planet, and inclining to violet towards the sun.' He had received no other notes of the visibility of the disc of Venus outside the sun's disc

at egress, and he had been unable to get any trace of it himself, although the sky was clear and he looked for it. At Glenrowan the Transit was seen earlier than at Melbourne, and when the planet was about two-thirds on the sun Mr. Gilbert remarked, 'N.W. limb slightly luminous.' He then came to the appearance presented at internal contact, of which he noted as follows:—'This phase was remarkably well seen, and was almost tangential and free from any haze, ligament, or other disturbance. The sky remained clear in the neighbourhood of the sun till after internal contact was well over. About half-past two, before contact, limb of sun appeared to bulge out so as to embrace Venus, the outwardly bent cusps continuing around Venus like a thread of silver. Occasionally a slight flicker between the limb of Venus and sun visible, then a hazy junction like thin smoke appeared, and finally a very faint smoky thread appeared to join the thin edges.' This suddenly disappeared at oh. 1m. 9.48, Melbourne time.' Mr. White's observations gave almost similar results. At Mornington the late Prof. Wilson noted a 'stuffy connection,' which is undoubtedly the same phase already noted, viz., 'smoky connection.' At the final junction the sun's edge was very tremulous, but the sky was quite clear. Prof. Wilson stated of this phase that 'the sun's edge was boiling.' Venus did not look round, but as you might imagine a spherical balloon not quite blown up; the edge looked crumpled. A small dark object was seen flickering backwards and forwards between Venus and the edge of the sun. This increased, and there was no other phase to which I could attach a definite time.' At Sandhurst, Mr. Moerlin, observing with a 6½-inch refractor, remarked: 'As the planet moved gradually near the sun's limb at exit, the sun's limb and planet appeared sharp and well defined, and the streak of light between the two was distinct and unmistakable. As it came nearer and nearer the same appearance was witnessed without any change whatever. The streak of light became smaller, and all at once a sort of triangular-shaped connection between the two was observed, an appearance which I have seen with the artificial transit, but to a more limited extent, the base of the triangle on the sun's limb, the apex on the planet. The time when this phenomenon first appeared was 3h. 26m. 54.7s. The planet every once in a while jumped off the apex of the triangle, and the rim of the sun's disc could be distinctly seen between the two, the distance, however, between the triangle and the planet when jumping, growing less. The jumping or separating of the apex of the triangle and the planet ceased a few seconds before what I considered tangential contact.' Mr. Todd says, respecting this phase, that 'it was quite clear at egress, which was well observed; no black drop, but the continuity of the sun's disc was first broken by an exceedingly fine black line. The planet was seen to be slightly disturbed, the outline of the ball being apparently drawn out into a thin band.' With respect to an atmosphere surrounding Venus and the presence of a satellite, some of the observers had noticed towards the centre of Venus a light which condensed almost to a bright spot; and the Rev. Mr. Clarke, of Williamstown, observed a brownish orange halo surrounding Venus, and some others had observed a coloured light, though the difference of the tint was no doubt due to the eye-pieces used. He himself observed a blue light surrounding the planet, and made a careful scrutiny of it. He also called Mr. White and several others to observe, and they all saw it. He also noticed the granulated—or, as it was called, willow-leaved—appearance of the sun, which was very distinct, but approaching the planet presented a blurred appearance. With respect to the bright spot noticed in the centre of Venus, the same phenomenon was observed in the centre of Mercury during the transit of that planet.

"It has been suggested that all the observing parties at stations in or near Australia should meet about February in Melbourne, and compare their observations. Similar observations to those which have evidently attracted the attention of Mr. Ellery in a marked degree were perhaps made under the best possible conditions by Mr. Hennessey, at a height of between 7,000 and 8,000 feet in the Himalayas, and by other observers in India.' His observations have been communicated to the Royal Society, and will be found in NATURE, vol. xi. p. 318.

"We must wait for some time for the final determination of the sun's distance as determined by the Transit observations, but no time need be lost in fully discussing the various physical questions raised, in order that we may be fully prepared for the Transit of 1882."

## THE PROGRESS OF THE TELEGRAPH

I.

IN the present day scientific research makes such rapid progress, and produces such wonderful results, that the mind ceases to appreciate the advancement, which can only be realised by looking back, from time to time, to ascertain what was the condition of any special branch, any given number of years ago. It is only necessary to retrace time some twenty-five years, and in almost every department of practical science the step by step advancement may be traced, from sewing machines to steam hammers; from lucifer matches to lighthouses. But, perhaps, in no department of the applied sciences has scientific research been productive of more valuable and practical results than in the vast arena of electrical investigation; and great as has been the progress made in this department, still the knowledge obtained tends only to point out the vast field of research open to the student in discovering those fundamental laws and harmonies in nature's laboratory at present concealed from our view.

Sufficient, however, is already known in this special department of knowledge to inform us that electrical action and activity enters largely into the constitution of the solar system, regulating, in some degree at present not understood, the relation between the sun and our globe, as regards various terrestrial phenomena; as well as the disturbances upon the solar disc in relation to our earth's terrestrial and magnetic currents, as demonstrated in the daily deviations of the compass, and auroral displays in the regions adjacent to the polar latitudes of the earth. Thus we see that whatever may be the vast field of research that remains to the student in this branch of scientific investigation, most important results have been developed. Time has been almost annihilated, and in the race between the earth's revolution on its axis, and electrical speech, man's inventive genius has been victorious—time and space being so far distanced that in electrical transmissions from one part of the globe's surface to another, time has no value as measured by the earth's rotation; messages sent from India and the East arriving hours before the time of their despatch. The introduction of the electric telegraph is quite within the memory of the present generation. Up to 1844 electrical knowledge was more or less confined to the lecture-table; crude experiments upon frictional electricity and the elements of magnetic and voltaic phenomena constituted the portfolio of knowledge as accepted by the public. The profound researches of Oersted in 1819 in relation to the influence of a current of electricity upon the magnetic needle is of great importance and may be summarised as follows:—A magnetic needle poised on a pivot so as to move freely in a horizontal plane adjusts itself in what is termed the magnetic meridian. If a metallic wire is placed parallel to the needle at a little distance above it, and a

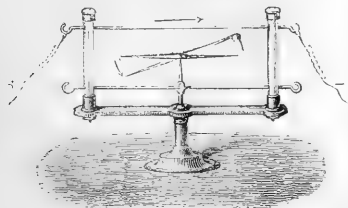

FIG. 1.—Action of an electrical current on the magnetic needle. (Oersted's experiment.)

current of electricity is passed through the wire, the magnetic needle will no longer remain parallel to the wire, but, leaving the magnetic meridian, will set itself across the current; and the same effect will be produced if the wire

is placed below the needle, and it will be found that if the direction of the current in passing through the wire is from S. to N., the north pole of the needle will be deflected in an opposite direction to where the current is passed from N. to S.; in other words, when the current passes horizontally *over* the needle, that pole which is nearest to the negative end of the battery always moves to the *west*, and when the current is passed under the needle the same pole will deviate to the east. Ampère in 1820, who employed the magnetic needle, the coil of wire, and the galvanic battery, to indicate signals, developed the principles of the discovery of Oersted, and demonstrated the fact that currents themselves exert an influence on other currents. From the importance of Ampère's experiments in relation to all telegraph apparatus, a few words clearly illustrating the action of the current upon the magnetic needle are necessary.

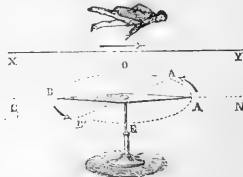

FIG. 2.—Deviation of the southern pole towards the left, under the influence of the upper current.

If the observer regards himself as the conductor or connecting wire placed parallel to the needle, and whose face in every position is turned towards the centre of the

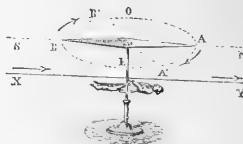

FIG. 3.—Deviation to the left of the current. Lower current.

needle, and the current from the positive pole of the battery to the negative pole is supposed to enter his feet and pass out at his head, the current will be found to develop a right and left influence on the magnetic needle, corresponding to the right and left of the person himself: so that *when an electric current acts on a magnetic needle, the south pole of the needle—which is that which is directed towards the north—is deviated towards the left*. Figs. 2 and 3 illustrate this: for when the parallel current is passed above the magnetic needle, the south pole A is deflected to A' to the left of the current, or towards the *west*; and on the current being passed below the needle, the same pole is deflected to A', being still to the left of the observer, but in this case the pole A has moved to the *east*. Ampère also demonstrated that when two metallic wires are traversed simultaneously by an electrical current, the wires are either attracted towards or repelled from each other according to the relative directions of the two currents. Thus, when they move in the same direction through the parallel wires, they attract each other, while they repel each other if they move in a contrary direction. Two non-parallel currents attract each other, if both are approaching or receding from the direction of the apex of the angle formed by the ends produced, while they will repel each other if one of the currents approach, and the other recedes from the apex of the angle. Fig. 4 illustrates the three cases of attraction and two cases of repulsion to which these laws of Ampère's refer. Ohm in 1827, who put forward his celebrated formulæ relating to the quantity of the galvanic

current; Faraday in 1831, who discovered the electric current induced in a hollow coil of wire when a steel permanent magnet or an electro-magnet is introduced or

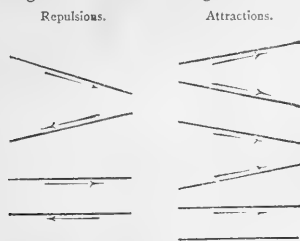

FIG. 4.—Law of the attraction and repulsion of a current by a current.

withdrawn from the coil; and Wheatstone, who in 1843 proposed to register observations of astronomical instruments with a view to determine longitude, and who shortly afterwards published, in the *Philosophical Transactions*, his investigations into the laws that regulate the transmission of electric currents through metallic conductors—were not then developed into any practical form; it was only about that time that public attention became directed to the probable future of the electric telegraph. The exhibition instruments open to the public at one shilling each, between Paddington and Slough, were the means of bringing to justice the perpetrator of a foul crime.



FIG. 5.—Induction by a magnet.

These early double-needle instruments, long since obsolete

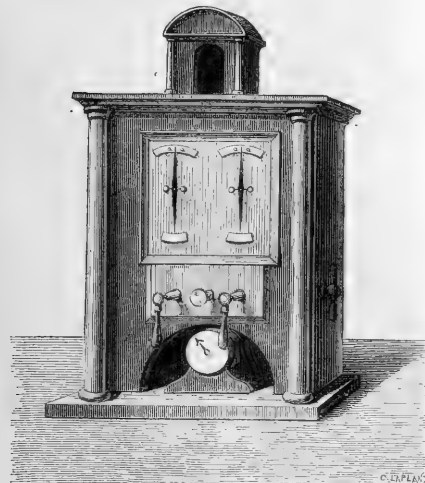

FIG. 6.—The Cook and Wheatstone double-needle Telegraph; 1845.

as regards construction, have been preserved as indicating his first era in telegraphic communication.

In those days electrical knowledge was in its infancy: the very wire between Paddington and Slough was insulated partly by silk and suspended through goose-quills attached to the posts along the Great Western Railway. In those days of electrical innocence the practical value of the return-circuit by means of the earth was undeveloped. As early as 1840 Wheatstone first conceived the idea and published his plans for transmitting messages under the sea by means of a submarine cable. That scientific men at that time considered that such a discovery would lead to most important results is testified to by the Abbé Moigno, who writes that it was announced by Wheatstone in 1840 that he had found the means of transmitting signals between England and France, notwithstanding the obstacles of the sea; and he emphatically adds: "I have touched with my hands the conducting wire which, buried in the depths of the ocean, will unite instantaneously the shores of England with the shores of France." In 1844, at Swansea Bay, off the Mumbles Lighthouse, the first practical experiment took place, and signals were transmitted from an open boat to the shore from a considerable distance. In the boat sat the inventor, Wheatstone, his eyes eagerly watching his galvanometer for the coveted signals—signals that would tell him his hopes were realised, and

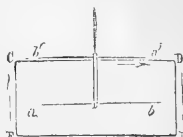

FIG. 7.—System of two magnetic needles, with their poles reversed, forming an astatic combination, neutralising the effects of terrestrial magnetism.

—signals that would tell him his hopes were realised, and

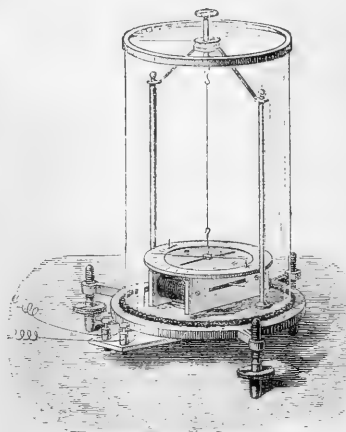

FIG. 8.—Astatic Galvanometer.

that he had triumphed over the elements. The last twenty-eight years have given birth to many wonderful and practical results. Between 1844 and 1848 railways were in their infancy; their limit of distance as compared with their present extent was very circumscribed. Equally so was electrical knowledge, as compared with the requirements of extended distance. In 1848 Holmes gave to telegraphy the practical result of his researches as regards the rapid transmission of signals over extended circuits. In those early days the five-inch astatic needles and coils of the Cook and Wheatstone system were absolutely useless for longer distances than one hundred miles, and as railways extended, so telegraphic difficulties were

found to multiply. The introduction of gutta-percha in 1850 and a more perfect knowledge in the preparation of indiarubber as insulating mediums for electrical purposes have been the means of establishing upon a commercial basis electric communication between the chief empires of the earth, have united the eastern and western hemispheres by metallic highways of thought, threading the trackless ocean with its mysterious depths. It is thus that the primitive experiment of Wheatstone in 1844 has developed into the stupendous telegraphic undertakings that encircle the globe, uniting with a common interest all nations, creeds, and languages.

The principal laws that regulate the transmission of electric currents through metallic conductors are simple, and may be briefly described with sufficient distinctness to enable the general reader to grasp the intricacy and magnitude of the science of electric transmissions.

Leaving on one side the old accepted terms of conductors and non-conductors, for the present purpose all substances in nature must be regarded as able more or less to conduct a current of electricity.

As the various substances, gums, glass, wood, carths, liquids, or metals are examined, it will be found that some afford much greater facility for the transmission of electricity than others; consequently, if they are arranged according to the resistance offered to the current, a list somewhat similar to the annexed will be presented, commencing with those of least resistance: copper, iron, plumbago, sea-water, rain-water, snow, steam, moist earth, oils, ice, phosphorus, porcelain, baked wood, dry paper, hair, silk, mica, glass, wax, sulphur, shellac, gutta-percha, india-rubber. It therefore naturally follows that where it is required to construct a system of submarine circuits for the conveyance of electric currents from one place to another, some metal, such as copper, is selected. Water being also pretty high in the scale, it is essential that to prevent leakage or loss of current in its passage through the wire, a gum such as gutta-percha or india-rubber, offering a high resistance, should be selected in which to enclose the conducting wire and give proper insulation to the circuit. It is therefore evident that the perfection or freedom from loss or leakage in an electric circuit is simply relative as regards the material employed, and insulation means the obstruction or resistance placed in the way to prevent the escape of electricity from the conducting wire. Various important phenomena come into play in connection with the passage of an electric current through an insulated circuit, which it is necessary to explain in an elementary manner. Induction, or the production of an electric current moving in an opposite direction to that of the current passing through the insulated conductor, takes place in the adjacent medium to that of the insulated wire; that is to say, supposing an insulated metallic circuit—a submarine cable—is fulfilling its duties in the transmission of an electric current throughout the metallic conductor, the effect of that current will be to set up a second current in the water moving in an opposite direction. This opposite or induced current is well illustrated by the Leyden jar familiar to everyone. The inside metallic foil represents the copper wire, the glass separating the foils the insulation of the cable, the external metallic coating the water surrounding the cable. On electrifying the Leyden jar the internal and external metallic coats become charged with electricity in opposite states. The effect of this induced current on submarine cables is to retard or pull back the flow of the primary current, sensibly diminishing the speed of transmission as compared with that of a land line of telegraph. On a land line with a single wire the effect of induction does not take place, because the metallic conductor, generally iron, requires no insulating medium to enclose it, the air itself taking the place of the insulator; the wire requires to be insulated only

at the points of support, the tendency of these being to produce a leakage or weakening of the current from water and other substances held in suspension in the air, impairing the integrity of the contacts at the points of suspension. Induction, however, takes place with land wires under certain conditions, namely, when two or more are suspended closely together; a current through one wire will then produce an induced current in an opposite direction in an adjacent wire. Induction increases with the extent of surfaces of the copper conductor and the insulator with which it is covered diminishing the speed of transmission.

Insulation may be obtained by a very thin covering of the insulating medium. Increase in the thickness of the material only mechanically renders the covering more secure. The effects of induction are decreased in proportion as the insulating substance is increased in thickness, the conducting wire remaining the same; with an infinite insulation like the atmosphere, induction would cease.

With insulated wires, absorption (inductive capacity) takes place. No substance in nature has yet been found that will not absorb some other element, force, or matter in a greater or less degree. Heat, light and electricity, liquids, gases, and metals under varied conditions are all alike susceptible, and will either be influenced or retain in different proportions the various elements, forces, or matters brought into juxtaposition with them. At present it is only necessary to investigate the phenomenon of electrical absorption or inductive capacity. Thus, when a current of electricity passes through an insulated metallic circuit, certain known effects take place. Resistance, which impedes the direct progress of the current; induction, or the setting up of a counter-current moving in an opposite direction, and exerting, as it were, a pulling back of the original current; absorption, or the sucking up into the substance of the insulating material of a sensible integrant of the original current. Various insulating gums, as gutta-percha and indiarubber, have different properties as regards the insulation or resistance to the lateral escape of the electric current they enclose, namely, the inductive effect in proportion to the insulation, and the absorption of the current as it flows through the conducting wire enclosed by them. As a sponge sucks up water, so to a certain extent does the insulator of the submarine wire absorb the electric current, the result being that, instead of the current passed into the wire at one end flowing through and emptying itself out at the other end of the wire, the current will flow out and leave a residue behind, an appreciable time being required for discharge to clear the line. This absorption of the current leaves the line clogged for the receipt of the next current, and greatly interferes with the rapid transmission of currents through insulated metallic circuits. It is therefore only in short cables that the transmission of the current may be considered instantaneous. In cables exceeding 150 miles in length, electric currents have a sensible duration.

(To be continued.)



FIG. 9.—Charging the Leyden jar.



ON SOME REMARKABLE CHANGES PRODUCED IN IRON AND STEEL BY THE ACTION OF HYDROGEN AND ACIDS

FOR a long time it has been well known to wire-drawers and other manufacturers, who free the iron or steel they are engaged in working from rust by cleaning it with sulphuric acid, that after this process the metal becomes much more brittle than before. Further, if a piece of iron wire that has been cleaned in sulphuric acid be bent rapidly to and fro till it is broken, and the fracture be then moistened with the tongue, bubbles of gas arise from it, causing it to froth. If this same wire be now gently heated for a few hours, or left in a dry warm room for some days, it will be found to have regained its original toughness, and not to be froth when broken and the fracture moistened.

Some experiments made by the writer on this subject during the last three years, have shown that not only sulphuric, but hydrochloric, acetic, and other acids which give off hydrogen by their action on iron, produce the same effect, making it probable that hydrogen is the cause of the change. This view is confirmed by collecting the gas given off at the surface of the iron and burning it, when the characteristic flame of hydrogen is seen.

Putting the facts together, it seems probable that a portion of the hydrogen generated by the action of the acid on the surface of the iron is occluded and subsequently given off, either rapidly, as when the iron is heated by the effort of breaking it causing the water on the surface of fracture to bubble, or, more slowly, in the cold.

Perhaps the simplest way of charging a piece of iron with hydrogen is by laying it on a sheet of zinc in a basin of dilute sulphuric acid. An electric current is here set up, and the hydrogen generated by the action of the acid on the zinc is given off at the surface of the iron. In this way two minutes or even less will often suffice to charge a piece of iron with hydrogen and alter its properties as completely as one hour's immersion in dilute acid without the zinc.

The change in the properties of iron which has occluded hydrogen is not confined to a diminution of toughness, though this may be reduced to one-fourth, but is accompanied by a remarkable decrease in tensile strain, amounting in cast steel to upwards of twenty per cent. after twelve hours' immersion in sulphuric acid. With iron wire the decrease in tensile strain was found to be less than with steel; the reduction amounted however in some cases to six per cent. Some interesting differences are noticeable in the relative effect of occluded hydrogen on mild steel and highly carbonised steel, the diminution of tensile strain after occlusion of hydrogen being greater in the latter case than in the former.

As with the metal paladium, so with iron, the electrical resistance is increased somewhat by occlusion of hydrogen; in fact, it seems probable that every property of iron or steel undergoes a change after the occlusion of hydrogen, and the extent of this change becomes a matter of great interest to the engineer now that iron and steel are so largely used.

Cases of the deterioration in toughness of iron of excellent quality exposed to the action of gas containing acid, as in the upcast shaft of a coal-pit, have come before the writer's notice, in which the change appeared to have resulted more from hydrogen occluded by the iron than its corrosion by the acid vapours. It is also probable that rapidly rusting iron occludes hydrogen, and is thereby weakened in strength and toughness.

WILLIAM H. JOHNSON

THE SOUTHPORT AQUARIUM

THE grounds of the Southport Pavilion, Winter Gardens, and Aquarium Company occupy an area of about nine acres, extending from a portion of the sea-wall and

parade, on which they have a frontage of 1,100 feet, to Lord Street, the chief thoroughfare of the town, which runs in a straight line, roughly parallel to the sea-coast, for nearly a mile.

Entering the pile of buildings, which occupy about the centre of the grounds, by the chief portico on the Lord Street side, and ascending a wide flight of steps, the Promenade Hall is reached, which is constructed of pitch pine, and is over the principal corridor of the aquarium, to which access is obtained by descending a flight of steps, or an incline, placed on either side of the staircase leading up to the hall, which, like the corridor beneath it, is 160 feet in length by 42. To the right of the hall, and separated from it by glass doors, is the Band Pavilion, which is said to be capable of holding 2,000 people; round it is a gallery used as a promenade, and in which pictures are exhibited, and beneath it is the refreshment department, which is on the basement level. Likethe aquarium,\* the Pavilion is oval in shape, the longest axis being 136 feet, the shortest 76. To the left of the great hall, glass doors give admittance to a glass conservatory, 174 feet in length by 74, stocked with tropical and subtropical plants and birds; beneath it are the remaining corridors of the aquarium.

The first corridor of the aquarium contains twenty-three tanks, the front of each consisting of three sheets of plate glass, as at Brighton; and the light, as there, is all transmitted either through the water in the tanks or through plates of opaque glass placed in the floor above. The roof consists of double groined arches, supported on moulded columns, made of concrete, which has been largely used in various parts of the building with good results.

Tanks 1 to 23 contain: Sea Anemones, Nos. 7 and 23; Octopi, 11 and 21; Crabs, Spiny and Common Lobsters, 10, 16, 19, and 22; four specimens of King Crabs, 20; Conger and Common Eels; Salmon Trout; Ballan Wrasse, 6; Rough Hound and other dog-fish; Cod and Rock Cod; Grey, Streaked, and other Gurnards; Whiting, Soles, Plaice, Bret, &c.; Father Lasher (*Cottus scorpeus*), 4; two specimens of the Angel or Monk Fish, 15.

By the side of the tanks, plates of fishes from Yarrell's work are hung, which, not always having any connection with the living fish exhibited, rather distract attention, and would be better collected together with various stuffed fish placed at the top of the tanks, and placed in a small museum. Amongst the plates are some original coloured drawings of Mr. Jonathan Couch, of seven species of sharks, signed "J. C., 1825"; also eight drawings of flying-fish, by the same.

Corridor No. 2 has a flat ceiling supported on iron columns, is lighted by windows looking on to the garden on the Lord Street side, and contains table tanks, rectangular and octagonal, the former being filled with fresh water, the latter with salt, containing, amongst other things, several species of *Serpula*, *Sabella*, *Terebella*, *Amphritrite*, *Aphrodita aculeata*, and other annelids; Sea Anemones of various species; *Thyone papillosa*, and other *Holothuriadae*; *Ascidia* and other tunicated molluscs; various species of Starfish, *Cidaris*; Norwegian Lobsters; Blennys, fifteen and three spined Sticklebacks, and large numbers of living zoophytes. Several of these tanks, both in the beauty of their varied contents and the care with which they have been selected and arranged, afford a good example of what can be done by art to reproduce a portion of the richness of effect of the actual sea-bottom.

On the right or seaward end of this corridor there is a Seal Tank, five seals living in it and in the Seal Pond in the garden between the entrance lodges and the portico of the Promenade Hall. On the opposite end of the corri-

\* The ground slopes from the sea towards Lord Street, so that the aquarium is underground on the seaward side. In my "Notes on the Geology of Liverpool," NATURE, vol. ii. p. 399, I have described the sand dunes, &c., of this coast.

dor is a very large tank (24), containing a large number of freshwater fish given by Mr. T. R. Sachs, of the Thames Angling Preservation Society. In tank 25 are Sea Perch; and in tank 27, which occupies the entire side of corridor No. 3, being no less than 63 feet in length by 14 feet in width, with seven feet of water, are a large number of full-sized dog-fish, a perfect shoal of large cod, and a Monk Fish more than five feet in length.

The aquarium in this direction is capable of almost indefinite extension, should the present success of the Company be maintained.

The sea-water for the aquarium is obtained from the Baths Company, who draw their supply from a point in the channel near the end of the pier, which is more than 1,400 yards in length. The water is received in a large storage tank under the conservatory, from which it travels through the various tanks, returning to a lower storage reservoir, from which it can be pumped back into the upper one, not less than 150,000 gallons of water being in constant circulation. As at Berlin and Brighton, compressed air is forced into the tanks, through india-rubber pipes; and Mr. Lloyd's plan of putting oysters into the tanks, introduced at Brighton, is adopted. The tanks, as well as the rest of the building, including the conservatory, are lighted at night by gas.

In the existence of large aquariums at Southport and Brighton, the ideas so long advocated by Messrs. Carl Vogt, Milne-Edwards, and Dr. Anton Dohrn, for the establishment of zoological stations, have to a certain extent been realised in England; but before they can be made available for original observation and research, laboratories must be built, and depot stations established at a few points on the coasts of Ireland and Scotland. Moreover, other large expenditures of an eminently uncommercial character must be incurred, which will never be entertained by commercial companies; but these, on the other hand, would probably not object to afford facilities for study if the necessary funds were found by those colleges, universities, and learned societies that prosecute the study of biological science.

CHARLES E. DE RANCE

### NOTES

THE Eclipse Expedition arrived safely at Point de Galle on March 15. The Indian observing party proceeds to Nicobar Island by the *Enterprise*, which left Calcutta on the 11th inst.

As we have already intimated, the Faraday Lecture of the Chemical Society will be given to-night in the Theatre of the Royal Institution by Dr. Hofmann, of Berlin, on "Liebig's Contributions to Experimental Chemistry."

THE service of meteorological telegrams to the ports of France was resumed on the 1st inst. The arrangements now in operation are as follows:—A large placard is sent down to be posted up in some public place, containing two specimen daily charts of the weather, and some simple rules for interpreting them. There are three blank spaces at the foot of the placard, which are intended for the chart of the preceding day from the *Bulletin International*, which arrives by post, and for two forecasts, morning and evening, which are to be transmitted by telegraph daily. It does not appear that there is to be any provision for exhibiting signals for the purpose of giving warning of storms. At present the only such signals which are apparently in use on the French coasts are those hoisted by the authorities of the Marine Ministry, from Dunkirk to Nantes, on the receipt of warning telegrams from London, and those hoisted south of Nantes, on the coast of the Bay of Biscay, on the receipt of orders from the *Préfet Maritime* of Rochefort.

THE French Telegraphic Administration has appointed two delegates to examine, in common with the Board of the Observatory, what steps should be taken to collect by wire meteor-

ological information, in order to send warnings to agricultural districts. The organisation of agricultural warnings will be one of the principal subjects of discussion at the forthcoming Paris Meteorological Congress.

M. MOUCHEZ, the chief of the St. Paul French Transit party, gave before the Academy of Sciences of Paris, at its sitting of the 15th inst., the first part of his report. M. Velin, the naturalist of the expedition, brought with him to Paris three living and a number of preserved specimens of all the species of the existing fauna, which is almost entirely marine. No landing could be effected on Amsterdam Island. Saint Paul and Amsterdam cannot be regarded as the remains of a shattered continent, but from their appearance and geological connection must have been elevated from the bottom of the ocean by individual volcanic eruptions.

We learn from the *Saar und Mosel Zeitung* that we are liable to the importation not only of potato-beetles and Phylloxera, but even shells. About fifteen years ago some small shells were discovered in the Moselle near Treves, which were very different in form from the other native species. A few weeks back the discovery was made that the same locality now abounds in this new animal, as large numbers were found in a perfectly developed state. This seems to prove that the little ones, that were doubtless imported by some raft, have grown and propagated. It is stated that the real home of this species is the Sea of Azoff and the Black Sea, and it is remarkable that they inhabit both salt and fresh water.

THE *Kölnische Zeitung* reports that besides Phylloxera and the Colorado Beetle a third noxious insect has come over to Europe from America; it is the so-called Blood Louse, which causes much damage to apple-trees. As a practical remedy against this unwelcome guest, it is recommended to paint the young trees with naphtha and lime-water. With arger trees of course this is impossible; but it is said that if during winter a thin lime paste is placed in a circle round the tree where it comes out of the ground, the ova of the Blood Louse are then completely destroyed.

THE discovery is announced at the Pola Marine Observatory of Planet 143, by Director J. Palisa, with a telescope of 7½ ft. focal length. It appeared on the 12th magnitude, and the ephemerides given are: 1875, Feb. 23, 8h. 42m. 12s. Pola mean time; R.A., 9h. 57m. 57s. (daily motion - 60s.) and Decl. + 13° 46' (daily motion + 1'). Of the 143 asteroids, 97 have been discovered in Europe, 41 in America, and 5 in Asia.

THE celebrated physicist Amberg lately delivered three lectures at the "Volksbildungsverein" at Cologne, principally on the phenomena of Electricity, Optics, and Acoustics.

THERE will be an election at Magdalen College, Oxford, in June next, to at least one Demysip and to one Exhibition in Natural Science. The stipend of the Demysip is 95*l.* per annum, and of the Exhibition 75*l.*, inclusive of all allowances, and they are tenable for five years. Particulars may be obtained by applying to the senior tutor.

THE Council of the Senate of Cambridge University propose to offer a grace early next term for the appointment of a syndicate to consider the propriety of establishing a professorship of Mechanism and Engineering.

AMONG the papers appointed by the Council of the Institution of Naval Architects to be read at the meetings on the 18th, 19th, and 20th inst., are the following:—On the Telegraph ship *Faraday*, by W. C. Merrifield, F.R.S.; On a mode of obtaining the outlines of sea-waves in deep water, by W. W. Rundell; On the graphic integration of the equation of a ship's rolling, including the effect of resistance, by W. Froude, F.R.S., vice-president; On a method of obtaining motive

power from wave motion, by B. Tower; Notes on polar diagrams of stability, &c., by John McFarlane Gray; On compound engines, by R. Sennett; On the *Bessemer* steamship, by E. J. Reed, C.B., M.P., vice-president.

M. WALLON, the new French Minister of Public Instruction, is an old University man; he was for years Professor of History in the Normal School. His appointment has given great satisfaction to the French *savants*, and the reception which he had on his installation on the 13th inst. was something more than a formal congratulation.

AN interesting study has lately been made by Prof. Holden, of the Washington Observatory, on the observations of Sir William Herschel upon the satellites of Uranus. It is well known that the latter astronomer sixty years ago announced that Uranus was accompanied by six satellites; but of the existence of four of these there has always been considerable doubt, since no one was ever able to confirm the observations of Herschel. In 1847 Lassell discovered two interior satellites, which were, however, different from those which Herschel suspected; and since that day the four problematical satellites of Herschel have been generally discarded by astronomers. Prof. Holden now brings testimony to the high excellence of Herschel's observations, as, by computing backward, he has shown that probably this distinguished astronomer actually observed the two interior satellites of Lassell (named by him Ariel and Umbriel); but that he was unfortunately prevented from identifying them as satellites because his telescope could not show them on two successive nights. The extreme difficulty of observing these objects makes us wonder at the marvellous skill and patience manifested by the elder Herschel in this laborious research, which was carried on by him from 1787 to 1810.

THE Imperial Astronomical Observatory of Brazil is a dependence of the Central College of Rio Janeiro, and is destined not only to teach practical astronomy to the students, but to make and publish astronomical and meteorological observations. The chronometers of the navy and army are there regulated, and the time is given daily by signal to the city. The building is situated on an eminence within the city, and the Government is now taking measures to improve its scientific character. The director is at present in Europe with a view of procuring such instruments and apparatus as may be adapted to the studies required of the institution. An entire reorganisation of the Observatory is under way, with the purpose of training more thoroughly the persons charged with geologic and geodetic works. There is also an observatory at the capital of the province of Pernambuco.

We have received the Catalogue of the Library of the Manchester Geological Society, compiled by Mr. John Plant, F.G.S. We are glad to see that the members of this Society possess so good a collection of works connected with the various departments of geology, and we hope a large proportion of them take advantage of the privilege. Mr. Plant has arranged the books in eleven divisions, which will no doubt facilitate the work of reference, though it seems to us that divisions for works in German, works in French, &c., are unnecessary.

MR. HENRY CHICHESTER HART, B.A., one of the naturalists appointed to the Arctic Expedition of 1875, has published an enumeration of all the flowering plants and ferns known to occur in the Arran Islands, Galway Bay. The flora of the whole of the west of Ireland is extremely interesting on account of the south-west European types it includes, indicating the possible former existence of a connection between the British Islands and the Continent. The Arran Isles flora includes no endemic species, and, on account of their peculiar geological formation, the number of species is scarcely so large as might otherwise have

been expected. The formation belongs to the Upper Carboniferous Limestone, and consists of deeply-fissured platforms or terraces, paved with large flags. Mr. Hart's list contains 372 species, including *Dabocia polifolia* and some other West European forms. *Ajuga pyramidalis* and *Helianthemum canum* are at home here, and *Gentiana verna* is reported to be one of the commonest weeds. One of the principal features of the flora is the luxuriance of the ferns in the deep fissures of the rocks. The true maiden-hair (*Adiantum capillus-veneris*) is said to be common on all three islands, and often found with fronds two feet long. In the same situations the fronds of *Asplenium marinum* attain a length of three feet, and those of *Ceterach officinarum* a foot or more. Mr. Hart himself adds about twenty-five undoubtedly indigenous species to those previously known.

WITH regard to the conservancy and working of the East Indian rubber-trees (*Ficus elastica*), the yield of which forms one of the most important products of the Assam forests, we learn that there have been three proposals made to Government: the first is that Government should annually sell the right to collect the rubber; the second, that the rubber should all be purchased by Government; and the third, that Government officers should manage the forests. In opposition to this, however, it is said that much of the rubber is brought in from forests by wild and half-subjugated tribes, and still more by tribes that are under no subjection at all; so that conservancy is impossible, and a Government monopoly very difficult. Only two courses seem possible: either to allow speculators to make their own bargains with the hill men as they liked, or to enforce an effective Government control. Sir George Campbell considers the latter course to be the right one. The exports of caoutchouc, it appears, which amounted to 21,000 maunds in 1871-72, fell in 1872-73 to 11,000, this decrease being attributed to the closing of the Luckimpur forests with a view to preventing frontier complications.

THE quantity of sandal-wood sold in the provinces of Mysore and Curg during the year 1872-73 was \$89 tons, valued at 27,896*l*.

THE growth of beet-root in Belgium for the manufacture of sugar appears to be falling off, owing to its prohibition by landowners and the unwillingness of the farmers to cultivate it in consequence of its exhaustive nature, a crop of beet impoverishing the soil considerably. It is said, however, that if the farmers could act independently, considerable quantities of beet would be grown, for not only would it then be advantageous to them in a pecuniary point of view, but it would furnish them with a new and valuable food for the use of their cattle and horses. In France, on the other hand, the cultivation of beet is being extended, the pulp, after the extraction of the sugar, proving very serviceable for fattening cattle.

DR. R. A. PRYOR intends publishing a new "Flora" of Hertfordshire, and to enable him to make it as complete as possible, he has issued a circular containing lists of plants respecting which further information is needed. Critical species will be thoroughly studied out. Webb and Coleman's "Flora Hertfordiensis" (1849), supplements to which appeared in 1851 and 1859, is a very good work, and the only "Flora" of the county hitherto published; but so much has been done in critical botany of late that it is, in this respect, out of date.

ON Friday the 12th inst. an icy cloud passing before the sun exhibited the laws of the formation of halos with an extraordinary precision. The cloud, driven by an upper wind, was travelling at a slow rate from south to north. A partial halo was first seen on the northern edge, developed itself, lasted as long as the cloud, occupied more than 16½° north and 16½° south

of the sun, and diminished gradually until it disappeared on the southern edge of the cloud. It was, when complete, a perfect circle of white light, with the centre quite black, but not thick enough to prevent the sun being seen. The phenomenon lasted from 11:39 to 12:15, and was noticed at the Paris Observatory.

AMERICAN papers state that an earthquake at Guadalajara, Mexico, on the 11th of February, damaged houses and churches. The Seboruco volcano at the same time was in a violent state of eruption. The shocks extended to San Cristobal, where houses were destroyed, and several persons were killed.

FOR the protection of vineyards against frost in spring, the production of large artificial clouds of smoke is a common appliance in France and Germany. We now hear of a new method in this operation, recommended by M. G. Vinard. It is easily executed, and has proved successful; it consists in carefully mixing gas-tar with sawdust and old straw, and piling up this mixture into large heaps in the vineyards. The mixture remains easily inflammable, in spite of rain and weather, for more than a fortnight. When required for use, smaller heaps are made from the large ones, of about two feet in diameter, and are distributed in and round the vineyard. If there is little wind these heaps burn freely for about three-and-a-half hours, and produce a very dense smoke. The artificial cloud which thus envelops the vines considerably decreases the radiation from the ground, and with it counteracts frost, which is greatest towards morning during calm spring nights, and which does so much harm to the plants.

It is proposed—in fact steps have been taken—to acclimatise the Florida Cedar in Bavaria. The superiority of the wood of this tree (*Juniperis Virginiana*) over all other kinds of cedar, is well known, and the demand for the wood in Bavaria, where immense quantities of lead-pencils are made, has induced some manufacturers to take up the question of the acclimatisation of the tree in that country. Seeds have been sown in the Royal Forest, and about 5,000 young plants have been grown on one private estate: the cultivation of the tree is also being attempted in other parts of Germany.

IN a farm in the State of Nevada (U.S.), near the River Larson, there is a troop of twenty-six camels, all of which, with the exception of two, have been reared there. A few years ago nine or ten of these animals were imported into America, but only two survived; and these two, being fortunately a male and female, have produced twenty-four, all of which are now alive. The soil is sandy and sterile in the extreme, and the animals thrive well, although their only food consists of the prickly leaves of a small shrub, and bitter herbs which cattle will not touch. They are employed to carry merchandise, and perform considerable journeys across a very barren country.

A RECENT number of the *Courrier* of Jonzac reports that a meteorite was seen falling on a field in the Island of Oleron, and is believed to be a part of the meteor which was seen at so many places on the 10th of February last. The circumstances of the fall will be investigated carefully.

A METEOR was not only seen but actually caught at Orleans on the 9th inst. A small mass of pyritous substance was discovered in one of the streets, at the very place which had been struck by an immense flame a few seconds before. The pieces were divided among bystanders anxious to secure the possession of the smallest fragment of such a celestial object; but it is hoped some of the possessors will be intelligent enough to get a specimen sent to the Academy of Sciences.

ASTRONOMICAL and meteorological subjects are beginning to interest the French public. Two of the most influential Parisian papers, the *Temps* and the *Sidre*, publish daily, with comments, the weather forecasts of the Observatory.

WE may expect soon to see every large town in the kingdom in possession of an aquarium. A very fine one has quite recently been completed at Southport, a description of which we are able to give in to-day's NATURE; the foundation-stone of the Westminster establishment will be laid in a week or two; a scheme for the construction of an aquarium at Plymouth is maturing; an aquarium and winter garden is talked of at Edinburgh; a bill is before Parliament for the purchase of a site at Scarborough for an aquarium; and we have every reason to hope that Birmingham will soon be able to count one among its many other educational institutions. In a recent lecture at the last-mentioned town by Mr. W. R. Hughes, F.L.S., on Aquaria, the lecturer pointed out very forcibly how valuable such institutions might be made as a means of education. That gentleman deserves great credit for the trouble he has taken to obtain full information concerning the history and management of aquaria, and under his guidance we should think an aquarium at Birmingham ought to be second to none in the kingdom.

WE are glad to see from several numbers of the *Huddersfield Chronicle* which have been sent us, that the Huddersfield Naturalists' Society is in a healthy working condition. The members are evidently successfully investigating the natural history of their district, and from the reports of papers read and the discussions thereon, we judge that a considerable proportion of the members take a share in the business of the Society.

THE additions to the Zoological Society's Gardens during the past week include two Vervet Monkeys (*Cercopithecus talandii*) from South Africa, presented by Mrs. A. Thornley; a Macaque Monkey (*Macacus cynomolgus*) from India, presented by Mr. H. Edwards; a Chimpanzee (*Troglodytes niger*) from West Africa; two Indian Muntjacs (*Cervulus muntjac*) from India, deposited; a Yellow-bellied Liothrix (*Liothrix luteus*) from India, purchased; two Hairy Armadillos (*Dasyurus villosus*), born in the Gardens.

#### SCIENTIFIC REPORT OF THE AUSTRO-HUNGARIAN NORTH POLAR EXPEDITION OF 1872-74 \*

##### II.

MAGNETIC disturbances are closely connected with the Auroræ; while in temperate zones they are the exception, they form the rule in Arctic regions, at least the instruments are almost in constant action. This is the case for the inclination, declination, and intensity needles. As long as the vessel was drifting, *i.e.* until October 1873, the fixed variation instruments could not be used; absolute determinations with Lamont's magnetic theodolite were made, and several "magnetic journals" (only declination-readings) were kept, but already when near Nowaja Semlja, Lieut. Weyprecht found out that on account of the constant disturbances these readings were of very little value, as they could not be compared with simultaneous readings of the variation-instruments. In November, as soon as it was ascertained that the ice-field which enclosed the ship had come to a standstill, Lieut. Weyprecht had snow-huts constructed in which he fixed the variation-instruments, the magnetic theodolite, the inclinometer for the absolute determinations, and the astronomical instruments. The three variation-instruments for declination, horizontal intensity, and inclination had been furnished to the expedition by Prof. Lamont, director of the Munich Observatory.

After one day's work it was found already that the former methods of observation, *i.e.* simple readings at certain hours, are of no value whatever in Arctic regions, as they represent solely the accidental magnitude of the momentary disturbance. These neither give any true mean result, nor do they correctly represent the action of the needles. All intervals, which were observed for such readings at former expeditions, are absolutely useless, lying far too widely apart to permit of correct conclu-

\* Die 2. Oesterr.-Ungarische Nord Polar Expedition, unter Weyprecht und Payer, 1872-74. (Petermann's Geogr. Mittheilungen, 1875; heft ii.) (Continued from p. 363.)

sions as to the general magnetic conditions. Under these circumstances Lieut. Weyprecht resolved to proceed very differently: upon every third day he let observations be made every four hours all the day long, and had the readings taken for every minute during one whole hour at a time; on each day different hours were chosen for the readings. Besides this, in order to get an idea as to the whole daily course, he made observations every five minutes during twenty-four hours, twice a month. With a view to make all observations as simultaneous as possible, the readings were taken immediately after one another (generally within eight to ten seconds), the telescopes of the three instruments being all fixed upon the same axis. These observations were continued from the beginning of January to the end of April 1874, comprising altogether thirty-two days of observation; Lieut. Weyprecht believes that when tabulated, their results will give a true representation of the unceasing changes with regard to direction and intensity of magnetic force in Arctic regions. In order to confirm the connection between the aurora and the action of the needles, a second observer, independently of the others, observed the changes and motion of the aurora. Absolute determinations of the three constants were made as often as circumstances permitted, to control the variation-instruments.

Apart from the Swedish Expedition, whose observations are not yet published, Lieut. Weyprecht points out that his are the first regular and simultaneous observations that were ever made in the Arctic districts. Moreover, he thinks that all former observations were made with the ordinary heavy needles, and that he was the first to use the light Lamont needles. For observations, however, under such conditions as the normal ones near the pole prove to be, heavy needles are perfectly useless; even the comparatively light intensity-needle of Lamont's theodolite oscillated so violently, on account of its unproportionally great moment of inertia, and even with moderate disturbances, that the readings became quite illusory. Almost on each magnetic day some disturbances were so great that the image of the scales could no longer be brought into the field of the telescopes on account of deflection; in order to ascertain even these maximal phenomena, Lieut. Weyprecht constructed an apparatus by which he could at least measure them approximately. He owns that as a matter of course his observations could not possibly be as perfect as those made at home, but thinks that it will be easy to modify Lamont's instruments on the basis of his experiences, so that with a future expedition, where there is a greater staff of observers, results could be obtained of any desired exactness. Altogether Lieut. Weyprecht's party of observers, consisting besides himself only of Lieut. Brosch and Ensign Orel, have taken about 30,000 readings from their different magnetic instruments, and the principal results are the following:—

The magnetic disturbances in the district visited are of extraordinary frequency and magnitude. They are closely connected with the Aurora Borealis, the disturbances being the greater, the quicker and the more convulsive the motion of the rays of the aurora, and the more intense the prismatic colours. Quiet and regular arcs, without motion of light or radiation, exercise almost no influence upon the needles. With all disturbances the declination needle moved towards the east, and the horizontal intensity decreased, while the inclination increased. Movements in an opposite sense, which were very rare, can only be looked upon as movements of reaction. The ways and manner of the magnetic disturbances are highly interesting. While all other natural phenomena became apparent to our senses, be it to the eye, ear, or touch, this colossal natural force only shows itself by these scientific observations, and has something mysterious and fascinating on account of its effects and phenomena being generally quite hidden from our direct perception.

The instrument upon which Lieut. Weyprecht placed the greatest expectations, namely, the earth-current galvanometer, gave no results at all, through the peculiar circumstances in which the explorers were placed. He had expected to be able to connect the aurora with the galvanic earth-currents. But as the ship was lying two-and-a-half German miles from land, he could not put the collecting plates into the ground, but was obliged to bury them in the ice. Now, as ice is no conductor, the plates were isolated, and the galvanometer needle was but little affected. Prof. Lamont had supplied these excellent instruments also; the conducting wires were 400 feet long. Later on, Lieut. Weyprecht tried to obtain some results by connecting a collector for air-electricity with the multiplier of the galvanometer, but failed, doubtless for the same reason.

The astronomical observations while the ship was still drifting were confined to determinations of latitude and longitude, the latter by chronometers and correction of clocks, by lunar distances, as often as opportunity served. In this only a sextant and a prism circle with artificial horizon were used. When the ship was lying still, a little "universal" instrument was erected, and the determinations of time, latitude, and azimuth were made with this. The longitude was calculated from the mean of as many lunar distances as could be observed during the winter; they were 210 in number. The azimuth of a basis of 2,171 metres long, measured by Lieut. Weyprecht with a Stampfer levelling instrument, was determined with the universal instrument of the magnetic theodolite. All this work was done by Ensign Orel, Lieut. Weyprecht only taking a share in measuring lunar distances. The determinations of locality were made without regard to temperatures; if the mercury of the artificial horizon was frozen, blackened oil of turpentine was used instead.

Of the results of the meteorological observations, only some general ideas can be given, as here figures alone decide. They were begun on the day the explorers left Tromsø, and were only discontinued when they left the ship; thus they were made during twenty-two months. Readings were taken every two hours, and also at 9 A.M. and 3 P.M., therefore fourteen times daily. The observers were Lieut. Brosch, Ensign Orel, Capt. Lusina, Capt. Carlsen, Engineer Krusch (from autumn 1872 till spring 1873), and Dr. Kepes (during the last two months only). The direction as well as force of winds were noted down without instruments. Lieut. Weyprecht thinks this method by far the best in Arctic regions, as errors are more or less eliminated, while when using instruments the constant freezing, drifting snow, &c., produce errors that cannot be determined nor controlled; besides, anyone who has been to sea for a short time will soon acquire sufficient exactness in these observations.

Until the autumn of 1873 winds were highly variable. In the vicinity of Nowaja Semlja many S.E. and S.W. winds were observed; in the spring these veered more to N.E. A prevalent direction of winds was only recognised when in the second winter the expedition was near Franz-Joseph's Land. There all snowstorms came from E.N.E., and constituted more than 50 per cent. of all winds. They generally produced clouded skies, and the clouds only dispersed when the wind turned to the north. The explorers never met with those violent storms from the north, from which the *Germania* party had so much to suffer on the east coast of Greenland, and which seem to be the prevalent winds in the Arctic zone. Altogether, they never observed those extreme forces of wind which occur regularly in our seas several times in every winter (for instance, the "Bora" in the Adriatic). Every Arctic seaman knows that the ice itself has a calming effect upon the winds; very often white clouds are seen passing with great rapidity, not particularly high overhead, while there is an almost perfect calm below.

One peculiarity must here be mentioned. Lieut. Weyprecht made the remarkable discovery that the ice never drifted straight in the direction of the wind, but that it always deviated to the right, when looking from the centre of the compass; with N.E. wind it drifts due W. instead of S.W.; with S.W. wind it drifts due E. instead of N.E.; in the same manner it drifts to the north with S.E. wind, and to the south with N.W. wind. There was no exception to this rule, which cannot be explained by currents nor by the influence of the coasts, as with these causes there would be opposite results with opposite winds. Another interesting phenomenon in both years was the struggle between the cold northern winds and the warmer southern ones in January, just before the beginning of the lasting and severe cold; the warm S. and S.W. winds always brought great masses of snow and produced a rise in the temperature amounting to 30–35° R. within a few hours.

Little can at present be said on the result of the barometer readings, without a minute comparison of the long tables of figures, although very extreme readings occurred at times. The explorers had three mercury and four aneroid barometers; by way of control, Ensign Orel took the readings from five of these instruments every day at noon, while the intermediate observations were made with an aneroid.

The thermometers were suspended about four feet from the surface of the snow, in the open air, and perfectly free on all sides, about twenty-five yards from the vessel. Excepting the maximum thermometers, they were all spirit thermometers, made by Cappellet of Vienna. They were often compared with a very exact normal thermometer of the same make. Readings from a minimum thermometer were noted daily at noon; during the

summer a black bulb thermometer was exposed to the rays of the sun; during the winter frequent observations were made with exposed and covered minimum thermometers to ascertain the nightly radiation at low temperatures. In both winters February was the coldest month, while January both times showed a rise in the temperature when compared either with December or February. In winter the temperature was highly variable, and sudden rises or falls were frequent; in the three summer months, however, the temperature was very constant, and changes very rare. July was the warmest month. The lowest reading was  $-37\frac{1}{2}^{\circ}$  R. (nearly  $-47^{\circ}$  C.) The influence of extremely low temperatures upon the human body has often been exaggerated; there are tales of difficulty in breathing, pains in the breast, &c., that are caused by them. Lieut. Weyprecht and his party did not notice anything of the kind; and although many of them had been born in southern climes, they all bore the cold very easily indeed; there were sailors amongst them who never had fur coats on their bodies. Even in the greatest cold they all smoked their cigars in the open air. The cold only gets unbearable when wind is united to it, and this always raises the temperature. Altogether, the impression cold makes upon the body differs widely according to personal disposition and the quantity of moisture contained in the air; the same degree of frost produces a very uncomfortable effect at one time, while at another one does not feel it.

To determine the quantity of moisture in the atmosphere, an ordinary psychrometer, a dry and a wet thermometer, were used. But the observations with these instruments are not reliable at low temperatures, and had to be given up altogether during winter, as the smallest errors give great differences in the absolute quantity of moisture in the air. In order to determine approximately the evaporation of ice during winter, Lieut. Weyprecht exposed cubes of ice that had been carefully weighed to the open air, and determined the loss of their weight every fourteen days.

(To be continued.)

#### PRIZES OFFERED BY THE BELGIAN ACADEMY

THE following subjects for prizes to be awarded in 1866 have been proposed by the Royal Academy of Sciences, Belgium:—

1. To improve in some important point, either in its principles or applications, the theory of the functions of imaginary variables.

2. A complete discussion of the question of the temperature of space, based upon experiments, observations, and calculation, stating the grounds for the choice made between the different temperatures attributed to it.

Competitors should observe that the above question, stated in the most general terms, is connected with the knowledge of the absolute zero, definitely fixed at  $-273^{\circ}$  85 C., but that a historical and analytical inquiry into researches undertaken, previous to about 1820, to resolve this question, would offer a real scientific interest. Particular attention is called to the works of the end of the eighteenth century and the commencement of the nineteenth; among others, those of Black, Irvine, Crawford, Gadolin, Kirwan, Lavoisier, Lavoisier and Laplace, Dalton, Desormes and Clément, Gay-Lussac, &c. Note also the temperature,  $-160^{\circ}$  C., which Person indicates; according to his formula, which connects the latent heat of fusion with specific heats, this number would represent the absolute zero. As it comes near to that given by Pouillet, it will be important to discover what is its signification, its import (*sens*), or its exact physical value.

3. A complete study, theoretical and, if necessary, experimental, of the specific absolute heat of simple and of compound bodies.

4. New experiments on uric acid and its derivatives, chiefly from the point of view of their chemical structure and their synthesis.

5. New researches into the formation, the constitution, and the composition of chlorophyll, and into the physiological rôle of that substance.

6. To expound the comparative anatomy of the urinary apparatus in the vertebrates, basing it on new organogenic and histological researches.

The prize for the first, the fourth, and the sixth questions will be a gold medal of the value of 800 francs, the prize for the fifth

will be of the value of 600 francs, and the prize for the second and third questions will be of the value of 1,000 francs.

The memoirs must be legibly written, either in French, Flemish, or Latin. They should be addressed, carriage-paid, to M. J. Liagre, Perpetual Secretary of the Academy, at the Museum, before August 1876; any received after which will be out of the competition.

Authors must not put their names to their works. Only a motto must be attached, and the same written outside an envelope enclosing the author's name and address. This condition is indispensable.

#### SOCIETIES AND ACADEMIES LONDON

Mathematical Society, March 11.—Prof. H. J. S. Smith, F.R.S., president, in the chair.—Mr. Roberts gave an account of his paper on a simplified method of obtaining the order of algebraical conditions.—Prof. Sylvester, F.R.S., then spoke on "an orthogonal web of jointed rods, a mechanical paradox." If two sets of points be taken respectively in two lines perpendicular to each other, either in a plane or in space, and a linkage be formed by connecting each point in one set with each point in the other by jointed rods, this constitutes what the author means by an orthogonal web. It is not a fixture, and its motion is subject to this curious condition, that either each set of points must always continue to lie in the same right line, which may be called a neutral position, or else one set will lie in a right line and the other in a plane at right angles to such line. Starting from the neutral position (or position of *double-lock*), the system may be said to be subject to an optional locking about one or the other of the two perpendicular lines, and an unlocking about the other, but when once put in motion the system must be again brought into the same or a new neutral position before the one axis of lock can be got rid of, and another at right angles thereto substituted in its stead. If the whole motion be confined to a plane, the paradox consists in the link-combination possessing one degree of liberty of deformation (*αλλοιωσις* as distinguished after Plato from *κίνησις*), although a calculation of the amount of restraint by the general method applicable to such questions would seem to indicate that it ought to form an absolutely rigid system except in the case where there are only two joints in one at least of the two sets. Taken in space there is the further and more striking paradox that the number of degrees of liberty of deformation according to the choice made of one or the other of the two sets of points to be unlocked out of the rectilinear into the planar position will be the *alternative* of two numbers, viz. the number of joints in the one set or in the other set (which need not be the same), a kind of indeterminateness in the "index of freedom" without precedent in kinematical speculations. As lightning clears the air of impalpable noxious vapours, so an incisive paradox frees the human intelligence from the lethargic influence of latent and unsuspected erroneous assumptions. Paradox is the slayer of prejudice.—The Secretary, in the author's absence, then read a portion of Mr. G. H. Darwin's paper on some proposed forms of slide-rule. The object of the author was to devise a form of slide-rule which should be small enough for the pocket and yet be a powerful instrument. The first proposed form was to have a pair of watch-spring tapes graduated logarithmically, and coiled on spring bobbins side by side. There was to be an arrangement for clipping the tapes together, and unwinding them simultaneously. Two modifications of this kind were given. The second form was explained as the logarithmic graduation of several coils of a helix engraved on a brass cylinder. On the brass cylinder was to fit a glass one, similarly graduated. To avoid the parallax due to the elevation of the glass above the other scale, the author proposed that the glass cylinder might be replaced by a metal corkscrew sliding in a deep worm, by which means the two scales might be brought flush with one another.

Anthropological Institute, March 9.—Col. A. Lane Fox, president, in the chair.—Sir Duncan Gibb read a paper on Ultra Centenarian Longevity, in which he exhibited some tables giving eighty-four instances of the reputed age of 107 to 175 years, a certain proportion of which he considered he had grounds to believe to be correct. Of nine living centenarians whom he had previously examined for physiological purposes, he now added a tenth—the Tring centenarian—who died recently in her 112th year. The correctness of her age was considered

in an exhaustive manner, and the reasons were given to justify this conclusion. Mainly they consisted of the discovery of the register of her baptism at Chinnor, Oxford, in 1763, from information furnished by herself; the birth of her first child Samuel, when she was between twenty-nine and thirty; the drowning of him and some thirty-four other persons by a catastrophe at Hadlow in 1853, when his age was stated to be fifty-nine on his monument; and the calculation of dates and other circumstances in the old dame's family history. The proofs were altogether on the side of certainty, whilst any objections that could be brought forward were of the feeblest character, especially such as the inability to find a register of the marriage with her husband, who was a soldier in the Bucks Militia. Her physical condition, from careful examination during life in October 1873, was next described, when all the organs and functions of the body were, for the most part, found to be healthy, and corresponded to those of a person a fifth of her age. All that was confirmed in every respect by inspection after her death in January last, and the results proved the absence of the usual well-known senile changes, which explained the fact, as the author stated, that not only she, but the nine other persons he had examined, were enabled to reach the age of 100 years, and even to overstep it. Yet, with the attainment of such a great age, there was always an amount of feebleness present which very slight causes influenced, and thus life soon came to an end. In the old dame the merest chill or slightest possible cold extinguished the spark of life. The occurrence of a well-authenticated case like hers readily explained the fact that now and then, under peculiarly favourable circumstances, especially in a more equable climate than our own, the century is exceeded by several decades. And the occurrence of such great ages as have been recorded from time to time by honest and conscientious inquirers of former years, need not be looked upon with doubt, much less with distrust, for the anxiety to prove the correctness of such ages was as great then as it is now.—Previous to the ordinary meeting, a special general meeting of the members was held to authorise an application to the Board of Trade for a license, and to adopt the draft memorandum and articles of association for the incorporation of the Institute. It was also resolved that ladies be admitted as members with all the usual privileges.

Royal Horticultural Society, Feb. 17.—Scientific Committee.—Mr. A. Murray, F.L.S., in the chair.—Dr. Masters showed fruit of *Fuchsia procumbens*. The Rev. M. J. Berkeley exhibited leaves of *Thea Bohea*, from the Natal Botanic Garden, affected with a lichen, *Strigula Feci*, Mont. Mr. Keit, the curator, states that it makes its appearance as a minute speck of brown colour which gradually enlarges in circumference till the end of the season, when the margin assumes a pale green colour, and ceases to grow. Mr. Berkeley found that the brown substance was composed of a species of *Cephalosporium*; it consisted of decumbent articulated threads, each of which has at its tip a globose sporangium. It is very near *Chroolepus*, and if some lichens are parasitic on *Chroolepus*, this may be on *Cephalosporium*.—Prof. Thiselton Dyer exhibited specimens of *Bariidius aterrimus*, an insect most destructive to orchids at Singapore. He also called attention to the occasional formation of tubers within potatoes, which he believed to be due to ingrowing shoots derived from the eyes.—A portion of a letter from Santarem, addressed by Mr. Trail to Dr. Hooker, was read, describing the ant-inhabited bulle on the leaves of some *Melastomaceae*. After careful examinations Mr. Trail was quite at a loss to determine the exact connection between the bulle and the ants, of which at least three species inhabit them.

General Meeting.—W. Burnley Hume in the chair.—The Rev. M. J. Berkeley remarked that he had placed some very old specimens of *Micrococcus prodigiosus* (blood rain) on rice paste, and they had recommenced growing, and had spread as far as could be expected from the state of the weather. According to Mr. Stephens, the plant retains its power of vegetation after it has been in an oven forty-eight hours.

March 3.—Scientific Committee.—Dr. Hooker, C.B., P.R.S., in the chair.—The Rev. M. J. Berkeley read a letter from Mr. Moseley, the naturalist on board the *Challenger*, relating to a fungus, *Sphaeria sinensis*, growing out of a caterpillar and used as a delicacy by the Chinese.—Prof. Thiselton Dyer showed a ball formed by the action of the sea out of fragments of *Callistia* from the shore at Mentone, collected by the late Mr. Moggridge.—A discussion arose as to the effect of lichens on trees in connection with the occurrence of species of *Strigula* on the leaves of the tea plant, and the injury which is found to arise in mowing

the stems of *Cinchona* in India after removing the bark, if lichens are mixed with the moss. The Rev. M. J. Berkeley thought that all the evidence was against any penetration of the hyphae of the lichen into the subjacent tissues of the plant upon which the lichen grew. The lichens were injurious by preventing the access of light and air. If they were scraped off the branches of apple-trees infested by them, and the surface were washed, the tree soon recovered, which would not be the case if the hyphae had penetrated into its tissues.—Dr. Bastian said that he had examined some of the nematoid worms found in the swellings on the roots of cucumbers. They were, however, too immature to determine their genus.—Dr. Masters alluded to a Chinese primrose exhibited, in which there was a partition throughout the leaves, stem, and inflorescence of colour. He thought that this was an instance of dissociation of hybrid characters. A similar bilateral partition of colour sometimes took place in plants raised from cuttings, when of course the above explanation would not apply.

General Meeting.—Bonamy Dobree, treasurer, in the chair.—The Rev. M. J. Berkeley addressed the meeting. He called attention to the gigantic Sweet Potato (weighing over 15 lbs.), *Convolvulus Batatas*, from Madeira, shown by Dr. Hooker; a branch of the Kumquat, *Citrus japonica*, with fifty-six fruits; and a charming miniature Orchid, *Masdevallia melanopus*.

Physical Society, Feb. 27.—Prof. Gladstone in the chair.—Mr. Wills, F.C.S., submitted to the Society apparatus which he had devised for exhibiting the sodium spectrum to an audience. The experiment as usually shown consists in volatilising the metal or one of its salts between the carbon poles of a lamp and in projecting the spectrum on to a screen. The method is imperfect, as the characteristic lines of sodium are always associated with the continuous spectrum of the electric light. Mr. Wills prefers, therefore, to obtain a sodium flame by burning hydrogen which has been passed over the surface of the molten metal; by this means a pure sodium spectrum may be thrown on the screen. Prof. McLeod suggested that other metals might be introduced into the hydrogen flame in a finely-divided state, and that the continuous spectrum might be eliminated by employing a horizontal slit.—Prof. G. C. Foster then read a paper, by himself and Mr. J. O. Lodge, on the lines of flow and equipotential lines in a uniform conducting sheet. The first experimenter who worked on this subject was Kirchhoff, who used plates of copper, but owing to their small dimensions, his measurements were imperfect. Quincke employed rectangular plates, and afterwards discs of lead and copper conjointly, so that he obtained a difference of potential at the junction. The next experiments were made by Prof. Robertson Smith, who used conducting discs of tinfoil and deduced equipotential lines from the lines of flow. Prof. Foster stated that the general mathematical theory had been fully established by Kirchhoff, who had verified it experimentally in all its main features. The object of the authors of this paper had in view was to show that Kirchhoff's results can be arrived at by very simple mathematical processes, if each electrode by which electricity is supplied to or taken from the sheet be regarded as producing everywhere the same effect as it would if it were the only electrode in the sheet. The electrical condition of every point in the sheet thus appears to result from the simple superposition of the effects due to the several electrodes. This mode of treating the question has been adopted by Prof. Robertson Smith, but his paper was in the main addressed to mathematical readers. It was the aim of the authors, however, to show that the chief results could be established by elementary methods which can be included in ordinary class teaching. The paper contained, in addition to the mathematical discussion of the subject, a description of an experimental method of laying down the equipotential lines on a conducting surface, so that the difference of potential between any two consecutive lines may be constant. Measurements were also given of the resistance of discs of tinfoil of various sizes, and with the electrodes in various positions. The results agreed closely with the calculated values, and thus supplied a verification of the theory which Kirchhoff had been unable to obtain in consequence of the small resistance of the discs used by him. Mr. Latimer Clark made some observations on the methods by which contact was made between the electrodes and the conducting sheet, and Prof. Adams then described some of the results which he had just communicated to the Royal Society, on lines of force.

Entomological Society, March 1.—Sir Sidney Smith Saunders, president, in the chair.—Mr. F. H. Ward exhibited living



specimens of a *Lepisma*, allied to *L. saccharina*, which he had not previously observed in this country. They were found in a bakehouse near London, in the brickwork of the oven and other warm parts of the buildings. Mr. M'Lachlan suggested that they might have been introduced with American flour, as Mr. Packard had recently published an account of a species closely allied to *L. saccharina*, which he thought might probably be found identical with the present species.—Mr. Ward also exhibited microscopic slides showing the sexes of the Chigoe, and portions of the human skin with the insect attached.—Mr. Champion exhibited larvae of *Empusa papyrata* from Corfu.—A note was received from Mr. W. C. Bayard with reference to some fleas exhibited at the last meeting. He stated that fleas were frequently found in the inside (not the outside) of the ears of wild rabbits, especially about this time of year; and that his brother had seen a rabbit which must have had three hundred fleas in the two ears. He believed the rabbits were not much troubled by the presence of the parasites, as he had never noticed any inflammation, however many fleas there might have been.—The Rev. Mr. Gorham communicated a paper containing descriptions of eighteen new species of *Endomyzidæ*, from various tropical countries.—Mr. Dunning directed attention to an interesting paper by Dr. Leconte, on entomological nomenclature and generic types, which appeared in the December part of the *Canadian Entomologist*.

## EDINBURGH

Royal Society, March 15.—David Milne Home, LL.D., vice-president, in the chair.—The Council having awarded the Makkougall Brisbane Prize for the Biennial Period 1872-74 to Prof. Lister, for his paper on the germ theory of putrefaction and other fermentative changes, the medal was presented to him by the chairman, after a discourse by Dr. Crum-Brown upon the nature and merits of Prof. Lister's investigation.—The Council have awarded the Neill Prize for the Triennial Period 1871-74 to Mr. Charles William Peach, for his contributions to Scottish zoology and geology, and for his recent contributions to fossil botany.—The following communications were read:—On the diurnal oscillations of the barometer, by Alex. Buchan, M.A.; on phenomena connected with the subject of single and double vision, as shown by the stereoscope, by Robert S. Wyld; on products of oxidation of methyl-thetine, by Prof. Crum-Brown and Dr. Letts.

## CAMBRIDGE

Philosophical Society, Feb. 22.—A communication was made by the Rev. O. Fisher, upon the formation of mountains on the hypothesis of a liquid substratum. This paper was a sequel to one read in December 1873, in which it had been shown that, upon the supposition that the inequalities of the earth's surface have been formed by contraction of its volume through cooling, they are too great to be so accounted for if the earth has cooled as a *solid* body. In the present communication it was therefore assumed that there is a *liquid* layer beneath the cooled crust; and an approximate calculation was made of the form which the corrugations of a flexible crust would take if so supported. It was shown that their lower surface would consist of a series of equal circular arcs arranged in a festoon-like manner, and having a radius  $2\rho^2/c$ , where  $\rho$ ,  $\sigma$  are the densities of the crust and liquid respectively, and  $c$  the thickness of the crust. It was argued that the consequences of this form of corrugation agree fairly well with some of the phenomena of mountain elevation, but that it does not suffice to explain the ocean-basins and the continental plateaux.

## GLASGOW

Geological Society, Feb. 11.—Annual Meeting.—The president, Sir William Thomson, LL.D., F.R.S., delivered an address on Underground Temperature. Sir William explained at the outset that the mathematical theory of underground temperature involved phenomena which might be divided into two classes—periodic and non-periodic. The periodic phenomena occurred over and over again with perfect regularity in successively equal intervals of time; the non-periodic might be approximately periodic, or irregularly periodic, without strictly fulfilling that definition. But, on the other hand, the action which had no periodic character whatever might be irregular, or there might be a gradual secular variation. There might thus be three classes of phenomena—secular variation, irregular variation, and periodic variation. He then described the mathemat-

ical theory of Fourier, as applied to periodic variations, observing in passing that it was equally convenient for dealing with all the three classes. That theory was one of the most beautiful pieces of application of the mathematical instrument which they had in the whole history of science. It constituted a new branch of mathematics, and was invented by Fourier for the purpose of analysing the phenomena of the conduction of heat through solids. He exhibited a diagram showing the results obtained by Forbes from thermometers placed at depths of three, six, twelve, and twenty-four feet below the surface in Craighleith Quarry, the Experimental Gardens, and the Calton Hill, Edinburgh. The results of these observations which Forbes commenced, and Sir William continued for seventeen years, showed that the variations were greater nearer the surface, that a higher temperature was generally indicated at a later period at the greater depth, and seemed to show also that the sandstone of the Craighleith quarries had a greater conductivity than the trap-rock. Sir William concluded by referring to the temperature of the earth as indicating its former condition, and promised at some future time to treat this subject at greater length before the Society.

## DUBLIN

Royal Geological Society, Feb. 11.—Prof. Hull, F.R.S., president, occupied the chair, and delivered the anniversary address, in the course of which he pointed out some subjects where investigation on the part of members of the society seemed desirable. One of these was cave explorations in Ireland, an investigation which had been pursued with very great success in England and France, and along the shores and islands of the Mediterranean. Prof. Hull mentioned a number of interesting discoveries of animal and other remains that had been made in the caves of Ireland, which he said furnished proofs of the wide field of research that was open to them. Another subject which he recommended to the consideration of the members was the microscopic examination of rocks, and he hoped that the many curious rock-formations to be found throughout Ireland would be studied and reported upon by those who felt an interest in the matter.—Sir Robert Kane, F.R.S., was elected president for the year.

## BOOKS AND PAMPHLETS RECEIVED

BRITISH.—Consumption and Tuberculosis; their Proximate Cause and Specific Treatment by the Hyppophosphites; John Francis Churchill, M.D., Paris (Longmans).—Problems of Life and Mind. Vol. II.; George Henry Lewes (Tinsley).—The Marine Invertebrates and Fishes of St. Andrews; W. C. McIntosh, M.D., F.R.S.E., C.M.Z.S., &c. (A. and C. Black, and Taylor and Francis).—A Whaling Cruise to Baffin's Bay. 2nd edit.; Capt. A. H. Markham (Sampson Low and Co.).—Facts about Breadstuffs (Porteous)—Astronomy; by J. Ramboson. Translated by C. L. Pitman (Chapman and Hall).—Ornithology and Conchology of the County of Dorset; J. C. M.P.—Proceedings of the Royal Society of Edinburgh, 1873-74.—Instructions for the Observation of Phenological Phenomena. Prepared by request of the Council of the Meteorological Society (Williams and Strahan).—Catalogue of the Library of the Manchester Geological Society. Edited by John Platt, F.G.S.

AMERICAN.—Principles of Chemistry, and Dr. Hinrich's Molecular Mechanics (Davenport, Iowa, U.S.).—Annual Report upon the Survey of Northern and North-Western Lakes in charge of C. B. Comstock (Washington).—Bulletin of the United States Geological and Geographical Survey of the Territories: 2nd series, No. 1 (Washington).

## CONTENTS

	PAGE
SCIENTIFIC SURVEYS . . . . .	382
THE COUNTESS OF CHINCHON . . . . .	383
GERLAND'S "ANTHROPOLOGICAL CONTRIBUTIONS" . . . . .	374
OUR BOOK SHELF:—	
Hartwig's "Aerial World" . . . . .	385
LETTERS TO THE EDITOR:—	
A Gyrostat Problem ( <i>With Illustration</i> ).—D. McFARLANE . . . . .	385
Origin of the Chesil Bank.—Col. GEORGE GREENWOOD . . . . .	386
Natural Phenomena in South America.—THOMAS R. R. STEBBING . . . . .	386
Volcanic Action in the Sandwich Islands.—ISABELLA L. BIRD . . . . .	386
The Height of Waves.—Capt. WM. W. KIDDLE . . . . .	386
OUR ASTRONOMICAL COLUMN:—	
Variable Stars . . . . .	387
Mars and 3 Sagittarii, 1875, June 29 . . . . .	387
Erick's Comet . . . . .	387
THE TRANSIT OF VENUS . . . . .	387
THE PROGRESS OF THE TELEGRAPH, I. ( <i>With Illustrations</i> ) . . . . .	390
ON SOME REMARKABLE CHANGES PRODUCED IN IRON AND STEEL BY THE ACTION OF HYDROGEN AND ACIDS. BY W. H. JOHNSON, B.Sc. . . . .	393
THE SOUTHPORT ACQUARIUM. BY CHARLES E. DE RANGE . . . . .	393
NOTES . . . . .	394
SCIENTIFIC REPORT OF THE AUSTRO-HUNGARIAN NORTH POLAR EXPEDITION OF 1872-74, II. . . . .	396
PRIZES OFFERED BY THE BELGIAN ACADEMY . . . . .	398
SOCIETIES AND ACADEMIES . . . . .	398
BOOKS AND PAMPHLETS RECEIVED . . . . .	400

THURSDAY, MARCH 25, 1875

## LUBBOCK'S "ORIGIN OF CIVILISATION"

*The Origin of Civilisation, and the Primitive Condition of Man: Mental and Social Condition of Savages.*  
By Sir John Lubbock, Bart., M.P., F.R.S., &c. Third Edition. (London: Longmans, Green, and Co.)

THE third edition of Sir John Lubbock's well-known book has followed so close upon the second, that the author, busy man as he is, might have been excused had he given us a mere reprint; but he has included in it additional matter which adds very considerably to its value. Nearly every chapter has been enlarged, and a chapter on the Development of Relationships has been added, which appears to us to be at least as good and useful a bit of work as Sir John Lubbock has hitherto done. To show the changes which have been made at points throughout the book is out of our power, nor does this seem to be necessary, as the changes do not, we think, in any case affect his previous conclusions otherwise than by adding to the evidence on which they rest. The new chapter is what calls for notice, and to it this notice shall for the most part be confined. The facts with which he deals in this chapter have been taken from the voluminous work of the American author, Mr. Morgan; but Sir John Lubbock, putting aside Mr. Morgan's theorising, has submitted a view of them of his own. This, in the main, and so far as it goes, we think, he has made out.

The facts collected by Mr. Morgan (though he had the assistance of the United States Government, the collection must have cost him an infinity of trouble) show the existence, widespread, among the lower races of mankind, of systems of relationships strangely different from that which exists in Europe, transmitted without material change from the Aryan nations from whom we claim descent. In these systems (to describe them, so far as can be done, by the incidents which are common to the greatest number of them) all the brothers of a family are each called father, and regarded as a father, by the children of the whole brotherhood; and all the sisters of a family are each called mother, and regarded as a mother, by the children of the whole sisterhood; while the children of brothers regard each other, and also the children of sisters of their respective mothers, as brothers and sisters, and are acknowledged as children equally by their true father and his brothers and their true mother and her sisters. This holds good of all putative brothers and sisters, and accordingly a man regards the children of a male cousin through his father's brother or his mother's sister as his children, and is by them called father; he regards the grandchildren through a male of such a cousin as his grandchildren, and is by them called grandfather. Similarly a woman regards the children of a female cousin through her father's brother or her mother's sister as her children, and is by them called mother; and the grandchildren through a female of such a cousin are her grandchildren, and call her grandmother. All the brothers of a grandfather are grandfathers, and all the sisters of a grandmother are grandmothers. In nearly all the cases in which this curious nomenclature—and it is much more than mere nomenclature, though, strictly speaking,

it is not a description of *relationships*—is in use, a special term is applied to a mother's brother by her children, and a special term applied to children by their mother's brother. These terms are inadequately represented by our words uncle and nephew, for they denote what the terms father and son do not in these cases usually involve—relationship being counted through females only—a recognised blood-relationship, which carries to the uncle the right and duty of exercising on behalf of his nephew such care and supervision as in more advanced communities are exercised by a father, and gives the nephew, on the other hand, the right of succession to his uncle's property. In cases not quite so numerous a special term is applied also to a father's sister, who then in turn calls her brother's children by the term applied by the brother to her children; she is an aunt, and her brother's son is her nephew. In a still more limited number of systems the terms devised for real brother and sister and their children are applied to all putative brothers and sisters and their children. Where these special terms are all in use, brother's and sister's children are in some cases considered brothers and sisters; and then the rules applicable to all putative brothers and sisters and their offspring being applied, the cousins are regarded as the fathers, mothers, or uncles, aunts of each other's children, according as the relationship arises through two male cousins, two female cousins, or a male and female cousin. In more numerous cases, the children of a brother and sister, or of a putative brother and sister, are distinguished by a special term, *i.e.*, they are called cousins. In a considerable number of these, however, a cousin's son is addressed as if he were the son of a brother or sister—that is, either as son or nephew; and, in nearly all, a cousin's son's son is, as if he were a brother's son's son, termed a grandson. A very few of the systems of relationship, particulars of which have been collected by Mr. Morgan, fall below the description given above; in these a mother's brother is considered as a father, a father's sister as a mother, and terms for cousinry are unknown. There are others, the number of which is considerable, which are of a higher kind, which are nearer, that is, by one or more steps to our own system of relationship—applying, *e.g.*, special terms as little father or stepfather to a father's brother, special terms as little mother or stepmother to a mother's sister, and special terms to the relationship of the children of two brothers or two sisters. All the systems which have been brought under notice, however, in whatever respects they differ, agree in considering a grandfather's brother to be a grandfather, a grandfather's sister to be a grandmother, and, on the other hand, a grandson of a cousin—whether called cousin, step-brother, or brother—to be a grandson.

In these points of agreement is found the explanation of the relation between the various systems. Sir John Lubbock's conclusion that these, in the higher systems, are relics of previous lower stages of development, which it has perhaps not been thought worth while to get rid of, appears to be irresistible. They suggest a time in the history of each system, be it now what it may, when all brothers were equally the fathers of each other's children, when all cousins, even the children of brother and sister, were

equally brothers and sisters, and, therefore, a time when a mother's brother was a father, and a father's sister was a mother. The systems can be ranged in a series which makes the truth of this view almost self-evident. In the rudest systems noticed by Mr. Morgan the mother's brother is a father, and the father's sister is a mother; brother and sister's children are brothers and sisters, fathers or mothers of each other's children, grandfathers or grandmothers of each other's grandchildren. Above these are the systems in which special terms have been devised for the peculiar relationship between children and their mother's brother, and (in most cases) for the father's sister also—in which, as has been seen, the children of brother and sister are in some cases called brother and sister, but more commonly cousin, while the children of one of such cousins are in many instances regarded by the other cousins as their children, and his grandchildren in every case are regarded by them as their grandchildren. So far there is unmistakable evidence of a progress made through dint of thinking over social facts. Extension of our survey to more advanced systems simply shows that in them a similar progress has been carried further. Such terms as little father or stepfather applied to a father's brother, for example, are not hard to reconcile with the view that a father's brother was at a former stage regarded as a father; and when it is considered that a grandfather's brother is in such cases a grandfather, no shadow of doubt on the subject can remain. That there are some facts of which Sir John Lubbock cannot give the solution must be admitted, and these are not unimportant; but they in no way affect the validity of his argument that there has been a development of relationships from a very rude germ, and that what may be called the modern system of relationships has been arrived at by a long and very gradual progress. The explanation of them must be sought in a more careful examination of the marriage customs of the races in which they occur. Moreover, there are not wanting eccentricities of terminology, the key to which cannot in all cases be had; but usually these are obviously the result of the over-rigid application of general rules following upon a false start. The Crow Indians, for example, call their mother's brother an elder brother, which is not so very wrong in itself; but they go on to call his son (as being the son of one called brother) by the name of son. Departures from the normal type of this kind are, of course, to be looked for wherever a system has been independently developed by many bodies of men.

It is among what Mr. Morgan calls the Turanian, American Indian, and Malayan families of men that the systems of relationship above considered are known to prevail. The lowest forms are found in the Sandwich Islands and their neighbourhood, and among one or two of the American Indian tribes; the middle systems among the Tamil races of India, the American Indians, the Fijians, and the Tongans; while the Karens and the Esquimaux supply the most advanced. One of Mr. Morgan's theories (for he has, or seems to have, two which it is no business of ours to reconcile with each other) is, that these systems are, to use the words of Sir John Lubbock, "arbitrary, artificial, and intentional." Mr. Morgan holds that ethnological affinities can be traced by their aid, and accordingly he is disposed to believe in the

common origin of the Tamil and Red-skin races. The same reasoning would identify the Fijians and the Tongans with both these races, and with one another—if it would not also show that the Two-mountain Iroquois of North America are of the same descent as the Malayan races, and no relatives of their Red-skin neighbours. This looks like a *reductio ad absurdum*; but it really is not necessary to consider the hypothesis that the systems of relationship under notice are purely factitious—a wildly improbable hypothesis—when a sufficient explanation of their relation to each other, which traces them all to a comparatively simple low form, is forthcoming. Of the origin of this lowest known system of relationships Sir John Lubbock wisely offers no theory, content with suggesting that the right which a husband among the American Indians is said to possess, of marrying his wife's sisters as they successively come to maturity, may explain why a woman's sisters are considered the mothers of her children. The so-called "communal marriage" clearly cannot be the explanation. Supposing that "communal marriage" could give rise to a system of relationships, all the full-grown men of a tribe must have been equally considered fathers of all the children of the tribe. But the facts collected by Mr. Morgan all point to a more limited amount of fatherhood than this; and to account, from the communal marriage point of view, for the Hawaiian limitation, is about as difficult as it is, from the European point of view, to understand the Hawaiian extension, of fatherhood. The influence of the custom of counting kindred through females only on the development of systems of relationship has been indicated; it is by means of it that the departure from the simplicity of the Hawaiian system was made. This Sir John Lubbock has clearly pointed out. It is only fair to Mr. Morgan to state that, notwithstanding his theory above referred to, he has not neglected to do the same.

After so much exposition a little criticism may be not out of season, and to begin with a phrase which has just been mentioned, "communal marriage," we cannot help regretting that Sir John Lubbock, in his chapter on Marriage, has made so much use of it, since beyond question it is unprecise and misleading. Sir John exhibits a number of facts, all of which, with one doubtful exception, point to the entire absence among certain tribes of the very germ of a marriage law, and to this he gives the name of communal marriage. If this were a mere matter of phraseology, it would be hypercritical to say anything about it; but Sir John goes on to argue as if he had shown that, in a tribe without any law of marriage, every man was the lawful husband of every woman—as if, in fact, there were a defined, though unusually free system of marriage *right*, while what the evidence goes to show is that such a thing never was even thought of. The view just noticed has had no inconsiderable influence over his opinions about Marriage; and it seems, to say the least, unsafe to allow it any weight whatever. Of tribes which [have had no marriage law, all we really know is, that in the intercourse of the sexes nothing was deemed by them wrong, and this state of feeling seems to involve the non-existence of any idea of marriage right. Without evidence, at any rate, we are unable to believe that this idea, as postulated

by Sir John Lubbock, could have been generated in the circumstances, and of evidence, so far as we know, there is not a trace. Sir John Lubbock's theory of the origin of monandric marriage, exogamy, and the form of capture, also seems open to observation. He ascribes monandric marriage to the appropriation, in tribes without any marriage law, of captured women by individual captors; supposing that a captured woman, as she did not belong to the tribe, would be readily left with the man who took her; that envy of the superior felicity attained by captors would lead to a frequency of capture, until, at length, the possession of a captured woman became the ambition and hope of every man of a tribe; and that there being no other way than capture of getting a wife of one's own, the custom of exogamy was in fact established, becoming a defined tribal law as capture, and therewith monandric marriage, became frequent, and thereafter surviving, as such customs do survive, when wives were got by purchase or exchange, with the capture symbolised. Among savages, however, women are no unconsidered trifles; and the proposition that, when captured, they would be freely left to their captors is so far from being self-evident that it might reasonably be deemed improbable, and certainly requires an amount of support which Sir J. Lubbock has failed to give it. But apart from this, it is, we are disposed to think, fatal to Sir J. Lubbock's hypothesis, that it overlooks the fact that captures of women are usually made by *parties*, not by single persons, and that it is a conflict between *parties* which, as a rule, is symbolised in the form of capture. In ascribing to the prevalence of the capture of wives the curious custom which forbids a father-in-law and mother-in-law to speak to their son-in-law—indignation at the capture being presumed to be the foundation of this rule of non-intercourse—Sir John, we venture to think, has certainly been hasty. At the time when the capture was real and the indignation of the father-in-law and mother-in-law real, their new relative would not have been much in the way of meeting them. He, with his wife, would have been in another tribe than theirs, and that a hostile tribe. Moreover, the same custom prevents a woman from speaking to her father-in-law, and operates, if we mistake not, in other cases also; and these Sir John's suggestion would not explain.

Our criticism shall extend to only one point more, and that is, the explanation offered by Sir John Lubbock of the origin of Totem worship. We notice it the more readily because, in this edition, he puts it forward with some appearance of hesitation. He thinks that the worship of animals may have arisen out of a practice of "naming first individuals, and then their families," after particular animals. "A family which was called after the bear would look on that animal first with interest, then with respect, and at length with a sort of awe." But does not this sound as if Sir J. Lubbock believed that the world began with the patriarchal family system? With it the transmission of a name through an individual, first to a family and then to a tribe, would offer no difficulty. It is necessary, however, to explain the worship of animals in tribes which acknowledge kinship through females only; in tribes in which children take the tribal name, not of their father but of their mother; and in which the family, still in an extremely undeveloped state, was probably altogether unknown at

the distant time when animal worship arose. In such tribes a man's personal name dies with him. Though he has his "medicine," it goes to no successor. It is the women, who, by the way, are without the "medicine," who transmit the totem. That names given to individuals, especially if the individuals were men, should diffuse themselves through tribes of this kind, and this in the case of an endless number of such tribes, appears altogether impossible. This, however, after all, only means that we cannot see how the thing can have happened; and, on the other hand, if Sir John Lubbock should find that in his theorising he has overlooked some of the most perplexing of the facts to be accounted for, he need not greatly grieve. He is entitled to reflect that, allowing for all shortcomings, his book has a sterling value and has done a most useful work.

#### KINAHAN'S "VALLEYS, FISSURES, FRACTURES, AND FAULTS"

*Valleys, and their Relation to Fissures, Fractures, and Faults.* By G. H. Kinahan, M.R.I.A., F.R.G.S.I. (London: Trübner and Co.)

WHENEVER a new explanation of natural phenomena is offered to the public, its advocates, assuming that due importance will be still assigned to the forces to which formerly all had been attributed, frequently seem to ignore them altogether, and therefore other inquirers are generally found who take up the defence of the old view, though they often admit practically as much as is required by the new theory. Mr. Kinahan thinks that sub-aërialists, in explaining the present configuration of the country, have been in the habit of attaching too great importance to surface wear and tear, and of ignoring the effect of fractures produced by earth movements.

Any contribution of facts, well observed and clearly recorded and reasoned upon, is of value, whether or not we accept the deductions of the author. We are, however, unable to satisfy ourselves from the perusal of the work before us that the facts would have appeared to us as they appeared to the author—the references to localities where the evidence for faults and other phenomena may be seen are too vague, and the inferences seem very doubtful.

There are few who would not be prepared to agree with the statement "that the present valleys are not solely due to rain and rivers, but rather to that action combined with glacial and marine denudation, and that all were generally led by the breaks and faults in the rocks" (p. 181), if it means that we must not refer all valleys to rain and rivers exclusively, that denudation of any kind is apt to be directed by the greater or less resisting power of the material to be denuded, and that fractured work is more easily acted upon and denuded than solid work.

What we really have to do is to inquire in each special case which of the various agents have had most to do with the formation of the particular valley, lake, or other earth feature before us; and therefore, in discussing the relation between faults and valleys, we require something more definite than a reference to places, where, as the author says (p. 102), "some of what are here considered faults might possibly only be Silurian cliffs, at the base of which the Old Red Sandstone and limestones were

deposited, as the rocks strike with the line of fault ;" or a map, in which many of the faults upon which the form of a lake is said to depend are drawn altogether below the waters of the lake, and the direct evidence of their direction or even existence is not given in the text (p. 123, and pl. ii. p. 15). Again, anyone who wished to see for himself whether it was possible that "streams have run over polished, scratched, and etched surfaces of rock for ages without having been able to obliterate the ice-marks" (p. 87), could hardly be sure of finding the places referred to by the author from the vague description that they were "among the ice-dressed hills of Galway, Kerry, and Cork" (*ib.*)

We cannot see what right our author has to assume because the "outlines—river-valleys, lake-basins, and bays—occur in systems, the general bearing of which may be indicated by lines," that "if such systems are not caused by breaks in the subjacent rocks, they must be due to chance" (p. 99), when we know that other authors have appealed to this very same fact in support of the theory that the leading features of the country referred to are due to a body of ice moving from the N.E.

It does not seem unreasonable to suppose that valleys which appear to have been shifted (p. 175) may have been formed along lines of fracture or of softer rock which had been previously shifted, or were for any reason not opposite to one another.

That an unfinished plain of marine denudation should have an irregular margin (p. 177) does not prevent our believing that the sea can in time cut back most of the hard promontories as well as the softer rock, or arrest at a uniform level the sub-aërial action, which is reducing both hard and soft. That a river should deposit sediment on a slope at any part of its course, even out into the estuary (p. 187), seems to present fewer difficulties than the supposition that the rock débris resulting from the denudation of Loch Lomond was carried out through a hole in the bottom of the lake (p. 215).

Although, however, such statements lead us to distrust somewhat the author's judgment, we must allow that the work contains much that is useful and suggestive, and should be read by all who are engaged in the study of earth-structure.

#### OUR BOOK SHELF

*The Cone and its Sections treated Geometrically.* By S. A. Renshaw. Pp. 148. (London: Hamilton, Adams, and Co., 1875.)

"WHAT so intricate and pleasing withal, as to peruse and practise Apollonius's Conics?" The author of the present work has evidently the same admiration for this Old World writer that Burton had. He remarks of him that his work has apparently maintained its superiority over every subsequent treatise on the subject. Like Apollonius in one respect, Mr. Renshaw derives the sections from the Scalene Cone, and rebuts the possible charge of "considerable prolixity" by affirming his belief that "the reader will be well repaid for the time and patience expended in the investigation." Upon this point opinions will most likely differ. The subject, though of considerable interest to all minds of a geometrical cast, is yet only a subordinate one, and we question if many can find time in these days of "high pressure" for the extra time and patience demanded. However, the student need not so occupy

his time, for our author has also derived the principal well-known properties from the right cone independently. Further, he establishes a proposition by means of which the scalene-cone properties may be derived from the right cone.

We have, in former numbers of NATURE, given in our adhesion to the principle of deriving the properties of these curves from the cone, and so are glad to see that the latest work on the subject is grounded on this principle. Robertson (1802), following Hamilton (1758), takes as his fundamental proposition the following:—If there be four lines in the plane of a conic which are parallel, two and two, then the ratio of the rectangles under the segments from one point of section to the rectangles under the segments from the other point of section is constant. Mr. Renshaw builds upon the proposition that in the ellipse and the hyperbola the tangent at any point on the curve makes equal angles with the focal distances of the point (with modification for the special case of the parabola). These and the other primary properties are, as we have said, proved from the cone, and this "it is believed to a greater extent than in any previous treatise." A great portion of the work, however, is taken up with the treatment of the curves *in plano*, and here a fundamental proposition is that of the generating circle. The properties are neatly derived by this means. We should mention that the generating circle (which in a particular case becomes the auxiliary circle of modern treatises) is said to have been first employed in Walker's work on Conics (1794), and is thus defined: If we have a focus and corresponding directrix of a conic, and in the same plane take any point and from it fall a perpendicular on the directrix, then the circle required is that described from the above point as centre with a radius equal  $e$  times the above perpendicular ( $e$  being the eccentricity of the curve). We have been thus explicit, as this circle appears to have dropped out of recent text-books. We must refer for application to the work under review. The subject is ably treated, and the book copiously illustrated by well-drawn figures (in most cases); these latter, however, have been sadly marred in the engraving. Indeed, it is matter of regret that the paper, the ink, and the engraving are of an inferior character. The work was printed at Nottingham.

*A Whaling Cruise to Baffin's Bay and the Gulf of Boothia.* By A. H. Markham, F.R.G.S., Commander R.N. With an Introduction by Rear-Admiral Osborn, C.B., F.R.S. Second Edition. (London: Sampson Low and Co., 1875.)

COMMANDER MARKHAM has done well to issue a cheap edition of his attractive narrative at the present time. The author, in the summer of 1873, went out to Baffin's Bay in the whaler *Arctic*, with the deliberate intention of acquiring experience in ice-navigation; consequently from his book a reader is likely to obtain a better idea of the real nature of the dangers attendant on pushing through the frozen ocean, than from a book whose chief aim is to narrate discoveries. Commander Markham, it is evident from the work before us, took such excellent advantage of the opportunities afforded him while cruising about in the *Arctic* seeking for whales, and finding them plentifully, that his knowledge of the "ways" of the ice must be of great advantage to the expedition of which he is second in command.

To those who wish to have a full and accurate idea of how the whale-fishing is prosecuted at the present day, we recommend this delightful narrative, which we should think is likely to become an established favourite with boys. There is a wonderful amount of information packed into the small volume concerning the regions visited, the nature of the ice and icebergs, currents, coasts, natives, fauna, flora, &c. He visited some of the spots rendered classical by former explorers, and actually

corrected the delineation of part of the coast-line in Prince Regent's Inlet. Altogether the book is full of instruction and healthy entertainment; the map and illustrations add to its value in both respects.

LETTERS TO THE EDITOR

[The Editor does not hold himself responsible for opinions expressed by his correspondents. Neither can he undertake to return, or to correspond with the writers of, rejected manuscripts. No notice is taken of anonymous communications.]

Antares

IN reference to the apparent change in the angle of the companion to a Scorpii as shown by the recent measures of Mr. Wilson (NATURE, vol. xi, p. 274), an arrangement of the following, which, so far as I am aware, are all the measures that have been made of this beautiful pair since its discovery by Mitchell in 1845, may prove interesting. From a comparison of these earlier results it is evident that no sensible variation has taken place; and it is probable that in the last, either a slight error has been made in reading the position circle, or the observation was taken under too unfavourable conditions to admit of a high degree of accuracy. The details of these measures will be found in the several publications mentioned below.\*

1. Mitchell ... ..	1846.7	P = $\frac{0}{0}$	D = $\frac{2.51}{0}$
2. Dawes ... ..	1848.0	273.2	3.46
3. Bond ... ..	1848.3	275.3	3.8
4. Müller ... ..	1849.7	276.2	3.69
5. Pöwler ... ..	1855.7	274.6	—
6. Secchi ... ..	1856.4	273.5	3.00
7. Jacob ... ..	1857.2	275.1	3.44
8. Wrottesley ... ..	1858.3	275.9	3.30
9. Powell ... ..	1861.1	271.9	—
10. Dawes ... ..	1864.4	275.7	3.67
11. Dembowski ... ..	1865.6	270.4	2.90
12. Secchi ... ..	1866.0	272.9	2.92
13. Wilson ... ..	1873.4	268.7	3.46

Dawes, in connection with his last measures, says, "there is very little, if any, ground for supposing change has occurred in this splendid but difficult object." The difficulty of seeing the small star in this latitude, as in the case of Sirius and its companion, arises not from its closeness or faintness, but from atmospheric causes due to its southern declination. Mitchell called the small star 11.12 magnitude, but Dawes, Secchi, and others rate it at about 8 m., which is more nearly what it appears to be at the present time. With a very steady air I have several times seen it perfectly with a 6-inch Clark refractor contracted to 33 inch, and on one or two occasions with 34 inch.

Chicago, March 2

S. W. BURNHAM

Storm Warnings from the United States

ALLUSION has recently been made in NATURE to a proposal for the transmission of weather telegrams from the United States to Europe, as likely to afford valuable data for forecasting the weather on our coasts. Some misconception appears to me to attach to this subject.

Having worked for a considerable time at the comparison of United States with European weather charts and reports, I would express my opinion that the project referred to would be undesirable, on the following grounds:—

1. Only a small proportion of the storms experienced on the American side of the Atlantic can subsequently be distinctly traced in Europe at all.
2. Of those thus traceable, the majority are felt severely only in the extreme north of Europe, and are not productive of serious results on the coasts of Great Britain, France, or Denmark.

\* 1. Sidereal Messenger, Sept. 1846.  
 2. Memoirs of the R.A.S., vol. xxxv.  
 3. Communicated to Dawes.  
 4. Memoirs of the R.A.S., vol. xxxii.  
 5. Memorie dell' Osservatorio del Collegio Romano, 1859.  
 7. Memoirs of the R.A.S., vol. xxxvii.  
 8. Memoirs of the R.A.S., vol. xxxix.  
 9. Memoirs of the R.A.S., vol. xxxiii.  
 10. Memoirs of the R.A.S., vol. xxxv.  
 11. Astronomische Nachrichten, 1374.  
 12. Astronomische Nachrichten, 1614.

3. The rapidity of their progress varies indefinitely, and could not be deduced, *pace* Mr. Draper, from the velocity of the currents experienced in them, even if the latter were not variable also.

4. Many of our most destructive European storms occur when pressures over the Eastern States are tolerably high and steady, and appear to be developed on the Atlantic near the eastern limits of the area of high pressure. In such instances attention to the telegrams would in all probability mislead (at least until the relations of areas of high pressures to those of low pressures be better understood), and thus lead to unfortunate consequences.

For these reasons I believe that the utility of a system of weather telegrams from North America to Europe would be by no means commensurate with the serious expense involved in it.

The connection between the weather periods on this and on the other side of the Atlantic is one of the problems which the progress of research is steadily, though slowly, attacking. But such research can be carried on without embarking on a system of weather telegraphy which is unlikely to be practically beneficial, and the failure of which might rather tend to bring this branch of the science into disrepute.

W. CLEMENT LEY

Ashby Parva, Lutterworth, March 12

Meteorological Observations in the Pacific

IN the leader on "Meteorology—Present and Future" which appeared in NATURE, vol. x, p. 99, it is said: "In order to complete the preliminary meteorological survey of the earth's atmosphere and surface it is indispensable that measures be taken to obtain observations from the less frequented regions of the ocean, from Arctic and Antarctic regions, large portions of British America, South America, Africa, and Polynesia." It is also very correctly observed that "in working out the great question of local climates it is absolutely indispensable that uniformity as regards instruments and methods of observation be secured at the different stations."

The meteorology of the Pacific has often occupied my attention, and I have regretted that no systematic effort was made to secure regular observations upon some uniform plan throughout the islands occupied by missionaries. The principal islands in Eastern, Central, and Western Polynesia (as far as the New Hebrides) have gentlemen residing on them, many of whom would (I have good reason to believe) be willing to render assistance in this work. Indeed, many of them are accustomed, already, to make more or less meteorological observations, so far as the reading of the barometer and thermometer goes. But these observations, if collected, would at present be comparatively useless, owing to the want of "uniformity as regards instruments and methods of observation."

Should measures be taken to secure such observations as those suggested in the article above mentioned, and should means be found for supplying (say lending, under certain conditions) instruments to those who are willing to become observers, I believe the co-operation of missionaries in most, if not all, of the following islands may be secured, viz., Society Islands, Hervey or Cook's Islands, Niue or Savage Island, Friendly or Tongan Islands, Samoa or Navigators' Islands, Fiji Islands, Loyalty Islands, the New Hebrides, and the south-east peninsula of New Guinea.

I shall be happy to do what I can to bring about such a result. I am willing to correspond with any gentleman representing the "Central Department," or with the secretary of any society which may undertake the work, with regard to details.

Upolu, Samoa, Nov. 16, 1874

S. J. WHITMEE

Struck by Lightning

THE following is offered you for publication in the hope that the facts were observed accurately enough to be of value, and in the belief that reliable accounts of similar experiences are rare.

The house, in which with my family I have spent the winter, stands in the centre of Torbay and close to the sea. In the garden, which gives access to the shore, is a flagstaff (once belonging to the Coast Guard) 50 feet high, with a metal vane at the top, and having the mast steepled at about 25 feet from the ground in the usual way with iron wire guys. About a foot above ground each wire rope terminates in a 4-inch chain which is anchored a few feet in the soil. These chains are much

corroded, their original diameter being reduced here and there to  $\frac{1}{4}$  inch.

February 25th was a rainy day during the forenoon, with heavy wind from the south-east, but in the afternoon the sky cleared. There had been no sign of thunder all day. At 5 P.M. my wife, my son, and myself were standing under the flagstaff and within 10 feet of a mooring chain, watching the bay, when the vane was suddenly struck by lightning, which broke the mast short off in two places, tearing and splitting the wood between the vane and the iron guy ropes. Through these the discharge then passed to the ground, but three out of the four mooring chains were broken. Not only one, but many links in each of these chains were snapped, both above and below ground, and several of the links were broken in two places at once. The fractures were crystalline and showed no signs of heat. On the garden path, and within a yard of myself, stood an iron roller, towards which the discharge ploughed two shallow furrows in the gravel; one of these is 8 feet long and terminates in a splash of gravel upon the roller.

The broken mast and vane fell to the ground close to us. The former was blackened from end to end around half its circumference, and the edges of the discoloration form ragged splashes. The brass tube forming the vane was ripped open, and all solder about the vane melted. Below the point where the wire ropes were attached to it the mast was uninjured. Shivered fragments of the staff were found on the ground as far as 150 feet to windward. Heavy hail followed the flash, the wind falling instantly to a dead calm; a second but distant flash was seen twenty minutes later, after which there was no more lightning. The discharge startled the whole village of Paignton; the coast guard officer compares the explosion to that of a 300-pounder gun; and at Torquay, 3 $\frac{1}{2}$  miles distant, a scientific friend speaks of both flash and crash as most terrific.

I must now attempt to describe the effects on ourselves and the impressions on our senses, though I am conscious of difficulty in avoiding subjective matter here. Of the three, my wife only was "struck," and fell to the ground, my son and myself remaining erect, and all three retaining consciousness. For more than half an hour my wife lost the use of her lower limbs and left hand, both of which became rigid. From the feet to the knees she was splashed with rose-coloured tree-like marks, branching upwards, while a large tree-like mark, with six principal branches diverging from a common centre, thirteen inches in its largest diameter, and bright rose red, covered the body. None of us are certain of having seen the flash, and my wife is sure she saw nothing. As to the noise, my wife heard a "bellowing" sound and a "squish," recalling fireworks; my son also heard a "bellow," while I seemed conscious of a sharp explosion. My wife describes her feeling as that of "dying away gently into darkness," and being roused by a tremendous blow on the body, where the chief mark was afterwards found. My son and myself were conscious of a sudden and terrific general disturbance, and he affirms that he received a severe and distinctly electrical shock in both legs. My left arm, shoulder, and throat especially suffered violent disturbance, but I did not think it was electrical. As I turned to help my wife, who was on the ground, I shouted, as I thought, that I was unhurt, and hoped they were also, but it seems I only uttered inarticulate sounds, and my son, in his first attempt to answer, did the same. This, however, was only momentary; in an instant we both spoke plainly.

Neither of us referred the occurrence immediately to its true cause, but the idea of being fired at was present to all our minds, my wife indeed remained of opinion that she was shot through the body, until she heard me speak of lightning. An infinitesimal lapse of time enabled my son and myself to recognise lightning; but I cannot say whether I did so before or after my first glimpse of the wreck on the ground. Neither of us heard or saw the mast fall, though it descended fifty feet, and fell on hard gravel close to us. My son and myself both experienced a momentary feeling of intense anger against some "person or persons unknown," further showing that we primarily referred the shock to some conscious agency. I ought perhaps to add, that neither of us felt any sensation of fear at the time; but we were all very nervous for several days after.

I have endeavoured to keep to fact throughout, but I venture to add a remark made by my wife as we raised her from the ground: "I feel quite sure that death from lightning must be absolutely painless;" and I offer it as an unconscious corroboration of views on this subject which our experience seems to strengthen.

Though no electrician, I conclude from the splash of gravel on the garden roller that the discharge was from cloud to earth, and the oxidised mooring-chains being inadequate to carry it all to ground, my wife formed a conductor for one of many sprays flying in all directions from the broken links.

Paignton, March 10

D. PIDGEON

#### Mr. G. Darwin's Paper on Cousin Marriages

THE report in the *Times* of my paper on Cousin Marriages, read before the Statistical Society on Tuesday, the 16th inst., contains an important error. It is there made to appear that out of 8,170 lunatics and idiots in England and Wales, 4,308 were offspring of first cousins. This should have run:—Answers with respect to the parentage of 4,308 out of the 8,170 patients were obtained; 142 to 149 of these were stated to be offspring of first cousins, that is to say, nearly 3 $\frac{1}{2}$  per cent. Similarly, out of 514 patients in Scotland, 51 per cent. were found to be offspring of first cousins.

I had hoped that the monstrous nature of the mistake would have shown it to be a misreport; but although the error was pointed out in the next day's *Times*, I have already had my attention drawn to it several times, and you would therefore be conferring a great favour on me by giving further publicity to the correction in your columns.

GEORGE DARWIN

Down, March 21

#### Mounting Acari for the Microscope

I HAVE much pleasure in detailing, for the benefit of your correspondent Mr. R. C. Fisher, a method I practised extensively some years since, and with the best possible results, in preparing Acari for the cabinet. The section then occupying my attention was the group of the *Hydrachnidae*, or "Water Mites," and to illustrate which I possess some hundred slides representing twenty or thirty species in various conditions of development. In first attempting to preserve these as permanent objects for the microscope I encountered difficulties similar to those of Mr. Fisher; the little animals being hard to kill, and their limbs in death doubling beneath to the great detriment of their personal appearance. As an experiment, I tried immersing them in boiling water, and was rewarded by finding this treatment to achieve everything that could be desired, death being instantaneous, and with the limbs rigidly extended in perfect symmetry. This method proved equally efficacious with various earth mites, such as *Trombidium*. A watch-glass, spirit lamp, and camel's hair brush is all the apparatus necessary. The occupation of other and larger "fish to fry" has unfortunately prevented my prosecuting the study of this most interesting group of the Arachnida so far as I first proposed.

Manchester Aquarium

W. SAVILLE-KENT

#### The "Wolf" in the Violoncello

CAN any of your readers explain the reason of the unpleasant jarring noise which is sometimes found in certain notes of the violoncello, termed by musicians the *wolf*?

In an instrument in my possession the *wolf* exists on one note only, viz., the F of the bass clef (). This is not due to a defect in the string, as the same note stopped on the G string still produces the *wolf*.

It seems, therefore, that from some defect in the instrument itself, it is unable to vibrate in conjunction with a string having a certain rate of vibration, though it will take up the vibrations of every other but this particular note.

HERBERT F. FRYER

#### Coloured Shadows

SIX Grove's cells were connected with one of Ladd's large induction coils, and the secondary current, condensed by two Luge Leyden jars, was sent, in the usual way, between two pairs of metallic electrodes, in order to examine their spark spectra.

Two of the electrodes were of platinum: these may be called pair A.

Of the other pair, B, one electrode was of platinum, and the other of the metal to be examined.

Place a piece of white paper equidistant from, and on one side of, the two sparks. Hold the finger so that a shadow of it may



be cast by each spark. The two shadows will be seen to be most beautifully tinted with different delicate colours, varying according to the metal inserted in B.

It will be seen that the shadow thrown by A is lighted by B, and is seen on a ground jointly illuminated by A and B; whilst B's shadow, lighted by A, is seen on the same common coloured ground as before.

Without these considerations, it might have been supposed that the shadow thrown by B, and lighted by the unchanging spark A, would itself have remained unaltered. I saw it of the colours, pink, light pink, dim pink, light green, nearly white, and yellow-green; corresponding to the introduction into B of Bi, Ag, Sn, In, Al, and Mg respectively.

I was indebted for the apparatus to Prof. Liveing, in whose laboratory last November, at Cambridge, I made these observations.

C. T. L. WHITMELL

Nottingham, March 16

### OUR ASTRONOMICAL COLUMN

**ANTHELM'S STAR of 1670 (II VULPECULÆ).**—In the catalogue of stars observed at the Royal Observatory, Greenwich, in the year 1872, in the volume lately circulated, will be found the position of the small star near the place of Antheim's star of 1670, which was for some time of the third magnitude. It is No. 816 in the above-named catalogue, and for 1875<sup>o</sup> its R.A. is 19h. 42m. 32s.78", and N.P.D. 62° 59' 15".4. This is only about one minute of arc from the place given by Picard's observations published in Lemonnier's "Histoire Céleste," and there is an uncertainty in the R.A. deduced from those observations amounting to one or two seconds of time. The star deserves attention, and the more so as there has been a suspicion of sensible variation about an average minimum for some years past. It may be advantageously compared with a star of pretty nearly the same magnitude following 12s.5 in R.A., and 4'9" to the north, and also with one which follows 22s.5, about 0'7" to the north. Occasional slight variations are perceptible in Nova (Ophiuchi), 1848, usually of 12<sup>o</sup>13 magnitude, and, according to Schönfeld's observations in Nova (Coronæ), 1866, also, as we have lately stated, in the star close upon the position of Nova (Cassiopeæ), 1572. We follow the example of the Manheim astronomer in applying the term Nova to these objects, though it would probably be more correct in each case to consider them as belonging to a class of irregular variables of great extremes of brightness. Mr. Tebbutt, of Windsor, N.S.W., was satisfied from his own observations that η Argūs had been "alternately above and below a mean magnitude" for several years previous to 1870.

**METEOR-SHOWER of OCTOBER A.D. 855.**—This shower of meteors does not fall in with the thirty-three year period indicated by Prof. H. A. Newton; but from the description in "Annales Fuldenses," it was evidently one of similar character, and indicated a great accumulation of meteors in a part of their orbit far distant from the mass encountered by the earth in 1799, 1833, and 1866. We read: "Mense vero Octobris xvj. Kal. Novemb. (i.e. October 17, O. S.), per totam noctem igniculi, instar spiculorum, occidentem versus per aerem densissime ferebantur." It was from a comparison of this date with that of the great display in 1366, witnessed in Bohemia and in Portugal, that Boguslawski suspected an advance in the nodes of the meteor-orbit at a time when its real form had not been detected. Quetelet, in his "Nouveau Catalogue des Principales Apparitions des Etoiles Filantes," refers to an Arabic account of the same shower (855), and on the same date, Oct. 17, in the following year, he mentions the occurrence "des feux semblables à des points parcourant le ciel pendant toute la nuit," but the authority of a chronicler whose history is found in Bouquet's Collection; suspecting, however, its identity with the shower recorded by the Fulda annalist. We know that there are recent cases of considerable numbers of meteors on or

about November 12, which are also divergent from the thirty-three year period for maximum, as on Nov. 12, 1820 and 1822; but the shower of October 17, 855, appears a remarkable instance. The dense stream towards the west brings to recollection the grand display of November 1866.

**COMET 1840, III.**—This comet, discovered by Dr. Galle, at Berlin, on March 6, and observed at Pulkova till the 27th of the same month, affords a curious instance where one of these bodies, after apparently encountering the powerful influence of the planet Jupiter, has presented itself in these parts of space moving in an orbit which is undistinguishable from a parabola. Definitive elements have been lately calculated by Kowalczyk and Doberck, and if we trace the path backward thereby, to the beginning of 1839, we find the distance between the comet and planet about January 20 would be less than a third of our mean distance from the sun. It is true the interval over which the observations extend is only three weeks, but the residual errors of the parabola are so very small, that it is evident no very sensible ellipticity was produced by the near approach to Jupiter, as would appear to have been the case with many other comets. There is a suspicion that something similar took place with the third comet of 1759, which passed so near the earth in January 1760, but the elements of that body may perhaps admit of better determination. Lacaille's orbit shows a pretty close approach to Jupiter on the comet's journey towards the sun, a circumstance first referred to by Pingré.

### THE BIRDS OF BORNEO \*

**T**HE fifth volume of the annals of the "Museo Civico" of Genoa (for the establishment of which science is indebted to the liberality and exertions of the Marchese Giacomo Doria) is devoted to an elaborate memoir on the birds of Borneo, prepared by the well-known ornithologist, Tommaso Salvadori, of the Museum of Turin. The work is based upon the rich collections made by Doria and his companion, Dr. Beccari, during a scientific expedition to Borneo in 1865 and the following years. Whilst the latter naturalist devoted himself principally to plants, and obtained an enormous series of them which has enriched many of the herbaria of Europe, the former occupied himself in general zoological collections. Among the results of his activity were upwards of eight hundred specimens of birds, obtained chiefly near Kutchin, the capital of Sarawak, which was the head-quarters of the travellers. Dr. Salvadori having had this fine collection placed in his hands for examination, thought the opportunity was favourable for attempting a complete account of the birds hitherto known to have been obtained in Borneo, on which, up to the present time, there has been no authority. In the present memoir we have the results of his labours, forming altogether a volume of 430 pages.

Considering the large extent of the island of Borneo, the published works of naturalists upon its fauna are few, and a large portion of its varied surface remains still unexplored. As regards its ornithology, we are indebted to the naturalists formerly employed by the Dutch National Museum at Leyden for the greater part of our knowledge. Schwaner, Diard, Salomon Müller, and others, made rich collections in the territories of Pontianak and Banjarmassing, fifty years ago, and supplied many of the types figured by Temminck in his "Planches Colorées." Our Mr. Wallace was the first ornithological explorer of Sarawak, but never published any complete account of his collections made there. Another English naturalist, James Motley, also made several collections in the island of Labuan and in Banjarmassing. These were partly described in 1855, in a work commenced by Mr. Motley

\* "Catalogo sistematico degli uccelli di Borneo," di Tommaso Salvadori con note ed osservazioni di G. Doria ed D. Beccari, intorno alle specie da essi raccolte nel Ragajo di Sarawak.

in conjunction with Mr. Dillwyn. But Mr. Mottley's untimely death in the Malay insurrection of 1860 put a stop to the publication, though his Banjer-massing collection was subsequently catalogued by Mr. Sclater in the Zoological Society's "Proceedings."

From these and various other authorities, of which a complete account is given in the introduction to the work, and from the study of Doria's numerous series, Dr. Salvadori has compiled his list of 392 species of Bornean birds. Their synonymy is very fully stated, and the localities are completely given, whilst descriptions and remarks of various characters are added when necessary. Of the 392 species of Bornean birds, fifty-eight, Dr. Salvadori tells us, are peculiar to the island, whilst the remainder are found also in Malacca and Sumatra, or have a still wider distribution. With these last-named countries it is, as already pointed out by Lord Walden,\* that Borneo has a most intimate relation, upwards of 250 species being common to these three localities. These and many other facts relating to the ornithology of Borneo are well put together by our author in this excellent memoir, on which it is obvious great labour has been bestowed. The volume is rendered still more complete by an outline map of Borneo and the adjacent islands, and by several coloured plates of the rarer species of birds, amongst which the extraordinary shrike-like form called *Pityriasis gymnocephala* forms a conspicuous object. Dr. Salvadori's work is thus an indispensable addition to a naturalist's library.

#### PHENOLOGICAL PHENOMENA †

UNDER the title given below a pamphlet has just been issued containing instructions for the correct observation of the first appearance of insects, birds, and plants in flower in any locality. We recommend it to the attention of all who have opportunities of making such observations, and there are thousands who have. If a host of observers could be enlisted in this work, and if they adhered faithfully to the instructions given in the pamphlet, they would not only find a new source of real pleasure and instruction, but would certainly make large contributions to our knowledge of natural history.

A list is given of ninety-seven plants, insects, and birds to be observed, with a set of general rules, approximate phenological dates, and special remarks and suggestions in connection with the various divisions. Those in botany are drawn up by the Rev. T. A. Preston, F.M.S.; in entomology, by Mr. R. McLachlan, F.L.S.; and in ornithology, by Prof. A. Newton, F.R.S. Each of them presents a series of notes on various individual plants and animals, and Prof. Newton has some general remarks in his own department, from which we make the following extracts:—

"It constantly happens, especially among the earlier birds of passage in spring, that they will for some days haunt one particular spot before appearing in others or generally throughout the district. I myself knew a particular reach of a river which was yearly frequented by the Sand-Martin for nearly a week or ten days before examples of that species were to be seen elsewhere in the vicinity. I also knew a parish in which the Chiffchaff always bred, but not for a month or six weeks after it had arrived in many of the neighbouring parishes was its note to be heard within the limits of that particular parish. I could easily cite other cases of like nature, but many if not most observers of birds from their own experience will bear me out in this. It follows, therefore, that to render the proposed observations trustworthy, an

observer of any fact connected with birds should set down the exact locality at which it occurred, even if it be but a few miles' distance from his own station, and if possible again record the fact when it recurs there; or *vice versa*. Otherwise there will naturally be a risk of considerable error, but an attentive observer will probably soon come to find out the localities in his neighbourhood which are first visited by any particular kind of bird, and after a few years' experience the double observation will very likely prove unnecessary."

After giving some notes on a number of individual birds, Prof. Newton goes on:—

"Nearly all the observations above suggested can be made or collected by most residents in the country generally, and even by some who live in towns; but such observers as dwell at or near the seaside—and especially not far from the stations chosen by various sea-fowls for their breeding quarters—are recommended to keep watch for their arrival and departure. It has been frequently asserted that many of these birds, as the Guillemot, Puffin, Razorbill, and certain Gulls, resort to and quit their stations punctually on a particular day, regardless of the state of the weather; and if such statements are correct, the facts which render the birds independent of meteorological conditions seem to deserve attention. In some cases the assistance of lighthouse-keepers, if sought, would probably conduce to the success of the inquiry, as they almost always take an interest in the doings of their feathered neighbours. Lighthouse-keepers, it is believed, could also furnish valuable information as to the extraordinary flocks of migrant birds which occur by night at uncertain intervals. These flocks consist of a very heterogeneous assemblage, and it is seldom that the particular kinds can be identified except by the victims that may be found next morning lying dead beneath the glasses against which they have dashed themselves. Similar flocks are occasionally observed inland, and chiefly over or near large towns, whither it may be supposed they have been attracted by the glare of the street lamps. In these latter cases it is seldom that examples are procured to show of what species the flock was composed, but the mere fact of its occurrence is always worthy of record, with the precise hour at which the birds were heard, in a weather report. The cries, whistling, and screams of the birds, sometimes even the sound of their wings, are often enough to attract the attention of the most unobservant; and, as far as I know, these miscellaneous flocks only occur on perfectly still pitch-dark nights, with a comparatively high temperature and a falling barometer—circumstances that point to an atmospheric cause of the wonderful concourse.

"A connection between the habits of birds and meteorological conditions is popularly believed to exist in the case of the Green Woodpecker, the frequent cry of which is said to presage rain; but I have failed to find that this is so. The Redbreast, on the other hand, when singing from an elevated perch at evening, is said to be an unfailing prophet of a fine day on the morrow, while if its parting song be uttered from a lower station bad weather is supposed to follow. As far as my own experience goes, the only connection between changes of weather and the habits of birds (omitting of course hard frost and deep snow, the effects of which are obvious) is, that many birds seem to be more alert, or 'wilder,' as the sportsmen say, for a day or two before a heavy downfall; I have observed this with partridges, plovers, and snipes."

We recommend all our readers to procure these "Instructions."

#### INSTITUTION OF NAVAL ARCHITECTS

AT the annual meeting of this Institution last week, three papers of interest to the scientific world were read and discussed. All three of these papers bore upon

\* Ibis, 1872, p. 361.

† Instructions for the Observation of Phenological Phenomena, prepared at the request of the Council of the Meteorological Society by a Conference consisting of Delegates from the following Societies, viz: Royal Agricultural Society, Royal Botanic Society, Royal Dublin Society, Royal Horticultural Society, Marlborough College Natural History Society, Meteorological Society.

the subject of waves, which is at present occupying so much the attention of all those who, both in this country and abroad, are endeavouring, by researches into their forms and habits, to improve the theory of Naval Architecture.

The first paper was on a proposed method of obtaining the outlines of deep-sea waves, by Mr. W. W. Rundell, the secretary of the Liverpool Underwriters' Association. The important part which photography has recently played in the observations on the Transit of Venus, and the assistance which it has thus rendered to astronomy, led Mr. Rundell to consider whether it might not also be employed to determine the forms of waves and so supply data for obtaining their chief components. The application which Mr. Rundell proposes consists of a system of poles about 36 feet in length, painted with alternate bands of red and blue, each band being a foot wide. These poles are spaced 15 feet apart and loosely coupled at one end to yards or spare spars extending to a length of about 600 feet. A similar system of poles intersects the first system at intervals of 90 feet, the different parts being connected together, in moderate weather, while floating on the surface of the water. Weights being attached to the spars would cause the poles to sink until only about 12 feet of their length was visible above the water. Mr. Rundell proposes, by the aid of photography, to take pictures of the outlines of waves seen against this system, the photographs being taken either from the cross-trees of a man-of-war or from some elevated position such as the Fastnet, or Skellig Lighthouses. Mr. Rundell thinks that thus the complete history of a gale might be photographically recorded. Mr. Froude, however, seemed to think that there would be greater difficulties to encounter than Mr. Rundell imagined.

The next paper, by Mr. Froude, was a description of the graphic integration on the equation of a ship's rolling, including the effect of resistance. Mr. Froude first pointed out that the commonly employed methods of graphic integration, *i.e.* the semi-geometrical processes by which the solution of intractable mathematical problems is effected, do not readily lend themselves to the treatment of a problem in which the forces which govern the movements of the body arise afresh at each instant, as the direct and indirect effects of the very movements they are creating, but that his method is perfectly capable of dealing with this circumstance.

The two principal forces taken account of in this method are the ship's "righting force" or "moment" as dependent on her inclination relatively to the wave slope at each instant; taking into consideration any speciality in her curve of stability; and the resistance she experiences while in motion, as dependent on her angular velocity. Taking the equation of rolling motion to be integrated is, in its most complete form, as follows:—

$$-\frac{d^2\theta}{dt^2} = \frac{\pi^2}{T^2} \left\{ f(\theta - \theta') + R \right\}$$

Here  $\theta$  is the ship's absolute inclination,  $\theta'$  the inclination of the wave, and  $\theta - \theta'$  is her inclination relatively to the wave slope, or the ship's "relative inclination;" the term  $f(\theta - \theta')$  signifies that function of the relative inclination which in the curve of stability is assigned to the particular inclination, and expresses the righting moment of the ship when so inclined.

$T$  is the time, in seconds, occupied by the ship in performing a single swing when rolling to moderate angles in still water, being half of what is commonly called the "metacentric period."

$R$  is the effective "moment of resistance" which the ship is at the instant experiencing when rolling with her existing angular velocity, its elementary signification being homogeneous with that in the ship's curve of stability, in which  $f(\theta - \theta')$  stands for the righting moment. In both terms, alike, these elements consist in effect of

"so many foot-tons  $\times \frac{g}{W\rho^3}$ ," where  $W$  is the ship's weight in tons,  $\rho$  her radius of gyration expressed in feet, as  $g$  also usually is. The abstract value of  $R$  is

$$k_1 \frac{d\theta}{dt} + k_2 \frac{d^2\theta}{dt^2}$$

where  $k_1$  and  $k_2$  will have values appropriate to the particular ship in question; and observe that the  $\pm$  sign must be understood to mean that the sign of the second term, which, being a square, would in itself be always positive, must change signs in company with the first term.

A base line being taken to represent time, and divided into equal spaces representing small unit-intervals of time,  $\Delta t$ ,  $\Delta \theta$ , &c., the inclination at each instant, whether of the ship or of the wave, are to be expressed as ordinates to a scale of degrees; those above the base line being positive, and those below it negative. A "curve of wave slopes" being drawn, the ship's absolute inclinations, which grow out of the circumstances, as time (and the varying wave slopes which time brings) proceeds, by Mr. Froude's method of graphic integration, are represented by a curve analogous to the "curve of wave slopes" in general character. This curve which gradually grows out of the integration Mr. Froude calls the "curve of rolling" or the "curve of inclinations." The difference between the ordinates of these two curves, at any instant, gives the ship's relative inclination at that instant on which the righting force depends. The angular velocity of the ship's change of inclination is obviously expressed by the tangential direction of the curve, and this circumstance is of essential importance in the process by which the curve is deduced.

To carry out the process two auxiliary curves have to be introduced:—

1. The "ship's curve of stability," which supplies, as has been explained, her righting moment, as due to her relative inclination at any instant. In this, the base is formed of a scale of angles, this scale being the same as in the "curve of wave slopes" and the "curve of inclinations." The ordinates corresponding with given inclinations express the righting moments at those inclinations to the scale which is employed in the graphic process.

2. The "curve of resistance," which supplies the moment of resistance experienced by the ship when moving with any given angular velocity.

As has been already stated, the conditions are—

$$R = k_1 \frac{d\theta}{dt} + k_2 \frac{d^2\theta}{dt^2}$$

The first of these terms is expressed by a straight line, and the second by a parabola which takes that straight line as its base.

Turning to the employment of these data in the geometrical solution of the dynamical equation, by grouping the force terms under the single symbol  $\phi$ , we may write the equation thus:—

$$d(\Delta\theta) : \Delta t = \phi : \frac{T^2}{\pi^2 \Delta t}$$

Substituting for the differential terms, small quantities virtually infinitesimal—

$$\Delta(\Delta\theta) : \Delta t = \phi : \frac{T^2}{\pi^2 \Delta t}$$

where  $\Delta t$  is the unit of space taken in the curve of wave slopes.

By a simple geometrical contrivance this ratio is utilised by drawing a base line each way from the foot of the vertical axis in the "curve of resistance," which measured by the time scale =  $\frac{T^2}{\pi^2 \Delta t}$ , ending at +P and -P.

Through the end of this line the inclination  $\theta_0$  is set off with a parallel ruler from the "curve of wave slopes." The height  $p$  at which this line cuts the directrix is proportional to the angular velocity.

Now,  $\Delta(\Delta\theta)$ , the difference of inclination which we wish to find, as has been shown,

$$= \Delta t \cdot \phi \frac{\pi^2 \Delta l}{T^2}$$

and  $\phi$  consists of  $f(\theta - \theta') + R$ , of which the former is the ship's righting moment, and the second her moment of resistance.

Thus we can find  $R$  from the angular velocity,  $\theta$  from the "curve of wave slopes," and  $\theta'$  absolutely at the beginning of the first interval and approximately at the end of the subsequent time intervals.

The difference between the exact ordinate length of the two curves at  $t_0$  and approximately estimated length at  $t_1$  is applied by dividers to the line of abscissæ, and hence is obtained the value of  $\theta - \theta'$  and therefore the corresponding ordinate gives  $f(\theta - \theta')$ .

The sum of  $(\theta - \theta')$  and of  $R$  is taken as an ordinate of the "force curve" at each point, and by connecting the tops of these ordinates we have a close approximation to the first segment of the force curve. The ordinate length of  $\phi$  being now obtained, some necessary correction being made, if the line  $P_1\phi$  be now drawn, the difference of its tangential inclination from that of  $P_0\phi$  represents with close approximation (indeed, exactly, if the provisional estimate has been judiciously made) the change of velocity

which has ensued during  $\Delta t_1$ , and a line parallel to  $P_0\phi$  will be the tangent to the curve of inclination at  $t_1$ . Draw, therefore,  $b'b$  as the tangent across the ordinate  $t_1$  at such a height that it shall intersect the previous tangent at the middle part of  $\Delta t_1$ . This height is the first approximate value of the ordinate to the curve of inclinations at that point.

By carrying out this method the whole curve of inclinations is obtained.

This description of Mr. Froude's paper is necessarily very imperfect, through our being obliged to leave out the small corrections, which without figures would be unintelligible. But it is sufficient to show his extremely neat and simple way of drawing a curve which shall determine a ship's absolute inclinations.

The third paper was by Mr. B. Tower, on a method of obtaining motive power from wave motion. He said that this inquiry originated with Mr. Deverell, who came home from the antipodes for the purpose of promulgating it. Mr. Deverell's proposition was to suspend a heavy weight on board a ship by means of springs, and to obtain motive power by the oscillation of this weight through a distance not more than the height of the waves. It however appeared to Mr. Tower that since the centrifugal force of wave motion in a vertical direction is alternately

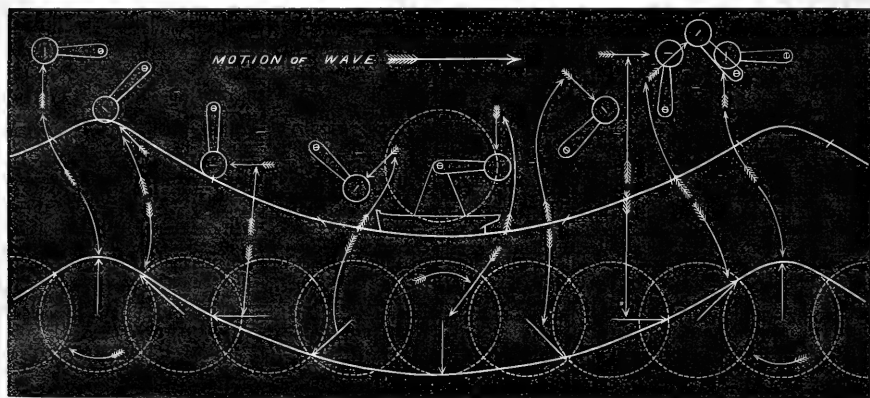

added to and subtracted from, the force of gravity thereby causing a virtual variation of the intensity of that force, the question might be broadly stated as follows:—

Supposing the force of gravity to vary in intensity at regular intervals, that is, to become alternately greater and less than its normal amount, what is the best means to obtain the maximum amount of energy from a given weight oscillating under the influence of these variations? For example, supposing the force of gravity to be for three seconds one-fifth greater, and for the next three seconds one-fifth less than its natural intensity, and suppose that we have a weight of five tons suspended by a spring, with an infinitely open scale, so that the spring will continue to exert a uniform upward force of five tons, no matter how far the weight moves up and down, it is clear that during the three seconds' interval, during which gravity is one-fifth more than its normal intensity, the five-ton weight will virtually weigh six tons, and will thus exceed the upward force of the spring by a downward force of one ton; in the same way, when the force of gravity is one-fifth less, the weight will only weigh four tons, and the spring will then exert an unbalanced upward force of

one ton. Now, as energy or power is defined as force moving through distance, it is clear that the quantity of energy or power to be obtained by this system will depend on the distance through which this weight is caused to move during each successive variation of gravity. Thus, supposing that during the *plus* interval it moves downwards through one foot, and during the *minus* interval it moves upwards through one foot, it is clear that during each of these intervals it will exert a force of one ton moved through one foot—that is, one foot-ton; but if, instead of one foot, it moves through ten feet, it will exert ten times the power—that is, ten foot-tons; or if it moved through 100 feet, it would exert 100 foot-tons during each interval of three seconds.

The first experiments Mr. Tower made with a model apparatus constructed on these principles showed him that the best arrangement would be to put a weight on the end of a revolving arm, whereby the centrifugal force of the wave motion might be utilised as well as the rising and falling motion.

The diagram shows the position of the vessel and of its revolving arm at all parts of a wave; the arrows show

the direction of the centrifugal force of the wave motion according to the generally received theory. This force is upwards at the crests, downwards in the hollows, and horizontal midway between the crests and hollows. If the weighted arm is compelled to assume successive angular positions, so that it is always at right angles to the force, it is evident that the force will be continually acting to cause the arm to rotate. It is easy to see how the work is taken out of the waves, for when the vessel is descending, the weight is performing the upper half of its revolution, and is consequently exerting an upward centrifugal force; and when the vessel is ascending, the centrifugal force is pushing down and resisting the vessel's ascent, so that the revolving weight affords a resistance against which the vessel can push just as if it were a fixed point in space. The shaft of the revolving weight can be made to turn a screw in the stern of the vessel by means of a proper system of gearing, and by a delicate arrangement of electric brakes and hydraulic accumulators, Mr. Tower proposes to regulate the revolving arm so as always to keep it at right angles to the centrifugal force of the waves.

#### THE FARADAY LECTURE

LAST Thursday, as our readers know, Dr. A. W. Hofmann, of Berlin, delivered at the Royal Institution the Faraday Lecture of the Chemical Society, his subject being "Liebig's Contributions to Experimental Chemistry." The audience included the Prince of Wales. Dr. Odling occupied the chair. The dinner on Friday at Willis's Rooms was probably one of the most remarkable scientific dinners that have taken place for some years, there being about 180 present, nearly all of them well-known men of science. Dr. Hofmann made a noble appeal on behalf of the recognition of the high value of pure scientific research; and Prof. Huxley acknowledged the while in scientific ideas we might be abreast of the Germans, yet the latter undoubtedly excelled us in the amount of their scientific work.

Dr. Hofmann in his lecture began by pointing out that Faraday belonged by the universality of his genius to all civilised countries, and the council of the Chemical Society had ordained that all countries should be asked to join in rendering homage to the greatest experimental thinker among mankind. On the present occasion Germany had been invited to take part in this international tribute, and it was a great honour for him to interpret his country's homage. His illustrious teacher and lamented friend Justus von Liebig was a master mind like Faraday, and Liebig's is the name and figure alone fitted to stand on equal terms beside Faraday. But to speak of Liebig only we must proclaim him one of the greatest contributors to chemistry at large, while of organic chemistry he was the founder. It is not only by the discovery of new facts that he was distinguished, but by the conception of general laws which illustrate both organic and inorganic chemistry. By the great types of composition which under the name of "radicles" he first spoke of, and by the researches to which these led, he guided not only his contemporaries, but will guide succeeding ages. He was also the first to found in Europe the great system of practical education. It was at Giessen he organised the first great laboratory of experimental instruction; and if we now admire magnificent temples of science, let us not forget that we owe them to him as their originator. He called around him distinguished students, many of whom were raised now to exalted positions by their talents and learning, and many of whom the lecturer saw before him; they would not be wanting in the tribute of heartfelt reverence to their great master. By his keen insight into chemical analogy he marked out the way of chemical research, and he also

showed how to keep up the supply of human hearts and minds to prosecute his work. He provided arms, and soldiers to wield them.

There is no greater proof of the fecundity of genius than that it enriches the storehouse of science with its discoveries, and at the same time provides the means of ulterior conquest in ages yet to come. Which of us returning to-morrow to his lonely post in the laboratory could not feel cheered by the example of such men as Liebig and Faraday? It was the habit of Liebig to trace laws in their furthest results, and their applicability to promoting the practical welfare of mankind. No one has in this way more enriched us. Liebig's labours in abstract science bore fruit in the useful arts. He materially elucidated great industries, the manufacture of fulminating compounds and prussiate of potash, for instance, together with materials of the most important use in the manufacture of the precious metals, and silver-coated mirrors, so preferable for purposes of science and adornment to the old mercury-backed glasses. *Illustrans annuata vitæ*, he never let slip any occasion of promoting the good of his fellow-creatures. His penetrating philosophy could not remain a stranger to the profound secrets of life based upon chemical change. He revealed the dependence of plants upon the chemical composition of the soil and air. He studied also the laws of nutrition and development of the animal body. In the former of these branches he was crowned with the greatest success. He began in 1840 by his work on agriculture and zoology, written in compliance with the request of the British Association at their 1837 meeting at Liverpool, and he followed it up by his work on husbandry. His labours resulted in the establishment of the philosophy of agriculture, and ranked him with Lavoisier, who showed in the last century how the vegetable stands between the mineral and the animal, and collects from the former world food for the latter. Lavoisier was followed by Humphry Davy, and after him came Liebig. They are the three great lawgivers of modern agriculture.

It was in 1842 that Liebig, passing onward from food-producers to animals, brought out his work on the subject, and it may be taken as a result of his work that the superabundant animal food of thinly-peopled parts of the earth has been, by a fast developing industry, brought over to guard Europe against the pinch of want. Those who are engaged in the curative art must bear him gratitude for the discovery of chloroform; nor will they forget chloral, the benign influences of which will even induce sleep, and rank it among the most sublime agencies placed at the disposal of therapeutics by chemical art.

He had, the lecturer said, selected but a few illustrations, which would give them a better idea than any long explanations by him of Liebig's voluminous life-work, and he asked them to accompany him in a rapid view of Liebig's memorable contributions to chemistry proper. But Liebig's contributions to the Royal Society's library were, in 1863, 317 in number, and 283 were entirely by himself. When the lecturer's pupils in Berlin heard that he had been entrusted with this lecture, they produced all the substances which Liebig at any period of his career more particularly illustrated; these preparations now crowded the table.

The first achievement he would allude to was that which, whether or not his most brilliant discovery, contributed most to facilitate the labours of chemists, and was the main source of the marvellous development of organic chemistry—analysis by combustion of organic bodies and the determination of their carbon by his form of measurement. Not one there but had determined the molecular weight of bodies, but they might not be aware that we are indebted for the process to Liebig. He never published any particular paper on the subject, but merely communicated his method in a paper on another chemist's researches. Its merit is simplicity, like that of his air analysis. That an alkaline solution of pyrogenic acid

takes up oxygen and becomes more and more blackened by its action had long been known. But it was reserved for Liebig to found on the fact the measurement of oxygen. By treating the gas to be examined first with potash and then with pyrogenic acid, he combined the investigation for oxygen with that of carbonic acid.

Passing to the researches he effected by the instrumentality of his inventions, there came the fulminating compounds. At a remote period Liebig compared fulminic with picric acid. There was no satisfactory analysis of the method of fusing substances with prussiate of potash, and he first showed how iron is taken up by ferrocyanides, and his experiments are the foundation of the modern manufacture. Another valuable point was his simple process of obtaining cyanide of potassium. It is now manufactured on a large scale on his process, and is thus extensively used in electrotyping. This discovery led him to others. Liebig and Wöhler furnish us with the group of aromatic compounds which stream forth from benzol in infinite variety. At the conclusion of the description of their experiments they say their inquiries arrange themselves round a group of acids. This analogy induced them to consider the group as a kind of compound element, to which they gave the name of benzol.

When a chemist is fortunate enough to encounter some such guide in the midst of unknown nature, he has good cause to congratulate himself. If even now after forty years the results of this research have such fascination, what were the feelings of contemporaries? One of them "discerns the dawn of a new day," and suggests or thine for the name of the new compound element from *ἄρπρος*, "day-break." Now, the lecturer should by rights unfold before their eyes the chain from oil of almonds to benzoic acid. But time reminded him to hasten on. The uric acid group furnished a path which had not yet conducted us to the goal. Uric acid was not all unknown in 1834, when Liebig established its formula. It had been known in 1734, but it was not till 1850 that a youth in his 19th year discovered the most fertile source of the compound; Liebig and Wöhler soon showed that its mutability, its liability to chemical change, entitled them to reap rich harvests from it. Sixteen new and most remarkable bodies were at a single stroke incorporated into the history of chemistry. Only one has since disappeared and called for rectification, and no better proof could be given of their scrupulous accuracy. They showed how clearly they discerned the synthetic direction which organic chemistry was about to take. Sugar, silicine, morphine would be, they say, synthetically prepared. One more illustration must suffice—the remarkable results in the investigation of alcohol. His first experiments were in 1832, when his inquiry, undertaken for purely scientific and abstract ends, led to the discovery of chloral and chloroform. He discovered hydrate of chloral and its beautiful crystalline form. In 1847, fifteen years after its discovery, chloroform was used for the first time as an anæsthetic, and twenty years more elapsed before Liebreich found a similar use for chloral. At the present day the chemical factories of Berlin alone produce 100 kilos, a day of the principal anæsthetic.

Liebig denied the presence of the olefant gas previously ascribed to alcohols, and gave their chief constituent the name of ether, and although according to our present view the relation between alcohol and ether has changed, no one now speaks of the olefant theory. The new system of chemical notation introduced by two French chemists was nowhere earlier championed than here, and by Faraday. To that England owes the honour of being foremost to recognise the truth of the new doctrine. Its modification of Liebig's formulæ extends also to his ether. Williamson elucidated the question with striking success, but Williamson owed to Liebig the very agents; he so successfully employed. Liebig "had no doubt we should suc-

ceed in the analysis of ether." Liebig's dream was realised by Frankland.

Our respect and our admiration are due to Liebig not for his scientific labour alone: we learn from him that anxiety to discover abstract laws is not to be dissociated from efforts for the well-being of our race. The lecturer remembered a little incident so illustrative of Liebig's goodness of heart that he ventured to relate it. He then told the story of a broken soldier, whom, during a tour in the Tyrol, Liebig not only helped with florins, but procured quinine for a toilsome walk over mountains. Of Faraday's kindness he had a touching example. A gentleman had handed him a letter of 1834, in which Faraday wrote to a student who had engaged, like many others, in a dream about matter and atoms, and was anxious to submit his ramblings in philosophic dreamland to the greatest chemist of the day. He forwarded it with the suggestion that it was worth while to test it. Overwhelmed, as Faraday then was, with work, he answered not with neglect or with cheap flattery; he wrote to the unknown youth as follows:—

"I have no hesitation in advising you to experiment in support of your views, because, whether you confirm or confute them, good must come out of your experiments. With regard to the views themselves, I can say nothing of them except that they are useful in exciting the mind to inquiry. A very brief consideration of the progress of experimental philosophy will show you that it is a great disturber of preconceived theories. I have thought long and closely on the theories of attraction and of particles and atoms of matter, and the more I think, in association with experiments, the less distinct does my idea of an atom or a particle of matter become."

In whatever epoch, continued the lecturer, we shall seek for models of human existence, we can find no two examples more conspicuous for their intellectual worth, more admirable for their lofty views of duty, than Michael Faraday and Justus von Liebig.

## NOTES

THE *Enterprise*, with the eclipse party for Camorta (Nicobar Islands), left Galle on the 18th inst. The *Baroda* with the Siam party should arrive at Singapore to-day, and a telegram has been received at the Admiralty that the Colonial steamer will replace the *Charybdis* in the journey to Bangkok, as the former is faster and possesses more accommodation. Letters have been received from the expedition at Aden. Drs. Vogel and Schuster have been engaged on board in photographically determining the chemical intensity of different parts of the solar spectrum at different times of the day, and most important results have already been secured.

HER Majesty the Queen has been graciously pleased to confer upon Mr. Henry Cole, C.B., the distinction of a Commandership of the Bath, in recognition of his eminent public services. The Executive Committee of the Cole Testimonial Fund have authorised the preparation of a decorative memorial tablet, with portrait of Mr. Cole in mosaic, as well as a marble bust. It is intended to offer these to public institutions, and the balance of the amount subscribed will be placed at the disposal of Mr. Cole.

THE Royal Irish Academy has given its sanction to the following grants from the fund placed at its disposal for aiding scientific researches by providing suitable instruments and materials:—25*l.* to Mr. Edward T. Hardman, for "Chemico-Geological Researches;" 30*l.* to Mr. W. H. Mackintosh, for "Researches as to the Structure of the Echinoidea;" 25*l.* to Mr. G. Porte, for "Micro-Photographic Experiments;" 40*l.* to Dr. Leith Adams, for "Explorations in the Caves of Shandon;"

25*l.* to Dr. Hansdel Griffiths, for "Experiments on the Effects of Certain Drugs on the Circulation;" 25*l.* to Dr. Reuben Harvey, for "Researches on Staining Reagents used in Histology;" and 30*l.* to Prof. A. H. Church, Cirencester, for report on the analysis of some rare mineral arseniates and phosphates.

At the meeting of the Academy held on the 16th March, the following were elected honorary members in the department of Science:—Joseph Bertrand, Paris; Bernard von Cotta, Freiburg; and Asa Gray, Cambridge, U.S.

THE following parts of vol. xxv. of the Transactions of the Royal Irish Academy have just been published:—Part 10, Researches in Chemical Optics, by the Rev. J. H. Jellott, B.D. Part 11, Report on the Strength of single-riveted Lap Joints, by Bindon B. Stoney, A.M.; with plate and tables. And the following are in the press:—Parts 12 and 13, On the First Comet in 1845; and On the Binary Star  $\mu^2$  Bootis, by Dr. Doberck. Part 14, On the Anatomy of Insectivorous Edentates, by A. Macalister, M.B.; with two plates. Part 15, On the Fern Flora of the Seychelles, by J. G. Baker, F.L.S.; with Notes on some of the Species, by E. P. Wright, M.D.; with four plates. Part 16, On the Structure of the Spines of the Diadematidae, by H. W. Mackintosh, A.B.; with three plates.

Two prizes of 30*l.* and 20*l.* each, the gift of Mr. J. T. Mackenzie, of Kintail, are offered by Aberdeen University for the best and second-best essays on "The Conservation of Energy, considered especially with reference to the Mechanical Theory of Heat." The essays must be sent in on or before the 1st of November next.

THE Vice-Chancellor of Cambridge University has announced that the election of a Jacksonian Professor of Natural Experimental Philosophy will be held in the Senate House on Tuesday, the 13th of April. The Rev. J. Clough Williams Ellis, M.A., Fellow of Sidney, who acted as Deputy Jacksonian Professor for two years, and Mr. James Stuart, M.A., Fellow of Trinity, are candidates for the vacant appointment.

DR. VON MICLUCHO MACLAY, the Russian traveller, has recently returned to Singapore from a journey into the interior of Tabore. The object of his expedition was to gather information about wild and almost unknown races inhabiting the Tabore jungles. These tribes are named Jakuns, Oran Rajet, and Oran Utan. As these races always withdraw deeper into the interior, seeking shelter in the forest and mountains on the approach of strangers, Dr. Maclay had to extend his explorations into places never yet visited by Europeans, and rarely even by the Malays. His travels occupied fifty days, proceeding sometimes by boat, but performing the greater part of the journey on foot. Dr. Maclay has, it is stated, succeeded in obtaining much valuable information regarding the habits and dispositions of these unknown tribes.

THE Agassiz Memorial Fund of 300,000 dollars is said to be nearly raised. The "teachers' and pupils' fund" alone exceeds 9,000 dollars.

AN International Horticultural Exhibition is to be held at Cologne from the 25th August till 26th September. All communications must be addressed, post paid, to the Horticultural Society "Flora," Cologne, from whence all necessary information can be obtained.

THE Council of the Royal Dublin Society advertise for candidates to fill the post of Keeper of the Minerals in their museum. The salary is 100*l.* a year, paid by a Government grant, and the keeper acts the part to a certain extent of assistant to Dr. Carte, the director. The gentleman appointed Keeper of the Minerals will also be elected Analyst to the Society and have charge of

their Chemical Laboratory, at an additional salary of 50*l.* per annum, with fees for analysis, the scale of fees chargeable to members of the Society being regulated from time to time by the Council. The interests of the mineralogical collection of the Society would appear to be perhaps unavoidably overlooked by the above arrangements, as the person elected must look for a livelihood to the fees for analysis.

LETTERS from Nordenskjöld, the celebrated Swedish polar explorer, intimate that he will very shortly leave Tromsøe for Novaja Semlja. He will spend only a few months on that island, and try a land journey from the mouth of the Lena or Obi throughout Northern Russia, travelling southwards, if possible, by boat. The funds are supplied by Mr. Oscar Dickson, the well-known Gottenburg merchant.

A SHOCK of earthquake was felt on the night of March 17 at several places in the province of Ravenna.

A NUMBER of large meteors were observed in several parts of France on the 9th and 10th of March. The meteor of Feb. 10 was seen in an immense number of localities, and additional notices are daily arriving at the Observatory.

M. DUMAS, Perpetual Secretary of the Academy of Sciences, is a candidate for the French Academy as well as M. Jules Simon, the ex-Minister for Public Instruction, who is an influential member of the department of Moral and Political Sciences. According to the rules enacted when the Institute was created, no member of one class could become a member of another. The rule was abolished when the academical constitution was remodelled by Napoleon I., but many academicians adhered to it. Arago refused several times to become a candidate in the French Academy.

AN edition of Laplace's works was published by the French Government about thirty years ago, and is now almost out of print. A new edition is preparing; it will be edited by the Academy under the superintendence of M. Dumas, assisted by a member of the Section of Geometry. A copy of the work will be presented by the Institute, at the anniversary meeting, to the pupil of the Polytechnic School who has obtained the first place.

M. WALLON, the new Minister of Public Instruction, has declined to appoint as his general secretary a member of the Versailles Assembly who desired the appointment, and has nominated M. Jourdain, a general inspector of the University and a member of the Institute. He has appointed as his *chef du cabinet*, not as is usually the case, a private friend or a member of his family, but M. Delfour, who is one of the ablest teachers in the Paris College. He has appointed M. G. Pouchet, the son of the celebrated advocate of spontaneous generation, to fill the room of M. Paul Bert, Professor of Physiology to the Sorbonne, as the latter, being a member of the National Assembly, cannot attend to his professional duties.

DR. FORBES WATSON, director of the India Museum, has published in a separate form the paper he read at the Oriental Congress in September last, and of which, at the time, we gave a report. It is entitled, "On the establishment in connection with the Indian Museum and Library of an Indian Institute for Lecture, Inquiry, and Teaching; its influence on the promotion of Oriental studies in England, on the progress of the higher education among the natives of India, and on the training of candidates for the Civil Service of India." The unsatisfactory state of the museum and library in the attics of the India Office is notorious. The collections in the museum are to be housed for three years in the eastern galleries of the International Exhibition building. But this is only temporary; and in the



interests both of science and of the commercial and political welfare of India, a special permanent building for the purposes so ably advocated by Dr. Watson is urgently required. We hope the recent memorials of the Chambers of Commerce of the United Kingdom, added to the long-continued exertions of the Asiatic and other learned societies, will have some success with her Majesty's Government. The site proposed by Dr. Watson for an Indian Institute is close by the India Office. Allen and Co. are the publishers of Dr. Watson's paper.

A BILL to reform the Gregorian year has been recently introduced into the American House of Representatives. Its essential provisions are that the beginning of the year shall correspond to the winter solstice, and its principal divisions to the summer solstice and the equinoxes, the latter provision being intended to take the place of the intercalary rule of the Gregorian calendar, thus regulating the divisions by the astronomical conditions of the earth's orbit.

The report of Capt. Elton on the Zanzibar copal trees (*Trochilobium Hornemannianum*) has become so well known, owing to its republication in many English journals, that it will be interesting to the botanical readers of NATURE to know that seeds taken from fruits collected by Capt. Elton and sent to the museum at Kew, through the Foreign Office, have not only germinated, but are growing into strong healthy plants; some of them are six or more inches high, and have six or seven pairs of leaflets. They are interesting, not only on account of the valuable fossil resin yielded by the old trees, but also on account of their being the first plants grown in Europe. Though there is always a steady demand for good copal in England, there can be no doubt that large quantities are still to be found beneath the African soil. In Loanda, on the opposite side of the African continent, large deposits of copal are known to exist, but owing to a superstition among the natives the resin is not allowed to be touched.

THE discovery of new medicinal products appears to be on the increase just now. Within the space of a few months we have heard of the extraordinary tonic effects of Boldo (*Boldoa fragrans*), which, however, seems destined to pass into oblivion. This was succeeded by Jaborandi, which is still occupying the attention of the medical profession, and which, unlike Boldo, is being reported upon very favourably. Two bales of another new product, under the name of Carnauba Root, are reported to have recently arrived at Liverpool. It is the root of the Brazilian Wax Palm (*Copernicia cerifera*), and is described as an excellent medicine for purifying the blood; equal, indeed, to sarsaparilla. It is a question, however, whether the latter has any real medicinal properties. The Carnauba Root as imported is said to be in pieces several feet in length, of an average thickness of three-eighths of an inch, of a mixed greyish and reddish brown colour, giving off here and there small rootlets. The cost is said to be not more than half that of sarsaparilla.

ONE of the chief products of Auckland, New Zealand, is Kauri gum, the semi-fossil resin of *Dammar australis*. It is especially a product of this province of New Zealand, being found in no other part of the world. The resin is found at a depth of from two to three feet from the surface over a large area of land once covered by Kauri forests, but now barren and almost unfit for cultivation. In these waste lands there is no restriction enforced by Government as to the right of digging for the resin, and it is calculated that in various parts of Auckland as many as 2,000 men have found employment at one time digging up the Kauri resin. This number, however, is now considerably reduced, owing to the demand for labour in other directions; nevertheless, large quantities of the resin are required by varnish-makers in this country, and consequently many persons still find employment in digging it. The Maoris bring a considerable quantity to market. The best quality fetches in the market at

Auckland from 30*l.* to 33*l.* per ton. At this price the gum-diggers are able to earn from 1*l.* 10*s.* to 4*l.* per week; the average earnings, however, are about 2*l.* per week. In the three years from 1870 to 1872, there were exported from Auckland 14,276 tons of Kauri resin, valued at 497,199*l.*

UNDER the title of "Note sur les Tremblements de Terre en 1871, avec Suppléments pour les Années antérieure de 1843 à 1870," M. Alexis Perrey, of the Belgian Academy, publishes a continuous list of earthquakes and of volcanic eruptions which have occurred from 1843 to 1871, one-half of the volume being occupied with those of the latter year. M. Perrey's object is simply to present as complete a list as possible of these phenomena, and he is therefore anxious to receive information of any omissions, so that future editions may be made still more complete. The list will no doubt be found of great use to those who are investigating seismic phenomena. It is published by Hayez, of Brussels.

A NEW phase in the archaeology of the United States is shown by the researches of Mr. Putnam in the caves of Kentucky, as he has found that many of the caverns there were used for burial, as in Europe, and that others were used for habitations. Many relics and skeletons have been brought to light by his investigations; and further research, which will be carried on this year in connection with the Geological Survey of the State, will undoubtedly add much of importance to the archaeology of that country. Enough evidence has already been obtained to prove that the caves were very extensively used by an early race of men, but the race to which the remains should be referred is not yet determined. In his investigations in the vicinity of a group of mounds in Monroe County, Kentucky, Mr. Putnam was also quite fortunate in finding a peculiar mode of burial that has not before been noticed, inasmuch as the bodies, in one grave ten in number, were buried in a circular grave, made by placing erect slabs of limestone around a floor laid with thin stones. The bodies had all been placed in the grave at the same time, and evidently in a sitting posture, with their backs against the slabs. The skulls show a race remarkable for the shortness of their heads, and in one case at least exhibited a posterior flattening. The bones of the skeletons were quite thick and massive, and the shin-bones were remarkably flat.

WE have to record the recent publication of another portion of the important work upon the economical and natural history of the insects of the United States, undertaken by Prof. T. Glover, of the Agricultural Department at Washington, and upon which he has been engaged for many years. Many years ago Prof. Glover commenced illustrating the entomology of the country by engraving figures of the various species of insects directly upon copper plates, and he has now several hundred such plates completed, containing illustrations of thousands of species, among them nearly all of the various orders that are in any way interesting or important, either from their general prominence or from their relations to man, as being destructive or beneficial. For the purpose of putting his labours before the public he has commenced issuing monographs of particular orders and families, and has already published one volume on the Orthoptera. He has recently sent forth a second volume, entitled "Manuscript Notes from my Journal of Illustrations of Insects, Native and Foreign; Diptera, or Two-winged Flies." The one thing to be regretted is the smallness of the edition of this valuable work by Prof. Glover, only forty-five copies having been issued.

SOME recent numbers of the *Montreal Gazette* contain a detailed account of the progress of scientific research in Canada during 1874. From this we learn that Mr. James Richardson (of the Geological Survey) spent the months of May, June, and July in a topographical and geological examination of the inlets on the coast of British Columbia, between the 52nd and 55th degrees of north latitude. Mr. George M. Dawson, geologist and botanist

to the Boundary Commission, has been engaged in continuing the examination of the region in the vicinity of the 49th parallel. Prof. Bell has been again engaged during the past summer in the North-west Territories. Mr. Henry G. Vennor spent the greater part of the summer in extending his researches through the rear portion of Lanark County, Ont., and towards the end of the season had succeeded in working out the geological structure of the whole of it. Further details are given concerning laboratory and other work done during the year by various scientific workers, all showing considerable activity in science on the part of the Canadians.

The following are the probable arrangements for the Friday Evening Lectures at the Royal Institution after Easter:—April 9, Sir William Thomson, LL.D., F.R.S.: "Tides." April 16, Prof. Gladstone, F.R.S., M.R.I.: "Progress of Science in Elementary Schools." April 23, Prof. Ramsay, LL.D., F.R.S.: "The Pre-Miocene Alps, and their subsequent Waste and Degradation." April 30, Walter Noel Hartley: "Action of Heat on Coloured Liquid." May 7, M. Cornu (École Polytechnique): "Velocity of Light." May 14, John Evans, F.R.S.: "Coinage of the Ancient Britons and Natural Selection." May 21, J. Baillie Hamilton: "Application of Wind to Stringed Instruments." May 28, Col. Lane Fox, M.R.I.: "Evolution of Culture."

THE additions to the Zoological Society's Gardens during the past week include a Lesser Sulphur-crested Cockatoo (*Cacatua sulphurea*) from Moluccas, presented by Mr. H. W. Wood; an Annulated Snake (*Leptodira annulata*) from Jamaica, presented by Mr. H. B. Whitmarsh; a Diana Monkey (*Cercopithecus diana*) from West Africa; a Common Rhea (*Rhea americana*), three Snowy Egrets (*Ardea candidissima*), a Common Boa (*Boa constrictor*) from South America, purchased.

#### SCIENTIFIC REPORT OF THE AUSTRO-HUNGARIAN NORTH POLAR EXPEDITION OF 1872-74\*

##### III.

DURING winter the air seemed always to contain particles of ice; this was seen not only by parhelia and parselenæ when the sky was clear, but also in astronomical observations. The images of celestial objects were hardly ever as clear and well defined as they are at home, although the actual moisture in the atmosphere was far less. It happened very often that with a perfectly clear sky needles of ice were deposited in great quantities upon all objects. It was quite impossible to determine the quantity of atmospheric deposits, as during the snowstorms no distinction could be made between the snow actually falling and that raised from the ground by the storm; it was remarkable, however, that during the first winter the quantity of snow was small compared with that of the second winter, when the snow almost completely buried the ship (this happened near Franz-Joseph's Land). The same proportion was repeated in the quantity of rain during the first and second summer; in the first only a little rain fell late in the year, while in July 1874 it rained in torrents for days.

Clouds are naturally of a very different character from those seen at home; nimbus and cumulus are never seen. The form of cloud is either that uniform melancholy grey of an elevated fog, or cirrus; the latter consists of round but undefined masses of fog at but a small elevation, therefore somewhat different from the cirrus of the temperate zone. Instead of clouds, fogs are prevalent, now higher, now lower, and twenty-four hours of clear weather rarely occur during the summer; generally the sun is seen for a few hours, then to disappear again behind the thick fogs. Melancholy and depressing as the effect of these eternal fogs may be, they are nevertheless necessary for the general conditions of the ice; they form the binding media for the heat of the sun's rays, and melt more ice than the direct rays.

Parhelia and parselenæ were often observed; they always were certain indications of snowstorms that followed them. A new

\* Die 2. Oesterr.-Ungarische Nord Polar Expedition, unter Weyprecht und Payer, 1872-74. (Petermann's Geogr. Mittheilungen, 1875; heft ii.) (Continued from p. 398.)

phenomenon was only observed once, when, besides the double system of parhelia, two other mock suns appeared on the same altitude with the real sun.

On the whole path which the vessel described soundings were made constantly, and the depth of the sea was found to increase towards the east; on the easternmost point, 73° E. long., there were 400 metres of water, and the depth steadily decreased towards the west. In front of Franz-Joseph's Land there is a bank which seems to reach as far as Nowaja Semlja; beyond it the depth increases again. The whole area east of Spitzbergen rarely exceeds 300 metres in depth. Lieut. Hopfgarten specially constructed an instrument to fetch up dredgings, which was frequently done. The deep-sea temperatures were measured with Casella's minimum and maximum thermometer, and these measurements were continued throughout the winter. They showed a slight increase in the temperature at the bottom. The percentage of salt in the sea-water at different depths was also determined. Until the ship was blocked up the surface temperatures of the sea were also measured. Lieut. Weyprecht thinks that, as a rule, too much importance is attached to these, as the state of the weather is not taken into account, and it is just that which has the greatest influence upon the surface temperature; it is quite wrong to imagine the existence of currents from observations of this kind.

During their drift the explorers made good use of the dredging net; it was generally kept on the bottom during half a day, and thus areas of several miles' extent were examined. The collection obtained in this way no doubt completely represents the fauna on the bottom of the sea which the explorers visited. At places animal life was so plentiful that the net came to the surface completely filled. Crustacea were particularly plentiful; unfortunately the larger specimens remained in the ship, as they could not be transported. Dr. Kepes has handed the valuable collection to the Imperial Academy of Sciences (Vienna), and specialists are now busily engaged upon it. Other collections had to remain behind, but were not very valuable, as the explorers only touched land during winter, when everything was covered with snow; they certainly possessed a rather complete collection of birds, but these were all known species, with the sole exception of a *Lestrin*, which Dr. Kepes could not define. Of great value, however, were sixty-seven bearskins, which had already been prepared and well packed; there were some splendid skins amongst them, most of them winter skins, which are rarely obtained in trade and are much finer than the summer skins.

Higher animal life is rather limited in those regions; the principal representatives are the polar bear and the seal, the former in such numbers that the explorers could never leave the ship without weapons; he caused them many a disagreeable surprise, but was always a welcome guest, as he provided them with a fresh and strengthening repast. The seal, in two species, *Phoca barbata* and *Phoca groenlandica*, is everywhere where open water appears between the ice, although not in such quantities that seal-hunting would pay. The walrus was only seen once, not far from Franz-Joseph's Land, although the explorers often passed over good walrus-ground. Of whales they only saw one species in the vicinity of coasts, where it was very frequent.

Birds were very numerous near the land, but the further the ship drifted away the scarcer they became, and during the last part of the explorers' retreat in the ice the appearance of a bird was a rare phenomenon.

Interesting as all these observations doubtless may be, and in spite of the numerous and long tables they contain, they yet do not possess that high scientific value which might be reached under different circumstances. They only give us a picture of the extreme effects of natural forces in the Arctic districts, but on their causes, the why, we are just as much in the dark as before; and the reason of this lies in the fact that there are no simultaneous observations in another district for comparison. Only when we possess those shall we be enabled to make correct conclusions as to the causes, the origin, and the nature of the abnormal phenomena in the Arctic Zone. The keys to many enigmas in nature, which for centuries it has in vain been tried to solve—such as those in terrestrial magnetism, electricity, and the best part of meteorology, &c.—are doubtless hidden near the poles of the earth; but as long as polar expeditions are nothing more than an international race in honour of one or another flag, having as principal object only to get a few miles nearer to the pole than the last explorers, so long these enigmas will most decidedly remain unsolved.

Pure geographical research, *i.e.* Arctic topography, which until

now was foremost with all polar expeditions, must recede before the far more important scientific questions. But these questions cannot be answered before all nations that claim a place at the head of civilisation leave aside all national rivalry, and resolve to make progress together in this direction. To obtain decisive scientific results, a number of simultaneous expeditions are absolutely necessary, and their object must be to collect or construct tables of yearly observations at different points round the pole, but their instruments and method of observation should be exactly alike. Only when this is done will the materials be furnished for the solution of those great problems of nature which are now mysteriously enwrapped by Arctic ice; only then will we reap the benefit of that enormous capital of labour, efforts, sufferings, and money which until now have been wasted in the polar district.

With regard to the means to reach the highest latitude, the camp of explorers is divided into two; some are in favour of ships, others expect everything from sledges. As long as it is the principal object of an expedition to reach high latitudes, sledges are doubtless preferable, but when higher results are aimed at, only ships can give the necessary basis to work upon. It is a great illusion to imagine that both can be perfectly united; on the contrary, one will always have to be subservient to the other, and they will generally be hindrances to each other.

Finally, Lieut. Weyrecht tenders his thanks to the officers of the expedition, whose untiring efforts and energy, frequently under the most difficult and sometimes the most dangerous circumstances, alone made it possible to present the scientific world at home with the above data of observations and results.

### SCIENTIFIC SERIALS

THE *Journal of the Chemical Society* for February 1875 contains two original papers by Mr. A. H. Church. The first is on the composition of autunite. The recent discovery of a new locality in Cornwall for autunite induced Mr. Church to make a fresh examination of this mineral species. The quantity at his disposal was rather small, but as a remarkable peculiarity concerning the condition of the water in this mineral presented itself, the author availed himself of two fine French specimens. The Cornish specimens occurred in thin isolated rhombic tables, translucent to sub-transparent, and were sulphur-yellow. We then have a minute description of the analysis made, and in conclusion Mr. Church finds the formula of autunite, as it exists in the unaltered crystals, to be  $\frac{U_2O_3}{CaO} \left\{ P_2O_5 \cdot 10H_2O \right.$ , whereas autunite dried in vacuo is  $\frac{U_2O_3}{CaO} \left\{ P_2O_5 \cdot 2H_2O \right.$ . Upon examination of the closely allied uranium copper phosphate, *torbernite*, it did not show analogous results, and the author found the formula of *torbernite* to be  $\frac{U_2O_3}{CuO} \left\{ P_2O_5 \cdot 8H_2O \right.$  and  $\frac{U_2O_3}{CuO} \left\{ P_2O_5 \cdot 2H_2O \right.$  respectively; the latter, if the mineral is dried at 100°. Mr. Church considers, in conclusion, that there are cases in which the drying of minerals in vacuo removes essential water, and not accidental moisture only; and he further believes that absolutely dry air does, in still rarer instances, effect a similar alteration.—The second paper is on the action of baryta on oil of cloves. Considerable differences existing amongst chemists on the action of caustic baryta on eugenol, the author repeated experiments he had made some time ago on a larger scale, and with eugenol from oil of cloves of ascertained genuineness. The author first gives a description of experiments as to the physical characters of pure eugenol itself, and of the terpene with which it is associated in clove oil. We then come to the experiments with baryta, and their result was the conclusion that the action of baryta on eugenol is not a precise or definite one; that a greater part of the eugenol is carbonised and destroyed, and that from the products of such destruction a minute proportion of the remaining eugenol receives an addition of  $CH_2$ , becoming thereby converted partly into methyl-eugenol and partly into another body of the same empirical formula, and possibly isomeric with the ether. It is clear, therefore, that none of the former conclusions as to the nature of the action of baryta on eugenol are correct.—The remainder of the journal is dedicated to abstracts of papers published in other journals, many of which have already been noticed in these columns.

*American Journal of Science and Arts*, February.—The first paper in this number is Prof. Asa Gray's address on Jeffries

Wyman at the Memorial Meeting of the Boston Society of Natural History, Oct. 7, 1874, to which, as well as to the subject of it, we have already referred.—On some points in the geology of the Blue Ridge of Virginia, a paper by Mr. W. M. Fontaine, is concluded in this number.—Mr. J. D. Dana reviews Dr. Sterry Hunt's "Chemical and Geological Essays," and Prof. Asay Gray contributes a short paper on the question, "Do varieties wear out?" The conclusion which he reaches we gave in a recent number (vol. xi. p. 334). In "Communications from the laboratory of Williams College," Mr. Ira Remsen treats of (1) the formation of paratoluic acid from parasulphotoluic acid; (2) nitro-parasulphobenzoic acid; and (3) the action of potassium on ethyl succinate.—Another chemical paper is by Mr. M. Carey Lea on the detection of hydrocyanic acid.—M. A. E. Verrill sends his thirtieth contribution to zoology, from the museum of Yale College; it treats of the gigantic cephalopods of the North Atlantic, and is illustrated with some good cuts.—Among the smaller notes is a useful summary of the results obtained at twenty-six transit stations, twenty in the northern and six in the southern hemisphere.

*Transactions of the Geological Society of Manchester*, vol. xiii., part 7.—The papers in this part are—the President's (Prof. W. Boyd Dawkins) address on the most important additions during 1873-74 to our knowledge in those departments of geology that relate to mining, engineering, and terrestrial physics; "Fish Remains from the Coal Measures," by Mr. John Aitken, F.G.S.; "Geology of the Parish of Halifax," by Mr. James Spencer.

*Memorie della Societa degli Spettroscopisti Italiani*, Dec. 1874.—Father Secchi writes on the physical study of the comets Coggia and Tempel 1874. He appears to have spectroscopically examined these comets on every opportunity, and to have compared their spectra with a Geissler's tube in front of the object-glass. He found the spectra of a hydrocarbon gas did not correspond with that of the comet; the brightest band of the spectrum of  $HC_2$  is in the blue, while that of the gas CO or  $CO_2$  is in the green, just as in Coggia's comet. On the other hand, the blue band is the brightest in the spectrum of Tempel's comet; and Secchi therefore attributes its light to a hydrocarbon. The nucleus appears to have given off polarised light, and also the surrounding portions of the comet. On July 9 the continuous spectrum of the nucleus appeared broken for a short distance on the red side of each of the hydrocarbon bands. On Sept. 5 Borrelly's comet appeared to have a number of bright points of nuclei dispersed throughout the comet.

*Astronomische Nachrichten*, No. 2,021.—Julius Schmidt communicates the observations on the number of sun-spots seen every available day at Athens. The average number of groups in January seems to be about five; in April it had decreased to two, and this average remained nearly constant throughout the remainder of the year. Position observations of Coggia's comet, by J. Dreyer, of Birr Castle, and the discovery of Planet 141, by Paul Henry, appear in this number. The transit of Venus appears to have been seen well at Java, by Metzger; the different appearances at various times during the transit are given. The eclipse of the sun was observed at Leipzig in January. It appears from the observations of the ends of the eclipse that the last contact was seen with the larger apertures before it was so seen with the smaller one.

*Zeitschrift der Oesterreichischen Gesellschaft für Meteorologie*, Jan. 15.—The first paper is a contribution by Dr. Hildebrandson to the question of the condition of vapour in the atmosphere, founded on researches made by him and Prof. Rosen some years ago, and not before published, to his knowledge, beyond Sweden, Le Roy started, and Saussure accepted the theory, that air dissolves water or vapour as a fluid dissolves a salt. Wallerius, de Luc, and Dalton, on the other hand, were of opinion that vapour is formed through the action of heat exactly in the same way in a vacuum as in air. Since the demonstrations of Regnault, the latter view has been generally adopted. By experiments resembling those of Rudberg and Regnault, Dr. Hildebrandson and Prof. Rosen came to the following conclusions.—1. If a gas or vapour of water be brought (mechanically or by evaporation) into a volume of gas, this volume is immediately compressed or shoved aside until the difference in pressure is annulled. 2. If a gas or vapour of water be taken (mechanically or by condensation) from a volume of gas, this volume of gas rushes in from all sides to fill up the vacuum or equalise pressure. The condensation of vapour therefore doubtless plays a large part in the origin and propagation of storms,

not only by the liberation of heat, but also by the sudden diminution of pressure, which causes an inflow of air and vapour. 3. When different gases and vapours are at rest next each other, they mix and diffuse thoroughly till the mixture becomes homogeneous. Hence it follows: (1) That the permanent gases, of which air consists, are not independent atmospheres, but thoroughly penetrate each other. This result is confirmed by all experiments, which show the composition of the air at all attainable heights to be the same. (2) That the ceaseless evaporations and condensations render impossible the existence of an independent vapour atmosphere, or of a homogeneous mixture of vapour with the permanent gases, and cause a rapid decrease of vapour pressure with increase of height. (3) It is not permissible to subtract the tension of vapour from the height of the barometer, in order to find the pressure of dry air.—An article follows in the *Kleiner Mittheilungen* on the law of Dalton, respecting the independence of gas atmospheres, and on the composition of the air at great heights. The researches of Maxwell, Boltzmann, and especially of Stefan, lead to these results: The definitive equilibrium of a gas is determined by the law of Dalton, but not the manner in which the gas disposes itself before it has come to equilibrium. According to that law the mixture of two gases would take place with great rapidity, while experience shows the process to be very slow. The subtraction of vapour-tension from the height of the barometer is a false application of the law, and a reading thus corrected has a purely local signification in the narrowest sense.

The four numbers of the *Nuovo Giornale Botanico Italiano* for 1874 contain the results of a good deal of work done by Italian botanists, though several of the papers are by Russians, and are printed in French. A large proportion of the papers in this vol. vi. relate to Cryptogams; including one by Prof. Thetistiakoff on the development of the sporangia and spores in *Polypodium cœcæ*; by G. Arcangeli, on certain Fungi of the neighbourhood of Leghorn, and on Algae of the group *Cœloblastæ*; by N. Sarokin, on the development of *Horridium varium*, an Alga belonging to the family Ulothricaceæ; and by Prof. Thetistiakoff on the development of the spores of *Equisetum limosum* and *Lycopodium alpinum*, the subject being treated both in this and the previous paper by the same writer as a contribution to the history of the vegetable cell.—V. Cesati has a paper on hybridisation in the genus *Achillea*, and on the gemmiparous leaves of *Cardamine pratensis*. There is a useful bibliography in each number, and we have a report of the proceedings of the Botanical Congress held at Lucca in 1843.

## SOCIETIES AND ACADEMIES

### LONDON

Royal Society, March 18.—“Report on Observations of the Transit of Venus made at Luxor, Upper Egypt, 19th December, 1874.” By Vice-Admiral E. Ommanney, C.B., F.R.S.

“Preliminary Abstract of Approximate Mean Results with the Invariable Pendulums Nos. 4 and 1821, in continuation of the Abstract published in vol. xix. of the Proceedings.” By Captain W. J. Heaviside, R.E. Communicated by Professor Stokes, Sec. R.S.

Linnean Society, March 18.—Dr. C. J. Allmann, F.R.S., president, in the chair.—Mr. Rothery exhibited a convenient apparatus for drying plants when on a walking expedition.—The following papers were read:—On thirty-one new species of marine Planarians from the Eastern Seas, by Dr. Collingwood. On the resemblances of Ichthyosaurian bones with the bones of other animals, by Mr. H. G. Seeley.

Geological Society, March 10.—Mr. John Evans, V.P.R.S. president, in the chair.—The following communication was read:—“The Rocks of the Mining Districts of Cornwall, and their relation to Metalliferous Deposits,” by Mr. John Arthur Phillips, M.I.C.E. In this paper the author adduced numerous facts observed by him in the examination of the rocks of the mining districts of Cornwall which led him to the following conclusions:—The clay-slates of Cornwall differ materially in composition, but no rearrangement of their constituents could result in the production of granite. Some of the “greenstones” of the Geological Survey Map are volcanic rocks contemporaneous with the slates among which they are found, whilst others are hornblende slates, diorites, &c. Granites and elvans having a similar chemical and mineralogical composition were probably

derived from the same source; but the volume of the bubbles in the fluid-cavities of both having no constant relation to the amount of liquid present, do not afford any reliable data from which to calculate the temperatures at which these rocks were respectively formed. The stone-cavities of elvans, and probably of some other rocks, are often the results of the irregular contraction, before the solidification of the base, of imbedded crystals of quartz. In rocks having a glassy base, glass-cavities will be produced. The vein-fissures of the tin- and copper-bearing lodes of Cornwall were produced by forces acting after the solidification of the elvans, but in the same general direction as those which caused the eruption of the latter; and these fissures were afterwards filled with minerals deposited by chemical action from water and aqueous vapours circulating through them, but not necessarily at a high temperature. How far these deposits were produced by water rising from below or influenced by lateral percolation cannot be determined; but the effects produced on the contents of veins by the nature of the enclosing rock, and the occurrence of deposits of ore parallel with the line of dip of the adjoining country, lead to the conclusion that lateral infiltrations must have materially influenced the results. Contact-deposits and “stockwerks” have been formed by analogous chemical action, set up in fissures resulting from the junction of dissimilar rocks, or in fractures produced during the upheaval of partially consolidated eruptive masses. The alteration produced in stratified deposits in the vicinity of eruptive rocks is probably often due to similar percolations. It is not improbable that quartz may sometimes retain a certain amount of plasticity after it has assumed a crystalline form.

Zoological Society, March 16.—Dr. A. Günther, F.R.S., V.P., in the chair.—Mr. Howard Saunders exhibited a specimen of a Gull obtained by Mr. Gervaise Mathew, R.N., at Magdalena Bay, Lower California, closely resembling *Larus fuscus*, a species hitherto unrecorded from the New World.—A letter was read, addressed to the Secretary by Capt. John Biddulph, containing remarks on the Wild Sheep met with during his recent journey to Yarkand.—A letter was read from the Rev. J. S. Whitmore, of Samoa, South Pacific, giving particulars as to the occurrence of the Palolo (*Palolo viridis*) on the shores of that island in 1874.—Prof. W. H. Flower, F.R.S., read a memoir on the anatomy and affinities of the Musk Deer, (*Moschus moschiferus*). After an exhaustive account of the structure of this animal, based on the examination of a specimen that had recently died in the Society's Gardens, Prof. Flower came to the conclusion that it was most nearly related to the *Cervidae*, and might be placed within the limits of that family.—A communication was read from the Rev. O. Pickard-Cambridge, in which he gave the description of twenty-four new species of spiders of the genus *Erigone*, from France, Corsica, Sicily, Spain, Morocco, and Algiers.—Dr. A. Günther, F.R.S., read a second report on the collections of Indian Reptiles recently obtained by the British Museum, and described several species as new to science.—A paper was read by Messrs. Sclater and Salvin, containing an account of the birds collected by Mr. A. Goering on the Sierra Nevada of Merida, and at San Cristoval in Venezuela in 1874.—A communication was read from M. L. Taczanowski, containing the description of a new species of grouse from the mountains of Georgia, allied to the Black Grouse, which was proposed to be called *Lyrurus moscovitici*.—Mr. A. G. Butler read the descriptions of a large number of new species of *Sphingida*.—Sir Victor Brooke gave a notice of a Deer allied to the Fallo Deer from Mesopotamia, of which he had lately received specimens from Mr. P. J. Robertson, H.B.M. Vice-Consul at Bussorah. For this new form, which is found in the jungles along the valley of the Euphrates, Sir V. Brooke proposed the name *Cervus mesopotamicus*.

Meteorological Society, March 17.—Dr. R. J. Mann, president, in the chair.—The following communications were read:—On the climate of Patras, Greece, during 1873, by Rev. Herbert A. Boys. This year was remarkable for sudden fluctuations and great ranges of temperature; the rainfall, amounting to 26.15 inches, was about the average, but the number of wet days (for that place) was great. The summer months, however, were very dry, there being only five days in June, none in July, and one in August, on which rain fell. There was a period of sixty-eight days from June 24 to August 30, without any rain whatever.—On ozone, by Mr. Francis E. Twemlow. This paper gives an account of nearly all that is known of this remarkable substance. An interesting discussion followed the reading of the paper, bearing chiefly upon the amount of oxygen in the

air at various health-resorts.—On the annual means of thirteen years' observations at London, by Mr. Richard Strachan. The author, having already read a series of papers on the different seasons, now gives a summary of the results for the thirteen years. The mean annual value for pressure from observations made at 9 A.M. is 29.958 inches; the mean temperature of the air at the same hour, 49° 6'; the annual amount of rain, 24.2 inches; the number of rainy days, 165; the resultant direction of the wind, S. 84° W., and its force 0.95. The author concludes as follows:—On the whole it seems that excess of pressure accompanies deficiency of rainfall, rapid translation of the air from the north of west, and fair weather. Deficiency of pressure accompanies excess of rainfall, rapid translation of air from the south of west, and foul weather. If meteorological science could give presence of the annual value of any one of the elements, the others could be predicted with considerable accuracy.

**Geologists' Association, March 5.**—W. Carruthers, F.R.S., president, in the chair.—On the relative age of some valleys in the north and south of England, and of the various Glacial and Post-glacial deposits occurring in them, by C. E. De Rance, F.G.S. The application of geology to agriculture and medical science caused the want of an exact knowledge of the various superficial deposits, which lie scattered over the country, to be felt, and led the late Sir Koderick Murchison to direct the Government Geological Survey in future to prepare a drift edition of each map, showing the actual deposit at the surface. The publication of such maps of the lower Thames valley and of South Lancashire enabled the author to compare the sequence of deposits in these two important districts, and the results arrived at, with the sequence exhibited in other areas. In Lancashire the Glacial Drift deposits attain a thickness of 200, and in one instance of 400 feet, and the valleys of the Ribble, Irwell, and Mersey were shown to have been excavated in these deposits by the denuding action of these rivers in Post-glacial times, which, as they gradually cut their valleys lower and lower, left wide and extensive terraces of river gravels on the slopes above; Manchester, and the villages between it and Altrincham, being built on one of these terraces. Of still newer date is the alluvial plain beneath the terraces, which is made of loam, peat, and river gravel. The peat was shown to be connected with the great peat mosses of West Lancashire, where it reaches 30 feet in thickness, and was correlated with the peat beds and submerged forests found beneath the sea-level, around the entire coasts of the British Isles and the North of France. Beneath the peat in the West Lancashire plains occurred the Pressall marine gravel, which was correlated with the Burth beds of Somersetshire, the raised beaches of Sussex, of the Isles of Wight and Portland, and of Cornwall; also with the fluviatile gravel lying beneath the peat horizon, in the Lancashire valley alluvial plains, and in the tin-bearing gravels of Cornwall. The subsidence marked by the marine beds, and subsequent elevation, during the forest continental era, followed by a subsidence to existing levels, took place after the rivers had cut down their valleys to their present depth, with few exceptions, Neolithic man entering the country during the forest era. The far older terraces on the valley slopes were compared with the implement-bearing gravels of the Post-glacial valley of the Ouse at Bedford, and with similar ancient high-level gravels in the Thames, the Hampshire Basin, the Somme, and the Seine near Paris, where no Glacial deposits occur, and it was argued, that regarding the similar relation to the depth of the valleys excavated, to the drainage area, and the position of the implement-bearing high-level gravels—that these, like the terraces of gravels of Lancashire without implements, and those of Bedfordshire with, were alike of Post-glacial date. In the Pre-glacial continental era the Thames flowed in a similar direction to the existing river, but 100 feet above its present level, its course nearly defining the southern limit of the subsequent Glacial sea, under which the Weald of Kent and Sussex was never submerged. In Post-glacial times the Thames may have denuded the southern edge of the Glacial deposits, when it commenced to cut down its present valley and to deposit its oldest and higher river gravels, which are immediately overhung by the Glacial beds. The valley appears to have attained its greatest depth in the era immediately preceding the subsidence that occurred prior to the great peat and forest period, the bottom of the valley east of London being considerably lower than the bed of the present stream, but the level is not sufficiently low to lead to the belief that any streams that may have flowed from the watershed of the Weald antinical, through what is now the

Straits of Dover, to the prolongation of the Thames, would have cut sufficiently deep to have produced fissures that might have been fatal to either of the proposed lines of the Channel Tunnel.

**Royal Horticultural Society, March 9.**—Adjourned Annual Meeting.—Viscount Bury in the chair.—The Chairman moved the adoption of the amended report of the Council. The proposal of Messrs. Prince to construct a skating-rink, and to pay a rent equal to 1,100*l.* a year, had fallen through owing to H.M. Commissioners (without whose consent the Society had no power to underlet any portion of its premises) having deemed it inexpedient to grant their consent. The report also pointed out that "the ordinary income of the Society cannot support its present expenditure," and that "unless the rent of 2,400*l.* is paid to H.M. Commissioners next year the lease of the South Kensington Gardens may be forfeited, and to prevent this contingency an increased revenue must be obtained."—The Chairman announced that since the adjourned meeting, two members of Council, Sir A. Slade, Bart., and Mr. Chetwynd, had resigned, and the legal advisers of the Society had advised them that these vacancies must be filled by the Council, and not by the Fellows. In the interval, also, a despatch had been received from H.M. Commissioners, stating that they regarded the legal status of the Council as now free from objection, and were ready to resume official relations with it.—After some discussion, the amended report was unanimously adopted, and the Council having promised to summon a general meeting to consider the present position of the Society, the meeting adjourned.

**Victoria (Philosophical) Institute, March 15.**—C. Brooke, F.R.S., in the chair.—Rev. J. McCann, D.D., read a paper on the nature and character of evidence for scientific purposes. He commenced by stating that the mind could alone gain scientific knowledge by the process of generalisation. This must be based on evidence that was sufficient, and such as warranted the inferences drawn from it. The nature of evidence was then examined, and the difficulty, but necessity, of correct observation and logical reasoning from this, in order to form a sound hypothesis, was shown. Various points in Prof. Tyndall's address were criticised.

#### GLASGOW

**Geological Society, March 11.**—Mr. John Young, F.G.S., vice-president, in the chair.—The following papers were read:—Notes on a tract of vertical trees in carboniferous strata; and on river debris found in sandstone, by Wm. Grossart, Salzburg. In his first paper, the author described a number of trees which had been found in a pit, 40 fathoms in depth, lately sunk to the "Little Drumgray" coal in the west end of Shotts parish. This coal is of an average thickness of 22 inches, and is overlaid by a compact sandstone of from two to five fathoms in thickness, with a few inches of grey shale, seldom exceeding a foot, separating the coal from the sandstone above. In the workings of the mine eight erect tree-trunks had been brought to light, all resting on the coal-bed, and disappearing in the shale forming the roof of the mine; but there had been no opportunity of observing if they entered the sandstone above. The usual organic markings found on similar remains were absent, so that it was impossible to determine precisely to what genus they belonged. In his second paper, Dr. Grossart described a series of beds overlying the "Virtue Well" coal in his neighbourhood, the uppermost being a sandstone, 60 feet in thickness. Below this is a gritstone bed, two feet in thickness, containing rounded and angular pieces of quartz embedded in sand, also remains of trees, pieces of black shale, and gas coal. This is succeeded by a thin shale bed, then by a laminated sandstone ten feet in thickness, followed by a black shale resting on the coal. From a review of the whole series, the author concluded that the beds under consideration were formed at the mouth of a river flowing from east to west at a period posterior to the formation of the Virtue Well coal.

#### MANCHESTER

**Literary and Philosophical Society, Jan. 18.**—Mr. John Barrow in the chair.—Mr. James Cosmo Melville, F.L.S., read a paper on the botany of Wilmington, North Carolina, with an especial reference to the habitat of *Dionaea muscipula*, Ellis.

Feb. 15.—Mr. Charles Bailey in the chair.—Mr. Rogers exhibited a specimen of *Carex ornithopoda*, Willd., collected by Mr. J. Whitehead in Millersdale, Derbyshire, in July of last year.—Mr. Sidebotham, F.R.A.S., then read a paper, entitled, "Notes on the Botany and Natural History of Tenby and the

"Neighbourhood."—Mr. Spencer Bickham read a paper on the different kinds of beehive used in this country, and exhibited specimens.

Feb. 23.—Mr. R. Angus Smith, F.R.S., vice-president, in the chair.—Mr. Joseph Sidebotham, F.R.A.S., sent for exhibition a specimen of the Colorado Potato Beetle (*Doryphora decolmeata*), which had appeared in great numbers in Canada last year, and had caused great destruction in the potato crops.—E. W. Binney, F.R.S., V.F., exhibited to the Society specimens of a strong arenaceous shale, approaching to a flagstone, containing numbers of macrospores of *Lepidodendron*.

March 9.—Edward Schunk, F.R.S., president, in the chair.—On Mr. Millar's method of finding the axes of an ellipse when two conjugate diameters are given, by Mr. Robert Rawson.—Mr. A. M'Dougall invited attention to a specimen of carbon formed upon the roof of a gas retort, by the decomposition of the hydrocarbon gas by heat. The carbon thus formed resembles graphite in its almost metallic lustre, and it was suggested that its mode of formation might throw some light upon that of graphite.—On the presence of sulphate of copper in water heated in tinned copper boilers, by William Thomson, F.C.S.—Prof. W. Boyd Dawkins, F.R.S., exhibited a collection of articles of the Neolithic and Bronze ages from the pile dwellings in the Lake of Bienné, lately presented to the Manchester Museum; Owens College, by Mr. J. Thompson. He called attention to the fact that the Neolithic peoples were the first herdsmen and farmers of whom we have any trace, and stated that to them we owe the introduction into Europe of domestic animals and of cultivated cereals. They were also the first weavers and gardeners. From the southern character of some of the domestic animals such as *Sus palustris*, and of some of the vegetables such as the Egyptian wheat and *Silene cretica*, it may be inferred that they came from the south, probably from the south-east, from the warmer regions of Central Asia.

## WATFORD

Natural History Society, March 11.—Mr. John Evans, F.R.S., president, in the chair.—On the Cretaceous Rocks of England, by Mr. J. Logan Lobley, F.G.S. As an introduction to the study of the geology of Hertfordshire, the author described the stratigraphical relations and the geographical extension of the entire Cretaceous system and of its various subdivisions. The composition and origin of the chalk, including the results of the recent researches of the *Challenger* expedition, was specially dwelt upon, and the hypothesis of the organic origin of clays as well as of limestones was discussed. The relation of geology to botany was pointed out, and the members of this new Society were urged to make themselves acquainted with their local geology as a prelude to a more extensive knowledge of geological science.

## PHILADELPHIA

Academy of Natural Sciences, Sept. 8.—Dr. Ruschenberger, president, in the chair.—"Notes on Santa Fé Marls and some of the contained Vertebrate Fossils," by Mr. E. D. Cope.—On a new variety of *Helix*, by James Lewis, M.D.—Prof. Leidy stated that in the early part of last June, in examining some of the material obtained from a mill-pond at Absecon, New Jersey, he had observed a most wonderful amoeboid animal, of which he had made notes, but was not able at the time to make a drawing and satisfactory description. Subsequently he sought patiently for two days in the same material for another individual, but without success. Last week he paid a visit to the Absecon mill-pond to seek the curious amoeboid, and was so fortunate as to find it again. Prof. Leidy exhibited a drawing of the animal, and described it as follows:—"The animal at rest is spherical or oval, or constricted back of the middle. In the spherical form it measured the one-fifth of a millimetre in diameter; in the oval and constricted form it was about one-fourth of a millimetre long, and one-sixth of a millimetre broad. It is white or cream-coloured, opaque, or translucent at the border, and was spotted green from food-balls of desmids. It moves with extreme sluggishness, and with little change of form. From the fore part of the body the animal was observed to project almost simultaneously a number of long, conical, acute pseudopods, about the one-twelfth of a millimetre long. From the back part in the same manner a multitude of papilliform pseudopods were projected about one-fiftieth of a millimetre long. All the pseudopods and the surface of the body everywhere bristled with innumerable minute spicules.—From time to time more or less obtuse portions of the clear ectosarc were projected, and these likewise were

observed to be covered with the minute spicules. The opacity of the animal prevented the exhibition of a nucleus, if such exists. In general appearance the curious creature resembles one of the forms of *Polyomyxa palustris*, described by Prof. Greef, in "Schultze's Archiv," vol. x. Pl. iv., Fig. 9, but in this, minute spicules project only from the posterior disc-like extremity of the body, as they have also been observed to do in the corresponding part of *Amœba villosa* of Wallich, and perhaps other species.—The general spiculate character of the Absecon amoeboid is probably sufficient to distinguish the animal generically from *Amœba*, and in this view the animal may be named *Deinamœba mirabilis*.

## BOSTON

Academy of Natural Sciences, April 8, 1874.—Mr. Bicknell in the chair.—Mr. Stodder exhibited scales of *Petrobius maritimus* and *Amathusia Horsfieldii*, to show that the so-called "beads" were the results of imperfect observation and illumination.—Mr. Bicknell exhibited and explained his achromatic condenser, made by Mr. Tolles after the design of Mr. Bicknell. Its focal distance is  $\frac{1}{15}$ , and its aperture  $150^\circ$ . Its most important variation from other condensers is in the position of the stops, the diaphragm plate being placed close to the front lens, which gives a power of controlling the illuminating ray greatly superior to that possessed by other condensers.—Mr. Samuel Wells exhibited a heliostat, remarkable chiefly for the small expense at which it was constructed. It was made from a marine clock, capable of running like a watch, in any position; the hands being removed, a pulley of  $\frac{1}{4}$  in. diameter is slipped on to the arbor of the hour-hand; on the woodwork at the top of the clock is fastened bearings for a small shaft, carrying at its upper end the plane mirror intended to follow the movement of the sun. On this shaft is a pulley one inch in diameter, deriving motion from the pulley on the hour-hand arbor by a cord. A support attached to the side of the clock carries a subsidiary mirror directly above the revolving mirror. The clock is hung on a board, hinged so as to be capable of elevation to an angle equal to the complement of the latitude. The face of the clock is turned to the north. The revolving mirror is adjusted to the declination of the sun so as to reflect the ray to the north. The ray is received on the subsidiary mirror, which reflects it in any required direction. The cost of the heliostat was less than twenty dollars, and its performance sufficiently accurate for microscopic purposes.

April 15.—The president in the chair.—Dr. Samuel Kneeland read a paper on the geology, geography, and scenery of the Union Pacific Railroad, illustrated by specimens of ores, fossils, and minerals found along the route from Cheyenne to the Sierra Nevada, with lantern illustrations of such of the scenery as best displayed the geological features.

## WELLINGTON, NEW ZEALAND

Philosophical Society, July 18, 1874.—The president, Dr. Knight, in opening the business of the evening, delivered an address, which passed in review the various questions discussed at the society's meetings during the past year. Its main feature was a dissertation upon certain peculiarities in the climate of New Zealand, and the evidences which, in the opinion of the president, proved the former existence of glacial periods in the southern hemisphere just as in the northern, but occurring alternately. The effect of ice in producing surface features had, in his opinion, been greatly overrated, and following up this opinion the president explained that the great ice sheets, several thousand feet in thickness, which the ice theorists required, could not have existed, as the pressure of the mass of ice would melt the lower stratum.

July 25, 1874.—Dr. Hector drew attention to the articles with which the museum had been enriched by the officers of H.M.S. *Challenger*. These consisted of specimens of different fishes, &c.—Mr. J. C. Crawford read a paper on the question, "Did the great Cook Strait River run N.W. or S.E.?" After which Mr. Hood read a paper on the hot winds of Australia having influence on the climate of New Zealand.

Aug. 8, 1874.—Mr. Travers read a letter from Capt. Turnbull, harbour master at Hokiitika, to the Hon. J. A. Bonar, superintendent, descriptive of a portion of wreck found at the Haasi, on the west coast of the Middle Island. This fragment was found at a great distance from the present high-water mark, surrounded by dense bush. It was discovered by diggers in 1867. Dr. Hector said that in 1867 he had called attention to the wreck. The most important point was the distance

from high-water mark at which it had been found, which was fully 300 yards. It was surrounded by low scrub, the terraces behind being heavily timbered. This proved that the high-water mark at that time must have been very different from what it is at present. Capt. Fraser suggested that it might be a portion of La Perouse's ship, which had for many years been sought in vain.—Dr. Hector then read an interesting paper on the Summer Cave, in Canterbury, New Zealand, by Mr. A. McKay, of the Geological Department, who had made excavations there for Dr. Haast in 1872. The exploration occupied seven weeks, and on its completion the collections and notes which were made were given to Dr. Haast, and the paper now read was chiefly occupied with the author's own views on the question—whether the moa hunters were possessed of tools other than those of the rudest description; and whether there were any facts constituting a difference between them and the Maoris of later times. After discussing the relative age of the moa ovens at the Rakaiia and elsewhere, the author considered the Summer Cave to be the oldest. While the evidence obtained does not show that the moa hunters were in any way different from the Maoris, he yet considered the period of the cave deposits as much more remote than the traditional date of the first arrival of the Maoris in New Zealand—350 years ago—and thought that probably 1,350 years would be nearer the mark. He considered the asserted absence of any traditional knowledge of the moa amongst the Maoris showed that the moa was exterminated either by a different race, or that the Maoris arrived at a date long prior to which their traditions extend. Mr. Travers mentioned as an interesting fact, that there was a family of cave-men living in a cave at Port Nicholson, which was situate at less than a mile from the Pilot Station at the Heads. There were six or seven Maoris living there, and he had frequently visited them. Dr. Hector said that the only grounds Mr. McKay had for doubt as to the recent date of the moa's existence, seemed to be the absence of Maori traditions with regard to it. He could only say that modern Maoris seemed to know all about it. On the whole, he thought there was no reason for jumping to the conclusion that the moa had become extinct at a very remote period. The positive evidence of the existence of the moa in New Zealand was probably greater than that of the existence of the emu in some parts of Victoria. Many persons were not conversant with the rapidity with which animals disappear. In proof of this he would refer to the bison. A hundred and fifty years ago these animals roamed over the Eastern States in countless herds; yet it would now be very difficult to obtain positive proof of their former existence in those States.—Dr. Hector read a paper on the Tertiary series of Wanganui, by Mr. Purnell, and observed that the paper pointed out an unconformity in breaking up the lower Wanganui series, which, if established, would have an important bearing on the geology of the district.

Aug. 15, 1874.—On the alleged Pleistocene glaciation of New Zealand, by Mr. W. T. L. Travers, F.L.S. This paper was devoted to the discussion and refutation of the theory, advanced by Dr. Haast in various reports and addresses, that during the Pleistocene period the physical condition of these islands resembled that of Greenland, where the country is covered with an ice sheet, and glaciers protrude into the sea and break off to form icebergs. After showing that such a view is inconsistent with the evidence afforded by the existing and extinct fauna and flora of the country, the author argued that the former extension of the glaciers was due to a great elevation of the islands that followed the close of the Miocene period, to an altitude exceeding its present elevation by four or five thousand feet, and that the ensuing retreat of the glaciers was due to subsequent depression, the extent of which exceeded the former maximum elevation, and that in post-pleistocene times there has been a slight re-elevation with a corresponding re-advance of the glaciers in the valleys radiating from the chief mountain centres, such as Mount Cook.

## VIENNA

Imperial Academy of Sciences, Dec. 3, 1874.—Herr K. Fritsch presented a memoir on the yearly periods in the insect-fauna of the Austro-Hungarian Empire, treating in detail of the yearly distribution and periodicity of appearance of insects, together with an account of meteorological influences upon them.—Capt. Volkmer communicated a note on the drinking waters of Vienna.—Dr. Daubrawa transmitted a paper on some pendulum experiments.—Herr Gruber gave an account of a "coincidence" apparatus for the determination of gravity; it was used with great success for geographical measurements during 1874.

Dec. 10, 1874.—Herr von Willerstorff-Urbair reported on the meteorological observations made by Schiffslieutenant Weyprecht, during the Austrian North Polar Expedition.—Herr Dr. Steindachner communicated a paper on the river-fishes of the south-eastern coast district of Brazil, from the mouth of the La Plata to that of the San Francisco.—Director von Littrow read a telegram from the observers of the Transit of Venus at Jassy, where the egress was successfully observed.

Dec. 17, 1874.—Prof. von Ettingshausen transmitted a paper entitled "The Genetic Organisation of the Flora of Australia."—Prof. Lieben communicated some notes on the oxidation products of camphor, and also an analysis of the mineral waters of Poschitz.—Prof. Puschl gave an account of the properties of saturated vapours.—Director Stefan read a paper on the laws of magnetic and electric forces in magnetic and dielectric media, and their relation to the theory of light.—Oberlieutenant Jul. Payer then gave an account of his sledge expeditions in Franz-Joseph's Land, with special reference to the character of its hills, glaciers, vegetation, and animal life.—Dr. Holetschek communicated the elements and ephemerides of Comet VI., 1874, discovered by Borrelly at Marseilles on Dec. 6.

## PARIS

Academy of Sciences, March 8.—M. Frémy in the chair.—The President, in speaking of the sad loss the Academy has sustained in the death of one of its most eminent members, M. Mathieu, to whom they had just paid their last tribute of respect by attending his funeral, proposed, in honour of the deceased, to adjourn the meeting.—M. Broch then made a speech in the name of the Commission du Mètre, of which M. Mathieu was the president.—The meeting was then adjourned.—Four letters relating to the Transit of Venus were received, viz. 1.—From M. Fleuriaux, dated Pekin, Jan. 5, 1875, giving the complete details of the observations made at that station, and containing an account of further scientific researches made during the time the severe cold detained the observers at Pekin, the rivers not being navigable; from M. Mouchez, dated Dec. 13, 1874, with an account of the observations made on the Island of St. Paul; from M. Bouquet de la Grye, who will shortly arrive in Paris; lastly, from M. André, who reports that he could only observe one internal contact, and that he resolved to prolong his sojourn at Nouméa to make exact determinations of the longitude of that place.

## BOOKS AND PAMPHLETS RECEIVED

BRITISH.—Practical Guide to the Determination of Minerals by the Blow-pipe: Dr. E. W. C. Fuchs. Translated by T. W. Danby, M.A., F.G.S. (Field and Tuer).—Watford Natural History Society and Hertfordshire Field Club's Laws and List of Members.—The Development Law of the Earth: Prof. Bernhard von Cotta. Translated by R. R. Noel (Williams and Norgate).—St. Helena: a Physical, Historical, and Topographical. Description of the Island: John C. Melliss, A.I.C.E., F.G.S., F.L.S. (Lovell Reel).—Report of the Proceedings of the Conference on Maritime Meteorology held in London 1874 (H.M. Stationery Office).—Memor of the Life and Labours of the Rev. Jeremiah Horrox: Rev. A. B. Whiston, B.A., LL.D. (William Hunt and Co.).—Manchester Field Naturalists' Society. Report of the Committee for the year 1874, with Accounts of the Excursions.

## CONTENTS

	PAGE
LUBROCK'S "ORIGIN OF CIVILISATION" . . . . .	401
KINAHAN'S "VALLEYS, FISSURES, FRACTURES, AND FAULTS" . . . . .	403
OUR BOOK SHELF—	
Renshaw's "Cone and its Sections" . . . . .	404
Markham's "Whaling Cruise" . . . . .	404
LETTERS TO THE EDITOR—	
Antares—S. W. BURNHAM . . . . .	405
Storm Warnings from the United States.—W. CLEMENT LEV . . . . .	405
Meteorological Observations in the Pacific.—REV. S. J. WHITMEE . . . . .	405
Struck by Lightning.—D. PUDRON . . . . .	405
Mr. G. DARWIN'S PAPER ON COUSIN MATRAGES.—GEORGE DARWIN . . . . .	405
Mounting Acari for the Microscope.—W. SAVILLE-KENT . . . . .	406
The "Wolf" in the Violoncello.—HERBERT F. FRYER . . . . .	406
Coloured Shadows.—C. T. L. WHITMELL . . . . .	406
OUR ASTRONOMICAL COLUMN—	
Anthem's Star of 1870 (11 Vulpecule) . . . . .	407
Meteor-shower of October Ad. 853 . . . . .	407
Comet 1840, III. . . . .	407
THE BIRDS OF BORNEO . . . . .	407
PHENOLOGICAL PHENOMENA . . . . .	408
INSTITUTION OF NAVAL ARCHITECTS ( <i>With Illustration</i> ) . . . . .	408
THE FARADAY LECTURE . . . . .	411
NOTES . . . . .	412
SCIENTIFIC REPORT OF THE AUSTRO-HUNGARIAN NORTH POLAR EXPEDITION OF 1872-74, III. . . . .	415
SCIENTIFIC SERIALS . . . . .	416
SOCIETIES AND ACADEMIES . . . . .	417
BOOKS AND PAMPHLETS RECEIVED . . . . .	420



THURSDAY, APRIL 1, 1875

## DEEP-SEA FISHING

*Deep-Sea Fishing and Fishing Boats. An Account of the Practical Working of the various Fisheries around the British Islands.* With Illustrations, &c. By Edmund W. H. Holdsworth, F.L.S., &c., late Secretary to the Royal Sea Fisheries Commission. (London: Edward Stanford, Charing Cross, 1874.)

MR. HOLDSWORTH, having officiated as secretary to the Royal Commissioners who inquired into the state of the British fisheries in 1863, and whose report was presented to Parliament in 1866, has had access to the very best information and to people who have all the "ins and outs" of the fisheries at their fingers' ends. As might be expected, therefore, from the opportunities of its author, this is an excellent work of its kind, forming a complete directory to the fishing ports of Great Britain and Ireland; and persons about to embark in any kind of fishery enterprise could not have a better guide. Although the author makes no parade of being scientific, and has no pretension to unfold other than an unvarnished tale of our fishery resources, the book is not devoid of interest for scientific persons, seeing that it contains some account of Prof. Sars' discoveries with regard to the floating of fish spawn. Moreover, Mr. Holdsworth's work appears opportunely enough, seeing that the daily newspapers are indulging in discussions regarding oyster-spat, over-dredging, and cognate subjects.

The question of "over-fishing" is of the first importance, because we are dependent on the sea for a vast proportion of our food supplies. On this subject the author of "Deep-Sea Fishing" is evidently at one with his late masters, but in discussing it he is compelled to admit a large increase in the machinery of capture; indeed, the book is very much a record of that fishery improvement which, so far as the catching apparatus is concerned, has now become pretty general. Although it is wise to accept, discuss, and analyse all the information we are able to lay hands upon which bears on the question of our daily supplies of food, we shall not at present say more about "over-fishing;" so far as that question is incidentally alluded to by Mr. Holdsworth, than that his inferences and his facts are very much at variance. Put in a nutshell, nothing can withstand the logic of the case for those who say we are "over-fishing;" it is, that the supply of fish being equal to what it was, an increased number of boats and an improved mode of capture, with constant multiplication of the apparatus of capture, should, in a given ratio, add to the supplies of fish which are brought to market. Issue has been joined between those who say our fisheries are not so productive as they ought to be, and those who aver that we are "over-fishing;" and, so far as the evidence we have seen goes, the latter party have, we think, the best of the argument.

It is of the greatest importance to the present and future of our fisheries that we should fish with economy, and, above all, that we should fish in such a manner as will not wantonly waste the spawn of our best table fishes. At present the waste of spawn, through the capture of gravid and

immature fish, is so enormous as to be incalculable. It has been said of the salmon, that although an individual may be of the value of ten shillings per pound weight on a Bond-street counter, it is worth five times that price when it is on the spawning "pedds." The same may be said of all fish, even of those which we least esteem for food purposes. In times past, fish have been held so cheap, in consequence of the liberal ideas which were prevalent as to their great abundance, that men thought it of no importance whether the fish they ate were or were not full of spawn; indeed, customers thought themselves rather ill-treated when their fish-merchant sent them a fish without its roe; and, as a rule, fishmongers cannot do otherwise than send "full fish" to all who purchase, for the very excellent reason that it is at the season when they are about to become reproductive that man obtains easy access to them. It is also the season when they are most unfit for food. No grazier or cattle-feeder in his right mind would kill a cow when large with calf, or a mare big with foal. And putting the case another way, if all our oxen were killed as calves, and our sheep while they were lambs, should we not very speedily be on the verge of famine? Yet these are the modes of doing business which prevail in our fisheries. It is well that the inhabitants of the sea are so prolific in their seasons of reproductiveness; were they less so than they are, a very few years would exhaust even the productive cod banks of Newfoundland.

As regards salmon, the percentage of eggs which come to life and yield fish is pretty well known, as is also the percentage of young fish which is destroyed. The number of salmon (*Salmo salar*) which escape infantile perils and become reproductive is very small, not ten per cent. Out of every hundred eggs spawned in the natural state, it may be calculated that at least one-third escape the action of the fecundating milt, that another third never, from various causes, come to life, which leaves only one-third to produce fish; and of the thirty-three tiny animals thus left, a full half will be killed by enemies, which are numerous, leaving, say, sixteen young smolts to become grilse, and as these have to make one voyage to the sea, or probably two, before they become reproductive, their number in the end becomes sadly reduced, so reduced that probably not five of them will be able to repeat the story of their birth and so provide future supplies. If the mortality incident to fish life be so great in a salmon river, what must it not be in the ravening depths of the ocean? A large cod-fish we know yields more than a million of eggs, but when we consider the fact of these eggs being entrusted to the boisterous waves of the sea, we have little hope that the yield of reproducing fish will be greater than in the case of the salmon, which enjoys the comparative tranquillity of inland streams. Much ignorance has hitherto prevailed as to how fish spawn. The salmon we have been able to watch day by day, and to note every action whilst it is engaged in that great function of its nature, and we also know a little about the reproduction of the herring, but as regards the reproductive *modus operandi* of our larger sea-fish, much that we know, or think we know, is only the result of guessing or of reasoning from analogy. M. Sars has discovered that the ova of some fishes, notably the ova of the cod (*Gadus morrhua*) and of the plaice

(*Pleuronectes platessa*), are hatched whilst floating on the waves. Ova of these and other fishes have been found floating in different stages of development. There is no doubt of this fact, and in some of the larger rivers of China the spawn of fishes is known to float on the surface, for it is collected at certain places for piscicultural purposes, by means of bunches of grass and soft matting. These, it is known, become the recipients of large numbers of fish eggs, and are easily removed to other waters; which, being barren of fish, are in this mode repopulated. There cannot, we think, be a doubt that various fishes spawn in various places, some at the bottom of the sea, some on the surface; and it is very likely, by this diversity, that the varied species are best preserved. The herring (*Clupea harengus*), and probably all its congeners (but this is not quite certain), spawn on the bottom, and the eggs remain there, adhering in masses to the rocks and stones. The eggs of the salmon, we know, when not washed away during deposition by flooded water, sink, by means of their weight, to the bottom, where the parent fish instinctively covers them up with gravel in order to protect them from their numerous enemies. Most sea-fish, we have a strong impression, emit their spawn in the same manner, whatever future direction it may take in the way of motion. All the fish eggs which we have seen gathered from the surface of the water were almost at maturity; and the late Mr. Robert Buist, of the Tay fisheries, informed the writer that he had seen salmon eggs, as the time approached for the eclosion of the fish, rise to the top of the water in the breeding boxes at Stormontfield, but they always sank again before the birth of the fish.

What practical bearing has all this on the economy of our fisheries? will be asked. There is one point which Mr. Holdsworth makes in detailing M. Sars' discoveries, and it is, briefly stated, "what becomes of all the complaints against the beam trawl net"? That ponderous instrument, as all of us are aware, has been accused of breaking up the spawning beds and killing the fry; but naturally, if there is truth in the discoveries of M. Sars, and if the spawn float on the waves, that accusation must fall to the ground. That the trawl net "hashes" the fish which it captures, and destroys a large number that it does not capture, is well known, but not any of our modes of fishing are perfect. It is not possible to dictate to the fish as to which are to enter or stay out of the death chamber. Nor, if a hundred hooks be set with bait for the line fishery, can we dictate as to what size of cod-fish or haddocks should take the hook. One thing we can do: we can reject all fish which are of insufficient size or have not had an opportunity of multiplying their kind. Most of the line fish when taken on board are alive, and also a large percentage of fish that are trawled. Those which are too small might be restored to their native element. We are ourselves recommending this plan. So far as we understand Mr. Holdsworth, he only confines himself to an exposition of how we fish: as to how we *should* fish he is silent; in fact, he is satisfied with the deliverance of the Royal Commission of 1863, of which he was the secretary, that our fish supplies have increased and are likely still further to increase. We should not in the least object if the increased supplies kept pace with the augmented machinery of capture.

## JARDINE'S "PSYCHOLOGY OF COGNITION"

*The Elements of the Psychology of Cognition.* By Robert Jardine, B.D., D.Sc., Principal of the General Assembly's College, Calcutta, and Fellow of the University of Calcutta. (Macmillan and Co., 1874.)

MR. JARDINE has seemingly had some personal reason for writing this treatise; for in the preface he asks the critic to bear in mind "that the book has been written with considerable haste, in order to secure its publication within a certain limited time." It would have been wiser to ignore the critic: for this unsympathetic personage is only too certain to meet this innocent confidence with the unfeeling remark that perhaps the interests of science would not have suffered had the author taken a little more time over his work. Had nothing been done before Mr. Jardine began to write "to show the inadequacy and unsatisfactoriness of a prevailing system of psychology," he would have required to make a much more thorough and more direct attack on the teachings of Mr. Mill and Prof. Bain, in order to accomplish "one principal object" that he had in view. Again, we think Mr. Jardine would have better consulted the interests of his readers generally, including the "students," for whom the book was "principally designed," had he made more explicit reference to the writers to whom he is indebted for the weapons he has employed in this attack on "phenomenalism." Another general criticism that must be made is, that there is not a sufficient wealth of concrete illustration, and that, though the writer has "endeavoured to express himself in as clear and simple language as possible," his words are, nevertheless, often dark and difficult enough. What will readers "beginning their philosophical studies" make of such a sentence as this?—"It must be borne in mind that it is in their character as modes of the non-ego that objectified sensations are localised. The localising is, therefore, not so much an act of consciousness as a precept of consciousness and a form of the non-ego."

We do not find it easy to review this book fairly. For one thing, the author has no personality; then, while on the one hand it would be very easy to speak of the excellence of many pieces of exposition, on the other hand nothing could be easier than to select a few passages for unmitigated censure. On the strength, for example, of the following sentence, one might almost question the claim of the writer to rank as a scientific student of the subject on which he has written:—"In the scientific mind of modern times," says Mr. Jardine, "there has arisen, through the influence of a long-continued and exclusive study of phenomena, a predisposition to doubt the occurrence of events which are plainly beyond the sphere of phenomenal laws." The worst of it is that long before we reach this sentence, which occurs near the end of the book, we have come to regard Mr. Jardine as a man of such respectable ability that we have the greatest difficulty in believing that he can really think that anything he has said can carry him a single step towards the goal he now seems anxious to reach. The scientific men of modern times are innocent enough of having their minds "vitiated by the prevailing phenomenalism" represented by Mr. Mill and Prof. Bain. They have indulged in an exclusive

study of phenomena for the very sufficient reason that they can never get at anything else. In justice to the author, however, it must be said that he several times gives pretty distinct evidence that he has never quite grasped the question at issue between our modern realists and idealists. Compare the following sentences with the one just criticised:—"Light, heat, electricity, force, as studied by physicists, are non-phenomenal powers, and the object of science is to ascertain their laws and relations." "Realism, as found in Herbert Spencer, and as supported by recent investigations of science, demands a belief in real objective non-phenomenal forces." Mr. Jardine does not tell us, and we cannot conceive, what recent scientific investigations he could have been thinking of; but that he should suppose that Mr. Spencer's doctrine of the unknowable could be supported by any recent discoveries, or by anything ever to be discovered, shows conclusively that he has still to learn what that doctrine really is.

We agree with Mr. Jardine in rejecting the idealism of Mr. Mill; and we must say that some of Mr. Jardine's criticisms are very happy. Here is an example. Mr. Mill says that the possibilities of sensation that make up a given group "are conceived as standing to the actual sensations in the relation of a cause to its effects." On this Mr. Jardine remarks: "We have, for example, the sensation of a particular figured colour, which is associated with the name orange. Connected with this sensation there are a number of possible sensations of smell, taste, touch, sound, &c. *The possibility of those sensations is the cause of the colour.* What does this mean? Is the possibility of a smell the cause of a colour? Is the possibility of a taste the cause of a colour? Or is the possibility of all the other sensations of the group taken together the cause of colour?" No doubt some of Mr. Mill's disciples may object that Mr. Jardine has misunderstood Mr. Mill; they will, however, find it hard to give any definite meaning to the words of their master without either making him a realist or letting in some such criticism as the above.

But though we cannot always agree with Mr. Mill, we can never think of him without feelings of profound admiration and respect. We have therefore no sympathy with Mr. Jardine when he tells us how easy it is "to show the absurdity" of Mr. Mill's attempt to explain our notion of extension. A more modest self-appreciation in the presence of Mr. Mill would have been becoming; the more so as Mr. Jardine has none of that cleverness of expression which may at times do something to cover the audacity of the critic. Mr. Mill will not fall before the word "absurdity"; and Mr. G. H. Lewes will not be seriously damaged by being loosely classed with "a set of visionary speculators called phrenologists," who, acting upon a "hasty and crude hypothesis," have made a very great blunder.

There only remains to say that Mr. Jardine seems to be himself unacquainted with the psychology of our own day. He may sneer at Mr. Lewes for giving "prominence to the study of physiology as a means of becoming acquainted with mental laws," but if he would entitle himself even to a hearing, he must, as a first condition, make himself master of the knowledge that has been laboriously acquired by the school of investigators to which Mr. Lewes belongs.

DOUGLAS A. SPALDING

### WHITE'S "SELBORNE"

*White's Natural History of Selborne.* Edited by J. E. Harting, F.L.S. Illustrated by Bewick. (London: Bickers and Co., 1875.)

ALTHOUGH we have no evidence that, within the last century, there has been any considerable change in the average standard of human mental power amongst civilised nations, the surroundings of every-day life have so greatly altered, both in their quality and in the rapidity of their occurrence, that the standard of ordinary existence has undergone a corresponding modification. The introduction of steam locomotion, the electric telegraph, and the penny post have developed such a condition of unrest in humanity at large that the unalloyed repose of a continuous rural life is rarely sought for, and as infrequently obtainable. We can hardly conceive it possible that anyone, such as a life-fellow of a college, as was Gilbert White, of Oriel, Oxford, should at the present day settle down in any out-of-the-way part of the country, satisfied with nothing more than an opportunity of observing and recording the surrounding phenomena of nature. More would be expected of him, and he would be continually led to feel that he was but one of the instances of the vegetating influence of an antiquated system, whose advantages were being daily disproved by his individual existence.

The same influences have affected the mental world. Facts have a less intrinsic value than they used to have in the time of Gilbert White, the Addition of natural phenomena. More must now be extracted from them in their mutual relations. They must be manipulated into the web of some inclusive hypothesis, or otherwise they may as well die an unrecorded death, because their independence only helps to block the already but too narrow path which leads towards omniscience. In this period of revulsion against encyclopædic knowledge, a remark by the author of the work before us, when writing of the otter, indicates a tenour of thought which is antiquated, to say the least. "Not supposing that we had any of those beasts in our shallow brooks, I was much pleased to see a male otter brought to me, weighing twenty-one pounds, that had been shot on the bank of our stream below the Priory, where the rivulet divides the parish of Selborne from Harteley Wood." No inference is drawn, no comment made; whence the source of pleasure?

We cannot well conceive a more efficient editor, at the present time, than Mr. Harting. That author's considerable experience and his great love for the study of the ornithic fauna of the British Isles has already made his name well known in connection with the birds which reside amongst us, and those which visit our shores. He also tells us in his preface, as may be equally well inferred from his annotations throughout the work, that he is well acquainted with the neighbourhood of Selborne, which enables him to correct a few of Gilbert White's inaccuracies, and bring to the foreground those slight changes in the fauna and flora of the district which have occurred since the book was originally written. Amongst the latter, special attention is directed to the reintroduction into Wolmer Forest, by Sir Charles Taylor, of black game, "which I (Gilbert White) have heard old people say abounded much before shooting flying became so com-

mon"; and the non-applicability to present visitors to the Devil's Dyke, of the remark that "there are busters on the wide downs near Brighthelmstone"; and to those who spend their summer at Eastbourne, that "Cornish choughs abound and breed on Beachy Head, and on all the cliffs of the Sussex coast." A lengthy list of references is given with regard to the habits of the cuckoo, a subject on which further reliable information is much needed.

The typography, paper, and binding of the work are all that can be desired, and Bewick's drawings add further to its general interest.

### OUR BOOK SHELF

*Microscopical Notes regarding the Fungi present in Opium Blight.* By D. D. Cunningham, M.B., Surgeon H.M. Indian Medical Service. (Calcutta: Office of the Superintendent of Government Printing, 1875.)

DR. CUNNINGHAM has devoted much care and attention to the study of the fungi present in the opium blight, and the results of his labours are given in the present pamphlet. The most important fungus present, and the one really causing the blight, is a species of *Peronospora*, and thus belongs to the same genus as our own too well-known potato-disease fungus. As in India the *Peronospora* affects the opium crop very seriously, it is a matter of the highest importance to have the life-history of such a pest worked out thoroughly by a competent observer. The *Peronospora arborescens*, which in India attacks the opium poppy, is to be met with in this country on the red poppy (*Papaver Rhæas*). Dr. Cunningham invariably found the *Peronospora* present in blighted leaves, and he describes fully the mycelium and the conidia of the fungus. The mycelium spreads through the intercellular spaces of the leaf, branches coming to the surface through the stomata, which ramify and produce the conidia. The conidia apparently do not produce zoospores. The sexual mode of reproduction by antheridia and oogonia was not observed, even although De Bary has already described the oogonia of this fungus. The life-history thus is imperfect, and we must urge Dr. Cunningham to persevere and not rest satisfied until he has observed the whole of the stages of this fungus.

After the parasite has done its work, the leaves of the poppy become infested with a number of other fungi, chiefly saprophytes, and Dr. Cunningham carefully describes and figures several of the forms.

W. R. M'NAB

*Logarithmic and Trigonometrical Tables for Approximate Calculation.* By J. T. Bottomley, M.A., F.R.S.E. (London and Glasgow: Collins and Co., 1875.)

THESE tables were primarily arranged by Mr. Bottomley for the use of the students of the Natural Philosophy Class in Glasgow University, but we believe many other students will feel grateful to the author for having published them.

AN easy, handy book of tables such as this has been much wanted for Mathematical and Natural Philosophy Classes in the Universities and for advanced schools. There is no reason why, with a really convenient book, boys should not all learn logarithmic arithmetic as soon as they know decimals. But the books hitherto in use are too formidable. Moreover, practical calculators will find much use for four-figure logarithms, sines, &c., and many people who never use logarithms will be able to do so with ease when they have a four-figure table.

Mr. Bottomley has in this manual arranged (on the plan of De Morgan, we believe, who first applied it to logarithms) sines, tangents, logarithmic sines, and loga-

arithmic tangents, and has printed them, with the logarithms and antilogarithms, each table on two facing pages.

We heartily approve of Mr. Bottomley's plan, and recommend his manual to all teachers and students who wish for an easily consulted scientific ready reckoner.

### LETTERS TO THE EDITOR

[The Editor does not hold himself responsible for opinions expressed by his correspondents. Neither can he undertake to return, or to correspond with the writers of, rejected manuscripts. No notice is taken of anonymous communications.]

#### A Gyrostat Problem.\*—Answer

LET  $W$  be the weight of the fly-wheel.

$k$  its radius of gyration.

$\omega$  its angular velocity in radians per second.

$W'$  the weight of wheel and case together.

$a$  the distance from the centre of inertia to the point of attachment of the string.

$g$  the force of gravity.

The moment of momentum of the wheel round its axis is  $\omega Wk^2$ .

The rate of generation of moment of momentum round a horizontal axis perpendicular to the axis of the wheel, by the couple produced by the action of gravity and the tension of the cord by which the gyrostat is suspended, is equal to the moment

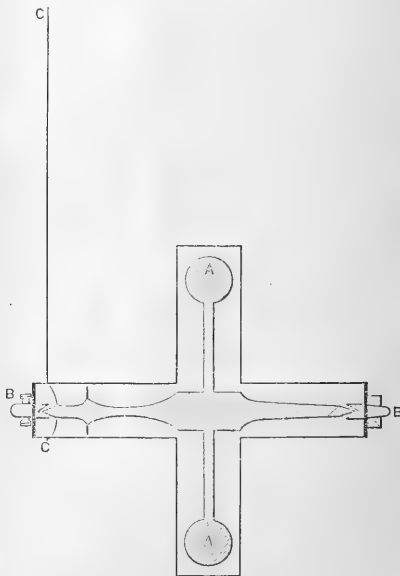

of the couple (see Thomson and Tait's "Elements of Natural Philosophy," § 236), and is therefore,  $g W' a$ . Therefore the moment of momentum generated in a small time  $\tau$  is  $g W' a \tau$ .

Compounding these two moments of momentum by the parallelogram of moments, we obtain—

$$\tan \theta = \frac{g W' a \tau}{\omega W k^2}$$

where  $\theta$  is the angle described in azimuth by the axis of the wheel in the small time  $\tau$ ; and since, when  $\theta$  is small,  $\tan \theta = \theta$ , we have by the question—

$$\frac{g W' a \tau}{\omega W k^2} = \frac{1}{4} \tau$$

\* For Problem, see NATURE, vol. xi. p. 385.

Hence  $\omega = \frac{4gW'a}{Wl^2}$  in radians per second.

Hence number of revolutions per second =  $\frac{2gW'a}{\pi Wl^2}$

Substituting the numbers given in the question, we have for the answer—

$$\frac{2 \times 981.4 \times 2250 \times 6}{3.1416 \times 1800 \times 16} \\ = 293 \text{ revolutions per second.}$$

University, Glasgow

D. M'FARLANE

### The Sounds of the String Organ

MR. BAILLIE HAMILTON'S invention of a conjoined string and reed which is now being carried out in a musical instrument to be called the string organ, has caused a marked interest both in its musical and in its scientific aspects. My attention was attracted to it strongly, for one reason, that it promised to add a new member to the family of keyboard instruments, and for another reason, that the study of its possibilities and practical working showed conditions so close in analogy to those of the organ-pipe as viewed under the theory advanced by me in NATURE, that the corroborative evidence thus furnished might with truth be called palpable. By the last word I refer to the visible displacement and travelling of the node, which can be affected at will in obedience to changes in the relative conditions of reed and string. I find that "tension" on the string is equivalent to "scale" in organ-pipes. To give high tension to a string is in effect the same as to use a narrow scale of pipe; thus, keeping the reed-force constant, we may respectively, by giving higher tension to the string, or by using a narrower pipe, drive the node higher, and conversely, slackening tension or using a wider scale of pipe, we may displace the node to a lower position. In the conjoined reed and string we can see this change taking place, order how it shall take place, and may clip the nodal point with our fingers without disturbance of the continuity of vibrations. The process is visible, the result tangible.

The estimate Lord Rayleigh\* has given of the instrument as "modified reed" is undoubtedly right, yet it can scarcely be said that the opposition estimate is undoubtedly wrong. An orthodox organ is a pipe-instrument, and also is a wind-instrument, yet in acoustical relations the pipe is out of theoretical conformity, is a modified pipe; the air-reed likewise, according to the kind of pipe it is allied with, is a modified reed, and similarly in this novel organ the string and reed modify each other; sever the union, and the manifestations of the two independent forces will be wholly different. Specifically it is a wind-instrument, and I cannot but think we should admit it to be both "modified reed" and "modified string;" they work together as a system, each contributing its own character, and each in degree determining, through compromise and affinity, the issue of the union. Strongly impressed with this belief, my explanations will consequently differ from those generally current concerning this ingenious combination.

Lord Rayleigh, in explanation of his estimate, says, "the intermittent stream of air, which does not take its motion from the reed, gives rise to a highly compound musical note." Either I do not understand this affirmation, or I misunderstand it; I have always considered the intermittence of the stream to be the result of the reed's motion. And further on, another sentence to strengthen his distinction: "The fact that the pitch of the system is mainly dependent upon the string seems to have distracted attention from the important part played by the stream of air, and yet it is obvious that wind cannot be forced through such a passage as the reed affords without the production of sound." Speaking, not without experience in varieties of free reeds, I cannot recall a single instance of the wind forced through the passage afforded by the reed producing anything like a musical sound. Our views probably differ in expression and in interpretation more than in perception.

With some temerity I think I may say that the working of the free reed is not fairly estimated by scientific observers. It is generally supposed that the pressure of the wind originates the vibration of the reed in instruments, whereas the fact is that the free reed may be so set that although perfectly free to pass, as may be seen on holding it up to the light, perfectly free to sound, as may be proved by percussion, yet, placed within the instrument, it will be dumb to all pressure of the wind. The essential condition for speech is for the reed to be so set that a

sufficient amount of air shall with velocity pass the sides and through the mortice of the reed equal to causing a suction on the under side of the reed; then only will the reed proceed on its course, and the check given to the stream when the reed reaches the level of the block intensifies the suction, the development whereof progresses until the back-lash or return of the reed creates a stronger partial vacuum with a promptness of power effectual for establishing the condition of vibration. There are peculiarities, too, in the process of the suction, not lightly to be passed over by the scientific observer. The true test of action is the degree of quickness in speech. The most prompt articulation is that in which the process of suction is most gradual; this is not paradoxical, though it may seem so. If a large amount of wind is allowed to pass, the action will be sudden, yet, notwithstanding, the speech, comparatively estimated, will be slow. The suction should first attack the tip of the reed and gradually draw upon the stem. If you allow passage to the wind near the root of the reed, or if you hollow or arch the stem, permitting wind more freely to pass the middle of the reed, it is inevitably at the sacrifice of quickness of speech, and nothing is more fatal than allowing extra opening for a rush of air between the tip of the reed and the frame, for you thereby impair the perfectness of the suction at its most vital point.

In the case of a reed and string conjoined, the string is a weight to be moved; the force of wind will effect the displacement if the string has held the reed in position to allow passage of wind; and when the equilibrium of the string has been in the least degree disturbed, the return motion becomes a source of additional impetus, inducing the reed to follow by reciprocation; yet even here we do not escape the demand for suction; the value for this purpose of a tube or a channel beyond the reed is as evident as in the harmonium. The difference between the modern harmonium and the old seraphine is, that the former has pipes or channels to every reed, the latter had its reeds placed over apertures in plain boards; the reed conjoined to a string when so placed over a simple aperture will sound as would the reed in the old seraphine, but generally with the exhibition of the same defect, slowness of speech. Select an instance of such a string and reed so sluggish that the attainment of speech to the semblance of a musical note is a trial of patience; then add a tube of suitable character, and, in comparison of condition, the promptitude of response and power of tone will give certain evidence of its value, for here, as in all musical instruments, the function of the tube is to aid and to develop more strongly the force of suction. The suction I mean is that which is caused by the issue of a current of compressed or condensed air into the atmosphere.

A very curious problem is afforded in the peculiar quality of tone given by the new mechanical action of "reed-and-string" working linked together, and I have not heard, from any of the numerous thinkers and observers who have commented upon it, a satisfactory solution. Lord Rayleigh truly states, "it is certain that the note actually heard is compound," and also that "the peculiar character of the string, that its notes form a harmonic scale, does not come into play."

What is it, then, that we hear, and how comes this highly compound musical note into being? Let me offer this solution, if only as a suggestion. It is generally agreed that "there is a great deal of octave in the tone," sometimes the fifth, and frequently and most strikingly a beautiful major tenth, so clear that it seems to sing away by itself as if in independent existence; this, whilst it is certain that the string is not vibrating in forms either of the octave, fifth, or tenth or of any other of the accessory tones so often present to the ear. Rightly to apprehend the action of strings in musical instruments, it is, I think, desirable to regard every string as a tuning-fork acting upon the sound-board through the bridge, which, thus considered, is its stem for the communication of its vibrations. The intensity of sound from a tuning-fork or from a string depends not alone on amplitude of movement, but on pressure, the amount of such pressure being mainly determined in the case of the string by the angle the string makes in its strain upon the bridge under the particular tension to which it is subjected. A tuning-fork sounds loudly or softly, according as its stem is pressed strongly or lightly by the hand upon the sound-board. A string deflected right and left delivers each way its pulse through the bridge to the sound-board; a free reed, moving forward and backward, gives an effective impulse as musical vibration one way only—in the back-lash, or return; consequently, in this matter of conjoined reed and string, it appears to me we have always two fundamentals—two tones

\* See NATURE, vol. xi. p. 308.

having distinct powers, and either of which may take the position of root or prime; these coexistent tones, whatever the previous independent ratio of string and reed as regards pitch, will always, when thus yoked together, be one an octave higher than the other. Singularly, too, it is not necessary that the lower of these fundamentals should be the pitch-note to the ear; its apparent character may be that of a sub-tone. Generally, the higher fundamental is the leading tone, and for this reason, that the predominance of one or of the other may be determined by character and by condition. In the reed, amplitude of excursion is the measure of its attainment of strength. In the string, tension is more effectual for power than amplitude is. String-tone thus gains by limitation of excursions of the string, whilst at the same time reed-tone is at a disadvantage from the restriction imposed by tension on the play of the reed. Contrariwise with a lighter string, power may be allotted to the reed, also by tubes, by partial occlusion of orifice, by coverings or shadings, the reed-tone can be modified in a variety of degrees; it may lead in trumpet-like vigour, or be heard only in quiet undertone accompanying the higher sound.

These two notes are rigorously exact in relative pitch, and when both have intensity, although different in kind, they produce other tones, as in the stop of the organ called the "Great Quint," the tone of one pipe added to another that produces a tone a fifth higher, gives rise to a third tone an octave lower, but never perfectly, except on the same conditions, exactness of pitch and intensity, with, as a rule, the higher note voiced the strongest. The reed and string necessarily, if preceding propositions are true, being in relation an octave apart, give rise to summation tones, first to the fifth, and these again to octave, tenth, and the rest in due order, but differing in intensity. In harmonic scale those possible would be octave, twelfth, super-octave, seventeenth, &c., and so here, if reckoned from the lowest tone as the root; but summation tones seem to require for their perfect production the same conditions as named above for difference tones; so that relatively the octave becomes by its voicing the leading tone, it fixes the pitch for the series in reference to itself, and thus the ear has cognisance of the tenth, not of the seventeenth. This major tenth to the tonic, so unmistakable that it could not be gainsaid, was always a puzzle viewed as harmonic. Why it was so clear will readily be perceived when calculated as summation twice fulfilled.

The general supposition is, that because it is a string that is in action with the reed, therefore a stringy tone is in consequence obtained, the proof being that a stringy tone is actually heard. On the contrary, the true action of the string, whence arises the peculiarity of violin or violoncello, does not take place. What then? In a curious way effects are gained which naturally simulate the quality. By stringy quality musicians mean the tone of the bowed string. Amateurs talk eloquently in their way of the string-tone and its beautiful purity, of the reed-tone and its abominations, not heeding that the best judges of quality in sound class the stringy quality as the nearest allied to reed quality. Hence, organ-builders regard all the stops which best imitate the viola tube, the geigens and gambas, as decidedly reedy in character, otherwise they would be poor representatives. The violoncello's characteristic in tone has always its introductory harmonics; these are sharp to the fundamental tone in which they merge, even as, I have shown in a former paper, the harmonics of the gamba organ-pipe are. Octaves of a free-string are always sharp to the note of the whole string. Then we have also the roughness, the grip, and bite of the bow. The sharpness is minute, yet sufficiently potent to give definite character. The ear is as easily deceived as the eye—the imitation may pass for the real. If we consider what is the effect on the ear of this sharpness, which does not reach the region of beats, we shall find it to be a breezy effect; in the delicate "voix celestes" of a fine organ when finished by true artists, we have it displayed—just a freshening touch of sharpness, and no more. From a breeze to a rough wind is only gradation of similarity. Return now to the combination of reed and string: the effect as of a stringy quality is gained by the breeziness of the outward stream of air distinctly heard, by the roughness of the abrupt closing and opening of passage to a highly-excited reed, by the tendency of a highly resilient reed to a more rapid pace, curved though it inevitably is to the pace possible to the string it is paired with, thus adding an element of roughness to the sound-board, and in completeness of likeness there are the summation-tones mimicking those harmonics which are present in the fullness of the violoncello tone.

To assure those who would doubtfully accept the above interpretation, let me take an illustration of a practical nature as a verification. Why is it possible to make in a harmonium from free reeds alone a good imitation of violoncello quality? Because an analogous procedure can be adopted. This is the analysis of how it is done. Reeds of "eight-feet tone" of a firm character, rather slow in speech in consequence, but coming into play at a bound without hesitation; then in combination reeds of "sixteen-feet tone," these reeds finely curved, elastic, sensitive, quivering to a breath, their tone comes on at first as a breeze, it is sharp in a minute degree, but as the reeds gain power by amplitude, they flatten in pitch, as is the nature of bass reeds; ascending the scale, a small reed giving the twelfth may be added with advantage. In summary this is what we have: reeds relatively sharp to each other, the roughness, the breezy effect, and the accompanying harmonic offspring, together making the mimaphonic violoncello. Organ-pipe, violoncello, harmonium, and string-organ thus show a family likeness and give countenance to the interpretation.

The beauty of Mr. Hamilton's invention is that it is not limited to string-tone, that by giving predominance of power to either agent, reed or string, through long ranges of variation, many classes of tone as distinct as diapason, horn, flute, trumpet, and others can be satisfactorily imitated, and if its present promises of success are fulfilled, the name of string-organ by which it will be known will be amply justified.

HERMANN SMITH

P.S.—Mathematicians decide that the problem of the instrument is that of a loaded string. This appears to me a one-sided view, taken under limited experiments. Practically, some details of their conclusions are not corroborated; there are several elements entering into the composition not heeded, and a wider experience would show that the problem is equally that of a loaded reed. Here is an instance. I have in action a reed with pin attached; it sounds C sharp; and a string which, independently sounding, gives the F below. These, when conjoined, produce the G between. The note of the string is thus raised a whole tone; consequently the weight of the oscillating string is a load on the reed.—H. S.

#### The Law of Muscular Exhaustion and Restoration

YOUR issue of Jan. 28 is just received, containing a paper (vol. xi. p. 256) by Prof. Frank E. Nipher, wherein he condemns as "entirely unreliable" his first series of experiments on the subject of the exhaustion of the muscles of the arm by mechanical work. A like condemnation he pronounces in the February number of the *American Journal of Science*.

All the experiments in question, new as well as older, having been made at this laboratory, I beg leave to correct the above statements of Prof. Nipher. His new experiments are not so radically different from the old ones; on the contrary, both series demonstrate exactly the same general law. The true law is, as Prof. Jevons in his first communication to NATURE already felt it, logarithmic. So indeed vary most of the vital processes, because molecularly they are comparable to the vibrations of a pendulum in a resisting medium. (See Fechner, Exner, Wundt, Delboef, and others.) That the law has so long been overlooked, so far as muscular action is concerned, is probably due to the fact that the progressive restoration of the muscular tissue disturbs the function for small weights, while structural derangements (evidenced by pain) cause a like perturbation for higher values of the weight.

If we consider a system of muscles independent of continued circulation (no restoration) and keep the burden  $w$  (kgr.) low enough to cause no pain, then the time  $n$  (in seconds) during which the statical work can be sustained, or the number of times  $n$ , that the same cycle of motions can be performed until exhaustion takes place, I have found to be—

$$\left. \begin{aligned} n &= \frac{A}{B^w} \\ \text{or } \log n &= a - b w \end{aligned} \right\} \quad (1)$$

where  $\log A = a$ ;  $\log B = b$ .

In the five series at hand the following are the values of the constants:—

- |    | I.—Statical Work.                             | $a$   | $b$    |
|----|---|-------|--------|
| 1. | Prof. Jevons, Series III., holding weight ... | 2.433 | 0.1450 |
|    | II.—Dynamical Work.                           |       |        |
| 2. | Prof. Jevons, Series II., pulley and cord ... | 1.968 | 0.0476 |

3. Prof. Nipher, old series, right arm	...	...	2'080	0'126
4. " " " left arm	...	...	2'060	0'137
5. " " " new series	...	...	2'560	0'194

Also Jevons:  $a = 1'74 + 4'79\delta$ ; Nipher:  $a = 1'28 + 6'25\delta$ , very nearly.

To extend the law beyond the above physiological limits, introduce the coefficient of restoration,  $r$ , and of pain,  $\beta$ , in

$$N = (1 + r - \beta)u \quad (2)$$

where both from theory and by above series of experiments,

$$r = \frac{H}{K^w} \quad (3)$$

I have no doubt that  $\beta$  is of the same form; but none of the above series have been continued far enough to sufficiently confirm this. It is evident that  $\beta$  vanishes for small values of  $w$ , and  $r$  for large values of  $w$ .

These few remarks may be sufficient to show that the earlier as well as the late experiments of Prof. Nipher constitute a very valuable contribution to Animal Mechanics.

Iowa State University, Feb. 22 GUSTAVUS HINRICHS

The Height of Waves

YOUR correspondent Capt. William W. Kiddle, in NATURE, vol. xi. p. 386, speaking of the height of waves, says—"This remarkable gale swept over a portion of the Atlantic which the French call 'Le trou de diable.' . . . When the wind sets strongly in this direction from the north-west, the sea rises in an incredibly short space of time, and at the close of a long winter gale it is a grand sight to watch the great waves," &c. The question is then asked, why this remarkable phenomenon occurs with a north-west gale, whilst with an equally strong south-west or southerly gale the effect is insignificant?

I think an explanation may be given thus:—"Le trou de diable"—whose position, roughly calculated, is 45° N. and 40° W.—is, roundly speaking, about the centre of the Gulf Stream, in that locality, and during a strong north-west gale the wind meets the Gulf current at a good angle. The force of this encounter has a tendency to drive the stream out of its course. The velocity of the water-current and its mass are, however, so great that it yields but slightly, if at all; consequently, the force of the wind exerts itself to a large extent in banking up the water to the production of unusually high waves.

From an analogous course of reasoning, it is apparent that a south-west or southerly wind will not have a similar effect; for both stream and wind are then travelling in the same, or nearly the same, direction. The force of a gale from the south-west or south has no counter water-force to oppose it; hence its high velocity tends simply to increase that of the Gulf Stream, as well as to beat down its surface to the prevention of any extraordinary waves.

ARTHUR R. GRANVILLE

Islington, March 22

Thermometer Scales

THE thermometric scale referred to by Mr. T. Southwell (NATURE, vol. xi. p. 286) was, I believe, one used and invented by Fowler, in which 0 = 55° Fahr., 75 above = 102° Fahr., and 80 below = +5° Fahr.

The above equivalents are only approximately given. For full description, &c., see "Essays on Construction and Graduation of Thermometers," by Geo. Martine, M.D., 1772: Edinburgh.

I have failed so far in discovering the scale of Linnæus alluded to, and shall likewise feel indebted to any of your readers who will describe it.

S. G. DENTON

34, Foreign Street, Brixton, March 23

Accidental Importation of Molluscs and Insects

I OBSERVE in NATURE (vol. xi. p. 394) a note from the Saar und Mosel Zeitung on the introduction of a mollusc into the Moselle near Trèves. Though the name of the species is not mentioned, I presume that *Dreissena polymorpha* is the mollusc in question, a species known to inhabit Britain since 1824, and supposed to have been introduced with timber from Eastern or Northern Europe. It is exceedingly prolific. An instance of how this species may be introduced came under my notice a few years ago. A friend showed me some shells that he had found attached to logs of wood lying on a railway truck. These proved to be alive when put into a cup of water; and if the logs in

question had been deposited on the banks of the Tay within reach of the tide, as is often the case (I should have said that the truck was on a siding near Perth Harbour), we would no doubt have found *Dreissena* in abundance in the course of a few years. As this mollusc lives in brackish water as well as in fresh, it is no doubt in a manner similar to what I have mentioned that it has been introduced into and spread through Britain. Another shell, *Planorbis dilatatus*, a North American species, was found a few years ago living in a canal near Manchester, and is supposed to have been introduced with raw cotton. Recently another case of importation of living shells came under my notice. When looking at some sales of *Zypha* from the Nile, imported into Aberdeenshire as a material for paper manufacture, I observed some shells sticking in the dry mud adhering to the roots of the *Zypha*. On putting some of these into water they were found to be alive, though a good many months had elapsed since the *Zypha* had been gathered. The shells appear to belong to *Bythinia*, but I have not yet determined the species. It is, perhaps, not very likely that if these shells had found their way into the Aberdeenshire rivers they would have survived.

Land molluscs are sometimes introduced, and several European species have in this manner become naturalised, in North America.

Apprehensions of the fears that have been expressed that the Colorado Potato Beetle (*Doryphora decemlineata*) may be introduced into Europe and prove destructive, the Entomological Society of Belgium has been recently discussing the matter, and has arrived at the conclusion that the fears regarding this insect are much exaggerated. M. Oswald de Kerchove, of Denterghem, has just published a very complete memoir upon this beetle. He thinks that it is very improbable that the *Doryphora* will be introduced, and at any rate that the prohibition of the importation of American potatoes is unnecessary, as it lives upon many other plants than *Solanaceæ*. M. de Kerchove further depreciates the use of the arsenite of copper (Scheele's green), so much employed by the Americans for the destruction of the beetle, as such a dangerous substance ought not to be made common.

It is not the "Blood Louse," so destructive to apple-trees, mentioned by the *Kölnische Zeitung* (NATURE, &c.), the homopterous *Eriosoma lanigerum*, the so-called American Bug, already too well known in this country?

Perth

F. BUCHANAN WHITE

Fall of a Meteor at Orleans

IN the "Notes" of March 18 (vol. xi. p. 396) it is stated that a meteor fell in a street at Orleans on the 9th inst. The time of the fall is not mentioned, but it would be interesting to know if the meteor were the same that was observed from here on the evening of that day about eight o'clock. It was very brilliant, as bright as Sirius, and moved slowly from a position a few degrees to the east of Sirius, in a south-easterly direction, the path making with the horizon an angle of about 60°.

Cooper's Hill, March 27

HERBERT M'LEOD

Proposed Aquarium in Edinburgh

I AM happy to be able to inform you that the suggestion originally made in NATURE, that a large aquarium should be formed in Edinburgh, is likely soon to be adopted. A company named the "Edinburgh Winter-Garden, Theatre, and Aquarium Company (Limited)" proposes to provide at the west end of Edinburgh a large and well-stocked aquarium on a scale not inferior to those of Brighton and the Crystal Palace.

Edinburgh, March 26

RALPH RICHARDSON

Acherontia Atropos

CAN any of your readers throw any light on the *raison d'être* of the dimorphism of the larva of the Death's-head Moth (*Acherontia atropos*)? Some years ago I found five larvae of this insect on a bush of jasmine. They were all probably offspring of one female. Two of them were of the dark chocolate-coloured variety so strikingly dissimilar to the normal or commoner type. The *imago* of one of the dark-coloured larvae differed in no respect that I could perceive from the ordinary form. It has occurred to me that the dark variety may be due to its simulating the dead, withered, blighted, or diseased shoots of the potato, as its commoner brother does the healthy leaves and stalks.

Taunton

FRED. P. JOHNSON



## Destruction of Flowers by Birds

As a sequel to the discussion in the columns of NATURE (vol. ix. pp. 482 and 509) on the destruction of flowers produced by small birds nipping off the bottom of the perianth, I may record that their education in this habit is progressing here.

My own crocuses, in a town garden, have suffered for years, each one being nipped off as soon as it expanded, but the country gardens have hitherto escaped; this year, however, I noticed that a garden five miles from the town and close to a large farm-yard was attacked, and no single flower left uninjured.

Burton-on-Trent, March 30 P. B. M.

## OUR ASTRONOMICAL COLUMN

SOUTHERN DOUBLE STARS.—(1)  $\gamma$  Coronæ Australis.—This fine binary must have very much changed its angle of position since the last published measures, if, as is most probable, the late Capt. Jacob's elements afford an approximation to the true orbit. They are as follows:—Periastron passage, 1863'08; period, 100'8 years; node,  $352^{\circ} 13'$ ; distance of periastron from node,  $266^{\circ} 25'$  (or its angle of position,  $256^{\circ} 12'$ ); inclination,  $53^{\circ} 35'$ ; eccentricity, 0'602, and semi-axis,  $2^{\circ} 549$ . Calculating from these elements, we find the subjoined angles and distances about the present epoch:—

	$^{\circ}$	$'$	$''$
1874'5	155'7		1'98
75'5	153'0		2'04
76'5	150'4		2'09

The last measures recorded by Capt. Jacob gave for 1858'20, angle,  $343^{\circ} 0$ ; distance,  $1^{\circ} 53$ . Though  $\gamma$  Coronæ Australis is accessible at the observatories of Southern Europe, our information respecting it comes so far, we believe, from India or the other hemisphere.

Amongst the southern binaries, certain or suspected, to which we would also draw attention with the hope of seeing measures put upon record during the present year are  $h$  4087, which, as measured by Jacob, showed considerable change since Sir John Herschel's Cape observations;  $\gamma$  Centauri, a difficult object in 1853, but comparatively easy at the end of 1857, though the angles so far are very puzzling;  $h$  5014, with the view to decide as to its binary character or otherwise; and  $h$  5114, which is in all probability a revolving double-star of short period; it is B. A. C. 6632: if this star is regularly measured, an orbit may soon be feasible. To save trouble of reference, we append the places of these stars for the commencement of 1875:—

	R.A.	N.P.D.
	h. m. s.	$^{\circ}$ ' "
$h$ 4087 ...	8 17 43	130 35'5"
$\gamma$ Centauri ...	12 34 38	138 16'4"
$h$ 5014 ...	17 58 38	133 24'2"
$\gamma$ Coronæ Aust. ...	18 57 48	127 14'3"
$h$ 5114 ...	19 17 46	144 34'4"

VARIABLE STARS.—In *Astron. Nach.* No. 2031, Herr Julius Schmidt, of the Observatory at Athens, publishes results of his observations of this class of objects in 1874. He has many maxima and minima of the three shorter-period variables in Sagittarius discovered by him in 1866; the positions for 1875'0 and latest assigned periods are as follows:—

	R.A.	N.P.D.	PERIOD.
	h. m. s.	$^{\circ}$ ' "	d. h. m.
X Sagittarii (3 Fl.)	17 39 41	117 46'8"	7 <sup>d</sup> 01185
W " ...	17 57 2	119 35'1"	7 59327
U " ...	18 24 32	109 12'7"	6 74518

There appears to be some confusion in Schmidt's reference to W and X as regards the star which is identical with 3 Sagittarii of Flamsteed. In *Astron. Nach.* No. 1832, where he gives positions for 1870, he calls Flamsteed's star X, and Schönfeld has followed him in his catalogue of 1875, but in the last number of the same periodical Flamsteed's star is called W. With periods

so nearly alike, this difference of nomenclature may prove troublesome. The second of the above stars has also been termed by Schmidt  $\gamma$  Sagittarii. The period of 68  $u$  Herculis, according to this zealous observer, is about forty days; it has been seen as high as the fourth magnitude and as low as the sixth, but the variation appears to be generally within narrower limits: the times of minima are more easily determined than those of maxima. Schmidt fixes the last maximum of the remarkable star  $\chi$  (Bayer) Cygni to 1874, Nov. 8, and thinks this a pretty certain determination. Argelander's last formula in vol. vii. of the Bonn observations, assigns 1874, Sept. 6, or sixty-three days earlier, but the error of this formula in 1870 amounted to ninety-three days, and had progressively reached this figure since the year 1854, when the calculated and observed time of maximum nearly agreed. Schönfeld gives a formula which still shows errors exceeding forty days and in opposite directions in 1842 and 1871. The interval between the last two observed maxima is 399 days, and another may be expected to occur about the middle of December next; the minimum may be looked for early in June.  $\alpha$  Herculis, according to Schmidt, has been more than usually changeable during the past year.  $\beta$  Pegasi continues irregularly variable through not more than a half magnitude in about forty-one days, occasionally remaining a considerable time without perceptible change.

MINOR PLANETS.—Ephemerides of these bodies for 1875, so far as elements were available, were circulated some time since by Prof. Tietjen, of Berlin, in anticipation of the publication of the *Berliner Astronomisches Jahrbuch*, with the preparation of which he is now charged. The brightest of those coming into opposition during the month of April are Thalia on the 1st, of 10th magnitude; Flora on the 7th, of  $9\frac{1}{2}$  mag.; Hecuba on the 16th, of 10 $\frac{1}{2}$  mag.; Lætitia on the 17th, of 9th mag.; Europa on the 18th, of 10 $\frac{1}{2}$  mag.; and Urania on the 25th, of the same. The only minor planets since No. 7 which rise higher than the 9th magnitude during the remainder of the present year are Metis, Fortuna, and Eurydice in September, Clotho in November, and Massalia in December.

## DANIEL HANBURY, F.R.S.

THE memorable list of those who during the past winter have departed from the scientific world, received last week another name for whose loss there is no palliation to be drawn from the consideration of advanced age or of completed work. Daniel Hanbury died on March the 24th, of typhoid fever, aged 49. Hardly any figure was more familiar than his to those who frequented the meetings of the Royal or Linnean Societies at Burlington House. The same simplicity and quiet enthusiasm which will make his death a matter of sincere regret to those who were accustomed to meet him there, influenced and animated his scientific work. A member of a business house which has almost a historic character, he began, a quarter of a century ago, investigating and writing upon subjects suggested by his occupations. Anyone who has had occasion to follow him in such matters will need no defence of the utility of his work; nor can indeed anyone dispute the value of critical and accurate knowledge about the materials of pharmacy. There was no side, whether literary or scientific, from which he left the subjects of his studies unapproached. A few years since he retired from business in order to obtain greater leisure, and he successfully brought what proved to be the work of his life to a close by the publication, at the end of last year, in conjunction with Prof. Flückiger, of the "Pharmacographia." This was reviewed in these pages at the time of its appearance.\* It is only

\* NATURE, vol. xi. p. 60.

necessary to say now that it is a patient and elaborate investigation from original sources of the usually obscure history and origin of vegetable drugs. Those who best know how to appreciate the book find their admiration everywhere divided between its laboriousness and its perfect conscientiousness.

A life so spent leaves little else to record. He accompanied Dr. Hecker in a tour in Syria; in 1867 he was elected a Fellow of the Royal Society, and was a member of the Council at the time of his death. Of the Linnean Society he was vice-president and treasurer, and his place in it will not be easy to fill. The Society has passed through a somewhat serious crisis for a learned body. The change from the rather old-fashioned retirement of its rooms in Soho Square, and afterwards in the main building of Burlington House, to its present stately quarters, has produced a certain strain upon a constitution always essentially conservative. That difference of temperament between the members of successive generations which is a constant physiological phenomenon, found in Daniel Hanbury an exception. Perfectly cautious, he was perfectly free from prepossession, and no proposition—however revolutionary—seemed to him unreasonable if he could convince himself that it would add to the welfare of the body which he wished to see take the lead as the chief Biological Society of the country.

TWENTY-THREE HOURS IN THE AIR

THE longest aerial trip on record was made by the "Zenith," a balloon which ascended from Paris on Thursday, 23rd March, at half-past six in the afternoon, and landed at Montplaisir, near Arcachon, 700 miles from Paris, on the following evening at half-past five. The aeronaut was M. Sivel, and the passengers MM. Gaston Tissandier, the editor of *La Nature*, M. Albert Tissandier, his brother, an artist, and two other gentlemen.

The balloon drifted southwards from La Villette gas-works for a few miles, when, crossing Paris, it deviated in a westerly direction before reaching the fortifications. It then travelled south-west during the whole of the night, crossing Meudon, Chevreuse, Tours, Saintes, &c., up to the mouth of the Gironde, which was crossed at ten o'clock in the morning, 600 miles having been run in 15½ hours. The wind, which was not strong, having gradually diminished, the crossing of the Gironde occupied not less than thirty-five minutes. As the sun became bright and the weather hot, a brisk wind blew from the sea towards the land, but only up to an altitude of 900 feet. The aeronauts took advantage of this current to escape the upper current drifting towards the sea, and followed the margin of the Gulf of Gascony by alternate deviations obtained by changes of level.

Landing was accomplished without any difficulty by throwing a grapnel, and all the instruments were taken back to Paris. Most interesting observations have been taken, and will be described to the Academy of Sciences at an early sitting. But we are enabled to give a summary of these through the courtesy of our friend M. Tissandier.

A quantity of air was sent by an aspirator through a tube filled with pumice saturated with sulphuric acid in order to stop the carbonic acid and ascertain how many hundreds of grains are contained in each cubic foot. A series of experiments were made at different levels from 2,700 to 5,000 feet, the utmost height reached. The analysis will be made by a new method invented by MM. Tissandier and Hervé Mangon, a member of the French Institute.

The electricity of the air, tested with copper wires 600 feet long, was found *nil*, except at sunrise. It is

known that at that very moment an ascending cold current is almost always felt.

The minimum of temperature was about + 25° Fahr.; at Paris, on the same night, it was about + 28° at the Observatory.

The moon was shining brilliantly, with a few cirrus clouds that manifested their presence by a magnificent lunar halo, which was observed from five o'clock to six in the morning.

The phenomenon gradually developed: the small halo (23°) showed itself first, and afterwards the large halo (46°), but as the aeronauts were at a small distance below the level where icy particles were suspended, the larger halo, instead of being circular, was seen projected elliptically. The dimensions of the smaller halo had been somewhat diminished. The horizontal and the vertical parhelic (or rather paraselenic) circles crossing each other at right angles on the moon, a cross was seen in the middle of a circle, and an ellipse concentric to it. The several phases of the appearance were sketched and will be sent to NATURE. The last part of the phenomenon was a cross, that remained longer than the two halos, which had vanished before the rising of the sun.

W. DE FONVIELLE

ON A PROPELLER IMITATING THE ACTION OF THE FIN OF THE PIPE-FISH\*

THE peculiar mechanism of the dorsal fin of the Pipe-fish (*Syngnathus*) and Sea-horse (*Hippocampus*), Fig. 1, which is also known to be present in the Electric Eel (*Gymnotus*), has been referred to by more than one naturalist. In his "Handbook to the Fish-house in the Gardens of the Zoological Society," Mr. E. W. H. Holdsworth, speaking of the Pipe-fish, remarks that "they generally maintain a nearly erect attitude, supporting themselves in the water by a peculiar undulating move-



FIG. 1.—Side view of Branched Sea-horse (*Hippocampus ramulosus*), in which the dorsal undulating fin is clearly shown.

ment of the dorsal fin;" and the late Dr. Gray, in the Proceedings of the Zoological Society,† also says that "they swim with facility, but not very rapidly, and they seem to move chiefly by the action of the dorsal and pectoral fins. The former is fully expanded when they move, and in very rapid motion, the action being a kind of wave commencing at the front end and continued through its whole length, continually repeated, so as to form a kind of screw propeller."

\* The substance of a lecture delivered by Prof. A. H. Garrod at the Royal Institution, March 16.

† P.Z.S. 1866, p. 238.

That an undulation travelling along a median fin must act as a propeller in a direction the reverse of that in which the wave travels, is evident; because each small section of the fin can be easily recognised to consist, as long as it is in motion, of an inclined plane of which the surface of impact against the water is at all times directed backwards as well as laterally, just in the same way that in sculling from the back of a boat the propelling surface of the oar is always similarly directed.

This undulatory motion of the fin is produced by the lateral movement, in a given constant order, of the spines

which go to compose it; the movement being at right angles to the long axis of the body, and consequently at right angles to the direction in which the fish travels. A delicate membrane intervenes between each two spines, which participates in their changes in position, and forms the inclined planes above spoken of.

Each spine is swollen at its base, where it articulates with the corresponding interneural spine which is embedded in the substance of the animal, and runs sufficiently deeply to become situated between the spinous processes of the two nearest vertebræ. An elongate fusi-



FIG. 2.—Side view of the boat constructed by Messrs. Elliott, with the undulating propeller described in the text.

form muscle runs from each side of the swollen base of the moveable spine, parallel to the spinous processes of the adjacent vertebræ, to be fixed at its proximal or deeper end to the body of the vertebræ which is situated just beneath it. By the action of the one or other of the pair of muscles attached to each spine, the latter can be moved to the right or to the left of the body of the fish. A similar couple of muscles acts on each of the elements of the dorsal fin, which is not complicated by any additional machinery to produce the elegant movement observed when it is in action during life; this, therefore, must be

dependent on the peculiarity in the nerve-supply, with which it is not as yet possible to associate any special structural organisation.

It is not difficult to imitate artificially this undulatory fin of the above-mentioned fish. A series of rods hinged near their middle on a single axis will evidently represent at one end any movements given to them at the other. Therefore, if they are made to come in contact at one extremity with the side of a screw which is placed perpendicular to their direction, and at the same time is provided with projecting discs at right angles to its axis, one between

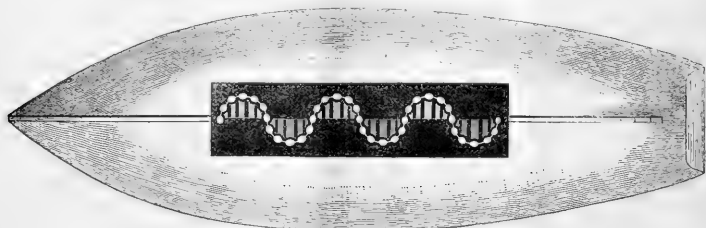

FIG. 3.—The same boat looked at from below, the apices of the rods forming undulating propeller being seen.

every two rods, to keep them in place, the opposite tips will form an undulating curve, just in the same way that the ivory balls in the eccentric apparatus so frequently employed by lecturers on experimental physics, are made to represent the undulations of the atoms of the luminiferous æther in the production of light. Like this apparatus also, if the screw be made to rotate, an undulation will travel along the rods, which is exactly similar to that observed in the fin of the Sea-horse. Such a piece of machinery, driven by clockwork, ought theoretically to propel a boat if properly placed. Mr. C. Becker, of the firm of Messrs. Elliott and Co., has constructed such a boat, which is the property of the Royal Institution (seen sideways in Fig. 2 and from below in Fig. 3.) Its speed is slow, as is that of the fish; in the former case this is accounted for by the fact that the machinery is in this particular

instance perhaps a little too heavy, at the same time that the friction developed in its action is very considerable. In the artificial fin there are just three complete undulations with eight rods in each semi-undulation, forty-eight in all. Between the rods the membranous portion of the fish's fin is represented by oil-silk. The rods and the other portions of the driving gear are so arranged that the former project, with their undulating ends and the oil-silk, in the middle of the boat, along the line of the keel. They form what may be termed a median ventral fin. The undulations are very complete, the curves being true semicircles. In the different species of Sea-horses and Pipe-fish the number of spines in the dorsal fin differ, being twenty or nineteen in *Hippocampus antiquorum*, thirty-seven in a most eccentric looking species described by Dr. Günther, and named by him *Phyllopteryx eques*, and

about forty in the great Pipe-fish (*Syngnathus acus*). In illustration of the amount of force expended in the working of its propeller, it may be mentioned that Prof. Lankester finds that it is only in the above-described muscles, by which it is moved, and in no other part of the body, that the red-colouring haemoglobin is to be detected.

THE NEW STANDARD SIDEREAL CLOCK OF THE ROYAL OBSERVATORY, GREENWICH

THE Royal Observatory at Greenwich has lately acquired a new standard sidereal clock which possesses several peculiarities of construction. The one formerly in use was that made by Hardy, and originally

Fig. 1.

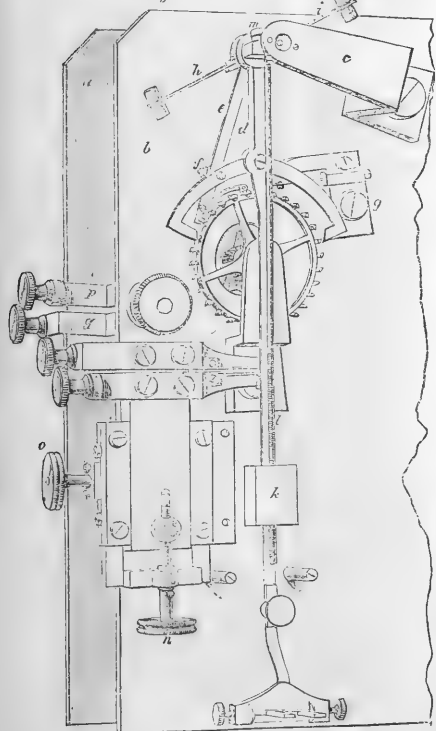

fitted with Hardy's escapement, although this had many years ago been removed and an ordinary dead beat escapement substituted. This clock was a celebrated one in its day, but of late years it seemed scarcely to satisfy modern requirements, and it was decided that a new one should be constructed. This has now been done. The new clock was planned generally by the Astronomer Royal, and constructed entirely by Messrs. E. Dent and Co., of the Strand. It was completed and brought into use in the year 1871, and both as regards quality of workmanship and accuracy of performance it appears to be an excellent specimen of

horological art. As in the galvanic system of registration of transit observations it is unnecessary that the clock should be within hearing or view of the observer, the new clock has been fixed in the Magnetic Basement, in which the temperature varies only a very few degrees during the course of a year.

The pendulum is supported by a large and solid brass casting securely fixed to the wall of the basement, and the clock movement is carried by a platform forming part of the same casting. The Astronomer Royal adopted a form of escapement analogous to the detached chronometer escapement, one that he had himself many years before proposed for use,\* in which the pendulum is free, excepting at the time of unlocking the wheel and receiving the impulse. Several clocks having half-seconds pendulum had since been made with escapement of this kind, but the principle had not before been applied to a large clock. The details of the escapement may be seen in Fig. 1, which gives a general view of a portion of the back plate of the clock movement, supposing the pendulum removed: *a* and *b* are the front and back plates respectively of the clock train; *c* is a cock supporting one end of the crutch axis; *d* is the crutch rod carrying the

Fig. 2.

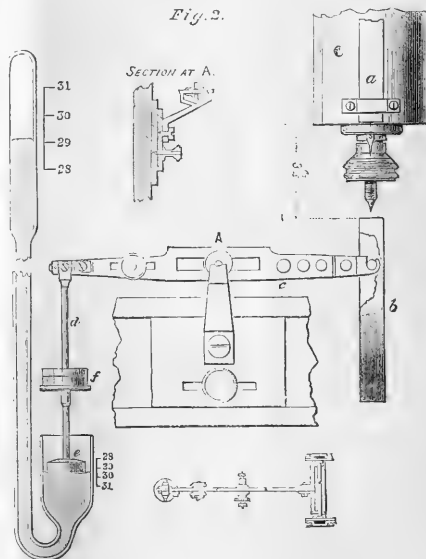

pallets, and *e* an arm carried by the crutch axis and fixed at *f* to the left-hand pallet arm; *g* is a cock supporting a detent projecting towards the left and curved at its extreme end; at a point near the top of the escape wheel this detent carries a pin (jewel) for locking the wheel, and at its extreme end there is a very light "passing spring." The action of the escapement is as follows:—Suppose the pendulum to be swinging from the right hand. It swings quite freely until a pin at the end of the arm *e* lifts the detent; the wheel escapes from the jewel before mentioned, and the tooth next above the left-hand pallet drops on the face of the pallet (the state shown in the figure) and gives impulse to the pendulum; the wheel is immediately locked again by the jewel, and the pen-

\* In the year 1827, in a paper "On the Disturbances of Pendulums and Balances, and on the Theory of Escapements," which appears in the third volume of the *Transactions of the Cambridge Philosophical Society*.

dulum, now detached, passes on to the left; in returning to the right, the light "passing spring" before spoken of allows the pendulum to pass without disturbing the detent; on going again to the left, the pendulum again receives impulse as already described. The right-hand pallet forms no essential part of the escapement, but is simply a safety pallet designed to catch the wheel in case of accident to the locking-stone during the time that the left-hand pallet is beyond the range of the wheel. The escape wheel carrying the seconds hand thus moves once only in each complete or double vibration of the pendulum, or every two seconds.

An ordinary mercurial seconds pendulum was first constructed, with jar of larger diameter than is usually made, but this did not give satisfactory results. Notably it was found, whilst still on trial in the workshop, that when the temperature of the apartment was raised, the clock increased considerably its losing rate, which only slowly returned towards its previous value, showing quick action on the rod and slow action on the quicksilver. This pendulum was finally discarded and another made employing entirely a metallic compensation. A central steel rod is encircled by a zinc tube resting on the rating nut on the steel rod; the zinc tube is in its turn encircled by a steel tube which rests at its upper end on the zinc tube, and carries at its lower end the cylindrical leaden pendulum bob attached at its centre to the steel tube. The weight of the bob is about twenty-six pounds. Slots are cut in the outer steel tube, and holes are made in the intermediate zinc tube, so as better to expose the inner parts of the compound pendulum rod to the action of temperature. For final adjustment of the compensation two straight compensated brass and steel bars ( $b$  and  $f$  in the figure) are carried by a collar, holding by friction on the crutch axis, but capable of being easily turned on the axis. The bars carry small weights at their extremities, as shown. Increase of temperature should accelerate or retard the clock according as the brass or steel lamina is respectively uppermost. The bars were at first placed in the upright (neutral) position, and it is anticipated that, by turning them into an inclined position as respects the pendulum rod, power will be given within a certain limit (reached when the bars stand horizontal) of correcting any defect in the primary compensation, but, on account of the uniform temperature of the Magnetic Basement, no opportunity has yet arisen for testing the efficiency of the apparatus. A contrivance is also added with the object of making very small changes of rate without stopping the pendulum. A weight  $k$  slides freely on the crutch rod, but is tapped to receive the screw cut on the lower portion of the spindle  $l$ , the upper end of which terminates in a nut  $m$  at the crutch axis. By turning this nut the position of the small weight on the crutch rod is altered, and the clock rate correspondingly changed. To make the clock lose, the weight must be raised.\*

In the arrangement of the going power the ratchet is so constructed that it does not touch the great wheel on its flat part, with the object of avoiding unnecessary friction when the maintaining spring alone is acting. The driving weight of the clock is about 5½ lb., and in order to avoid sympathetic vibration, it is made to descend in a compartment of the clock-case separate from that containing the pendulum; it also bears slightly against the side of the compartment.

The brass vertical sliding piece shown at the lower left-hand side in Fig. 1 carries at its upper end two brass bars, each of which has at its right-hand extremity, between the jaws, a slender steel spring for galvanic contact; the lower spring carries a semicircular piece

\* As regards the efficiency of the zinc and steel compensation, it may be here mentioned that the transit clocks made for the Transit of Venus Expeditions were provided with pendulums compensated in this way. Some of these clocks underwent very severe trial at Greenwich before the various expeditions set out, with most satisfactory results. They seemed, indeed, to be superior to clocks fitted with the ordinary mercurial compensation.

projecting downwards, which a pin (jewel) on the crutch rod lifts in passing, bringing the springs in contact at each vibration (these parts are concealed in the figure by the crutch rod); the contact takes place when the pendulum is vertical, and the acting surfaces of the springs are, one platinum, the other gold, an arrangement that has been supposed to be preferable to making both surfaces of platinum. By means of the screws  $n$  and  $o$ , which both act on sliders, the contact-springs can be adjusted in the vertical and horizontal directions respectively. Other contact-springs in connection with the brass bars  $p$   $q$  on the other side of the back plate are ordinarily in contact, but the contact is broken at one second in each minute by an arm on the escape-wheel spindle. The combination of these contacts permits the clock to complete a galvanic circuit at fifty-nine of the seconds in each minute, and omit the sixtieth, for a purpose to be hereafter mentioned.

No contrivance was originally applied to the clock for correction of the barometric inequality, but the clock had not been in use many months before the extreme steadiness of its rate otherwise brought out with marked distinctness the existence of the inequality. It was easily seen that for a decrease of one inch in the barometer reading, the clock increased its daily gaining rate by about three-tenths of a second. The Astronomer Royal eventually arranged a plan for correction of the inequality, founded on the magnetic principle long previously in use at the Royal Observatory for daily adjustment of the mean solar standard clock, and the apparatus has been applied to the clock by Messrs. Dent. Two bar magnets, each about six inches long, are fixed vertically to the bob of the clock pendulum, one in front (shown at  $a$ , Fig. 2), the other at the back. The lower pole of the front magnet is a north pole; the lower pole of the back magnet is a south pole. Below these a horseshoe magnet,  $b$ , having its poles precisely under those of the pendulum magnets, is carried transversely at the end of the lever  $c$ , the extremity of the opposite arm of the lever being attached by the rod  $d$  to the float  $e$  in the lower leg of a syphon barometer. The lever turns on knife edges. A plan of the lever (on a smaller scale) is given, as well as a section through the point  $A$ . Weights can be added at  $f$  to counterpoise the horseshoe magnet. The rise or fall of the principal barometric column correspondingly raises or depresses the horseshoe magnet, and, increasing or decreasing the magnetic action between its poles and those of the pendulum magnets, compensates, by the change of rate produced, for that arising from variation in the pressure of the atmosphere. As the clock gained with low barometer, it was necessary to place the magnets so that there should be attraction between the adjacent ends; that is, that they should be dissimilar poles. One other point may be mentioned in connection with this apparatus. The cistern in which the float rests is made with an area four times as great as that of the upper tube; so that for a change of one inch of barometer reading, the horseshoe magnet is shifted only two-tenths of an inch, whilst the average distance between its poles and those of the pendulum magnets is about 3½ inches: that is to say, the extent of variation of the position of the horseshoe magnet should be a small fraction of the whole distance, because, with this condition, the effect produced on the rate by equal increments of distance is then practically uniform. The action of the apparatus on the Greenwich clock has, as regards correction of the inequality of rate, been quite successful; and further, the extent of the pendulum arc, which was before subject to a slight variation, is now very constant, and amounts (the total arc) to about 2° 33' with scarcely any change.

This account of the clock will scarcely be complete without some brief description of the use made of it. It has been mentioned that the clock completes a galvanic circuit fifty-nine times in each minute, but omits the

sixtieth contact. The currents thus obtained (a small battery only being used on the clock) are used to work a relay from which three independent currents from other batteries are derived. One acts upon the seconds magnet of the chronograph for impress of seconds punctures on the paper on the revolving cylinder. The omission of one second in each minute marks with certainty the commencement of the minute. Observations at all the fundamental instruments are registered on this cylinder, and comparisons of clocks are thus entirely avoided. Another current regulates a half-seconds chronometer on the eye-end of the Great Equatorial. The third current regulates the pendulum of a half-seconds clock in the Great Equatorial Room, drives a tapper to make audible the seconds of the clock, and drives also a galvanic chronometer placed in the Computing Room for use in the daily work of comparing and setting to time the mean solar standard clock. The omission of one current in each minute is unimportant as concerns the regulated chronometer and clock, but not so as regards the chronometer which is driven by the current. To accommodate the chronometer to this state of things, its seconds wheel is cut with fifty-nine teeth only, and its seconds circle on the dial correspondingly divided into fifty-nine equal parts. The resting of the hand during one second, which takes place at a particular division of the dial, consequent on the loss of one current in each minute, is therefore compensated for by this construction of the seconds wheel and engraved dial plate.

#### ARCTIC VEGETATION

A FEW notes on the vegetation of the Arctic regions may not be out of season at the present time. For fuller details we may refer to Dr. Hooker's exhaustive essay on the distribution of Arctic plants, published in the Transactions of the Linnean Society, vol. xxiii., 1862. Since the appearance of this article very little has been added to our knowledge of Arctic vegetation, if we except the flora of Spitzbergen. Several naturalists have since visited the islands of this group, and about thirty additional species of flowering plants have been discovered. The greater part of these additions have been published in the *Journal of Botany*, vol. ii. pp. 130 to 137 and 162 to 176, and vol. i., series 2, p. 152; but a few interesting plants new to the group, collected by the Rev. Mr. Eaton, and now in the Herbarium at Kew, do not appear to have been published. With the exception of the shores of Smith's Sound in North America, Spitzbergen is the most northerly land yet trodden by the foot of restless explorers, and from its relative accessibility its vegetation is perhaps better known than any other part lying far within the Arctic circle. For this reason, and on account of their high latitude, we have chosen the vegetation of the Spitzbergen Islands to illustrate the whole flora of the Arctic regions. We have been influenced in this choice, too, by the fact that many of the species there represented are indigenous in Britain. Most of these species, it should be stated, are confined to the mountains of the north of England and Scotland.

To give a general idea of the whole flora of the North Frigid Zone, we may quote a few of Dr. Hooker's figures. By way of explanation it should be mentioned that Dr. Hooker takes a very broad view of species, and many forms considered as distinct species by some botanists here count as varieties. The more recent additions to the flora of Spitzbergen would not materially alter these figures, because the same species were all, or nearly all, previously known to exist in Arctic Continental Europe or America. A few deductions would also probably have to be made. For instance, the Reed-mace, *Typha*, appears to have been included by mistake in the list of Arctic American plants. The total number of species of flowering plants—which

alone we shall concern ourselves—given, is 762, of which about fifty are exclusively confined to the Arctic regions. A very large proportion of these are found in Scandinavia, south of the Arctic circle, and reappear in the Alps; a few reach the Alpine regions of the mountains of India and Africa, and a few reappear in the extreme south of the southern hemisphere. In a less degree the same thing occurs from north to south on the American continent. Of these 762 species, 616 have been observed in Arctic Europe, 233 in Arctic Asia, 364 in Arctic West America, 379 in Arctic East America, and 207 in Arctic Greenland. From the proportions the respective figures for the five different areas bear to the total, it will be seen that nearly all the areas must have a majority of species in common, and that each area has very few species peculiar to itself. Before proceeding to give a sketch of the flora of Spitzbergen, there is one remarkable fact deserving of special notice. Of the 207 species found in Greenland, 195 are Scandinavian types, and only 12 are American or Asiatic types.

A glance at the map for the position of the Spitzbergen group will enable the reader to realise more fully the interest attached to the investigation of the plants and animals of a small isolated tract of land in so high a latitude—between  $76^{\circ} 33'$  and  $80^{\circ} 50'$ —especially when told that the highest point at which flowering plants have hitherto been seen is about  $82^{\circ}$ , or within  $8^{\circ}$  of the pole, in Smith's Sound. The geological formation of the group is of the earliest. So far as at present known it consists of granite and other crystalline rocks, and in the south traces of the Carboniferous and Permian strata have been discovered. The climate of Spitzbergen is modified to a certain extent, like the whole of Western Europe, by oceanic streams flowing from the hot regions northwards. Nevertheless, it is exceedingly rigorous, as may be imagined from the fact that the sun never rises more than  $37^{\circ}$  above the horizon, and the winter is of ten months' duration. From the observations of Phipps, Parry, Scoresby, and several foreign explorers, the mean temperature of July, the warmest month, has been estimated at about  $37^{\circ}$  Fahr., and the highest point observed by Scoresby was  $51^{\circ}$  on the 20th of July, 1815. The mean temperature of the year is about  $17^{\circ}$  Fahr., and the mean temperature of the three winter months (Dec., Jan., and Feb.) is calculated at about zero of Fahrenheit. Of course the preceding figures must be treated as very rough approximations only.

From the foregoing brief sketch of the climatal and other conditions of Spitzbergen, a very limited number of flowering plants would be expected to thrive, but at least one hundred species have been observed—a comparatively rich flora, when we consider that it is only in the most favourable situations that they can exist at all. Nearly the whole of the vegetation consists of herbaceous perennials, about one-third being grasses, sedges, and rushes. The nearest approach to woody vegetation are the crowberry (*Empetrum nigrum*), two species of willow (*Salix reticulata* and *S. polaris*), and *Andromeda tetragona*, an Ericaceous under-shrub, neither of which rises more than a few inches above the soil. Taking the families in their natural sequence, we have—1. Ranunculaceæ: six species of Ranunculus, and probably seven, a fragment in the Kew Herbarium, collected by the Rev. Mr. Eaton, appearing to be *R. arcticus*. 2. Papaveraceæ: *Papaver nudicaule*, a pretty dwarf yellow-flowered poppy. 3. Cruciferae: about eighteen species, including *Cardamine pratensis*, ten species of *Draba*, and one species of scurvy grass, *Cochlearia fenestrata*, perhaps the only esculent vegetable found in Spitzbergen, which has proved most valuable to the crews of the vessels that have touched there. 4. Caryophyllæ: about a dozen species, including the following British—*Silene acaulis*, *Arenaria ciliata*, *A. peploides*, and *A. rubella*. 5. Rosaceæ: four species of *Potentilla* and

*Dryas octopetala*. 6. Saxifrageæ: *Chryso-splenium alternifolium*, *Saxifraga oppositifolia*, *nivalis*, *cervina*, *cæspitosa*, *hirculus*, *aizoides*, and four other species not found in Britain. 7. Compositæ: four species, including the dandelion. 8. Campanulacææ: *Campanula uvulifera*. 9. Ericacææ: the little shrub mentioned above. 10. Gentianacææ: *Gentiana tenella*, discovered by the Rev. Mr. Eaton in 1872. 11. Boraginacææ: *Mertensia maritima*. 12. Polemoniaceæ: one species of *Polemonium*. 13. Scrophulariaceæ: *Pedicularis hirsuta*. 14. Empetracææ: the *Empetrum* alluded to. 15. Polygonacææ: two British species, *Polygonum viviparum*, and *Oxyria reniformis*; and *Koenigia islandica*, which is of annual duration. 16. Salicacææ: the two species of willow given above. The remaining families—(17) Juncacææ, (18) Cyperacææ, and (19) Gramineæ—make up the rest, the latter being by far the most numerous, and embracing several British genera and species.

In a broad sense, the Arctic vegetation closely resembles the flora of the higher Alps, but there is less brilliancy and variety of colour in the flowers, yellow and white largely predominating. The plants assume a dense tufted habit of growth, and increase mainly by lateral branches, which take root and in their turn produce offsets. It is possible some or all of them ripen seeds in certain favourable seasons, but the almost total absence of annual plants, and the habit of growth of the perennials, seem to indicate that this very seldom happens. An attentive study of the distribution of Arctic flowering plants would lead us to believe that few new species remain to be discovered; and probably in the lower cryptogams also, few absolutely new forms will be found, though doubtless many known species occur that have not yet been collected. Therefore there is some justness in the complaints of geologists because no geologist has been appointed to the Arctic Expedition, whereas a botanist has been appointed. We may reproduce here the substance of an interesting note on the most northerly species of flowering plants known, which was communicated to this journal (vol. viii. p. 487) by Dr. J. D. Hooker. The four following plants, collected by Dr. Bessel in 82° N. lat., probably on the east side of Smith's Sound, represent the extreme northern limits of phanerogamic vegetation so far as at present known: *Draba alpina*, *Cerastium alpinum*, *Taraxacum dens-leonis* var., and *Poa alpina*. With the exception of the first, these are also indigenous in Britain. We have one more observation to make. Although there is what botanists term an Antarctic flora, not a single flowering plant has been found within the Antarctic circle, and only a very limited number of the lower cryptogams.

### NOTES

THE late Sir Charles Lyell has not been forgetful of the interests of science in his will. He gives to the Geological Society of London the die executed by Mr. Leonard Wyon, of a medal to be cast in bronze, to be given annually and called the Lyell Medal, to be regarded as a mark of honorary distinction and as an expression on the part of the governing body of the Society that the medallist (who may be of any country or either sex) has deserved well of the science. He further gives to the said Society the sum of 2,000*l.*, the annual interest arising therefrom to be appropriated and applied in the following manner:—Not less than one-third of the annual interest to accompany the medal, the remaining interest to be given in one or more portions at the discretion of the Council for the encouragement of geology, or of any of the allied sciences by which they shall consider geology to have been most materially advanced, either for travelling expenses or for a memoir or paper published or in progress, and without reference to the sex or nationality of the author or the language in which it may be written. The Council of the Society

are to be the sole judges of the merits of the memoirs or papers for which they may vote the medal and fund from time to time.

LORD LINDSAY, writing from Florence to the Mayor of Wigon, of which place his lordship is representative, states that in order to recover from the severe effect of the Mauritius fever, caught while observing the recent transit, he is obliged to stay in Italy to recruit. He hopes, however, to be able to return to England by the time Parliament resumes its sittings.

PROF. H. E. ARMSTRONG, of the London Institution, well known for his researches in organic chemistry, and Mr. W. N. Hartley, Demonstrator of Chemistry in King's College, are candidates for the Jacksonian Professorship of Experimental Philosophy in the University of Cambridge. It will be interesting to watch what course the Cambridge authorities will take with regard to the appointment to the vacant chair.

MR. E. J. NANSON, B.A., Fellow of Trinity College, Cambridge, Professor of Applied Mathematics at the Royal Indian Engineering College, Cooper's Hill, has been selected by Prof. Adams to succeed the late Prof. W. P. Wilson in the chair of Mathematics at the University of Melbourne. Mr. Nanson was Second Wrangler and Second Smith's Prizeman in 1873.

THE French National Assembly have unanimously voted the funds for the creation of a third Chair of Chemistry in the Faculty of Sciences of Paris. The new chair is to be devoted to Organic Chemistry, which, owing to the arrangements with regard to the other two chairs, has hitherto been somewhat neglected.

A CORRESPONDENT sends us the following query on the subject of Arctic Meteorology with reference to the forthcoming Arctic Expedition:—"I have noted from time to time in the pages of NATURE the various items of information respecting the outfit for the Arctic Expedition, but have failed to ascertain what, if any, preparations are being made for the observation of meteorological phenomena. We know little or nothing about the amount of aqueous deposition in the Arctic regions. Are not the vessels supplied with *rain-gauges*? Surely there will be many opportunities of recording the quantity of rainfall or snow-fall, during several months at different stations, or even the hourly rate of deposition at the time of storms. Anemometers, too, might be employed to register the velocity or pressure of wind."

In reply to Mr. Fisher's query (NATURE, vol. xi. p. 364) as to a satisfactory method of killing *Hoplophora decumana*, a correspondent recommends the following method:—First stupify the insect by dropping it into some benzole, or similar fluid, and then pierce it with a needle that has been dipped into a solution of corrosive sublimate.

AMONG the list of Friday evening lecturers at the Royal Institution noted in last week's NATURE, we should have given the name of Prof. Tyndall, F.R.S., whose subject, however, has not yet been announced.

IN the notice of Mr. Hart's list of the flowering plants and ferns of the Arran Islands, Galway Bay (vol. xi. p. 395), we inadvertently gave *Daboecia polifolia* as one of the West European or Atlantic types characterising this flora. This is a bog plant found in Connemara and Mayo, but it does not occur in the Arran Islands, nor are there suitable localities for it, neither is it included by Mr. Hart.

AT the next congress of French meteorologists, which is to be held at Paris in a few days, M. Leverrier will propose to experiment on a large scale for the purpose of testing the efficacy of smoke in preventing young plants from being damaged by the frosty mornings so common in April.



ON Monday, the 22nd March, the first meeting of the Governors of the London School of Medicine for Women took place on the school premises, No. 30, Henrietta Street, Brunswick Square; Lord Aberdare in the chair. The Dean gave a short history of the school. He stated that during the winter session the same courses of lectures and demonstrations had been given as in the other medical schools of the metropolis, and that the number of women students attending was twenty. It was resolved that the proposed constitution and laws should be referred to a committee for consideration, and that in the meantime the school business should be conducted by the Provisional Council as heretofore. It was then agreed that the next meeting of the governors should take place on the 3rd of May, on which day the prizes will be distributed to those pupils who have been successful in the class examinations.

THE Council of the Social Science Association has fixed October 6th to the 13th for holding the Congress at Brighton this year. It has also authorised an exhibition of sanitary and educational appliances and apparatus to be held at the same time in connection with the meeting.

A LONG and interesting letter, dated Soubat, Feb. 7, appears in Saturday's *Times*, giving some details of Col. Gordon's work in Central Africa. He seems to have been fairly successful in the object of his mission—the reduction of these lawless regions to something like order, and the abolition of the slave traffic. Lieuts. Watson and Chippendale, two young Engineer officers who were at Ragaf, about 1,000 miles above Khartoum, succeeded in making some important observations during the Transit of Venus, which are to be transmitted to the Royal Geographical Society. Lieut. Chippendale, when the letter left, was on his way to Dufé. He was to make his way across the Ashua River to Ibrahimia, and from thence to continue his march with only a few soldiers, striking inland for the Albert Nyanza. He is there to obtain a canoe at any cost, and return, if possible, from the Albert Nyanza down the Nile to Dufé, thus establishing the fact whether the Nile is navigable between these two points.

A TELEGRAM, dated Ulm, March 30, states that the African traveller Karl Mauch, who is at present staying in Blaubeuren, has suffered such severe injuries in consequence of a fall that his life is despaired of.

It is stated that a project has been formed, under the sanction of Capt. Sir John H. Glover, Mr. R. N. Fowler, and other well-known gentlemen, for the formation of a canal from the mouth of the African river Belta, on the Atlantic, in the neighbourhood of Cape Bajador, to the northern bend of the River Niger, at Timbuctoo, a distance of 740 miles.

THE French are trying to open a regular trade with Timbuctoo and Soudan *via* Tusalah, the chief city of Touaregs. They have recently conquered the oasis of Goleah, about 600 miles from the coast. It is from that place that M. Paul Soleillet, the enterprising Sahara explorer, will start for Tusalah, having to march a distance of only 900 miles. The colonisation of Algeria has recently received a strong impulse from more than 10,000 Alsace-Lorrainers having settled in the colony. The European population is increasing not only by a sensible flow of emigration, but by the excess of births over deaths. The colonists, exclusive of the army, now number 250,000, while the native population is not more than 2,250,000. The governor of the three provinces is General Chanzy, who has decided on the institution of three annual fairs to be held in the southern part of each province. Goleah being too far south, a city will be founded for that purpose at about 300 miles from the coast, in the eastern province. It is expected that, attracted by these fairs, Arabs and

Touaregs of the west will resume the old trade. Another French African settlement is the district south of the Gold Coast, known as Gaboon. The Marquis de Compiegne and M. Marche, who explored this region last year, are shortly to resume their explorations, which had been cut short by hostile tribes.

M. LARGEAU, another French explorer, left Algiers a few weeks ago for Rhadamez, an oasis in the central part of the Sahara. A letter dated 17th February last has been received from him. He was very well received by the Sheikh and the Djamaa, or national council of natives. Explanations were given to him as to the murder of his fellow-traveller Dournaux-Duperé, whose conduct had been rather indiscreet. The Djamaa is anxious to open commercial relations with France, and M. Largeau will soon begin his return journey by another way in order to ascertain if it is not more practicable than the one by which he travelled southwards.

FROM the official report of the chamois shooting in the canton of Griions during 1874, it appears that during the year 918 chamois, 4 bears, and 18 eagles (*Aquila fulva*) were killed in the canton. The highest number of chamois killed by one sportsman was 16; the term for shooting is four weeks in September. In 1873 the numbers were 696 chamois and 4 bears; in 1872, when the shooting term extended two weeks longer, the numbers were 766 chamois and 3 bears. The result of last year, therefore, is decidedly favourable, and evidently owing to the reduced term of shooting.

MR. F. NORGATE has recently published, under the title of "Humboldt's Natur-und Reisebilder," a selection of pictures of nature and travel from A. von Humboldt's personal narrative of travel and aspect of nature. It is edited, with a commentary, scientific glossary, and biographical notice of the author, by Dr. C. A. Buchheim. It is intended to afford to readers of German and to students of the language a pleasant variety and a relief from the standard works which as a rule form the staple of German readings in this country. The idea seems to us a happy one, and the selections are well chosen; Dr. Buchheim has well performed his part of biographer and interpreter.

A NEW edition [has just been issued by Messrs. W. Hunt and Co., of the late Rev. A. B. Wharton's "Memoir of the Life and Labours of the Rev. Jeremiah Horrox," which was first published in 1859. From the present edition the translation of Horrox's Treatise on the Transit of 1639 has been omitted.

NEAR Cortil-Noirmont (Belgium) two old tombs have lately been investigated; they had the shape of mounds, and were called "the Roman tombs" by the people. In one of them many human bones were found, rusty iron weapons, and many small bronze coins, unfortunately not well preserved. In the other there were only the remains of one human skeleton, but besides this a highly ornamental glass bottle, several large bronze vases, a lamp of the same material, two silver and two gold coins, and a relief cut into rock crystal and representing a lizard. The coins are of the time of Nerva and Hadrianus.

BRICK TEA is a large article of commerce between China and Thibet. It is described as being made chiefly in the neighbourhood of Ya-tso-w in Szechuen, the tea-plant from which it is made being "a hedgerow tree, fifteen feet high, with a large and coarse leaf." The tea is done up in packets, each containing four bricks and weighing five pounds, and is bought at Tatsien-lu for about 6s. 4d.; it sells at Lhasa for 1l. 4s. to 1l. 8s., and at a much greater sum in the districts which lie off the grand road. From these facts it is apparent that the Darjeeling planters could supply Lhasa with tea at prices to undersell the Chinese article at a very considerable profit, and could make a still larger profit by supplying the country which lies between Lhasa

and the frontier of Sikkim. The better class of teas cost at Lhasa about two rupees per pound, but are seldom imported. It is estimated that the annual supply of tea to Tibet amounts to about six millions of pounds, producing an income of not less than 300,000/.

A NEW source of caoutchouc reaches us from Burmah, a description of which has been given in a pamphlet published in Rangoon. The plant yielding this caoutchouc is the *Chavannesia esculenta*, a creeper belonging to the natural order Apocynaceae, an order which includes the Borneo rubber plant *Urceola elastica*, the African rubber plants *Landolphia* spp., as well as other genera yielding milky juices. The plant, which is common in the Burmese forests, is said to be cultivated by the natives for the sake of its fruit, which has an agreeable acid taste. It comes into season when tamarinds are not procurable, and finds a ready sale at Rangoon, at an anna per bunch of ten fruits. The milk is said to coagulate more readily than that of *Ficus elastica*, and to be purer and better for most purposes for which rubber is used.

UNDER the title of "Contributions to the Fossil Flora of the Western Territories, U.S., Part I. The Cretaceous Flora, by Prof. Lesquereux," Prof. Hayden has published the sixth volume of the series of final reports of the United States Geological Survey of the Territories. The work is in quarto, and embraces 136 pages and 137 plates. Very many new species are figured and described. The work covers all the known species of the Dakota group, and constitutes an important starting-point for similar monographs of other divisions of the fossil plants of America. Prof. Lesquereux considers the surface and stratigraphical distribution of the species. In accordance with Dr. Hayden's views, the author finds the group to be of marine origin, as shown by the occurrence of various species of marine molluscs. Prof. Lesquereux is not prepared to commit himself in regard to the correlation of the flora of the Dakota group with that of subsequent geological epochs and their identity, preferring to wait the gathering and examination of other series. He, however, states that this flora, without affinity with any preceding vegetable types, without relation to the flora of the Lower Tertiary of the United States, and with scarcely any forms referable to species known from coeval formations in Europe, presents, as a whole, a remarkable and, as yet, unexplained case of isolation.

THE cultivation of the tobacco plant in Algeria has been carried out very successfully, the soil and climate of that country being well suited to the growth of the plant. In 1874 no less than 4,850,000 kilogrammes, or over 9,700,000 lbs., were produced and passed through the State warehouses. The value of this crop was 141,224/., or nearly double that of 1873. The experiment—though it is no longer merely an experiment, but a practical industry—has been carried on since 1847, and during the past twenty-seven years about 140,000,000 lbs. weight of tobacco has been produced and sold.

It is stated that the Italian Government, following the course it has already adopted on previous occasions, will gratuitously distribute this year 5,000 plants of the *Eucalyptus globulus*, for cultivation in the Agro Romano, especially in the spot infected by malaria.

THE additions to the Zoological Society's Gardens during the past week include an African Civet Cat (*Viverra civetta*), presented by the Earl of Harrington; an Australian Monitor (*Monitor gouldii*), presented by Dr. Pardoe; three Black-necked Storks (*Xenorhynchus australis*) from Malacca, purchased; a Blue-faced Green Amazon (*Chrysotis bouquetii*) from St. Lucia; two Yellow-fronted Amazons (*Chrysotis ochrocephala*) and a Brown-throated Conure (*Conurus aruginosus*) from S. America, deposited.

### ACCIDENTAL EXPLOSIONS \*

THE term "accident," applied in its strict sense to disasters caused by explosions, would imply that these were due to some circumstance, or combination of circumstances, entirely unforeseen, and that they were consequently unpreventable. An explosion which occurs during the preparation or investigation of a compound the explosive nature of which is as yet unknown may be purely accidental, but if, after the properties of the substance have been thoroughly ascertained and made known, an explosion occurs during its production, by some person who has not properly made himself acquainted with or has neglected in some point or other those conditions essential to its production with safety, the knowledge of which is within his reach, the term "accidental" can certainly not be properly applied to it, although in all probability it would be so designated popularly, and even by those entrusted on behalf of the public with the investigation of its origin and results.

In the present discourse the definition "accidental" is accepted in the loose sense in which it is popularly applied to explosions, with the object of examining into the nature and causes of such explosions, and, if possible, of indicating directions in which there may be hope of successful efforts being made for reducing the frequency of their occurrence.

The phenomena attendant upon an explosion are generally due to the sudden or very rapid expansion of matter, accompanied in most instances by its change of state from solid or liquid to gas or vapour. The most simple classes of explosions are those caused by the sudden yielding to force, exerted from within, of receptacles in which a gas is imprisoned in a highly compressed condition, or a liquid has been raised to a temperature greatly exceeding that at which its molecules have a tendency to fly asunder or to assume the state of vapour or gas. The strength or elasticity of the envelope which confines them suddenly yielding to pressure, the liquid passes with great rapidity into vapour, violently displacing by this sudden expansion the surrounding air and any other obstacles opposed to the expanding molecules.

Similar explosive effects less simple in their origin are brought about by the sudden development of chemical activity in mixtures of gases or vapours, of solids and gases, or of solids only, or in chemical compounds of unstable character, the result in all such instances being the development of intense heat and the sudden or very rapid and great expansion of matter.

Examples of the most simple class of explosions are the sudden failure in strength at some particular point, or generally, of the material composing a vessel in which a gas has either been liquefied or highly compressed. Accidental explosions of this character take place chiefly, and happily not very frequently, in the laboratory or lecture-room, yet instances occasionally occur of disastrous explosions resulting from such causes in manufacturing operations, or in the practical application of compressed air or other gases. The most recent illustration of a serious accidental explosion of this kind is that which occurred in the Arsenal at Woolwich in January 1874, with the air-chamber of a Whitehead, or Fish-torpedo, when one man lost his life and several were seriously injured. In this instance some part of the soft steel diaphragm closing the chamber in which the motive power of this self-propellant torpedo (air) was imprisoned under a pressure of about 800 lb. on the square inch, suddenly yielded to the efforts of the gas to return to its normal condition.

Other explosions of this class, which are of more than weekly occurrence, and but too frequently result not merely in destruction of property, but in more or less serious loss of life, are due to the bursting of boilers at factories, mines, and collieries, to say nothing of those which occur in buildings, in connection with heating appliances and with kitchen ranges, and bath- or other heating-arrangements. The explosion of a boiler may arise either from an exceptionally rapid development of steam or from an absence, or failure in the proper operation, of appliances for relieving the pressure in a boiler, by permitting the escape of steam and giving warning when the pressure begins to exceed that of safety. But by far the chief causes of boiler explosions are defects in their construction or repair, and the reduction in thickness of the metal in parts by corrosion or oxidation, internally and externally, from long use, and neglect of proper measures for periodically cleaning the boilers.

The accidents due directly to the deposits formed from water in boilers have been very greatly diminished of late years by the

\* Abstract of a lecture delivered at the Royal Institution, March 12, by Prof. F. A. Abel, F.R.S.

application of preparations called boiler-compositions, of which there are many varieties, their general action being to prevent more or less effectually the carbonate and sulphate of calcium and other impurities in water, which are separated by its ebullition and evaporation, from producing hard impenetrable crusts or coatings upon the inner surfaces of the boiler. The judicious employment of a good anti-fouling preparation, and the thorough periodical cleansing of the interior of boilers, go far to guard against that source of danger; though, in adopting measures to diminish the formation of incrustations, care must also be taken to avoid promoting internal corrosion of the boiler by the agents used.

The operations of the Manchester Steam Users Association for the prevention of steam-boiler explosions, founded, mainly through the instrumentality of Sir William Fairbairn, twenty years ago, and of which Sir Joseph Whitworth has also been a warm supporter from its commencement, appear to have gradually succeeded in very importantly reducing the annual number of boiler explosions by introducing among its members a system of periodical independent inspection. The Association will not allow that the term "accidental," or mysterious, is applicable to steam boiler explosions. Mysterious they certainly are not, as they are generally quite traceable to causes which may be obviated, such as inferior material or defective construction, or local injuries, gradually developing and increasing, which would certainly be discovered before they attained dangerous dimensions, by a proper inspection.

The following data with respect to the causes of boiler explosions are taken from a table prepared by Mr. L. Fletcher, chief engineer of the Association:—40 per cent. were due (from Jan. 1861 to June 1870) to malconstruction of the boilers; 29 per cent. to "defective condition" of the boilers; 15 per cent. to the failure of seams of rivets at the bottom of externally fired boilers; 10 per cent. to overheating from shortness of water; and less than 3 per cent. to accumulation of incrustations.

An examination into the particular nature of the services performed by boilers which have exploded shows that a considerable number of explosions have occurred at ironworks, and a very large proportion at collieries, where plain cylindrical externally-fired boilers are much used. Many of the explosions of these particular boilers arise from places which remain for a time concealed in the overlaps of the seams of rivets, defying detection, but gradually extending from one rivet hole to another, till some sudden strain causes them to extend throughout the entire seam, the boiler splitting in two. The particular description of boiler which gave rise to the largest number of fatal accidents during the year taken as illustration was the single-flued or Cornish boiler; and it was stated by Mr. Fletcher that all these explosions must have been the result of glaring neglect, as there is no boiler safer to use when well made and properly cared for. The simple precaution of strengthening or giving internal support to the sides of the furnace-tube of these boilers, the importance of which was demonstrated many years ago by Sir W. Fairbairn, appears to be still greatly neglected, the result being the frequent collapse of the tube through weakness. Very few explosions in 1873 appear to have been due to the neglect of the attendants, but by far the greater number to that of the boiler owners or the makers.

[The lecturer then gave a number of instances strikingly illustrative of the statements above made.]

The foregoing and other very numerous illustrations of the appalling display of ignorance, neglect, or recklessness in dealing with the application of steam power, point strongly to the importance of legislation connected with this subject. There can be no reason why the responsibility of the proper condition of boilers and steam apparatus generally should not be thrown upon inspectors, just as the proper fencing of machinery in factories, and the proper condition of steam boilers in a passenger steamship, are secured by a system of responsible official inspection.

The explosions which are often recorded as occurring in kitchen ranges and in boilers used in connection with the heating of buildings are not unfrequently attended by fatal results. Much of what has been said with regard to boiler explosions generally applies to accidents of this class.

As the water in kitchen boilers is often used for culinary and drinking purposes, the means employed in boilers used for steam purposes only, to prevent the formation of hard deposits, cannot be resorted to; therefore the only means of guarding against accidents to domestic boilers from these causes consists

in frequent and thorough cleaning out, which is especially necessary where the water supply is hard.

Explosions also occur with household boilers of the ordinary circulating class, unprovided with safety valves, through the stop-taps of the pipes which connect them with an overhead cistern being left closed by accident or negligence, in which case steam pressure must speedily accumulate to a dangerous extent, all outlets being closed. Accidents with such boilers are particularly liable to occur during severe frosts in consequence of the circulating pipes becoming plugged up with ice, whereby the outlet for steam pressure is as completely cut off as if the stop-taps were closed. Several accidents due to these two causes, some of them attended by fatal results, were recorded last year. The obvious and simple method of guarding effectually against such explosions is to have the boiler fitted with a reliable safety valve, of the most simple form.

Explosions resulting from the ignition of mixtures of inflammable gas and air constitute even a more formidable class than that just described, for the number of explosions in coal mines which occur in a year is very considerably greater than that of boiler explosions, while the loss of life occasioned by the former is very considerable, and is occasionally appalling in its magnitude.

If marsh-gas, or light carburetted hydrogen, which exists imprisoned in coal-beds and escapes into the atmosphere in the pit-working, either gradually or sometimes under considerable pressure, becomes mixed with the air to such an extent that there are about eighteen volumes of the latter to one of the gas, the mixture burns with a pale blue flame, which will surround that of a candle contained in such an atmosphere; the appearance of such a "corpse light" round the flame of the pitman's candle or lamp-flame is a warning, too generally unheeded, of the presence of fire-damp in quantities likely to be dangerous, for if the proportion of marsh-gas increases much beyond that above specified, an explosive atmosphere will be formed, the violent character of which increases as the proportion of fire-damp approaches that of one volume to ten of air. Marsh-gas requires for its ignition to be brought into contact with a body raised to a white heat; fire-damp, or a mixture of marsh-gas and air is therefore not inflamed by a spark or red-hot wire, but will explode if brought into contact with flame. The fact that this contact must be of some little duration to ensure the ignition of the fire-damp was applied by Stephenson in the construction of his safety-lamp; and a very philosophical application of the property possessed by good conducting bodies, such as copper or iron, of cooling down a flame below the igniting point of the gas, and thus extinguishing it, was made by Davy in the construction of his safety-lamp.

All the efforts of eminent scientific and practical men, for the better part of a century past, to diminish the number of coal-mine explosions by improving the ventilation of the mines and providing the miner with comparatively safe means of illumination, appear to have had very little effect in reducing the number and disastrous nature of these accidents. Since the construction of safety miners' lamps by Davy, Stephenson, and Clenney, repeated and partially successful efforts have been made to reduce the loss of light consequent upon the necessary enclosure of the flame, and thus to lessen the temptation of the miner to employ a naked flame at his work in fiery mines; yet investigations after mine explosions still frequently disclose instances of the employment of candles where they are undoubtedly dangerous, and the regulations which have been made law with the view of preventing accidents through the use of naked lights by miners, where there appears any likelihood of fire-damp escaping and lodging, are in many cases either habitually neglected or very carelessly carried out. One practice which appears to have become very general in mines where fire-damp is known to exist, that of sending Frenchmen with safety-lamps to examine the mines, the men then proceeding to work with naked lights in all places marked as safe by those officials, is obviously a most dangerous one, the lives of many being made absolutely dependent upon the vigilance and trustworthiness of one or two; yet it appears to be one almost forced upon the managers of collieries by the men themselves, who often absolutely refuse to go to work with safety-lamps. Of the three colliery accidents which occurred between Dec. 23 and Jan. 7 last, by which twenty-eight men lost their lives, two afford sad illustrations of the fact that the overlookers and the miners themselves are chiefly to blame for the frequency of these

accidents, and that the practice of employing "firemen" just referred to is a highly perilous one.

There can be no question that the comparatively dim light afforded even by the best constructed lamps in general use is a cause of great temptation to the men to use uncovered lights; it is therefore much to be hoped that continued efforts may be made to apply the electric light to the illumination of mine workings. Some approach to success in this direction was already attained ten years ago, and one cannot but have great faith in the ultimate feasibility of some portable method of illumination by electric agency.

There are, however, causes other than the use of unprotected lights, which contribute to the production of coal-mine explosions. Efficient ventilation of workings, whether in use or not, whereby all dangerous accumulation of fire-damp is avoided, and any sudden eruption of gas may be rapidly dealt with (the gas being largely diluted and swept away as speedily as possible), is indispensable to the safe working of the mine (without any reference to the health of the men) so long as there is any temptation for the use of naked lights. The original laying out of a working greatly affects the question of efficient ventilation, and explosions have been clearly traced to gas accumulations, which there was sufficient power of ventilation to reduce, if the nature of the working had admitted of its proper application. In arranging for the efficient ventilation of a mine, ample provision for rapidly applying extra artificial ventilating power should be made, and, in connection with this, the interesting and useful series of observations should be borne in mind which have been made public in communications to the Royal Society and the Meteorological Society by Messrs. R. H. Scott and W. Galloway.\*

Since the employment of gunpowder as a means of rapidly removing coal, or overlying shale, has come into considerable use, there can be no question that an additional and a very serious source of danger has been imported into the working of collieries. That the explosion of a charge of powder in a blast-hole, or the "firing of a shot," has by no means unfrequently resulted in the production of a fire-damp explosion, has been clearly established by careful inquiry. This has been ascribed to two causes, one of them the direct ignition of the explosive gas-mixture by the flame from the shot, the other the dislodgment of fire-damp from cavities or disused workings by the concussion produced, and its ignition by some naked flame or defective lamp in the neighbourhood. If a shot takes effect properly (*i.e.* if the force is fully expended in breaking the coal or rock at the seat of the charge), there is seldom flame produced, but if the tamping which confines the charge in the blast-hole is simply blown out of the latter like a shot from a gun (which not unfrequently occurs when the rock is very hard or the tamping is not sufficiently firm, or when the charge of powder is excessive), the powder-gas issuing from the blast-hole will produce a flash of fire as obtained with a gun, and if the fire-damp were in the immediate neighbourhood, it would no doubt be ignited thereby. But this combination of conditions is not likely frequently to occur; the second cause above given is therefore more likely to be fruitful of accidents; but the existence of a third cause, to which the majority of explosions connected with blasting in collieries is most probably ascribable, has been very clearly established by the careful inquiries, sound reasoning, and ingenious experiments of Mr. W. Galloway, Inspector of Mines. Mr. Galloway conceived, and has clearly established by experiments in the laboratory and in coal-pits, that the sound-wave established by the firing of a shot (especially by the sharp explosion produced when the tamping is shot out of a hole) will by transmission, even to very considerable distances, have the effect of forcing the flame of a safety-lamp through the meshes of the gauze, and will thus lead to the ignition of an explosive gas-mixture surrounding the latter.† It may be hoped that the miner may be trained to a knowledge of the danger he incurs by the incautious use of gunpowder, although the persistent recklessness with which he sacrifices safety to comfort, in despising the use of the safety-lamp, forbids sanguine expectations in this direction.

Reference has not been made to another very possible source of accidents due to the employment of gunpowder for blasting purposes, namely, carelessness in the keeping and handling of the explosive agent by the men. Personal observation by the lecturer of the reckless manner in which powder is frequently dealt with in mines, leads him to believe that this contributes its quota as a cause of colliery explosions.

The accidents in collieries have their parallel in domestic life, in coal-gas explosions, which, though at first sight of comparatively small importance if judged by the loss of life and property which they occasion, yet merit serious consideration on account of the great frequency of their occurrence, and the demonstration which they almost always afford of ignorance or culpable carelessness.

The circumstance that the admixture of even minute quantities of coal-gas with air can be at once detected by the unmistakable odour of the gas, should serve as a safeguard against accidents; unfortunately, however, thoughtlessness or want of knowledge frequently causes this very fact to lead to the opposite result. Escapes of gas in comparatively small quantities often occur at the point of union (generally by a ball-and-socket joint) of a hanging burner or chandelier with the gas-pipe, or at the telescope-joint of such gas-fittings; the column of water required in the joints to confine the gas becoming very gradually reduced by evaporation. In such instances an explosive mixture will accumulate in the upper part of the apartment of which windows and doors are closed, while the air in the lower part will continue for a long time free from any dangerous admixture of gas; and instances are continually recorded in the public prints of the deliberate ignition of such explosive mixtures, by persons who, observing the smell of coal-gas upon entering the room, proceed forthwith to search for the point of escape by means of a flame.

It need scarcely be stated that such a test is a perfectly safe one in itself, and that if the acceptance of the warning given by the odour of gas in the lower part of the room were promptly followed by the simple precautionary operation of leaving open for some time all windows and doors, so as to afford ready ingress of fresh air, and thus speedily expel, or very largely dilute, the gas-mixture, the leakage could be looked for with no risk of accident.

Gas explosions, generally of a serious nature, do occasionally occur through no fault of those who are the direct agents in bringing them about, as by a person entering with a light a closed apartment in which there has been a very considerable escape of gas for some time, or a building in which gas has been entering from a leakage in the supply-pipe or the main.

The employment of illuminating agents closely allied to coal-gas, namely, liquid carbon-hydrogen compounds obtained by the distillation of coal or shale, or derived as natural products from coal-bearing strata, gradually extended during the earlier part of the last quarter of a century until they became formidable rivals of mineral and vegetable oils and even of gas itself.

The several varieties of so-called petroleum spirit which are known as naphtha, benzine, benzoline, gasoline, japper's spirit, &c., yield vapour more or less freely on exposure to air at ordinary atmospheric temperatures, and even in some cases below 50° F. Although much the largest proportion of the petroleum spirit employed is probably used in lamps of some form or other, there are other important uses to which it is applied in large quantities, especially in various industries.

The so-called paraffin- or petroleum-lamp explosions, of which in the earlier days of the employment of these illuminating agents there were so many recorded in the newspapers, and of which one still hears occasionally, were, with very few exceptions, not correctly designated as explosions, and when they were so, were not caused by the employment of the volatile oils or petroleum spirit. As these vaporize very freely at the slightly elevated temperature which a reservoir of a lamp soon attains, air is either entirely expelled from the latter by the vapour, or so diluted by it, that the mixture is not explosive. If therefore flame can have access to vapour escaping from any opening in the reservoir near the wick, in a badly-constructed lamp, it will merely burn as it escapes. If a lamp charged with petroleum spirit be carried incautiously, or accidentally jerked so that the liquid is suddenly brought into contact with the warmer portion of the lamp, near the flame, a very rapid volatilisation may thereby be caused, resulting in a considerable outburst of flame.

If a petroleum oil which has been imperfectly refined, and which, therefore, contains some proportion of the very volatile products, or spirit, be employed in a lamp, a slight explosion may be caused by its yielding up a small amount of vapour at the temperature to which the reservoir becomes heated, and thus producing a feebly explosive mixture with the air in the latter, which may become ignited by the flame of the lamp. An explosion thus produced is not at all of violent character, being generally merely a feeble puff; it may, however, cause the cracking of the reservoir, and the consequent spilling and in-

\* NATURE, vol. v. p. 504; vol. x. p. 157. † NATURE, vol. x. p. 224.

flaming of the oil, and may at any rate lead to accident as already described, by the alarm which it occasions to nervous or ignorant persons.

(To be continued.)

## SOCIETIES AND ACADEMIES

LONDON

Royal Society, March 18.—“On the Behaviour of the Hearts of Molluscs under the influence of Electric Currents.” By Michael Foster, M.D., F.R.S., and A. G. Dew-Smith, B.A. The observations were made chiefly on the heart of the common snail.

An interrupted current, applied directly to the ventricle (or auricle), and of such a strength as not to cause tetanic contractions, produces, as has already been pointed out, distinct inhibition, altogether similar to that brought about in the vertebrate heart by stimulation of the pneumogastric nerve.

Single induction-shocks, of a strength insufficient to cause a contraction, produce no appreciable effect, in whatever phase of the cardiac cycle they are thrown in; but two or more such shocks, the one following the other at a sufficiently short interval, produce a slight inhibition; that is, the succeeding diastole is prolonged.

When a constant current of sufficient intensity is thrown into the ventricle at rest, a contraction or “beat” is observed at both the making and the breaking of the circuit. But the initial, making, beat starts from, and is confined to the region of, the kathode, while the final, breaking, beat starts from and is confined to the region of the anode. This is the case whatever be the position of the electrodes.

A constant current of sufficient intensity to bring about a making and a breaking beat when applied for, say five seconds, may be applied momentarily without producing any beat at all. The constant current, therefore, requires some considerable time to develop its maximum effect.

When a constant current is applied to a spontaneously beating ventricle, a polarisation of the ventricle results of such a kind that the authors would wish at present not to define more strictly than by saying that it is “favourable to the production of a rhythmic beat,” while the region of the anode is thrown into an opposite condition, unfavourable to the production of a rhythmic beat.

On the withdrawal of the current a rebound takes place at either electrode, the kathode region becoming for a time unfavourable to the production of beats, the anode favourable.

Of these two conditions, the one unfavourable to the production of beats, whether it be in the anodic region during the passage of the current, or in the cathodic region during the rebound, is more easily produced by slight currents than its opposite. Hence the total effect of a slight current, the balance of the opposing agencies, is unfavourable to the production of the rhythmic beat.

Consequently, when a current, as in a single induction-shock, is applied for so short a time that its maximum effect is not reached and no direct cathodic contraction or beat is called forth, the net result is a hindrance to the rhythmic beat, or, in other words, an inhibition, which may be too slight to be recognised with a single shock, but becomes evident when the shock is repeated after a not too long interval, and is very marked when several shocks rapidly follow each other as in the ordinary interrupted current.

The main results obtained with the snail’s heart were corroborated by observations on the hearts of *Sepia* and *Aplysia*.

In conclusion, the authors regarding the rhythmic beat of the snail’s heart (which they believe contains no differential nervous structures) as a purely protoplasmic movement, call attention to what may be called the principle of physiological continuity, and offer suggestions towards defining the exact function of the intrinsic ganglia of the vertebrate heart, and of other spontaneously beating organs.

“On the Liquefaction, Fusibility, and Density of certain Alloys of Silver and Copper.” By W. Chandler Roberts, Chemist of the Mint. Communicated by Dr. Percy, F.R.S.

The author states that the most remarkable physical property of silver-copper alloys is a molecular mobility, in virtue of which certain combinations of the constituents of a molten alloy become segregated from the mass, the homogeneous character of which is thereby destroyed. These irregularities of composition have long

been known, and reference is made to them in the works of Lazarus Erckern (1650), and of Jars (1774). A very complete memoir was published in 1852 by Levol, who did much towards ascertaining the nature and defining the limits of this molecular mobility. He discovered the important fact that an alloy containing 71.89 per cent. of silver is uniform in composition. Its chemical formula ( $Ag_2Cu_3$ ) and peculiar structure led him to conclude that all other alloys are mixtures of this, with excess of either metal.

The electric conductivity of these alloys was studied in 1860 by Matthiessen, who doubted the accuracy of Levol’s theory, and viewed them as “mechanical mixtures of allotropic modifications of the two metals in each other.”

The author then describes the experiments he made with a view to determine the melting points of a series of these alloys. He adopted Deville’s determination of the boiling point of zinc ( $1040^{\circ}C.$ ) as the basis of the inquiry, and ascertained by the method of mixtures, the mean specific heat of a mass of wrought iron between  $0^{\circ}C.$  and the melting point of silver, which, as Becquerel showed, is the same as the boiling point of zinc.

The mean of three experiments, which were closely in accordance, gave 0.15693 as the specific heat of the iron; and it should be pointed out that this number includes and neutralises several errors which would affect the accuracy of the subsequent determinations.

Melting points of several alloys were then determined by plunging an iron cylinder into them and transferring the iron to a calorimeter. These melting points varied from  $840^{\circ}C.$  to  $1330^{\circ}C.$ , or through a range of  $490^{\circ}C.$  The alloys which occupy the lowest portion of the curve contain from 60 to 70 per cent. of silver. The results are interesting, as they show that the curves of fusibility and electric conductivity are very similar.

Mr. Roberts then describes experiments in which alloys were cast in red-hot moulds of firebrick, the metal (about 50 oz.) being slowly and uniformly cooled. The results of these experiments on liquefaction are elaborate, and cannot be given in a brief abstract.

The density of pure silver and of Levol’s homogeneous alloy, while in the fluid state, were then determined by the method described by Mr. Robert Mallet,\* the metals being cast in conical vessels of wrought iron. The results obtained were as follows:—

	Pure silver	Levol’s alloy	Density fluid.	Density solid.
	...	...	9.4612	10.57
	...	...	9.0554	9.9045

In the case of silver, the mean linear expansion deduced from this change of density is  $0.0003721$  per  $1^{\circ}C.$ , which is nearly double the coefficient at temperatures below  $100^{\circ}C.$

Physical Society, March 13.—Dr. J. H. Gladstone, F.R.S., president, in the chair.—Mr. W. Chandler Roberts read a paper on the electro-deposition of iron. He referred to the beautiful specimens of electro-iron, the work of M. Eugène Klein, a distinguished Russian engineer and chemist, which were exhibited at the meeting of the British Association at Exeter. In 1870 Mr. Roberts visited St. Petersburg, and had the advantage of receiving from the late M. de Jacobi suggestions which enabled him to deposit iron with much success. He stated that a plate of electro-iron 150 mm. square by 2 mm. thick, was deposited on copper, by Herr Bockluschmann, in 1846. In 1857, M. Feuquières exhibited specimens of electro-iron at the Paris Exhibition. In 1858, M. Garnier patented in England his process, termed *aciérage*, for protecting the surfaces of engraved copper-plates; and in the same year Klein produced the admirable works above referred to. The author then exhibited specimens which he had obtained by Klein’s method. The bath consists of a double sulphate of iron and magnesia, of sp. gr. 1.155; the chief conditions of success being the neutrality of the bath and the employment of a very feeble current. Iron so obtained possesses a higher conductivity than any commercial iron (Matthiessen), its sp. gr. is  $8.139$ , and it occludes thirteen times its volume of hydrogen. A tube of the metal deposited on a rod of wax, which was vacuum-tight at the ordinary temperature, allowed hydrogen to pass freely at a dull red heat.—After a brief discussion, Prof. Guthrie described some experiments which he has recently made, with the assistance of Mr. R. Cowper, in continuation of former researches, on salt solutions and attached water. The main object of these experiments was to ascertain the manner in which mixtures of salts act as cryogens, and to study their combination

\* Proc. Roy. Soc., vol. xxiii. p. 209.

with water at various temperatures and in various proportions. When two salts to which either the acid or the base is common, and which do not form a double salt, are mixed in equivalent proportion, the cryogen produced has nearly the temperature due to the salt, which alone would produce the greatest degree of cold. Solidification begins at a temperature below the melting-point of the least fusible, and continues at lower and lower temperatures until the temperature due to the other constituent salt is reached. Occasionally a cryohydrate having a constant solidifying point has been obtained by mixing in definite proportions salts which are not known to exist in the form of a double salt. In all such cases the solidifying point of the mixture is intermediate between the solidifying points of the constituents, and its temperature as a cryogen is also between the temperatures of the constituents when separately used as cryogens. When two salts composed of different acids and bases are mixed, and no precipitation occurs, it is generally considered that partial double decomposition takes place, two new salts being formed. It was found that if the salts AX and BY be mixed in atomic proportion and dissolved in the smallest possible amount of water, a mixture identical with that produced on mixing AY with BX is obtained. The temperature and composition of the resulting cryohydrate are the same in both cases. But the temperature never falls as low as the point which could be reached by employing whichever of the salts AX, AY, BX, BY, forms a cryohydrate with the lowest temperature. Thus a saturated solution of a mixture of nitrate of potassium and sulphate of sodium solidifies at  $-5^{\circ}\text{C}$ . A mixture of nitrate of sodium and sulphate of potassium also solidifies at this temperature. Since the solidifying point of nitrate of sodium is  $-17^{\circ}$ , this salt cannot exist without partial decomposition taking place in either mixture; for, as has been shown above, its presence would ultimately depress the solidifying point. Dr. Rae remarked that these researches are specially interesting in connection with the salts retained by sea-ice. With a view to study this subject, he has already requested captains of whalers visiting the Arctic regions to bring home samples of ice of different age and from various localities.

## PARIS

Academy of Sciences, March 15.—M. M. Frémy in the chair.—The following papers were read:—On electro-capillary action and the intensity of forces producing it, by M. Becquerel (fourth paper on the subject).—A note by H. Sainte Claire Deville, on the alloys of platinum and iron.—Researches on the fatty acids and their alkaline salts, by M. Berthelot. The subject is treated at length, and the formation of sodium, ammonium, and barium salts, both in solution and in the solid state, is considered.—On acetic anhydride, by the same; account of new experiments to determine the heat evolved during the transformation of acetic anhydride into acetic acid.—A note by M. de Lacaze Duthiers, on the origin of the vessels in the tunica of simple Ascidia.—On the simultaneous formation of several mineral species in the thermal source of Bourbonne-les-Bains (Haute-Marne), specially of galena, anglesite, pyrites, and silicates of the zeolite family (notably of chabasite), by M. Daubrée (second paper).—On a peculiar mode of excretion of gum arabic, by *Acacia Verec* of the Senegal, by M. Ch. Martins.—Report by M. Milne-Edwards, on the measures proposed to prevent the invasion into France of the American insect *Doryphora*, which destroys the potatoes.—M. Mouchez, the chief of the expedition sent to St. Paul to observe the transit of Venus, was then received by the President, who welcomed him in the name of the Academy. M. Mouchez read a long paper on the subject, giving all the details of the transit. He specially described the optical phenomena observed in the vicinity of the contacts, and brings home no less than 489 photographic proofs that can all be utilised for micrometrical measurements. The two interior contacts were observed with great precision, the two outer ones having been rather spoiled by clouds. Altogether this expedition may be considered highly successful.—On the geometrical solution of some new problems relating to the theory of surfaces, and depending upon infinitesimals of the third order, by M. Mannheim (second paper).—On the simplest modes of limit equilibrium which can be present in a body without cohesion and strongly compressed; application to a mass of sand filling the angle between two solid planes and movable round their line of intersection as axis; by M. J. Boussinesq.—A memoir on the formulæ of perturbation, by M. Emile Mathieu.—Micrographic study on the manufacture of paper, by M. Aimé Girard.—On the action of sulphate of ammonia in the culture of beet-root, by M. P. Lagrange.—A note by M. F. Fouqué, on the nodules

of wollastonite, fassaite pyroxene, melanite garnet of the Santorin lava.—On the immediate treatment of intestinal obstruction, by the aspiration of the gases from the intestines, by M. Demarquay.—A memoir, by M. Michal, on the determination of the results of several observations, with special reference to the precision of the result.—A note, by M. L. Berthout, on the discovery of a deposit of fossils in the plain of Ecoûché, in the arrondissement of Argentan (Orne).—A number of members then made various communications on Phyllofera.—The Minister of Public Instruction addressed to the Academy a project of a medal in commemoration of the Transit of Venus.—The Minister of Public Works sent a report of the Commission charged with the proposal of measures to be adopted to prevent the infection of the River Seine in the neighbourhood of Paris.—On certain left perspectives of plane algebraic curves, by M. Halphen.—On some properties of curves traced on surfaces, by M. Ribaucour.—On diffraction and the focal properties of nets, by M. A. Cornu.—On the magnetising function of tempered steel, by M. Bouty.—On the determination of the quantity of magnetism in a magnet, by M. R. Blondlot.—On the theory of storms; a reply to M. Faye, by M. H. Peslin. M. Faye, who was present, then made some observations on the same subject.—On some double stars whose motions are rectilinear, and are due to a difference in proper motion, by M. C. Flammarion.—On the identity of the bromo-derivatives of the hydrate of tetra-bromethylene with those of perbromide of acetylene, by M. E. Bourgoin.—On the quantities of heat evolved in the decomposition of the chlorides of some acids of the fatty series, by M. L. Longuinie, specially referring to butyric, isobutyric, and valeric acids.—On amyloene, or soluble starch, by M. L. Bondonneau.—On a new method of volumetric analysis of liquids, by M. F. Jean.—Chemical researches on the absorption of the ammonia of the atmosphere by the volcanic soil of the solfatara of Puzzola, by M. S. de Luca.—A reply to two recent communications of M. Béchamp, relative to spontaneous alterations of eggs, by M. U. Gayon.—Observation of the life of *Heloderma horridum*, Wiegmann, by M. Sumichrast, reported by M. Bocourt.—On the helminthological fauna of the coasts of Brittany, by M. A. Villot.—Critical observations on the classification of Palæozoic Polyps, by M. G. Dollfus.—MM. Dumay and Martin de Brettes then made some communications relating to the bolide seen on February 10 last.—A note, by M. Neyreneuf, on the combustion of explosive bodies.—A number of scientific works were presented to the Academy by several gentlemen.

## BOOKS AND PAMPHLETS RECEIVED

COLONIAL.—Microscopical Notes regarding the Fungi present in Opium Elight: D. B. Cunningham, M.B., Surgeon H.M. Indian Medical Service (Calcutta).—Geological Survey of Canada; Report of Progress for 1873-74 (Dawson Brothers, Montreal).

## CONTENTS

	PAGE
DEEP-SEA FISHING . . . . .	421
JARDINE'S "PSYCHOLOGY OF COGNITION." By DOUGLAS A. SPALDING . . . . .	422
WHITE'S "SELBORNE" . . . . .	423
OUR BOOK SHELF:—	
Cunningham's "Opium Elight Fungi" . . . . .	424
Kerzhner's "Logarithmic Tables" . . . . .	424
LETTERS TO THE EDITOR:—	
A GYSTAT Problem.—Answer ( <i>With Illustration</i> )—D. M'FARLANE . . . . .	424
The Sounds of the String Organ.—HERMANN SMITH . . . . .	425
The Law of Muscular Exhaustion and Restoration.—G. HENRICHS . . . . .	426
The Height of Waves.—ARTHUR R. GRANVILLE . . . . .	427
Thermometer Scales.—S. G. DENTON . . . . .	427
Accidental Importation of Molluscs and Insects.—Dr. F. BUCHANAN . . . . .	427
WHITE . . . . .	427
Fall of Meteor at Orleans.—HERBERT M'LEOD . . . . .	427
Proposed Aquarium in Edinburgh.—RALPH RICHARDSON . . . . .	427
Acherontia Atropos.—FRED. P. JOHNSON . . . . .	427
Destruction of Flowers by Birds.—P. B. M. . . . .	428
OUR ASTRONOMICAL COLUMN:—	
Southern Double Stars . . . . .	428
Variable Stars . . . . .	428
Minor Planets . . . . .	428
DANIEL HANBURY, F.R.S. . . . .	428
Southern Three Hours in the Air.—By W. DE FONVILLE . . . . .	429
ON A PROPELLER IMITATING THE ACTION OF THE FIN OF THE PIFE-FISH. By Prof. A. H. GARROD ( <i>With Illustrations</i> ) . . . . .	429
THE NEW STANDARD SIDEREAL CLOCK OF THE ROYAL OBSERVATORY, GREENWICH ( <i>With Illustrations</i> ) . . . . .	431
ARCTIC VEGETATION . . . . .	433
NOTES . . . . .	434
ACCIDENTAL EXPLOSIONS. By Prof. F. A. ABEL, F.R.S. . . . .	436
SOCIETIES AND ACADEMIES . . . . .	439
BOOKS AND PAMPHLETS RECEIVED . . . . .	440

ERRATUM.—Vol. xi. p. 403, col. 2, lines 10 and 11 from bottom, for "work" read "rock."

THURSDAY, APRIL 8, 1875

## SMITH'S "ASSYRIAN DISCOVERIES"

*Assyrian Discoveries: an Account of Explorations and Discoveries on the site of Ninevah, during 1873 and 1874.* By George Smith, of the Department of Oriental Antiquities, British Museum. With Illustrations. (London: Sampson Low and Co., 1875.)

JUDGING from the marvellous discoveries made within so short a time in the valley of the Euphrates and Tigris, Assyriology promises to be one of the most extensive as well as the most important auxiliaries to the reconstruction of ancient mythology, history, and philology. It is within the memory of the present generation that M. Botta, the French Consul at Mosul, first began the excavations of the buried cities of Assyria, and we can still remember the enthusiasm and also the incredulity with which Europe received the tidings that this *savant* had actually discovered at Khorsabad, in 1842, the long-lost palaces built by Sargon, about B.C. 722-705, exhibiting one of the most perfect Assyrian buildings and a most excellent specimen of royal architecture. Mr. Layard, who began his excavations as soon as M. Botta carried off his trophies to France (1845), astonished Europe with the still greater discoveries, both at Nineveh and in Babylonia. The researches thus started were continued, especially in Babylonia, by Rawlinson, Rassam, Loftus, and Taylor, and the British Museum now exhibits the remarkable treasures of Assyrian art, science, and literature, which crowned the labours of our explorers.

With the study of these records Mr. George Smith has been engaged for the last ten years; and since 1866 he has periodically published some of the discoveries he made among the fragments of the terra cotta inscriptions deposited in the British Museum. His most startling discovery, however, he communicated in a paper read before the Society of Biblical Archæology, December 3, 1872, which gives the Chaldean account of the Deluge, and which he deciphered on the tablets of the Assyrian library discovered by Layard. In consequence of the great interest excited by these finds, the proprietors of the *Daily Telegraph* placed a thousand guineas at Mr. Smith's disposal, to undertake fresh researches at Nineveh. It was no easy task for him to go over the same ground and reopen trenches in the same localities so successfully worked by his predecessors. Still, the field of research is so extensive, and the hidden palaces are so numerous, that even now far greater treasures may be exhumed than those which have already been reclaimed by the French and English explorers. This will readily be seen from a perusal of Mr. Smith's work which gives the results of his expedition, and from the success he achieved, though his time was limited, and his difficulties were great. In less than four months, excavations on the sites of Kouyunjik and Nimroud, he found over 3,000 inscriptions and fragments of inscriptions, besides many other objects of antiquity. The great object for which Mr. Smith undertook this expedition, namely, to recover, if possible, some of the missing portions of the inscribed terra cotta tablets he had deciphered in the British

Museum, was thoroughly achieved. Among the discoveries he made at Kouyunjik is a veritable fragment containing the greater portion of seventeen lines of inscription which belong to the first column of the Chaldean account of the Deluge, completing the only place where there was a serious lacuna in the story.

The limits of this notice will only permit us to give a very brief summary of the Izdubar legends. Izdubar, the hero of these legends, is a giant who has a court, a seer or astrologer, and officers. Having lost his seer, and being unable to replace him, he determines to seek counsel of Hasisadra, the sage who escaped the deluge. After protracted wanderings through fabulous regions, he at last alights upon Hasisadra and his wife, and inquires of the sage how he became immortal. The sage thereupon tells Izdubar the story of the flood and of the vessel which he built according to the directions of Hea to save himself and his belongings from the universal deluge which the gods brought upon the earth to destroy the human family because of the wickedness of the children of men. This deluge lasted six days, and on the seventh day the storm ceased, when the vessel was stranded for seven days on the mountains of Nizir. At the end of the second hexameron, Hasisadra sent forth some birds to ascertain the state of the ground, the description of which we must give in the language of the legend:—

"On the seventh day in the course of it  
I sent forth a dove and it left. The dove went and turned,  
and  
A resting-place it did not find, and it returned.  
I sent forth a swallow and it left. The swallow went and  
turned, and  
A resting-place it did not find, and it returned.  
I sent forth a raven and it left.  
The raven went, and the corpses on the water it saw, and  
It did eat, it swam, and wandered away, and did not return.  
I sent the animals forth to the four winds, I poured out a  
libation,  
I built an altar on the peak of the mountain,  
By sevens herbs I cut,  
At the bottom of them I placed reeds, pines, and simgar.  
The gods collected at its burning, the gods collected at its  
good burning:  
The gods like flies over the sacrifice gathered."

A careful examination of this legend, which, according to Mr. Smith, is at the latest more than two thousand years before the Christian era, will show the impartial student that he has here the polytheistic prototype of the legend of which the biblical story is a monotheistic redaction. Indeed, Mr. Smith has already announced that he has also discovered the legends of the Creation, the building of the Tower of Babel, &c. A striking illustration of how the Assyrian discoveries will materially contribute to a scientific understanding of ancient mythology may be seen in the legend of "The Descent of Ishtar into Hades."

The goddess Ishtar, *i.e.* Venus, daughter of the Moon, determines to visit "the land from which there is no return." On her arrival at the gate she demands admittance, threatening that if refused she would assault the door and raise the dead to devour the living. After consulting the goddess of the nether regions, the porter admits Ishtar, who, on entering, is, by the command of the Queen of Hades, punished in the same manner as those wives are who have been unfaithful to their husbands. At each of the seven gates of Hades she is stripped of some of her



ornaments and apparel, till at last she is divested of everything. Her detention, however, in the lower regions caused the greatest disorders upon the earth, so much so that her parents, the Sun and Moon, weepingly exclaim, "Since the time that Mother Ishtar descended into Hades the bull has not sought the cow, nor the male of any animal the female." To avoid the threatened extinction of life, Ishtar has her jewels returned and is restored to heaven.

The design of this legend, as read on the broken Assyrian tablets, is not to be made out. In the Talmud, however, where the same legend is recorded in the recast form of the monotheistic crucible, the import of it becomes perfectly clear. After the restoration of the second Temple, we are told that the men of the Great Synagogue, headed by Ezra and Nehemiah, made every effort to wean the people from polytheism and from the orgies practised in connection with the worship of idols. To this end the saints prayed that God might deliver into their hands the demon of sexual lust. In vain did a prophetic voice warn them that if their prayer were granted all nature would at once become stationary, and then life would become extinct. The zeal of the pious would not listen to the utterance, and the demon had to be delivered into their hands. For three days they kept him in prison and in chains, but after the three days no fresh-laid egg could be got in the land, and they had therefore to liberate the demon, depriving him, however, of the power to excite lust in the human breast for the first degrees of consanguinity (*Yoma* 69b; *Sanhedrin* 60a; *Yalkut on Nehemiah*, § 1071). The moral of the Ishtar legend thus becomes apparent, and we see how important the materials are which these Assyrian discoveries yield for the study of comparative mythology.

As to the importance of these cuneiform records to philology, we can only illustrate it by one example. The Hebrew expression עשתי which, when joined with a number denoting ten, makes the combined phrase denote eleven, has caused the greatest difficulty to Semitic scholars from the time when the first Hebrew lexicon was compiled to the present day. Such great authorities as Ibn Ezra (A.D. 1088—1176), and Kimchi (A.D. 1160—1235), take it to denote *thought*, and say that the phrase in question literally denotes "ten which are counted upon the fingers and one in thought," or, as Simonis, who espouses this notion, explains it, "*Cogitationes ultra decem, i.e., numerus cogitatione sive mente concipiendus cum præcedentes numeri ad digitos numerarentur.*" To which Gesenius in his *Lexicon* adds, "This is unsatisfactory enough, though a better solution is still wanting." Now, from the cuneiform we learn that עשתי *istin* is the ordinary expression for *one*, thus yielding the long-wished-for solution of this difficult word.

Amongst the other discoveries which Mr. Smith made and which he classifies under "Foreign Inscriptions," are several Phœnician. The first of these, according to our explorer, is a contract of sale, and probably belongs to the seventh century B.C. "The Phœnician legend is beautifully incised along the edge of the tablet, and is very sharp and clear: Transcribed into Hebrew letters it reads—

דנת אלמלק זי ארלי טמע  
The sale by Almalek of the cultivated field.

The words are divided by dots, and the meaning of the inscription is clear." We, however, question whether "the meaning is clear." It is greatly to be regretted that Mr. Smith did not figure this inscription as he has done in the case of far less interesting subjects. It is important to palæography, inasmuch as it confirms the testimony of the famous Moabite inscription that at the earliest period of Semitic writing the words were not only written separately but were divided by dots, and in this respect essentially differ from the earliest Greek inscriptions. Our reasons for doubting the correctness of Mr. Smith's transliteration are, that (1) we do not remember that דנת signifies *sale*; and (2) the demonstrative pronoun has not in Phœnician the scriptio plena Yod, but is simply י, especially in ancient Phœnician. Nor do we think Mr. Smith's rendering of טמע by *cultivated happy*. The word in question is better translated *undulating*.

We have said enough to show the extreme importance of Mr. Smith's discoveries. Much, however, still remains to be done, and Mr. Smith calculates that no less than 20,000 fragments of this valuable collection of terra cotta inscriptions, portions of which are in the British Museum and at the Louvre, still lie buried at Kouyunjik. It would require 5,000*l.* and three years' work to recover these treasures. Mr. Smith is perfectly willing to undertake the labour of systematic excavations, and we earnestly trust that the nation, either independently of, or through the Government and the Trustees of the British Museum, will be as ready to furnish this comparatively small sum.

#### BANCROFT'S "NATIVE RACES OF THE PACIFIC STATES"

*The Native Races of the Pacific States of North America.*  
By H. H. Bancroft. Vol. I. Wild Tribes. (London: Longmans and Co.)

IT is curious that the comparatively little known Pacific side of North America should have had its ethnology collected and digested, while this task has not been performed for the more familiar Atlantic side. Schoolcraft's great work, principally devoted to the Indians east of the Rocky Mountains, is quite of different character, containing a great amount of original information, but no systematic survey of all that is known. Bancroft's plan, to judge from the present volume, is to compile only, but to compile the substance of the whole existing literature. His success has been remarkable, and his work will be of the greatest service to ethnologists, under one condition. Travellers' accounts of savages are meagre enough already, but abstracts of them shrink almost to the bones. Therefore Mr. Bancroft's book should be used as a skeleton chart to guide inquirers to the original authorities, but should not be treated as making such reference unnecessary.

The physical descriptions of the races of Pacific America, from the Arctic Circle almost to the Equator, are carefully drawn up, though the want of engravings makes it less easy to give precise ideas of them. There are certainly two varieties of man in the district. One is the Eskimo, with their fair complexion, thick-set robust make, and low stature (not, however, so stunted on the Pacific side as in Greenland). The other is the North American Indian, with skin of more or less deep brown, slighter build, and

taller stature. It is possible, however, that on close examination three or four distinct types may be made out, for while some of the Californians are deep brown almost to blackness, the Thinkets are described as being fair as many Europeans, and sometimes with blue eyes. Such differences may partly result from original intermixture of races in the country, but partly also may be due to climate, food, and habits. The following passage, relating to the Indian tribes of New Mexico (p. 477), contains facts of interest in this respect:—"The disparity in physical appearance between some of these nations, which may be attributed for the most part to diet, is curious. While those who subsist on mixed vegetable and animal food present a tall, healthy, and muscular development, hardly excelled by the Caucasian race, those that live on animal food, excepting perhaps the Comanches, are small in stature, wrinkled, shrivelled, and hideously ugly. All the natives of this family, with the exception of the Apaches proper, are tall, well-built, with muscles strongly developed, pleasing features, although at times rather broad faces, high foreheads, large, clear, dark-coloured eyes, possessing generally extraordinary powers of vision, black coarse hair, and, for a wonder, beards. Taken as a whole, they are the most perfect specimens of physical manhood that we have yet encountered. While some, and particularly females, are of a light copper colour; others again approach near to the dark Californian. Women are generally plumper, inclining more to obesity than the men. Some comely girls are spoken of among them, but they grow old early. In contradistinction to all this, the Apaches proper, or Apache nation, as we may call them, are slim, ill-developed, but very agile. Their height is about five feet four to five inches; features described as ugly, repulsive, emotionless, flat, and approaching the Mongol cast, while the head is covered with an unkempt mass of coarse, shocky, rusty black hair, not unlike bristles. The women are not at all behind the men in ugliness, and a pleasing face is a rarity. A feature common to the family is remarkably small feet; in connection with which may be mentioned the peculiarity which obtains on the Lower Colorado, of having the large toe widely separated from the others, which arises probably from wading in marshy bottoms. All the tribes whose principal subsistence is meat; and more particularly those that eat horse and mule flesh, are said to exhale a peculiar scent, something like the animals themselves when heated." Among American tribes of the tropics it would be interesting to ascertain whether there is a real foundation for the accounts of a fair tribe, with light hair and blue eyes, in Costa Rica, the so-called Guatusos, said to be descendants of English mutineers from Sir Francis Drake (p. 748).

It is not less difficult to form an opinion from how many centres the civilisation of these races has originated. Two points suggest themselves to the reader. One is, that the Columbian tribes of the Pacific coast have much in common with the American Indians east of the Rocky Mountains, as the following examples show:—"The Pend d'Oreille, on approaching manhood, was sent by his father to a high mountain and obliged to remain until he dreamed of some animal, bird, or fish, thereafter to be his medicine, whose claw, tooth, or feather was worn as a charm" (p. 283). This is a custom often described among the

Algonquin tribes on the other side of the continent. The same may be said of the games played by the Columbian Indians with bits of wood, which count like dice according to the side turned up, or are passed rapidly from hand to hand, the gamster having to guess which hand (p. 198). These and other matters may have travelled across from the Atlantic tribes. The other point is, that wild tribes, though at a considerable distance from Mexico, have adopted thence some of their customs. The Mexican rubbing-stones for grinding corn (*metlail* and *metlapilli*) are used alike among the tribes of the Isthmus (p. 765) and the Apaches (p. 489). The Mosquito Indians even practise the well-known Mexican custom of drawing blood from their tongues, ears, and other parts of the body, by way of sacrifice (p. 740).

Mr. Bancroft's information is collected from so many and often little-known books, that almost every ethnologist will find in it some new or overlooked facts in his particular department. Col. Lane Fox's "Catalogue of Weapons" contains no mention of a boomerang, or at least a crooked stick thrown boomerang-fashion, among the Pueblo Indians of New Mexico (see p. 541), which is referred to here on the authority of Colyer (Report of Indian Affairs, 1869, p. 91). Possibly, however, it may turn out on further inquiry to be only a common throwing-cudgel, and not properly a boomerang. Again (p. 761), there is a description of a "throwing-stick" used by the Coiba and other Indians of the Isthmus of Panama. "Their javelins are thrown with much force and dexterity by means of a stick slightly grooved to hold the projectile. It is called *estorica*, and is held between the thumb and two fingers, there being a small loop on the side near the centre, in which the forefinger is placed; the dart is cast straight from the shoulder, while the projector is retained in the hand." The occurrence of this weapon here is also not mentioned in Col. Fox's Catalogue, but it affords an interesting geographical link between the nearest districts in North and South America where it has hitherto been noticed, viz., Mexico in the north, and on tributaries of the River Amazons in the south. While on this subject of weapons, another passage may be added as to the tribes of the Isthmus: "They had also javelins with holes pierced in them near the end, so that when cast into the air a loud whistling noise was produced" (p. 774). Unless our memory deceives us, some similar device is known in Central Asia.

Among curious points of savage manners and customs from Mr. Bancroft's summary, the following may be noted. The Chinook Indians in their marriages acted on a principle not unknown among peasants in Russia, who will marry a boy to a woman old enough to be his mother. "It has been noticed that there was often great disparity in the ages of bride and groom, for, say the Chinook, a very young or very aged couple lack either the experience or the activity necessary for fighting the battles of life" (p. 241). Among the Comanche Indians, when a man's wife deserts him, the mode of reparation for his wounded honour is to wipe out the disgrace by killing somebody—anybody whom he may chance to meet (p. 513). We often hear of savages baking pigs in pits dug in the ground to serve as ovens, but the inhabitants of Queretaro may be the only people who thus bake themselves. They

"spend much of their time basking in the sun, and if the sun does not yield sufficient warmth, they scoop out a hole in the ground, burn in it branches and leaves of the maguey, and, when properly heated, lay themselves down in the place, and cover themselves with a mat or the loose earth" (p. 637).

Among the Zapotecs a very interesting art of divination prevailed, and to some extent is still practised. "When a woman was about to be confined, the relatives assembled in the hut, and commenced to draw on the floor figures of different animals, rubbing each one out as soon as it was completed. This operation continued till the moment of birth, and the figure that then remained sketched upon the ground was called the child's *tona*, or second self. When the child grew old enough, he procured the animal that represented him, and took care of it, as it was believed that health and existence were bound up with that of the animals; in fact, that the death of both would occur simultaneously" (p. 661). To conclude the list, among the tribes of North California, the development of the idea of current value, depending partly upon the utility and partly on the scarcity of the objects circulating, is most quaintly illustrated. Their wealth consists in shell-money, called *allicoohick*, white deer-skins, canoes, and, indirectly, in women. The shell which is the regular circulating medium is white, hollow, about a quarter of an inch through, and from one to two inches in length. On its length depends its value. A gentleman, who writes from personal observation, says: "All of the older Indians have tattooed on their arms their standard of value. A piece of shell corresponding in length to one of the marks being worth five dollars 'Boston money,' the scale gradually increases until the highest mark is reached. For five perfect shells corresponding in length to this mark they will readily give one hundred dollars in gold or silver." White deer-skins are rare, and considered very valuable, the possession of one being even said to give a claim to chiefship. A scalp of the red-headed woodpecker is equivalent to about five dollars, and is extensively used as currency on the Klamath. Canoes are valued according to their size and finish. Wives, as they must be bought, are a sign of wealth, and the owner of many is respected accordingly (p. 347).

Our notice of Mr. Bancroft's first volume, consisting as it does merely of condensed accounts of the appearance and habits of wild tribes, is almost necessarily fragmentary. We look forward to the promised speedy publication of the remaining four volumes, of which the next will describe the more civilised nations of Mexico and Central America, the other three containing the comparison and discussion of the native languages, mythology, &c. When the whole work is completed, it may probably lead to the ethnology of American taking a new departure, and passing from its present chaotic condition into a more orderly and scientific state.

#### OUR BOOK SHELF

*Quelques Nombres Caractéristiques relatifs à la Température de Bruxelles.* Note de M. Ern. Quetelet, 6 pp.

THIS small tract briefly summarises the chief points of popular interest in the climate of Brussels relating to the

temperature. The following are the data tabulated which have been calculated from observations made during the forty years 1833-1872:—The mean temperature of the year, seasons, and months; the absolutely highest temperature of each summer, and lowest of each winter; the absolute maxima and minima of each day of the year during any of the forty years; and the mean temperature of every day of the year; together with some other points of interest, such as the degree to which the temperature has risen every summer and fallen every winter. Such tables, if worked out for other places at which the necessary observations have been made, could not fail to prove of great general utility to horticulturists and others, particularly those which show not only the mean temperature of any particular day of the year, but also the degree to which for that day the temperature has been known in the past to rise on the one hand and fall on the other.

Some interesting points appear in connection with the periods of unusually cold and warm weather which are known to occur in North-western Europe at different times of the year. Thus the cold weather of May is not only shown in the forty years' mean temperature of the days, but also in the absolute maximum temperatures which have been noted on the particular days during any of the forty years—the mean of these maxima of the five days from the 6th to the 10th May being  $80^{\circ}\cdot 3$ , but of the five days from the 11th to the 16th only  $77^{\circ}\cdot 6$ .

*A Report of Microscopical and Physiological Researches into the Nature of the Agent or Agents producing Cholera.* (Second Series.) By T. R. Lewis, M.B., and D. D. Cunningham, M.B. (Calcutta: Government Printing Office, 1874.)

MESSRS. Lewis and Cunningham are already well known for their minute and valuable researches on the agencies by means of which diseases are spread. The paper before us, which is one of the Appendices to the "Tenth Annual Report of the Sanitary Commissioner with the Government of India," is divided into three parts. Part I. is concerned with the microscopic examination of the blood, giving the results of such an examination in health, in cholera, and in diseases other than cholera; part II. describes the results of experiments on the introduction of choleraic and other organic fluids into the system; and Part III. gives an account of experiments on the section of the splanchnic and mesenteric nerves. In addition to a discussion of the results of the experiments, the details of the experiments themselves are carefully arranged in a number of tables throughout the work. While the experiments herein described are of high value from a practical medical point of view, they cannot fail to shed some light on the broader scientific question of the origin of Bacteria. From the latter point of view, those parts of the Report bearing on the question of the existence of living organisms in the tissues of healthy subjects after death, and also those portions referring to the effect of heat on morbid products, are of special importance. How do these organisms originate in the glandular and other tissues, and why don't they develop whilst the tissues are in a normal living state? We hope that in a future Report the authors will be able to present some data which will help towards a solution of these questions.

#### LETTERS TO THE EDITOR

[The Editor does not hold himself responsible for opinions expressed by his correspondents. Neither can he undertake to return, or to correspond with the writers of, rejected manuscripts. No notice is taken of anonymous communications.]

#### Ocean Waves

IN reference to the letter in NATURE, vol. xi. p. 386, respecting the "Height of Waves," it may be noted that the data presented would give about 110 ft. for the height above the sea

underneath the observer, and the distance from crest to crest 1,125 ft., and so the one would be one-tenth of the other.

It may be suggested that such measurements would be more reliable if taken from a point above, on the tops or shrouds of the masts of a ship (*vide* Admiralty Manual, p. 94, for directions), so that one could just get a view of the upper horizontal level, so as to see the crests of the other waves advancing.

This computation of wave height much exceeds previous recorded observations by double the amount, so that there may be some error in apprehension, or in statement of the account, or in the calculation.

Dr. Scoresby's observations in the North Atlantic record 24 ft., 30 ft., the highest 43 ft., and the mean 18 ft., in westerly gales; and the frigate *Novara*, 20 to 30 ft. off the Cape Promontory.

French observers in the Bay of Biscay state a height of wave of 36 ft.; Capt. Wilkes, U.S.N., writes of 32 ft. in the Pacific, and Sir J. Ross of 22 ft. in the South Atlantic.

Heights of waves in N.W. gales off the Cape of Good Hope were computed at 40 ft., those off Cape Horn at 32 ft., in the Mediterranean seas at 14 ft. 10 in., and in the German Ocean at 13½ ft., but in British waters they are only found to average 8 to 9 ft.

The velocity of ocean storm waves was observed by Dr. Scoresby in the North Atlantic to be about 32 miles per hour; Capt. Wilkes recorded it at 26½ miles in the Pacific, and French sailors in the Bay of Biscay at 60 miles an hour; and I have noted it myself in the South Indian Ocean at 22½ miles an hour in the great westerly swell after gales.

Further, Dr. Scoresby has estimated the distance between or breadth of his Atlantic storm waves at about 600 ft. from crest to crest, which is only about half of that stated in the letter, and with a proportion of only ⅓ for height to breadth. (*Vide*

Report, British Association, 1850.) Dr. Scoresby states that his waves of 30 ft. in height move at the rate of 32 miles per hour, which hardly accords with the observers of 110 ft. in height, with 25 miles per hour of motion. It would be very desirable that more data should be got on storm waves, for here is another discrepancy of proportion of length to breadth of ⅓ to ⅔, which cannot be surely common or correct.

The accompanying diagram is constructed according to Dr. Scoresby's scale of measurements, 600 ft. breadth, 30 ft. height, and 220 ft. vessel, with rates of wind, wave, and vessel, and from it one may ponder on what small dimensions these terrific looking waves are constructed, and that a ship after all looks only like a cork or chip on the great seas.

The account of the peculiarities of storm seas, also therein mentioned, from the S. W. and N. W. directions in the Atlantic, may be extended to the effects of other winds elsewhere on the ocean surface.

North-east gales in the North Atlantic, and south-east ones in the South Atlantic, appear to have similar effects on the seas and vessels exposed to them.

The waves raised are short, brisk, feathery, and clear, and make a peculiar rushing din, and they do not cause a ship to plunge so much as to roll, and are not accompanied by wet so much as by dry weather.

They are generally not dangerous to navigation in the open sea, as they carry light, clear, swift driving clouds, which do not obstruct marine observations or a view of the horizon all round.

On the other hand, the north-west gales in both hemispheres are attended by heavy, dark, rolling waves of huge bulk, momentum, length, and breadth, up which a ship is driven like up a hill-side, and down which it scuds as into a valley.

Here the vessel plunges more than she rolls, and is subject to

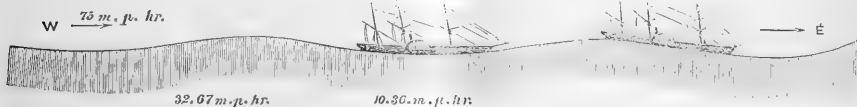

lurches on one side or other, and labours much in consequence of the wetness of the sails and rigging, increasing the weight of the top hamper and its hold by the gales.

These winds are more dangerous to navigation, as they are accompanied by thick heavy clouds lying low in the atmosphere, and shedding much rain and obstructing the view of the horizon all round, and so prevent marine observations by day or by night.

The grand westerly gales of the northern hemisphere, seen on the passage to and from America, occur amongst the latitudes of the counter trades, and are reciprocated by the similar belt in the southern hemisphere below 40° latitude, and are called by Maury the "brave west winds."

This region is traversed by the Australian and New Zealand liners, south of the Cape, and the voyages along this tract are as exciting as a race, and the ship is in much the same predicament as the man in the song with a steam leg.

As much sail as can be safely and possibly carried is spread, as speed is a vital necessity in order to keep the canvas and rigging from being blown away, and to prevent the ship being pooped by a following wave.

The frail bark then boldly scuds along before the wind, down one mountain wave and up another, with cordage creaking and masts bending, as fearless as the wild albatross following in its wake, or the gay porpoise careering in its front.

The difference to the passenger between these two classes of winds seems mainly to depend upon their wetness or dryness, so that the rainy weather adds to the discomfort of the one and the clearer weather in the other gives him some consolation in the storm.

The ship itself would no doubt have a preference, while in the one case its canvas and cordage are soaked with water and its decks deluged or sloppy; in the other its rigging is allowed to retain its natural trim, or even to get slackened by over-dryness, and the decks remain comparatively dry.

As to the waves themselves, it still remains to be explained why they should be greater with winds laden with rain than with dry winds, in the open sea and far away from land, unless the weight of the atmosphere above them should be allowed to count, as the barometer rules higher of course in the north and south easterly winds than in the north or south westerly gales.

Admitting there might be a difference in certain instances, even over the same tract of latitude, of one inch in the height of the mercury in the barometer between westerly and easterly gales, we may find on calculation that this would make a difference of 896,091 tons of weight of the superincumbent atmosphere on the surface of a square mile of the sea. This difference of atmospheric pressure would cause or allow a greater mobility to impression by the winds in the seas outside the tropics and under low barometric indication anywhere, and also a tendency in them to flow in towards these regions, and into storm tracts, as is narrated in accounts of cyclones, where great floods are sometimes produced.

The movements of the ocean swells after gales, it may be hazarded, might be accelerated by the tendency of the disturbed equilibrium to restore itself in the eflux of the seas from the storm region to calmer exteriors.

There might therefore appear to be as much movement and commotion in the waters below as there are in the atmosphere above, in all disturbances of the equilibrium mutually arranged between these two fluid coverings to the surface of the earth.

Edinburgh

J. W. BLACK

Walker's System of Geometrical Conics

It is remarked in NATURE, vol. xi. p. 404, that Walker's "generating" circle appears to have dropped out of recent textbooks; but I may be allowed to add to the statement of your reviewer that Walker's method was revived in the *Messenger of Mathematics*, vol. ii. p. 97. I had been acquainted with his

method for some years previously, and had communicated it to several mathematicians, but omitted it from my elementary "Geometry of Conics" (1872), hoping that I might soon have leisure to develop it more fully in a larger work. Shortly before the publication of my article in the *Messenger*, Mr. R. W. Genese rediscovered the circle and its properties. Mr. Day uses this circle in his work on the Ellipse (1868), but has overlooked one of its characteristic properties. C. TAYLOR  
St. John's College, Cambridge

#### Destruction of Flowers by Birds

"P. B. M.," in NATURE for April 1, refers to the destruction of the crocuses in a garden at Burton-on-Trent, by birds. This may also be observed in the flower-beds in Hyde Park, near Park Lane. It is remarkable, however, that while the yellow flowers are very extensively destroyed, the white ones remain uninjured. The reason for this is not very evident, and I should be glad to see it explained. C. ROBERTS  
Bolton Row, April 6

#### OUR ASTRONOMICAL COLUMN

RED STARS, &c.—We lately referred to the incompleteness of the first catalogue of isolated red stars formed in 1866 by Prof. Schjellerup of Copenhagen. In the last part for 1874 of the *Vierteljahrsschrift der Astronomischen Gesellschaft* is a second and much extended catalogue by the same astronomer. The first list, which was published in *Astron. Nachr.*, No. 1,591, with additions in No. 1,613, contained 293 stars; in the new catalogue the number is upwards of 400. The notes attached have also been considerably extended. The author remarks that his first list was instrumental in the discovery of a number of variable stars, and that Secchi found in it many stars of his Type III. and the whole of Type IV. Those who are interested in the discovery and observation of variable stars will do well to provide themselves with Schjellerup's new catalogue. The same part of the *Vierteljahrsschrift* (which accidental circumstances have delayed in publication) contains an ephemeris of most of the variable stars for the year 1875; also a notice of Prof. Schönfeld's researches on  $\delta$  Cancri from observations to April 1872; the period is found to be 9d. 11h. 37m. 45s., and the epoch of minimum is fixed to 1867, August 31, at 14h. 12m. 15s. Paris mean time. This star has long been known to resemble Algol in its law of variation; the diminution of light commences somewhat suddenly,  $8\frac{1}{2}$  hours before minimum, and about 13 hours after minimum the star recovers the brightness at which it continues to shine for the greater part of its period.

THE COMET OF 1812.—Of those comets discovered during the present century which appear to have periods of revolution approximating to that of Halley's Comet, it is probable that the one detected by Pons at Marseilles on the 20th of July, 1812, will be the first to revisit these parts of space, and this visit may be looked for within a few years' time. We are indebted for our knowledge of the elliptical form of this comet's orbit to Encke, who, working when assistant at the Observatory of Seeberg under the guidance of his "great tutor Gauss," discovered early in the year 1813 that no parabola would represent the observations, and that an ellipse with a period of revolution rather exceeding seventy years was very far preferable. His further and definitive investigation of the elements is found in *Zeitschrift für Astronomie*, ii. p. 377. He made use of observations between July 23 and Sept. 27, taken at Paris, Marseilles, Vienna, Milan, Seeberg, Bremen, Berlin, and Prague, 110 in number, and finally arrived at an elliptical orbit, with a period of 70.69 years, the probable uncertainty of this result allowing of it being as short as 66.54 years, or as long as 75.27 years. Encke does not appear to have had the advantage of the original observations taken at Paris, which appear in the folio volume of observations 1810-20, nor yet of the original observations by Flaugergues at Viviers, which

were not printed until the end of the year 1820, when they found their way into Zach's *Correspondance Astronomique*. Mr. W. E. Plummer, of the University Observatory, Oxford, has reduced the Paris and Viviers observations with every care, and, making use of Leverrier's Solar Tables, has deduced an ellipse quite verifying Encke's computations; he has hopes of being able to assign limits to the period of revolution. We are also informed that the return of this comet's engaging attention at the Observatory of Strassburg, and that under Prof. Winnecke's superintendence sweeping ephemerides will be prepared there to facilitate the rediscovery of the comet. It approaches nearer to the orbit of Venus than to that of any other body in the planetary system, but there could have been no material perturbation from this cause during the last appearance. The comet was detected by Bouvard at Paris on August 1, 1812, and it was also independently discovered on July 31 by Wisniewski (the last observer of the great comet of 1811), at Novo Tcherkask, as stated in a letter from Von Füss to Bode, though he is not credited with this discovery in our cometary catalogues. The other comets which appear to have periods of revolution of similar length are the comet of 1815, usually known as Olbers' Comet, which is the subject of a masterly investigation by Bessel in the Berlin Memoirs, 1812-15; the comet discovered by De Vico at Rome, 1846, February 20, of which the best orbit is by Van Deuse, in his "Inaugural Dissertation," Leyden, 1849; and the comet detected by Brorsen at Altona, 1847, July 20, which has been calculated by D'Arrest and Gould, but may yet admit of further investigation.

#### METEOROLOGY IN ENGLAND

THE address of the President and Report of the Council of the Meteorological Society of England for the present year will be read with a lively interest, awakened and strengthened by a growing conviction that the Society has reached a critical turning point in its history. Hitherto the Society has been regarded as little more than an association of amateur meteorologists,—the national work, falling properly within the province of such a society, of collecting the data of observation for the elucidation of the laws of the weather and climate of England, having been independently carried out by their late energetic, able, and popular secretary, Mr. Glaisher, whose great and in many respects valuable labours in this department are somehow passed over in the documents before us.

The Society, however, has now resolved to undertake the work of collecting meteorological statistics, and in carrying out this resolution has already established ten stations pretty well distributed over different districts of England. It is fitting that on private observers should fall the labour of investigating Climatic Meteorology, leaving the Government to look after the physical side of the science. In making it imperative on all their observers that verified instruments alone be used, consisting of at least a barometer, dry and wet bulb thermometers, maximum and minimum thermometers, and a rain gauge; that the adoption of Stevenson's Thermometer Box be a *sine quâ non*, and that it be not placed within ten feet of any wall; that the rain gauge has its rim placed one foot above the ground; and that the hours of observation be 9 A.M. and 9 P.M.—the Society deserves our hearty commendation.

We must, however, point to a serious omission in the system of observation which has been adopted. No imperative condition is laid down, and no recommendation made, so far as we can see, with reference to the vital question of the height of the thermometers above the ground. If this point be not definitely settled and made an imperative condition of observation, the Society will collect materials on which no scientific inquiry into the climate of England can be based, and on which little, if any, scientific value can be placed. The

point is of paramount importance, especially since temperature observations are not merely the most important popularly, but they form besides the very groundwork of meteorology.

It is a remarkable circumstance that no country in Western Europe could be named, with perhaps the single exception of Ireland, of the meteorology of which so little is known as of England. The meteorological institutes and societies of Scotland, Norway, Denmark, Italy, Austria, Holland, Belgium, &c., have published discussions of atmospheric pressure, temperature, rain, and other of the meteorological elements based on the observations of many years, but we look in vain through the pages of the Journal of the English Society for the discussion of a single one of these elements for England. For any information which is to be had on these matters we must have recourse to the Journal of the Scottish Meteorological Society, in which the barometric and thermometric observations for England have been partly discussed. It is scarcely necessary to say that this essential part of the work of a meteorological society can only be properly performed by its paid officials. Viewed in this connection, it may be worth the consideration of the Council of the Society whether the tendency of the arrangement entered into with the Meteorological Office to supply that office with copies of observations, thus constantly throwing on their officials an enormous amount of mere copying, be not to preclude the Society from properly discharging this part of its work and taking a position among kindred societies which it ought to occupy.

We dissent from the position assumed by Dr. Mann when he states that "the practical outcome of the recent Conference of Meteorologists at Leipsig, of the Meteorological Congress at Vienna, and of the Maritime Conference in London, is an unmistakable and most satisfactory movement on the part of the leading authorities of meteorological science towards concerted and uniform action in the prosecution of their favourite pursuit." We have already stated (vol. x. p. 56) that the Vienna Congress did good work in the treatment of certain details which lie on the outskirts of meteorology, but it would be a mistake to suppose that at these international assemblies of meteorologists any concerted action was taken which would lead to uniformity of observation of atmospheric temperature, pressure, humidity, or rainfall—anything, in short, that would place the observation of these phenomena on an international basis for the subservience of international objects; in truth, the Congress can scarcely be said to have got the length even of attempting any concerted action towards uniformity of observation of these elements which are the very life-blood of the science.

#### DR. BECCARI'S DISCOVERIES IN HERPETOLOGY\*

NOT long ago we called the attention of our readers to the herpetological discoveries of a German naturalist and traveller in New Guinea and the adjoining islands. We are now indebted to the Marchese G. Doria, of Genoa, for an account of the investigations of an Italian explorer, Dr. O. Beccari, in the same countries, although not quite in the same localities. The memoir before us treats of a collection of Reptiles and Batrachians, made by Dr. Beccari in Amboyna, the Aru Islands, and the Ké Islands, in 1872 and 1873, which contained altogether 670 examples referable to fifty-three species. As regards Amboyna, not much novelty could be expected, this island having been thoroughly explored years ago by the Dutch naturalists. But the two other groups of Papuan islands to which Dr. Beccari devoted

his attention were almost *terra incognita* as regards herpetology; Mr. Wallace, their previous explorer, having devoted himself mainly to birds and insects. Here, therefore, Dr. Beccari's collections prove to have contained much interesting material, of which our author gives us an excellent account, illustrated by some carefully executed plates.

The species actually new to science in Dr. Beccari's collection are not numerous, but it is of interest to find that the general character of the reptilian fauna of the Aru and Ké Islands is, like that of their birds, essentially Papuan. In the latter group, however, there is rather a stronger infusion of Indo-Malayan forms. In the Ké Islands the Australian Death-adder, *Acanthobhis antarcticus*, which spreads over the whole of the Papuan region, is very abundant. In Aru the Saurians are more numerous in species than the Ophidians, but in the Ké Islands the contrary is the case. No Batrachian was met with by Dr. Beccari in the latter group of islands, whereas three were found in Wokan, the northernmost of the Aru group, one of which was the widely-spread *Pelodyras ceruleus* of Australia.

This memoir forms part of the sixth volume of the "Annals" of that young and flourishing institution, the Museo Civico of Genoa, of which its author is the originator and director; and, like most of the papers published in the five preceding volumes, contains much matter that is interesting to the naturalist.

#### ARCTIC GEOLOGY

THE following notes on this subject will be of some interest at the present time.

*Greenland.—Glacial Phenomena.*—An examination of the Chart of the North Polar Sea lately issued by the Government,\* shows that Cape Bismarck, the most northern point reached by the German Expedition of 1870, on the east coast of Greenland, is in 77° N. lat., and about 2° south of land seen in 1690. On the west coast, the results of the American Expeditions, 1859–73, prove the continuation of Smith's Sound, through Kennedy Channel, Hall Basin, Robeson Channel, into Lincoln Sea, the broken and indented coasts of which in 84° N. lat. are only 40 degrees north-west of the land seen on the east coast in 1690, giving evidence of a series of islets forming the northern frontier of Greenland; the entire western coast is surrounded by a circlet of bare bleak islets 2,000 feet in height, separated from each other by fjords, through which passes the overflow of the great *mer de glace* which covers the country to an unknown depth, and covers up all sight of the rocks of the inland districts. Here and there this "inlands is" of the Danes reaches the sea, and terminates in a steep cliff, *Sernik Soak* (ice-wall), of the Esquimaux, reaching 3,000 feet in height, where deep glens and fjords penetrate into the country. From the top of these ice-streams Dr. Rink found the surface rising by a series of steps, to the general level of the ice-field, which Dr. Kane describes as the "escaladed structure" of the Greenland Glacier. Once on the ice-field, and leaving the coast, the effect has been described as being similar to that of the land fading away when sailing out to sea—the ice rises gently and almost imperceptibly inland; Prof. Nordenskjöld, who travelled thirty miles inland, found its surface there to be 2,000 feet above the sea. Thus the surface of Greenland beneath the ice must be considerably lower than the islands surrounding it, between which and the ice-wall is the narrow strip of ground on which, and on the islands, the Danish settlements are situated. In summer the snow which covers the great ice-desert melts, and rivers of icy-cold water flow over the surface and fall into the crevasses of unknown depth. These are exceedingly numerous, and apparently increase in number, on penetrating into the

\* "Enumerazione dei Rettili raccolti dal Dott. O. Beccari in Amboyna, alle Isole Aru ed alle Isole Kei durante gli anni 1872-73," per G. Doria. Estratto dagli Ann. del Mus. Civ. di St. Nat. di Genova. Vol. vi. 1874.

\* Chart to accompany Paper and Correspondence relating to the equipment and fitting out of the Arctic Expedition of 1875.

inland district, where not one trace of life, one patch of earth, or one single stone occurs to enliven the monotony of a silent and to the eye motionless ocean, extending for 1,200 miles from north to south, with a breadth of 400 miles. When the additional matter of eight months' snow is poured upon it the glacier overflows, finding a way through the fjords, the overflow corresponding to the effluent glaciers, some of which, like the Humboldt Glacier in Smith's Sound, are sixty miles in width. Where no fjords are available, the ice pours over the cliffs, hanging until gravity overcomes its cohesiveness.

Dr. Rink believes that the outpour of the Greenland precipitation of snow and rain in the form of glacier ice amounts to only two inches, while he estimates the fall at twelve inches; so that, as the evaporation must be exceedingly small, a large portion of the remaining ten inches must be carried off by sub-glacial rivers: Dr. Rink instances a

lake which rises whenever the glacier river disappears. The effect of these streams on the *moraine profonde*, or *couche de boue*, as Agassiz called it, the result of the trituration of the rocks over which the ice passed, must be considerable, and accounts for the muddy water found opposite the entrance of all ice fjords, and the eventual choking up of the channels through which the bergs, broken off from the face of the "lis-blink" (ice-glance) of the Danes, plough their way on their journey seawards, the direction of which is entirely governed by that of the currents, and not invariably, as often imagined, from the north to the south.

Ground-ice has been shown by Dr. Henry Landor to form in Canadian streams, when the thermometer is at zero, being most abundant where there is no surface-ice; as it gradually thickens, it becomes honey-combed in the direction of the current, the water flowing through

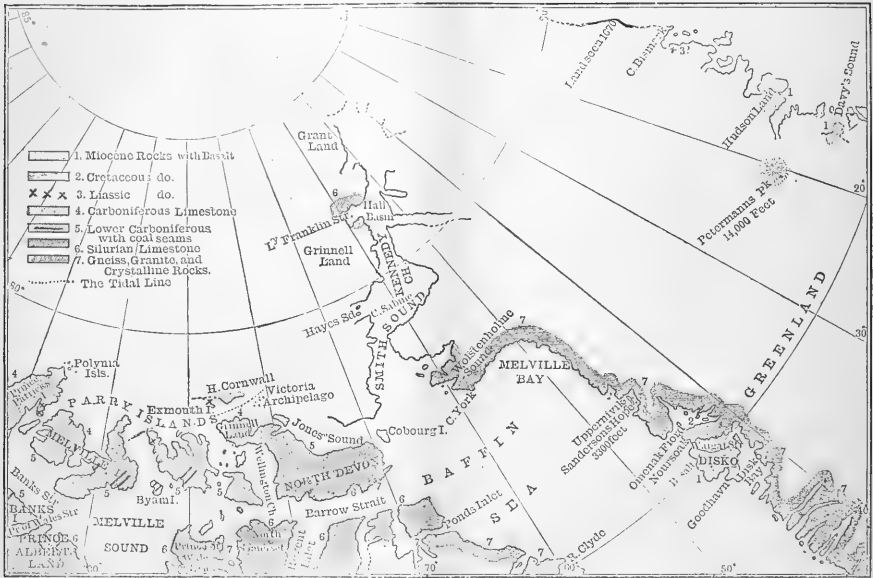

Geological Sketch Map of Arctic Archipelago and Greenland. Compiled by C. E. De Rance, F.G.S. The Topography from the Admiralty N. Polar Chart.

the tubes. In course of time it floats, bearing up the stones to which it is anchored, often of large size, descends the stream, and becomes frozen up in the surface-ice. The movement of these ice-floated boulders often produces grooves on the faces of cliffs, as well-marked, according to Sir W. Logan, as those of glacial times.

Ground-ice laden with sea-weed, stones, and gravel, often rises in the shallow portions of the Baltic, where sheets of boulder-laden ice are driven by storms, and packed on the coast to a height of 50 feet. In Davis Straits the sea-water has a specific gravity, according to Scoresby, of 1.0263, and freezes at 28.3° F., when the salt, 5 1/2 oz. to the gallon, is precipitated, and the "bay-ice" of the whalers is formed, which eventually becomes a floe, and afterwards pack-ice. The ice, in summer, melts on the sides of the channel before that in the centre, which constitutes the middle ice of the whalers; but between the open water and the land a narrow fringe of ice still hangs to the cliff, the "iis-fod" of the Greenland

Danes. This, receiving large quantities of land-slips and other debris from the cliffs, afterwards breaks up and floats seawards, grazing the rocks at low tide, and on melting, deposits the fragments at the bottom of the sea; thus forming a close analogy to those conditions which prevailed when the English boulder-clay was deposited, beneath which the rocks are smoothed and scored, in positions that render it improbable that it was done by glacier ice; the latter prevailed, however, in Britain both before and after the period of submergence. The occasional patches and nests of sand and gravel found in boulder-clay may well have been derived from portions of the gravel-laden ice-foot which became entangled in the pack-ice. Masses of debris-laden ice-foot derived from one district are often driven by winds and high tides on to the coasts of other districts, which well explains the lines of more or less rounded tumulous gravels found in many parts of Britain.

Kane's and Hayes' expeditions found distinct terraces



at various levels from 32 to 110 feet above the high-tide mark of Smith's Sound, and everywhere along the known coast of Greenland. The hollows are described as being filled up with glacier-clay, containing in places Echinodermata, Crustacea, and Mollusca of local Arctic species, with the exception of two, *Glycymeris siliqua* and *Panopæa norvegica*, and extending up to 500 feet above the sea. In the banks overlooking the glaciers, and in nodules of this clay, occur the well-known impressions of the Angmaksætt (*Mallotus arcticus*, O. Fabr.), a fish still living in Davis Straits; of which nodules several examples are preserved in the British Museum, split longitudinally. The great density of the nodules is noticeable, and the analogy to the iron-stone nodules of the coal measures containing plants very striking.

*Recent depression of West Coast of Greenland.*—Arc-tander, between 1777-9, noticed that land in a firch called Igalliko (66° 43') was submerged at spring tides, though buildings with walls five feet in thickness still remained on it; half a century later, the tract was entirely submerged, the ruins being alone visible.

Julianshaab was founded at the mouth of the firch in 1776, near a rock called the "Castle" by the Danes, by which they erected a storehouse, submerged when Dr. Pingel, of Copenhagen, described it in 1835; and he found a village deserted near the glacier which now separates Fredrikshaab from Fiskernaes, on an island now overflowed. The Moravian village of Lichtenfeld, founded in 1758, had to be moved forty years later, and the poles to which the omiaks (women's boats) were tied still remain uncovered at every low tide. Houses of the time of Egede, the Apostle of Greenland, 1721-36, have now the sea flowing into them at high tide.

*Attempt to advance from the coast on the inland ice.*—In 1728 a Danish expedition was sent to endeavour to re-discover the lost (East) Greenland, but failed. In 1751 a Danish merchant, Dalager, advanced inland from about 62° 31', and in two days reached some mountain peaks projecting above the ice, eight miles within the ice-field, but was then obliged to retreat, and returned to Fredrikshaab. In July 1870 Prof. Nordenskjöld and Dr. Berggren advanced from the head of Auleitsvik-fjord over the inland ice thirty miles, to a point 2,200 feet above the level of the sea, in lat. 68° 22' N., passing magnificent rivers, which, flowing between walls of blue ice, eventually disappeared in vertical chasms in the ice, probably 2,000 feet in depth. On the surface of the ice they found a sandy trachytic mineral, scattered like a grey sand, which has been named Kryokonite, and on it, and sometimes on the ice, brown polycellular algæ, the dark masses of which, absorbing the sun's rays, cause the ice to melt, forming the deep holes which traverse the surface.

In Melville Bay, N.W. Greenland, Sutherland describes the glaciers reaching the coast and forming a continuous wall seventy to eighty miles in length, and 1,200 to 1,500 feet in height, of which about one-eighth is above; the Esquimaux required 300 fathoms of line to reach the bottom of the face of the ice, in halibut fishing. In lat. 68°, near Clanshaven, and where valleys come down to the coast, the thickness of the ice is sometimes as much as 2,400 feet. The largest icebergs are launched from Melville Bay. Further north, beyond Cape York, the glaciers are smaller, through greater cold, producing smaller evaporation, while further south the air is charged with watery vapour from the Atlantic.\*

M. Delesse describes shelly deposits on sand beds in the Arctic seas east of Southampton Island and in Fox's Channel, and as far north as 77° near Smith's Sound, at depths of more than 200 metres in some instances, the cold being less intense at this level. In Hudson Straits, Baffin's Bay, and the various straits intersecting Arctic lands, muddy sediment prevails, due to the waste of the paleozoic schists of the North American continent and

the precipitation of sediment being favoured by the impeding effect of the land-locked and ice-locked seas on the agitation of the waters, and to the immense quantities of mud brought into the sea by the glaciers which extend over the Arctic regions.

In Davis Straits, from Cape Farewell to Smith's Sound, the channel, varying in depth from two to 200 fathoms, is stated by Dr. Sutherland to swarm with Echinoderms and brittle Starfish. In Melville Bay, Ascidians, Cirripedes, and seaweed attached to the rocks, do not appear to be often grazed by the bergs, though at times they reap immense crops of Laminaria, with broken shells of *Mya* and *Saxicava*, entangled in their leafy masses, torn from a depth of 100 fathoms. When the bottom is very hard the berg is brought to a stand, and even when consisting of soft mud or clay the same effect is produced by a berg, moraine or talus being pushed up by the movement of the berg. In Davis Straits the bergs are so covered with earthy matter as to resemble rocks, boulders weighing 100 tons often lying on their surface or frozen into their mass. Submarine banks thrown up in this way constantly increase in size by the clustering of small bergs on them, and form the haunt of shoals of cod and halibut, and myriads of sharks. As the ice melts, brown slime, liberated from the ice, is rolled into pellets by the ripple of the water, and is deposited in beds near the coast, resembling the berg-mehl of Sweden.

Prof. A. E. Nordenskjöld, who accompanied the Swedish Expedition to Greenland in May 1870, describes the water off that coast as being a decided greyish brown colour, especially in Davis Strait, off Fiskernaes, and at other times greyish-green. This was found to be due to brown and green slimes of organic origin, which spread over hundreds of thousands of square miles, and afford food for not only Crustacea and Annelides, but to swarms of birds and to the whale; this slime was examined by Dr. Öberg, and found to consist of various species of siliceous Diatomaceæ.\*

*South Greenland.*—Prof. G. C. Laube,† the geologist attached to the second German North Polar Expedition, in his geological map of South Greenland, represents the east coast, as far as 61° N., as chiefly composed of granite and gneiss, which also extends from Cape Farewell to Julianshaab, near which, at the head of Tunnudleorbik, red sandstone and amphibolite occur, between which and the sea there is a large arm of hornblende granite with a belt of zircon granite intervening. Westward is a syenite granite, as far as Nunarsoit.

Dr. Karl Vrba,‡ who examined microscopically more than 200 rocks collected by Laube, of which the exact locality was known, found the following varieties:—Gneiss, granite, curite, syenite, orthoclase porphyry, diorite, diabase, gabbro, and weichstein, including serpentine, &c.

*South-West Greenland.*—In lat. 61° N., Dr. Pingel, the geologist attached to the Danish Expedition of 1828, under Graah, to seek the lost Icelandic colonies, discovered the red sandstone of Igalliko and of the fjord of Tunnudleorbik. No fossils have been discovered, but it is believed to be of Devonian age; the rock is hard and composed of fused quartz particles. This is probably the same bed as that found by the German Expedition a little to the south.

The gneiss, mica schist, hornblende schist, syenite, &c., pierced by granite veins§ of Southern Greenland, continue throughout the whole of the west coast. From it the Greenlanders derive the steatite from which they make their lamps and other utensils. C. E. DE RANCE

(To be continued.)

\* *Geological Magazine*, vol. ix, p. 298. *The Farmer*, Jan. 1, 1868, p. 26.

† Sitzungsberichte der Kaiserlichen Akad. der Wissenschaften, 187

p. 17.

‡ *Op. cit.*, 1874, p. 62.

§ From these narrow veins of granite, rich in felspar, Von Cotta records the presence of orthite and titanite.

\* *Quar. Journ. Geol. Soc.*, vol. ix.

## THE PROGRESS OF THE TELEGRAPH \*

## II.

**E**LECTRIC force pervades all matter. Our planet and the atmosphere surrounding it are vast storehouses of electrical energy in a constant state of unstable equilibrium. Electricity is one of the forces of nature, and may be developed in various ways and under various conditions. The aurora, the thunderstorm, and the earth's magnetism, are each grand displays of electrical force upon a vast scale. Electrical energy may be excited by chemical action, friction, heat, induction, magnetism; and currents of electricity so obtained may be employed for telegraphic purposes. Thermo-electricity, as the name implies, is that generated by electric currents in metallic bodies by the disturbance of the equilibrium of temperature, the essential conditions being, that the extremities of the dissimilar metals should be in opposite states as regards temperature. The discovery of thermo-electric currents is due to Seebeck of Berlin in 1821; the generation of electric currents by the application of heat to a pile or series of dissimilar metals, however, remained in abeyance until the researches of Nobili and

Melloni, who constructed the thermo-electric pile, consisting of alternate parallel bars of bismuth and antimony, placed side by side. Fig. 10 is a representation of the thermo-electric pile as arranged by Melloni. The brass frame on the left contains the compound bars, the wires from the antimony and bismuth poles being connected to a galvanometer, shown on the right-hand side; the quantity of electricity passing from the poles of the pile (regulated according to the difference of temperature of the bars) causes the needle of the galvanometer to be deflected. With thermo-electric currents the quantity of electricity developed depends upon the difference of the temperature of the two poles of the dissimilar metals; the currents may be so delicate that a difference of temperature equivalent to  $\frac{1}{3377}$ th part of a degree may be measured.

Frictional electricity, as the name implies, is that produced by the rubbing together of certain substances. An ordinary form of the frictional electrical machine is shown at Fig. 11. It consists, first, of a hollow glass cylinder supported on brass bearings resting upon glass rods; and then of an exciting rubber of a cushion of leather stuffed with horsehair; this is mounted on glass supports, and the amount of pressure on the cylinder is regulated by screws.

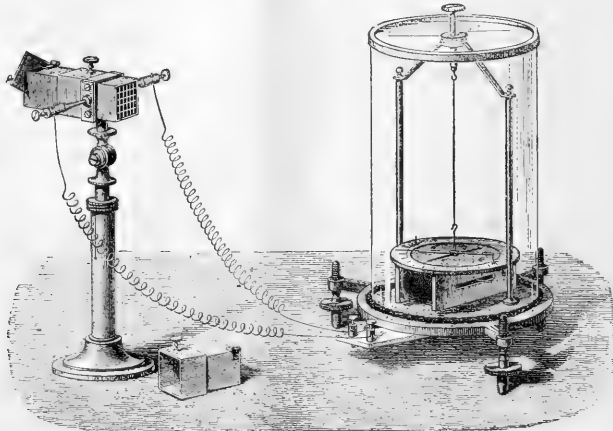

FIG. 10.—Thermo-electric pile, producing electric current by difference of temperature.

A flap of oiled silk is attached to the rubber to prevent the dissipation of the electricity from the surface of the cylinder before it reaches the points of the prime conductor, which draw the electricity from the glass cylinder on the other side. On turning the cylinder the friction of the cushion occasions the evolution of electricity, the production of which is more rapid when the surface of the rubber is smeared with a metal amalgam. When the cylinder machine is arranged for the development of either positive or negative electricity the conductor is placed with its length parallel to the cylinder, and the points project from its side as shown in the figure. The negative conductor supports the rubber and receives from it negative electricity by communication, and not by induction, as is the case with the positive conductor. If it is desired to accumulate positive electricity, a chain must be carried from the negative conductor to the ground; if, on the other hand, negative electricity is required, the conductor must be placed in communication with the earth, and the rubber insulated.

\* Continued from p. 392.

For the purpose of telegraphic transmissions, the current obtained from chemical action, or from a permanent magnet, is generally employed, and will be sufficient for the purposes contemplated in the present summary. The laws and phenomena that come into play during the propagation of an electric current require examination.

Electricity may be thus developed in the form of either a quantity or an intensity current, according to the arrangement of the elements composing the battery. A quantity current is one which, as its name implies, has great surface development. An intensity current is one of series development and of high tension. Quantity and intensity in an electric current may be combined together in different proportions, according to the work required to be performed.

As an example, suppose a battery or pile of twelve elements (Fig. 12), each element consisting of a carbon and zinc plate immersed in a glass jar containing for the exciting fluid a saturated solution of common salt. Now, if the twelve carbon plates of the series are all connected together by a common wire, and the twelve zinc plates are similarly

attached, an arrangement is formed producing a quantity current, the exponent of which will be measured by the superficial area of the individual plates. Thus a current is produced of low tension but great quantity.

If, contrariwise, the zinc and carbon plates of the series are connected together alternately, an intensity current will be produced of high tension. It is thus seen that quantity and intensity may be combined together according to the disposition of the elements composing the battery. For instance, the twelve cells may be arranged

either as a quantity arrangement of six cells each, connected together as two for intensity, or in groups of three for quantity, connected as four in series as an intensity current; or again, as a series of four for quantity, connected together into a group of three for intensity. It is evident, therefore, that some ratio between quantity and intensity must be determined to produce that character of current which shall be best adapted to the work to be performed. The effective force of every electric current depends therefore on two conditions—the electro-motive

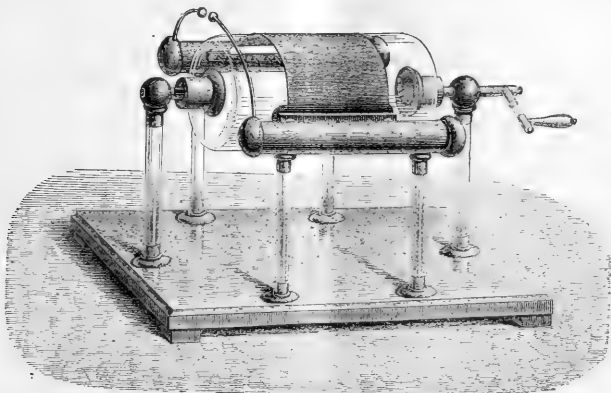

FIG. 11.—Nairne's machine, furnishing the two electricities.

force or tension, and the resistance it has to overcome in passing through the metallic conducting wire. The electro-motive force of a voltaic current varies with the number of the elements and the nature of the metals and liquids which constitute each element, but is in no degree influenced by the dimensions of any of the parts. Submarine telegraphic circuits vary in length, from one mile across the Thames to 2,000 miles in a continuous stretch across the Atlantic, and a current of electric force

effective for the shorter distance would be absolutely useless for the Atlantic circuit.

The chemical power of the voltaic pile was discovered in the year 1800, and water was the first substance decomposed. If water is made a part of the electric circuit, so that a current of electricity passes through it, it is decomposed, and yields up its elements oxygen and hydrogen gases in obedience to certain laws. To decompose acidulated water it may be confined in two glass

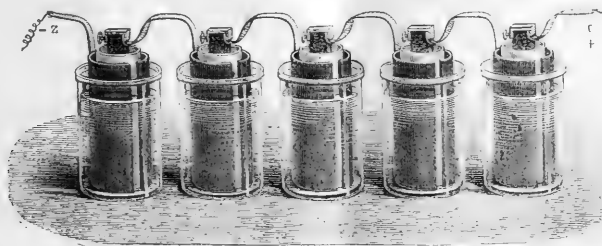

FIG. 12.—Pile formed by five Bunsen's elements.

tubes (Fig. 13), sealed at one extremity, and made part of the electrical circuit by being placed over the two electrodes of the poles of the battery. Gas will then be collected in each tube, but that in connection with the positive pole of the battery will be about half the volume of that in connection with the negative pole, the former being oxygen and the latter hydrogen, as oxygen and hydrogen gases are to each other in water exactly as two to one, by volume.

It has already been stated that all substances, however

well they may conduct electricity, offer some resistance to the passage of the current; thus, the copper conducting wire offers more or less resistance according to its length. If the resistance of a mile of the copper conducting wire is ascertained, each successive mile, if the copper is of equal purity, will have the same measure of resistance; therefore, the resistance of the copper conductor in a cable 2,000 miles long will be 2,000 times the resistance of one mile of the conductor; in other words, the resistance of the wire is in direct proportion to its length.

## ECLIPSE OF THE SUN, APRIL 6

This is a very important fact to bear in mind, as by the measurement of the copper resistance of the conductor in a cable, a basis is at once established by which to determine the distance of a fracture. Knowing the value of the resistance of the whole length of the cable conductor—assume for 2,000 miles the value to be 2,000 units (the measure of the unit being the resistance of one mile of the copper conductor)—an interruption occurs, continuity is broken, and the copper resistance only gives 760 and 1,240 units respectively when measured from either end. Thus is clearly established a basis upon which the approximate distance of the "fault" may be ascertained. Again, it was pointed out that the insulating medium surrounding the conducting wire absorbed an appreciable amount of electricity in the passage of the current through

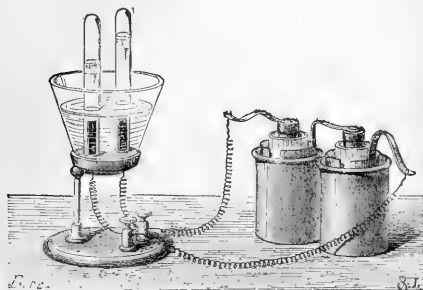

FIG. 13.—Decomposition of water by the chemical action (electro-motive force) of the voltaic battery.

the conducting wire. This absorption may be taken as a constant quantity, and the absorption for any length of cable be determined from given data as regards the time of electrification or the saturation of the circuit, and the time of discharge, or the percentage of leakage from the mechanical imperfections of all the insulating substances. Thus again is established a process by which, under certain conditions of injury to a cable, by correctly measuring the discharge, the position of a fault may with more or less accuracy be localised. The commercial value of a submarine cable depends upon the rapidity of its transmitting capacity, and the speed depends upon the time required to produce a variation in the tension of the current at the distant end sufficient to influence the recording instrument. The working speed depends, therefore, upon the delicacy of the apparatus employed, as then a small difference in the tension will suffice. In cables similarly constructed, but of different length, the speed of each is inversely proportional to the square of the length; because, when the length is doubled, the capacity for charge is doubled, and the electrical waves of charge and discharge have twice the distance to travel; therefore the retardation is increased fourfold. When the dimensions and weight of the insulating medium are fixed, there is a loss of speed if the conducting wire is too small; and again, if the conducting wire is too large, the speed is reduced by the increased capacity of the wire in a greater degree than it is augmented by the reduced resistance of the wire. The best accepted ratio of the insulator to that of the conductor is when the insulator is somewhat less than  $3\frac{1}{2}$  times that of the copper conductor, or, more accurately speaking, in the proportion of 3.41 of insulator to 1 of copper. On long cables and where high speed is required, every current transmitted through the cable should be at equal intervals and of equal duration, so that the charge may be maintained constant between the signals.

(To be continued.)

AS no telegram has been received from Dr. Schuster's party on its arrival at Singapore, we are compelled to estimate the date of its arrival by the telegram in yesterday's papers, which informed us that the *Pera*, in which vessel the Expedition was conveyed from Galle, arrived at Shanghai. The vessel was due there on the 3rd, and arrived on the 5th. Assuming all the delay to have occurred on this side of Singapore, Dr. Schuster's party would have reached that place on the 24th of March, which would give them ample time to reach Chulai Point and make their preparations, especially as the colonial steamer which has been detached for the service is very swift.

It is not probable that news will be received from either of the parties for some little time, as it will probably be carried by local steamers to Rangoon, Singapore, or Calcutta.

In the meantime we take the following extracts from an article in the *Times* of Tuesday, showing the final arrangements adopted so far as they are known:—

"The advantages of scientific, and especially of astronomical expeditions, are by no means confined to the record of those special phenomena which the observers go out to see. The growing interest taken by all classes in the study of nature, while it makes a large number anxious to participate in the results obtained, at the same time puts them in presence of a class of facts which the stay-at-home student finds it hard to realise for himself. The total eclipse of the sun, which is visible in the Nicobar Islands, Burmah, Siam, and Anam to-day is a case in point. While early risers are breakfasting this morning, with the beams of the sun, low down in the east, not yet able to break through the morning mists, some quarter of the way round the world there will be at least three parties of anxious observers battling with the fierce noontide heat of that same luminary nearly overhead, soon, indeed, to have his light and heat entirely withdrawn for a time, but, all the same, under conditions so different from those we are familiar with here, that the sun and the surroundings of the observers might seem to form part of another universe. Another point—and this is one which will doubtless disappoint many—is that this eclipse, which, as we stated in a former article, on the high authority of Mr. Hind, in the time of obscurity will not be surpassed by any other available one during the present century, is totally invisible here. Although there is almost total darkness for nearly five minutes in Burmah and Siam, no trace of an eclipse will be seen in these islands, for the reason that although it began as early as two minutes to four this morning, and continued till sixteen minutes past nine, the moon's shadow falls first to the south, and then to the east of us. In fact, the line of total eclipse runs from the Cape of Good Hope to Burmah and Siam, and thence to the North Pacific. We lie, therefore, in no part of the track of the shadow.

"To pass from what may be considered geographical considerations, we may remind our readers that in a former article (the *Times*, Jan. 11, reprinted in *NATURE*, p. 201) we pointed out the value which many men of science attached to securing observations of this eclipse, and we attempted to give a general statement of the various questions pressing for solution, which, in the opinion of the Council of the Royal Society, justified an application to the Government for aid, not only in sending out expeditions from this country, but in organising a party of observers in India. Our readers have also been informed (the *Times*, Jan. 16) of the fact that the application to Government was at once acceded to in the warmest manner, and that Sir Stafford Northcote, the Marquis of Salisbury, and the Viceroy of India, as well as the Admiralty authorities, have been unceasing in the encouragement and assistance which they

have afforded. Nor was this all. The assistance afforded by the directors of the Peninsula and Oriental Steam Navigation Company in aid of the grant from Government was of so material a kind that the committee were enabled to send no less than six fully equipped observers from Europe to take part in the observations, as well as spare instruments for the use of the Indian parties.

"As a final result of all the efforts made, both in England and India, the location and composition of the various parties this morning, so far as is known, are as follows:—

"Camorta, in the Nicobars.—Capt. Waterhouse, Messrs. Meldola and Reynolds.

"Mergui (British Burmah).—Professors Pedler, of Calcutta; Tacchini, of Palermo; and Vogel, of Berlin, and assistants.

"Chulai Point (Siam).—Dr. Janssen and assistants, Dr. Schuster, Messrs. Lott and Beasley.

"The Royal Society Committee will certainly have to be congratulated if it has really been able to secure the valuable co-operation of all the distinguished foreign workers it has enrolled. We know that Herr Vogel joined at Suez, and that Prof. Tacchini, who was in India when the invitation reached him, joined at Calcutta, and that his instruments, which had been despatched to Europe, were only stopped by telegram at Aden; but with regard to Dr. Janssen, it is not yet known whether he really joined at Singapore or not; indeed, no telegram has yet been received from the Siam party since they left Galle, and there parted from the Camorta party, which was then transhipped to the *Enterprise*, a despatch boat belonging to the Indian Government, which left Calcutta on the 11th of March, having Capt. Waterhouse and Professors Tacchini and Pedler, with their assistants, on board. The *Enterprise* was to land the Camorta party and then proceed to Mergui to establish a second station. We may also mention that the Siam party was to proceed from Singapore to Siam on board the steamer belonging to the Government of the Straits Settlement, the *Charybdis* having been disabled by an accident.

"From this digression as to arrangements we may return to the question of *personnel*. In no eclipse expedition, perhaps, has such a large percentage of the observers been under fire before. Dr. Schuster and Mr. Meldola, the chiefs of the English part of the Siam and Camorta expeditions respectively, and Mr. Lott, are the only ones who have not taken part in the observation of former eclipses. Mr. Reynolds assisted Mr. De la Rue to photograph the eclipse of 1860. Professors Tacchini, Vogel, Pedler, and Mr. Beasley formed part of the expeditions of 1870. Capt. Waterhouse assisted Major Tennant to obtain the beautiful series of photographs of the eclipse of 1871 at Ootacamund, which are so valuable when taken in connection with those obtained at Baikul by the British Association party. With regard to Dr. Janssen, we are unable to say how many eclipses he has seen; he has certainly been at most which have occurred since 1860, if not before that date.

"With regard to the objects to be obtained and the instruments to be employed, the instructions drawn up by the Royal Society, and issued to the observers by its authority, come to our aid, and, by the minute and careful references to each instrument and to each part of the attack which they contain, enable us almost to picture to ourselves each observing party with its complement of telescopes and prismatic cameras, the 'time-teller' going through his terribly responsible task, the silent activity of the photographic 'dark room,' and, above all, the ever-sharpening 'cusps,' and final total extinction of the Lord of Day—an extinction out of which, however, is born one of those sights for gods and men, which, once seen, so impress every power of the mind that they can ever afterwards be recalled as transcendent instances of the beauty and glory which attach themselves

to some of the rarest as well as to some of the more common phenomena of nature.

"The most striking thing about the Royal Society programme is its simplicity. For the first time in eclipse expeditions, no eye observations are arranged for; all the phenomena are to be photographically recorded. Here we see the enormous advance which has lately been made in these studies; for we may remind our readers that in 1871, when the Astronomical Society were appealed to to use their influence to secure observations of the eclipse of that year, a committee of that Society would not agree to employ photography at all!

"There is another point. It is now more than probable that not even polariscopic observations will be attempted, although, thanks to the care of Mr. Spottiswoode, arrangements have been made for photographing the polariscopic corona, as it may be called, if a spare observer presents himself.

"The ground has been cleared in yet another way. The photographs of the corona, which were so strongly insisted upon by Mr. Lockyer in the observations of the eclipse of 1871, and objected to by the Astronomical Society, were necessary to determine the solar or non-solar origin of the corona. This question has now been set at rest by showing that part of it is really at the sun, and this is now termed the coronal atmosphere. When this was settled, it was suggested by the same observer that this atmosphere would be very likely found to vary in shape and dimensions with the sun-spots. This is the question, then, that is to be attacked in the old way on this occasion; and, on the suggestion of the Royal Society Committee, the Viceroy has charged Capt. Waterhouse with this duty. He will use the same instrument that was used by Major Tennant and himself in 1871, on Doda-betta.

"The instruments termed 'prismatic cameras' are ordinary 3½-inch achromatics, with a large prism of small angle outside the object-glass, and a camera replacing the eye-piece. Such an instrument will give a spectra of small dispersion.

"Of course with such an instrument as this employed on the full sun, the impression on the plate would be a blurred spectrum containing no detail, but as the advancing moon reduces the part of the sun still remaining visible to a thin silver crescent, then the instrument will begin its work; the actual shape and thickness of each stratum of vapour above the photosphere will be impressed by each coloured ray its light contains, and will stand out on a band of continuous spectrum, which will get feebler and narrower as the silver crescent thins to nothingness. Then the whole ring of chromosphere and coronal atmosphere which will burst upon the eye will be sorted out, if all goes well, into its various metallic constituents, by means of a chain of rings of greater or less thickness and regularity upon the photographic film. The vapours extending furthest outwards from the photosphere will be represented by the broadest rings, those lying closest to the photosphere by the narrowest. The Instructions are careful to insist upon complete rehearsals before the day of the eclipse, so that we may be assured that the simple programme we have sketched may be simply carried out, and that the observers will not attempt too much. It is as well to state this because persons unaccustomed to observations might imagine from the multiplicity of detail in the Instructions that the labours of the observers will be more than ordinarily complicated.

"Each party will have a telescope and a prismatic camera. In addition to this equipment, Prof. Pedler will use a heliostat, focussing the image of the sun on a spectroscope from which the slit has been removed. As a camera, he uses a Janssen slide, which he has arranged so as to get thirty pictures.

"We are reminded incidentally by the Instructions on 'the multiplication of results,' of the enormous advan-

tage of the photographic method; there is no chance of error or forgetfulness. The observations sent home to the Royal Society will enable those on whom the labour and responsibility of reducing them will fall to almost reconstruct the eclipse for themselves.

"We may remark in conclusion that not only may we hope for many important results in solar physics if the weather be favourable, but that the benefit to science arising out of the expedition will be by no means limited to the eclipse results. Already Drs. Vogel and Schuster, the latter of whom is a distinguished pupil of Owens College, have done some important work on the varying intensities of the different parts of the solar spectrum at different times of the day, and in different climates on the voyage out, but both will remain some months in India to pursue their inquiries—Dr. Vogel in photographing the solar spectrum, with variously coloured photographic films; Dr. Schuster in establishing himself at a considerable height for the purpose of photographing the various solar phenomena and the spectra of some of the most important of the southern stars. The observers, all of whom have made considerable sacrifices in travelling a quarter round the globe and back again in the pursuit of science, certainly command our sympathy and deserve success. The Government grant of 1,000*l.* has been the means of calling forth, and, we hope sincerely, rendering fruitful, a vast amount of individual effort which would have been powerless without it. We may add that all the instruments have either been purchased by the Royal Society out of its own funds or lent by private individuals."

#### ON THE DISSIPATION OF ENERGY\*

THE second law of thermodynamics, and the theory of dissipation founded upon it, has been for some years a favourite subject with mathematical physicists, but has not hitherto received full recognition from engineers and chemists, nor from the scientific public. And yet the question under what circumstances it is possible to obtain work from heat is of the first importance. Merely to know that when work is done by means of heat, a so-called equivalent of heat disappears, is a very small part of what it concerns us to recognise.

A heat-engine is an apparatus capable of doing work by means of heat supplied to it at a high temperature and abstracted at a lower, and thermodynamics shows that the fraction of the heat supplied capable of conversion into work depends on the limits of temperature between which the machine operates. A non-condensing steam-engine is not, properly speaking, a heat-engine at all, inasmuch as it requires to be supplied with water as well as heat, but it may be treated correctly as a heat-engine giving up heat at 212° Fahr. This is the lower point of temperature. The higher is that at which the water boils in the boiler, perhaps 360° Fahr. The range of temperature available in a non-condensing steam-engine is therefore small at best, and the importance of working at a high pressure is very apparent. In a condensing engine the heat may be delivered up at 80° Fahr.

It is a radical defect in the steam-engine that the range of temperature between the furnace and the boiler is not utilised, and it is impossible to raise the temperature in the boiler to any great extent, in consequence of the tremendous pressure that would then be developed. There seems no escape from this difficulty but in the use of some other fluid, such as a hydrocarbon oil, of much higher boiling point. The engine would then consist of two parts—an oil-engine taking in heat at a high temperature, and doing work by means of the fall of heat down to the point at which a steam-engine becomes available; and

secondly, a steam-engine receiving the heat given out by the oil-engine and working down to the ordinary atmospheric temperature.

Heat-engines may be worked backwards, so as by means of work to raise heat from a colder to a hotter body. This is the principle of the air or ether freezing machines now coming into extensive use. In this application a small quantity of work goes a long way, as the range of temperature through which the heat has to be raised is but small.

If the work required for the freezing machine is obtained from a steam-engine, the final result of the operation is that a fall of heat in the prime mover is made to produce a rise of heat in the freezing machine, and the question arises whether this operation may be effected without the intervention of mechanical work. The problem here proposed is solved in Carré's freezing apparatus, described in most of the text-books on heat. There are two communicating vessels, A and B, which are used alternately as boiler and condenser. In the first part of the operation aqueous ammonia is heated in A, until the gas is driven off and condensed under considerable pressure in B, which is kept cool with water. Here we have a fall of heat, the absorption taking place at the high temperature and the emission at the lower. In the second part of the operation A is kept cool, and the water in it soon recovers its power of absorbing the ammonia gas, which rapidly distils over. The object to be cooled is placed in contact with B, and heat passes from the colder to the hotter body. Finally, the apparatus is restored to its original condition, and therefore satisfies the definition of a heat-engine. M. Carré has invented a continuously working machine on this principle, which is said to be very efficient.

Other freezing arrangements depending on solution or chemical action may be brought under the same principle, if the cycle of operations be made complete.

When heat passes from a hotter to a colder body without producing work, or some equivalent effect such as raising other heat from a colder to a hotter body, energy is said to be dissipated, and an opportunity of doing work has been lost never to return. If on the other hand the fall of heat is fully utilised, there is no dissipation, as the original condition of things might be restored at pleasure; but in practice the full amount of work can never be obtained, in consequence of friction and the other imperfections of our machines.

The prevention of unnecessary dissipation is the guide to economy of fuel in industrial operations. Of this a good example is afforded by the regenerating furnaces of Mr. Siemens, in which the burnt gases are passed through a passage stacked with fire-bricks, and are not allowed to escape until their temperature is reduced to a very moderate point. After a time the products of combustion are passed into another passage, and the unburnt gaseous fuel and air are introduced through that which has previously been heated. The efficiency of the arrangement depends in great degree on the fact that the cold fuel is brought first into contact with the colder parts of the flue, and does not take heat from the hotter parts until it has itself become hot. In this way the fall of heat is never great, and there is comparatively little dissipation.

The principal difficulty in economy of fuel arises from the fact that the whole fall of heat from the temperature of the furnace is seldom available for one purpose. Thus in the iron smelting furnaces heat below the temperature of melting iron is absolutely useless. But when the spent gases are used for raising steam, the same heat is used over again at another part of its fall. There is no reason why this process should not be carried further. All the heat discharged from non-condensing steam-engines, which is more than nine-tenths of the whole, might be used for warming or drying, or other operations in which only low temperature heat is necessary.

The chemical bearings of the theory of dissipation are

\* A lecture given at the Royal Institution on Friday, March 5, 1875, by Lord Rayleigh, M.A., F.R.S., M.R.I.

very important, but have not hitherto received much attention. A chemical transformation is impossible, if its occurrence would involve the opposite of dissipation (for which there is no convenient word); but it is not true, on the other hand, that a transformation which would involve dissipation must necessarily take place. Otherwise, the existence of explosives like gunpowder would be impossible. It is often stated that the development of heat is the criterion of the possibility of a proposed transformation, though exceptions to this rule are extremely well known. It is sufficient to mention the solution of a salt in water. This operation involves dissipation, or it would not occur, and it is not difficult to see how work might have been obtained in the process. The water may be placed under a piston in a cylinder maintained at a rigorously constant temperature, and the piston slowly raised until all the water is evaporated, and its tension reduced to the point at which the salt would begin to absorb it at the temperature in question. After the salt and vapour are in contact, the piston is made to descend until the solution is effected. In this process work is gained, since the pressure under the piston during the expansion is greater than at the corresponding stage of the contraction. If the salt is dissolved in the ordinary way energy is dissipated, an opportunity of doing work at the expense of low temperature heat has been missed and will not return.

The difficulty in applying thermodynamical principles to chemistry arises from the fact that chemical transformations cannot generally be supposed to take place in a reversible manner, even although unlimited time be allowed. Some progress has, however, recently been made, and the experiments of Debray on the influence of pressure on the evolution of carbonic anhydride from chalk throw considerable light on the matter. By properly accommodating the pressure and temperature, the constituents of chalk may be separated or recombined without dissipation, or rather dissipation may theoretically be reduced without limit by making the operation slowly enough.

The possibility of chemical action must often depend on the density of the reacting substances. A mixture of oxygen and hydrogen in the proper proportions may be exploded by an electric spark at the atmospheric pressure, and energy will be dissipated. In this operation the spark itself need not be considered, as a given spark is capable of exploding any quantity of gas. Suppose, now, that previously to explosion the gas is expanded at constant temperature, and then after explosion brought back to the former volume. Since in the combination there is a condensation to two-thirds, the pressure required to compress the aqueous vapour is less than that exercised at the same volume by the uncombined gases, and accordingly work is gained on the whole. Hence the explosion in the expanded state involves less dissipation than in the condensed state, and the amount of the difference may be increased without limit by carrying the expansion far enough. It follows that beyond a certain point of rarity the explosion cannot be made, as it could not then involve any dissipation. But although the tendency to combine diminishes as the gas becomes rarer, the heat developed during the combination remains approximately constant.

It must be remembered that the heat of combination is generally developed at a high temperature, and that therefore work may be done during the cooling of the products of combustion. If, therefore, it is a necessity of the case that the act of combustion should take place at a high temperature, the possibility of explosion will cease at an earlier point of rarefaction than would otherwise have been the case.

It may probably be found that many mixtures which show no tendency to explode under ordinary conditions will become explosive when sufficiently condensed.

## NOTES

THE *Bonner Zeitung* publishes a letter of Dr. Seeliger, containing the first detailed reports from the German party of observers sent to the Auckland Islands to observe the Transit of Venus. Dr. Seeliger speaks of the weather in these islands as the most wretched imaginable; enough, he says, to drive an astronomer to despair. "Clear evenings are very rare, and sunshine a phenomenon." On Dec. 9, at 12.45 P.M., "Venus was to appear on the sun's disc; one minute passes after another, and still all is covered. At last the clouds thin a little, and without dark glass we can easily see Venus, that had just entered on the sun's disc. The two first contacts, which, however, were of less value to us, were lost therefore. A quarter of an hour afterwards a little gap shows itself in the clouds, the sun breaks through, and we at once set to work, so as not to lose a single moment. And now comes the wonder! For nearly four hours the sun remains completely free from clouds. In the east and in the west thick clouds; only where the sun stands it is clear. Hardly has Venus passed off the sun's disc, therefore hardly have we completely succeeded with our measurements, when the sky is again overcast all over. To-day the day is dull, as usual. As affairs stand we shall very likely have to stop here two or two-and-a-half months longer, because we have not yet been able to do anything for the other astronomical data, which are indispensable. On the one hand it is hardly possible to do anything in this climate at this time, and then we finished our general preparations only a long time after we thought we should do so."

WE regret to record the death of Carl Ludwig Christian Becker, who has for so long been known to students of physical science in this country in connection with the firm of Elliott Brothers. He was born at Ratzeburg, in the Grand Duchy of Mecklenburg Strelitz, July 16, 1821, and received his general education at the Gymnasium of his birthplace, of which his father was Rector. He studied his profession with Repsold at Hamburg, Kraft at Vienna, and Steinheil at Munich, and came to London in 1849, joining the firm of Elliott Brothers in 1858. Within the last few years he became a member of the Society of Telegraph Engineers and Fellow of the Royal Astronomical and Physical Societies. We believe that there is no one who has pursued physical inquiries in England who will not look upon his loss as that of a personal friend, while his skill in providing new appliances for investigation reminds us how often the most important scientific work is dependent upon the skilled mechanic.

THE Royal Academy of Medicine at Brussels has given its opinion on the so-called "miracle," Louise Lateau, who, it is said, by divine assistance abstains from taking food, and has done so for years together. Moreover, this miraculous creature has some wounds in her hands, side, and feet, which are said to be true representations of those of Christ, and which bleed profusely every Friday. Dr. Virchow, the celebrated German anatomist, has made her the subject of a little pamphlet, "Ueber Wunder." The opinion of the Brussels Academy, which is quite in accordance with that of Dr. Virchow, is as follows:—"Louise Lateau works and requires heat; every Friday she loses a certain quantity of blood by her wounds. When she breathes, she exhales water vapour and carbonic acid; her weight has not decreased since she has been observed; she therefore consumes carbon which is not furnished by her system: Where does she take this carbon from? Physiology simply replies, 'She eats.' The alleged abstinence from all food of Louise Lateau is contradictory to all physiological laws; it is therefore hardly necessary to prove that this abstinence is an invention. Whoever alleges that Louise Lateau is not subject to physiological laws, must prove it; until this is done physiology will denote the miracle to be a deception." Could Louise Lateau be



closely observed night and day by scientific men, the deception would soon come to light. It is of no use to talk of miracles, even when eleven doors are shut against deceit, as long as the twelfth is left open."

THE International Congress on Silk-culture is to hold its fifth meeting at Milan during 1876. The Committee has sent a programme of experiments to be made during 1875 to all silk-culturists of Europe. This programme treats of the most important questions connected with the keeping of silkworms, the prevention of their diseases, particularly of their "inactivity;" the latter is a disease which has done great damage of late years. M. Pasteur has proposed as a remedy to isolate the deposits of ova into separate cells; but this has proved totally ineffective. However, with investigators like Cornalia, Duclaux, Bolle, and others, on this field, it may safely be expected that means and ways will soon be found to prevent any serious diseases from raging among silkworms and their ova.

SWEDISH newspapers report the discovery of a large deposit of hematite iron ore in the district of Nordland, Norway, some fifteen or twenty miles from Bodö, and only about ten or twelve miles from a Norwegian port which is completely free from ice. The analysis of the ore shows that it contains between fifty-four and sixty-seven per cent. of iron, and only a very small percentage of phosphates.

PROF. Haeckel, of Jena, has been lecturing at the Karlsruhe Museum on the coral reefs of the Red Sea. Prof. Michelis has asked him in the *Karlsruher Zeitung* whether he will give him the opportunity of a public discussion. It is said that Dr. Michelis will soon publish a purely scientific refutation of "the German Darwin's" *Anthropogeny*.

*Dingler's Polytech. Journal* contains an account of researches made by Dr. Otto Krause, of Annaberg, on tobacco smoke, which he finds contains constantly a considerable quantity of carbonic oxide. The after effects of smoking are said to be principally caused by this poisonous gas, as the smoker never can prevent a part of the smoke from descending to the lungs, and thus the poisoning is unavoidable. The author is of opinion that the after effects are all the more energetic, the more inexperienced the smoker is, and he thus explains the unpleasant results of the first attempts at smoking, which are generally ascribed to nicotine alone.

A MALADY which threatens great loss to owners of lemon plantations has attacked the lemon plant, the origin of which is believed to be the forced cultivation of the fruit, which has taken place during the last few years. The lemon plant is very hardy, and infinitely easier to cultivate than the orange, and this fact has probably induced a certain amount of carelessness in its treatment, from which growers are now suffering. The tree was originally a native of the dry and hot soil of Persia, whence it has been transferred to various other countries, where, under different circumstances of soil and climate, it has been made largely to increase its yield of fruit. The disease which has now made its appearance is called *la sécheresse*, or dry rot, and seizes the extremities of the plant, sometimes the roots, sometimes the branches, whence it gradually spreads through the whole tree, drying up its sap in its course. Hitherto attempts have been made to check the ravages, of the new disease, but without success. It is said that similar appearances have been noticed in orange plantations. It is suggested that by grafting cuttings of the healthy lemon plant on the wild orange tree, a new stock of plants may be obtained, and the fruit cultivated on trees which have not been subjected to forced growth. If this plan succeeds, it is to be hoped that the cultivation of the new race may be carried on with greater care in the future.

VICE-CONSUL ALLEN, in his report of the trade of Tamsuy and Kelung, describes the distillation of the camphor of commerce from *Cinnamomum camphora*, Fr., Nees et Eb., as a most hazardous trade, the distillers having to be constantly on the alert for fear of attack by the aborigines, who are naturally opposed to the continual encroachments into their territory for the purpose of cutting down the trees for extracting the camphor. No young trees are planted to replace those cut down, nor do the officials take any cognisance of the diminution which is being surely effected in the supply of a valuable commercial article. The stills are described as being of a very simple construction, and are built up in a shed in such a manner that they can be moved as the Chinese advance into the interior. A long wooden trough, coated with clay and half filled with water, is placed over eight or ten furnaces; on the trough boards pierced with holes are fitted, and on these boards are placed jars containing the camphor-wood chips, the whole being surmounted by inverted earthenware pots, and the joints made air-tight by filling them up with hemp. When the furnaces are lit the steam passes through the pierced boards, and saturating the chips, causes the sublimated camphor to settle in crystals on the inside of the pots, from which it is scraped off and afterwards refined. During the summer months the camphor often loses as much as 20 per cent. on its way from the producing districts to the port of shipment.

MR. BARNUM is said to have made an agreement with Mr. Donaldson, the aeronaut of the U.S. *Daily Graphic*, to build six balloons of 70,000 cubic feet each, and to make ascents next spring and summer, in order to ascertain whether there is a current from America to Europe. The sum paid to Donaldson as fees is said by the *New York World* to be 4,000*l.*

THE Clothworkers' Company have founded in King's College, London, one annual exhibition of 2*½*l. for two years for proficiency in science, open not only to actual students of the College, but to all under nineteen years of age who are intending to devote themselves to the study of mathematics, mechanics, physics, chemistry, botany, and zoology. Each candidate may select any four of these subjects.

DR. EDOUARD HITZIG, of Berlin, who is well known for his researches on the functions of the brain, has been elected to the chair of Psychology in the University of Zürich.

PROF. ARMSTRONG, of the London Institution, and Mr. E. J. Mills, D.Sc., Assistant Examiner in Chemistry in the University of London, are candidates for the vacant Jacksonian Professorship of Natural and Experimental Philosophy in Cambridge University. The other candidates are Mr. W. N. Hartley, Mr. James Stuart, and the Rev. J. C. W. Ellis.

MR. A. H. GARROD, of King's College, Cambridge, has been appointed Fullerian Professor of Physiology to the Royal Institution for the next three years.

A TELEGRAM has been received by the Berlin African Society from Lisbon announcing that Herr Homeyer, the African traveller, had safely reached Loanda, whence he proposed starting for the interior on the 11th of February. Herr Homeyer had been everywhere very well received.

THE Scottish Meteorological Society, through its president, the Marquis of Tweeddale, has addressed to Sir Stafford Northcote a letter urging the claims of that Society on Government for support. As our readers are aware, this is not the first time this Society has urged its claims for assistance on Government; it is advantageously situated, and has done very much both for the advancement of the science of meteorology and for the practical application of its results in directions beneficial to the country at large. It assuredly deserves the countenance of the Government,

were it for nothing else than the practical results of its labours, and we have no doubt that the statements forwarded to the Chancellor of the Exchequer will be seriously considered, with the result that the prayer of the Society will be granted.

We take the following from the *Times*:—The vote proposed this session for Aid to the Science Commission is but 597. It is fully expected that the labours of the Commission will be completed by the end of December; but there is much work yet in hand. Five reports have been published, and five more are in preparation, on—1, Science Teaching in Public and Endowed Schools; 2, the University of London; 3, the Scotch Universities; 4, the Irish Universities; 5, the Advancement of Science. Reports on science teaching in public and first-grade schools in England and on the aid given by the State to science in France have been prepared by the secretary. It is proposed that three of the Commissioners should visit the various colleges in Germany to make inquiry with regard to scientific instruction and the advancement of science in that country.

FROM the Annual Report of the Geologists' Association, we learn that that Society is in a prosperous condition. The increase to its numbers during last year was thirty-one, and the total number of members of all classes was, on Jan. 1st, 339.

THE *soirée* of the Paris Observatory, which took place on the 1st of April, was a very brilliant one. The saloons were crowded with provincial *savants* and their families. The great glass of the new reflector had been arranged on its edge in the Meridian Hall, so that visitors might admire the perfection of its polish. The company retired at a late hour, and on the following morning, we regret to say, M. Leon Leverrier, the eldest son of the illustrious astronomer, was found dead in his bed. He was thirty-seven years of age, a pupil of the Polytechnic School, and the consulting chemist of the Western Railway.

THE competition for prizes in connection with the University of Aberdeen, to which we alluded in our number for March 25 (p. 413), is, we are informed, confined to those who were matriculated students of the University during Session 1874-75.

THE African explorer, Dr. Mauch, who fell from a window at Blaubeuren on the 27th ult., died on the 4th inst.

WE have received from Dr. H. Hildebrand Hildebrandsson, of Upsal, a valuable paper just published on the upper currents of the atmosphere. Systematic observations of the movements of the cirrus cloud were set on foot at most of the Meteorological Stations in Sweden in December 1873. This paper, which is an able discussion of these observations, is an important contribution to the vital question of the circulation of the atmosphere; we shall give a detailed notice of it in an early number.

AN international conference for telegraphy will be held at St. Petersburg on the 1st of June. Twenty-four nations and twenty submarine companies are said to have agreed to send delegates to deliberate on a new telegraphic convention.

BY the will of the late Mr. James Young, of Bournemouth, the testator leaves, amongst other legacies, the sum of 100*l.* to John Stenhouse, M.D., F.R.S., to show his appreciation of his services to mankind by the great discovery of charcoal as an air-filterer.

PART 3 of *Petermann's Mittheilungen* contains the beginning of a report on Livingstone's travels in Central Africa, from 1866 to 1873, with extracts from his journals, and a large map drawn by Petermann after the English edition of Livingstone's journals. Even the most recent discoveries are entered on the map; for instance, the outlet of the Tanganyika Lake, discovered by Cameron, by which this lake is in direct communication with the source-district of the Congo, which Livingstone visited,

without being able, however, to discern all its relations and connections. It is very doubtful whether in England a map can already be found, which is in the least to be compared to that of Petermann.

THE *conversazione* of the Royal Society, which we announced in a recent number, took place last evening; we hope to be able to give details next week.

SUPPLEMENT No. 40 of *Petermann's Mittheilungen* consists of a detailed description of the Alpine region lying between the valleys of the Rhine and the Inn, the author being A. Wallenberg. It is accompanied by one large general and two smaller special maps.

THE meeting of the delegates of the French learned societies was inaugurated on the 31st March, and was held on the 1st and 2nd of April, at the Sorbonne. The concluding *séance* was occupied with the distribution of rewards, under the presidency of M. Wallon, the new Minister. M. Wallon gave a summary account of all the works which are carried on with the help of Government. He alluded to a recent law passed by the National Assembly, and which now regulates grants to travelling expeditions. A special commission has been established to appoint explorers and determine the amount of money required in each case in order to fulfil the ends of the journey. Each person sent out has to write an account of the work done, and the commission must report on the value of results thus obtained.

A NEW notation for thermometers has been invented by the present director of the Copenhagen Meteorological Board, and consists merely in taking the complement to 100° of each negative degree. Although it has been intended for the Celsius thermometer, it can be extended to Fahrenheit with much advantage in the rare cases in which negative degrees are used on that scale. Suppose the following series of temperatures has been obtained: +7 - 3 + 1 - 5 + 4 - 3 - 2 + 5, for the minimum of successive days in March, according to the new style it should run so: +7 +97 +1 +95 +4 +97 +98 +5. The sum is 404 minus 400 = 4. Mean is equal to  $\frac{4}{6} = \frac{2}{3}$ . If possible, it is more difficult with Fahrenheit than with Celsius to commit any error, and means are taken with each scale with an equal facility.

FROM the Tenth Quarterly Report of the Sub-Wealden Exploration, we learn that the total depth of the new boring commenced February 11 is 373 feet. From the surface to the gypsum, say about 127 feet, the beds consist of alternating shales, limestones, and calcareous clays, all effervescing with acid; more or less fissured, varying in compactness and hardness from that of Purbeck kerbstone to that of Windsor soap. A considerable thickness, over 30 feet, of pale grey sand and sandstone immediately succeeds the gypsum, followed by calcareous shales, to the Kimmeridge clay at about 290 feet. This sand is supposed by the authorities to be the representative of the Portland series. It contains casts of annelides and the claws of one or two small species of crab. The report contains an account of the boring at Spereberg, about twenty-three miles south of Berlin, which was prosecuted to a depth of 4,172 feet.

THE additions to the Zoological Society's Gardens during the past week include a Red-bellied Wallaby (*Halmaturus billardieri*) from Tasmania, a Vulpine Phalanger (*Phalangerista vulpina*) from Australia, presented by Mr. Bolton Glanville Corney; a Lesser Sulphur-crested Cockatoo (*Cacatua sulphurea*) from Moluccas, presented by Mr. William Holborn; a Crowned Partridge (*Rollulus cristatus*) from Moluccas, presented by Mr Barclay Field; an Indian Python (*Python molurus*) from India, presented by Mr. A. J. S. Terris; a Nisanas Monkey (*Cercopithecus pyrrhonotus*) from Nubia, deposited; a Wheatear (*Saxicola ananthe*) European, purchased.

## SOCIETIES AND ACADEMIES

## LONDON

Royal Society, March 18.—“On the Absorption-Spectra of Metals volatilised by the Oxyhydrogen Flame,” by J. Norman Lockyer, F.R.S., and W. Chandler Roberts, Chemist of the Mint.

The authors state that the researches which have recently been published on the absorption-spectra of various metals, first by Roscoe and Schuster, and subsequently by one of themselves,\* establish beyond all question the facts that—

1. In addition to the well-known line-spectra; channelled-space spectra are produced by the vapours of certain metals; and,

2. Such spectra are produced by vapours which are competent to give, at other times, not only line-spectra, but continuous spectra in the blue, or blue and red.

As the temperature employed for the volatilisation of the metals in these experiments did not exceed bright redness, the range of metals examined was necessarily limited. It was therefore considered desirable to extend these observations to the less fusible metals, as well as to ascertain whether the spectra of those which volatilised at the lower temperature would be modified by the application of a greater degree of heat. For this purpose they employed an oxyhydrogen blowpipe, and the lime still used by Stas for the distillation of silver, his arrangement being modified in order that the metallic vapour might be conducted into a lime tube or tunnel heated to whiteness, so placed that a beam from an electric lamp could readily traverse it.

The apparatus employed consists of a block of lime traversed by a tube 16 centims. long and 30 millims. diameter. A receptacle, open at the upper surface of the lime-block, in order to admit of the introduction of the oxyhydrogen blow-pipe, communicates with the centre of the tube. The ends of the tube or tunnel in the lime were closed by glass plates held on by a suitable clip. Small lateral orifices were cut in the lime for the insertion of tobacco-pipe stems, through which a stream of hydrogen could be passed into the tube and receptacle.

An electric lamp was placed opposite one end of the tube and a spectroscopie opposite the other. This last instrument was by Desaga, of Heidelberg, and its single prism, the angle of which was 60°, was capable of distinctly separating the D lines, at the same time that it enabled us to see the whole spectrum in a single field of view, an essential point in such inquiries.

Some preliminary experiments indicated the advisability of increasing the length of the column of vapour. To effect this, a tube 30 centims. long was made in a fresh block of lime, the cavity being arranged as before; in each end a short accurately fitting iron tube, luted with a mixture of graphite and fire-clay, was inserted; and the total length of the column thus became 60 centims.

The lime-block with its fittings was then placed in a charcoal furnace, by means of which the whole could be raised to a high temperature. As soon as the block was heated to bright redness, the metal, the vapour of which was to be examined, was introduced into the receptacle, and the flame of the oxyhydrogen blowpipe was allowed to play on its upper surface, care being taken to employ an excess of hydrogen. In almost every case the metal experimented on was rapidly volatilised (the exceptions being gold and palladium). As the glass plates rapidly became clouded by the condensation of the metallic vapours, it was necessary to adopt an arrangement by which they could be easily replaced. The authors assured themselves that oxides were not present to disturb the accuracy of the results.

They ascertained that the effect of oxides, and of the metallic rain due to condensation, was to produce a general absorption obviously different from the special effects of absorption which they record. Silver may be given as an example of the method.

Fifty grammes of pure metal were placed in the cavity, and this amount produced a continuous supply of vapour for about ten minutes.

With the smaller thickness given by the first lime block, and with a less powerful blast, the spectrum of silver consisted of an absorption in the blue which at times extended almost to the green.

With the elongated tube and a stronger blast an exquisite channelled-space absorption was observed, the channels being far enough apart to render them very conspicuous in the field of view; at the same time there was continuous absorption in the

blue. It was specially observed that there was no absorption in the red:

The results of experiments on the following metals and metalloids are then described:—Copper, sodium, calcium, aluminium, zinc, cadmium, manganese, iron, cobalt, nickel, chromium, tin, antimony, bismuth, lead, thallium, gold, palladium, selenium, and iodine.

The authors conclude that these experiments, conducted at the high temperature of the oxyhydrogen flame, go far to support the conclusions which were drawn from the experiments at a lower temperature. First, in passing from the liquid to the most perfect gaseous state, vapours are composed of molecules of different orders of complexity; and second, this complexity is diminished by the dissociating action of heat, each molecular simplification being marked by a distinctive spectrum. There is also an intimate connection between the facility with which the final stage is reached, the group to which the element belongs, and the place which it occupies in the solar atmosphere.

“On Traumatic Inflammation of Connective Tissue,” by G. Thin, M.D. Communicated by Prof. Huxley, Sec. R.S.

Linnean Society, April 1.—Dr. G. J. Allman, F.R.S., president, in the chair.—The President, on taking the chair, said: “I cannot allow the business of the evening to commence without one word expressive of the deep sorrow which we all feel in the death of one of our most distinguished Fellows and ablest officers. In our late treasurer we had a man of refined and cultivated mind, of honest and straightforward purpose, and of a simplicity and kindness of character that endeared him to all who knew him. Mr. Hanbury has been taken away from us at a time of life when we might still have looked forward to much and valuable work, and it now only remains for us to accept in sorrow the loss which deprives the Society of a conscientious and efficient officer, and many of us of a valued friend.”—The following papers were read:—Notes on *Octopus vulgaris*, Lam., by Mr. W. S. Mitchell.—On the connection of vegetable organisms with small-pox, by Dr. E. Klein, Assistant-Professor at the Laboratory of the Brown Institution. A report of this paper will shortly appear in the Proceedings of the Royal Society.

Chemical Society, April 1.—Prof. Abel, F.R.S., in the chair.—Researches on the action of the copper-zinc couple on organic bodies (viii.): on chloroform, bromoform, and iodoform, by Dr. J. H. Gladstone and Mr. A. Tribe, was read by the latter.—Dr. W. A. Tilden then read a paper on the action of nitrosyl-chloride on organic bodies (ii.): on turpentine oil. The action gives rise to a molecular compound of terpine and the chloride, which by the action of alcoholic potash, yields nitroso-terpine,  $C_{10}H_{15}NO$ .—Dr. A. W. Hofmann made two communications to the Society: one, on the decomposition of the fulminates by ammonia and by sulphuretted hydrogen; the other, a striking lecture experiment showing the atomic relations of oxygen and chlorine.

Royal Horticultural Society, March 17.—Scientific Committee. Mr. P. Edgeworth, F.L.S., in the chair.—Flowering specimens of *Bambusa gracilis*, Hort., were sent from Trentham Gardens by Mr. Stevens.—Mr. Grote, F.L.S., sent extracts from the Proceedings of the Agri-Horticultural Society of India, relative to the growth of fungi in the interior of ant-hills: According to Dr. Cunningham the species was an *Agaricus* of the section *Lepiota*. They arise from a peculiar substance found in the ant-hills, and which probably consists of vegetable debris permeated by mycelium. According to Belt, a similar substance is found in the nests of the leaf-cutting ants of Nicaragua, and is supposed by him to serve as food, the ants cutting and storing the leaves for the sake of the fungi which are subsequently developed in the debris.—Prof. Thiseleton Dyer exhibited, under the microscope, examples of the ascospores of yeast. They were obtained by cultivating yeast on moist slabs of plaster of Paris in a damp atmosphere. After about ten days the cells of the yeast, which had been starved by this treatment, developed from two to four spores in their interior. These, when placed under appropriate conditions, were found to be capable of germinating, and so of reproducing actively growing yeast. De Seynes had observed them in *Alyceoderna viridi* in 1868, but they had been first described by Max Reess in 1870, in yeast.—Copies of the Meteorological Society's report on the observations of phenological phenomena were placed on the table.—Dr. Masters called attention to the beautiful specimen of the fruit of *Hedychium Garadnerianum*, sent by Mr. Bennett from Hatfield. It had not hitherto been known to fruit in cultivation.

\* Lockyer: Proc. Roy. Soc., v. xxii. p. 371.

General Meeting.—W. A. Lindsay, secretary, in the chair.—The Rev. M. J. Berkeley called attention to the various objects of interest exhibited.

Anthropological Institute, March 23.—Col. A. Lane Fox, president, in the chair.—The President communicated a note on the chest measurement of recruits for the army, pointing out how the departure from a uniform method of measuring gave rise to unnecessary public expenditure, and often to the loss of good and sound men to the service. The method employed by Col. Fox himself at his depot was explained, and a table of statistics was exhibited in illustration of his remarks.—The Rev. Dunbar J. Heath, M.A., read a paper entitled "Molecules and Potential Life." The object of the author was to adduce arguments to show that there is a physical foundation for the measurement of vitality. The labours of Dr. Lionel Beale enabled us to put the amount of protoplasm, or living matter in the adult human body, at about 15lbs. in weight. Every vital action of every sort or kind kills a portion of that matter, and the mechanism by which its death is compensated, by the vitalisation of fresh pabulum, was anatomically and physiologically described. Hence it followed that every unit of physical action corresponds to the death of a unit of protoplasm, and a unit of vital action is at the same time exhibited. The death of protoplasm at the outside of a cell was described as diminishing the velocity and therefore the pressure of the outside dissociated atoms, the consequence of which was the deposit of the proximate principles such as fibrine, &c., and a rush of fresh pabulum inwards into the cell.—Mr. G. H. Kinahan, F.G.S., contributed a paper on a prehistoric road at Duacan's Flow, Balbyalbaugh, Co. Antrim.

Entomological Society, March 15.—Sir Sidney Smith Saunders, president, in the chair.—Mr. Sealy exhibited specimens of an *Ornithoptera* bred from larvae taken in Malabar in great numbers on *Aristolochia indica*.—Prof. Westwood exhibited drawings of several undescribed Coleoptera of remarkable forms, of which he intended to communicate the descriptions. Amongst them was an insect from the collection of M. Mniszech which bore a strong resemblance to a *Rhyssalus*, and which he had named *Rhissodina Mniszechii*, but was really a Heteromorous insect.—Mr. M'Lachlan remarked that on close examination the species of *Lepisma* exhibited at the last meeting by Mr. F. H. Ward did not correspond with the description of *L. domestica* of the United States, nor with the descriptions of any species with which he was acquainted.—Mr. Butler communicated some critical remarks on the recently published work on the *Sphingidae* by Dr. Boisduval.—The Rev. K. P. Murray read some remarks on the species of *Tortax*, forming the Hecabe group, which tended to show that the insects which had hitherto been considered distinct species under the names of *Æsiope*, Mên, *Brenda*, Doubl, and Hew., and *Sari*, Horsa, were mostly, if not all, referable to but one species, *T. Hecabe*, Linn. Prof. Westwood suggested that the case might be analogous to certain species of *Pieris*, where certain forms, e.g. *P. napaæ*, Esp., and *P. Sabellæ*, Steph., now universally recognised as varieties of *P. napi*, Linn., had long been considered as specifically distinct. Prof. Westwood also suggested that attention should be paid to the times of appearance of the various forms, and the period noted during which they remained in the pupa stage. Mr. Butler remarked that the latter circumstance had an important bearing in the case of *Papilio Ajax*, Linn.—Mr. J. S. Baly communicated descriptions of new genera and species of Phytophagous Coleoptera.—Mr. C. O. Waterhouse communicated a paper on the Lamellicorn Coleoptera of Japan.—Mr. F. Smith read descriptions of new species of Indian Aculeate Hymenoptera collected by Mr. G. K. James Rothney, and also descriptions of new species of bees of the genus *Nontia*, Latreille.

Institution of Civil Engineers, March 23.—Mr. Thos. E. Harrison, president, in the chair.—The papers read were on the Hull Docks, by Sir William Wright, Assoc. Inst. C.E.; and on the construction of the Albert Dock at Kingston-upon-Hull, by Mr. John Clarke Hawkshaw, M.A., M. Inst. C.E.

Victoria (Philosophical) Institute, April 5.—Mr. C. Brooke, F.R.S., in the chair.—A paper on the relation of the Scripture account of the Deluge to Physical Science, by Prof. Challis, F.R.S., was read.

#### MANCHESTER

Literary and Philosophical Society, March 23.—Mr. Edward Schunck, F.R.S., president, in the chair.—On discoveries in a cave at Thayingen, near Schaffhausen, by Arthur Wm. Waters, F.G.S.

#### RIGA

Society of Naturalists, Sept. 2, 1874.—A number of specimens, mainly of ornithological interest, were presented to the Society by Dr. C. Berg, of Buenos Ayres, and others.—Prof. Schweder then spoke at length on self-ignition of hay; he attributes the first cause of the rise of temperature in bundles of hay to the chemical decomposition of the hay itself.

Sept. 16.—M. Behrmann spoke on the constitution of red and yellow prussiate of potash, and gave the graphic representation of both, showing the four free atomicity bonds in  $\text{Cly} (\text{Fe}^e \text{Cy}_6)$ , and the six in  $\text{Cldy} (\text{Fe}^e \text{Cy}_{12})$ .

Oct. 14.—Prof. Kieseritzky presented a number of rare species of plants for the herbarium of the Society. The paper read was "On Microscopic Investigation of Rocks," by Prof. Petzhold.—Dr. Nauck then exhibited some specimens of *Sesogoriscus pisciformis* bred by him.—The publication of the Society contains a detailed list, by J. H. Kawall, of all the work done by the new Russian societies of naturalists, and comprises the societies of Charkow, St. Petersburg, Moscow, Kasan, and Odessa.

#### STOCKHOLM

Kongl. Vetenskaps Akademiens Förhandlingar, Sept. 9 and Oct. 14, 1874.—The following papers were read:—On some peculiarities in the isothermal curves and the relations amongst different kinds of specific heats in the mechanical heat theory, by Prof. G. R. Dahlander.—On the influence of birds upon the composition of fossiliferous strata, by Dr. G. Eisen.—On two deductions from Cauchy's theorem of mathematical roots, by G. Mittag-Leffler.—On the magnetic measurement of iron ore deposits, by Prof. R. Thalén.—Calculation of the relative disturbances of planet (112) Iphigenia, by Dr. J. O. Backlund.

#### GÖTTINGEN

Royal Society of Sciences, Dec. 1874.—The following papers were read:—On the influence of the position of sun and moon upon volcanic eruptions, by S. von Waltershausen.—On the Sanskrit verbal root *śā*, and its derivatives in Greek and Latin, by Th. Benfey.—On the laws of voltaic induction, by Ed. Riecke.—On the molecular motion of two particles, with reference to Weber's law of electric force, by the same.—On the morphology and physiology of the facet eye of Articulata, by Dr. Grenacher of Rostock; an elaborate treatise on the subject, with a view to prove that the morphology of the compound eyes is perfectly compatible with Darwin's theory.

#### PARIS

Academy of Sciences, March 22.—M. M. Frémy in the chair.—The following papers were read:—Study of the process in the human mind in the research of the unknown, by aid of observation and experience, &c., by M. Chevreul. This is the author's second paper on the subject, and treats of the laws of vision and of the simultaneous contrast of colours.—On the stability of the salts of the fatty acids in the presence of water, and on the reciprocal displacement of these acids, by M. Berthelot. Mainly the alkaline salts are considered in their behaviour with excess of water, base or acid, and the acids treated of, with regard to substitution of each other, are formic, acetic, butyric, and valeric acids.—On the association of native platinum with rocks of a chrysolite base in the Ural; original relation of this metal to chromite, by M. Daubrée.—On the variations or periodical changes in the temperature (tenth note); period of the twelve-fold twentieth day, by M. Ch. Sainte Claire Deville.—The Academy then proceeded to the nomination of a new correspondent to its Mechanical Section, in lieu of the late Mr. Fairbairn. M. Boileau was duly elected in his stead.—The President then addressed a few words to M. Bouquet de la Grye, the chief of the expedition sent to Campbell Island to observe the Transit of Venus, and thanked him and the other members of the expedition, in the name of the Academy, warmly for their untiring efforts to obtain satisfactory results. After a short acknowledgment M. Bouquet de la Grye read a paper on the scientific documents recording the observations made at Campbell Island; the observations of the Transit of Venus were not successful, but the observers have brought home numerous results of other scientific observations, which in some degree atone for the disappointment with the rare phenomenon of the Transit.—A note by M. Mannheim on M. Ribaucour's paper read at the last meeting, on some properties of curves traced on surfaces.—A note by M. Moutard, on the linear differential equations of the second order.—On the quantity of oxygen which the blood can absorb at the diffe-

rent barometrical pressures, by M. P. Bret.—On the embryony of *Lamellaria perspicua*, a species of Gasteropoda, by M. A. Giard.—On the influence of the nervous system upon the respiration of insects, with special reference to *Dytiscus marginalis*, by M. E. Faivre.—On a new electro-medical galvanoscope, by M. J. Morin.—A note by M. L. Hugo, on the scientific basis of the decimal and metric system.—A memoir by M. L. A. Raimbert, on the treatment of carbuncles by sub-cutaneous injections of antivenereal liquids.—A memoir by M. Barot, on an apparatus with continuous and graduated extension for the treatment of fractured legs.—M. Churchill then made some communications relating to cholera, and MM. Crussard and Molins some on Phylloxera.—Through M. José da Silva Mendes-Lolins, the Portuguese Minister, the Academy received an original letter from Senor Manoel Godinho de Heredia, indicating the discovery of Australia by the Portuguese.—M. Boussingault then read a translation which he had made of this letter, and M. de Lesseps made some highly interesting observations on the same subject.—A note by M. Langley, director of the Alleghany Observatory, on the relative temperature in different solar regions. This is the first communication on the subject, and it treats principally of the temperature of the black nuclei of sun-spots.—A note, by M. Maurice Levy, on the theory of continued straight beams.—On the equations of the fifth degree, by M. Brioschi.—A memoir, by M. Max. Marie, on the classification of cubical integrals of terminated volumes by algebraic surfaces; geometrical definition of surfaces which are capable of algebraic cubature.—A note, by M. J. M. Gauguin, on the theory of the processes of magnetisation.—On the molecular equilibrium of solutions of chrome alum, by M. Lecoq de Boisbaudran.—On the boiling-point determinations of the chlorinated derivatives of toluene, by M. G. Hinrichs.—M. Des Cloiseaux then presented to the Academy an instrument constructed upon the indications of M. Jannettaz, for the determination of the axes of ellipses in crystals.

March 29.—M. Frémy in the chair.—The following papers were read.—On the observations of temperature, made at the Jardin des Plantes, during the meteorological year 1874, with the electrical thermometers, under naked and grass-covered soils; by MM. Becquerel and Edm. Becquerel.—Researches on sugar beet-root, by MM. E. Frémy and P. P. Dehérain.—A note by M. Des Cloiseaux, on the pyroxyenic element in the rocks associated with platinum, in the Ural.—A memoir by M. Boussingault, on the comparative analysis of glutinous biscuits and some other feculent aliments. MM. Thénard, Boulland, and Chevreul then made some remarks on this subject.—The Academy then nominated M. Joly as correspondent to its section for Zoology and Anatomy in lieu of M. P. Gervais, who was elected a member of the Academy; and a number of commissions were nominated to superintend the competitions for the different prizes of the Academy.—On the dissolution of hydrogen by metals and the decomposition of water by iron, by M. L. Troost and P. Hautefeuille; researches treating principally of iron, nickel, cobalt, and manganese.—On the chemical equilibrium among gases: iodine and hydrogen, by M. G. Lemoine.—A note by M. Fordos, on a quick way of assaying solderings containing lead.—On the influence of the roots of living plants on putrefaction, by M. Jeannel.—On the natural wells of the coarse limestone, by M. Stan. Meunier.—A note by MM. Tréve and Durassier, on the relation existing between the nature of steel and its conducting power.—A note by M. Decharme, on a new means of producing sonorous vibrations and phenomena of interference on mercury.—M. F. Garrigou then made a communication of his new researches on the mineral waters of the Pyrenees.—A memoir by M. Peaucellier, on the application of articulate systems ("à liaison complète") to the arts and the sciences of observation.—M. J. J. Cazenave then read an abridged history of the probes and urethro-vesicular sounding instruments used up to the present day.—M. de Molon, à propos of a recent communication of M. Menier, reminds the Academy of his observations which prove the necessity of crushing the nodules of phosphate of lime to render their use efficacious in agriculture.—A note by M. J. Tardres, on the reflexion of light.—A note by M. Maillard, on the treatment of cholera.—MM. B. Dugas, A. Mornard, Barthélémy, A. Bouteille, and Dupont, then made some communications on Phylloxera.—The Minister for Foreign Affairs transmitted to the Academy a letter from the French Consul at the Cape of Good Hope, announcing the arrival at Table Bay of the members of the Commission sent by the Government of the United States to Kerguelen Island to observe the Transit of Venus. The observations were generally

successful, as well as those of the English party of observers at the same island.—MM. Sivel, Crocé-Spinelli, G. and A. Tissandier, and Jobert, then announced the success of their balloon ascent made on March 23 and 24, under the auspices of the French Aéronautical Society. They remained twenty-two hours and forty minutes in the atmosphere, and they hope shortly to communicate to the Academy the scientific results of their observations and experiments.—M. Dumas then produced before the Academy the copy of a document existing in the archives of the city of Paris, and discovered there by M. Read, relating to Salomon de Caus, with a view to complete the information regarding this sage, who died in Paris in 1626.—A note by M. G. Fouré, on some consequences of a general theorem relating to an implex and a system of surfaces.—A note by M. Hugo Gylden, on a method to calculate the absolute perturbations of comets.—On the residues of the seventh power, by M. P. Pepin.—A note by M. Brioschi, on his paper read at the last meeting on equations of the fifth degree.—On the relative temperature in the different regions of the sun, by M. Langley. This is the second paper on this interesting subject (the first was read at the last meeting), and treats of the equatorial and polar regions.—A note by M. Laguerre, on a theorem of geometry. M. Ossian Bonnet then made some remarks on the subject.—On the error in Poncelet's formula relating to the evaluation of areas, by M. Chevallier.—On the double interior reflection in doubly refractive uniaxial crystals, by M. Abria.—Chemical researches on the uric group, by M. E. Grimaux.—On the Amphipoda of the Gulf of Marseilles, by M. J. D. Catta.—On the saline deposits in the lavas of the last eruptions of Santorin, by M. F. Fouqué. M. Ch. Sainte Claire Deville then made some remarks on this paper. The same gentleman presented to the Academy the meteorological observations made at Baréges, at the Plantade Station, and on the summit of the Pic du Midi. M. H. Real presented a new publication of the Society of Civil Engineers of Great Britain, and made some remarks upon it.—M. Chasles remarked on a note of M. Genocchi à propos of a recent communication of M. Roberts, on the expression of the arcs of Descartes' ovals in the function of three elliptical arcs.

## BOOKS AND PAMPHLETS RECEIVED

BRITISH.—Report of the Thirteenth Annual Meeting of the West Riding Consolidated Naturalists' Society, 1874.—Annual Report of the Geologists Association, 1874, together with List of Members and Catalogue of Library, Laws of the Association, &c. (University College).—On the Establishment in connection with the India Museum and Library, of an Indian Institute: J. Forbes Watson, M.A., M.D. (William H. Allen and Co.)

AMERICAN.—Remarks on the Family Nemophidæ: F. W. Putnam (Boston Society of Natural History).—Remarks on the Mammoth Cave and some of its Animals: Bulletin of the Essex Institute.

FOREIGN.—Les Fournis de la Suisse, Neue Denkschriften: Auguste Forel (Zürcher and Furrer, Zürich).—Expériences sur la température du Corps Humain dans l'acte de l'ascension sur les montagnes: 1st, 2nd, and 3rd series: F. A. Forel (H. Georg, Genève).—Une Variété nouvelle ou peu connue de *Gloria Eudotis* sur le lac Léman: Dr. F. A. Forel (Rouge and Dubois, Lausanne).—Carte Hydrographique du lac Léman: F. A. Forel.—Note sur les tremblements de Terre en 1871: Alexis Perrey (Académie Royale de Belgique).—Über das Studium der Mineralogie auf den Deutschen Hochschulen: Von F. Groth (Strassburg: Karl J. Tribner).—Ergebnisse der Beobachtungsstation an den Deutschen Küsten über die physikalischen Eigenschaften der Ostsee und Nordsee und d. Fischerei, January 1874 (Berlin: Wiegandt, Hempel, and Parey).—Les Bois-Indigènes et Étrangers: Adolphe E. Dupont and Bouquet de la Grye (Paris, J. Rothschild).

## CONTENTS

	PAGE
SMITH'S "ASSYRIAN DISCOVERIES" . . . . .	445
BANCROFT'S "NATIVE RACES OF THE PACIFIC STATES" . . . . .	442
OUR BOOK SHELF:—	
Quelet's "Temperature of Brussels" . . . . .	444
Lewis and Cunningham on Cholera Agents . . . . .	444
LETTERS TO THE EDITOR:—	
Ocean Waves.—Dr. J. W. BLACK ( <i>With Illustration</i> ) . . . . .	444
Walker's System of Geometrical Conics.—C. TAYLOR . . . . .	445
Destruction of Flowers by Birds.—C. ROBERTS . . . . .	446
OUR ASTRONOMICAL COLUMN:—	
Red Stars, &c. . . . .	446
The Comet of 1812 . . . . .	446
METEOROLOGY IN ENGLAND . . . . .	446
DR. BECCARI'S DISCOVERIES IN HERPETOLOGY . . . . .	447
ARCTIC GEOLOGY. By C. E. DE RANCE, F.G.S. ( <i>With Illustration</i> ). . . . .	447
THE PROGRESS OF THE TELEGRAPH, II. ( <i>With Illustrations</i> ) . . . . .	450
ECLIPSE OF THE SUN, APRIL 6 . . . . .	452
ON THE DISSIPATION OF ENERGY. By Lord RAYLEIGH, F.R.S. . . . .	455
NOTES . . . . .	455
SOCIETIES AND ACADEMIES . . . . .	458
BOOKS AND PAMPHLETS RECEIVED . . . . .	460

THURSDAY, APRIL 15, 1875

ROYAL AGRICULTURAL SOCIETY'S  
JOURNAL*Journal of the Royal Agricultural Society of England.*  
Nos. 20 and 21 Second Series.

## I.

THE Royal Agricultural Society of England, the greatest Agricultural Society in the world, has on its roll 5,846 members. It was founded upwards of thirty years ago, by men to whom the agricultural classes are largely indebted. It has issued ever since a half-yearly volume of Transactions, in which most valuable papers have appeared from time to time.

We propose to review the two last numbers, 20 and 21: the present notice is confined to No. 20. It contains sixteen papers, which treat of varied and interesting subjects. It begins with a long paper, by Prof. Wrightson, of Cirencester, "On the Agriculture of the Austro-Hungarian Empire," which affords evidence that Mr. Wrightson laboured diligently during a tour in that country, to collect facts. The most important conclusion deduced from his inquiries is that "there is little for the Englishman to learn from Hungarian farming." If consolidation of farms be ever carried to an extreme limit, "a valuable lesson may, however, be taken from that country, where it is no uncommon thing to see hundreds of thousands of acres under a central management." But it is not likely that farming will ever be practised in England on that gigantic scale.

The most readable paper in the journal is a biographical sketch of the late Sir Harry S. M. Thompson, Bart., of Kirby Hall, Yorkshire, whose lamented death, last year, left a blank in the ranks of the Society not easily filled: This notice has been contributed by Earl Cathcart; and it affords ample evidence that his lordship is a man of ability, a good writer, and a man of fine feelings and disposition. The late Sir Harry Thompson, Bart., better known as Mr. Thompson, was one of the most active members of the Society. Speaking from a slender personal acquaintance, we would say that he was a man of great industry and of remarkable capacity for business. He sought to probe every subject to the bottom. He had one quality, which is one of the best a public man could possess—he was true to his convictions. It is generally considered that in filling up important offices in the Society he committed grave mistakes; but believing himself to be right, he urged his views with his usual ability, and with that strong will which enabled him to conquer many difficulties, and won. We commend to the careful perusal of the landed gentry who aspire to take a leading part in agricultural progress, Lord Cathcart's biographical notice, in which they will find the outlines of a splendid career, told with singular truthfulness and felicity.

The contributors to this Journal may be divided into two classes—amateur and professional. Lord Cathcart belongs to the former class, and so does Mr. J. Dent Dent, of Ribston Hall, Wetherby, who contributes an admirable paper under the modest title of "Agricultural Jottings from the General Report of the last Census of

England and Wales." It is rather behind time, but is throughout a candid and thoughtful paper. "On the whole," concludes Mr. Dent, "the number of small holdings is more considerable than was imagined, the demands of the towns are not beyond the means of supply, and the condition of the agricultural labourer is fast rising to a more equal rank with that of the skilled artisan." According to the returns consolidation would appear to have reached the climax in England. The numbers who are described in the returns for 1851, 1861, and 1871 as farmers and graziers are as follows:—

1851	...	...	249,431
1861	...	...	249,735
1871	...	...	249,907

Independently of these, there is a vast number of holders of small pieces of land. The census returns do not furnish the exact figures; but by another official inquiry, returns of live stock were obtained from 469,444 occupiers of land in England and Wales in 1871, a number which was increased to 481,412 in 1873. It may be assumed that the number of farmers and graziers accounted for in the census of 1871 devote their whole time to these pursuits; and that agricultural labourers, tradesmen, artisans, and others, who occupy small holdings, make up the remainder of those who furnished returns of live stock. But until the fact was revealed by these statistics, the public was not prepared for the announcement made by the enumerators that in "England there are about 350,000 separate holdings, not one of which exceeds five acres in extent, and that this number is exclusive of the gardens attached to all classes of dwelling-houses, including those of labouring men."

It is strange that in the face of these facts the leading organ of public opinion has recently laboured to show that small farmers are rapidly dying out.

Professional writers appear in great force in this number of the Journal. Dr. Voelcker, F.R.S., consulting chemist to the Society, contributes two papers; Mr. Carruthers, F.R.S., consulting botanist, contributes an original paper and a translation; Mr. Jenkins, F.G.S., secretary to the Society, contributes a paper on the cultivation of potatoes, with special reference to the potato disease, which was pretty certain to be eagerly perused by all the members of the Society; Prof. Simonds, Principal of the Royal Veterinary College, contributes a report on the health of farm animals; and Prof. Brown, V.S., principal inspector of the Veterinary Department, gives us a paper "On inoculation with the virus of contagious pleuro-pneumonia of the ox."

It is no light duty to review these papers. With us it is not a voluntary task; and this must be our apology for any criticism which may appear severe. Prof. Brown treats of a subject which has attracted a good deal of attention. Prof. Simonds, some years ago, condemned the practice of inoculation as a means of preventing pleuro-pneumonia. Prof. Gamgee has since often repeated his entire belief in it. Prof. Brown, with that caution which has characterised him, has been regarding it as an open question. He has written much on contagious diseases; but he has rarely been able to arrive at any settled views. His present contribution is no exception. In one page we are told "science offers no evidence in favour of inoculation as a preventive of pleuro-pneumonia." Then,

may we not ask, why does a scientific man occupy time and attention in experimenting on it? The experiments recorded in this Journal were made with "the exudate from the lungs of animals which had been slaughtered on account of pleuro-pneumonia." It was assumed that the virus of the disease was present in this exudate. We should like to know on what evidence this assumption is based. We believe that the virus of the disease is given out in the breath, and is not found in any of the secretions; and that none remains, or can be generated in the system, after death. We have deduced this conclusion from our own experiments; and, according to our interpretation, the experiments upon which Prof. Brown's paper is based support the same view. Every competent authority now believes that the virus of contagious pleuro-pneumonia is communicated by a living diseased to a living healthy animal. If the virus could be communicated in any other way into the respiratory passages, there is every reason for thinking that the disease would be produced. If the virus got even into the blood, there is no known reason for thinking that it would not reach the lungs and produce the disease. When the Professor states that he failed to produce the disease with the exudate from diseased lungs, there is some ground for doubting that the exudate contained the virus, and that the title of his paper—"Observations on inoculation with the virus of contagious pleuro-pneumonia"—is questionable, to say the least of it.

We have next to notice Dr. Voelcker's paper entitled "Field Experiments on Pasture Land." We begin by remarking that it is more like the production of a tyro than of a man of well-earned reputation. Some eight or nine years ago Dr. Voelcker suggested to his former pupils and others a series of experiments for testing the efficacy of different manures. In the paper to which we invite attention, the result of one series of these experiments is given. Dr. Voelcker did not superintend any of these experiments. They were made in different parts of the country, by men who, we presume, possess more than average fitness for describing their own experiments. It is most desirable that experiments of this kind should be carried out on different soils and in different circumstances; and, so far, the scheme set on foot by Dr. Voelcker deserves our highest praise. It is to the execution of the scheme, and to his own report in particular, that we object. The experiments were made at four different places. We are not furnished with the analysis of the soil at any of these places. Among the manures experimented with were mineral superphosphates, Peruvian guano, crude potash salts, bone-dust, &c. It is notorious that superphosphate varies greatly in composition. It is equally well known that of late years Peruvian guano has varied greatly in quality. No man knows this better than Dr. Voelcker, and yet in the report under review he does not give the analysis of a single manure used in these experiments. Under these circumstances we submit that false conclusions are liable to be deduced from the results. This sort of work is not science, and we call upon the governing body of the Royal Agricultural Society of England to put an end to it. When we examine with care the tables and the conclusions sought to be drawn from them by Dr. Voelcker, we see additional grounds for offering this suggestion. Every farmer of experience

knows that the quality of the soil varies exceedingly, not only on the same farm, but in different parts of the same field. Experimental ground should, therefore, be treated with the greatest care. In most cases it will be necessary to prepare it in a variety of ways. The writer has a piece of ground under experiment which he manipulated with the utmost care. It was dug to a uniform depth, inequalities of surface and of soil removed by levelling and mixing, and repeated crops of grain raised without any manure before any experiment was made. No such care appears to have been considered necessary in undertaking the experiments on which Dr. Voelcker reports. The tables bear out our view fully, as we shall briefly show. In each place ten plots were laid out for experiment, and two of the ten (Nos. 5 and 10) were left unmanured. In page 431 we are favoured with the result of one set of these experiments, and we take from it the following figures:—

Plot.	Manure.	Yield of grass per acre.			
		Tons.	qrs.	lbs.	
5	No manure ... ..	...	4	2	1
8	Crude potash salts ... ..	...	3	3	6
10	No manure ... ..	...	3	3	26

Dr. Voelcker concludes from these figures that crude potash salts diminished the produce. Now, in looking at the figures we find a greater difference between the two unmanured plots than between the one to which potash was applied and either of the others. Assuming that this difference arose from difference of soil, what guarantee have we that the crude potash salts were not applied to a soil inferior to either of the two unmanured plots?

We take another illustration of our argument from the table, page 432:—

Plot.	Manure.	Weight of grass per acre.			
		Tons.	cwt.	lbs.	
3	Fine bone-dust ... ..	...	4	13	0
4	Mineral superphosphates and crude potash salts ... ..	...	3	19	4
5	No manure ... ..	...	2	17	2
6	Common salt ... ..	...	3	18	2
8	Crude potash salts ... ..	...	5	4	0
10	No manure ... ..	...	4	0	4

Here we have the difference between the two unmanured plots greater than the difference between one of them (No. 10) and any of the manures named.

The weight of grass from common salt was more than that from one of the unmanured plots, and less than that from the other. On which are we to rely in coming to a conclusion as to the action of common salt on the land of the experimenter? And, again, are we to conclude that while bone-dust increased the produce above either of the unmanured plots, and while crude potash salts increased it still higher, a mixture composed of superphosphate and crude potash salts produced less than an unmanured plot?

#### COOKE'S "FUNGI"

*Fungi: their Nature, Influence, and Uses.* By M. C. Cooke, M.A., LL.D. Edited by the Rev. M. J. Berkeley, M.A., F.L.S.—The International Scientific Series, vol. xiv. (London: Henry S. King and Co., 1875.)

THE names both of Dr. Cooke and Mr. Berkeley appear on the title-page of this work, but in the editor's preface it is stated that the whole of the manu-



script was prepared by Dr. Cooke. There is very much that is interesting in this volume, but upon the whole the book is a disappointing one. The editor states that the work is intended for students, but we fear that the junior student will be repelled rather than attracted by the hosts of scientific names of genera and species which crowd many of the pages with italics. Then we cannot but condemn the mode of arrangement of the contents.

The mode of division of the work renders it quite impossible for the reader to obtain any connected account of the life-history of one single species. This we consider a very grave defect indeed. To trace the life-history of one form we may have to refer to the chapters on the "Structure," "Germination and Growth," "Sexual Reproduction," and "Polymorphism" before we can obtain what we want. This ought not to be, and we venture to think Dr. Cooke would have rendered his book much more useful if he had given connected life-histories of the most interesting and best known forms.

Some of the omissions have rather surprised us. For example, we do not find any account of the yeast plant, a form which most students of biology will do well to study carefully. The rather meagre index does not contain the words "Yeast," "Torula," "Hormiscium," or "Saccharomyces," although the word "yeast" occurs in the first chapter. Then there is no account of the life-history of the ergot of rye. Its life-history is perfectly well known, and most students, whether medical or not, ought to have some knowledge of it.

The book is evidently the work of a systematic rather than a morphological botanist, and this may account for some of the errors that have been made. For example, the process of conjugation and formation of zygospores in the Mucor is quite correctly described, but in what way can Dr. Cooke apply the term conjugation to the fertilisation of the oogonium by the antheridium in *Achlya* and *Peronospora* as figured on pages 169 and 171? The formation of the ascogonium of *Eurotium Aspergillus-glaucus* is only slightly indicated on p. 189, while the pollinidium is altogether omitted. The classification is that given in Cooke's "Handbook," but, for the use of the student, we do not think it equal to that given in Grisebach and Reinke's translation of Oersted's "System der Pilze," &c.

The Lichen-theory also receives a share of attention; Schwendener and his followers are condemned for the "sensational romance of lichenology," as it has been called. Truth, however, is often stranger than fiction; and if anyone would take the commonest lichen he can find and give botanists a complete account of its life-history, he would earn the gratitude not only of all algologists, fungologists, and lichenologists, but of botanists generally.

The chapters on the "Uses," "Notable Phenomena," "Influences and Effects," "Habitats," "Cultivation," "Geographical Distribution," and "Collection and Preservation," are very valuable; and if the other chapters had been run together into connected life-histories, we think the work would have been an admirable one. As it is, it cannot fail to interest and instruct, and every page bears evidence of the extensive and accurate knowledge of the author. The freedom from errors of the press in the names of the fungi shows the care with which the

work has been revised and edited. The illustrations are numerous and good, but there are a few old faces among them whose absence would not have greatly grieved us.

MM. H. AND E. MILNE-EDWARDS'S NEW  
WORK ON MAMMALS

*Recherches pour servir à l'histoire naturelle des Mammifères comprenant des considérations sur la classification de ces animaux*: par M. H. Milne-Edwards; *des observations sur l'hippopotame de Siberia et des études sur la Faune de la Chine et du Tibet Oriental*: par M. Alphonse Milne-Edwards. Two vols. 4to., text and plates. (Paris: G. Masson, 1868-74.)

LAST year we called our readers' attention to the zoological researches lately made in the Sino-Chinese province of Moupin, by the French traveller, Armand David,\* and to the particular importance of his discoveries in the class of Mammals. The work now before us gives a complete account of the many new forms the knowledge of which we owe to the energy of this excellent traveller and naturalist, besides other important contributions to the history of the same class of animals.

The work commences with an essay by the veteran zoologist, M. H. Milne-Edwards, upon the general classification of Mammals. The system here propounded, which has many good points, and embraces details already put forward by the author in previous writings, is not one that we think will meet with very general approval. Its chief feature is the elevation of the marine or pisciform Mammals (containing the two orders of Sirenians and Cetaceans) to a second sub-class equivalent in value to the normal Mammals on the one hand and to the Marsupials on the other, and the degradation of the Monotremes to a mere subdivision of the latter. Prof. Huxley's views as to the relative position of these groups, not to speak of his general arrangement of the class, appear to us to be much more easily justifiable.

The main body of the work consists of three memoirs by M. Alphonse Milne-Edwards, a worthy son of his distinguished father, illustrated by a long series of well-executed plates, which constitute the second volume. The first of these memoirs contains observations upon the hippopotamus of Liberia—a smaller form of the animal now so well known to us from the exhibition of living specimens in the Zoological Society's Gardens, and in other collections. First described in America in 1844, the smaller hippopotamus remained entirely unknown in Europe until within the last few years, when specimens were procured for the Jardin des Plantes by the exertions of Prince Napoleon when Minister of the Colonies. The figure now given by M. Milne-Edwards is the first that has been published of the entire animal, and the general skeleton is likewise now for the first time described, only the cranium having been known to the American naturalists.

M. Alphonse Milne-Edwards's second essay is entitled "Études pour servir à l'histoire de la Faune Mammalogique de la Chine," and is based upon collections trans-

\* NATURE, vol. x. p. 32 (May 14, 1874)

mitted from the North of China by M. de Montigny, M. Fontanier, and M. l'Abbé Armand David, especially those of the last-named traveller, who devoted several years to zoological researches in the country north of Peking, and in the distant parts of Mongolia. The series of Mammals here treated of is of especial interest as supplementing the discoveries recently made by Russian naturalists in Central and Eastern Siberia. The forms are chiefly those characteristic of the steppe-regions of the great northern continent of the Old World, such as *Siphneus*, *Cricetus*, *Dipus*, and *Spermophilus*. A full account is also given of the deer of this district, as also of the larger and smaller cats. Amongst the latter are enumerated the Ounce (*Felis irbis*), of which examples were obtained by M. Fontanier, and two species described and figured as new, under the names *Felis microtis* and *F. tristis*. Lastly, M. Milne-Edwards records the existence in the mountains situated in the east of the province of Tchê-li (as testified by M. Fontanier) of a singular species of ape of the genus *Macacus*, which he designates *M. tcheliensis*. Considering that the province of Tchê-li is nearly on the same isothermal line as Paris, the discovery of this animal is not a little remarkable.

The concluding essay of the volume relates to a still more novel mammal fauna than that of Peking. Among the Yung-Ling Mountains, in the far interior of China, lies the little-known principality of Moupin, which we have already alluded to. Here the Abbé David, after a stay of several years in Northern China, established himself for a year in one of the large valleys at an elevation of about 6,000 feet above the sea-level, and in the midst of peaks ranging up to above 15,000 feet of altitude. Of the wonderful discoveries which he here made we have already learnt something from the preliminary notices of M. Alphonse Milne-Edwards on this subject. In the present memoir, detailed accounts are given of the many strange forms of which specimens were obtained by M. David in this district. Excellent illustrations, not only of the entire animal, but also of its characteristic parts, add greatly to the value of the descriptions, and we now become acquainted for the first time with the singular appearance of *Rhinopithecus roxellana*, a long-haired monkey with a "tip-tilted" nose, which inhabits the mountain-forests of Moupin; with *Nectogale elegans*, a new aquatic insectivore of the same district; with *Scaptonyx*, a new genus of the Mole family, from the confines of Setchuen; and with *Ailuropus melanoleucus*, from the inaccessible mountains of Eastern Tibet.

The last-named animal, which in external appearance presents some resemblance to a large white bear with a black band across the back, is most nearly allied to the Panda (*Ailuurus*) of the Himalayas, and belongs to the same peculiar family of Carnivores. Besides these, we have an account of *Elaphodus*, a new genus of ruminants, belonging to the Deer family, but with very diminutive horns; and of many other new and interesting Mammals, which show that the fauna of this part of Tibet is in many respects akin to that of the southern slope of the Himalayas. On the whole, we think there can be no question that the present work is one of the most important contributions that has lately been made to zoological science, and reflects the greatest credit upon its accomplished authors.

#### OUR BOOK SHELF

*An Introduction to Human Anatomy.* By William Turner, M.D. (Edinburgh: Adam and Charles Black, 1875.)

PROF. TURNER having written the article "Anatomy" in the first volume, recently published, of the ninth edition of the "Encyclopædia Britannica," has, at the suggestion of the publishers, reproduced it in a separate form, the first half of which we have received as a compact volume of some 400 pages.

This part contains an account of the skeleton, joints, muscles, nervous system, and organs of special sense, together with a chapter on the minute anatomy of the different tissues of the human body. The descriptions are short and make no pretensions to extreme minuteness, as may be judged from the following reference to the atlas:—"The first (vertebra) or *atlas*, has no body or spine: its ring is very large, and on each side of the ring is a thick mass of bone, the *lateral mass*, by which it articulates with the occipital bone above and the second vertebra below." In the account of the muscles also the space devoted to each is frequently little more than that required for the mention of the name:—"The supinator and pronator muscles (of the fore-arm) are all inserted into the radius; the supinators are the supinator longus, supinator brevis, and the biceps; the pronators are the pronator teres and the pronator quadratus." The nervous system has received more attention, and the general description of the brain, together with that of its more intimate structure, is fairly full. The author's valuable observations on the cerebral convolutions, together with his investigations on the relation of these to the walls of the bony cranium and the sutures, receive their due share of notice, and are here collected together for the first time. The chapter on the organs of special sense are also well worthy of study. In the histology we cannot help thinking that almost too much credit is given to a young and promising microscopist, some of whose results are still, however, decidedly *sub judice*.

We find it difficult to decide mentally to what class of students the book before us will be of most value. To the ordinary medical student who has but a couple of years in which to fully master the subject of human anatomy, the detail will not be sufficient, and one of the text-books will be more useful. To the amateur reader there is a mass of technical terms which he will have to attempt to wade through, almost certainly without success, both on account of their number and, to him, their meaninglessness. To the special investigator of the anatomy of the nervous centres the chapter devoted to that subject will be extremely valuable, as the whole work will be to the advanced student who desires to take a rapid last glance through his subject before competing for a high examination place.

#### LETTERS TO THE EDITOR

[The Editor does not hold himself responsible for opinions expressed by his correspondents. Neither can he undertake to return, or to correspond with the writers of, rejected manuscripts. No notice is taken of anonymous communications.]

##### On the "Law of Fatigue" regulating Muscular Exertion

IN NATURE, vol. xi. pp. 256 and 276, Mr. Frank E. Nipher, of the University of Iowa, has published some interesting observations bearing on the "Law of Fatigue" which regulates muscular exertion, and criticises the use which I have made of some experiments published by him, one series of which seemed to me to be highly confirmatory of the "Law of Fatigue" which I had previously established on the basis of other experiments carefully made, and quite different in principle.

The "Law of Fatigue" is thus stated by me in "Principles of Animal Mechanics," p. 442:—"Law III. When the same muscle (or group of muscles) is kept in constant action until fatigue sets

in, the total work done multiplied by the rate of work is constant." The words *constant action* are here to be understood in the sense in which all muscular action used by animals is constant, viz., short periods of contraction followed by short intervals of rest, as in walking, climbing, &c. And the velocities employed are understood to be, within certain limits, such as are used in all descriptions of labour.

The "Law of Fatigue" (thus stated) is based by me upon several and various classes of experiments.

Mr. Nipher's experiments (employed in my book, pp. 462-65) consisted in raising various weights at a fixed rate and at regular intervals through a fixed height, as described in page 462 of my book. The "Law of Fatigue" in this case led me to the formula—

$$n(w + a)^2 = A \tag{1}$$

which is a cubical hyperbola.

As stated in NATURE by Mr. Nipher, the comparison of this formula with observation is given in pp. 464-65, and is most complete and satisfactory. I here give it for the right arm, and refer for that of the left arm (which is equally satisfactory) to the book itself.

Mr. Nipher—Right Arm (raising weights at constant rate).

w	n (obs.)	n (calc.) from (1)	Diff.	Diff. percent.
1 kil.	255	250	+ 5'0	+ 1'9
2 "	97	111	- 14'0	- 14'5
3 "	61	62'5	- 1'5	- 2'4
4 "	37'7	39'9	- 2'2	- 5'8
5 "	29'3	27'8	+ 1'5	+ 5'1
6 "	21'5	20'4	+ 1'1	+ 5'1
7 "	15'8	15'6	+ 0'2	+ 1'2
8 "	12'8	12'4	+ 0'4	+ 3'1

$$A = 1,000^6$$

$$a = 1$$

Mr. Nipher admits (NATURE, vol. xi, p. 257) that this comparison of his observations with formula (1) deduced from the "Law of Fatigue" is satisfactory, but proposes (NATURE, vol. xi, p. 276) to substitute for his observations used by me, another set of similar observations submitted to a series of reductions;

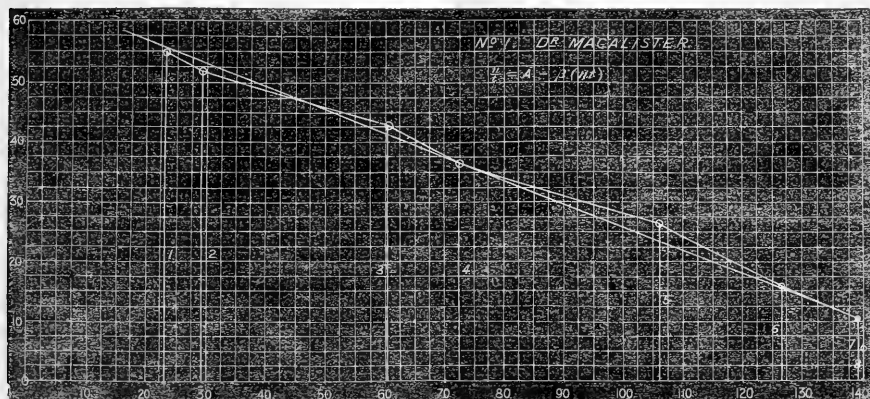

these observations are given in his Table II., and will be fully considered by me hereafter. I may here observe that the percentage error in the above table is less than that given by him in comparing Table II. with an empirical formula.

Other experiments, in which the same weight was lifted at varying rates, were made by Dr. Alexander Macalister, Mr. Gilbert Haughton, and by Mr. Nipher (*vide* "Animal Mechanics," pp. 468 to 477). Mr. Nipher now rejects his own experiments, and, as I believe, with good reason. These experiments are given in NATURE, vol. xi, p. 256, Table I., with the exception of the first line, which is taken from the experiments just given. The reason why I transferred the first experiment from the former series is this. The column for *n* ought to show a maximum in passing from very rapid to very slow motions; for if the motions be very rapid, respiratory distress sets in, and the work done will be less than with a slower motion; and if the motion be very slow, the useful work done will be also less, owing to the fatigue work spent in holding up the weight; from this it follows that there is a certain rate of lift at which the maximum work is done.

If we omit the first line in Mr. Nipher's experiments, Table I., we find no trace of a maximum in the column for *n*, which may be regarded as internal evidence of something wrong in the observations. At the time of publishing my book, I thought (and still think) that Dr. Macalister's and Mr. Gilbert Haughton's experiments were better than those of Mr. Nipher, of which, however, I made use as well as of the other experiments, as I wished to employ all the materials at my disposal in discussing the Law of Fatigue. I now fully concur with Mr. Nipher's estimate of the value of his observations, made at vary-

ing rates, which he states "were merely published as a preliminary" (NATURE, vol. xi, p. 256, note).

The withdrawal of Mr. Nipher's experiments at varying rate from the controversy disposes at once of the greater part of the criticisms, which are based on the difference between his experiments at varying rate and at fixed rate.

Mr. Nipher, however, not only withdraws his experiments at varying rate, but criticises Dr. Macalister's and Mr. Gilbert Haughton's experiments of the same class.

I shall first answer his criticisms on the experiments of Dr. Macalister and Mr. Gilbert Haughton, and then notice his own new experiments at fixed rate and empirical formula.

The relation between *n* and *t* in Dr. Macalister's and Mr. Gilbert Haughton's experiments is represented by a central cubic, viz. :—

$$n = \frac{At}{1 + \beta t^2} \tag{2}$$

This formula is plotted and compared with the experiments in Diagrams, pp. 472 to 474, and the agreement is evidently close. Mr. Nipher transforms equation (2) into the following :—

$$\frac{n}{t} = A - \beta nt, \tag{3}$$

and adds :—"Anyone who will take the trouble to calculate and co-ordinate the values of  $\frac{n}{t}$  and *nt* from Prof. Haughton's ob-

\* If we correct these values by the method of least squares, we find *A* = 1033, *a* = 1'004, and may reduce the sum of the squares of the percentage differences from 316'33 to 242'56, thus making the agreement between theory and observation somewhat closer.

servations, pp. 468-474, will see that these co-ordinated values form a curve instead of a straight line."

I felt much surprise at reading this statement, because if the observations agree with the central cubic (2), they must agree with any transformation of equation (2).

I now give the values of  $\frac{n}{t}$  and diagrams, comparing them with equation (3), an inspection of which will show that Mr. Nipher is in error in saying "that these co-ordinated values form a curve instead of a straight line." Anyone accustomed to such observations will see that they do *not* form a curve, but deviate *irregularly* as all observations do, above and below the "straight line," which is the true "curve" that represents them.

No. 1.—Dr. Macalister's Experiments ("Animal Mechanics," p. 468).

No.	$nt$	$\frac{n}{t}$
1	23'40	55'4
2	29'25	52'1
3	60'18	43'2
4	72'38	36'9
5	106'00	26'5
6	126'38	15'6
7	139'10	10'2
8	139'97	5'4

The accompanying diagram (No. 1) shows these values plotted, and the right line which represents them all except No. 8, which falls too much below the line.

No. 2.—Mr. Gilbert Haughton's Experiments (p. 474).

No.	$nt$	$\frac{n}{t}$
1	6'89	21'5
2	25'58	18'1
3	44'94	9'8
4	51'00	5'7
5	61'20	1'7

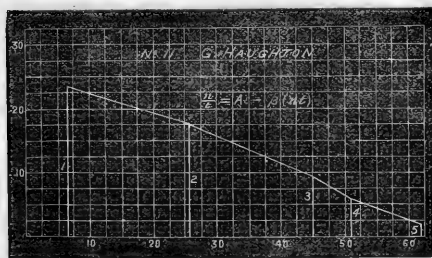

The accompanying diagram (No. 2) shows that these observations also may fairly be represented by a straight line.

Trinity College, Dublin, SAMUEL HAUGHTON  
March 13

(To be continued.)

### The "Wolf" in the Violoncello

As the question asked by Mr. Fryer in your issue of the 25th of March (p. 406) remains unanswered, allow me to suggest what has been brought prominently before me in some recent experiments.

The "wolf" of which he speaks occurs in all instruments of the violin family, and not only in the violoncello; indeed, it is present even in fine specimens by the great masters. It is perfectly true that it depends on the resonant case of the instrument itself, as can easily be shown in the way he suggests; a "false string" is soon detected and remedied by any player.

No doubt it indicates that the consonating box has the power of reinforcing certain vibrations, but not others; and even of stifling some by interference. Curious facts on this topic have recently been brought before a foreign scientific society, which show that the acquired power of consonance depends on a molecular change in the material of which the instrument is made, that it can be increased by steady and good playing, that it is to be detected even in brass instruments like the trumpet. It has long been known that a violin deteriorates in the hands of a bad performer. But there is an obvious cause of weakness in all fiddles which seems to me to have hardly attracted sufficient attention; I mean the two "sound-holes" in the belly. These *f*-shaped apertures, which are doubtless needful to allow escape of aerial vibrations, cut the grain of the wood completely across in a most important part. Every connoisseur pays particular attention to the straightness and regularity of grain; indeed, blocks of wood well matched in this respect, from which two similar sides might be cut, have been handed down in workshops as of inestimable value. Wheatstone's well-known experiment of the Telephonic Concert proves how perfectly musical tones can be conveyed along the fibres of pine-wood to a considerable distance. These considerations led me recently to submit the point to the test of trial. What I have elsewhere termed "elliptical tension bars" are simply four longitudinal struts of light pine glued to the back of the belly, intercepting the sound-holes. They have the effect of removing the "wolf;" sometimes entirely, nearly always to a marked extent. No doubt they also act by strengthening the fabric exactly in the line in which the string pulls. The pull, which is considerable even in a state of rest, increases enormously when it is moved slightly out of its position of quiescence, for well-known mechanical reasons; and hence, besides the removal of the "wolf," there is gained by means of the bars a decided increase of power and tone.

The "elliptical" form was adopted because it is found to give considerable resistance with small amounts of material. Anything which rendered the belly of the fiddle heavy would perform the function of the "mute" as now commonly applied to the bridge, but which can be, and often is, replaced by a penny or a half-crown wedged between the strings below the said bridge. The great rigidity and low specific gravity of dry pine-wood meet the two requirements: the whole mass added does not exceed twenty or thirty grains.

Musicians are slow to adopt theoretical improvements, and dealers in violins cannot be expected to favour anything which puts a one and-ninepenny fiddle more nearly on a level with a Stradivarius than it was; but I am honestly of opinion that the system is of value. I must, however, protest against its being prejudiced by the unsuccess of imitators or of previous efforts. Something of the sort has often been tried before, and it was only after long and laborious experiment that this particular attempt gave good results. By these, and in due time, I am content to let it be judged.

14, Dean's Yard

W. H. STONE

### Flowering of the Hazel

THE question whether the male and female flowers of the hazel mature simultaneously on the same bush has been already discussed in your columns (NATURE, vol. i. p. 583, vol. iii. pp. 347, 509). A repetition of the observations this spring has enabled me to confirm my previous statement that this is the case, at all events very frequently; in fact, almost invariably in all the cases that have come under my notice. As this is in direct opposition to the statements of several of your correspondents, especially one resident in Kentucky, who affirms that the hazel, though apparently monoecious, is practically dioecious, it would be interesting if we had further information as to the circumstances under which these varying conditions occur. On the present occasion the male and female flowers were found in close contiguity and both in a mature condition at the close of a remarkably protracted cold and dry season, at an unusually late period, the last week in March.

ALFRED W. BENNETT

### A Flint Celt

ON Tuesday last, the 6th inst., I found on the west shore of this bay a very fine specimen of a flint celt, quite perfect. The cliff in the immediate vicinity is composed of fluviatile clays, capped with a thin bed of Bembridge limestone, in a very broken state: the vegetable soil resting on the latter is only from five to ten inches deep. Perhaps it may interest some of your readers if you do me the favour to notice this. It is rather remarkable

that the spot on which the celt was found should be within thirty yards of the site of a Roman building discovered by me in 1864. Gurnet Bay, April 9  
E. J. A' COURT SMITH

### Arctic Temperatures

In your article on the Austrian Polar Expedition (vol. xl. p. 397), it is stated that in January "the warm S. and S.W. winds always brought great masses of snow, and produced a rise in the temperature amounting to 30°-35° R. in a few hours." 32 R. = 72 F.

Such enormous fluctuations of temperature are unparalleled in any other part of the world, and it seems quite impossible that they can be due to any drift of warm air. I would suggest that they are probably caused by the wind tearing up the frozen surface of the sea, and liberating the heat of the unfrozen water below. Dr. Kane, when wintering in Smith Sound, once met with such a rise of temperature, and he says that open water was near. This explanation of the phenomenon is supported by the fact you mention in the same article, page 398, that in the summer the temperature was remarkably constant. The same cause could not act during summer, for the air is not then much colder than the unfrozen water.

There is no doubt of the power of a storm of wind to tear up a very thick sheet of ice.

JOSEPH JOHN MURPHY

Old Forge, Dunmurry, Co. Antrim, March 30

### AÉRONAUTICS

M. GASTON TISSANDIER has just finished the analysis of carbonic acid contained in the air collected during his recent ascent (vol. xi. p. 429). He found at Paris 37 cubic centimetres per 100,000; at a height of 2,700 feet, 27; and at a level of 3,300 feet, 30. The difference of altitude between the two aerial stations being too small to justify drawing any conclusions he will shortly make another ascent with the same balloon to an altitude of 24,000 feet.

M. Godard made an ascent in the balloon *Saturn*, from Bayonne, on March 29, at half-past five, and was drifted over the Pyrenees. The trip was difficult, as the balloon was loaded with snow and hail, and all the ballast was thrown over in order to keep the balloon afloat. The cold was intense, and the wind very strong. The landing took place at Azul Mayor, a small country town east of Pampeluna, at half-past seven, the distance run being 120 kilometres. The grapnel having been broken, the aeronaut and the three passengers were severely hurt. This is the first time that any balloon has crossed the Pyrenees. The *Saturn* followed the French valley of the Nive and the Spanish valley of Baztan on the southern side. An interesting observation was made when crossing the culminating point of the pass. The Larratée Neguya was surrounded by cirro-cumulus, which resisted the force of the wind and seemed an obstruction in the way of aeronauts, who found it necessary to throw out a certain quantity of ballast, and to reach an altitude of 6,600 feet, in order to cross that sea of motionless clouds. A strong hissing noise was heard when travelling over them; whether it was produced by the friction of the air on the peaks or on the masses of electrified vapours, can only be decided by another experiment conducted scientifically.

On April 4 two ascents were made almost simultaneously. M. Triquet ascended from the Place du Trône, Paris, and landed at Montreuil, 20 kilometers from his starting-point, forty minutes afterwards, having run in an E.S.E. direction. M. Durouf ascended from Cahors, in the Lot, and landed at Catres, in the same department, having run 22 kilometers in sixty-five minutes, but in a N.N.W. direction. Both balloons having ascended at the same moment, moved at right angles.

I have reason to believe that a number of ascents will

be made simultaneously from La Villette gasworks, and the several tracks compared with each other. Some interesting facts may be elicited by these comparative trips.  
W. DE FONVIELLE

### ARCTIC GEOLOGY\*

#### II.

*Cryolite of West Greenland Coast.*—At Evigtok (*Fvik*, Eng. grass), twelve miles from Arksut (Eng. leeward), in 61° 13' lat. and 48° 9' W. long., the mountains rise to a height of more than 2,000 feet, enclosing a sort of basin, with an area of more than a square mile, the bottom of which is covered with grass and *Salix arctica*, four feet in height, and other plants. This is much frequented in summer by the Greenlanders, who catch large numbers of capelins and cod, which frequent the coast in shoals, as well as the *Salmo arcticus*, Linn. (the *Lodde* of the Norwegians). Weights used in this fishery, taken by Danish missionaries to Copenhagen at the beginning of the century, were found to be composed of cryolite, which led to the discovery of two veins of that mineral in the gneiss at the head of the bay, which has since been worked by Mr. Taylor, F.G.S. The white cryolite bed is about eighty feet in width, dipping south with the planes of the gneiss in which it occurs. Near its higher portion there is a large quantity of galena, worked in 1854, which gave 82½ per cent. of argentiferous ore, containing forty-five ounces of silver to the ton of ore. Fifteen feet from the surface the cryolite was of a dark colour, so that it is probable that the black cryolite in the higher vein is merely less decomposed, and not bleached. The Greenlanders value the white variety most, which they call orsoksiksæt (*orsok*, blubber), from its soft greasy appearance and feel; they gradually pound tobacco leaves placed between two pieces of it, the resultant powder consisting of half of cryolite dust, which they consider superior to any European snuff.

Large quantities of cryolite are now imported to Copenhagen, the mines being worked by Messrs. Thomsen, of that city. Mr. Qualey reports that pieces of gneiss and trap are found imbedded in the cryolite, and states that the mines are filled with snow and ice during the winter, work being carried on by fifty men from May to October; 5,000 tons are raised yearly. Cryolite, except at Miask, in Siberia, does not occur out of Greenland.

Cryolite is a fluoride of sodium and aluminium, and is composed, according to Mr. Evan T. Ellis, of—

13	per cent.	of aluminium,
34	"	" sodium,
53	"	" fluorine.

In Denmark, it is largely used in the manufacture of soda, which is procured by mixing it with lime and applying heat, 100 tons of cryolite yielding forty-four of caustic soda. It was introduced into Philadelphia by the Pennsylvania Salt Company, who imported 8,000 tons in 1867. By mixture with silica a very beautiful glass is produced, capable of being moulded. Cryolite was used by Deville as a flux in the manufacture of aluminium, the process of extracting aluminium from it was first used by Mr. Dick in 1856, but its use has since been abandoned in favour of bauxite. The fluoride of calcium is sent to Paris to be used in glass etching.

Associated with the Greenland cryolite brought over

\* Continued from p. 449.

† Gusecke, *Zain. Phil. Jour.* vol. vi. 1822; J. W. Taylor, *Quar. Jour. Geol. Soc.*, 1865; *Chemical News*, 1868, p. 8, &c.; *Proceedings Amer. Pharm. Soc.*, 1868. See Rink's Memoir on Greenland, published by the Royal Danish Academy of Sciences, 1853, p. 71; L. Jacobsen's "Et Aar i Grønland, 1862"; and Lieut. Blahme, in the Danish magazine *Fra alle Lande*, vol. i.

by Mr. Tayler, M. Hagemann found, in 1868, Pachnolite and Columbite, and a mineral he termed Arksutite. Near the cryolite deposits also occur extensive veins of tinstone, covering an area 1,500 feet long by 80 feet broad, running E. and W. and N.E. and S.W., with a width of 10 inches, the tin being 1 inch to 1½, and the gangue felspar or quartz, associated with galena, spathic carbonate of iron, copper and iron pyrites, tantalite taking the place of wolfram, usually associated with tin ores.

*Mid-Greenland.*\*—*Sigillaria* and a fern, probably *Pecopteris*, were discovered by Dr. Pfaff in 1870-71, in erratic blocks, on the coast of Disco; they appear to have been derived from rocks of Carboniferous age, but as none such are now in Greenland, it is most probable, as has been suggested, that they were brought by floating ice from Melville Island.

The Greenland coast and islets are composed of gneiss from 68° 30' to 71° N. lat., with the exception of the projecting peninsula of Noursoak, the north-eastern coast of which, in Omenak Fjord, consists of Cretaceous rocks, in which, however, no calcareous beds have as yet been discovered, and from which the only fossils obtained have been several species of plants, determined by Prof. Heer, including *Pecopteris arctica*, Hr., *P. borealis*, Brong., and eight other ferns, *Zamites arcticus*, Göpp., *Sequoia Reichenbachii*, Gein., *Pinus Peterseni*, and a Monocotyledon, *Fasciulites Grænländicus*, Hr.

The western coast of Noursoak consists of trap, as does also that of the island of Disco, or Kekeratassuak, as far as Lievly or Godhavn, where there is a patch of syenite. The shores of the Waigat Strait, both on the Noursoak and Disco Island side, consist of Miocene beds, which also extend in Disco along the east coast to Godhavn, and are more or less associated with the trap (basalt), which consists entirely, according to Nordenskjöld, of "consolidated beds of ashes and volcanic sand," which by pressure have assumed a crystalline form.

The Cretaceous strata of the north coast of Disco are divided by Nordenskjöld into two series, the lower, or *Kome strata*, and the higher, or *Atane beds*. The former consist of a sedimentary coal-bearing formation filling up old valleys and depressions in the undulating gneiss beds, reaching a thickness of 1,000 feet, lying either horizontally or dipping 20° towards the Noursoak peninsula. It is probable that the plant remains brought home by Giesecke and Rink were from this series, beds at the base associated with the lowest thin coals being so full of leaves as to have become a felted flexible mass, resembling the vegetable parchment produced by the action of sulphuric acid on lignite. Coal is collected by the Greenlanders for their personal household use at Kome, Sarfarik, Patorfik, and Avkrusak. Amongst the plants from Kome are the beautiful Cycads *Zamites arcticus*, *Glossosiamites Hoheneggeri*, and several plants stated by Heer to occur in the Ürgonian strata of Wernsdorff.

On the gneiss of Karsok River, at 840 feet above the sea, occur sedimentary strata, basalt, and gravel, which continue to 1,150 feet up the slope, where a gravel with angular pieces of graphite occurs, near a sandstone with coal; the graphite is stated by Capt. Brockdorff, who took five tons to Europe in 1850, to form a horizontal bed eight to ten inches thick, covered with clay, sand, and sandstone. As the beds lie horizontal, and are 300 feet above the Cretaceous rocks, the graphite must be of Cretaceous or still more recent age. Graphite also occurs at Niakornet. An analysis of the Karsok graphite, by Dr. Nordström, gave carbon 95.68, hydrogen 0.22, and ash 3.60; the latter gave 50 per cent. of silica.

Graphite also occurs further north, at Uppernivik, near Sanderson's Hope, in fine-grained granite, consisting of grey quartz and felspar of a waxy lustre, with garnets one inch in diameter.

\* The Danish Government divides the coast into a North and South Inspectorate, the former commencing at lat. 66°, and extending to 73° N. beyond which they do not maintain a monopoly of the trade.

The Atane strata occur on the southern side of the Noursoak peninsula, between Atanekerdruk and Atane (Nordenskjöld); the thick coal of Atane, that at 750 feet above the sea at Kome, the Ritenbenk coal-mine at Kudlisset, the retinite beds of Hare Island, all probably belong to this portion of the series. Dicotyledonous leaves occur, one being near to *Magnolia alternans*, Heer, from Upper Cretaceous of Nebraska; these do not occur in the lower measures, and point to a "limit plant fauna" occurring in the Arctic Cretaceous beds, corresponding to that found in the European Gault, in which dicotyledonous plants first appear in Europe.

Two analyses have been made of the coals from Disco, but whether of Cretaceous or Miocene age I do not know; one by Prof. Fyfe,\* of Aberdeen, the other by Mr. Keates, of London †:—

	Keates.	Fyfe.
Sp. gravity ... ..	1.369	1.384
Gaseous or vol. matter ...	44.45	50.60
Moisture ... ..	75	—
Sulphur ... ..	55	—
Coke { Fixed carbon ... ..	47.75	37.86
{ Ash ... ..	5.50	9.54
	100.00	100.00

The lignite contains a trace of bitumen, but the coke is non-caking and useless.

*Miocene Rocks.*—Sir Charles Giesecke, F.R.S., describing Disco Island in 1821,† gives the following section of Ounartosak Mountain, near Godhavn:—

1. Basalt, columns with three to seven sides, more or less magnetic.
2. Reddish-brown ferruginous clay.
3. Amorphous basalt, with geodes of mesotite, &c.
4. Reddish-brown ferruginous clay.
5. Reddish-brown wacke, with stilbite, mesotite, &c.
6. Trap Tuff.
- 6a. Basalt Tuff, with geodes of crystallised apophyllite with mesotite or earthy zeolite.
7. Granite, with garnets.

The trap (basalt) rocks lie tolerably flat, and range S.W. to N.E., resting on gneiss. Sandstones occur at Aukpadlartok, and thence to Aumarurtikset, where coal seams occur, one of which is 9 feet in thickness, the section being:—1. Sandstone with pyrites; 2. Brown coal; 3. Schistose sandstone; 4. Pitch coal; 5. Argillaceous schist; 6. Brown coal; 7. Sandstone with plants.

From the granite (gneiss?) of the islands on the south side of Disco, Giesecke records tinstone, magnetic pyrites, epidote, and diallage, and states that the Disco mesotite was found by Sir David Brewster to vary much from that of Auvergne; and he describes the occurrence of rounded boulders of primitive rocks at the tops of the highest mountains near the coast. Giesecke's collections were destroyed in the bombardment of Copenhagen, whilst he went to Greenland in the Danish service, and the collections he made in that country were captured by English cruisers and sold by auction at Leith, where they were purchased by Mr. Allan, who distributed the duplicate specimens of Greenland cryolite, sodalite, and allanite, at that time of great rarity, over Britain.

At Atanekerdruk, Nordenskjöld describes Miocene clays with vast numbers of plant impressions, at 1,000 to 1,200 feet above the sea, and newer than the Atane beds, the base of the Miocene beneath the clay being soft sandstone and sand; the strike of the strata corresponds to that of the strait, and the dip is 8-32° to E.N.E. It formerly extended across the strait, and forms sandhills 2,000 to 3,000 feet in height along the eastern shore of Disco, horizontal thin coal-bands and erect bituminised trees occasionally occurring. No valuable coals, however, are worked in the Lower Miocene, which is separated from

\* Appendix to Inglefield's "Summer Search after Sir John Franklin," p. 151.

† Phil. Trans. for 1860, p. 449.

‡ Trans. Royal Soc. Edin., 1822.

the coal-bearing Middle Miocene of Ifsorisok and Assakak by several thousand feet of basalts, but the flora is similar to that of the lower fossiliferous beds. The coals of the high fells of Skandsen and Assakak are also believed to belong to this horizon.

At the creek at Atanekerdluk the general strike of the beds is E.N.E., clay, ironstone, or siderite (Atanekerdlukstour of Greenland Danes), with impressions of plants, being of frequent occurrence. Trap (basalt) dykes traverse the strata in regular lines running obliquely, and often stand out like obelisks, one of which is 80 feet in height. On the slopes occurred erratic blocks of grey syenite, &c.

It is probable that Greenland Miocene basalt extends, as suggested by Nordenskjöld, across the country north of the sixty-ninth degree of latitude, as Scoresby found impressions of plants in what he termed "trap" along the whole coast of East Greenland examined by him. The second German expedition has also brought back large collections, and it is possible that these deposits may extend under the sea to Iceland, Jan Mayen, and Spitzbergen, At Brännvinshamn, Skarfjäll, Küdliet, magnificent examples of columnar basalt occur comparable to Staffa and other European localities. At Godhavn, the lowest bed resting on the gneiss, is a basaltic tuff, with several species of zeolites, then columnar basalt, then tuff with zeolites, alternating with that basalt. At Atanekerdluk, near the shore, is a high mountain composed of crystalline dolerite similar to the Spitzbergen hyperite, and along the coast basaltic beds fifty to 100 feet thick, traversed by basaltic dykes, may be traced for miles.

On the east coast of Disco, sand and sandstone beds form mountains 1,500 to 2,000 feet, capped by basalt; in Waigat Straits these sink, and the basalt reaches the shore, but at a height of 1,000 feet, sand, clay, and coal occur.

These Miocene coals and plant-beds spread over an extensive area, for Sir John Richardson describes their occurrence on the banks of the Mackenzie, associated with gravels, sandstones, and potter's clay with plant remains, which he figured; while to the east, in Spitzbergen, a large number of species are in common, and many species also occur on the coast of the Baltic, in Switzerland, France, Italy, and Greece, four Greenland species including *Sequoia Couttsii*, so common at Bovey Tracey in Devonshire. Out of 321 species of Miocene Arctic plants now known, 167 were found in Greenland.\*

*East Greenland.*—The second German expedition is stated to have discovered † coals of Liassic age on this coast, and a large number of Miocene plants, some of which had previously been found by Scoresby in 1822.

Both the Cretaceous and Miocene rocks of Greenland appear to have been deposited in fresh water, around which grew leafy trees, including nine species of oak, of which two were evergreen, like the Italian oak; two beeches, two planes, a walnut, hazel, sumach, buckthorn, holly, and Guelder rose, proving the climate to have been a temperate and not a tropical one.

Prof. H. E. Nordenskjöld ‡ found the Greenland meteorites to be spread over an area of 200 square miles at the south-western corner of Disco Island, as Oviak or Blue Hill, both in the region of greenstone basalt, and in that occupied by granite-gneiss; the fall he believes to have taken place in Miocene times, and he describes Widmannstätten's figures as best developed in the specimens where nickelliferous wrought is mixed with nickelliferous cast iron.

The basalt he found to be consolidated basaltic ashes, and to contain fragments of the meteorites which have been forced or fallen into cracks before the tuff was consolidated. The largest block noticed probably weighed

21,000 kilogrammes; that now in the British Museum weighing about eighty-seven.

In the British Museum is an Esquimaux knife, with a bone handle, the blade composed of small pieces of meteoric iron, presented by Sir Edward Sabine, who described it in 1819 (Quar. Jour. of Science, vol. vii. p. 79), and stated that the iron was procured by the Greenlanders from a hard dark rock in a hill in 76° 10' lat., and 64° 75' long; they called the place *Sowllie*, from *sowie*, iron. Similar implements have been more recently described by Steenstrup, at the Anthropological Congress at Brussels, in 1872, and figured in *Matériaux pour l'histoire primitive de l'Homme*, 2 série, t. iv. 1873. In the third voyage of Capt. Cook, it is stated that the inhabitants of Norton Sound, Behring's Straits, call the iron they obtain from the Russians *shawie*.

M. Daurbré\* describes three distinct types of the so-called meteorites from the basalt of Oviak, discovered by Prof. Nordenskjöld: (1), a black metallic mass, which, polished, shows a network of white lamellæ (like schreibrite), and irregularly scattered grains (troilite); (2), a light grey metallic mass resembling ordinary iron; and (3), a dark green lithoid mass of silicates, with globules and grains of iron, the silica reaching in one instance 11.9 per cent. of the total weight.

	First Type.	Second Type.	Third Type.
Iron, metallic	40.94	80.8	61.99
" combined	30.15	1.6	8.11
Carbon, combined	3.00	2.6	3.6
" free	1.64	0.3	1.1
Silica	0.075	0.291	4.7
Water	2.86	0.7	...

Of soluble salts he found—

	First Type.	Second Type.	Third Type.
Sulphate of lime	1.288	0.053	0.047
Chloride of calcium	0.039	0.233	0.146
Chloride of iron	0.027	0.089	0.114
	1.354	0.375	0.307

But though differing from all other known meteorites, he considers the presence of nickelliferous iron and schreibrite to prove their meteoric origin in spite of the combination of the iron with oxygen, and the abundance of carbon and the large proportion of soluble salts, considering that the preservation of the latter may be due to the feeble tension of the vapour of the northern regions.

Dr. Walter Flight, in his recent article on the History of Meteorites, † quotes Nauckhoff, who analysed ten rocks from Oviak, and found the basalt to be a compact dark greyish green colour, of felspar (anorthite), penetrating magnetite, augite, and iron, the mass containing 49.18 per cent. of silicic acid. Tschermak describes ‡ the augite as of a light green tint, and as filling in spaces between other material, the felspar crystals as transparent, with cavities often filled with some transparent substance, and compares the Oviak rocks to the meteorites of Juvinas, Petersburg, and Stannern; and Dr. Flight compares them to old augite and anorthite lavas of Java, Iceland, and the Eiffel.

The coast of North-west Greenland, Cape York, Wolstenholme Sound, to Cape Hatherton, is described by Dr. Sutherland as composed of trap. From Cape Parry to Bardin Bay the rocks dip S.W.; further north-east to the S.W. at 30°. At Whale Sound horizontal beds of sandstone occur, but on the opposite side of Smith's Sound the cliffs are high, rugged, and inaccessible. Between Cape George Russel and Dallas Bay, Dr. Kane † describes the red sandstones as capped by greenstones, weathering into columns, one of which, 480 feet in height, he called Tennyson's Monument, overlooking Sunday Gorge in 79°.

CHARLES E. DE RANCE

(To be continued.)

\* The position of the plant-bearing localities are marked in Nordenskjöld's Chart, founded on Kink's, Geol. Mag., vol. iv. plate vii. 1874.  
 † "Zweite deutsche Nordpolarfahrt," No. viii., issued by the Bremen Committee.  
 ‡ Quar. Jour. Geol. Soc., vol. xxviii. 1872; Geol. Mag., vol. ix. p. 461, &c.

\* Comptes Rendus de l'Acad. des Sc., t. lxxiv. lxxv.  
 † Geol. Mag., vol. ii. Dec. 2. p. 154. (London, 1875.)  
 ‡ Arctic Expedition in 1855-56, by E. K. Kane, M.D., U.S.N. (Phila delphia, 1856.)



## THE PROGRESS OF THE TELEGRAPH\*

## III.

WHENEVER the finger of scientific research points the way to mechanical applications, the creative powers of the human brain originate a multitude of inventions. Too often, however, like the rank growth of weeds which spring up to choke the produce of the soil, they surround as parasites the principles involved, and by misapplied talent, frustrate the simplicity and vigour of the original idea. By hundreds in all forms and shapes have telegraphic inventions crowded into the field; but ninety-nine out of every hundred patented inventions are not worth even the fees paid to Government. As with the multitude of steam-boiler patents, so with telegraph patents, a very limited number of the different patented inventions have survived to render any really practical aid to the everyday requirements of telegraphic transmissions by land or by sea on a large scale. All the earlier inventions, the five needle, double needle, and the single needle telegraph, Bain's chemical printer, the mechanical alphabetical printer, Morse transmitter, and others of a similar type, have long since been laid on the shelf as incompetent as regards submarine cable transmissions over extended lengths; and a form of apparatus, more or less derived from a skilful combination of old principles and appliances, have taken their place for practical utility. These instruments, to which the descriptions in the present instance will be confined, may be classified into two distinct groups, namely, "recording" and "non-recording" instruments; or those which mechanically record the signals on paper, and those which are read by the eye or ear, the signals afterwards being registered by hand. Before proceeding to investigate the combinations of principles employed, it is desirable to point out that these several classes of instrument have each a special department for which they are specially adapted. Thus, for submarine cable transmissions the non-recording apparatus, depending upon the correctness of the eye or the ear, must at all times be liable to error, the accuracy and precision of sight and hearing of the reader being the only voucher that the transmitter of the message has that it has been faithfully interpreted at the distant station. Mistakes under this system must therefore, of necessity, frequently arise. Instruments of the recording type are, in consequence, always to be preferred.

In all these various forms of apparatus no new principles have been discovered; they are simply successful mechanical arrangements and combinations of certain well-known electrical laws, producing new and useful results. These fundamental principles may generally be described as follows:—

When a length of insulated wire is wound round a

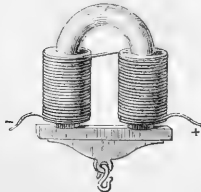

FIG. 14.—Horse-shoe electro-magnet, with armature.

piece of soft iron, and an electric current is passed through the wire helix so wound round the soft iron core (Fig. 14), the soft iron becomes a magnet and remains so, so long as the current flows through the wire; when the current ceases, the soft iron is no longer a magnet; the polarity of this magnet is reversed according to the direction in which

\* Continued from p. 452.

the current is sent through the coil or the direction in which the wire is wound round the soft iron core.

When a coil of wire surrounding a soft iron core is passed before the pole of a permanent-magnet, at the moment of passing it becomes a magnet by induction, and at the instant of making and breaking contact with the pole of the permanent-magnet, a wave of magneto-electricity is induced in the coil of wire surrounding the soft iron core. The current induced at the breaking is in an opposite direction and stronger than the current induced at the making contact. The more rapid and decided the make and break, the stronger the magneto-currents induced in the coil.

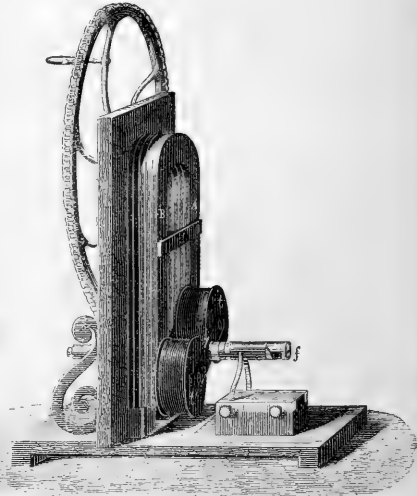

FIG. 15.—Magneto-electric machine.

A magneto-machine of this description is shown in Fig. 15. It consists of a powerful permanent magnet, A, B, composed of steel plates in the form of a horse-shoe, firmly fixed in a vertical position to a wooden frame, the two poles of the magnet being opposite to two coils of insulated wire, each furnished with a soft iron core. These two soft iron cores are connected together by an iron plate,  $L, L'$ ; the coils thus arranged constitute an electro-magnet. The electro-magnet thus formed is fixed so as to revolve round an axis,  $f$ , which passes between the poles of the magnet, and is connected with an endless chain and wheel with a handle.

When the coils are put in motion, induced currents of magneto-electricity are developed in each of them, at each successive make and break of the soft iron cores with the poles of the magnet A, B. If the wires of the coils are wound in contrary directions, the induced currents developed in each coil by the approach of the two contrary poles of the magnet will be in the same direction.

When insulated wire helices are placed round the two poles of a permanent-magnet, so that a continuous circuit is formed, and an armature of soft iron is rotated before them, at the moments of the make and break of the revolving armature with the poles of the magnet, a wave of magneto-electricity is induced in the wire helices, the stronger current being that produced by the breaking contact, which is in an opposite direction to the weaker current induced in the helices at the moment of making contact.

When the poles of two permanent-magnets are opposed to each other, the similar poles will exert a *repellant*, and the dissimilar poles an *attractive* force. This principle is constant, whether the magnets are electro-magnets or permanent-magnets.

In a permanent-magnet, as is well understood, the magnetic force culminates at the two opposite extremities of the bar, and for the purposes of telegraphy may be considered as equivalent to the force emanating from the two poles of a voltaic series, but more lasting; there is no battery to be renewed, the excitation of the current is mechanical, and not chemical.

When a piece of soft iron is placed close to the poles of a permanent-magnet (Fig. 15), it will become a magnet by induction, and the polarity of the ends will be dissimilar in their nature to those of the permanent-magnet.

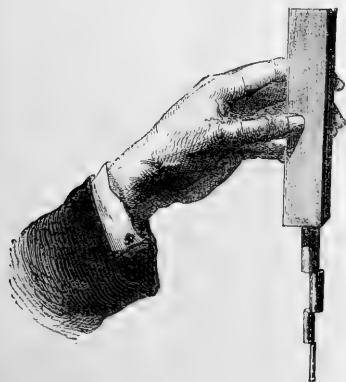

FIG. 16.—Magnetisation of pieces of soft iron by the influence of magnetism (induction).

When the pole of a permanent-magnet is placed within a hollow coil or helix of insulated wire freely suspended so as to oscillate on an axis, and a current of electricity is passed through the helix, it will be oscillated or rotated towards the right or left over the poles of the magnet according to the direction of the current.

In a similar way, when a permanent magnetic bar is freely suspended within a hollow coil or helix of wire, the magnetic bar will oscillate to the right or left, according to the direction in which the current flows through the helix.

These are the principal fundamental laws which, combined together in various mechanical details, constitute every form of telegraphic apparatus known; and it is upon the accurate balance of the resistances, and delicacy of the mechanical parts, that the excellence of the instrument for practical purposes depends. It will now be pointed out how these well-known principles have been combined to produce the beautiful machines at present employed upon submarine circuits of extended length, and by which, with feeble currents, signals are automatically recorded at the distant station.

Commencing with *non-recording* instruments, the mirror galvanometer is at once the most useful and important in its general applications to submarine telegraphy. The electrical combinations of principles which constitute this instrument existed almost in the same arrangement in the earliest days of telegraphic research. At that early period the apparatus in its elementary conditions was almost identical with the modern instrument, the bar-magnet freely suspended in the centre of a hollow coil of insulated wire, and the focal distance at which to observe the angular motion of the suspended needle to the right

or left. In this crude arrangement there existed the germ of the instrument now in use, the accurate balance of resistances, and delicate adjustments of the mechanical parts, producing the difference between an historical invention and an every-day practical mechanical application. The construction of the reflecting galvanometer is exceedingly simple, the delicacy of the instrument being the result of the lightness of the moving parts.

Two hollow coils of fine wire (Fig. 17), united to form a continuous circuit, are placed one above the other, and the coils are so constructed as to admit of a very delicate axis being inserted through them free to rotate and capable of accurate adjustment, so that the centre of rotation may be in a line with the centre of the inner ring of the coils. A minute silvered mirror reflector is attached to the axis concentric with the hollow centre of the upper coil. Two extremely light bar-magnets, about three-eighths of an inch in length, are attached to the axis in the centre of each coil, one of the magnets being therefore at the back of the mirror. The polarity of these bar-magnets is reversed, producing an astatic combination. The whole arrangement of axis, mirror, and bar-magnets is suspended by a cocoon fibre, adjustments being obtained to ensure freedom of rotation by a micrometer screw and levelling screws. The mirror is brought into the field and its motion otherwise controlled by means of a permanent-magnet sliding upon the rod, the elevation or depression of which acting by induction upon the suspended bar-magnets gives more or less sensitiveness to the motion of the mirror when a current of electricity traverses the coils. It must be obvious that the eye is quite incapable of detecting with accuracy the minute angular motions of the mirror, and that some means must be employed to magnify and increase this angular motion of the magnetic bar. For this purpose a beam of light is employed which, falling on the mirror, is reflected back again upon a long horizontal scale placed some six feet off. The angle of incidence of the beam of light being equal to the angle of reflection, the oscillation of the mirror thus magnified to the eye, to right or left, is read off from a zero on the scale. The beam of light is passed through an adjusting slit immediately beneath the scale, and the mirror is brought to the zero of the scale by the magnetic adjustment before mentioned. Thus the slightest angular motion of the mirror, inappreciable to the eye, is, according to the focal length of the ray of light, increased to such an extent as to indicate the presence of the most feeble currents with an almost inappreciable movement of the mirror.

The scientific world is indebted to Prof. Sir William Thomson for this exceedingly beautiful adaptation and combination of existing laws, parts, and principles; the skilful balance of which has resulted in an apparatus now almost exclusively used for the testing of the electric condition of submarine cables. It is obvious that with this reflecting galvanometer no automatic register of the signals received can be obtained; recourse is therefore had to a Morse key, by means of which the recipient of the signal at once records the deflection of the light spot on the scale to the right or left in the symbolic Morse code of the dot and dash. The mirror galvanometer, in fact, occupies relatively the same position in electrical mechanics as the violin does in musical acoustics. In the violin, by sliding the finger up the string and thus shortening the length of the vibrating string, the musical pitch or tone produced from the string, as the bow is drawn across it, continues to ascend in the musical scale without break; each note of the entire diatonic scale capable of being produced on that string, sliding or melting into the next, the pitch of the note being the index or record of the length of the string and numerical value of its vibrations.

In a similar manner the great peculiarity of the mirror or reflecting galvanometer is, that it continuously



local time, and the duration is about 1m. 18s. The central eclipse begins in longitude 116°·6 W., latitude 18° N.; it takes place with the sun on the meridian in 44°·8 W. and 44°·9 N., and passes off the earth in 31°·8 E. and 25°·4 N. At Greenwich the magnitude of this eclipse will be less than 0·7.

WINNECKE'S COMET.—In NATURE, vol. xi. p. 349, it was stated that the identity of this comet with that found by Pons at Marseilles, 1808, February 6, A.M., suspected by Prof. Oppöler, is open to doubt. There is contradiction in the only two accounts of this comet which we possess. In the first one, which will be found in Zach's *Monat. Corresp.* xviii., it is described as "very small;" the discovery was not made known to the astronomical public, partly because no regular observations were procured, and the strong moonlight prevented its being seen after the morning of Feb. 9. Schumacher having inquired of Pons whether amongst his papers some more definite account of this comet were to be found, received from him, through Inghirami, a communication which was printed (apparently long after its receipt) in *Astron. Nach.* vii., c. 113. Pons says the comet was one of those of which it was not possible to calculate the elements, because there were only procured some very doubtful positions by reference to nebulae in the vicinity. He adds: "Elle était très-faible et difficile à voir. Sa nébulosité était ronde; elle s'étendait à peu près un degré et on y soupçonnait par intervalle un très-faible noyau en deux parties. Son mouvement était assez rapide vers le sud. . . ." He then gives a sketch showing the configuration of the comet and two nebulae, in a telescope with a field of nearly 3°. The nebulae he describes as "sur le ventre d'Ophiuchus un peu au dessous de l'Equateur;" and Oppöler identifies them with Nos. 10 and 12 of Messier's Catalogue. Hence we have an approximate place of the comet for Feb. 9 (at 5 A.M. at Marseilles), and Pons tells us it was moving pretty rapidly towards the south. If we now adopt Clausen's elements of Winnecke's Comet for 1819 (obtained by connecting the observations of that year with those of 1858, by calculation of the perturbations), and assume the date of perihelion passage in 1808 with Oppöler on April 12<sup>o</sup>, we have the following geocentric places:—

D. H.	R. A.	N. P. D.	Distance from Earth.
1808 Feb. 5·16	Marseilles 237 56	97 0	1'044
6·17	" 239 10	97 10	1'031
8·17	" 241 39	97 31	1'007

These positions do not indicate what could be termed a pretty rapid motion towards the south, and at a distance exceeding the mean distance of the earth from the sun it is very unlikely that a comet would present an apparent diameter approaching one degree. So far as can be judged from Pons's communication to Schumacher, we may rather infer that the object he observed was very near to the earth. Clausen's elements of Winnecke's Comet in 1819 show that it was then moving in an ellipse with a period of 2031·8 days; two such periods reckoned backward from the date of perihelion passage in 1819 would bring us to 1808, June 25, instead of April 12. It does not, therefore, appear that sufficient grounds exist for supposing the comet of February 1808 to have been identical with the one which now bears Prof. Winnecke's name. We may take this opportunity of stating that according to Clausen's calculation of the perturbations, Winnecke's Comet was in perihelion on the following dates between the appearances in 1819 and 1858, passing unobserved in each year: 1825, Feb. 55, G.M.T.; 1830, Aug. 21·4; 1836, March 3·4; 1841, Sept. 13·9; 1847, March 29·0; and 1852, Oct. 11·7.

THE STAR B. A. C. 2695.—This sixth-magnitude star of the British Association Catalogue was missed in August last by Mr. Tebbutt, of Windsor, N.S.W., being then invisible

in a telescope of 4½ inches aperture. It is No. 1871 of the Paramatta Catalogue, where the place depends upon a single complete observation, the magnitude attributed to the star being 6. It is also No. 966 of the catalogue in the fifth volume of Taylor's Madras Observations, the position depending upon two observations in each element in 1838 or 1839, but the recorded magnitude is 10. So great a difference in the estimated brightness clearly points to variability, which is confirmed by Mr. Tebbutt's recent notice. The position for the beginning of 1875 is in R.A., 7h. 57m. 30s., N.P.D. 150° 9' 7"; five minutes distant from this star, on an angle of 180°, is the sixth-magnitude B.A.C. 2694, which Mr. Tebbutt found "decidedly red." It may be remarked that the fifth volume of Taylor's Madras Observations, to which reference is made above, is by far the most valuable of his series to the astronomer in the southern hemisphere; but it is not, we believe, now easily procured.

THE "TIMES" WEATHER CHART

MANY of our readers will have noticed the unusual appearance of illustrations in the *Times* in the shape of the small charts which have been appended to the Daily Weather Reports since the 1st inst. This measure has been the long-postponed carrying out of the line of action indicated by the Meteorological Committee in their Report for last year, and the chart in its present form differs but little from that printed as a specimen in that Report. We subjoin the chart for the 13th inst., 8 A.M., published in yesterday's *Times*.



The dotted lines indicate the gradations of barometrical pressure, the figures at the end showing the height, with the words "Rising," "Falling," &c., as required. The temperature at the principal stations is marked by figures, the state of the sea and sky by words. The direction and force of the wind are shown by arrows, barbed and feathered according to its force. © denotes calm.

The method of preparation of the chart seems simple enough at present, but it has been the fruit of much thought, as the problem of producing, in the space of an hour, a stereotype fit for use in a Walter machine has not been solved without many and troublesome experiments.

In the first place, a material had to be provided which would admit of being engraved rapidly without burr or chipping, and would, without further preparation, serve as a mould for type metal. Secondly, drill pantographs had to be adapted to engrave the lines, and to be furnished with a gauge so as to vary their depth at pleasure.

The actual process is as follows:—The outline of the land is kept standing, and the composition is run in a mould bearing this outline on one face. The block, which is now an outline chart of the British Islands, is then placed under the pantograph drill, which reduces the original drawing, furnished from the Meteorological Office, to one-fourth. The barograms and wind-arrows are put on direct from the drawing, the figures and words by means of templates, in order to ensure uniformity in the type.

The instant the block is engraved it is ready to be stereotyped, and then it is a simple matter to adapt it in the usual manner to the cylinder of the machine.

The initiative in this new method of weather illustration is due to Mr. Francis Galton, and the practical details have been carried out by Messrs. Shanks and Johnson, of the Patent Type Founding Company.

It is hardly necessary to allude to the value of such charts as these as a means of leading the public to gain some idea of the laws which govern our weather changes. As soon as they appear in our afternoon papers, we may hope for a more intelligent comprehension of the difficulties which beset any attempt to foretell the weather of these islands for the space of even twenty-four hours.

We may safely say that with these charts we have not seen the end of weather illustration, which was set on foot more than four years ago by Sir W. Mitchell in the *Shipping Gazette*, and has been continued daily; but whatever improvements may hereafter be introduced in the process, it must be remembered that the credit of breaking the egg is due to the gentleman we have named.

#### THE ECLIPSE EXPEDITION

THE local arrangements for the Eclipse parties, to which we referred last week, have, we now know, been altered in the cases both of the Bay of Bengal and Siam parties.

With regard to the former, letters received from Galle, written shortly before the sailing of the *Enterprise* (which had arrived at that port from Calcutta with Capt. Waterhouse, Profs. Tacchini and Pedler, and three photographic assistants on board), state that it had been determined to give up Mergui, first because the accommodation there was doubtful, and secondly, because, in the opinion of those best informed, a cloudless sky at Camorta was almost a certainty. Hence there will be two strong parties on Camorta itself as widely separated as possible; and here, it will be remembered, the totality is longer than at any other station; being no less than 4m. 27s. at Kaikul.

The Indian Government had been careful to prepare huts for observatories on this island before even the *Enterprise* had left Calcutta; and as certain parts of it are known to be malarious, all the observers will sleep on board the steamer.

With regard to the Siam party, a Reuter's telegram, dated Singapore, April 8, shows that this party, instead of going direct to Chulai Point, has gone to Bangkok; and it would appear from the telegram that the observatories were being erected at some spot nearer Bangkok than the proposed station.

#### NOTES

It is with the greatest satisfaction we record that on Tuesday Mr. James Dewar, Demonstrator of Chemistry in the University of Edinburgh, was elected to the Cambridge Jacksonian Professor-

ship; all the other candidates having withdrawn. As our readers know, Mr. Dewar has already done excellent work, and is so widely known as a gifted investigator as well as a first-rate teacher, that his presence at Cambridge will be a great gain, not only to that University, but to English Science.

THE *Alert* and *Discovery*, the two ships destined for the Arctic Expedition, are to be commissioned to-day. In addition to the naturalists specially appointed, Captain Markham and several of the lieutenants and sub-lieutenants have been undergoing special instruction in the instruments they will have to use—astronomical instruments, pendulums, magnetometers, and spectroscopes.

AT Monday's sitting of the French Academy of Sciences, a letter was read from M. Puiseux, giving a *résumé* of his calculation for the solar parallax, founded on the recent Transit observations. M. Puiseux has made a comparison between the St. Paul Transit observations by Mouchez, and those of Pekin by Fleurbaey. The exact amount of the parallax is 8'879". Both observers had 6-inch refractors. The comparison of the results obtained by Fleurbaey and another observer at St. Paul with a 4-inch refractor gives 8'84". M. Puiseux, in computing the sources of error, states in his letter that the error cannot be more than  $\frac{1}{37}$  of a second, by supposing the error to be two or three seconds of time for the moment of transit. M. Puiseux spoke briefly in support of the opinion expressed in his letter.

THE following from the *Kölnische Zeitung* of March 25, in reference to the recently invented "hardened glass," will be interesting:—According to the reports of Pliny, Petronius, and Dion Cassius, a man is said to have invented the making of flexible and malleable glass in the time of the Emperor Tiberius. The happy inventor—some call him a glass-maker, others an architect—brought to the Emperor a vase made from the new glass, with the hope of a rich reward. The Emperor, fearing that the new material might cause a decrease in the value of gold and silver, threw the vase to the ground in a passion. The vase, however, did not break, but was only bent like metal, and the inventor at once repaired the damage done with a little hammer; whereupon the Emperor had the poor fellow killed on the spot, so that he should not tell his dangerous secret to anyone. For years people have lost themselves in conjectures of what material this malleable glass might have been; some thought it was aluminium, others that it was melted chloride of silver; none, however, were certain. From various quarters the invention is now announced of a new glass which resists blows and the action of fire. Last autumn a company was formed at Bourg, in France, with a capital of 1,200,000 francs, for the working of an invention in this line, made by a M. de la Bastie. The German Glass-makers' Union communicated with this company with a view to purchase the invention, but this remained without further consequences, as the demands of the company were exorbitant. In the meantime it had been found that the elasticity was given to the glass by dipping the same, while it is heated to a half liquid state, into a hermetically closed bath of oil or fat, substances therefore which melt far below the boiling-point of water. In Silesia, where repeated experiments have tested the qualities of the De la Bastie glass, another new glass was invented a few days ago, by Herren Lubisch and Riederer, in Count Solm's glass-works, Andreaehütte, at Klitschdorf, near Duzslau. This glass, which the inventors call "metal glass," is so hard, that when a pane lies on the ground and a leaden ball of forty grammes weight falls upon it from an elevation of twelve feet, it receives not the slightest impression; nor is it in the least affected when dipped whilst red-hot into cold water. Window panes, lamp cylinders, and other articles of domestic use made from this metal glass, can therefore almost be denoted as unbreakable.

Mr. H. C. SÖRBY, F.R.S., has sent us the following:—  
 "In the early part of this year I was much interested in reading in the *Naturforscher* an account of a paper communicated to the *Accademia dei nuovi Lincei*, in Rome, by Count Castracane, on the discovery of Diatomaceæ in the ashes of English coals. Thinking it desirable that the attention of the members of the Royal Microscopical Society should be directed to this fact, I wrote to Count Castracane, requesting him to send to me some specimens. I have now received two mounted objects of the ashes of coal shipped from Liverpool, which will be exhibited at the *soirée* on Wednesday, April 21st. I trust that this will be the means of leading some of the Fellows to devote themselves to this kind of inquiry, since they will be able to see that the specimens contain not only several well-preserved species of Diatomaceæ, but also other curious bodies somewhat like, yet differing from, the *Xanthidea* found in flints."

M. WALLON, who is the Perpetual Secretary of the Academy of Inscriptions, as well as Minister for Public Instruction, resumed his academical functions last Thursday. He had to read over a number of letters written to him, the Perpetual Secretary, by himself, the Minister; and his colleagues were struck with the serious way in which he performed his duties as secretary. One of them, M. de Saulcy, having asked the Academy to send two learned men on a mission to some place, said to M. Wallon: "If M. le Secretary is good enough only to speak a few words to M. le Minister, I am perfectly certain the Minister will find no objection to my proposition."

M. PAUL PERNY, a former pro-Vicar Apostolic in China, has proposed to found a European-Chinese Academy in the heart of China, to be composed of missionaries, for the purpose of discovering, translating, and circulating in Europe, Chinese works of every kind bearing on the sciences, arts, and industry. M. Perny states that the Emperor Kien-Lung, who lived upwards of a century ago, drew out the plan of a general encyclopædia of human knowledge, which has not a parallel in the world. The publication of this encyclopædia is still going on. Nearly 100,000 volumes have appeared; there remain 60,000 volumes to be published in order to complete the scheme of the Emperor. The Chinese have encyclopædias of more than 300 volumes on agriculture, horticulture, pisciculture, &c.

THERE is an increasing demand for land in Ceylon for the purpose of growing tea, cinnamon, cinchona, vanilla, and other useful plants for economical purposes, as well as for the spread of the coffee plantations. A disease in the coffee plant has lately been discovered which threatens scarcity of this product unless speedily checked. It is called "leaf disease," and, as its name implies, is principally apparent in the death of foliage, though the produce of the berries is also considerably reduced. It is believed by competent authorities to be mainly caused by exhaustion; and is, in this respect, similar to the disease among the lemon groves of Europe, to which we alluded a week or two ago. The Government of Ceylon have taken up the subject with a view to its thorough investigation.

THE Acclimatisation Gardens in the Bois de Boulogne, Paris, have received a rare collection of artificially coloured plants from China. The plants are exhibited in the great glass house of the gardens, and excite universal admiration. Among the collection is a dwarf-tree of half a metre in height, the trunk of which is as thick as a finger, and the root of which hardly fills the hollow of a man's hand; the specimen is about 100 years old, and is a species of oak. This, however, is not a natural phenomenon, but the result of Chinese horticulture, which finds its highest problem in the reduction of the natural size of plants.

WE draw the attention of friends of geography to the *Hydrographische Mittheilungen* (Berlin, E. S. Mittler), which form the

supplement to the publications of the Imperial German Admiralty *Nachrichten für den Seefahrer*; they have been published since 1873, and are most excellent in every way. The part for 1874, for instance, contains a detailed description of the Kerguelen Islands, a climatological picture of the Azores and Madeira, a treatise by Neumayer on the geographical problems in the Arctic regions, and a number of other interesting articles.

HEET iv. of Petermann's *Mittheilungen* contains a letter from Dr. Oskar Lenz, dated Adolinolonga, on the Ogowe, which falls into Nazareth Bay, near Cape Lopez, just under the equator, giving a brief account of some short excursions he made last autumn in the district on the lower course of that river. The scenery, natives, fauna, and flora are characteristically Central African, and Dr. Lenz has been able to make considerable collections, including a large number of gorilla skulls. He seems to have been much hindered by sickness.

DR. GUSTAV LEIPOLDT, in a recently published work on the "Mean Height of Europe," after an elaborate calculation founded on a broad basis of measurement, concludes that it is 296'838 metres, 92 metres higher than the calculation of A. von Humboldt, who indeed made out the average altitude of all the land on the earth to be about 308 metres. The mean height of Switzerland, Leipoldt makes to be 1299'91 metres, while that of the Netherlands is only 9'61 metres. That of Great Britain is 217'70. Further interesting details will be found in the April number of Petermann's *Mittheilungen*.

THE same journal contains a map of Kerguelen Island, reduced from the English Admiralty Chart to a scale of 1—500,000. For comparison a map of Malta on the same scale is printed on the sheet, and gives one a very fair idea of the size of the southern island, which must be something like fifteen or twenty times the size of Malta. Accompanying the map are some remarks on the history and condition of the island.

IN the same number of Petermann's journal, Baron N. Schilling, of St. Petersburg, discusses the fertile subject of the theory of ocean currents.

AT the meeting of the Diplomatic Conference on the Metrical System, at Paris, on April 12, it was agreed to organise an International Bureau of Weights and Measures, the cost of maintaining which would be divided between the States represented at the Conference.

THE discovery of a boiling lake in the Island of Dominica is announced. It is stated to be situated in the forest-covered mountain behind the town of Roseau, 2,500 feet above the sea, and to be two miles in circumference. The margin of the lake consists of beds of sulphur, and its overflow finds exit by a waterfall of great height.

AT Monday's meeting of the Geographical Society, a paper by Mr. John Forrest was read, on his journey across the centre of Western Australia, referred to in *NATURE*, vol. xi. p. 93. Mr. Forrest is expected to arrive in England in the beginning of next month.

THE death is announced of the Rev. Charles New, the African missionary, who has made several additions to our knowledge of South Africa, and who is known specially for his ascent of the mountain Kilimanjaro. At the meeting of the Geographical Society on Monday, a paper by Mr. New was read, "On the Overland Route from the Pangani to Mombassa." Mr. New died from dysentery soon after this journey.

THE following lectures in Natural Sciences will be given at Trinity, St. John's, Christ's, and Sidney Sussex Colleges, Cambridge, during Lent Term, 1875.—On Electricity and Magnetism (continued), by Mr. Trotter, Trinity College, commencing April

15. On Electricity and Magnetism (continued), and on Heat, by Mr. Trotter, Trinity College, commencing April 14. On Chemistry (continuation of the course begun in the Lent Term), by Mr. Main, St. John's College, commencing April 13. Instruction in Practical Chemistry will also be given. On Palæontology (the Mollusca), by Mr. Bonney, St. John's College, commencing April 15. On Geology, by Mr. Bonney, St. John's College, commencing April 14. There will be excursions every Saturday, beginning April 17. Elementary Geology, commencing April 15. On Botany, by Mr. Hicks, Sidney College, beginning April 17. The Lectures this Term will be on Vegetable Physiology, and on Cryptogams. On Elementary Biology: a Practical Course at the Physiological Laboratory by the Trinity Preelector in Physiology (Dr. M. Foster), beginning April 15. On Animal Histology, by Mr. Martin, Christ's College.

At St. John's College, Cambridge, J. E. Marr, from Lancaster Grammar School, has been elected to an Exhibition for Natural Science, of 50*l.* per annum, tenable for three years. C. Slater, from Clifton College, has also been elected to one of 33*l.* 6*s.* 8*d.*, tenable for the same time.

A CORRESPONDENT informs us of an interesting discovery in the Rhenic beds at Westbury-on-Severn. A party of students from Gloucester, in examining the Cardium shales, found a few specimens of a starfish, which Dr. Wright of Cheltenham, to whom specimens were forwarded, has pronounced to be his *Ophiolepis Damesii*, first found in the Rhenic beds at Hildesheim, and described by Dr. Wright in the *Zeitschrift der Deutschen geologischen Gesellschaft*, Jahrgang 1874. The specimens do not quite correspond with the plate (xx'x.) of the Transactions alluded to, though the plate scarcely answers Dr. Wright's description.

AMONG the various kinds of fish which might with advantage be introduced into this country from America, perhaps none offer such good results as the Shad (*Alosa sapidissima* and *A. pseudo-harengus*). These American Shad are very much superior to any European species; and one of their chief merits is in the enormous shoals in which they enter the rivers. Some idea of this may be gathered from the fact that 5,000,000 pounds of the Shad and the closely allied "Alewife" were inspected as food for the market of Washington alone during the months of May, June, and July, 1874. No greater boon could be conferred upon Great Britain than the transfer of these two species of fish into its waters. An attempt has been made to transport this fish into Germany, but failed, owing to the length of time involved in the voyage. Very little difficulty is anticipated in such an experiment in regard to this country; the young fish could, in the opinion of American fish culturists, be easily brought over.

IN connection with the recent meeting of the French Learned societies, Mr. G. J. Symons writes from Paris as follows:—"M. Michel threw out a suggestion which appears to me likely to, or at any rate possibly may, be the means of averting the principal source of danger in crossing the Atlantic. I refer, of course, to icebergs in foggy weather and the total wrecks which occur from running on to them. It is well known that the proximity of icebergs is indicated by a diminution in the temperature of the sea. M. Michel's proposal is very simple: it is merely that Transatlantic steamers should carry a submerged electric thermometer, which might easily be arranged to ring a bell in any part of the vessel on the occurrence of whatever change of temperature might be decided upon."

A RECENT letter in the *Times* states that a cross halo was seen on the night of the 14th March. On the same night at sunset a halo was observed by M. de Fonvielle, and described by him in his daily meteorological article in the *Paris Temps*. It was a circular halo, no trace of the cross being seen. It does not

appear that the phenomena were produced by the same cloud, as the clouds were drifting southwards. But halos were very frequent about that time. On the 12th a solar halo was seen by M. de Fonvielle, and noted in *NATURE*, vol. xi. p. 395. The same cirrus may present, when seen from different altitudes, different appearances; this is proved by the variations of aspect observed by M. Tissandier in his last ascent.

AT the *conversazioni* of the Quckett Club to be held at University College to-morrow night, Mr. J. F. Tafe will exhibit some specimens of the Colorado Potato Beetle.

THE large refractor (fourteen inches) of the Paris Observatory, which was damaged during the Communal disturbances, is now being restored. The roof, which had been perforated by hundreds of balls, will be put in working order. This refractor will be exclusively devoted to celestial photography.

THE publishers of the "Instructions for the Observation of Phenological Phenomena," referred to in a recent number (p. 408), are Williams and Strahan, Lawrence Lane, Cheapside. We believe that forms for recording observations may be obtained by application to the Secretary of the Meteorological Society.

*The Colonies* is the title of a fortnightly journal published by Silver and Co., which gives the cream of the news from the colonial possessions of Great Britain. Each issue contains one or more papers of a scientific nature on subjects connected with the colonies. The subjects are well selected, and the information is generally accurate and valuable. The number for April 3 contains two interesting papers; one on the races of man inhabiting New Guinea; and the other on the Lac insect and its commercial products (illustrated).

THE *Natal Colonist* for Feb. 26 contains an interesting paper on "The Bee-tailor and the Crane or Windlass Spider: Instinct or Reason?" The *Natal Colonist* deserves to be commended for the interest it has always shown in scientific matters; it has ever been ready to open its columns to contributions on subjects of scientific interest. In a note prefixed to the paper the editor states that he wishes to enlist the "sympathies and the aid of those readers who are observers and students in the various branches of Natural History," so as to follow up the paper referred to with a succession of similar records of observations. We hope the invitation will meet with a response from many quarters. To quote the words of the preliminary note, "We feel assured that there are many throughout the colony whose observations of the habits of animals, of the characteristic products of their own localities, whether animal or vegetable, and the like, would be of great interest to others, and possibly very materially conduce to the advancement of science, and we should be glad indeed to make our journal the vehicle of communicating such records to the public." The Town Council of Durban, we are glad to see, contemplate setting apart a portion of the new buildings for the purposes of a museum.

THE additions to the Zoological Society's Gardens during the past week include a Green Monkey (*Cercopithecus callitrichus*) from West Africa, presented by Mrs. Lange; a Vervet Monkey (*Cercopithecus islandii*) from West Africa, presented by Miss Emily Sission; a Golden Eagle (*Aquila chrysaetus*) from Spain, presented by Mr. J. Arthur Wright; two Leadbeaters Cockatoos (*Cacatua leadbeateri*) from Australia, presented by Mr. G. L. Prendergast; two Shoveller Ducks (*Spatula clypeata*), European; a Blue-faced Green Amazon (*Chrysothrix boucqueti*) from St. Lucia, West Indies, purchased; an Ocelot (*Felis pardalis*) from South America; a Porto Rico Pigeon (*Columba corensis*) from St. Vincent, purchased.



## ACCIDENTAL EXPLOSIONS \*

## II.

THERE is no doubt whatever that a very considerable proportion of the accidents which occur to persons using petroleum lamps are really traceable to the erroneous belief, which is still so very prevalent, in the explosive character of these liquids. The fact that they and their vapours are simply inflammable, and that the latter requires to be mixed with a large volume of air before their ignition can be accompanied by explosive effects, is so slowly realised, that in public prints petroleum is still often spoken of as an explosive substance. The popular belief in the explosiveness of these simply inflammable liquids contrasts strangely with the fact that many explosions have been brought about by the careless employment of candles or other naked flames in premises where the volatile varieties have been stored, or where the operation of transferring the liquid from one vessel to another for purposes of sale is carried on, the result being the ignition of the explosive mixture produced by the volatilisation of the spirit and its diffusion through the air. This fact does indeed tend to discourage the hope that the proportion of accidental explosions of gunpowder which are apparently due to ignorance may become very greatly diminished by keeping its explosive properties before the minds of those using it.

The lecturer then referred to the legislative restrictions in connection with the transfer, storage, and sale of petroleum and petroleum oils. The danger arising more especially from the transport and storage of imperfectly refined oils under designations which apply to the properly refined and therefore safe petroleum- or coal-oils, which do not demand special precautions for their safe storage and use, and are consequently not subject to any restrictive or precautionary regulations, renders the application of the existing legal regulations to the inspection of petroleum-oils imported into England of special importance. Referring to the so-called *flashing-test* described in the Act of Parliament, Prof. Abel thinks it undoubtedly desirable, in the framing of any future Act, that this test should be carefully reconsidered, as well as the question whether some narrow limit below 100° F. may not reasonably, and without incurring any increased risk, be fixed within which the flashing point of an oil (*i.e.* the temperature at which it evolves vapour) may range,†

The liability of oil or spirit to leak from casks or barrels even of the best construction, consequent upon the rough usage to which these are unavoidably subjected when transferred from store to ship or carriage, and the reverse, need scarcely be pointed out. But even in the absence of leakage from the openings of the barrels, or from any accidental point of escape, evaporation or diffusion of the volatile petroleum will occur through the wood itself of which they are constructed, especially in the warm holds of ships or in stores exposed to the sun, even though the precautionary measure is frequently adopted of rinsing the barrel out before use with a solution of glue. It is evident that the object of imparting an impervious coating to the interior of the barrel can thus be only very imperfectly attained, and that, even if it were, the alternations of temperature to which the barrels must be exposed must in course of time open up places for escape by leakage or evaporation.

The dangers resulting from the escape of petroleum spirit or its vapour from receptacles in which it is kept, in confined spaces, where little or no ventilation exists, has been but too frequently exemplified by explosions more or less violent, followed by fires in localities where it is stored or handled, or in the holds of vessels in which it is transported. Accidents of such kinds have been due either to carelessness in transferring petroleum from one vessel to another, in a shop or store in which a light has been burning at the time, or to a light being carried into or a match struck in a store where vapour has been escaping until it has formed an explosive mixture with the air. The lecturer had a vivid recollection of an accident of this kind which he witnessed at the Royal College of Chemistry in 1847. Mr. C. B. Mansfield, who was then engaged in his important researches on the composition of coal-tar naphtha, which led a few years afterwards to his sad untimely death, was engaged at one extremity of a low

room (38 feet long, about 30 feet wide, and 10 feet high) in converting one of the most important of these products—benzol—which boils at 176° F.) into nitrobenzol in a capacious retort, which suddenly cracked, and, yielding to the pressure of its contents, allowed the warm liquid hydro-carbon to flow over the operating table. There was a gas-flame burning at the other extremity of the laboratory, and no other source of fire. Within a very few minutes after the fracture of the vessel a sheet of flame flashed from the gas-flame along the upper part of the room and communicated to the table upon which the liquid had been spilled.

Among other "accidents" referred to as arising from a similar cause, was the recent explosion of the powder-laden barge in the Regent's Canal. It was established by a sound chain of circumstantial evidence that this explosion must have been caused by the ignition, in the cabin of the barge, of an explosive mixture of air and of the vapour of petroleum, derived from the leakage of certain packages of the spirit which were packed along with the powder.

It is impossible to protect heavy packages from rough usage, in the processes of unloading ships or other vehicles of conveyance; it is therefore most important that means should be adopted of thoroughly closing the vents of receptacles of petroleum-spirit by such means as are capable of sustaining ordinary rough usage without any injury to their efficiency, and that the improvement of the nature and construction of the receptacles themselves be seriously considered with the view of reducing the liability to accidents resulting from the escape of the spirit or its vapours, and the consequent creation of danger connected with the transport and storage of these valuable illuminating materials.

The fact that combustible, and especially inflammable, solid substances, if of sufficiently low specific gravity, and reduced to a sufficiently fine state of division to allow of their becoming and remaining for a time suspended in air, may furnish mixtures with the latter which partake of explosive character, scarcely needs to be pointed out. The ignition of a particle of such a substance, surrounded by atmospheric oxygen, will, under these conditions, at once communicate to others immediately adjacent to it, and if the particles of suspended solid matter be sufficiently numerous and finely divided, the ignition will spread throughout the mixture with a rapidly approaching that of a mixture of inflammable vapour and air, the development of gaseous products and heat being sufficiently rapid and considerable to produce explosive effects, which may even be of violent character, their violence being regulated by the nature and inflammability of the solid substance, the proportion and state of division in which it is distributed through the air, the quantity of the mixture, and the extent of its confinement.

Explosions of an accidental nature produced in this way are believed to have occurred in connection with operations in the chemical laboratory; but it was scarcely to be expected that the first clearly authenticated cases of any importance should have arisen out of the apparently harmless operation of grinding corn.

That a mixture of very fine flour and air will ignite with a flash when light is applied to it, and produce in a very mild form the species of explosion observed on applying a light to lycopodium suspended in air, is not very difficult of demonstration, but it is not easy to realise the possibility of the production of violent explosive effects by the ignition of such a mixture even upon a very large scale, though the rapidity of its ignition be accidentally favoured by the warmth of the atmosphere. Cotton mills have been known to be rapidly fired by the ignition of cotton particles suspended in the air; but, compared with flour, cotton is very combustible. Flour when absolutely dry would contain only about half its weight of carbon, and about six per cent. of hydrogen, the remainder consisting of nitrogen and mineral substances; constituents which, by absorbing heat instead of contributing to its development, must tend to reduce the rapid combustibility of the substance. Yet the possibility of very serious calamities arising out of the accidental ignition of a mixture of flour-dust and air has been but too conclusively demonstrated.

Referring to a destructive explosion in some extensive steam flour-mills in Glasgow in July 1872, the lecturer said that its origin was conclusively traced to the striking of fire by a pair of millstones, through the stopping of the "feed," or supply of grain to them, and the consequent friction of their bare surfaces against each other, the result being the ignition of the mixture of air and fine flour-dust surrounding the mill-stones.

This ignition alone would not suffice to develop any violent

\* Abstract of a lecture delivered at the Royal Institution, March 12, by Prof. F. A. Abel, F.R.S. Continued from p. 439.

† As the law at present stands, an oil, the flashing-point of which is declared to be 99° by the official inspector, must be condemned; but another operator may make the flashing-point of the same oil to be slightly above 100°. Practically, an oil with a flashing-point of 97° or 98° would be quite as safe as one which answers to the test at 100°, in the hands of the same operator.

explosive effects; such ignitions, though occasionally observed in small mills, being caused either by the striking of fire by the stones, or by the incautious application of a light near the millstones, or the meal-spout attached thereto, have not in these instances been attended by any serious results. But in an extensive mill, where many pairs of stones may be at work at one time, each pair has a conduit attached to it, which leads to a common receptacle called an exhaust-box; into this the mixture of air and very fine flour-dust which surrounds the millstones is drawn by means of an exhaust-fan, sometimes aided by a system of air-blowers. The fine flour is allowed to deposit partially in this chamber or exhaust-box, and the air then passes into a second chamber called a stive room, where a further quantity of dust is deposited. It follows that when the mill is at work these chambers and the channels or spouts connecting them with the atmosphere immediately surrounding each millstone, are all filled with an inflammable mixture of the finest flour-dust and air, and that consequently the application of a light to any one of those channels, or the striking of fire by any one of the millstones, by igniting some portion of the inflammable mixture, will result in the exceedingly rapid spread of flame throughout the confined spaces which are charged with it, and will thus develop an explosion. The violence of such explosions depends much upon details of construction of the exhaust-boxes and stive rooms, and upon the dimensions of the channels of communication; it must obviously be regulated by the volume of inflammable mixture through which fire rapidly spreads and upon the extent of its confinement.

The subject of flour-mill explosions, though it has attracted little if any attention in this country previous to the Tradeston explosion, is discussed in continental treatises on flour-mills, and the results of Professors Rankine and Macadam's inquiries have demonstrated that accidents of this kind are actually of ordinary occurrence in mills, especially since the introduction of the exhaust arrangements. Those gentlemen point out that it appears scarcely possible to guard against such accidents altogether, although the frequency of their occurrence may probably be much reduced by adopting efficient precautions to prevent, as far as possible, a stoppage of the "feed" to the millstone, or the accidental introduction of nails between them together with the grain, and by prohibiting the employment of naked lights in the vicinity of the mills and the dust passages. In order to reduce as far as possible the damage and risk of sacrifice of life resulting from such explosions, it is important that all receptacles into which the dust-laden air is drawn from the mills should be fixed outside the buildings, and constructed so as to offer as little resistance as possible to the sudden expansion resulting from the ignition of the inflammable mixture. The conduits leading from the mills to the exhaust chambers should, moreover, be of small dimensions, and there should be no other communication between the interior of the building and the dust receptacles, which must not be opened while the mill is at work. By adopting precautions of this kind the mill-owner may succeed, at any rate, in reducing the mischief resulting from an accidental ignition of flour-dust at the millstones to such limits that the mill itself and the lives of those engaged in it will not be endangered.

The production of explosions by mixtures of air with marsh gas, coal gas, petroleum vapours, or a finely divided inflammable solid such as flour, has been shown to be due to the application of sufficient heat to some portion of the mixture to cause the atmospheric oxygen to combine with the combustible constituents of the gas, vapour or solid, the results being the development of chemical action, the formation of gaseous products, and their expansion by the heat developed. It need scarcely be said that the same explanation applies to the production of explosions by that class of so-called explosive agents which is prepared by intimately mixing combustible or inflammable solids with a solid oxidising agent (*i.e.*, an oxygen compound which readily yields up a part or the whole of that gas under the influence of heat, and with the co-operation of chemical force, to carbon, hydrogen, or other readily oxidisable elements). Distinct from these explosive mixtures as regards their nature, but quite analogous to them in their behaviour and the effects they produce when subjected to heat or other disturbing influences, are explosive compounds. The majority of these contain carbon, hydrogen, and oxygen as the most important components; they are more or less susceptible of sudden or extremely rapid transformation into gases or vapours, attended by development of great heat, in consequence either of their resolution into their elementary constituents, or generally of the rearrangement of these into comparatively simple forms of combination. Some of these explosive compounds are of such unstable character that they are liable to

undergo change from very slight inciting causes, such as the existence in them of minute quantities of foreign substances of active chemical character; or they may even be prone to absolutely spontaneous change. In such substances decomposition may be in the first instance established only to a very minute extent, but this decomposition, by the products to which it gives rise, and by the attendant development of heat, however small, may speedily promote further and more rapid change in the mass of the substance, so that eventually decomposition of violent nature may be established, and the principal portion of the compound may suddenly undergo the same transformation into gases or vapours, attended by the same development of heat, as though any one of the agencies (*i.e.*, fire, friction, or percussion) ordinarily employed to determine the explosion of these bodies had been applied. Cases of so-called spontaneous explosion thus brought about are more familiar to scientific and manufacturing chemists than to the general public, but accidental explosions of very alarming, and, in a few instances, of very calamitous character, are on record which, though not actually of spontaneous nature, in the strict application of the term, have been brought about without any apparent application of external inciting agencies, and have hence, from a practical point of view, not been incorrectly classed as spontaneous explosions.

(To be continued.)

## SOCIETIES AND ACADEMIES

### LONDON

Mathematical Society, April 8.—Prof. [H. J. S. Smith, F.R.S., president, in the chair.—Mr. G. H. Darwin gave an account of two applications of Peaucellier's cells, first, to "the mechanical description of equipotential lines"; and secondly, to "a mechanical method of making a force which varies inversely as the square of the distance from a fixed point." In this latter case, let  $o$  be the fixed pivot of a cell, and suppose the cell to be in equilibrium under the action of two faces,  $P$  and  $P'$ , acting at  $D$  and  $B$ . Then by the principle of virtual velocities—

$$P' \cdot \delta \cdot oD + P \cdot \delta \cdot oB = 0. \text{ Now, } oD \cdot oB = oA^2 - AD^2$$

$$\therefore \frac{\delta \cdot oD}{oD} = -\frac{\delta \cdot oB}{oB} \therefore P' \cdot oD = P \cdot oB$$

whence

$$P = \frac{P'(oA^2 - AD^2)}{oB^2}$$

If then  $P'$  is a constant force acting away from  $o$ ,  $P$  is an attractive force varying as  $oB^{-2}$ . Mr. Darwin stated that the idea

was the joint production of his brother Horace and himself, and that he entertained the hope that it would be possible to construct a toy to give an ocular proof of elliptic motion. A rough model was exhibited. Sir W. Thomson, F.R.S., expressed his pleasure at having heard the communication, as he had himself failed in trying to get a mechanical means of making such a force.—Sir W. Thomson then made two communications to the Society: one on the integration of the equations for the motions of a system acted on by forces expressed by linear functions of the displacements and velocities; the other on the vibrations of a stretched string of gyrostats (dynamical theory of Faraday's magnetic rotation of the plane of polarisation).—Prof. Cayley, F.R.S., made a few remarks on some integrals connected with the theory of attractions.—Mr. Tucker, hon. sec., then read a portion of a paper by Prof. Wolstenholme. The problem discussed in this paper is thus enunciated:—A tube of fine uniform bore is bent into the form of a regular polygon of  $n$  sides, and filled with equal volumes of  $n$  different fluids which do not mix; it is then closed, and held in any position in a vertical plane. The sides of the polygon formed by joining the common surfaces of the different fluids will always have constant directions; but if two conditions be satisfied, every position will be one of equilibrium. He applies his results to a few simple cases; thus, if  $n = 3$ , and the densities be in arithmetical progression, the straight line joining the ends of the fluid of

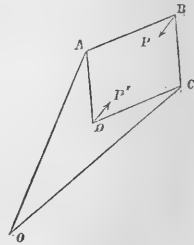

mean density will always be vertical. Again, if  $n = 4$ , and  $\rho_1 + \rho_4 = \rho_2 + \rho_3$  ( $\rho_1, \rho_2, \rho_3, \rho_4$  being the densities of the fluids), then the diagonals of the square formed by the surfaces of the fluids will be vertical and horizontal. This instrument, Prof. Wolstenholme suggests, might possibly be used as a level and plumb-line; or perhaps, also, some interesting toys might be made by other polygons.—A paper by Prof. J. Clerk-Maxwell, F.R.S., on the application of Hamilton's characteristic function to optical instruments symmetrical about an axis, and the value of the function for a spherical surface, was taken as read.

Geological Society, March 24.—Mr. John Evans, V.P.R.S., president, in the chair.—The President announced that the late Sir Charles Lyell had bequeathed to the Society the sum of 2,000*l.* for the purposes stated recently in our Notes, p. 434.—Prof. Prestwich proposed and Mr. W. W. Smyth headed the following resolution:—"That this meeting, having heard the announcement of the bequest made to the Geological Society by the late Sir Charles Lyell, desire to record their deep sense of the loss the Society has sustained by his death, and their grateful appreciation of the liberal bequest for the advancement of geological knowledge placed at their disposal by their late distinguished Fellow."—The following communications were read:—On the occurrence of phosphates in the Cambrian Rocks, by Henry Hicks, F.G.S. In this paper the author showed from experiments that the Cambrian strata in Wales contain a far greater amount of phosphate and carbonate of lime than had hitherto been supposed. The results published by Dr. Daubeny some years ago, and which have since received the support of some eminent geologists, were proved therefore to be entirely fallacious when taken to represent the whole Cambrian series; for though some portions show only a trace of these ingredients, there are other beds both interstratified with and underlying these series, which contain them in unusually large proportions. The author, therefore, objects to look upon Dr. Daubeny's experiments as tending in any way to prove that the seas in which these deposits had accumulated contained but little animal life, and that we had here approached the borders of the lower limit of organic existence. He contended that the presence of so much phosphate of lime, and also of carbonate of lime, as was now proved by analyses made by Mr. Huddleston, F.C.S., Mr. Hughes, F.C.S., and himself, to be present in series of considerable thickness in the Longmynd group, Menevian group, and Tremadoc group, proved that animal life did exist in abundance in these early seas, and that even here it must be considered that we were far from the beginning of organic existence. The amount of phosphate of lime in some of the beds was in the proportion of nearly ten per cent., and of carbonate of lime over forty per cent. The proportion of phosphate of lime, therefore, is greater than is found in most of what have been considered the richest of recent formations. The amount of  $P_2O_5$  was also found to increase in proportion to the richness of the deposit in organic remains. It was found that all animal and vegetable life had contained it from the very earliest time; but it was apparent that the Crustacea were the chief producers of it in the early seas; and of the Crustacea, the trilobites more particularly. It was always found where they were present, and the shell of some of the larger trilobites, as now preserved, contained as much as from forty to fifty per cent. of phosphate of lime. The analyses made by Mr. Huddleston and the author, of recent Crustacea, proved that they also contain  $P_2O_5$  in very considerable proportions. In the second part of the paper the author showed that where intrusive dykes had passed through or between the beds containing the phosphate of lime, the beds for some distance on each side of the dykes had undergone a considerable change. Scarcely a trace of the  $P_2O_5$  or of the lime was now to be found in them, though it was evident that before the intrusions into them had taken place, they, like the other portions of the beds, had evidently contained both ingredients in considerable proportions. It was well known that heat alone could not separate  $P_2O_5$  from lime; therefore he found it difficult to account for this change in the character of the beds, unless it could be produced by gases or watery vapour passing into them at the time the intrusions took place. He thought it even probable that the dykes, which in some parts are found to contain a considerable amount of lime and also of  $P_2O_5$ , might have derived these, or at least some portions of these, from the beds through which they had been forced, and which must have been broken up and melted as they passed through them. There are no contemporaneous tufts known in Wales of earlier date than the Llandilo beds; and he thought these dykes belonged to that period, and that they

were injected into the Lower Cambrian beds after from 8,000 to 10,000 feet of deposit had been superimposed. In an agricultural point of view the author considered that the presence of so much phosphate of lime in some of the series of beds must be a matter of great importance; and on examining the districts where these series occurred, he invariably found the land exceedingly rich. Mr. Huddleston gave the results of the analyses made by him at the request of Mr. Hicks. He found in a portion of dark gray flaggy rock taken from close to a fossil 1'62 in a portion of black slaty rock containing trilobites, but in contact with trap 0'11, in a portion of the shell of a trilobite 17'05, and in the trap above-mentioned 0'323 per cent. of phosphoric anhydride. A lobster-shell dried at 100° C. gave 3'26, an entire boiled lobster (undried) 0'76, and a boiled lobster without shell 0'332 per cent. of  $P_2O_5$ . If the analysis of an entire lobster be correct, he estimated that a ton of boiled lobsters would contain about 17 lbs. of phosphoric anhydride. In the analysis of a shell of a trilobite there appears to be a great excess of phosphoric acid, which Mr. Huddleston thought must be due to substitution.—Note on the structure of the phosphatic nodules from the top of the Bala Limestone in North Wales, by Mr. Hawkins Johnson, F.G.S. In this paper the author described the appearances presented by thin sections made from some of the phosphatic nodules and shales described by Mr. D. Davies, F.G.S., in his recent paper. In both nodule and shale he finds structure which he is inclined to identify with sponge-structure; but the mass also contains innumerable foreign bodies, chiefly fragments of the shells of Mollusca and Crustacea, with many irregularly ovate bodies that remind him of *Coccinopora*, and some that may be sponge-spicules. The author enumerated fourteen nodular formations from various localities and of various composition, in which he has detected organic structure, and to which he therefore assigns an organic origin; and he protested against the application of the term "concretionary" to such bodies.—On the maxillary bone of a new Dinosaur, *Prodonotognathus Phillipsii* contained in the Woodwardian Museum of the University of Cambridge, by Mr. Harry Govier Seeley, F.L.S., Professor of Physical Geography in Bedford College, London. The bone described in this paper was indicated by the author in his "Index to the Aves, Ornithosauria, and Reptilia in the Woodwardian Museum," under the name of *Iguanodon Phillipsii*. Further examination and the detection of successional teeth resembling those of *Scelidosaurus*, and those referred by Prof. Huxley to *Acanthopholis*, induced him to regard the species as representing a new genus, most nearly related to *Hylaeosaurus*. The specimen consists principally of the external and alveolar portion of the left maxillary bone, which is 4½ inches long, the alveolar part being 4½ inches, and the remainder made up by a posterior spur for connection with the malar. From the middle of the upper margin springs an ascending nasal process, separating the orbit from the nasal aperture. The presence of the posterior spur, or jugal process, seems to indicate an affinity to the Iguanodontidae, notwithstanding the resemblance of the teeth to those of *Scelidosaurus*. The teeth, which are seen in their sockets, have their crowns resembling those referred to *Echinodon*, *Scelidosaurus*, and *Acanthopholis*, especially the last, differing chiefly by being relatively narrower, by having only 5-7 denticles on each side, by wanting the thickening at the base, and by terminating in a sharp point. The author described in detail the characters presented by the fossil, and indicated their bearing upon its systematic position. It was imbedded in a small slab of yellow sandstone, which also contained a specimen of *Pecten vagans*, and is probably of Great Oolite age.—Description of a new species of the genus *Hemipatagus*, Desor, from the Tertiary Rocks of Victoria, Australia, with notes on some previously described species from South Australia, by Mr. R. Etheridge, jun., F.G.S. In this paper the author described a new species of the genus *Hemipatagus*, under the name of *H. Woodsi*, and appended to this description some remarks on the characters of *Psammochinus Woodsi*, Laube, *Micraster brevistella*, Laube, and *Monostychia australis*, Laube; and also a synoptical list of the Australian Tertiary Echinodermata hitherto described.

Physical Society, April 10.—Prof. G. C. Foster, vice-president, in the chair.—Prof. H. M'Leod communicated to the Society some observations on the defects of the human eye as regards achromatism. The eye has been considered to be achromatic because it practically is so; but it is easy to offer abundant evidence of the defects of the organ in this respect. For instance, to short-sighted persons the moon appears to have a blue fringe. In using the spectroscope, the red and blue ends of the spectrum

cannot be seen with equal distinctness without adjusting the focussing glass. A black patch of paper on a blue ground appears to have a fringed edge if viewed from even a short distance, while a black patch on a red ground, when observed under similar conditions, has a perfectly distinct margin. Prof. M'Leod then explained that the overlapping of images in the eye produced the mental impression that there is no want of achromatism. It is interesting to note that Wollaston considered that the coloured bands of the spectrum were really divided by the black (Fraunhofer) lines, and his statement that the red end of the spectrum does not appear to have a boundary line, "because the eye is not competent to converge the red rays properly," shows that he had very nearly, if not quite, discovered the achromatic defects of the eye. Dr. Young ascribes to Wollaston the merit of having observed that when a luminous point is viewed through a prism the blue end appears to be wider than the red, the eye being incapable of recognising that the spectrum has the same width throughout its entire length. An excellent experiment was then exhibited to show the relative distinctness of a dark line on grounds of various colours. A string or wire was so arranged that its shadow traversed the entire length of a spectrum which was thrown on a screen by an electric lamp. When viewed from a short distance the edges of the shadow appeared to be sharp at the red end, but gradually became less distinct, until at the blue end nothing but a blurred line remained. Dr. W. H. Stone considered that the paper was specially valuable as suggesting a possible mode of investigating the relation between the defects in the eye and the personal co-efficient of error in observation.—Prof. Guthrie showed a kaleidoscope, devised by Mr. R. Cowper, in which the usual geometrical effects were produced by fragments of mica illuminated by polarised light.—Mr. Wilson, Demonstrator in the Physical Laboratory, South Kensington, exhibited a modification of Thomson's galvanometer, which might be readily constructed at a small expense. He used two discs of glass and replaced the usual brass quadrants by tinfoil; the connection between the binding screws and the quadrants was effected by fusible solder and platinum wires.—The Vice-President then alluded to the lamented death of Mr. C. Becker, of the firm of Messrs. Elliott, whose loss will be severely felt in every laboratory in this country.

Royal Microscopical Society, April 7.—H. C. Sorby, F.R.S., president, in the chair.—A paper by the Rev. W. H. Dallinger and Dr. Drysdale was taken as read; it was entitled, "Some further Researches upon the Life History of the Monads," and described the results of a number of careful observations made in continuance of the series communicated upon former occasions.—The President read a paper on some contrivances for the study of spectra and for applying the mode of spectrum analysis to the microscope. Having exhibited and explained the improved form of spectrum microscope, the adaptation of the spectroscope to the binocular arrangement, and a new form of diaphragm, the author proceeded to show the meaning of the absorption bands and the various methods of measurement and determination, pointing out the advantages of his new wave-length system over his former plan of comparison with the quartz interference scale. The effects of acid or alkaline additions to solutions were also shown by means of diagrams.

Institution of Civil Engineers, April 6.—Mr. Thos. E. Harrison, president, in the chair.—The first paper read was on the manufacture of steel, by Mr. Wm. Hackney, B.Sc.—The second paper was on Bessemer steel rails, by Mr. Josiah Timmis Smith. The object of this paper was to endeavour, briefly, to show that, with care in manipulation and in selection of materials, Bessemer steel might be produced constant in quality, and that certain inexpensive tests might be applied which would absolutely determine the quality of the material, in most if not all of its characters, so far as was required for railway and structural purposes.

## PARIS

Academy of Sciences, April 5.—M. Frémy in the chair.—The following papers were read:—On a singular case of magnetisation, by M. J. Jamin.—On the theory of aspiration, with remarks on the new note of M. Peslin, by M. Faye.—On the limits of combining carbon with iron, by M. Boussingault.—On some documents relating to the history of diabetes, by M. Andral.—M. van Beneden then presented to the Academy a work on parasites in the animal kingdom.—The Academy then nominated a number of gentlemen to superintend the competi-

tion for various prizes during 1875.—On a scientific balloon ascent of long duration, by MM. Sivel, Crocé-Spinelli, A. and G. Tissandier, and Jobert. This is a detailed account, with several diagrams, of the ascent made by these gentlemen in the balloon *Le Zenith* on March 23rd last. The balloon was 18 metres in diameter, and held 3,000 cubic metres of gas; the scientific observations were made with barometers, thermometers, hygrometers, compasses, telescopes, and spectrosopes. Moreover, they had a fine electroscopie, with a long copper wire of 200 metres, and an apparatus to measure the absorption of carbonic acid. The observers saw a fine lunar halo and six shooting stars, one of which with a long intensely blue trail. Four carrier pigeons were despatched, none of which returned to Paris.—A note by M. Sirodot, on the Mammoth of Mont-Dol (Ille-et-Vilaine).—On the relation between the *m* cyclic periods of the exponent of an algebraic curve of the *m* degree, by M. Max Marie.—Researches on co-variables, by M. C. Jordan.—A memoir by M. H. Durrande, on the applications of the general theories of dynamics to the motions of a body of varying form.—A note by M. Bouty, on the quantities of magnetism and the situation of the magnetic poles in thin needles.—On the physical properties of thin layers of collodion, by M. E. Gripon.—On the formation of iodine acid in flames in which iodine is volatilised, by M. G. Salet.—A note by M. R. Engel, on the substitution of hydrogen by mercury in creatine.—A note by M. Lecoq de Boisbaudran, on the inequality of action of different isomorphous bodies on the same supersaturated solution; account of experiments made principally with potassic chrome alum and ammonia alum.—On a new process of extracting salt from soils, applied in the South of France, by M. A. Joannon. This process renders large tracts of land, which are now lying bare and un fertile, fit for purposes of agriculture.—A note by M. A. F. Marion, on the anatomy of a remarkable species of the group of *Nemerita*, *Drepanophorus spectabilis*.—A note by M. E. Prillieux, on tumours produced on the wood of apple-trees by the *Puccinia lanigère* (a parasitic insect).—A note by M. Dezaudière, on the sounds produced by the heart.—MM. Schnetzer, Pelletreau, Chase, Noddy, Chaperon, and Delfau, then made some communications with regard to Phylloxera.—M. Petrequin then addressed to the Academy several papers on the application of galvano-puncture in the treatment of aneurisms.—A memoir by M. Jaquet, on the use of the tables of Pythagoras for any number.—A note by M. Tridon, on the means of making telescopic observations and obtaining photographic proofs in the inside of an aerostatic diving-bell.—A note by M. Gruy, on the zodiacal light observed at Toulouse in February and March 1875, giving detailed tables of the observations of this interesting phenomenon.—On a method of calculating the absolute perturbations of comets, by M. Hugo Gylden.—On manganese iron from carbonates, by MM. L. Troost and P. Hautefeuille.—Researches on the carbon of white cast-iron, by M. P. Schützenberger and A. Bourgeois.—On the theory of storms, a reply to M. Faye, by M. H. Peslin.—A note by M. Hildebrand Hildebrandsson, on the superior currents of the atmosphere in their relation to the isobarometrical lines.—On a new formula for the calculation of the refractive power (or the number) of convex lenses, by M. Monoyer.—Gen. Morin then presented to the Academy a new part of the *Revue d'Artillerie*, published by order of the War Minister.

## CONTENTS

	PAGE
ROYAL AGRICULTURAL SOCIETY'S JOURNAL, I.	461
COOKE'S "FUNGI"	462
M. H. AND E. MILNE-EDWARDS'S NEW WORK ON MAMMALS	463
OUR BOOK SHELF:—	
Turner's "Human Anatomy"	464
LETTERS TO THE EDITOR:—	
On the "Law of Fatigue" regulating Muscular Exertion.—Prof. SAMUEL HAUGHTON, F.R.S. ( <i>With Illustrations</i> )	464
The "Wolf" in the Violoncello.—W. H. STONE	466
Flowering of the Hazel.—A. W. BENNETT, F.L.S.	466
A Flint Cell.—E. J. A'COURT SMITH	466
Arctic Temperatures.—JOSEPH JOHN MURPHY	467
AERONAUTICS. By W. DE FONVILLE	467
ARCTIC GEOLOGY, II. By C. E. DE RANKE, F.G.S.	467
THE PROGRESS OF THE TELEGRAPHS, III. ( <i>With Illustrations</i> )	470
OUR ASTRONOMICAL COLUMN:—	
The Solar Eclipse of 1900, May 28	472
Winnecke's Comet	473
The Star B. C. 2659	473
THE "TIMES" WEATHER CHART ( <i>With Illustration</i> )	473
THE ECLIPSE EXPEDITION	474
NOTES	474
ACCIDENTAL EXPLOSIONS, II. By Prof. F. A. ABEL, F.R.S.	477
SOCIETIES AND ACADEMIES	478

THURSDAY, APRIL 22, 1875

## THE ANCIENT MONUMENTS BILL

IT is so far gratifying that Sir John Lubbock's bill for the preservation of the few remains of our ancient monuments that time and the ignorant or sacrilegious hand of the spoiler have left, passed the second reading by a respectable majority on Wednesday week. The Committee was fixed for yesterday, and we hope the bill will pass through the ordeal with its main principle and provisions intact. As our readers are doubtless familiar with the purpose and main details of the bill, which has been before the public for three years, it is unnecessary to expound them here, especially as we have already done so in a previous article (*NATURE*, vol. vii., p. 297).

The objections urged against the bill, both in the House of Commons and in the *Times* article of Monday, seem to us either frivolous or inapplicable. They may be all summed up in the statements that the bill interferes with the sacred right of private property, and that it is unnecessary, as private owners and the public generally are fully aware of the value of our historic and prehistoric relics, and that no special provision is required for their preservation.

As to the objection that the bill will interfere with the individual rights of property, we can hardly believe that even those who most strongly urged it really believe that this objection will hold water. Were the bill as it stands passed into law, landowners on whose estates any ancient monuments are situated that the Commissioners thought came under the operation of the Act, would be in exactly the same position to the relics as before, with the exception that they would not be allowed to do anything tending to their injury or destruction. And we hardly think that even any of the honourable objectors to the bill would openly declare that they held the right of destruction of a national monument to be one of the rights of private property. Nearly all the objectors expressed their respect for the remains left behind by the previous populations of this country, and their anxiety that no harm should come to them; and this the bill proposes to accomplish in a way that cannot possibly be done so long as these monuments are the absolute property of private individuals.

For the opponents of the bill in Parliament, as well as the *Times*, may talk as they will of the public spirit of the country being a sufficient safeguard against the ruthless destruction of these relics which all but the lowest class of philistines must regard as precious; but there is no doubt whatever that for want of a provision such as that contained in the bill, many of the most valuable of our ancient monuments have suffered grievous and irreparable harm. No more forcible instance could be adduced than that of "Cæsar's Camp" at Wimbledon, which, under the eyes of the public, and by members of that public whose "spirit" is so much lauded, is being rapidly obliterated from the land. No one can at present prevent it. And over all the country there are remains of equal value whose preservation it is nobody's business to see to, and which therefore, by destructive time, by philistine tourists and owners, or ignorant farmers and peasants, are gradually being made to share the fate of Cæsar's Camp. Had such a bill been passed a century or even half a century

ago, how much valuable material might have been saved to the student of history and antiquities, to the investigator into the progress of civilisation and of the human race!

The *Times*, for some inscrutable reason, has seen meet to oppose the bill to a great extent on practical grounds, as if its purpose were to preserve every relic of the past that might come to light, no matter at what expense to the public welfare and convenience. But the writer of the article either ignorantly or wilfully mistakes the purpose of the bill altogether; we believe that all the monuments enumerated are so situated, are at such a distance from the "busy haunts of men," that their preservation neither now nor at any future time is likely to interfere with the convenience and welfare of the existing population. It is simply stupid to speak in this connection of fragments of old walls and tessellated pavements unearthed in London; Sir John Lubbock himself, we believe, and those who support the bill, would have no hesitation in sweeping away any ancient monument whatever, if it could be really shown that it stood in the way of the progress of the country and the race. But in the *Times* article there is an unmistakable inclination to doubt the "utility" of taking any care at all to preserve the monuments left by our predecessors; the writer evidently cannot see that it serves any "practical" purpose. Not even any of the opponents of the bill objected to it on this score. The objection is similar to that which the same paper urged against the Arctic Expedition, and might with equal force be urged against every undertaking and every pursuit that had not some unmistakable so-called "practical" end immediately in view. Were such a principle to have sway, then all science might be "thrown to the dogs;" but it is too late in the day to bring it forward: and with regard to our ancient monuments, we feel sure that all the intelligent portion of the nation would revolt were it proposed to take no further care of them, but allow them either to crumble or be carted away. There is no security against such a fate for them unless by some such enactment as that which the bill proposes. And, after all, we believe that the *Times* itself would advocate the preservation of even a fragment of tile, if it could be shown that it would in any way conduce to the highest good of the race.

Sir John Lubbock's reply to the objections urged in the House of Commons is so admirable and so much to the point, that we shall conclude by giving it almost entire. There is a certain touch of well-deserved scorn in his remarks upon some of the trivial objections which were brought forward.

"It would not be denied by anyone," he said, "that our ancient monuments were gradually disappearing, victims of the increased value of land and the demand for road material and building stones. Now, he asked hon. members to look at the ancient monuments in their own districts mentioned in that bill, and tell him which of them they would see destroyed without regret. Was it Silbury Hill, the grandest sepulchral monument, perhaps, in Europe? Was it Avebury, the most remarkable of the so-called Druidical structures? Was it Stonehenge, enigmatical and unique? Was it Arthur's Round Table, or the Rollrich stones, Kitscoty House, or Wayland Smith's Forge, dear to all readers of Sir Walter Scott? Or, turning to Scotland, was it the curious Dun of Dornadilla? Was it the Burgh of Moussa, the only one, he believed, mentioned in the Sagas, and which is even now nearly perfect? Was it Sueno's Stone? or the Cats

Stane, with its inscription said to be in memory of Vetta, the son of Hengist? Was it the Newton Stone, with its inscription as yet altogether unread? Was it Maeshowe, with its runic records? or the Ring of Brogar? or the Stones of Stennis, with all their romantic associations? In Ireland, was it the Giant's Ring, near Belfast? Was it the curious fortification known as Staigue Fort? Was it the remarkable tumulus of Newgrange, with its curious decorations? Was it the ruins of Teltain, or the remains of the hill of Tara associated so intimately with the earliest of Irish records? He hoped that the bill would be rejected neither by Englishmen nor Scotchmen; and Irishmen surely would not grudge a slight and almost infinitesimal expense for the preservation of these fragments of early Irish history. Indeed, the expense entailed by the measure would be very trifling; the amount, moreover, would be settled by the Treasury and controlled by the House of Commons. Those monuments had passed through great dangers. They had been spared by Roman soldiers, by Britons, Saxons, Danes, and Normans; they were respected in days of comparative poverty and barbarism; in these days of enlightenment and civilisation, of wealth almost beyond the dreams of avarice, they were in danger of being broken up for a profit of a few pounds or removed because they cumbered the ground. If the House allowed them to be destroyed, they could never be replaced. It was said that the bill would interfere with the rights of property. What rights? The right of destroying interesting national monuments. That was the only right that would be interfered with. It was not incidental to the bill, it was no drawback in the bill, it was the very object of the measure. It was really, however, the rights of destruction, not the rights of possession, which it touched. It was now for the House to determine whether it would exercise on behalf of the nation the right to preserve those monuments; whether it would maintain the right of individuals to destroy, or the right of the nation to preserve. He hoped the House would agree to the second reading of the bill, for it would surely be a shame and a disgrace to allow those ancient monuments to perish."

We are sure Parliament, if it passes the bill in its entirety, will have not only the approval of the nation, but the admiration of educated men all the world over.

#### PRACTICAL PHYSICS

*Introduction to Experimental Physics.* By A. F. Weinhold, Professor in the Royal Technical School at Chemnitz. Translated and edited by B. Loewy, F.R.A.S. With a Preface by Prof. G. C. Foster, F.R.S. (London: Longmans, 1875.)

IN English schools of the present day the teaching of Experimental Physics is, with few exceptions, either neglected or abused. Yet there can be little doubt that this subject ought to be an integral part of the secondary education of every boy and girl. Its usefulness merely as knowledge that touches us at every point in daily life, and that finds its development intimately associated with many modern trades and professions, is a tangible argument in its favour. But it is as a means of education, rather than as a vehicle of instruction, that physics should be taught in schools. And this because of its high power—when properly taught—of educating individual judgment, by training the senses to habits of accurate observation and the mind to clear and precise modes of thought. Added to all this, practical physics confers the benefit, by no means to be lightly regarded, of giving to the hands the power of useful skill.

Prof. Foster well remarks, in his excellent preface to the work before us: "In the study of physics we are obliged not only to learn a large number of new facts, but also to adopt new habits of learning; while we have at the same time to accustom ourselves to attach accurately defined meanings to the terms employed in discussing physical phenomena, and to reason about them with mathematical strictness, and often by the help of technical mathematical methods. These characteristics of the study of physics give to it a value, as a means of training in habits of exact thinking, which probably no other study possesses in the same degree; but at the same time they make this study more than usually difficult, especially to beginners."

It is this felt difficulty, no doubt, that largely contributes to the exclusion of physics from the general curriculum of our schools and colleges. And where physics is introduced, it is, we fear, too often badly taught, for its method of teaching is misunderstood. It generally proceeds upon the old lines of the black board and textbook. Nor is this to be wondered at. For if a schoolmaster be really anxious to teach experimental physics thoroughly, he is staggered at the multiplicity and cost of the apparatus involved, and out of this difficulty our text-books have hitherto shown him no way of escape.

Where experimental science is honestly attempted, chemistry is found to be less formidable; it also abounds in useful practical class-books, and so this subject is far more widely taught than physics. To many parents and schoolmasters chemistry has become the embodiment of all their thoughts of science. Fumes, explosions, and mess, are, to a large section of the public, inevitably associated with their idea of natural knowledge in general, and experimental knowledge in particular. The replacement of physics by chemistry in schools is much to be regretted on educational grounds; for, so far as the present writer's experience goes, it is decidedly adverse to making chemistry the first or chief part of the scientific training of youth. Nor is there much likelihood of seeing experimental physics generally taught in schools until there are good text-books on practical physics that will enable the student to construct his own apparatus as he proceeds.

On these grounds chiefly we are glad to welcome the present translation of Prof. Weinhold's "Vorschule der Experimental Physik." By following the full and excellent directions given by Prof. Weinhold, any intelligent lad can be his own instrument maker; and besides the pleasure of construction, he will acquire a sound and extensive acquaintance with the elements of physics by the time he has carefully gone through the book.

Knowledge thus obtained will be ineffaceably written on the memory, and its worth will be far greater than a corresponding expenditure of time spent in merely reading several of the ordinary class-books. Nor can there be any doubt, as Prof. Foster says, that "whenever this or some similar work comes to be commonly adopted in schools, physics will be in a fair way of becoming one of the most popular as well as most useful parts of school-work, instead of being, as it too often now is, less liked and worse taught than almost any other subject."

One great merit of Prof. Weinhold's hand-book is its great detail. Nothing is more provoking than the vague

generalities and assumptions found in the general run of physical treatises, so that the student is left in the lurch just at the critical moment when he most needs help. It is quite refreshing to notice the minute care with which Prof. Weinhold describes the construction of each piece of apparatus. As illustrations of this take the instructions for cutting glass on p. 14, for soldering on pp. 27 and 28, for cutting screws on pp. 93 and 94; and especially valuable are the directions for making various simple forms of binding screws given on pp. 656-660. Every woodcut

is drawn to scale, every bit of apparatus employed has its dimensions given, every difficulty is pointed out, and failure thus made almost impossible.

Nor is this work only useful for science students. We venture to say any intelligent boy of twelve to fourteen years old might begin this book by himself, and, steadily working at it out of school hours and during the vacation, would in twelve months' time have not only mastered its contents, but have made for himself a very respectable and thoroughly useful collection of physical apparatus, the

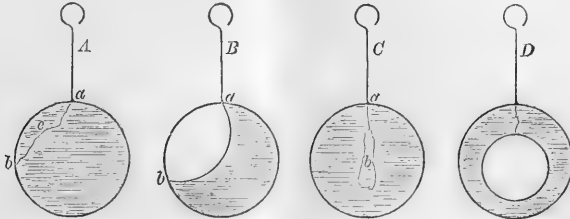

FIG. 1.—Experiments in liquid films.

history and meaning of every fragment of which will be known and loved as part of his nature.

But we shall be doing Prof. Weinhold more justice if we give our readers a few extracts from his hand-book. Here, for example, is a simple and elegant method of demonstrating the tension of liquid films. A ring is dipped in soap solution contained in a flat saucer, and then withdrawn; a film is thus formed after the manner of Plateau's experiments:—"If a very fine silk thread,

the film will always stretch it so as to form an arc of a circle. If a small loop is made at the end of the thread, (Fig. 1, C, D), the latter fixed at *a*, and the film broken at *b*, the thread of the loop will form a complete circle within the ring."

In speaking of hydrostatic pressure, the following simple arrangement is described:—"A pig's bladder, or, better still, that of an ox, is cut down near its mouth so far that the end of a glass tube of about the thickness of a finger, and ten centimetres in length, may be passed through the aperture and firmly tied (if necessary with the help of a cork). A longer glass tube is connected with the shorter by a piece of tight-fitting indiarubber tube, and held in a vertical position by the fork of the retort stand. The bladder is moistened, placed upon the table, flattened out as much as possible, and a piece of board, such as the lid of a box or a drawing-board, laid upon it, so that the bladder is not in the middle, but close to the edge of the board. At each end of the bladder small blocks of wood about two or three centimetres high are placed, in order to protect the glass tube, which reaches under the board, from being broken by the pressure of the board and the weights to be afterwards placed upon it. By pouring water from a bottle or through a funnel into the tube, the bladder is filled until the board begins to rise above the blocks and is in contact with the table only along one edge."

There is a neat illustration of the work done by falling bodies on p. 74, but the author is evidently unacquainted with Prof. Ball's admirable manual on experimental mechanics, wherein the student will find mechanical problems more rigidly and amply put to the test of experiment.

The section on Sound, we observe, omits all reference to the beautiful demonstrations which can be given of the reflection and refraction of sound, nor is there a single reference to the subject of sensitive flames, the value of which as phonoscopes should, in our opinion, hardly have been overlooked. The following simple method of making Kœnig's gas-flame manometer is given on p. 395. For



FIG. 2.—Weights raised by liquid pressure.

wound from a cocoon, is tied to two points of the ring *a* and *b* (Fig. 1, A, B), and the film which is formed be broken within the portion *c*, by the finger or a rolled piece of blotting-paper, the unbroken portion of the film will contract and stretch the thread into a beautiful curve. If the thread be fixed only at *a* and held by the finger at *b*, its length may be altered at will, but the contraction of



the ordinary wooden capsule a large cork is substituted. "It is cut across the middle, the necessary holes are bored in it for the tubes, and a conical cavity is cut into each half with a sharp penknife, as shown in Fig. 3. Large corks are never quite air-tight; the whole of the outside should therefore be covered with a layer of sealing-wax one or two millimetres thick; this is done after the two halves have been glued together and the whole is perfectly dry." Before being glued together, a piece of goldbeater's skin is stretched between the two halves at *h*. The tubes *abc* are of glass, the aperture of

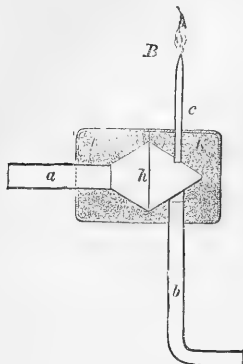

FIG. 3.—The Flame Manometer.

*c* being about 0.4 mm. Here we may observe that, instead of goldbeater's skin or collodion film, which students in general will find difficult to procure, a portion of one of those children's toy balloons made of thin india-rubber may be substituted with great advantage. It should be attached as follows: the edge of the capsule is first glued, and the inflated balloon then pressed on it; when the glue is dry, the portion that remains attached to the capsule is cut round with a knife; by this means a tense thin film is strained across the instrument.

These toy balloons will be found of frequent service in acoustics.

The useful little instrument just described will therefore cost little beyond the slight trouble of making it. Nevertheless, the English editor has permitted a firm of instrument makers to advertise it for half a guinea at the end of the volume as "an indispensable piece of apparatus required by the student of this work." In like manner it is "indispensable" to buy a Barker's mill, the price charged being a guinea, when on p. 201 the student is shown how to make one for twopence. We might quote several other instances from this carelessly inserted advertisement. As a translator Mr. Loewy seems to have done his duty

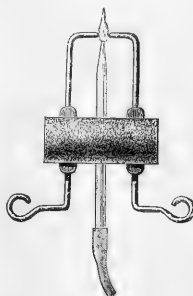

FIG. 4.  
Heating effects of the discharge in Leyden jar.

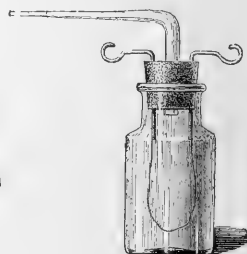

FIG. 5.

well, but we would suggest the necessity of his exercising a little more editorial care if a second edition of this work is called for.

In the section on Light there are some capital instructions for making concave and convex mirrors, and for constructing a simple form of spectroscope, which is entirely built up by the student. The manufacture of a bisulphide of carbon prism (employed in this spectroscope) is always a matter of difficulty. Prof. Weinhold recommends making the body of the prism of a lamp cylinder cut to a wedge shape by an ignited pastille; the

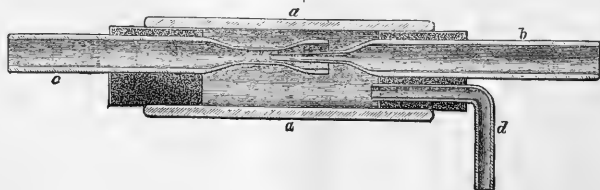

FIG. 6.

edges are then ground with emery powder, a hole bored for filling the prism, and the sides of plate-glass (French plate should have been stated) cemented on by a mixture of glue and treacle.

The accompanying woodcuts indicate two simple arrangements for showing the heating power of the electric discharge. In the one case (Fig. 4) wires, bent as shown in the figure, are insulated by sealing-wax and passed through a cork, in the centre of which is a glass tube allowing a gas jet to issue between the wires, the

gas being ignited on the discharge from an electrophorus between the points. The other apparatus (Fig. 5) shows that even good conductors are heated by the electric discharge. "A small wide-necked glass bottle is closed by a cork, through which two wires pass and also a glass tube, which is drawn to a point about 1.5 mm. wide, and bent horizontally. The wires are connected by a long, very narrow strip of tinfoil. The glass being very slightly warmed by holding it in the hand for a moment, a drop of water is brought upon the point of the tube.

The heat produced by the passage of the spark through the strip of tinfoil is sufficient to expand the air in the bottle again, and the drop of water is pushed outwards by the expanding air through a space of one or several millimetres."

Fig. 6 is a simple form of the so-called "injector" or steam-jet pipe for feeding the boilers of steam-engines. A glass tube, *aa*, has corks fitted at each end into which pass the tubes *cc d*. Steam issues from the small aperture in *b*, and expanding passes out into the air through *c*. The air within *aa* becomes rarefied, and the water into which the tube *d* dips is thus driven by atmospheric pressure into, and finally ejected from, *c*.

"The construction of the little injector presents no difficulty, but the dimensions of the various parts must be exactly those shown in the figure, if the action is to be depended upon. Each side of the right angle into which the jet tube is to be bent should be about 3 cm. long, and the tube as wide as *c*; the pointed end should be like that of *b*, or very little narrower. An india-rubber suction-tube, 10 or 15 cm. long, may be attached to *d*. The india-rubber tube employed for connecting the apparatus with the vessel in which the steam is generated should fit very tight; it must not be tied with thread, so that in case the pressure of the steam becomes too great, the india-rubber may be forced off the glass tube, instead of its being torn or the glass broken by the pressure."

Before closing the volume, we notice one or two places, besides those previously alluded to, in which a little improvement might be made. For example, in describing the construction of the gold-leaf electroscope, the mode of cutting gold leaf is omitted. The author recommends students "to have the strips cut and fixed to the flat end of a wire by a skilled mechanician." This is unsatisfactory, for students cannot have recourse to a skilled workman when they like. Nor is there any very great difficulty about cutting and fixing the gold leaves when the proper method is patiently tried. Here, as throughout all practical work in physics, perseverance is the essence of success. Again, we observe that useful little instrument the "carrier," or proof-plane, might be more readily made than is stated here. The simplest plan is to procure an ebonite penholder, and fasten a disc of gilt paper at the end intended for the pen. These penholders are most useful adjuncts to a physical laboratory.

Further on, radiant heat receives rather meagre treatment. There is no description of any form of air-thermometer, an instrument which in a modified shape is capable of doing most useful work through the whole subject of heat. Nor is the subject of magnetism so fully treated as we should have expected; and in current electricity some description should have been given of the measurements of resistance and electromotive force: a simple form of Wheatstone's bridge—such, for example, as that suggested by Prof. Foster—can readily be made, and is indispensable for the proper study of this subject.

But the work is intended as an introduction to the study of physics, and, as such, it is altogether the best we have yet met with among English hand-books. The volume unfortunately is of an unwieldy size, and might have been made far more convenient for the constant reference it requires if a better arrangement of type had been adopted.

W. F. B.

### DRESSER'S "BIRDS OF EUROPE"

*A History of the Birds of Europe, including all the Species inhabiting the Western Palaearctic Region.* By H. E. Dresser, F.Z.S., &c. (Published by the Author, by special permission, at the Office of the Zoological Society of London.)

THE issue of Parts 35 and 36, completing the third volume, affords us the occasion of again noticing the progress of this beautiful and important work.

The energy with which the author has laboured to ensure punctuality in the issue is beyond all praise; and now that about half the work is completed, and we find that the last twelve parts, with figures of nearly 120 species of birds, have appeared within the year, subscribers have every assurance that they will, in due course, possess a finished work.

And this punctuality of issue is not effected by any haste or carelessness of workmanship either in the plates or the letterpress. In the last double number we find some pictures which are triumphs of artistic skill. Such in particular is the figure of the Night-jar (*Caprimulgus europæus*), in which the downy softness of the plumage, the exquisite mottling of the feathers, the roundness and repose of the whole bird, the half-closed sleepy eye, and the well-contrasted background, are exquisitely rendered. The Wryneck (*Yunx torquilla*) is almost equally good, and the tail of this bird in particular is rendered with a delicacy and skill which cannot be surpassed. Another charming picture is that of the Smew (*Mergus albellus*), surrounded by half a dozen young, whose various attitudes and the grouping of the whole, with the quiet river scene, are in admirable taste. The two Sand-martins (*Cotyle riparia*) perched on bending reeds form another beautiful bit of nature. An important feature of this work is the care taken to figure the birds in all their different states of plumage, and more especially that of the young or nestling birds. In this part we have four species in which the young are figured—the Black-winged Kite, the Pied Flycatcher, the Dottrell, and the Smew—and in every case the plumage of these infants is remarkably different from that of their parents. The introduction of these young birds adds greatly to the variety and interest of the plates as mere pictures; but they also have a high scientific value, since they are with good reason believed to indicate what was probably the plumage of the ancestral form of the group to which they belong. From this point of view, the young are really very old birds indeed, and may, when thoroughly studied, enable future ornithologists not only to reconstruct the forms, but also to reproduce the colouring of the birds of past ages. They thus, to some extent, make up for the deficiency of fossil remains of birds; and this work, when completed and the plates arranged in systematic order, will be invaluable to the philosophic naturalist.

It is difficult to choose an extract which shall give any adequate idea of the valuable scientific matter to be found in the letterpress. The following passage (somewhat condensed), taken from the account of the Night-jar, touches on a difficult question which the observations of some of the readers of NATURE may help to clear up:—

"The Night-jar feeds on moths, beetles, and insects of various kinds, most frequently capturing its prey on the wing, its capacious gape forming an excellent moth or

beetle trap. That it eats caterpillars is also certain; but it feeds more especially on the larger insects, such as may-bugs, dung-beetles, large night-flying moths, especially the Sphinx Moth, and various species of nocturnal insects. It is a very greedy feeder, and in the autumn is often very fat. The indigestible portions of the insects it devours (which it swallows entire) it throws up in long pellets, which may frequently be found in the places where it reposes during the day. As it feeds more especially on those insects which are to be met with amongst the dung in places where cattle have been feeding, or where they are stalled, the Night-jar is often to be met with in these pastures or in the immediate vicinity of outlying folds; and hence the popular delusion that it sucks the goats hanging on to their udders; and from this belief has arisen the common appellation of Goat-sucker.

"This species has the claw of the middle toe furnished on the side with pectinations forming a sort of close-toothed comb; and the use made of this peculiar appendage has puzzled naturalists not a little. Some observers contend that it is used to clean the bristles at the base of the bill from the fragments of wings of insects which may adhere to them; but this cannot well be the case, as these vibrissæ or bristles are large, strong, and placed at some distance apart, whereas the teeth of the claw are thin and very close. Others think that as the bird invariably perches along a branch in a direction parallel with it, and never across the bough like almost all other birds, this pectinated claw may assist it in keeping its perch more firmly than it otherwise would do. Other naturalists, again, contend that it is used to hold large insects with greater security; but it appears that the Night-jar almost invariably takes its prey with the mouth and not with the foot; and consequently this supposition falls to the ground. An anonymous writer suggests that the comb-like structure of the claw may be used for disengaging the hooked feet of beetles from the bill, to enable the bird to swallow them; and this may possibly be the case, as the serrations are well calculated to catch the polished limbs of beetles. Anyone who has attempted to confine *Dytisci* or *Scarabæi* in a collecting-box, must be aware of the difficulty in getting their feet free from the edge, to which they hold with the greatest pertinacity, one foot being no sooner pushed in than another is protruded."

This last explanation seems the most probable one, and it agrees with the observation of Gilbert White (of Selborne), who states that he has distinctly seen the Night-jar raise its foot to its mouth while hawking for insects on the wing.

The passage above quoted is a portion of seven quarto pages devoted to an account of the habits and distribution of the Night-jar. A work like the present, so beautifully and artistically illustrated, and of which only a limited number of copies is printed, is sure to become scarce and to rise considerably in value. Lovers of nature and of art may therefore be reminded, that in becoming subscribers they are not only obtaining a valuable and most interesting book, but are at the same time making a profitable investment. A. R. W.

#### OUR BOOK SHELF

*The Monthly Journal of Education and Scholastic Advancement.* A medium of intercommunication for Masters, Mistresses, and others interested in Education. Nos. 1 to 16. (W. P. Nimmo, 1874, 1875.)

The original *Quarterly* form of this journal had been for some years "slowly but steadily increasing in circulation." The journal is now issued as a *monthly* publica-

tion "by a number of teachers who are anxious to be of service to their fellow-workers, and to all persons interested in education." The editor and principal contributors to the two forms of the journal being the same, as might be expected there is no great difference in the earlier and later volumes, but yet there is, we believe, an improvement on the side of the present series. The advantage of such a frequent issue is pretty obvious, but the meeting the subscription for twelve numbers instead of four, is to some a serious consideration. The number of subscribers, we find, is fairly satisfactory, but to make it more than a barely paying matter a much larger number of subscribers, the editor states, is required.

Glancing rapidly over the articles in the numbers before us, we just indicate a few which strike us as most generally interesting. The first we light upon is a letter from Mr. Wilson, of Rugby, to Dr. Temple, on *Successive & Simultaneous Instruction*: it was written in January 1869, and in considering the problem of education advocates the "stratification of studies." The question is naturally discussed with an eye to Rugby, but the paper is, as might be supposed, deserving of careful study by outsiders. Another Rugby master, Mr. Kitchener, gives his views on teaching botany to junior classes; and Mr. J. Clifton Ward on natural science teaching in schools. A paper on trifle blindness advocates Dr. Liebrich's views. Besides, we note a reprint of a paper by Dr. Hodgson, on exaggerated estimates of reading and writing; one on French accent; and one, by Dr. Jones, on Mr. Todhunter's essay on *Elementary Geometry*. These two should be read by all who may wish to see what can be said for and against Euclid as a school textbook of geometry. A portion of each number is devoted to correspondence, and a new feature in this new issue of the journal is a *Mathematical Column*. What the journal wants is the support and contributions of more of our foremost educationalists, and then it would take a higher position than it does at present.

#### LETTERS TO THE EDITOR

[The Editor does not hold himself responsible for opinions expressed by his correspondents. Neither can he undertake to return, or to correspond with the writers of, rejected manuscripts. No notice is taken of anonymous communications.]

#### On the Dynamical Evidence of Molecular Constitution

I BEG to offer the following remarks upon the extremely valuable and instructive lecture by Prof. Clerk-Maxwell which appeared in *NATURE*, vol. xi. pp. 357, 374, in the hope that they may tend to the further elucidation of this interesting subject.

If two bodies are attracted towards each other by a force which varies inversely as the square of the distance, and  $R, r$ , be the force and distance at any instant,  $Rr$  will represent the sum of that portion of the energy of the two bodies which is due to their mutual attraction (he mean being  $\frac{1}{2}Rr$ ); that is, the amount which would be converted from potential to actual energy while they approached each other to this point from an infinite distance.

The sum of the virials  $\Sigma \frac{1}{2}Rr$ , or  $\Sigma(Rr)$ , will therefore represent, for a gas whose molecules are so attracted, the total amount of the energy due to attraction.

According, therefore, to the formula of Clausius, the elasticity of such a gas would be the same as if those forces and a portion of the kinetic energy of translation of every particle equal to the energy which is due to them had no existence.

And as the distances between the particles vary inversely as the cube root of the density, if the attractive forces vary inversely as the square of the distances,  $\Sigma \frac{1}{2}Rr$  will vary directly as the cube root of the density. The deduction from the element of  $\frac{1}{2}Rr$  represented by  $\frac{1}{3}T$  will therefore vary as the cube root of the density, and the value of  $\frac{1}{2}Rr$  will diminish as the density increases.

If the attractive forces vary in a higher inverse ratio, this effect will be further increased.

And if this ratio be the  $n$ th power, the sum of the virials will

be the energy due to the attraction of those forces multiplied by  $n - 1$ , and for a given quantity of gas will vary as the density raised to the power of  $\frac{n-1}{3}$ .

The sum of the virials due to gravitation does not appear sufficient to account for the observed effects, and moreover would vary with the quantity of gas in a compound ratio. We must conclude, then, that the ratio of the force to the distance is a higher one than that of the inverse squares.

Upon that law, as already stated, the sum of the virials would increase, for equal quantities of gas, in the ratio of the cube root of the density. Prof. Maxwell has shown that for equal volumes the increase must be as the square of the density, that is, for equal quantities as the density. In order to obtain the same result directly, supposing the density to vary, the quantity remaining constant, it is necessary to assume the forces to vary inversely with the fourth power of the distances. On this supposition the sum of the virials will vary for a given density, as the facts appear to indicate, directly with the volume.

The formula of Clausius does not elucidate the phenomenon of the increase of  $\beta V$  at low densities with increase of density, experimentally demonstrated in the case of hydrogen gas only, but probably true, as conjectured by Regnault, of other gases also at sufficiently high temperatures.

The rationale of this I believe I have discovered, but will not now attempt to enter upon this point.

Prof. Maxwell mentions that Clausius had long ago pointed out that the ratio of the increment of the whole energy to that of the energy of translation may be determined if we know by experiment the ratio of the specific heat at constant pressure to that at constant volume.

The same result is obtained by comparing the specific heat at constant volume with the difference in the kinetic energy of translation on increase of temperature indicated by the increase of pressure; a method by which a small error arising from the variation in the value of  $\beta V$  at different densities is eliminated, the sum of the virials remaining constant.

Taking  $c_1$  to represent the specific heat at constant volume,  $J$  the mechanical equivalent of heat,  $\beta$  and  $V$  the initial pressure in pounds per square foot and volume in feet of a pound weight of the gas,  $T_0$  and  $T_1$  the energy exclusive of that of translation at zero and  $T_1$  Centigrade respectively, a the coefficient of expansion for constant volume,\* we shall have—

$$c_1 J - \frac{3}{2} a \beta V = T_1 - T_0.$$

For atmospheric air  $c_1 J$  may be taken at 233'41, and  $\beta V$  at 26215, and  $a$ , by Regnault's experiments, is '003665, so that—

$$T_1 - T_0 = 233'41 - 144'12 = 89'29.$$

This gives the increment of energy due to other motions than that of translation not quite two-thirds of that due to the motion of translation. The exact ratio is 1'859 to 3.

The experiments of Regnault prove that neither  $\beta V$  nor  $a$  are absolutely constant at all densities. He found  $a$  at '1444 atmosphere to be '0036482 and 4'81 atmosphere '0037091. His experiments do not indicate an appreciable difference in the value of  $\beta V$  between '1444 and 1 atmosphere, but between 1 and 4'81 atmosphere it appears to be diminished about '004 of its amount. The value of  $\frac{3}{2} a \beta V$  in the former case will therefore be about 143'46, and in the latter 145'27.

Supposing the specific heat to be independent of density, this would indicate that the ratio of the increment of the energy of translation to that of the remaining energy, and therefore probably that of the energies themselves, increases with the density. It is, however, not improbable that  $c_1$  may likewise vary, and that the ratio of the two elements may be constant.

M. Regnault's experiments to determine the specific heat of air were all made at somewhat high pressures, varying at the commencement of the experiments from 4 to 6000 mm., and at the termination from 800 to 3000 mm. They more nearly correspond, therefore, to a pressure of 4'81 atmosphere than to 1 atmosphere. And if  $\frac{3}{2} a \beta V = 145'27$ ,  $T_1 - T_0 = 88'14$ , a ratio between the elements of the energy of 3 to 1'82.

It is also probable that  $c_1$  varies to some extent at different temperatures, but I am not aware that any experiments have

\* The coefficient of the increase of pressure, the volume remaining constant, as well as the coefficient of expansion properly so called, is termed the coefficient of expansion by Regnault. In view, however, of the variation which exists from the law of Boyle and Mariotte, it is necessary to observe the distinction.

been made to ascertain this. Regnault throughout assumes the specific heat to be constant for all temperatures.

Prof. Maxwell states that a consequence of Dr. Boltzmann's theorem is that the temperature tends to become equal throughout a vertical column of gas at rest. He also confirms this doctrine as an independent conclusion of his own.

It is with great diffidence that I advance a different view from that which has the sanction of such high authority.

It seems obvious, however, that the mean energy of the molecules moving downwards must be increased, and that of those moving upwards diminished, by the amount of the work of gravitation. And there is nothing to counteract this tendency unless there is repulsion between the particles; attraction would increase it. At all parts of the system there is exchange of energy between the particles; but, supposing equilibrium to have been attained, the mean amounts of energy transmitted in opposite directions at any given point must be equal. Equilibrium, therefore, can only exist when the difference of the actual energy at different distances from the centre of attraction is the same as the difference due to the transfer of particles from one distance to the other.

I think that the equality of temperature must be involved, either explicitly or implicitly, in the data from which the theorem of Boltzmann is deduced.

If this reasoning is correct (supposing the gas at rest), the following equation will represent the relation of the temperatures at different elevations:—

$$t_1 = t_2 - \frac{x_1 - x_2}{c_1 J}$$

where  $x_1, x_2$  are the heights,  $t_1, t_2$  the corresponding temperatures.

The difference of temperature which would exist in the atmosphere at different heights in consequence of this law (one degree Centigrade for every 233 feet) is partly counteracted by the action of the currents; the rate of cooling by expansion being less for the same difference of height. But in a long-continued calm the increase of heat in the lower region of the atmosphere is well known to be intense.

If the condition of equal temperature at all heights were one of atmospheric equilibrium, it would be one of stable equilibrium. It would sooner or later be attained, and would be subject to little disturbance. But the equilibrium which the law above stated tends to induce in still air is extremely unstable, inasmuch as a body of air which has risen in consequence of being warmer and lighter than the surrounding portions of the same stratum has a still greater difference of temperature from the higher strata, having suffered less refrigeration from expansion than that due to the difference of elevation in still air. Slight affections of temperature are therefore capable of causing great atmospheric disturbances, and the tropical calms before alluded to are commonly followed by the most violent tempests.

Prof. Maxwell observes that a molecular æther would be neither more nor less than a gas. This statement requires one qualification, as the theory does not necessarily imply the existence of either attraction or repulsion between the particles, and from the universal diffusion of the æther it must be inferred that no such forces exist. This constitutes a difference of some importance from the condition of a gas. It is true that an equilibrium of temperature would tend to establish itself between the agitation of the ordinary molecules and those of the æther. But the establishment of such an equilibrium would be constantly counteracted by the rapid transmission of the energy communicated to them, through space, by the molecules of the æther; in other words, by radiation. There are doubtless difficulties in this hypothesis, but its rejection involves the conception of the transmission of energy by other means than the motion of material particles, and we have no sufficient ground for supposing any other mode of transmission to be possible.

It has been suggested that the alternative to the conception of a molecular æther is a continuous material substance, not made up of parts, and that such a substance might be capable of motion and of transmitting energy. But a continuous material substance, not made up of separate parts, capable of internal motion, and permeable throughout by ordinary matter, can hardly be called material in an ordinary sense. I find it as difficult to conceive such a substance as an immaterial substance capable of transmitting energy. But I am profoundly conscious of the difference between the limits of our powers of conception and the limits of possibility.

On the "Law of Fatigue" regulating Muscular Exertion \*

## II.

WITH regard to Mr. Nipher's new series of experiments published in NATURE (vol. xi, p. 276), in Table II., I shall make only two observations:—

1. That they appear to me to be subjected to too much of reduction and discussion, a process which does not always improve experiments, and that the intervention of an assistant who lifts the weight from the experimenter appears to introduce new sources of error, both as regards the work done and the punctual observance of time of lift.

2. That the formula (cubical hyperbola) objected to by Mr. Nipher, which is derived from the "Law of Fatigue," represents his new series of experiments quite as well as the complicated empirical formula which he has employed, and which has no theoretical meaning.

I simply give the following table, taken from Mr. Nipher's Table II., and calculated from the formula—

$$n(w + a)^2 = A$$

where  $A = 469.2$ ,  $a = -1.276$ .

Comparison of Nipher and Haughton's Calculations with Nipher's Observations.

$w$	$n$ (obs.)	$n$ (calc.) Nipher.	$n$ (calc.) Haughton.	Diff. Nipher.	Diff. Haughton.
2½	283	242	313	+ 41	- 30
3	152.5	150.3	157	+ 2.2	- 4.5
3½	95.8	99.4	94.7	- 3.6	+ 1.1
4	67.2	69.2	63.3	- 2.0	+ 3.9
4½	51.2	50.1	41.5	+ 1.1	+ 6.1
5	36.9	37.4	33.8	- 0.5	+ 3.1
5½	28.6	28.7	26.2	- 0.1	+ 2.4
6	22.7	22.5	21.0	+ 0.2	+ 1.7
6½	18.1	18.0	17.2	+ 0.1	+ 0.9
7	14.5	14.6	14.3	- 0.1	+ 0.2
7½	10.4	11.9	12.1	- 1.5	- 1.7
8	7.7	9.9	10.4	- 2.2	- 2.7

I also give a diagram (No. 3), showing to the eye the agree-

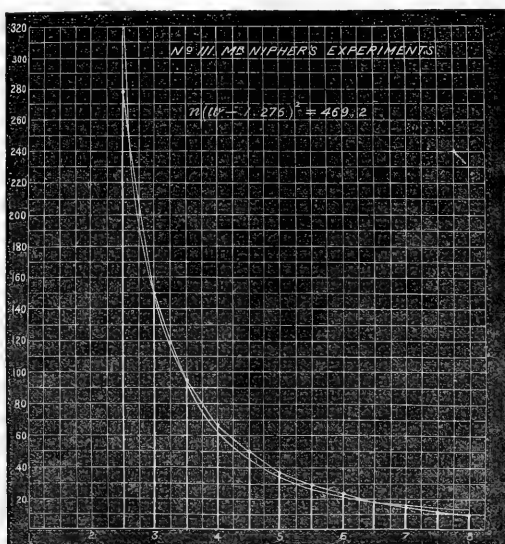

ment between the shape of the cubical hyperbola and Mr. Nipher's observations. In fact it is plain, either from the table or the diagram, that my formula, derived from the "Law of Fatigue," represents his observations fully as well as his own empirical formula.

In Mr. Nipher's former experiments already given, the value of  $a$  comes out to be + 1.094, and in the present experiments it is a negative quantity and equal to - 1.276; whereas, according to direct observation, it ought to be + 1.50. According to the Law of Fatigue, the value of  $a$  should be half the weight of the arm, and a negative value of  $a$  is absurd.

The absurdity, however, is easily explained, and is not in the "Law of Fatigue." The "Law of Fatigue" asserts that the total work done by a group of muscles tired fairly out is inversely proportional to the rate at which they are condemned to act; but it tacitly supposes that the group of muscles in question is not aided by other muscles in any way. This is very difficult to prevent, and it can only be accomplished by a careful study of the muscles used, and by devising a rigorous posture and movement during

\* Continued from p. 466.

the experiments, such as shall compel the group of muscles to do their work and prevent other groups from helping them, which they endeavour to do, from the strong animal instinct of avoiding pain. In the experiments made by myself, Dr. Macalister, and Mr. Gilbert Haughton, the muscles used were two—

1. Supraspinatus
2. Deltoideus Acromialis :

and the palms were supinated, and the plane of motion was the transverse plane.

In Mr. Nipher's experiments (if I understand his description correctly) the plane of motion was 45° in advance of the transverse plane, and the hand was probably pronated. These circumstances would allow the muscles already named to be aided in an irregular manner by the following muscles:—

3. Deltoideus clavicularis
4. Trapezius scapularis (anterior fibres)
5. Pectoralis major (superior fibres).

The assistance supposed given to the group of muscles which are tired out is not sufficient to fatigue the muscular fibres called into

play irregularly, and the Law of Fatigue will not apply to them; and the statement of that law [leading to the cubical hyperbola must be modified as follows:—

Let there be  $m$  fibres tired out,  
 And  $n$  fibres worked but not tired out;  
 And let  $x$  be the mean weight lifted in the hand lifted by the fibres  $n$ ; then the weight really lifted by the fibres  $m$  will be  $(w + a - x)$ . And it is to this quantity only that the Law of Fatigue applies, giving us the formula

$$n(w + a - x)^2 = A. \quad (4)$$

In Mr. Nipher's first set of experiments at fixed rate we found—

$$a - x = + 1'094.$$

And in his experiments now published we have—

$$a - x = - 1'276.$$

From this (supposing the experiments not damaged in their reduction) I should infer that the supraspinatus and acromial deltoid were aided, irregularly, in the two cases by muscular fibres (not tired out), which lifted, respectively 0'41 and 2'77 kilos.

Trinity College, Dublin,  
 March 13

SAMUEL HAUGHTON

P.S.—I have received a letter from Prof. Gustavus Hinrichs, of Iowa State University, in whose laboratory Mr. Nipher was assistant, and who gave Mr. Nipher all possible aid in his experiments. In this letter Prof. Hinrichs states that Mr. Nipher's former experiments were in fact as good as those he last made. I myself believe that, in some respects, they were better.

#### Denudation

MANY students of geology find a difficulty in realising that the effects of denudation are due to the simple action of water set in motion only in ways familiar to us. To them, and indeed to many others, it may be of some interest to observe a working model which, though made without any such design, shows with curious fidelity, on a small scale, the effects which have been produced in the lapse of ages on the great features of our globe.

Londoners will remember that the Serpentine was emptied, and finally refilled, about five years ago. Coping-stones of hewn granite were laid along the margin of the foot-path, and from this, slanting down for about two feet, was a layer of concrete laid about the level of the water line. Possibly this concrete was not of the most durable quality, still it was certainly harder than most of the rocks which bound our coasts. But in the short space of about five years the tiny wavelets of this little lake have worked this smooth sloping hill into a bold and rugged line. In some places, indeed, all the concrete has been washed away, and there is a sandy beach right up to the granite. Two or three years ago the water was at a somewhat lower level than it is now. The traces of the change are recorded, especially on the north side, a little to the east of the boat-houses. There, a double range of "cliffs," one over the other, is to be seen extending for some considerable distance.

This "model" is indeed of so much interest that I ask you to insert this notice of it, for I am sure that many of the readers of NATURE would share the pleasure I have felt in watching the very striking similarity in effects produced by the same agents working on scales so vastly different.

R. H.

#### OUR ASTRONOMICAL COLUMN

THE SUN'S PARALLAX.—In *Astron. Nach.*, No. 2,033, Prof. Galle, Director of the Observatory of Breslau, gives his final deductions with reference to the value of solar parallax from corresponding observations of the minor planet Flora, about the opposition of 1873, which took place while the planet was near perihelion. Observations with this special object in view were made at the Observatories of Bothkamp (Herr von Bulow), Cape of Good Hope, Clinton (N.Y.), Cordoba, Dublin, Leipzig, Lund, Melbourne, Moscow, Parsonstown (the Earl of Rosse), Washington, and Upsala; by 37 N. and 36 S. stars, the sun's parallax is inferred to be  $8''.879 (\pm 0''.0396)$ , which, singularly enough, is the exact figure lately communicated by M. d'Abbadie to the Astronomer Royal, as a first result obtained by M. Puiseux, from observations of the

recent Transit of Venus at the French stations at Peking and St. Paul Island.

TUTTLE'S VARIABLE NEBULA IN DRACO, &c.—This object well deserves regular observation, the evidence in favour of its variability being apparently beyond question. It was first seen by Tuttle in September 1859, and occurs in Argelander's Durchmusterung. On the 24th of September, 1862, D'Arrest, observing with the Copenhagen refractor, describes it as a large bright nebula, 2' long and 80" broad, and he adds: "bene conspicienda tubo quæstore." On the 22nd of August, 1863, after re-examination, he has the note: "I think this nebula was far brighter in the year 1862," and on the 12th of the following month he remarks: "tubo quæstore non amplius discernitur." In a letter to Sir John Herschel, he expresses his conviction that the nebula could not have been so bright as it was in September 1862, in the time of Sir W. Herschel and Messier. Auwers, in Königsberg Observations, xxiv. p. 227, says he found the nebula pretty bright, 2½' long, 1½' broad, the direction of the longer diameter being 50°. If we take the mean of D'Arrest's observations for position (*Siderum Nebulosorum*, &c. p. 333), and bring up to the commencement of 1875, the following place results:—

R.A. ... 18h. 23m. 16s. N.P.D. ... 15° 29' 5"

This nebula is No. 4,415 of Sir John Herschel's general Catalogue. We are able to state that there is some suspicion of variability about No. 4,369 of the same Catalogue (Hind, 1852, April 26), and possibly in the small hazy-looking star preceding the brightest part of the nebula. In April 1852 it was very small and rather faint, perhaps 1' in diameter; it followed Lalande, 33076, 501s, and was 9'4" north of the star. Auwers (Königsberg Observations, xxiv. p. 227) found it pretty faint, 2' diameter, gradually a little brighter towards the middle; a star 12th magnitude situate on the border of the nebula on an angle of about 230° from its centre. Later observations have afforded indication of fluctuating brightness, but are not decisive. Auwers thought he found signs of variability in the nebula No. 4,473 (Hind, 1845, March 30). In a 6-foot Fraunhofer it was pretty bright, round, and from two to three minutes in diameter; and once, 1860, Aug. 16, with the Königsberg heliometer it was "surprisingly faint and of the second class at the highest." Schönfeld has several observations in *Astronomische Beob. zu Mannheim*, 1862; the diameter is variously recorded between 45" and 2", and once it is remarked that the nebula showed strong scintillation and appeared resolvable. D'Arrest, who independently discovered this nebula in the spring of 1852 (*Astron. Nach.*, No. 809) has given his earlier observations in *Resultate aus Beob. der Nebelflecken, Erste Reihe*; in September 1855 he suspected it might prove a cluster of very minute stars. His later observations with the Copenhagen refractor are published in *Siderum Nebulosorum*, &c., where he states that he had not, during sixteen years, noticed any change either of brightness or position; and he mentions further that in April 1866 he detected a number of luminous points. Variability in the case of this object appears hardly to rest upon sufficient proof, considering the effect of indifferent nights upon such observations, but it is suggested in Sir John Herschel's last Catalogue, and on that account is referred to here.

COMET 1766 (II).—If Burckhardt's elliptical elements of the second comet of 1766, discovered at Paris on April 8, are approximately correct, it is not improbable that the comet was observed on its first perihelion passage with that form of orbit. Burckhardt succeeded in representing the rough observations of La Nux at the Isle of Bourbon, extending to May 13, by an ellipse with a period of only five years, Pingré having failed in bringing them into satisfactory agreement with the few observations taken by Messier and Cassini de Thury, at Paris—

from the 8th to the 12th of April, in a parabolic orbit. With the period assigned by Burckhardt, the comet would have passed its aphelion in October or November 1763, at which time the planet Jupiter was near the same heliocentric longitude, and his distance from the comet might have been less than 0.4; indeed, a period very slightly shorter than Burckhardt's, and quite within the probable error of his determination, might have occasioned an extremely close approach of the two bodies, producing, in all probability, a great alteration of elements, and resulting in the ellipse of short period indicated by the observations of 1766. This comet was suspected by Clausen to have been identical with the comet of July 1819, or the comet of Winnecke, which has been observed during the present year; and the very possible close approach to the planet Jupiter in the autumn of 1763 may have been the cause of the introduction of this body amongst the quickly revolving comets of the system. It is also to be remarked that Burckhardt's orbit for 1766 points to a close approximation to the orbit of Mercury; in about heliocentric longitude  $290^\circ$ , the distance is less than 0.025.

### THE SOLAR ECLIPSE

IN continuation of our articles on this subject, we print the following telegrams which have since been received, detailing the results of the observations; together with some remarks which have appeared in the *Times* concerning them.

First, with regard to the Siam party we have, from Singapore, April 15, the following Reuter's telegram with respect to the results obtained:—

"Valuable results were obtained by the English observers of the solar eclipse in Siam. Although the sky was hazy, the results by the prismatic camera were good. The spectroscopic cameras failed. Eight good photographs of the corona were taken."

Next, a *Times* telegram from Dr. Schuster, at Bangkok, as follows:—

"The English observers of the solar eclipse in Siam are remaining a few days at their station to take copies of photographs obtained. Unavoidable accidents prevented them being on the spot until five days before the eclipse. Owing to the untiring energy of Capt. Loftus, the arrangements were nearly complete, and thus partial success of the expedition secured."

Next, a *Daily News* telegram from the special correspondent of that journal with the expedition at Bangkok:—

"The results of the English Eclipse Expedition must be considered merely preliminary, this being the first time spectrum photography has been tried. The prismatic camera shows the rings with protuberances at the edge of the sun, and at least one more ring towards the ultra-violet without protuberances. Eight good photographs of the corona were taken, the exposure varying from two to sixteen seconds."

It will be observed that in none of these telegrams was Dr. Janssen mentioned. It is possible, therefore, that he left Singapore before the arrival of the English Expedition. Be this as it may, he observed the eclipse in Siam, and on Monday last, at the Paris Academy of Sciences, a telegram was read from him to the effect that though the sky was not clear, he obtained results, and that these were confirmatory of those obtained in 1871, so far as they related to the coronal atmosphere.

The news received from the Camorta party is a sad contrast to the above. The following Reuter's telegram, dated "Calcutta, April 18," will no doubt cause universal regret:—

"The Indian astronomical party at Camorta were successful in observing the external contacts during the solar eclipse. They failed, however, to obtain photo-

graphic results, owing to the sky being completely overcast during totality."

The *Times*' comments on the results obtained at Siam are as follows:—

"Reading the above telegram from Dr. Schuster in connection with that which we published in our second edition on Wednesday last (*NATURE*, April 15, p. 474), we see that two-thirds of the work which the Siam expedition went out to do have been successfully accomplished. Photographs giving us the actual shape and many of the conditions of the coronal atmosphere at the present epoch of minimum sun-spots have been secured, and these photographs we shall be able to compare with those taken in India and Java in 1871 at the time of maximum sun-spots. It is not too much to hope that this comparison may teach us much as to the changes in the solar atmosphere which accompany or are brought about by the changes in the spots—changes which require eleven years or thereabout to run through their cycle. But this, after all, is a trifle compared with another part of the work. Not only was photography *pure et simple* employed to tell us the shape and other conditions of the solar atmosphere, but photography *plus* spectroscopy has been utilised to tell us the chemical constitution of the various readings of the sun's surroundings; and it is in this branch of the work that the most valuable of the announced results have been obtained. The Committee of the Royal Society laid so much stress upon this part of the attack that no less than three instruments were devoted to it by the Siam party alone, the work of each being so arranged that it would supplement that accomplished by any of the others.

"A few simple considerations will serve to indicate not only the nature of this part of the work, but how carefully it had been prepared throughout by those upon whom the responsibility of organising the expeditions fell. The brilliancy of the corona has varied enormously—one, indeed, might almost say impossibly—in various eclipses. The celebrated Otto Struve, for instance, has placed on record the fact that in one of the eclipses which he observed its brilliancy was almost insupportable to the naked eye; other astronomers have made use of expressions equally strong, while it is known that, if those who are fortunate enough to have the opportunity of observing eclipses take the precaution of guarding the eye from the direct light of the sun before its disappearance, there is not only light enough from the corona to read by with comfort, but a light surpassing in brilliancy the brightest moonlight we are familiar with in these latitudes. This is so far as the eye is concerned. When we deal with the photographic plate instead of the retina, the brilliancy of the corona becomes yet more certain. A camera of, say, four inches aperture will impress an image of the corona on a prepared plate in far less time than it will impress an image of the moon at its brightest. This is one indication of the photographic brilliancy of the coronal light, and in a former article we took occasion to refer to others of an equally striking kind which were rendered very obvious during the eclipse of 1871. The evidence as to the brightness of the spectrum of the lower layers of the sun's atmosphere is equally strong."

"The Royal Society Committee, therefore, would have been justified in reckoning upon a bright corona. They did so, but at the same time they provided for a very feeble one. Long before the expedition sailed, the members of both parties made some very interesting researches on the possibility of securing photographs of gaseous spectra—that is, precisely such spectra as those which it is natural to expect will be furnished to us by the corona. They found that, with a time of exposure only slightly in excess of that allowed by the eclipse itself, they were enabled to photograph the spectra of chlorine, nitrogen, and other similar bodies—under somewhat complicated instrumental conditions, and when those spectra



were dimmer than the spectrum of the corona is known to be."

The extreme importance which attaches to the determination of the particular class of spectrum under which that of the corona may be classed was pointed out in *NATURE*, vol. xi. p. 201, and on this point the *Times* article says:—

"The most perfect determination would have been accomplished when the peculiarities of the spectrum, of whatever class it might be, with its bright lines or its 'channelled spaces,' had been recorded over a long range. For this purpose the Siam party was provided with a siderostat, a short focus reflector, and a spectroscopic camera of long focus—that is, a spectroscope in which the ordinary observing telescope had been replaced by a lens of long focus and a photographic camera. If everything had been in order, the air perfectly clear, and the corona very bright, this instrument would have given us the most valuable record of all, as we should have obtained a detailed spectrum of the coronal atmosphere and chromosphere from the Fraunhofer line G to far beyond H, the ordinary limit of visibility. This was the most crucial experiment; while it was the one least likely to be realised, its success would have been of the highest importance, as the chemical as well as the physical constitution might have been more or less fully revealed. Next in delicacy to this came a similar arrangement in which the same principles were depended on, but in which, as all the parts were not of quartz and as the focal length of the camera was not so great, equally good results over so large a range were not to be dreamt of. The nature of the spectrum and of some of the constituent gases of the solar atmosphere might have been determined in this way, but the information, though equal in quality to that obtained by the instrument to which we have before referred, would have been deficient in quantity. Still, this information might have been obtained with a less clear air and by less brilliancy in the corona than were necessary for perfect success in the former case.

"In the prismatic camera, an instrument described at some length in our last article (reprinted in *NATURE*, vol. xi. p. 452), we have an instrument which may be held to be certain to give us a valuable result, even if the air be not very clear and if the corona be not very bright. We may say that this was the gross attack upon the chemical nature of the corona, as the siderostat and its accompanying long-focus spectroscope represented the most delicate one. Now this has perfectly succeeded, and in this lies the extreme importance of the observations made in Siam. For some reason which is not yet clear to us, the more delicate ones have failed. On receipt of the first telegram we attributed this failure to the hazy sky, which would as certainly have cut off all the violet rays which alone were to be impressed on the photographic plate as the blue rays are cut off at sunrise, giving us, as the result of the absorption of all the blue light, first the rosy-fingered dawn and then the red sun himself. But from Dr. Schuster's later telegram which we have now received it would appear that some accident had delayed the colonial steamer between Singapore and Siam, and, further, that the observatories which it was hoped would have been built at Chulai Point before the expedition arrived at Singapore had never been built at all; so that the expedition had to proceed direct to Bangkok, and, as an inevitable consequence, spent in royal receptions the time which was absolutely required for the erection and adjustment of the instruments, with or without observatories over them.

"Where and how the delay of four days occurred will, of course, be known hereafter, and it is needless to speculate too closely upon it; but it is clear that Dr. Schuster is inclined to attribute the incompleteness of the results which his party has attained more to this delay than even

to the haze. We can well imagine his disappointment in not having the whole story to tell; but the measure of success his party has achieved is greater than might fairly have been expected from any one expedition, and there is little doubt that the photographs his party has secured will do more to advance solar physics than any permanent records obtained by any former expedition. They are well worth all the time, labour, and thought which have been lavished on the whole attempt.

"Evidence of the highest value bearing on the general nature of the spectrum of the coronal atmosphere in the blue region has been obtained. It was clear that the minimum of success must enable us to compare the coronal atmosphere as a whole with that part of it which is composed mainly of hydrogen, and if there happened to be a remainder, the chemical nature of that remainder would be demonstrated. Let us explain the sense in which we have used the term 'remainder.' Evidence was collected during the eclipse of 1871 which went to show that above the hydrogen region and that occupied by the brighter layers of that unknown substance which lies outside it, there was matter, at the sun, the light of which was powerful in its action upon a photographic plate, while it was comparatively powerless to act upon the eye. The corona depicted on the photographic plate was vastly different from the corona seen by the eye, but from a very different cause—one depending upon the condition of our air, or, at all events, of something between us and the moon.

"Now, if we assume that there is something at the sun enveloping the hydrogen, this something will be cooler, and we have now an abundance of laboratory experiments to show that the molecular constitution of the vapours of the same chemical element at different temperatures is vastly different; and, further, that the spectra of these variously constituted molecules are very definite, and, for the same degree of molecular complexity, have a strange family likeness to each other.

"So far as we have gone already, we have never been able to attack those parts of the sun's surroundings where, in consequence of the reduction of temperature, the various affinities of the molecules have begun to come into play, and combinations of molecules with similar or dissimilar molecules must occur.

"As a consequence of the perfect action of dissociation in the lower layers which has apparently reduced the vapours of all the chemical substances present in the sun's atmosphere to their simplest molecular condition, each vapour in this condition thins out, so to speak, in such a manner that everything represented high up in the atmosphere is more strongly represented low down. But though this is true for a state of things where the molecular constitution is of the simplest, it is quite clear that if we assume an exterior cooler region filled with molecules of greater complexity in consequence of a reduced temperature, if we can get at this region observationally we shall find that the spectrum which it gives will be confined to the higher levels, and will not be represented lower down because the compound molecules which produce it will be broken up by the higher temperature of the subjacent regions.

"Now, it looks as if this important and anticipated result has been established. In a telegram addressed to the *Daily News* it is stated that 'the prismatic camera shows the rings with protuberances at the edge of the sun, and at least one more ring towards the ultra-violet without protuberances.' In other words, the molecules which existed higher up, and built up the stratum the spectrum of which consisted of a ring towards the ultra-violet above the prominence-region, were unrepresented below among the simpler molecules the spectra of which consist of rings extending down to, and actually including, the prominences.

"We have said this much by way of pointing out one

among the many questions on which light may be thrown by the photographs which have been secured in Siam, and which it was hoped would have been duplicated in the Bay of Bengal. As the prismatic camera was the instrument requiring least time for adjustment, so it was the one which could be employed for the longest period during the eclipse. Before and after totality it may have done good service by recording the constitution of the lower part of the sun's atmosphere in a manner which it will not be very difficult to interpret, though certainly the characters will be of the strangest.\*

### ARCTIC GEOLOGY\*

#### III.

#### Coast of Arctic America.—Melville Peninsula.—

Amongst the rock specimens brought home by Dr. Rae, Prof. Tennant recognised gneiss, hornblende slate, and similar metamorphic rocks, a portion probably of the granitic and crystalline rocks described by Sir John Richardson as occupying the central and eastern countries of the Hudson's Bay territory, believed by Sir R. Murchison to belong to the Laurentian system. The latter points out that from the prevalence of a profusion of Upper Silurian corals characteristic of the Niagara and Onondaga limestones (Wenlock or Dudley), the trilobite *Encrinurus punctatus*, and the shell *Pentamerus oblongus*, in the rocks lying on the Laurentian, in the north of the Hudson's Bay territory, and the absence of any traces of Lower Silurian rocks or fossils in the whole of the known polar region, that it is in the highest degree probable that the whole of the country north of the Laurentian Mountains was dry land during the deposition of the Lower Silurian. In the area to the south, and in Europe, and even in the Upper Silurian times, the sea, as evidenced by the presence of *Pentamerus*, was not a deep one, which is borne out by Sir W. Logan's discovery that the Silurian limestones at the head of Lake Temiscamang include enormous blocks of the sandstone on which they rest.†

*Boothia*.—Chalky limestones occur, but do not contain fossils, as at Prince of Wales Island, where the Esquimaux obtain large quantities of native copper on the shore.

Sir James Ross ‡ describes the River Saumarez, lat. 70, long. 92 W., as never frozen, and gives a sketch showing the gorge 80 feet in depth, excavated in hard trap, in which it runs. In the month of July he found several butterflies living near the coast, including an *Hipparchia*, two species of *Colias*, one being near *C. edusa*, and a *Polyommatus*. In Agnew River he found copper ore.

*West Coast of Baffin Sea*.—Crystalline rocks extend from Lancaster Sound to Cape Walter Bathurst and Cumberland Sound, with the exception of Cape Durban, where coal has been found by the whalers, a continuation probably of that of Disco; it also occurs at Kingaiti, two degrees south of Durban, as well as pure graphite.§

*Arctic Archipelago*.—Dr. Houghton, on an examination of the rocks and fossils collected by Sir Leopold M'Clintock from 1849 to 1859, now deposited in the museum of the Royal Dublin Society, was enabled to draw up a geological map of the Arctic Archipelago,|| in which Silurian limestone is shown to occupy nearly all the islands south of Lancaster and Melville Sounds, including the south side of Banks Land, Prince Albert Land, Prince of Wales Land, King William's Island, and Boothia Felix, the central and western area of North Devon, and the whole of Cornwallis Island, &c.; granitoid rocks occurred on either side of Peel Sound, and at Ponds Bay, and

near the mouth of the Fish River; also the eastern coast of North Devon and the opposite side of Baffin Bay, to 77° north latitude.

The lower carboniferous close-grained white sandstone ("Ursa stage" of Heer), with beds of coal, strikes S.W. and N.E. from Baring or Banks Land, where it rests on the Silurian, through Melville Island to Bathurst Island, where it disappears under the carboniferous limestone between Penny Strait and Queen's Channel.

The carboniferous limestone appears to strike nearly east and west; the whole of Prince Patrick Island is composed of it, and the northward portion of Parry Islands and the whole of Grinnell Land;\* scattered over the limestone on several points are patches of lias, in which fossils have been found, notably at Intrepid Inlet, Arnott Bay, Bathurst Island, and on Exmouth Island north of Grinnell Land.

*North Devon*.—From Cape Osborne to Cape Warrender graphic granite occurs, passing into laminated gneiss consisting of black mica and transparent felspar, interstratified with garnetiferous mica-slate, traversed by epidote hornstone overlaid by red sandstone, similar to that of Wolstenholme Sound.

Dr. Sutherland describes the crevasses of the glaciers of Petowak, on the south coast of Jones Sound, as often being filled with mud, which becomes frozen in, and the whole mass breaks off in bergs.

*North Somerset*.—Granite of grey quartz, red felspar, and green chloritic mica occurs on the west coast. Eastward, the island consists of the Upper Silurian sandstones and limestones, the junction of which occurs in Transition Valley. In Bellot Straits granite and syenite rise to a height of 1,600 feet. The base of the Silurian consists of red sandstone and coarse grit, resembling those of Cape Warrender and Wolstenholme Sound, overlaid by ferruginous limestones with quartz grains, earthy limestones, occasionally cream-coloured, dipping from 0° to 5° to the N.N.W.; a few high cliffs occur, but the country is generally low and terraced, the limestone standing out as steps and buttresses, particularly at Port Leopold, where the alternation of hard limestone and soft shales, so well known in European limestone districts, is well shown in Beechey's sketch, at p. 35 of Parry's First Voyage. Amongst the fossils from Port Leopold Dr. Houghton records *Loxonema M'Clintockii*, and specimens of carnelian and selenite.

*Prince of Wales Island*.—Eruptive syenite occurs at Cape M'Clure. The western coast consists of Silurian limestone with fossils, overlaid by bright red ferruginous limestones, and a few beds of bright red sandstones, like the Transition Valley sandstone.

*Banks Land*.—Upper Silurian rocks are succeeded by close-grained sandstone, striking N.E. to E.N.E., of Lower Carboniferous age, and containing thin coal seams, discovered first in Parry Islands by Parry, and afterwards by Austin and Belcher in Melville Island and Bathurst Island. The fossils from this series are similar to those from the Irish Calp series, and from the Eifel. Silicified stems of plants were discovered by M'Clure on the coast of Banks Land, and on those of Wellington Channel by Belcher. The southern entrance to this channel was discovered by Sir Edward Parry in 1819. The lamented Sir John Franklin sailed up it 150 miles in 1845, before being beset with ice at Beechey Island in September 1846.

In Drift on the Coxcomb Range, Banks Land, M'Clure found fine specimens of *Cybrina Islandica*, 500 feet above the sea. In 78° N., Belcher found whale bones on high ground; and marine shells are described by Parry as occurring in clay in the ravines of Byam Martin's Island.

From the coast of Princess Royal Island the Esquimaux procure native copper in large masses. The rocks consist of greyish-yellow sandstone, with *Terebratula aspersa*.

\* The north-west corner of North Devon, not the large tract west of Kennedy Channel.

\* Continued from p. 469.  
† Narrative of Expedition to Shores of Arctic Sea. By John Rae. London, 1859. "Siluria," 3rd edit. London, 1872.  
‡ Narrative of Second Voyage in search of a N.W. Passage, by Sir James Ross, 1855.

§ Quar. Jour. Geol. Soc., vol. ix.

|| "Voyage of the *Ferret*," Appendix IV. (London, 1850.)

*Melville Island.*—Several coal seams occur in the sandstones beneath the carboniferous limestone, striking about E.N.E. The coal burns with a bright flame, with much smoke, and resembles some of the gas coals of Scotland.

In Eglinton Island, between Melville Island and Prince Patrick's, carboniferous limestone with siliceous and ferruginous grits occur, capped by a patch of lias; and highly crystalline gypsum was found N.W. of Melville Island.

*Byam Martin Island.*—Two sandstones occur, one soft streaky, passing into purple sandstone like that of Wolstenholme Sound, the other fine grained, greyish-yellow, with coal seams, like that of Cape Hamilton, Baring Island, containing *Terebratula primipilaris*, Von Buch, and several Eifel forms, and of therefore Upper Silurian or Devonian species. The coal seams occur at a height of 350 feet above the sea, and are described as lignites by Salter.

Exmouth, Table, and Princess Islands, between North Cornwall and North Devon, with Depot Point on the north coast of the latter, form a remarkably fossiliferous area, from which a large number of fossils were collected by Sir Edward Belcher in 1855, and described by the late Mr. Salter.\* Exmouth Island (77° N. lat. and 95° W. long.) rises to a height of 570 feet; the base is soft sandstone abruptly terminating except to the west, overlaid by limestone dipping to the west at 7°, containing *Zaphrentis*, *Spirifer Keilbarvi*, and other species of carboniferous limestone type; at the top a patch of lias occurs, from which the vertebrae and ribs were collected by Belcher, determined by Prof. Owen to belong to an *Ichthyosaurus* near to *I. acutus* of the Whitby Lias.

Lias fossils had previously been discovered by Lieut. Anjou, of the Russian Navy, and described by Wrangel, from New Siberia in Asia, in 74° N. lat., but the presence of lias in these high latitudes remained unnoticed until Belcher's discovery at Exmouth Island, after which several fossils were brought home by Sir Leopold McClintock and Admiral Sherard Osborne, amongst them *Ammonite McClintockii* of Haughton.† A remarkably fossiliferous patch of lias also occurs at Point Wilkie, in Prince Patrick's Island, resting on carboniferous limestones, &c.

*Rhynchonella* of Silurian species were found by the Rev. Longmuir in the ballast of a ship from the coast of Prince Albert's Land; it is worthy of note that one species of *Rhynchonella*, *R. psittacea*, still lives on in these Arctic Seas, and, according to Mr. Gwyn Jeffreys, as far south as Drontheim.

*Cornwallis Islands* consist of Silurian rocks with *Syringopora geniculata*. On its coast and on that of Beechey Island Dr. Sutherland describes marine glacial drift, with Arctic shells, as occurring up to a height of 1,000 feet above the sea, and the presence of blocks of granite and anthracite on the shores of Lancaster Sound, brought by coast-ice.

At Dundas Island, in lat. 76° 15', one of Capt. Penny's crew found a Silurian trilobite, and preserved it, tied in his shirt, when the boat had to be abandoned and a retreat effected. The presence of Silurian rocks at a point so far north, and of sandstones at Wolstenholme Sound, appears to render it probable that the E.N.E. strike of the Carboniferous strata, with their overlying Liassic patches, is cut off eastward, and the Silurian rocks surround them in a basin-like form, an E.N.E. synclinal running through Prince Patrick Island towards Hayes Sound. Detailed examination of the west coast of Smith Sound and Kennedy Channel will have great geological interest, as it will prove whether such a synclinal exists, and if so, whether the Carboniferous rocks are brought in by it, and whether the lower coal-

bearing measures are present on both sides of it, and in what manner they rest on the Silurians of Grinnell Land.

*Grinnell Land.*—From the cliffs of Lady Franklin Bay and from Cape Frazer, in lat. 81° 35' N., long. 70° W., Dr. Hayes found thirteen species of fossils, which were identified by Prof. Meek as Upper Silurian species, belonging to the fauna found in the New York Catskill Shale Limestone of the Lower Helderberg group. Some of the species, as *Zaphrentis Haysii*, Meek, and *Loxonema Kanci*, Meek, are new to science.\* One of the most northern promontories of Grinnell Land is named after the late Sir Roderick Murchison, who, commenting on the collections brought from the Arctic Archipelago by Parry, Franklin, Ross, Back, Austin, Ommaney, and the private expeditions of Lady Franklin, particularly those of Penny and Ingfield, and by the expedition under Sir E. Belcher, endorses the results arrived at by Mr. Salter, that the larger number of fossils obtained belong to Upper Silurian species of rather an American than a European facies, though many species were identical with those of Wenlock, Dudley, and Gotland.† Dr. Conybeare had, in his Report on Geology to the British Association in 1832, already noticed the similarity of the fossils from the Arctic regions to those of the English Upper Silurian series.

Dr. Emil Bessels, the naturalist of the American *Polaris* Expedition under the late Capt. Hall, who had previously taken part in the Prussian Polar Expedition, reports the most northern known land on the east side of the channel, including that portion of Hall's Land examined, to consist of Upper Silurian rocks, with a few fossils.‡

The Esquimaux inhabitants of the coasts of Arctic America, from Behring's Straits to Greenland, speak the same language, and use similar implements. There is no more interesting passage in Prof. Dawkins' recent work § than that in which he compares the identity of type of these implements with those from Dordogne and other parts of France and Belgium, both as regards fowling and fishing spears, darts, and arrows; this likeness extends to the actual shape of the base of insertion into the haft, the haft being formed of mammoth ivory derived from the frozen cliffs, of the very species that was hunted by paleolithic man in the South of France.

These two peoples, separated so widely in time and space, were alike in their artistic feelings and methods of incising, on tusks, antlers, and bones, representations of familiar objects; alike also in their habit of splitting bones for marrow and accumulating them around their dwellings, in their disregard for the sepulchre of their dead, in their preparation of skins for clothing, and in the pattern of the needles used in sewing them together; alike also in their feeding on the musk sheep and the reindeer, and in countless other characteristics. It is well-nigh impossible to resist Prof. Dawkins' conclusion that the Esquimaux is the descendant of paleolithic man, who retreated northwards with the Arctic fauna with which he lived in Europe: though before the close of the glacial epoch it is probable that a continuous land connection existed between France and North America by way of Siberia, remains of the true horse having been discovered associated with *Bison prisus* and the mammoth in Arctic America, and representations of the horse, by a paleolithic artist, occurring on an antler from La Madelaine, and the entire skeleton of a horse from a paleolithic station being preserved in the Lyons Museum.

Sir John Richardson|| speaks of the Kuskutch-chewak people who inhabit the banks of a river flowing

\* *American Journal of Science and Arts*, second series, vol. xl, No. 118, 1855.

† "Open Polar Sea" (London, 1867), p. 440, et seq. "Siluria," 1872, 5th edition, p. 441.

‡ Bull. Soc. Geol. Paris, March 1875. I have to thank Captain Feilden, R.A., naturalist to the Arctic Expedition, for calling my attention to this letter of Dr. Bessels.

§ "Cave Hunting." (London: Macmillan, 1874.)

|| "Arctic Search Expedition." (London, 1854.)

\* "Last of the Arctic Voyages by Sir E. Belcher." (London, 1855)

† Appendix to "Voyage of the *Faen*."

into Kuskokvim Bay, Behring Sea, as believing that the mammoth, whose tusks they constantly find came from the east, and were destroyed by the spells of their *shaman*.

In the kitchen-middens of the deserted Esquimaux villages of Jacobshavn, West Greenland, Dr. Oberg discovered bones of the Walrus and *Cystophora cristata*, which no longer ventures into this ice-blockaded fjord; and also of the bear *Ursus maritimus*, which is now rarely seen south of the Waigat, associated with arrow-heads, stone flakes, and scrapers, of clear quartz crystals and green jasper (*angnak* of the Greenlanders), found in the basalt of Disco,

CHARLES E. DE RANCE

(To be continued.)

#### ON ATTRACTION AND REPULSION RESULTING FROM RADIATION

AT the Royal Society *conversazione* the other evening the most interesting object exhibited was, beyond all doubt, the radiometer of Mr. Crookes. Mr. Crookes' discovery is of so much importance that our readers will be glad to have an abstract of a paper on the subject, recently read by Mr. Crookes at the Royal Society. It was the second part of a paper which the author sent to that Society in August 1873.

Mr. Crookes commences by describing improvements which he has made in the Sprengel pump, and in various accessories which are necessary when working at the highest rarefactions. He describes different new forms which enable the phenomena of repulsion by radiation to be observed and illustrated. A bulb three inches diameter is blown at the end of a glass tube eighteen inches long. In this bulb a fine glass stem with a sphere or disc of pith, &c., at each end is suspended by means of a cocoon fibre. The whole is attached to the Sprengel pump in such a way that it can be perfectly exhausted, and then hermetically sealed. Besides pith, the terminals may be made of cork, ivory, metal, or other substance. During exhaustion several precautions have to be taken, and to get the greatest delicacy in an apparatus of this kind, there is required large surface with a minimum of weight. An apparatus constructed with the proper precautions is so sensitive to heat that a touch with the finger on a part of the globe near one extremity of the pith will drive the index round over 90°, whilst it follows a piece of ice as a needle follows a magnet. With a large bulb very well exhausted and containing a suspended bar of pith, a somewhat striking effect is produced when a lighted candle is placed about two inches from the globe. The pith-bar commences to oscillate to and fro, the swing gradually increasing in amplitude until the dead centre is passed over, when several complete revolutions are made. The torsion of the suspending fibre now offers resistance to the revolutions, and the bar commences to turn in the opposite direction. This movement is kept up with great energy and regularity as long as the candle burns.

Mr. Crookes discusses the action of ice, or a cold substance, on the suspended index. Cold being simply negative heat, it is not at first sight obvious how it can produce the opposite effect to heat. The author, however, explains this by the law of exchanges, and shows that attraction by a cold body is really repulsion by radiation falling on the opposite side. According to the same law, it is not difficult to foresee what will be the action of two bodies, each free to move, if they are brought near to each other in space, and if they differ in temperature either from each other or from the limiting walls of the space. The author gives four typical cases, with experiments, which prove his reasoning to be correct.

Experiments are described with the object of ascer-

taining whether the attraction by heat, which, commencing at the neutral point, increases with the density of the enclosed air, will be continued in the same ratio if the apparatus is filled with air above the atmospheric pressure. This is found to be the case. Various experiments are described with bulb-apparatus, in which the bulb is surrounded with a shell containing various adiabatic liquids, and also with a shell of vacuum. In all cases radiation passed through, producing the normal action of attraction in air and repulsion in a vacuum.

Mr. Crookes next describes a form of apparatus by which measurable results are attainable. It consists of a long glass tube, with a wider piece at the end. In it is suspended a lump of magnesium by a very fine platinum wire, the distance between the point of suspension and the centre of gravity of the magnesium bob being 39<sup>1</sup>/<sub>4</sub> inches. Near the magnesium is a platinum spiral, capable of being ignited by a voltaic battery. Observations of the movement of the pendulum were made with a telescope with micrometer eyepiece. With this apparatus a large series of experiments are described, starting from air of normal density, and working at intermediate pressures up to the best attainable vacuum.

With this apparatus it was found that a candle-flame brought within a few inches of the magnesium weight, or its image focussed on the weight, and alternately obscured and exposed by a piece of card at intervals of one second, will soon set the pendulum in vibration when the vacuum is very good. A ray of sunlight allowed to fall once on the pendulum will immediately set it swinging.

The form of apparatus is next described, which the author has finally adopted, as combining the greatest delicacy with facility of obtaining accurate observations, and therefore of getting quantitative as well as qualitative results. It consists of a glass apparatus in the shape of an inverted T, and containing a horizontal glass beam suspended by a very fine glass thread. At the extremities of the beam are attached the substances to be experimented on, and at the centre of the beam is a small mirror from which a ray of light is reflected on to a graduated scale. The advantage which a glass thread possesses over a cocoon fibre is that the index always comes accurately back to zero. In order to keep the luminous index at zero, except when experiments are being tried, extreme precautions must be taken to keep all extraneous radiation from acting on the torsion-balance. The whole apparatus is closely packed all round with a layer of cotton-wool about six inches thick, and outside this is arranged a double row of Winchester quart bottles filled with water, spaces only being left for the radiation to fall on the balance, and for the index ray of light to get to the mirror.

However much the results may vary when the vacuum is imperfect, with an apparatus of this kind they always agree amongst themselves when the residual gas is reduced to the minimum possible; and it is of no consequence what this residual gas is. Thus, starting with the apparatus full of various vapours and gases, such as air, carbonic acid, water, iodine, hydrogen, ammonia, &c., at the highest rarefaction there is not found any difference in the results which can be traced to the residual gas. A hydrogen vacuum appears the same as a water or an iodine vacuum.

With this apparatus the effect of exposing torsion-balance to a continuous radiation is described, and the results are shown graphically. The effect of a short (11<sup>3</sup>/<sub>3</sub> seconds) exposure to radiation is next described, and the results are given in the form of a Table.

In another Table are given the results of experiments in which a constant source of radiation was allowed to act upon one end of the torsion-beam at a distance of 140 or 280 millims., various substances being interposed. The sensitiveness of this apparatus to heat-rays appears to be greater than that of an ordinary thermo-multiplier. Thus

the obscure heat-rays from copper at 100°, passing through glass, produce a deflection on the scale of 3'25, whilst under the same circumstances no current is detected in the thermo-pile. The following substances are used as a screen, and the deflections produced, when the source of radiation is magnesium-wire, a standard candle, copper at 400° and copper at 100°, are tabulated:—

Rock-salt, 20 millims. thick; rock-crystal, 42 millims. thick; dark smoky talc; plate glass of various thicknesses, both white and green; a glass cell containing 8 millims. of water; a plate of alum 5 millims. thick; calc-spar, 27 millims. thick; ammonio-sulphate of copper, opaque to rays below E, ditto opaque to rays below G.

Mr. Crookes considers that these experiments show that the repulsion is not entirely due to the rays usually called heat, *i.e.* to the extremo- and ultra-red of the spectrum. Experiments have been tried with the electric and the solar spectrum formed with a quartz train, which prove the action to be exerted by the luminous and ultra-violet rays. Some numerical data have been obtained, but unfavourable weather has prevented many observations being made with the solar spectrum.

The barometric position of the neutral point dividing attraction from repulsion is next discussed. The position of this point varies with the density of the substance on which variation falls, the ratio of its mass to its surface, its radiating and conducting power for heat, the physical condition of its surface, the kind of gas filling the apparatus, the intensity of radiation, and the temperature of the surrounding atmosphere. The author is inclined to believe that the true action of radiation is repulsion at any pressure, and that the attraction observed when the rarefaction is below the neutral point is caused by some modifying circumstances connected with the surrounding gas, but not being of the nature of air-currents. The neutral point for a thin surface of pith being low, whilst that for a moderately thick piece of platinum being high, it follows that at a rarefaction intermediate between these two points pith would be repelled, while platinum was attracted by the same beam of radiation. This is proved experimentally; and an apparatus showing simultaneously attraction and repulsion by the same ray of light is described and illustrated in the paper.

Mr. Crookes concludes his paper with a discussion of the various theories which have been adduced in explanation of these phenomena. The air-current and electrical theory are considered to have been abundantly disproved. The following experiment is given to show that Prof. Osborne Reynolds's hypothesis of the movements due to evaporation and condensation at the surface will not account for all the facts of the case, and that, therefore, he has not hit upon the true explanation. A thick and strong bulb was blown at the end of a piece of very difficultly fusible green glass, specially made for steam-boiler gauges. In it was supported a thin bar of aluminium at the end of a long platinum wire. The upper end of the wire was passed through the top of the tube and well sealed in, for electrical purposes. The apparatus was sealed by fusion to the Sprengel pump, and exhaustion was kept going on for two days, until an induction-spark refused to pass across the vacuum. During this time the bulb and its contents were several times raised to a dull red heat. At the end of two days' exhaustion the tube was found to behave in the same manner as, but in a stronger degree than, it would in a less perfectly exhausted apparatus, *viz.*, it was repelled by heat of low intensity and attracted by cold. A similar experiment was next tried, only water was placed in the bulb before exhaustion. The water was then boiled away *in vacuo*, and the exhaustion continued, with frequent heating of the apparatus to dull redness, for about forty-eight hours. At the end of this time the bar of aluminium was found to behave exactly the same as the one in the former experiment, being repelled by radiation.

It is impossible to conceive that in these experiments sufficient condensable gas or vapour was present to produce the effects Prof. Osborne Reynolds ascribes to it. After the repeated heating to redness of the highest attainable exhaustion, it is impossible that sufficient vapour or gas should condense on the movable index to be instantly driven off by the warmth of the finger with recoil enough to drive backwards a heavy piece of metal.

Whilst objecting to the theories already advanced as not accounting for all the facts of the case, Mr. Crookes confesses that he is not as yet prepared with one to put in their place. He wishes to avoid giving any theory on the subject until a sufficient number of facts have been accumulated. The facts will then tell their own tale. The conditions under which they invariably occur will give the laws, and the theory will follow without much difficulty.

#### THE FATAL BALLOON ASCENT

THE readers of NATURE are no doubt aware of the fatal result of the recent ascent of the balloon *Zenith*; the following authentic details at first hand will no doubt be of interest:—

CIRON (Indre), April 17.

The *Zenith* was sent up on the 15th of April in order to determine the quantity of carbonic acid contained in the atmosphere at an altitude of 24,000 feet. The "let go" was given at twenty-five minutes to twelve A.M. The captain was M. Sivel, and there were only two passengers, M. Gaston Tissandier and M. Crocé-Spinelli. The ascent took place gradually in a slight E.N.E. wind, the sky being blue but vaporous. The rate of ascent was calculated to be nine feet per second, but diminished gradually. Shortly after one o'clock the altitude obtained was 22,800, and the passengers were quite well, although feeling weak. The inhalation of oxygen produced good restorative effects when tried. Then a consultation took place, and the *Zenith* being in equilibrium, a quantity of ballast was thrown overboard. M. Tissandier then fainted, and is ignorant of what was felt by his friends.

At eighteen minutes past two he was awakened by M. Crocé-Spinelli warning him to throw over ballast as the balloon was fast descending. He obeyed mechanically, and at the same time Crocé-Spinelli threw overboard the aspirator, weighing eighty pounds. Tissandier then wrote in his book a few disconnected words, and again fell asleep for about an hour. When he awoke, the balloon was descending at a terrific rate; no more ballast was left to be thrown away, and his two friends were suffocated. Their faces had turned black, and the blood was flowing from their mouth and nose. They were evidently dead. It was a terrible situation.

The only resource was to cut the grapple rope a little before the instant when the car should strike the ground, which Tissandier did with astonishing coolness. The wind had increased in strength, and Tissandier was obliged to tear open the balloon in order to stop it. It was caught on a hedge in a commune of Indre, called Ciron, 190 miles S.S.W. from Paris.

The tragic fate of Sivel and Spinelli is to be ascribed to the fatal resolution of accomplishing, at any price, a height of 24,000 feet, but mainly, no doubt, to the throwing out of the aspirator, which will be discovered somewhere perhaps unbroken, as it had been provided with a parachute.\*

The only instruments broken are the potash tubes for the absorption of carbonic acid. The experiment had been tried successfully; two aspirators had been used, but the tubes were not lodged in their proper case.

Careful readings were taken with the thermometer, and,

\* According to the *Times* correspondent, this and other things have been found.

although diminishing, the temperature was remarkably high :—

9,600 feet	...	...	...	1° Centigrade
12,000 "	...	...	...	0° "
13,200 "	...	...	...	0° "
15,420 "	...	...	...	-5° "
19,600 "	...	...	...	-8° "
22,960 "	...	...	...	-10° "

The temperature of the gas in the interior of the balloon was also observed by a new system. It was found to vary very little, owing to the heating power of the sun, and at 22,900 feet was found to be + 25°, showing a difference of - 35° centigrade with the temperature of the air.

This result is extremely remarkable, and was observed at several intervals, although the gas ought to suffer a diminution of temperature owing to its constant dilatation.

Although the air was clear and the sky quite blue, a number of cirrus clouds were seen on the horizon, which could not be seen from the surface of the earth.

As far as can be inferred from the ascertained facts, there was no sensible variation in the direction of the air for an immense altitude. It accounts for the unprecedented beauty of the weather and the purity of the air; it may be taken as a fair prognostic of the continuance of good weather for at least a few days.

The aeronauts had in their cars maximum barometers in a sealed box, in order to test the altitude in which they were travelling. These tubes, having been saved, will be tested in the laboratory of M. Hervé-Mangon.

M. Tissandier was slightly hurt in his fall. Great sympathy has been elicited for Sivel and Crocé-Spinelli, who may be said to have spent their lives in the battle-field of the air. Sivel was formerly a captain of the mercantile navy; his age was forty-two years. Crocé-Spinelli was a pupil of the École Centrale, and was thirty-two years of age. The former was a widower, and leaves a girl, and the second was a bachelor. A subscription is being contemplated for the fatherless child.\*

The *Zenith* is in good order, and will be put in repair. Although marred by a sad tragedy, and although the composition of the air has not been ascertained, as was contemplated, the expedition cannot be said to be devoid of results. It will serve as an incitement to further investigation in the same direction, but with greater caution.

W. DE FONVILLE

Since the date of our correspondent's letter, it would seem from the indications shown by the uninjured barometers that the height reached was actually 14,000 metres, or eight miles. On Tuesday the bodies of Sivel and Spinelli were interred with well-deserved honours in Père la Chaise, many eminent scientific men being present. Subscriptions on behalf of those who were dependent on the two martyrs to science will, we believe, be received at the office of the *Courrier de l'Europe*, Tavistock Street, Covent Garden.

### NOTES

THE Royal Society during the present session have elected the following nine eminent scientific men as foreign members:—Pierre J. van Beneden, of Louvain; Joseph Louis François Bertrand, of Paris; Alfred Louis Olivier Des Cloizeaux, of Paris; Hippolyte Louis Fizeau, of Paris; Elias Magnus Fries, of Upsal; Jules Janssen, of Paris; Auguste Kekulé, of Bonn; Gustav Robert Kirchhoff, of Berlin; and C. Ludwig, of Leipsic.

\* The *Times* correspondent states that M. Sivel leaves a widow as well as a child, and that M. Spinelli was the sole support of his parents. To quote the words of the correspondent, "The scientific world will doubtless respond liberally to this appeal, for MM. Spinelli and Sivel lost their lives, not in gratifying foolhardy curiosity, but in endeavouring to penetrate the secrets of the atmosphere for the benefit of science." M. Tissandier's own account of the journey will be found in Monday's *Times*.

Also the Earl of Carnarvon, Mr. W. E. Forster, and Sir Stafford Northcote have been elected Fellows of the Society.

THE names of the fifteen candidates for the Fellowship selected by the Council of the Royal Society to be recommended for election at the meeting on June 3 are W. Archer, J. R. Bennett, D. Brandis, J. Caird, J. Casey, A. Dupré, J. Geikie, J. W. L. Glaisher, J. B. N. Hennessey, E. Klein, E. Ray Lankester, Capt. Nares, R. S. Newall, W. C. Roberts, and Major-General Scott.

THE annual meeting of French astronomers took place recently at the Ministry of Public Instruction, under the presidency of M. Leverrier. It was composed of M. Dumesnil, the director of the Enseignement Supérieur, the members of the Council of the Paris Observatory, and the directors of the Marseilles and of Toulouse Observatories. The Observatory at Algiers not having been yet reorganised was not represented, though measures are very shortly to be taken to get this done. An Observatory is to be created at Bordeaux, and another at Toulouse. It is stated, moreover, that a Physical Observatory is to be created in Paris or the vicinity, and placed under the direction of the Bureau des Longitudes. The Council of the Observatory is said to have unanimously passed a vote recommending that no one should be a member of two observatories at the same time.

GENERAL SIR EDWARD SABINE has been elected a corresponding member of the French Academy of Sciences.

THE German Anthropological Society will hold its general meeting at Munich in August next, and it is intended to arrange an exhibition of the most interesting objects of Celto-Germanic origin, found upon Bavarian ground. Bavaria possesses great treasures of this kind in its Government and private collections, and these objects are of the highest importance as regards the history and culture of the earliest periods. Men of scientific authority will superintend the exhibition, which, it is proposed, is to consist of the following seven groups:—1. Flint implements found in Bavaria, such as hammers, knives, arrows, &c. 2. Bronze weapons and ornaments of the same material, particularly swords, daggers, lances, arrow-points, sickles, and objects used for personal adornment. 3. Iron weapons, such as swords, hatchets, daggers, and knives. 4. Ornaments of amber, glass, or earthenware (beads). 5. Glass and earthenware vases. 6. Casting-moulds for Celto-Germanic weapons. 7. Coins, principally Celtic ones, the so-called "rainbow-dishes." All the objects will be well taken care of, and a guarantee is given for safe keeping and return. All expenses for carriage will be defrayed by the Society.

DR. SCHWEINFURTH has just received news from the Upper Nile, stating that Mohamed Abd-es-Samat, the Nubian ivory dealer who had rendered the German traveller most important help in pursuing his explorations in the Niam-Niam and Mombuku districts, was killed in December last by Niam-Niam soldiers, who had besieged and finally taken his Seriba (a sort of block-house). The assistance rendered to Dr. Schweinfurth by this ivory dealer was of the highest importance, and was acknowledged both by the German and Egyptian Governments. The history of the investigation of Inner Africa, which impartially notes down the names of all men of merit, independent of their nationality, faith, or colour, will also preserve that of Abd-es-Samat, by the side of his illustrious German friend.

THE *Kölnische Zeitung* of April 17 contains an elaborate and highly interesting account of the festival which took place at Naples a few days ago, upon the occasion of the opening of the Zoological Station. Dr. Anton Dohrn, the founder of the station, made the opening speech. After him Prof. Panceri, of Naples University, thanked Dr. Dohrn in the name of Italy for his great efforts in carrying the important work to a successful

result. The Prefect of Naples had sent a deputy, and many eminent scientific men were present. After the festival, the guests visited the magnificent aquarium and the working room of the zoologists; there are eighteen gentlemen now working there. The States which have reserved working tables at the Station are Prussia, Italy, Russia, Austria, Bavaria, Baden, Holland, Saxony, Alsace and Lorraine, and Mecklenburg; also, as our readers know, a table has been reserved for the University of Cambridge.

THE writer of the article on the *Times* Weather Chart in last week's NATURE (p. 473), requests us to state that the word "barograms" in the fourth paragraph should have been "isobars."

MR. EDWARD BELLAMY, F.R.C.S., will commence his course of lectures on "The Anatomy of the Human Form" in the theatre of the South Kensington Museum on Friday, 23rd inst., at 4 P.M.

M. WURTZ has tendered his resignation as professor in the Paris Medical School, and it appears to have been accepted; but before taking any definite step, M. Wallon has summoned a meeting of the professors to ascertain who they thought ought to be appointed Dean of the Faculty of Medicine.

ON April 16 a meeting of botanists from various parts of Scotland was held at Perth to hear the report of the committee (appointed at the Fungus Show held in Aberdeen last autumn) to organise a Scottish Cryptogamic Society. A constitution was adopted, and office-bearers were elected for the present year, the President being Sir T. Moncreiffe of Moncreiffe, Bart.; Vice-president, Prof. Dickie, Aberdeen; Secretary, Dr. Buchanan White, F.L.S. It is intended to have a show of cryptogamic plants, especially of fungi, every year in various districts of Scotland in rotation, and the show for this year is to be in Perth in the last week of September, when it is expected that a very large number of specimens will be exhibited. The Society will also adopt other means of promoting the study of Cryptogamic Botany, and it is possible that it will from time to time issue a few fasciculi of "New or rare Scottish Cryptogamic Plants." English cryptogamologists desirous of becoming corresponding members of the Society should communicate with the Secretary (Dr. Buchanan White, Perth), from whom information regarding the Society or the show may be obtained.

M. LEVERRIER being deeply engaged in his official work at the Observatory, has no time to deliver his regular course of lectures on astronomy at the Sorbonne. M. Wolf has been appointed by him as his substitute.

LARGE meteors were seen during the recent clear nights in different places in France; at Havre on the 12th, and at Paris on the 10th. The Paris meteor was seen at two o'clock in the morning; the direction was not specified, but the colour was green. The Boulevard St. Michel appeared as if it were illuminated. The Havre meteor was very large, going with an immense velocity from south-east to north-west.

THE first storm of the season in Central France was felt on April 7 in the department of Gers, near the small picturesque town of Lectoure. The spire of Saint Martin de Gorgue was almost demolished by a thunderbolt. Very few French churches, especially in small country places, are supplied with lightning conductors.

THE halo which was observed by M. de Fonvielle at Paris on the 12th of March, and also in England, was observed at the same time at Montsouris Observatory, about six miles south of Montmartre, and termed "a trace of halo," instead of a perfect one. As the moon had the same altitude for both observers, the icy cloud must have been suspended at a small distance, and nearer the zenith at Montsouris than at Montmartre. If

telegraphic signals were exchanged during their appearance, these phenomena could be discussed with great benefit to science. Auroræ Boreales were frequent during the beginning of March, which is in accordance with the opinion of meteorologists that they are caused by icy particles rendering the upper part of the atmosphere more conductive of electricity.

SIX useful lectures by Prof. Frankland on "How to teach Chemistry," originally delivered to science teachers, will shortly be published by Messrs. Churchill, from notes taken and edited, with Dr. Frankland's sanction, by Mr. George Chaloner, F.C.S.

WE hear that New College and Balliol College, Oxford, and the municipal authorities at Bristol, have finally determined to establish a new College of Science and Literature at Clifton. (See NATURE, vol. x. p. 93.) It is anticipated that 50,000*l.* will be raised for the buildings in Bristol. The two above-named Colleges have each promised 5,000*l.* towards the foundation, and it is said that they both intend giving a further sum towards the endowment.

THE Committee appointed to examine into the advisability of a new survey of Massachusetts (see NATURE, vol. xi. p. 381) have reported strongly in its favour, almost to the full extent desired by the scientific men whose advice they asked. To a small pamphlet on the subject which has just come to hand, is appended what we take to be the draft of an Act which the Committee advise the Senate and House of Representatives to pass. The Act recommends the appointment of a Board of seven persons, with the Governor and a Secretary. This Board will employ suitable persons to make a thorough topographical, geological, and biological survey of the State. The Board is to see to the preparation of a topographical map on the scale of 1 : 25,000, and also will prepare from the surveys enlarged maps on the scale of 1 : 10,000. Careful reports are to be prepared upon the geology of the State, with special reference to the discovery of coal, ores, and building material of economic value; also reports on the zoology and botany of the State, comprising catalogues of the animals and plants, with particular reference to those injurious and those beneficial to man. The proposed Act also provides that 30,000 dollars be annually appropriated for the expenses of the survey, and that yearly reports be presented to the Legislature. These provisions are on the whole satisfactory, and there is no doubt the Massachusetts Legislature will give them the force of law.

FROM the Seventeenth Report of the East Kent Natural History Society, we are glad to see that it continues prosperous, "losing nothing of its interest and usefulness." The total number of members is ninety-four. The Report contains a brief account of the Society's meetings during 1874, from which it would seem that the actual work of the Society is carried on by a very small proportion of the members.

THE additions to the Zoological Society's Gardens during the past week include an Australian Dingo (*Canis dingo*) from Australia, presented by the Zool. and Accl. Soc. of Victoria; a Crested Porcupine (*Hystrix cristata*) from W. Africa, presented by Mr. G. W. Venderkist; two Red-footed Crab-eating Raccoons (*Procyon cancrivorus*) from Demerara, presented by Mr. J. R. II. Wilton; an Impeyan Pheasant (*Lophophorus impeyanus*) from the Himalayas, presented by Capt. J. E. Whiting; a Rufous Tinamou (*Rhynchotus rufescens*) from Brazil, presented by the Viscount Hill; a Sharp-nosed Crocodile (*Crocodilus americanus*) from Jamaica, presented by Capt. A. M. Drummond; ten Green Lizards (*Lacerta viridis*) from Jersey, presented by Mr. G. E. Drage; a Quica Opossum (*Didelphys quica*) from Brazil, a Red Ground Dove (*Geotrygon montana*) from South America, purchased.



## ACCIDENTAL EXPLOSIONS \*

## III.

A FEW substances well known to chemists are so very unstable in character, or are so very difficult to prepare in a condition approaching purity, that they either begin to undergo change as soon as they have been produced, or very shortly afterwards, such change proceeding sometimes gradually and quietly until the substance has been transformed into non-explosive bodies, or occurring, in other instances, with a rapidity speedily resulting in the violent decomposition or explosion of the substance. Injuries more or less severe have been inflicted upon the discoverers or investigators of substances of this kind, or upon those who prepare them and exhibit their properties for instructional purposes, and such accidents occasionally occur even though all possible or reasonable precautions appear to have been taken to guard against them. It has occasionally also happened that serious accidents have resulted from attempts to apply to practical purposes the explosive power of such substances (as, for example, the chloride of nitrogen and iodide of nitrogen) by persons imperfectly acquainted with their properties or those of explosive substances generally. The great danger in which want of knowledge may involve experimenters in this direction is too obvious to need being dwelt upon.

The risk of accident resulting from the liability of explosive compounds to so-called spontaneous decomposition has been on several occasions exemplified in the past history of the two most important of these compounds, gun-cotton and nitro-glycerine. The stability of properly purified gun-cotton, as well as that of nitro-glycerine, have, however, now been for some time past fully established, and no difficulty exists in carrying on with safety their manufacture on such a scale as to satisfy the continually increasing demand for efficient preparations of these violent explosive agents. At the same time the experience of the last few years has afforded repeated illustrations of the terrible risks and responsibilities incurred by manufacturers of these substances by the slightest departure from conditions essential to perfection and safety of manufacture, or by a relaxation of the strictest supervision in the production, purification, and storage of the materials.

In these respects the utilisation of explosive compounds of this class involves special risks not attendant upon the manufacture of gunpowder and modifications of that substance; in others, however, it presents important elements of comparative safety. For example, the manufacture and purification of gun-cotton, and its conversion into the compressed or granulated substance, are absolutely safe operations, the material being wet throughout the entire course, and therefore quite uninflamable, until, when completed, it is dried by long exposure to air, or by artificial heat. On the other hand, gunpowder, and all preparations of similar nature, are explosive from the very commencement of their manufacture.

Accidents at gunpowder factories are very frequent, and though they may not often involve considerable loss of life or destruction of property, the fact that their occurrence must in most instances be caused by partial, occasional, or complete and persistent neglect of precautions absolutely essential to the safety of the people employed in the works, or to a reduction of the risks of accident to the minimum, points to the necessity for improved legislation connected with manufactories of gunpowder and other explosive preparations, whereby the proper attention to regulations and precautions for safety may be rendered compulsory, and seconded by an efficient system of inspection.

After stating a number of precautions that ought to be adopted in all gunpowder manufactories, Prof. Abel said that lastly, though properly first in importance, the manufacturers of gunpowder and other explosive agents should not only themselves possess some scientific as well as a practical knowledge of the nature and properties of the substances in the manufacture of which the lives of their workmen are at stake, but they also should ascertain and insist that at any rate the persons who act as managers and foremen in their factories should not be deficient in the elementary knowledge indispensable to a proper performance of their duties.

Major Majendie, the Government Inspector of Gunpowder Works, &c., has reported officially that he was "much struck, in the course of his inspections, with the extraordinary ignorance of even the most elementary dangers, and the precautions neces-

sary for avoiding them, which prevails among persons in charge of important factories and magazines," and that there can be no doubt that to the ignorance and incompetence of such persons a large number of the accidents which occur are indirectly due. Surely it is in the interest of employers to adopt measures for securing that the management of their works is in the hands of competent men, experienced in the details of the manufacture, and possessing adequate general education and technical knowledge to fit them for posts of such responsibility. The obvious mode of securing this is to render it compulsory for such men to obtain certificates of competency before they can hold responsible appointments in manufactories of gunpowder and other explosive agents.

The manufacture of fireworks, ammunition, percussion caps, and other articles involving the application of explosive agents is, it need scarcely be stated, attended by liability to accidents similar to and sometimes even greater than that existing in manufactories of gunpowder and materials of similar nature, and necessitates the adoption of precautions of the same nature as apply to these works.

Such necessity has, however, been very much disregarded in the arrangement and management of factories of this kind, and many very sad casualties have resulted either from utterly inadequate arrangements for localising explosions and reducing them to small proportions, by regulating the quantities of material dealt with in one building, and sufficiently separating and subdividing the manufacturing operations, or from neglect of simple regulations for excluding sources of fire from the buildings.

There are several important instances of accidental explosions on record which have occurred in the manufacture of pyrotechnic compositions and other articles of explosive nature, in consequence of a liability to the establishment of chemical activity between the ingredients of such preparations by even very slight inciting causes. Thus, certain descriptions of coloured fires are readily susceptible of so-called spontaneous ignition or explosion, either simply from the unstable nature of one or other of their ingredients, or from so apparently trifling a cause as the absorption of a small amount of moisture, or the employment of a small quantity of an easily oxidisable oil or fat in connection with their application to pyrotechnic purposes. In one instance, some signal lights, composed of a mixture of ingredients which long experience had shown to be in every way as permanent as those of gunpowder, were found to be undergoing decomposition to an extent which, had it not been noticed in time, must have resulted in serious consequences. The cause of this change baffled inquiry for some time, but ultimately it was clearly established that a very minute quantity of free acid contained in the paper linings of the cases in which the composition was confined (and derived from the antichlore used in the manufacture of the paper) had set up an action between the saltpetre and the orpiment composing this material, which spread gradually but with increasing rapidity through the highly compressed mass, being of course accelerated by the heat developed.

After referring to the great dangers arising from the manufacture of fireworks in dwelling-houses of the lower classes in crowded districts, the lecturer said that the fearful recklessness with which gunpowder and other explosive agents are handled and used by uneducated persons, such as these small firework makers, of which there are large numbers in the mining and manufacturing districts, and by the most extensive consumers of powder, namely, the miners and quarrymen, can scarcely be realised by anyone who has not had opportunity to acquire by personal observation a knowledge of the state of things.

Prof. Abel then gave instances of the incredible carelessness frequently shown by miners in their preparations for blasting both with gunpowder, gun-cotton, dynamite, and other explosive substances.

It is, however, more particularly from the fact that there are no regulations forbidding or restricting the making up, in dwelling-houses, of blasting cartridges, mining fuses, and the so-called powder straws used in blasting, that the chief liability to accidental explosions in mining districts arises. Miners are constantly in the habit of keeping considerable quantities of powder in their dwelling-rooms, and making up their cartridges or fuses (straws) at night.

After giving some illustrations of the disastrous results of carelessness in the handling of gunpowder, Prof. Abel said that it naturally follows that other explosive agents, such as dynamite and gun-cotton, should be treated with similar and perhaps even greater recklessness. The apparently less dangerous nature of

\* Abstract of a lecture delivered at the Royal Institution, March 22, by Prof. F. A. Abel, F.R.S. Continued from p. 478.

such materials when unconfined tends to render the miner even more regardless of precautions, and hence it is unquestionably wrong to foster the notion of the safety of these materials in the hands of the miner, especially as it frequently occurs that the men who use these materials are unable to read the printed instructions which are supplied by the manufacturers with the cartridges for the purpose of guarding against accident.

It does not admit of dispute that the recklessness of the miner has actually been fostered hitherto by the utter disregard of all ordinary precautions which they must but too frequently witness at the stores where the powder is sold or issued to them. The practices of small dealers in gunpowder present illustrations of ignorance and recklessness, if anything, even more appalling than those which the habits of the miners furnish. The manner in which powder is often dealt with by those in charge of the stores or magazines in quarries or mines, and who have to issue supplies to the men, is illustrated by one or two examples from a report to the Home Office by Major Majendie. As an extreme instance of recklessness the case of a man is quoted who was in the habit of boring into the barrels with a red-hot poker; on one occasion, the lid of the barrel being thinner than usual, the heated iron was thrust into the contents of the barrel, and the man fell a victim to his very original mode of dealing with packages of gunpowder.

In some mining districts it has been customary to pay no regard whatever to the suitability, in point of safety, of the localities selected for the storage of powder. It has not unfrequently been kept in large quantities (e.g. 500 lb.) in ordinary buildings, quite close to dwelling-houses. Even where magazines have been provided, in connection with extensive mines and quarries, many instances are on record of gross ignorance or carelessness in regard to the precautions essential to the safe handling of gunpowder.

The strenuous exertions of the Government inspectors during the last few years have already resulted in a considerable amelioration of this lamentable condition of things, although the existing state of the law affords them little power to enforce simple regulations which are vital to the safety of the people employed, and often of the neighbourhood, but scant regard being but too frequently paid to the position of even extensive stores or magazines with reference to contiguous habitations.

The utter inadequacy of the existing regulations as to the transport of powder, &c., by land or water, and the flagrant manner in which even these defective regulations are but too frequently disregarded, are matters to which public attention has been much directed since the explosion in October last, and which are but in harmony with the negligence and ignorance displayed to so alarming an extent in connection with the handling and storage of gunpowder. Thus, the packages (barrels, &c.) in which powder is transmitted to distant places are often so imperfectly constructed that the grains escape into the cart, or the hold of a vessel, where they may become mixed up with grit and be eventually trampled upon. As regards the vehicles in which the powder is transported, some regulations exist with respect to the employment of covered or uncovered carts with reference to quantities of powder exceeding considerable limits, but there is no law requiring carts or barges to be specially constructed or employed so as to exclude sources of danger. In the mining districts and even in towns powder is constantly conveyed in dangerous quantities in ordinary carts, which may have been used for carrying stones, coal, or road rubbish, and is often packed with other goods, such even as lucifer matches and petroleum; there is no regulation to prevent the person in charge from smoking while in his cart, or stopping at a public-house, leaving the powder standing at the door. Prof. Abel quoted instances of the reckless carriage of powder in public conveyances, and of the transport of very large quantities (many tons) of powder through crowded thoroughfares in large towns (Edinburgh and London) with little or no precautions. The disregard of necessary precautions in the transport of merchants' powder by water was dwelt upon and contrasted with the precautions adopted by Government as absolutely necessary, and some severe comments were made upon the practice, which had been common, of stowing gunpowder in barges as part of miscellaneous cargoes which include even such materials as petroleum spirit.

After referring in detail to the precautions insisted on in the transport and storage of Government gunpowder, and to the effect of recent legislation with regard to explosive substances, Prof. Abel concluded by stating that the beneficial results attainable by a systematic and thoroughly authoritative supervision,

by Government inspectors, of factories and stores of explosive agents, if conducted with intelligence and discretion, have been most convincingly demonstrated by the great good which it is admitted on all sides that the inspectors have already succeeded in accomplishing, even with the very insufficient powers which the present state of law affords them. The favourite argument of some, that Government inspection must operate mischievously, by diminishing private responsibility, has certainly received no support from the results of inspection, so far as the experiment has been tried. It will scarcely be asserted that a manufacturer or store-holder who may have willingly adopted, as suggestions which the inspector has no power to enforce, measures conducive to the safety of life and property, would be careless in the application of those measures because their adoption was no longer optional, or because the responsibility for their due observance was to some extent shared by the inspector. This very system of inspection cannot fail to benefit those interested in different branches of the industry of explosives by reducing the necessity for hard and fast rules with respect to the arrangement and conduct of works, which might in many instances entail hardship or inconvenience without any real necessity, and by strengthening the hands of factory-owners, and thus rendering comparatively easy the proper observance and enforcement of regulations for the safety of the men and the works. It is, however, especially in connection with the storage, transport, and employment of gunpowder and other explosives in mining districts that efficient inspection, supported by the reasonable power which a well-considered Act of Parliament cannot fail to afford, may be confidently expected to produce important beneficial results, not the least of which will probably be the wholesome influence exercised indirectly, by the force of example, upon the miner or pitman, whose ignorance has fostered the indifference with which long habit has led him to regard the possibility of danger.

But although improved legislation, and the beneficial regulations thus supplied, may be confidently hoped to effect an important reduction in the number and magnitude of the disasters now recorded as accidental explosions, it would obviously be worse than shortsighted to encourage a reliance upon legislation alone as a safeguard against the evils which lead to casualties of this kind. Punishments inflicted for transgression of the law may engender caution, but the disasters which arise from ignorance are not likely to be importantly reduced in number by legislative enactments alone.

It is to the general promotion of education among the people, and to the spread of scientific and technical knowledge, if even of the most elementary kind, among employers and employed, that we must look for a substantial diminution of these casualties, which the uneducated mind is but too prone to attribute to accident, and the prevention of which rests, at any rate to a large extent, with those who are at present tacitly content to regard them as inevitable.

## SOCIETIES AND ACADEMIES

### LONDON

Royal Society, April 8.—"On the Development of the Teeth of Fishes" (Elasmobranchii and Teleostei), by Charles S. Tomes, M.A.; communicated by John Tomes, F.R.S.

Observations upon many mammals, reptiles, and fishes. Led the author to the following general conclusions as to the development of teeth:—

(i.) All tooth-germs whatever consist, in the first instance, of two parts, and two alone—the dentine papilla and the enamel-organ.

(ii.) The existence of an enamel-organ is wholly independent of the presence or absence of enamel upon the teeth; examples of this have been recorded by Professor Tomes and by the author among mammalia, and are common amongst reptiles and fishes.

(iii.) Nothing justifies the arbitrary division into "Papillary," "Follicular," and "Eruptive" stages; nor does any open primitive dental groove or fissure exist in any creature examined.

(iv.) In all cases an active ingrowth of a process from the oral epithelium, dipping inwards into solid tissue, is the first thing distinguishable, although the formation of a dentine papilla opposite to its deepest extremity, goes on *pari passu* with it from the development into an enamel-organ.

(v.) A special capsule or follicle to the tooth-germ may or may not be present; when present it is in part a secondary develop-

ment from the base of the dentine papilla, in a part a mere condensation of surrounding tissue.

"Experiments to ascertain the Cause of Stratification in Electrical Discharges *in vacuo*," by Warren De la Rue, Hugo W. Müller, and William Spottiswoode.

"First Report of the Naturalist attached to the Transit of Venus Expedition to Kerguelen's Island, December 1874," by the Rev. A. E. Eaton; communicated by the President.

[These are two long and important papers, which we hope to be able to be able to give next week.]

Linnean Society, April 15.—Dr. G. J. Allman, president, in the chair.—Prof. A. Dickson, M.D., Mr. J. F. Duthie, and Mr. H. C. Sorby, F.R.S., were elected fellows. The following papers were read:—On the nature and productions of the atolls of the South Pacific, by the Rev. Thos. Powell.—Papers on the botany of the *Challenger* Expedition; xxv., On the Diatomaceæ collected by Mr. H. N. Moseley in Kerguelen's Land, by the Rev. E. O'Meara; xxvi., Letter from Mr. H. N. Moseley on an edible Chinese *Sphæria*, known as "winter worm-grass," parasitic on certain larvae (this was stated by Mr. Currey to be *Torrubia sinensis*); xxvii., On the Musci and Hepaticæ collected by Mr. H. N. Moseley, by Mr. W. Milten, F.L.S. (these were from Tenerife, Tristan d'Acunha, Kerguelen's Land, &c.)—On Algae collected by the Rev. W. W. Gill near the island of Mangara, by Dr. Dickie, F.L.S.—List of plants collected by Dr. A. B. Meyer in New Guinea, in 1873, by Prof. Oliver, F.R.S. (these were only ten in number, including two new species).—Mr. W. S. Mitchell made some additional observations on the male Octopus.

Chemical Society, April 15.—Prof. Abel, F.R.S., in the chair.—Mr. J. W. Thomas read a paper on the gases enclosed in coals from the South Wales basin, and the gases evolved by blowers and by boring into the coal itself. These gases were found to be marsh gas, carbonic anhydride, and nitrogen, in all three of the classes of coal examined, namely, bituminous coals, steam coal, and anthracite.—A paper on narcotine, cotannine, and hydrocotannine, Part I., by Mr. P. H. Beckett and Dr. C. R. A. Wright, was then read by the latter; after which Dr. H. E. Armstrong communicated a note on isomeric change in the phenol series.

Zoological Society, April 6.—Dr. E. Hamilton, vice-president, in the chair.—A letter was read from Dr. G. Hartlaub, stating that the Finch described by him and Dr. Finsch as new in the Society's Proceedings for 1870, p. 817, and named *Lobiotrogon notabilis*, was probably only the young bird of *Amblycra cyanocircus*.—Dr. A. Günther exhibited the skin of a new species of Mole from British Caffraria, which he proposed to call *Chrysochloris trevelyani*.—The Secretary exhibited, on behalf of Mr. J. Gould, F.R.S., the original specimen of the Parrot (*Aprosmictus insignissimus*), spoken of by Mr. Gould in his communication to the Society on the 3rd of November, 1874 (P.Z.S., 1874, p. 499); also specimens of two other new species of birds from Northern Queensland, a new Honey-eater, proposed to be called *Ptilotis flavostriata*, and a new Parrot, proposed to be called *Cyclopsitta maccoyi*.—Mr. Osbert Salvin, F.R.S., read a memoir on the avi-fauna of the Galapagos Archipelago. After a summary of what was known of the history and physical peculiarities of these islands, Mr. Salvin proceeded to give a complete account of the birds as at present known to us from the visits of Mr. Darwin, of the naturalists of the Swedish frigate *Engenic*, and of Dr. Habel, whose collection afforded the principal materials upon which the present communication was based. Of the fifty-seven species of birds known to exist in the Galapagos, about two-thirds were stated to be peculiar to the Archipelago.—Mr. A. G. Butler read a memoir on the Heterocerous Lepidoptera of the family Spingidae, in which a complete revision of the various genera and species of this family was given.—A communication was read from Dr. J. S. Bowerbank, entitled "A Monograph of the Siliceo-Fibrous Sponges," Part III., being the third of a series of memoirs on this class of sponges. A second communication from Dr. Bowerbank contained the seventh part of his contributions to a general history of the Spingidae.—Mr. A. H. Carter read a paper on the form of the trachea in *Tantulus ibis*, in which the peculiar and numerous convolutions of that tube within the thorax of that bird were described.—A communication was read from Mr. G. S. Brady, in which he gave a revision of the known species of British Marine Mites, together with descriptions of some new species.—Mr. C. A. Wright read a paper on the question of the

specific identity of the Weasel found in Malta, which he was inclined to refer to *Mustela boccamela*, Bp., hitherto only known to occur in Sardinia.

PARIS

Academy of Sciences, April 12.—M. Frémy in the chair.—The following papers were read:—On the comparison of the first observations of the Transit of Venus; a letter addressed by M. Puisseux to M. Dumas, President of the Transit Commission. From the data, M. Puisseux (NATURE, vol. xi. p. 474) finds the mean solar parallax to be 8"·870. This value differs little from that found by experiments on the velocity of light, made by MM. Foucault and Cornu, which is 8"·86; the latter is also the average value of those calculated by M. Leverrier from the perturbations of planets.—On the last number of the *Memorie di Spettroscopisti Italiani*, by M. Faye; this paper has special reference to M. Langley's memoir on the minute structure of the photosphere.—On the periodical variations and inequalities of the temperature (eleventh note); period of the twelve-fold twentieth day; by M. Ch. Sainte-Claire Deville. An extremely elaborate paper, with seven diagrams.—M. Cahours then presented to the Academy the third volume of his "Traité de Chimie Organique," and made some remarks on the same.—The Academy then nominated General Sabine as correspondent to their Section of Geography and Navigation, in lieu of the late M. Chazallon.—Researches on the transmission of air by a steam or air jet, by M. F. de Romilly.—On a new substance found in urine after the ingestion of chloral hydrate, by MM. Musculus and de Mermé. The authors gave it the name *urochloralate*, called.—A note by M. Bobierre, on the use of a little apparatus called *cherche-plomb* (lead-finder), which shows the presence of lead in alloys suspected of containing it, by contact with glacial acetic acid and iodide of potassium.—A note by M. G. Helzner, on an insect living, like Phylloxera, upon roots. It is principally found on *Abies balsamea* and *Abies Fraseri*.—M. R. de Vuoves reminds the Academy, upon the occasion of the interesting researches now published by M. Ch. Sainte-Claire Deville, that as far back as December 20, 1870, he presented to the Academy a memoir entitled "On the Periodicity of the Weather."—Calorimetric researches on the carbon compounds of iron and manganese, by MM. L. Troost and P. Hautefeuille.—On the preparation of ethylene perchloride, by M. E. Bourgoïn.—Researches on the quantities of heat disengaged in the decomposition by water of the bromides of some of the fatty acids, by M. W. Longuine.—On the determinations of the carbonic acid of the air made in the balloon *Zenith*, by M. G. Tissandier. The percentage of carbonic acid varied between 2·40 (at 890 metres elevation) and 3'00 (at 1,000 metres) volumes in 10,000 volumes of air.

BOOKS AND PAMPHLETS RECEIVED

COLONIAL.—Monthly Record of Results of Observations in Meteorology, Terrestrial Magnetism, &c., taken at the Melbourne Observatory during August 1874; Robert L. J. Ellery (Melbourne, John Ferris).—Geological Survey of Victoria. Observations of New Vegetable Fossils of the Auriferous Diffs; Baron Ferdinand von Mueller (Melbourne, John Ferris).

AMERICAN.—Observations on the Phenomena of Plant Life. Paper presented to the Massachusetts Board of Agriculture by W. S. Clarke (Boston, Wright and Potter).

CONTENTS

	PAGE
THE ANCIENT MONUMENTS BILL . . . . .	481
PRACTICAL PHYSICS ( <i>With Illustrations</i> ) . . . . .	482
DRESSER'S "BIRDS OF EUROPE" . . . . .	485
OUR BOOK SHELF:—	
"Monthly Journal of Education and Scholastic Advertiser" . . . . .	486
LETTERS TO THE EDITOR:—	
On the Dynamical Evidence of Molecular Constitution.—R. C. NICHOLS . . . . .	486
On the "Law of Fatigue" regulating Muscular Exertion, II.—Prof. SAMUEL HAUGHTON, F.R.S. ( <i>With Illustration</i> ) . . . . .	488
DENIGAUD . . . . .	489
OUR ASTRONOMICAL COLUMN:—	
The Sun's Parallax . . . . .	489
Tuttle's Variable Nebula in Draco, &c. . . . .	489
Comet 1766 (II.) . . . . .	489
THE SOLAR ECLIPSE . . . . .	490
ARCTIC GEOLOGY, III. By C. E. DE RANCE, F.G.S. . . . .	492
ON ATTRACTION AND REFUSION RESULTING FROM RADIATION . . . . .	494
THE FATAL BALLOON EXPLOSION. By W. DE FONVILLE . . . . .	495
NOTES . . . . .	496
ACCIDENTAL ASCENSIONS, III. By Prof. F. A. ABEL, F.R.S. . . . .	498
SOCIETIES AND ACADEMIES . . . . .	499
BOOKS AND PAMPHLETS RECEIVED . . . . .	500

THURSDAY, APRIL 29, 1875

## THE ISLAND OF ST. HELENA

*St. Helena: a Physical, Historical, and Topographical Description of the Island, including its Geology, Fauna, Flora, and Meteorology.* By John Charles Melliss, A.I.C.E., F.G.S., F.L.S. (London: L. Reeve.)

“THERE is a change to be introduced into our mode of work as compared with that of former investigators. When less was known of animals and plants, the discovery of new species was the great object. This has been carried too far, and is now almost the lowest kind of scientific work. The discovery of a new species, as such, does not change a feature in the science of natural history any more than the discovery of a new asteroid changes the character of the problems to be investigated by astronomers. It is merely adding to the enumeration of objects. We should look rather for the fundamental relations among animals; the number of species we may find is of importance only so far as they explain the distribution and limitation of different genera and families, their relations to each other and to the physical conditions in which they live. Out of such investigations there looms up a deeper question for scientific men, the solution of which is to be the most important result of their work in the coming generation. The origin of life is the great question of the day. How did the organic world come to be as it is?”

This passage, quoted by Mr. Bentham in his address to the Linnean Society for 1868, from an instructional lecture given by Agassiz on the voyage out to his young companions in his Brazilian expedition, sums up the grounds on which writers of books on systematic natural history must now be prepared to have their work criticised. It is no longer enough to publish, however sumptuously, bare enumerations of the organisms which inhabit some spot of the earth's surface. No treatment can be really considered scientific which does not go a good deal further, and, regarding the fauna and flora of a country as phenomena to be accounted for, endeavour to unravel their causes, history, and relationships. No one has shown with more penetration and success than Mr. Bentham, what important and interesting general results may be deduced from the most apparently arid fields of systematic investigation. But it is only the gradual elucidation of such results that really affords anything like a scientific sanction to this kind of study, and it is because this has in many cases been very much lost sight of, that taxonomy—especially on the Continent—has fallen into a disrepute which is just as unscientific and unphilosophical as a morbid appetite for taxonomic studies unqualified by any search for results of general biological interest.

It will now perhaps be apparent why this stately octavo which Mr. Melliss has devoted to the natural history of St. Helena does not yield either the kind or amount of satisfaction which a cursory inspection might lead one to expect. It is quite true that science owes a great debt to Mr. Melliss for carefully collecting the extremely interesting forms of life which St. Helena possesses, and which from one cause or other are rapidly disappearing. But his gatherings have been already worked up by different naturalists, and the results published in various scientific

journals. The mere enumeration of genera and species which he gives in these pages, with occasional remarks, is not by any means interesting reading, and is of course but of very small use for any purpose of reference.

The first of the five parts into which the book is divided is occupied with the history of the island. It was discovered in 1502 by John de Nova Castella, commanding a Portuguese fleet on its return from India. The day being the anniversary of Helena the mother of Constantine, the island was named St. Helena in her honour. The Portuguese left on the island a supply of goats, asses, and hogs, and in this way commenced at once the gradual extirpation of the indigenous flora which has since never ceased to proceed. The Portuguese for a time had a settlement, which they appear soon to have deserted. The Dutch next took possession, only in turn to abandon it, after which it was occupied about the middle of the seventeenth century by the East India Company. Twice, however, in the next quarter of a century it was again taken possession of by the Dutch, to be again retaken from them by the English.

St. Helena never appears to have had any internal source of independent income. The population lived by supplying the needs of the garrison, the “Liberated African depot,” the West African squadron for the suppression of the slave-trade, and the passing eastward-bound ships. The garrison is now represented by a handful of Engineers and artillerymen, the depot is abolished, the squadron reduced, and the trade to the east is almost entirely diverted through the Suez Canal. No articles for export are produced; the “natives” prefer to live on imported rice; the farmers barely exist on their deeply mortgaged properties. Yet the soil, composed of volcanic débris, is undoubtedly productive, and, were it tilled with even moderate energy, might yield profitable returns. The cultivation of *Cinchona* has been encouraged by the home Government, but has been treated with entire apathy by the colonists. The population, amounting to 6,860 in all, consists of the “yam stalks,” or “natives” proper, the descendants of the slave population liberated in 1832; they are of mixed origin, partly European, partly Asiatic. The West African negroes form about a sixth of the whole population; they were introduced from the captured slavers, and form settlements apart from the “natives.” The white inhabitants consist of the Government officials, the garrison, and merchants and farmers.

The history of the colony contains little of any interest. The *ennui* of island life was probably the exciting cause of several mutinies. In the first, in 1693, the governor was murdered, but the lieutenant-governor was equal to the occasion, and stamped out the conspiracy which was spreading among the black slaves. Amongst other repressive measures one of the ringleaders “was hanged alive in chains and starved to death.” Mr. Melliss apparently approves of this, and compares it with “Governor Eyre's prompt measures.” Of course there is a good deal to say about Napoleon—the house in which he lived, and the mode in which he was buried.

Part II. treats of the Geology and Mineralogy. It does not appear to add anything essential (unless we except the stupid story about “the apostate friar”) to the admirable account given by Mr. Darwin in his “Volcanic

Islands," which Mr. Melliss does not appear to have seen. The volcanic bombs figured on Plate 14 would seem to be much more probably explained as examples of spheroidal weathering. Nor does the view of the curious dike called the "chimney" (Pl. 17) give any more indication than the text (p. 72) of its very curious structure. This is described and figured in Lyell's "Elements" (p. 610), from Seale's "Geognosy of St. Helena," which also seems to have eluded Mr. Melliss's attention.

Part III. is occupied with the Zoology, beginning with *Homo sapiens*, Linn., and finishing with the *Spongida*. The list is swelled in every possible way, and a variety of information which is, to say the most, hardly more than "curious," is given under the different heads. Under *Mus decumanus*, Linn., we are told "that it is a fact that one of these noxious animals" sprung out of Napoleon's that when he was about to put it on after dinner. *Canis familiaris*, Linn., suggests, on the principle of concomitant variations, that the neglect of their education is the reason of the absence of hydrophobia in St. Helena dogs. *Equus caballus*, Linn., introduces the governor's "modern carriage and pair of Hyde Park." The account of the *Celacea* is still more trivial. Mr. Harting's account of the endemic land-bird *Egialitis sancta-helena* is given, and an enumeration of the other introduced and indigenous species. But Mr. Melliss does not say anything about the fossil eggs found in the beds of limestone by Mr. Darwin and also written upon by Buckland. The fish have been described by Dr. Günther, and the *Mollusca* by Mr. Gwynn Jeffreys; but only the names are enumerated. Some further confirmation would seem to be needed of the suggestion that the extinct *Bulimus auris-vulpina* bored the holes found in the marl on the upper part of the island. The insects have passed through the hands of various entomologists: Mr. Wollaston has published an account of the Beetles, Mr. Cambridge of the Spiders. Excluding the cosmopolitan species which have been manifestly introduced, the St. Helena list of *Coleoptera* "possesses," according to Mr. Wollaston, "nothing whatever in common with those of the three Sub-African archipelagos which lie further to the north—though the great development of the Curculionideous sub-family *Cossonides* is a remarkable fact which is more or less conspicuous throughout the whole of them." With regard to the other groups there is no summary or comparison of distribution; in fact, little more than a bare enumeration of species.

White ants were introduced into the island in 1840 in some timber from a slave-ship. Mr. McLachlan has identified the species as *Termites tenuis*, Hagen, peculiar to South America. The mischief which it has done is almost incredible, and it appears to have simply gradually destroyed the whole of Jamestown. A considerable portion of the books in the Public Library, especially theological literature, was devoured by them, and the whole of the interior would be destroyed without the exterior of the volumes seeming otherwise than intact.

The flora of St. Helena is one of extraordinary interest. When the island was discovered it was covered with arboreous vegetation. Notwithstanding the belief of the botanists of the United States Exploring Expedition under Wilkes to the contrary, there seems no reason to doubt the existence of the forests, or that their

destruction during the past 360 years has been almost entirely effected by the goats introduced by the Portuguese. The old trees gradually died, the young ones were barked, and the seedlings were browsed down. In this way all knowledge of a large part of the flora has been completely lost. Even since the beginning of the present century several species have become extinct, while many were more abundant than which are only represented now by single individuals. Fortunately, however, the flora has been examined by several botanists. Burchell spent five years in the island from 1805 to 1810, and although he published no results he made a large number of drawings and collected excellent specimens. Roxburgh subsequently made a list of St. Helena plants, and the island has also been twice visited by Dr. Hooker. Had collections been made during the last century, more of its extinct endemic species would no doubt be known, but the forms that we are acquainted with are extremely interesting.

Mr. Melliss swells the list of flowering plants to 880. But this is accomplished by including every kind of plant introduced into or cultivated in the island. Spring and winter wheat, the sugar-cane, and garden vegetables such as cabbages and turnips, are all enumerated in precisely the same type as the remnants of the peculiar endemic flora. Mr. Melliss quotes freely from Dr. Hooker's interesting address at the Nottingham meeting of the British Association on Insular Floras, but he altogether omits giving any distinct list of the indigenous as apart from the introduced plants. By carefully going over his pages it is possible to frame such a list, and it appears to contain thirty-one flowering plants. Of these, except *Commidendron* (*Aster*) *glutinosum*, which occurs at Ascension, and *Cynodon dactylon*, which is widely diffused in the tropics, the whole appear to be absolutely restricted to this minute speck of the earth's surface. They have, moreover, all the aspect of a very ancient vegetation. Exactly one-third of the species are *Compositae*, but nine out of the ten are shrubs or trees, a most unusual habit of a growth in an order where the vast proportion of the species are annuals or die down to the ground every year. Mr. Darwin has pointed out the significance of this:—

"Islands often possess trees or bushes belonging to orders which elsewhere include only herbaceous species; now trees, as Alph. De Candolle has shown, generally have, whatever the cause may be, confined ranges. Hence trees would be little likely to reach distant oceanic islands; and an herbaceous plant, though it might have no chance of successfully competing on a continent with many fully developed trees, when established on an island and having to compete with herbaceous plants alone, might readily gain an advantage over them by growing taller and overtopping them."—*Origin of Species*, 4th ed., p. 467.

Not less singular than the testimony to long isolation borne by the habit of the species is the extremely obscure geographical relations of the flora. Any amount of adaptive differentiation would be intelligible. But what is not easily explicable is the want of relationship of the species to those of adjacent continents. The connections are really far more remote. Mr. Bentham has made some remarks upon this in his elaborate paper on the *Compositae* (*Journ. Linn. Soc.*, vol. xiii. p. 563):—

"*Commidendron* [to which genus Mr. Bentham refers

the three species of *Aster*] and *Melanodendron* are among the woody Asteroid forms exemplified in the Antarctic-American *Chilotrachium*, in the Andine *Diplostegium*, and in the Australasian *Olearia*. *Petrobium* is one of three genera, remains of a group probably of great antiquity, of which the two others are *Podanthus* in Chili, and *Astennia* in the Andes. The *Psiodia* is an endemic species of a genus otherwise Mascarene or of Eastern Africa, presenting a geographical connection analogous to that of the St. Helena *Melhania* of De Candolle with the Mascarene *Trochetia*."

In many of the other constituents of the flora—*Mesembryanthemum*, *Pelargonium*, *Phyllis*, *Lobelia*, *Wahlenbergia*, there is an obvious connection with the South African flora. But the changes in the physical geography of the Old World must have been very considerable, since the Mascarene Archipelago and St. Helena received their vegetation from any common source.

Questions of this kind, which are the real matters of interest about St. Helena from a biological point of view, Mr. Melliss scarcely touches, or quite inadequately. And this is the more tantalising, as so large a body of undigested information has not hitherto been brought together about any oceanic island. Here and there significant facts of the same kind may be gleaned from the lists of the fauna. Thus a beetle, *Stenoscelis hylastoides*, Woll., appears to be peculiar to the Cape and to St. Helena; *Bulimus helena*, Quoy, is a Mascarene and East African type; while the great *B. auris-vulpina*, Chemn. (now, like the last, extinct), belongs to a group peculiar to Tropical America.

Apart from these points, the mere history of the vicissitudes which the animal and vegetable life of the island has gone through since the Portuguese first visited its forest-covered but now denuded hills, forms a striking series of episodes in the general struggle for existence. What the goats forbore to browse, introduced plants like the blackberry strangled. It would seem as if strenuousness died away among assemblages of organisms, which had established a *modus vivendi* amongst themselves. Rude impulses from without, when at last the isolation is broken, achieve a comparatively easy victory. One cannot fail noticing the uniformity of language with which this is described, whether the invasion takes the shape of goats, blackberries, white ants, measles, or even dissent, which, "introduced by a Scotch Baptist minister about the year 1847, soon spread" (page 33).

The fifty-six plates with which the volume is illustrated deserve a word of notice. Thirty-one of these are effective illustrations of the plants from the drawings of Mrs. Melliss, with dissections from those by Burchell in the possession of Dr. Hooker. A large proportion of the most curious of the St. Helena plants have been figured by Dr. Hooker in the *Icones Plantarum*, but that is a somewhat inaccessible publication, except to botanists, and the present series of botanical plates really gives the present work its chief interest.

W. T. T. D.

#### HEREDITY

*Heredity: a Psychological Study of its Phenomena, Laws, Causes, and Consequences.* From the French of Th. Ribot. (Henry S. King and Co., 1875)

IF M. Ribot intended this work to be regarded as an original contribution to the philosophy of evolution, it is impossible to consider his efforts successful. He

styles the book a "Psychological Study," and he shows therein an intimate acquaintance with the writings of all the principal authors who have created the new philosophy. Darwin, Spencer, Bain, Galton, Lucas, and some others are constantly appealed to, or made to contribute to his pages. M. Ribot has further collected from older writers, and from medical works, a great number of facts, often more curious than authentic, bearing upon the question of heredity. He has composed a very readable and interesting essay on the subject, of a semi-popular character, and no doubt there is plenty of room for such a work, epitomising and presenting in a connected form the great abundance of facts and generalisations already accumulated upon this subject. But it is difficult to regard the work as more than a compilation, and there are several important deficiencies which may be pointed out.

I should have liked to meet in the book some clear and consistent view as to what heredity really means, but M. Ribot's ideas seem to waver. At the outset (p. 1) he says: "Heredity is that biological law by which all beings endowed with life tend to repeat themselves in their descendants. . . . By its nature ever copies and imitates herself. Ideally considered, heredity would simply be the reproduction of like by like." In many other passages he repeats, no doubt correctly, that heredity is the generation of like by like. Any feature in a living being which is not found in any one of its ancestors cannot be called hereditary. From similar conditions follow similar effects. Thus, if heredity had been the sole influence moulding living beings, we must all have had exactly the same features and characters.

In other passages M. Ribot takes an opposite view, and speaks of heredity as the cause of difference. In p. 387 he concludes that "heredity is really, therefore, partial identity," and he adopts a solution of the question "which attributes to heredity a creative part." This view he explains as follows (p. 34):—"In the hypothesis of evolution, heredity is really creative; for since, without it, it is impossible for any acquired modification to be transmitted, the formation of instincts, properly so called, however slightly complex, would be impossible." Again, he says (p. 344): "If with the evolutionists we recognise in heredity a force which not only preserves, but which also creates by accumulation, then not only is the character transmitted, but it is the work of fate, made up bit by bit, by the slow and unconscious but ever accumulating toil of generations." In pp. 302-3 he distinctly speaks of heredity as an indirect cause of decline, acting by way of accumulation. A few pages later (p. 306) we are informed that the first consequence of heredity is to render possible the acquisition of new instincts. Surely there is a confusion of ideas in these statements.

As M. Ribot in other places fully explains, the conditions governing the form and character of a living being may be classed under three heads: (1) Heredity, by which we mean the transmission of like characters from parent to offspring; (2) The influence of surrounding objects—the environment, as Spencer calls it; (3) Spontaneity, by which some writers have denoted the inexplicable variation of the offspring from the type of their ancestors. Two meanings, however, may be attributed to spontaneity: it may mean *causeless* variation, change

independent of prior conditions, in which case it is removed from the sphere of law altogether, and becomes miraculous; or it may mean a distinct tendency to variation inherent in the offspring, and impressed upon it by the parent. In the latter case, however, spontaneity is really hereditary; and only appears to be spontaneous because it is the disclosure of a previously hidden power. M. Ribot fails, so far as I can find, to discriminate these meanings. He rejects the notion of spontaneity as wholly unscientific, but does not observe that the original life-germ must have contained inexplicable powers enabling it to develop into many forms. The seven hundred or more crystalline forms in which calcite is said to be found, must be explained partly by the intimate constitution of a molecule of carbonate of lime, partly by the environment in which it became crystallised. So we must attribute the almost infinitely varied forms of animal life partly to environment, but partly to the inexplicable powers of development impressed upon certain particles of protoplasm.

M. Ribot's reasoning is of doubtful soundness, again, when he speaks of heredity as the *cause* of decline in nations, or the cause of the production of new instincts. So far as the child is like its ancestors, there cannot on the average be either progress or decline. If certain individuals have, from unexplained causes, deviated from the previous type, it is impossible that their offspring should resemble completely both the previous and the new type. The contradictory features of different ancestors cannot possibly be made manifest in the same child; therefore the law of heredity must appear to fail in one way or the other. When a superior race intermarries with an inferior one, and becomes degraded, heredity simply perpetuates the inferior type by what Mr. Darwin calls *prepotency*; a term, by the bye, which M. Ribot should have adopted.

It cannot be said that M. Ribot is alone responsible for the want of consistency in his views of heredity. There are still some who believe in spontaneous generation; there are others who would have us believe that ordinary chemical agencies have developed a lifeless particle of protoplasm into a living particle, which became the germ of the animal and vegetable kingdoms. Mr. Darwin, so far as I remember, nowhere goes back to such insoluble questions. Sir W. Thomson suggests that the germ came from other parts of space. How far Mr. Herbert Spencer's philosophy affords a real solution of the question it must probably remain for another generation to decide. All that I wish to point out is, that so highly intelligent and careful a student of all that has been written on the philosophy of evolution as M. Ribot has certainly failed to acquire clear notions concerning the relations of heredity, spontaneity, and the influence of environment.

The most important result of M. Ribot's arguments is perhaps the support which he brings to Mr. Spencer's views of the origin of moral sentiments and rules. The last few chapters in which he treats of the moral consequences of heredity are particularly interesting. It becomes evidently impossible to uphold any longer the views of the older utilitarians, from Locke down to the two Mills and Buckle. As M. Ribot remarks, it is surprising to find a writer such as Buckle attributing little importance to psychological heredity. It is impossible

any longer to look upon the mind and moral nature of the child as a *tabula rasa*, which can be marked by education at our will. If so, Mill's views of the philosophy of morals fall to the ground, and the doctrine of the moral sense in a modified form must be again taken in hand.

As a general rule, M. Ribot appears to acknowledge with sufficient candour his indebtedness to various authors. An exception is to be found in the case of Mr. Galton. It is true that Mr. Galton is quoted from time to time, but sometimes in a slighting manner; whereas the extensive obligations under which M. Ribot lies towards Mr. Galton will be apparent to anyone who is acquainted with the work on "Hereditary Genius" of the latter author.

W. STANLEY JEVONS

### OUR BOOK SHELF

*Animal Physiology.* By John Cleland, M.D., F.R.S. Advanced Science Series. (Wm. Collins, Sons, and Co.)

HUMAN Physiology being in a great measure based upon investigations conducted on the lower Vertebrata, all works on the subject may, in a certain sense, be considered to be on "animal" physiology. The small treatise before us agrees, as far as the nature of the points treated of, very much with most works of the same size on human physiology. Incidental mention is no doubt made of the most important peculiarities of the nervous, circulatory, digestive, and other systems in the lower Vertebrata, but these are incomplete, and sometimes inaccurate. As an introduction to physiology, Dr. Cleland's work, however, possesses many advantages. It is written for readers previously unacquainted with anatomical details, and this class of students is daily becoming more numerous, although it is generally felt that no considerable progress can ever be made in the subject except on an anatomical basis. The illustrations are also numerous, whilst many are original and excellent. The manner of expression is particularly simple and clear, all the technical terms employed being carefully explained. In the earlier part of the work, in the chapter on alimentation, there is an argument on which particular stress is laid, which is, that as animals have no power of manufacturing organic matter from the materials found in organic nature, but feed either directly on the vegetable world or on other animals which have fed on vegetables; and as in plants the power of building organic matter is confined to the green parts, "the statement may therefore be ventured on that, so far as observation has yet proceeded, it would appear that the presence of chlorophyll is as necessary for the production of organic matter in organisms as the presence of protoplasm is necessary for growth." The full bearing of this fact is, no doubt, not yet fully understood. On the whole, we think that the author has fully succeeded in producing a work which, from the grouping of its facts, is decidedly more than a mere collection of details.

*Fifth Annual Report of the Association for the Improvement of Geometrical Teaching.* (January 1875.)

THE Association, it may be remarked, is almost coeval with this journal, for it was in the early numbers of NATURE that a correspondence was started on the subject of Geometrical Teaching. This resulted, as our readers are aware, in the formation of the Association. After four years of continuous work, two of which have been devoted to the difficult subject of Proportion (as we learn from the Report), the Syllabus of Plane Geometry is now complete; and, after a few verbal alterations



possibly have been made, it will be forwarded for criticism to the Committee (on Geometrical Teaching) of the British Association and to other mathematical authorities. The object, we further learn, is, if possible, to get the sanction of the British Association; and this backing the opinion of the large number of mathematical teachers who now form the Association, will, it is hoped, lead the examining bodies of the country to act with perfect impartiality in considering the merits of those pupils who have been trained in accordance with the methods of the Syllabus as contrasted with the favourers of Euclid.

From the Report we gather that the principal work of the Association is expected to be completed in another two years; it is not attempted to forecast what will be its subsequent work. Perhaps, as has, we believe, been suggested, it may become an Association for the Improvement of Mathematical Teaching.

As the publications of the Association are for private circulation, we cannot go into further detail; we may, however, say that it has done good work in having been the moving cause of five valuable Presidential Addresses.

### LETTERS TO THE EDITOR

[The Editor does not hold himself responsible for opinions expressed by his correspondents. Neither can he undertake to return, or to correspond with the writers of, rejected manuscripts. No notice is taken of anonymous communications.]

#### Influence of Pigments on the Photographic Image of the Spectrum

WHEN, some time since, Prof. H. Vogel announced the discovery that the addition of a pigment to a film of bromide of silver made it sensitive to light of the colour which that pigment gave it, though it had not been so previously, many—indeed I might say most—photographic chemists doubted the accuracy of his observations and the existence of any such law. His experiments were rehearsed by most of them, and the reports were, in almost every case, contradictory of his conclusions. There were powerful *à priori* reasons for doubting, amongst which the chief was, in my own opinion, that if a film coloured (say) red were sensitive to red light, it could not be developed under red light, but would fog, and would therefore be unworkable, which was not found to be the case. Another was, that the use of tinted films, well known for a long time, had only resulted in an universal retardation of all colours. It was, moreover, contrary to the known analogies of actinism that a purely mechanical admixture irrespective of any chemical quality should produce changes of so purely chemical a nature as those which are the basis of photographic action.

By the kindness of Mr. Lockyer I was enabled to experiment at his laboratory at South Kensington with the same plates (Col. Wortley's tinted films) that Prof. Vogel had based his discovery on, and, as I expected, found the results quite other than those the professor had announced. Although a protracted exposure (seventeen minutes) was given, and the more refrangible lines were quite buried by halation, no line was shown which did not appear in the ordinary wet collodion film.

That careful and excellent photographic chemist, Mr. Spiller, President of the London Photographic Society, Dr. Van Monckhoven, Mr. Carey Lea, and numerous others, amongst whom I am enabled, by his personal assurance, to name Dr. J. W. Draper, unquestionably the first living authority on spectrum photography, as well as his not less well-known son, Prof. Draper, have also followed Vogel in his experiments without obtaining any confirmation of his law.

Up to this time the only testimony confirmatory of his views offered is that of Becquerel, who, as the most marked instance of success, gives this—that chlorophyl (a green substance) gives great sensitiveness to red rays! That most indefatigable and precise experimentalist, Mr. Carey Lea (of Philadelphia, U. S. A.), in the course of a long series of experiments, unfortunately interrupted by his ill-health, showed that while coralline in a film did add slightly to the length of the spectrum image, other red pigments produced no effect whatever, and that salicine, which has no colour, produced more effect than coralline. But if chlorophyl, a green substance, is sensitive to red

light, aniline green, so far as my own experiments go, produces no effect whatever except prolongation of the exposure necessary.

Now, without in the least disputing the prolongation of the spectrum photograph as claimed by Prof. Vogel, or depreciating the importance of his results, it seems to me that we are in a position to assume that he is entirely mistaken in the nature of the law he deduces, and that these results are due to purely chemical causes, in no wise dependent on colour, though in a few cases the colour may coincide with the chemical cause in such a way as to afford apparent confirmation of his hypothesis.

It must be remembered that Dr. Draper has long ago shown that all the rays have chemical activity, and that he has, without any such aid as Vogel has called in, produced complete photographic spectra; and has also shown that different substances decompose under different rays. Becquerel's experience with chlorophyl gives a clue to the connection between these discoveries and Vogel's results, if collated with a series of phenomena resumed by Dr. Draper (from observations by Dr. Gardner) in the interesting papers by him on the "Distribution of Chemical Force in the Spectrum" &c. &c.—"In Dr. Gardner's paper there are also some interesting facts respecting the bleaching or decolorisation of chlorophyl by light. He used an ethereal solution of that substance:—'The first action of light is perceived in the mean red rays, and it attains a maximum incomparably greater at that point than elsewhere. The next part affected is the indigo, and accompanying it there is an action from +10°5 to +36°0 of the same scale (Herschel's), beginning abruptly in Fraunhofer's blue. So striking is this whole result, that some of my earlier spectra contained a perfectly neutral space from -5°0 to +20°5, in which the chlorophyl was in no way changed, whilst the solar picture in the red was sharp and of a dazzling white. The maximum in the indigo was also bleached, producing a linear spectrum as follows:—



in which the orange, yellow, and green rays are neutral. These, it will be remembered, are active in forming chlorophyl.' . . . I have quoted these results in detail, because they illustrate in a striking manner the law that vegetable colours are destroyed by rays complementary to those that have produced them, and furnish proof that rays of every refrangibility may be chemically active." (P. 7, "Researches in Actinic Chemistry.")

Dr. Draper goes on in this memoir to establish a second proposition to this effect:—"That the ray effective in producing chemical or molecular changes in any special substance is determined by the absorptive property of that substance." This proposition, laid down in 1841, seems to me to contain the explanation of all the phenomena of chemical or molecular change in photographic films; and if I might be permitted to offer an hypothesis supplementary to the proposition, serving, if demonstrable, as corollary to it, it would be that if two substances having different absorptive properties are simultaneously (or nearly so) subjected to the action of white light, in molecular contact the change in one of them may be communicated to the other mechanically. Thus, bromide of silver, which is not sensitive to the red ray, being placed in contact with chlorophyl, which is sensitive to that colour, the action of the red ray is communicated from the latter to the former substance, producing what may be designated as a sympathetic molecular effect. But in order that this may obtain, it is necessary that the auxiliary substance applied to influence the sensitive photographic film should be in itself sensitive to other rays than those which decompose the silver bromide. This would account for the effect of chlorophyl and perhaps for the original experiment which attracted the attention of Prof. Vogel, as the dry plates of Col. Wortley with which it was made contain salicine in their preservative as well as an aniline red in their substance, and Mr. Carey Lea has shown that salicine has the effect which Vogel claims for the colour.

If this is tenable, it follows that the object of our researches should be to discover those substances which have an independent susceptibility to actinic action, but for different rays than those which form the basis of the film experimented on. The results so far obtained in this direction, even those of Vogel himself, are, it seems to me, quite as capable of explanation by the hypothesis I have offered as by that of an arbitrary effect of colour; in confirmation of which we have only experiments (thus far made public) by Prof. Vogel himself.

It seems to me incredible that, if such a law existed, such

\* "Researches in Actinic Chemistry, Memoir Second," &c. John William Draper, M.D., LL.D., New York.

careful and experienced investigators as the Drapers, Von Monkhoven, Spiller, Carey Lea, and others who have repeated Prof. Vogel's experiments, should utterly fail to obtain any confirmation of his hypotheses; and there is no solution in accordance with known facts and analogies of actinic action except to conclude with Dr. Draper that Prof. Vogel has made a mistake—he has attributed to one of two coincident qualities of certain substances effects which are due to the other.

Dr. Draper records experiments in which he secured a photograph of the entire spectrum on a daguerreotype plate, by availing himself of the singular reversing action of light on the impressed plate (pp. 2 and 3 of memoir), and allowing a diffused daylight to fall on the plate simultaneously with the spectrum image. "If," he says, "a spectrum be received on iodide of silver formed on the metallic tablet of the daguerreotype, and carefully screened from all access of extraneous light, both before and during the exposure, on developing with mercury vapour an impression is evolved in all the more refrangible regions.

"But if the metallic tablet during its exposure to the spectrum be also receiving diffused light of little intensity, as the light of day or of a lamp, it will be found, on developing, that the impression differs strikingly from the preceding. Every ray that the prism can transmit, from below the extreme red to beyond the extreme violet, has been active. The ultra-red heat lines a  $\beta$   $\gamma$  are present."

The whole of this memoir is of the greatest interest to the spectroscopic photographer, not only as giving the result of all previous experiment in this field, but in clearly marking out what remains yet to do in it. The subsequent success of the younger Draper in obtaining a negative of the spectrum complete by the ordinary collodion process, through the aid of an analogous system of protection by mechanical means for the lines most readily impressed, proves that even with silver, and under any condition of process, we have the power of recording any spectroscopic phenomenon; but if experiment should prove that substances in themselves liable to decomposition by rays which do not attack the salts of silver are capable of communicating an impression by molecular contact to the silver, and inducing decomposition in it, it is evident that a complete combination may be arrived at which, without mechanical contrivances, will give us printing negatives of the spectrum throughout.

W. J. STILLMAN

#### Dr. A. B. Meyer and his Critics

NOT until now have I found leisure to look through the pages of NATURE for the years 1873 and 1874, and therefore it was not till now that I became aware of two letters in your correspondence (December 11, 1873, p. 102, vol. ix., and April 23, 1874, p. 482, vol. ix.), which concern me, and in answer to which I beg leave to say a few words.

The first is written by Mr. Wallace, and is about a wrong opinion which I had formed on this author's notion as to the relation of the inhabitants of the Arfak Mountains on New Guinea to the inhabitants of the coast. I am glad to see that Mr. Wallace and I agree in the conviction of the identity of those two groups of Papoos; but nevertheless I am anxious to show that my misunderstanding of Mr. Wallace's opinion was based upon an apparently clear expression in his valuable work on the "Malay Archipelago," which I took, as I believe, not in the restricted sense in which the author perhaps wished it to be understood. Mr. Wallace did not succeed in finding the passage in his work on which I had based my idea; but he just rebuffed off his quotation where the words begin to which I referred: "Their hair, though always more or less frizzly, was sometimes short and matted," &c.; so far Mr. Wallace cites his own words, but the sentence (page 310, 1st ed.) goes on, "instead of being long, loose, and woolly; and this seemed to be a constitutional difference, not the effect of care and cultivation." These last words then led me to the opinion in question. In a paper in the *Mittheilungen der Anthropologischen Gesellschaft zu Wien* ("Anthropologische Mittheilungen über die Papuas von Neu Guinea; I. Ausserer physischer Habitus"), 1874, page 92, I quoted myself the whole passage, and dealt with the object more in particular. That it is still the general opinion that a difference exists between the Arfakis and the Papoos of the coast is proved, e.g., by a notice of that paper in M. Broca's "Revue d'Anthropologie," vol. iii., 1874, page 729: "Notre voyageur n'admet pas non plus qu'il y ait entre les tribus du bord de la mer et celles des montagnes—les Arfakis—les différences constitutionnelles observées cependant par la plupart des voyageurs," &c.

The other letter contains a protest of Signor D'Alberis against my having "led the public to believe that he had claimed for himself the honour of crossing New Guinea from one coast to the other." Signor D'Alberis cites my paper in NATURE, vol. ix. p. 77, where he states he has read an assertion of mine concerning this point. But I look in vain through my whole article to find one single word to the purpose, and therefore I do not understand what induced that intrepid co-operator to publish his protest. I only mentioned (page 79): "I need not say that this journey from one side of New Guinea to the other has never been made before, and I should hardly myself attribute any importance to the fact," &c. A. B. MEYER

#### The Chesil Bank

THE letter of your correspondent, Col. Greenwood (vol. xi. p. 386), has only now been brought under my notice.

There is one fallacy contained in it which no one would detect more easily than Col. Greenwood, if he were but to visit the Portland end of the Chesil Bank. He would then see for himself that Portland Island does not act as a groin in accumulating the pebbles that form the beach.

The Chesil Bank extends from Portland to Bridport Harbour, where it is composed of small pebbles or gravel of the average size of horse-beans. It is there a true beach of considerable breadth and depth, and does not merge into sand until it arrives at a point beyond the mouth of the harbour. Following it towards Portland, it runs along under the cliffs by Barton, Swyre, &c., to Abbotsbury, where it assumes its distinguishing characteristic of a pebble ridge, washed by the sea on one side and by the waters of the Fleet estuary on the other. From thence it proceeds to the Ferry bridge, where it meets the waters of Portland Roads (from which, however, it is separated by a stretch of sand of varying width), and from thence to Portland.

Its direction after leaving Abbotsbury is W.N.W. and E.S.E. very nearly. On reaching Portland it takes a sharp curve to the west and forms the little bight called Chesil Cove, and it is here that the ridge begins to decline in height, and the pebbles, that up to this point have been gradually increasing in size, commence to diminish in bulk. A line stretched seawards from this point at right angles with the shore would point W.S.W.

The decline is rapid, so that in a distance of about 250 yards the bank tails out to nothing at the point where it touches, and does but just touch, the Undercliff.

There are probably several causes at work in bringing about this abrupt termination of the Chesil Bank. Among them I should reckon as most effective the curvature of the bank at Chesil Cove, whereby the beach is exposed at such an angle to the waves caused by the prevailing S.W. wind that the progressive action of the W. and W.N.W. winds is neutralised; secondly, the peculiar set of the tides round the Bill at Portland; and thirdly, the progressive action of the W. and W.N.W. winds being diminished or nullified by the curvature.

There cannot be the slightest doubt that the march of the pebbles is from Bridport to Portland, and that any movement in the contrary direction is due to temporary causes only.

That the larger pebbles travel over the heads of the smaller when the waves strike the beach at an angle is not merely proved in theory, but a fact demonstrable by experiment, as was announced by Sir John Coode in his elaborate paper on "Sea-Beaches" (*Phil. Trans.* 1834).

As to the materials of the beach having been partly derived from the destruction of the ancient raised beach, the remains of which are to be seen at this day in Portland, I would remark that, according to the account given by Leland in his "Itinerary," Portland at the time of his visit was of nearly the same dimensions as now, though tradition reports that the site of the old church was once the centre of the island, the shifting bank of sand and shells called the Shambles being its eastern boundary. Any pebbles derived from the intervening raised beach have in all probability been ground by the continual pounding of the Atlantic billows into sand long before this—probably before the time of Leland. Yet he states, with reference to the Chesil Bank, "that as often the wind bloweth strenue at south-east (? west) so often the se beith it, and losith the bank, and breakith through it;" indicating that the bank was not so strong then as it is now; for such a thing has not occurred within the memory of living man, not even on the occasion of the "Outrage" in Nov. 1823, when the crown of the bank was swept off by a tremendous gale, and spread over the sands on the other side of the ridge; and when the fishermen's houses, that for centuries probably had nestled



centre of the earth, the first external contact occurred on December 6, at 15h. 47.8m. Greenwich mean time, at 35° from the north point of the sun's disc towards E. for direct image, and the last external contact at 18h. 26.8m. about 4° towards W. At Paris the final contact took place at 17h. 50.3m. local mean time, but the sun did not rise till 19h. 39m.; the planet therefore had left his disc less than fifty minutes before he was on the horizon of Paris.

### ARCTIC GEOLOGY\*

#### IV.

*Vardö Island*, † at the end of a long promontory in the polar basin, is described by Mr. Campbell, of Islay, ‡ as consisting of metamorphic slates, dipping at 45°, and striking with the hollows and ridges north and south, ground into shape by ice, but since submerged and wave-worn; drifts packed and rolled by the sea are left in a grass-grown raised beach at 60 feet, a peat-covered beach at 100 feet, and rolled stones occur on the summit level of the island, 220 feet above the sea, resting on red sandstones, with fossil markings in concentric rings. At 30 feet above the sea occurred a "storm beach," with large and sub-angular stones, sweeping in a crescent round the bay, the fortress of Vardö, and the church of Vadsö. He describes it as built on coral sand, and refers to the warm equatorial current affecting the climate in the polar basin to lat. 80° in Spitzbergen, and to long. 66° E. in Novaya Zemlya, which enables a luxuriant vegetation to live on the shore at Yeredik, about 70° N., in spite of the winter's darkness.

The most northern island of Novaya Zemlya has been called Castanjö by Capt. Mack, from the "Mimosa beans" or chestnuts found there, which tropical brown nuts in Spitzbergen reach 20° E.; § but Mr. Lamont considers the large quantities of drift wood found on that coast to be derived from pines (*Abies excelsa*) that have grown on the banks of the large Siberian rivers; || and states that when wood occurs inland it is associated with bones of whales. He therefore does not agree with Lord Dufferin that it is brought to Spitzbergen by the Gulf Stream, ¶ which Mr. Lamont states has no influence north and east of Black Point and the Thousand Isles, even during June, July, and August, while during the winter months ice-laden currents sweep round Spitzbergen on both sides from the north, and bear back the equatorial current, and envelop the entire island with a wall of ice.

These rapid changes of direction of currents, with accompanying marked alteration of climate, appear to bear a close analogy to those which must have obtained in South Britain when the alternating beds of boulder-clay and sands and gravels were being deposited, clay with scratched stones during the colder intervals, and sands during the warmer episodes, when the waves were fretting coasts unprotected by ice.

Icebergs appear to have ground the surface of the rudely columnar trap-rocks of the Thousand Islands, which are covered with countless smoothed and rounded boulders of the local trap, and of red granite derived from the centre of Spitzbergen, forty miles distant.

In one of the cluster of islands off the coast at Black Point is a channel 100 yards long, three or four feet wide, and four deep, running N.E. and S.W., excavated in the boulders, which Mr. Lamont believes to have been produced by the passage of an iceberg, when the land stood lower than at present. The power of bergs to groove and scoop out hollows has been denied, and it is to be hoped that the

officers of the Arctic Expedition will have opportunities of ascertaining what the usual character of the bottom portion of a berg is, how far it is capable of grooving rocks and excavating hollows in soft sea beds, with or without coming to rest.

Separated from the great glacier of Deeva Bay by two miles of sea covered with fast ice, is a terminal moraine of mud,  $3\frac{1}{2}$  miles long, 200 to 400 yards broad, and 20 to 30 feet high, on the top of which grow Arctic plants. Observations as to what extent glaciers can extend into the sea, and push moraines before them without breaking off into bergs, would have great interest, for in this instance the sea must have been deeper during the maximum size of the glacier than now, as bones of whales occur at heights of more than forty feet above the present sea level.

One of the three large glaciers that protrude into the sea between Black Point and Ryk-Yse Islands has a sea front of thirty miles, sweeping in three great arcs, five miles beyond the coast line, terminating in a precipitous wall from 20 to 100 feet in height, from which bergs are constantly tumbling into the sea, carrying stone and large quantities of clay and stones seawards. The position of the melting area of such bergs as these, and consequent deposition of erratic material, is a point of great interest in attempting to unravel the British glacial phenomena.

Prof. Wyville Thomson, dredging on the edge of the southern ice pack, brought up fine sand and greyish mud, with small pebbles of quartz, felspar, and small fragments of mica-slate, gneiss, and granite, derived from the melting of icebergs found in lat. 65° or 64° S., which represents their melting area, while further south in 200 to 250 fathoms of water, in which they first commence to float, land debris is much rarer; at the surface of the water in the melting area, *Globigerina* and diatoms are numerous, but do not form a deposit at the bottom, owing to the deposition of silt obliterating them.

*Recent Elevation of Spitzbergen.*—From the observations of Mr. Lamont it may be inferred that during the past 400 years Spitzbergen has been rising at the rate of thirteen feet per century.

*Bear Island* (lat. 74° 30' N.)—From the plants and specimens collected by Professors Nordenskjöld and Malmgren, the following classification of the rocks of the island has been established\*:—

MILLSTONE GRIT.—Siliceous schists.

MOUNTAIN LIMESTONE STAGE.—*Proauctus* limestone, *spirifer* limestone with gypsum, resting on *Cyathophyllum*-bearing limestone and dolerite, possibly the equivalent of the Carboniferous shale with *Cyathophyllum* of the south of Ireland.

URSA STAGE OF O. Heer.—Sandstones, with shale and coal-seams. All the beds contain plants.

DEVONIAN.—Russian Island limestone, red shale.

The Russian Island limestone, which spreads over so large an area in Spitzbergen, contains no determinable fossils, and, like the shales beneath it, is of doubtful geological age, probably, as suggested by Nordenskjöld, belonging to the Devonian. No true coal measures are present either in Spitzbergen or Bear Island.

The "Ursa Stage" Prof. Heer correlates with the Kiltorkan beds in Ireland, the Greywacke of the Vosges and southern Black Forest, and the *Spirifera Verneuilii* shales of Aix, and the sandstones of Parry and Melville Islands in the Arctic Archipelago; and from the marked absence of Devonian and coal-measures species, regards the stage as of Lower Carboniferous age, the base of which he considered to be beneath the yellow sandstones; but Sir Charles Lyell, from the fact that these sandstones at Dura Den, in Fife, and in the co. Cork, contain the exclusively Devonian fish *Asterolepis* and *Glyptolepis*, believed these deposits to be Devonian, which

\* Continued from p. 494.

† In the following notes on Spitzbergen and other neighbouring islands, only those points have been touched on as have a direct bearing on the geology of the area already described.

‡ Quar. Jour. Geol. Soc., vol. xxx. p. 455; 1874.

§ "Frost and Fire," by J. F. Campbell, vol. I. p. 483.

|| "Seasons with the Sea Horses," London, 1866.

¶ "Letters from High Latitudes." (London.)

\* Quar. Journ. Geol. Soc., vol. xxviii. p. 161. (Read Nov. 9, 1868.)

opinion Mr. Carruthers also expressed in reference to the plant both of the Irish and Bear Island deposits.\*

In Eastern America the Lower Carboniferous Coal-measures (Calcareous Sandstone of Scotland) lie unconformably on the Devonian, which contains different fossils; but in Ohio a transition between the Devonian and Carboniferous flora takes place, according to Principal Dawson, at the base of the latter,† and he suggests a similar blending in Bear Island.

Prof. Meek has shown that the rock exposures of the Mackenzie River between Clearwater River and the Arctic Ocean are of Devonian age, and correspond to the Hamilton formation and Genesee slate of the United States. The slates contain brine springs and petroleum, and it is through that they extend in a north westerly direction from Rock Island, Illinois, to the Arctic Sea, a distance of 2,500 geographical miles, the fossils being identical on each end of the tract, proving how little the paleozoic marine life was influenced by climate. From the Mackenzie slates many new corals and brachiopods were obtained, also a cephalopod, *Gyoceras Logani*, collected by the late Mr. R. Kennicott.‡ It is therefore in the highest degree probable that the coal-bearing beds of Parry and Melville Islands belong to a continuation of these beds, and are referable to the "Ursa Stage" of Heer, whether that slate is the top of the Devonian or the bottom of the Carboniferous; and from the fact that not a single species of the Bear Island flora exists in the Upper Devonian Cypris shales of Saalfeld in Thuringia, Prof. Heer believes that the Ursa Stage is Lower Carboniferous. In Bear Island it is characterised by *Calamites radiatus*, *Lepidodendron Veltheimianum*, *Knorria acicularis*, *Stigmaria ficoides*, all of which are found in the Yellow Sandstone of Kiltorkan; and considering the persistence of freshwater genera, it is not remarkable that some genera of fish that occur in Old Red of Scotland still lived on in these Kiltorkan sandstones. Should, however, fish remains be found in the strata lying in synclinal hollows of the Silurian rocks of the Arctic regions, their specific determination and that of the associated forms, may be expected to throw much light on the vexed question of the line of demarcation between Devonian and Carboniferous. The presence of *Knorria acicularis* in the Melville Island flora is a link between the flora of the South of Ireland and that of Bear Island; the latter is undoubtedly an outlier of the Russian Lower Carboniferous coal tract. Looking to the number of species in this flora, which can be traced in the northern hemisphere, both in the Old and New World, from 47° to 74° and 76° north lat., and to the fact that it is the first rich land flora in the earth's history, there is evidence that a widespread continent occupied much of the Arctic as well as of the temperate zone, over which ran large rivers tenanted by the freshwater mussel (*Anodonta*) and Neuropterous insects.

The subsidence which brought in the deposition of the Mountain Limestone and the existence of extensive coral reefs equally affected the Arctic zones, and these formations occur both in Spitzbergen and Bear Island, as in the islands of the Arctic Archipelago. Equally also is the return of continental conditions expressed by the European Millstone Grit, represented in the Arctic zone by the siliceous schists of Bear Island. During this period many plants of the Ursa Stage still lived in Europe, proving that islands covered with the old flora existed throughout the whole era occupied by the deposition of the Mountain Limestone. And it is worthy of note, as Prof. Heer has pointed out, that the leaves of the evergreen tree *Lepidodendra*, and the large fronds of *Cardiopteris frondosa*, are as fully developed as those from the South of Ireland and the Vosges; and it is clear that the climate of these Arctic regions must have been far warmer than

at present, even if the darkness of the long winter nights were the same as now.\*

*Spitzbergen*.—In the Klaas Billen Bay of the Eis Fjord, Wilander and Nathorst discovered the Ursa Stage in 1870; overlying it are the Miocene beds which have yielded so rich a flora and fauna to various expeditions which have visited the island. In the black shales of Cape Staratschin, *Sequoia Nordenskjöldi* and *Taxodium distichum* are the most characteristic trees. At King's Bay, a Lime (*Tilia Malinquenti*), a Juniper, an *Arboryta* (*Thuiles Ehrenswaerti*)—many of the species occur in West Greenland—and two, *Taxodium distichum* and *Populus arctica*, were found by Lieut. Payer, of the German Exhibition, in the fossiliferous marls of the Germania Mountains, in Sabine Island, East Greenland, also. At the present time, firs and poplars grow in an area 15° further north than plane-trees; so that, assuming the former to have reached their northern limit in Spitzbergen in lat. 79°, the oaks must have grown, provided there was land, as far north as the pole.†

The so-called wood-hills discovered in 1806 by Sirowatskoi on the south coast of the island of New Siberia, stated by Wrangel ‡ to consist, according to Hedenström, of horizontal beds of sandstone, alternating with vertical bituminous trunks of trees, forming a hill 180 feet in height, are no doubt part of the great Miocene deposit which stretches from Vancouver's Island through Northern Asia into Europe. The evidence of the former continuity of land is borne out by the presence in Greenland of species of the Japanese genus *Glyptostrobus* and *Thujopsis*, which last, *T. europæa*, occurs in Europe, in Amber and at Armissan (Narbone); associated with it are American forms, which, as pointed out by Prof. Göppert (Geol. Trans. 1845), chiefly characterise the flora associated with the Amber pines of the south-eastern part of what is now the Baltic.

An examination of the fauna and flora of the Miocene rocks of Europe and Asia indicates a continental period of long duration, which experienced at its commencement a tropical climate, gradually becoming more temperate as time elapsed.

In the Upper Miocene beds of Eningen, North American types still live, and are more numerous than in the later Italian Pliocene flora: amongst them is a vine, four palms of the American type, *Sabal*, planes of American type, and conifers *Sequoia* and *Taxodium*. The palms, whether of the European or American type (*Chamærops* and *Sabal*), and other exotic forms, are found to be absent in the Miocenes of the northern area, proving that the climate became cooler in advancing northwards, as at the present time; for through the enormous expanse of continental land the climate was much more equable than at present. There is therefore no reason to believe, from the absence of these plants, and of bones of long-armed apes present in the Miocene of Central Europe, that the Lower Miocene is absent in the Arctic zone; and from the determination by Prof. Heer, of Cretaceous forms in the Greenland deposits, it is probable that the continental conditions expressed by the Miocene of Europe and India had commenced in these polar regions as early as Cretaceous times. Should further discoveries of freshwater Cretaceous and Miocene deposits lying in the hollows of the older rocks be found in the northern lands visited by the British Arctic Expedition, it will be of great interest to see how far southern species die out in advancing to the present pole, and what minimum of cold the surviving species appear to indicate.

C. E. DE RANCE

\* Prof. Ramsay has directed my attention to Mr. Croll's recent work, "Climate and Time," in which the occurrence of Carboniferous and Miocene species in the Arctic zone is adduced as evidence of "warm interglacial periods" in these regions.

† Heer: "Miocene baltische Flora;" "Fossil Flora von Alaska," 1869; "Flora Fossilis Arctica," vols. I.-III.; "Ueber die Fossil Flora der Polarländer." Zurich; Fr. Schultze's, 1869.

‡ "Reise längs der Nordküste von Sibirien in den Jahren," 1820-24, th. I. s. 702.

\* Geol. Mag., vol. vii. p. 286.

† Quar. Jour. Geol. Soc., vol. xxix. p. 245.

‡ Trans. Chicago Acad. of Science, vol. I. (Chicago, 1868.)

THE PROGRESS OF THE TELEGRAPH \*  
IV.

IT will only be necessary to describe generally the construction of the Syphon or Recording Galvanometer. It consists essentially of two parts; first, that portion of the machine which, being influenced by the received current, oscillates or moves, thus becoming the motor or mechanical power; and, second, the arrangement for permanently recording or registering this motion. The motor or mechanical power is obtained by the employment of a very light suspended coil consisting of a small number of turns of fine insulated wire, placed in a very powerful magnetic field produced by permanent magnets or electro-magnets; these act with great exciting force upon the suspended insulated wire coil, causing it to deflect or vibrate when the current passes through it.

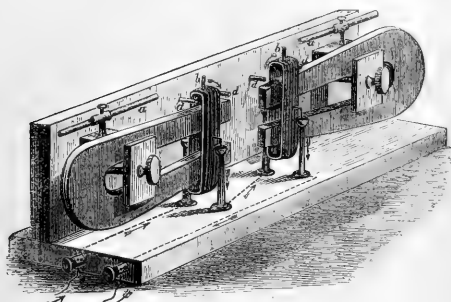

FIG. 18.—Mr. William Sykes Ward's Telegraph, September 1847.

This deflection of a vibratory coil through which a current is passed, over the poles of a magnet, was the subject matter of a patent in 1847, by Mr. William Sykes Ward, of Leeds, in which it is stated, "Signals are indicated by the deflection of electro-dynamic coils, free to vibrate over the poles of a permanent magnet;" the deflection of the coil to right or left indicating either the dot or dash of the Morse alphabet, or the beats of the old double-needle instrument.

This apparatus is represented in Fig. 18. Two permanent magnets are attached to a suitable frame, over the poles of which the oscillating coils are placed, the lateral motions of which, to the right or left, according to the direction of the current, are regulated by the stop pins *d d*.

In connection with each permanent magnet an adjustable permanent magnetic bar *a* is placed, which, acting upon a soft iron exponent *b* attached to the upper extremity of the oscillating coils, regulates the sensitiveness of their movement to the required degree, according as the magnetic bar *a* is advanced or withdrawn from proximity to the soft iron medium *b*. The completion of the circuit through the coils is indicated by the arrows and metallic contacts in the illustration.

In the Syphon Recording Apparatus, to produce the maximum amount of deflection of the coil with the minimum amount of current force, this delicate recording helix is suspended so as to vibrate over a soft iron core placed between the two poles of a powerful electro-magnet, so that the most delicate current traversing the coil receives the maximum amount of magnetic sympathy; the space between the iron core and the poles of the magnet being as narrow as is consistent with freedom of oscillation of the coil.

In tracing the history of the various step-by-step develop-

ments of the telegraph, which will be done subsequently, we shall show that a very beautiful scientific application of electrical statics, obsolete as regards practical results, was developed by Henry Highton in 1846, where the voltaic current was passed through a narrow strip of gold leaf enclosed in a glass tube and placed in a vertical direction before the poles of a powerful magnet. In this arrangement similar results were obtained to that of the oscillating coil over the poles of the magnet, the gold leaf filament being deflected in a curve to the right or the left, according as the current is passed in the one or other direction from the voltaic battery through the gold leaf strip.

Having thus briefly described the *motor*, the second part or recording mechanism of the apparatus comes under notice. The function of this is to impart the motion of the receiving coil to a light capillary tube or syphon of glass, suspended and adjusted to the coil by means of the torsional elasticity of a helical wire. The long leg of this syphon acts as the marker; the short end dips into a reservoir of ink or other marking fluid which is continuously caused to be spurting or ejected from the end of the syphon, by means of electric agency, on to a moving ribbon of paper mechanically drawn over a metal plate electrified in an opposite direction to that of the syphon. Thus a powerful difference of potential or electrical equilibrium is constantly maintained between the tube and the metal plate, the tendency to produce equilibrium resulting in a succession of sparks between the syphon and the metal plate, producing a fine stream of ink or a succession of minute dots on to the surface of the moving paper ribbon. A very fine hair-pencil may be attached to the syphon as a capillary marker, and so dispense with the electrical arrangement. If the syphon remains in a neutral position, a continuous line will be drawn over the paper, but when by reason of the motion of the receiving coil the syphon is drawn either to the right or left, a corresponding deviation from the straight line will be indicated; thus a record is maintained on paper of the movements of the coil, without that movement being in the least degree impeded by friction or any other mechanical defects. To develop fully the effective results of this most delicate recording apparatus, it is evident that some means must be employed more accurate than the human hand for the transmission of the several electric groups and sequences of currents passing through the wire which severally and collectively compose the message. From facts that have been already stated regarding the rapid transmission of electric currents through extended submarine cable circuits, it will be remembered that with a view to obtain a maximum amount of speed, the electric throbs transmitted by the cable should be of equal duration and at equal intervals of time, so as to allow mechanically for the regular difference of tension in the current at the distant end, as well as for the charge and discharge of the circuit. An automatic transmitter for passing the several currents and groups of currents into the circuit is therefore employed. The details of construction of this essential piece of mechanism will be given in the following description of Sir Charles Wheatstone's automatic high-speed printing instrument. It is only natural to suppose that there are several automatic transmitters scheduled in the Patent Office: the reader does not, however, require to become a dictionary upon patent lore or mechanical variations of electrical apparatus, but simply to acquire a general knowledge of the progress of the telegraph up to the year 1875.

In years long since passed, the invention and introduction of the Jacquard Loom produced a vast revolution in the processes of weaving; by its means an automatic record of the groups and sequence of the threads necessary to produce the pattern by being raised to the surface of the cloth was maintained, and a simple mechanical arrangement performed simultaneously with the succes-

\* Continued from p. 472.

sive to-and-fro motion of the shuttle, superseded the laborious and complicated hand process previously in vogue. An endless band of cards is passed successively over the register of the loom, and brought forward at each throw of the shuttle, each card being perforated with holes to represent that integral portion of the pattern, and each hole controlling the elevation of one or more threads in the warp. A series of weighted needles are, as the holes pass, momentarily allowed to drop, and in so doing by a mechanical adjustment raise the respective threads or groups of threads to the surface of the cloth, so that the shuttle passes underneath, and thus the pattern thrown on the surface is automatically repeated as the cards in succession pass over the register. It is this Jacquard loom principle that Wheatstone has employed to weave his electric currents into the line and produce the electric pattern upon his paper at the distant end. The Jacquard loom weaves rapidly, because the mechanical labour incident to the preparation of the pattern is carried out before it is placed on the loom. So with the automatic printer, or electrical Jacquard, the transmitting speed is rapid. The cards used in the electrical loom to regulate the sequence of the currents and groups of signals are prepared before being passed through the instrument, so that the time occupied in transmitting any number of currents and groups of currents to represent letters and words is reduced to a minimum. In electrical transmissions this is important, the cost of manual labour per minute or hour being inappreciable as compared to the value of a minute or two in the occupation of an extended telegraph wire, erected at a cost of thousands of pounds. For instance, a line of poles and a single wire between London and Glasgow would require at least 12,000*l.* for its erection. To obtain the greatest amount of work out of such a wire in a given time is one of the problems of mechanical telegraphy, and commercial success depends greatly upon the speed at which currents of electricity can be sent through a wire of given length. This speed is regulated by the rapidity with which the currents can be transmitted through the

wire without coalescing, that is, without interfering with each other and running together to form a continuous mark at the distant end. Reference has already been made to the conditions to be observed in the passing of currents into metallic conductors to ensure the maximum of speed, that they should be passed into the wire at equal intervals of time and of equal duration. Now, this is what the electrical Jacquard of Wheatstone so beautifully carries out, and the mode by which this electric pattern is woven will now be explained.

The apparatus consists essentially of three distinct parts—one for the preparation of the electrical loom card

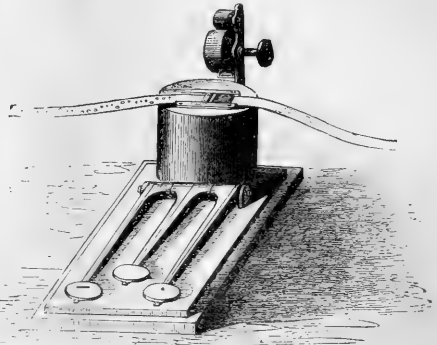

FIG. 19.—The "Perforator," for cutting out the message on the paper ribbon.

to regulate the succession and sequence of the currents in the electrical writing; another, the loom for the passing the currents so grouped into the line; and the third, the shuttle or pattern-producing arrangement by which the currents so passed into the line are recorded and transformed into symbols representing letters, words, and sentences. All automatic high-speed instruments for either submarine or land-wire circuits embody these essential conditions, the mechanical modification of parts

P R O G R E S S O F



T H E T E L E G R A P H



FIG. 20.—Perforated message on paper ribbon.

alone regulating the character of the apparatus for the work to be performed. The message to be sent is first punched out in holes (arranged to represent the "dot" and "dash" of the Morse alphabet) on a continuous paper ribbon by means of an instrument called the "Perforator," shown at Fig. 19, in an elementary form. Each of the three finger-keys on depression perforates a small round hole in the paper ribbon, the right being representative of the dot, the left of the dash, the centre one the mechanical spacing of the holes, and necessary for

the regular motion of the ribbon through the loom or "transmitter."

This perforating machine is so constructed that upon the depression of any one of the keys a threefold action takes place: namely, the paper ribbon in the machine is locked in position to receive the perforation; secondly, the hole is cut by the pressure on the paper of a steel pin; thirdly, a mechanical movement, which at first holds the paper in the direction in which the ribbon enters, after the hole is cut automatically, carries it forward the requisite dis-



tance to receive the next hole ; and thus, by successive depression of the respective punches, the holes are cut in the paper ribbon in the necessary sequences to represent letters and groups of letters to form words. The centre punch, besides mechanically spacing the perforations to ensure their proper passing through the "transmitter," also by individual pressure spaces the distance between the letters and words of the message. The appearance of the paper ribbon thus prepared is shown full size at Fig. 20. Thus the message is written away from the wire, and the time taken up in its preparation is independent of loss of revenue on capital incident to the unnecessary occupation of the circuit by the slow and protracted results of manual labour.

The second part, or "transmitter" of the automatic system, is the apparatus which automatically sends into the wire the sequence of currents, as prepared by the "perforator." In this process, performed much in the same manner as the perforated Jacquard card regulates the successive elevation or depression of the warp-threads in the loom, the perforated ribbon-paper strip is caused to advance step by step through the machine by the successive grip of an oscillating cradle, regulated to advance the paper a distance exactly corresponding to the spacing of the holes by the "perforator," so that by the action of

a rising pin, elevated and depressed alternately at each to-and-fro motion of the rocking frame, the message ribbon is automatically and mechanically impelled forward. Two other spring contact pins, representing respectively the contact with the positive (copper) or negative (zinc) currents of the battery (which may be either magneto- or voltaic-currents of electricity), are actuated by the same mechanical movement, by means of eccentric cam arrangements. Thus, when the perforated paper ribbon is carried automatically forward step by step in rapid succession by the action of the central pin, if a "current-passing" perforation is in position at the moment of passing the paper ribbon with either pin, the respective pin will rise through the hole and make a metallic contact with the battery through the instrument, sending a current into the line in the one or other direction, according to the position of the perforation and the rising of the respective pin. If no perforation in the paper ribbon is in position at the time of the automatic elevation of the respective pins, they fall back by the compensating influence of adjusting springs, and a *mute* movement is made by which no current from the battery is passed into the circuit. It will thus be understood that the action of the transmitter is also threefold as regards the passing of the current and the motion of the paper.

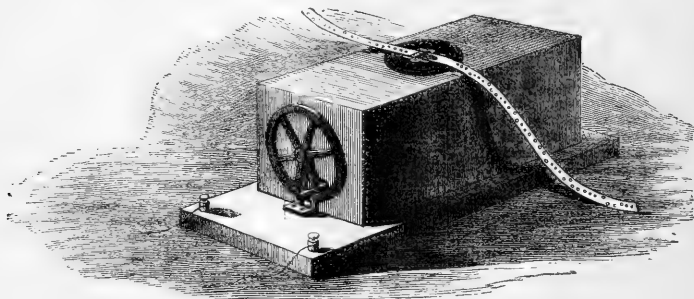

FIG. 21.—Wheatstone's Automatic Tel. graph. The "Transmitter."

First, each rocking of the cradle carries the paper ribbon forward the exact distance that the depression of the key in the "perforating" machine advanced the message slip. Secondly, when the paper ribbon has been thus advanced, it is momentarily held in suspense to admit of the entrance of the respective pin, completing battery contact according to the position of the hole ; and thirdly, if no perforation representative of the passing of a current into the line is in position, a mute movement of the pin is made, and the paper is simply automatically advanced forward by a regular step by step movement. In addition to these three mechanical cam and eccentric movements in connection with the advancement of the ribbon, the elevation of the pins, and the passing of a current into the circuit from the concurrence of a perforation in the paper ribbon and the rising of a pin, a fourth important electrical contact movement takes place at each successive motion of the rocking cradle, independent of the rising of the pins, namely, that of momentarily making contact between the line wire and the earth after each successive elevation of either current-passing pin. The importance of this discharge to earth to clear the line has previously been pointed out as arising from the sensible retention in the insulated wire of a portion of the transmitted current, which, unless drawn cut, would interfere with the integrity of the succeeding current, reducing the transmitting speed of the wire.

By a very beautiful arrangement of electrical contacts (perfected by Mr. A. Stroh, to whose great skill as applied to electrical problems of a mechanical nature Wheatstone is indebted for the absolute perfection of the mechanism in his automatic telegraph—the A B C telegraph—and the sympathetic electric clock movements), after each successive elevation of the pins, the circuit wire is connected momentarily to earth ; this takes place at each motion of the rocking cradle, whether a pin enters a perforation in the paper ribbon or not. Thus the line is connected for discharge at regular intervals, irrespective of its charge by the elevation of a pin, a current only passing into the line by the contact made with the battery on the elevation of either pin.

In this mechanical arrangement, therefore, the necessary contacts with the battery and the regular discharge of the line are produced without recourse to manual labour ; mistakes are avoided, for machinery never forgets its registers or makes false records, both of which errors are inseparable from the employment of the human hand and brain. Man, though a thinking being, is not a machine, and it is not possible ever to turn the human frame into an automaton ; were this so, the value of invention would be at an end, and the accurate performance of machinery at a discount.

(To be continued.)

## THE "ZENITH" BALLOON ASCENT

ON Monday, M. Gaston Tissandier read a paper before the Paris Academy of Sciences on the recent fatal balloon ascent, in which he expressed his deliberate intention of renewing the attempt. The real cause of the catastrophe was the throwing out of ballast at an immense height; Tissandier attributes it to the "vertigo of high regions." The pain felt is so small that one forgets the danger in wishing to reach a higher level; so that he who is not able to restrain himself is not fitted to be an aeronaut in high regions.

The carbonic acid tubes having been broken in the fall, no analysis could be made, and consequently it is necessary to make another ascent in order to complete the experiment.

The figures given by M. Tissandier in his paper are substantially the same as those given in last week's NATURE (p. 495). The height reached was 8,600 meters, as proved by maximum-barometers, which had been sealed up, and were opened in the laboratory of the Sorbonne.

I believe the rapidity of ascent, but mainly the gas which escaped from the balloon, were instrumental in the deaths of Sivel and Crocé-Spinelli.

The matter deserves to be carefully investigated, and I shall try to elucidate it by an ascent which I propose to make next Sunday from La Villette, with Durouf and the *Times* correspondent. Our intention is not to make a race for a high altitude, and we will do our best to resist the vertigo of high regions so vividly described by Tissandier in his paper.

W. DE FONVIELLE

is, however, found in Japan; and the Barbary Ape (*M. inuus*) from Ape's Hill has crossed to Gibraltar. The genera *Cercopithecus* and *Cynocephalus* are confined to the Ethiopian region.

The Platyrrhine Monkeys, with an extra pre-molar on each side of each jaw, are inhabitants of the tropical portions of the Neotropical region only. Amongst them are included the genera *Cebus*, *Ateles*, *Myodes*, *Brachyurus*, and others, some with, and others without, prehensile tails, many of which have, at one time or other, lived in the Society's Gardens. The Marmosets have one less molar in each half of each jaw, which makes the number of their teeth the same as in man, although this is the consequence of there being four more pre-molars and four fewer true molars.

The Lemuridae, whether they ought to be included with the monkeys, or whether they form an independent group, may be considered with the quadrumana, as has been usually the case. They are distributed throughout the Ethiopian and Indian regions, nearly all the species, including *Chiromys*, being confined to Madagascar, which must be considered their true headquarters.

The following is an abstract of Mr. J. W. Clark's lecture on Sea Lions, delivered on April 22nd.—The Pinnipedia, comprising the Sea Lion, Sea Bear, Seal, and Walrus, are true mammalian animals, entirely differing from fish both in structure and habit. The Order naturally falls into two subdivisions, namely, the Eared and the Earless Seals; or, the Otariade, otherwise called Sea Lions, and the Trichechide (Walrus), together with the Cystophoride (Bladder-nosed Seals) and Phocide (True Seals). The former of these groups, the Otariade, differ from the Seals, the Phocide, in other respects than the possession of ears. They can use their limbs freely to raise the body from the ground and to walk on the land. They can even run swiftly for a short distance. The Seals, on the contrary, always retain their hind feet stretched out backwards, the legs being so enclosed within the integument of the body that they have little or no independent motion. They consequently are only able to progress on land by a series of ungraceful bumps, wriggling on the stomach. The body of the Sea Lion is peculiarly flexible, whilst that of the Seal has but little motion on its axis, the animal progressing in the water in much the same manner as the Porpoise. The Sea Lion's head is also more elongated and narrow in proportion to its width than that of any Seal. Its ears are small, conical organs, projecting backwards, and so rolled up, scrollwise, that their concavity is rarely shown. But by far the most modified portions of the body of the Sea Lion are the hands and feet. In the Seal the arm is wholly imbedded in the integument, the hand alone projecting. In the Sea Lion, on the contrary, nearly the whole of the upper half of the limb is free, and the thumb is much lengthened, this digit in the Seals being of the same length as the others. In the hinder extremity the lower part of the leg and the foot are free, the rest of the limb being bound up with the body.

With regard to the skin of the Sea Lion; on a superficial view the body appears to be covered with coarse stiff hair, which varies in length on different parts. Old males are said to develop a mane, whence the name given them by early voyagers, but it is not certain that this ornament is present in all the species. Beneath this hair there is a crop of under wool, distributed in delicate, short, fine hairs set at the base of the other larger ones. It appears to exist all over the body.

This part of the subject is rather involved. It is stated that of these Otariade, or Sea Lions, some species have under-fur whilst others have not, and attempts have been made to divide them into families accordingly. It is, however, highly probable that all Otariade have under-fur at some period of their lives. It is this under-fur of the Sea Lions which makes that sealskin in which all ladies delight.

The habits of the Sea Lion are among the most curious in the whole of the animal kingdom. Its food consists mostly of fish, mollusca, crabs, and penguins. The molar teeth being small, it cannot masticate its food, and when it has caught a fish, too large to be swallowed outright, it has been seen to give its head a sudden twist, so as to break off a portion of the fish, which it swallows rapidly. It then dives into the water, picks up the other portion, and repeats the tearing process until the last fragment is decouered.

Their favourite places of resort are solitary islands, either far out at sea, or at any rate clear of an inhabited coast. Many return year after year to the same rock. The natives at the

## LECTURES AT THE ZOOLOGICAL GARDENS

ON Thursday, April 15, the first of the ten lectures announced for the present season was given by Mr. Sclater, F.R.S., "On Monkeys and their Geographical Distribution."

After referring to the considerable series of monkeys in the Society's collection, from which a specimen of the Chimpanzee (*Troglodytes niger*), of an albino Macaque Monkey (*Macacus cynomolgus*), and others were exhibited, Mr. Sclater drew attention to the six zoological provinces into which the surface of the earth was generally acknowledged to be divided. These he had named and defined as follows:—

1. *Palaearctic Region*.—Europe, Africa north of the Atlas, and North Asia.
2. *Ethiopian Region*.—Africa south of the Atlas, and Madagascar.
3. *Indian Region*.—South Asia, Philippines, and Islands of Indian Archipelago to Wallace's Line.
4. *Arctic Region*.—North America down to Isthmus of Tehuantepec.
5. *Neotropical Region*.—Central America, south of the Isthmus of Tehuantepec, and South America.
6. *Australasian Region*.—Australia, New Guinea, and Austro-Malay Archipelago. No monkeys being found in the Austral or Nearctic regions, and none in the Palaearctic, except the Macaque of North Africa and Gibraltar.

Commencing with the Anthropoid Apes, the Gorilla (*Troglodytes gorilla*) was shown to inhabit the tropical regions of West Africa only, not extending south beyond the River Gaboon. The same region is the home of the Chimpanzee, which, however, spreads to the east for a considerable distance, having been captured in Abyssinia. It is also found as far south as the north bank of the River Congo. Of the two other genera of Anthropoid Apes, the Orang Utan and the Gibbon, the former is confined to Borneo and Sumatra, the latter to the Malay Peninsula, Assam, and the islands of the Indo-Malay Archipelago.

Of the Catarrhine or Old World Monkeys, there is a peculiar long-tailed genus, *Semnopithecus*, found in India and the Malay region. This is represented in Africa by the similarly peculiar genus *Colobus*, which wants the thumb; it is found mostly in West Africa, extending east as far as Abyssinia. Of this group the Indian Entellus Monkey is best known. The genus *Macacus* is almost confined to the Indian region; a species (*M. speciosus*)

Pribilof Islands\* affirm that one old male seal, recognised by the loss of one of his flippers, returned seventeen years in succession. The ground they occupy, called a "rookery," is the space between the high-water line and the foot of the cliffs. The sandy beach forms the play-ground for the pups, the uplands being their sleeping places. Like the bees, they are

"Creatures that, by rule in nature, teach  
The art of order to a peopled kingdom."

The arrangement of their dominions are adopted by common consent, and enforced by the elders with much severity. The old males and the full-grown females are alone allowed upon the rookeries; the young seals swim about during the day, at night retiring to the uplands. The natives of the Pribilof Islands called the old males "Married Seals," the old females "Mothers," and the young females "Bachelors."

During the winter months the rookeries of the Pribilof Islands are entirely deserted, except by a few stragglers; but Capt. Musgrave, who was wrecked on the Auckland Islands, south of New Zealand, tells us that there numbers remain all the year round. In the spring a few old veteran males—the chiefs of the herd—make their appearance near the islands, swimming about for several days. If all is safe, they land and examine the rookery; they depart for a few days, and return accompanied by a number of other veteran males. These land, each taking up a position, reserving for himself a space of about thirty square yards, which he defends against all comers. About two months later the females begin to make their appearance. It is the duty of the "Bachelors" to drive them on to the rocks, the nearest adult male going down to meet each female, coaxing her until he can get between her and the shore. His manner then immediately changes, and with an angry growl he drives her up to his resting-place. It seems to be the object of each of these polygamous sultans to attach to himself a harem of from fifteen to twenty wives. When the males nearest the water have made their choice, those in the next row higher up watch for an opportunity to steal the wives of their more fortunate neighbours. When all the females have landed and been distributed among the claimants, no further change takes place, each sultan walking round and round his family and driving off all intruders. This is the account given by Capt. Bryant, commander of the station at the Pribilof Islands. Capt. Musgrave, in his account of the Seals of the southern hemisphere, does not indicate that this jealous distribution is so customary.

The cubs are born a few days after the arrival of their mothers, and always on shore. They have a great aversion for the water at first, and are taught to swim by their mothers. It is a most curious fact that during all the while these creatures are on shore they remain absolutely without food; they arrive excessively fat, and, as is not surprising after a fast of two months, depart extremely lean. When the young can shift for themselves the rookeries are broken up.

Respecting the different species of these Sea Lions and their geographical distribution, Magellan, in 1519, was the first to notice their chief peculiarities. He found them on an island south of the River Plate, and called them Sea Wolves. No naturalist, however, distinguished them from the Seals proper, with the exception of the Russian Steller, who, visiting the Aleutian Islands in the middle of the last century, saw the two species which are found there, and described them as the Sea Bear and the Sea Lion. Linnæus, in 1758, nevertheless included them all in his genus *Phoca*, and it was not till 1800 that Péron again separated them. Subsequently, they have been minutely studied by Dr. J. E. Gray, and Dr. Peters of Berlin. Both these authors, however, have been far too fond of making new genera and species upon single skulls, or even single skins. It seems to me better to retain Péron's original genus *Otaria* for the whole group, the number of species of which amount to nine. True Seals inhabit the Arctic and Antarctic seas, as well as the temperate regions in both hemispheres, together with the Antilles and Madeira. The *Otarias* are more tolerant of warmth, and are apparently more susceptible to changes of climate. A remarkable fact about their distribution is that none are found in the Atlantic, except in its extreme south. From the mouth of the River Plate they extend all round the coasts of South America and the adjoining islands. Proceeding north, they are numerous upon the coast of California, and extend round by the Aleutian Islands to the coast of Japan. Their most northern known station is that of the Pribilof Islands; further investigation

\* Situated in Behring Sea.

will perhaps reveal their existence in some of the islands north and south of the equator in the Pacific Ocean. They are found all round the coasts of New Zealand, the Auckland, Tasmania, and Southern Australia. They are said to inhabit Kerguelen's Land and the Crozets; we also know that there is one species at least near Capetown, a specimen from that locality being now alive in the Zoological Gardens.

(To be continued.)

### NOTES

AN appeal is being made by the Committee for the Exploration of the Victoria Cave, Settle, for additional funds; the work, we much regret to say, being actually at a stop from want of means. This is not as it should be, and we feel sure that the state of matters only needs to be made known to the scientific public in order to have it remedied. The importance of these explorations need not be insisted on in these pages; results have been already achieved of the highest value to the geologist, the historian, and the antiquary. What further records may be found at the cave in lower and earlier deposits than those yet investigated, is a question which can only be solved by actual work. The bottom of the cave has never yet been reached. The series of bones obtained during the past year is exceedingly fine, and may challenge comparison with any in the kingdom; and altogether the work, besides bearing already many important results, is one of great promise. The British Association have given three several grants of 50*l.*, but by far the greater share of the expense has fallen on a few individuals who have contributed liberally. This should be so no longer, and we earnestly hope that all our readers will do what they can to help forward an undertaking of so great importance. Subscriptions should be forwarded to John Birkbeck, jun., hon. treasurer of the "Settle Caves Exploration Fund," the Craven Bank, Settle, Yorkshire.

A TELEGRAM dated Bombay, April 22, states that the members of the Solar Eclipse Expedition have left that place on their return to England.

NEWS is to hand of a recent volcanic eruption in Iceland; the following particulars we gather from the Icelandic correspondent of the *Scotsman*:—Shortly before Christmas 1874 earthquakes were experienced over the north-east part of Iceland. About Christmas, columns of smoke were seen rising, and therefore a party were sent from the Myvatn on the 15th of January to reconnoitre. They went straight southwards over Odadabrunn, and made for the Dyngjufjoll. The Dyngjufjoll form a circle of mountains, and within this circle there is a lava stretch called Askja (The Box). Here the exploring party found the eruption to have taken place, and they state that a large crater has been formed, from which lava and clay are being thrown hundreds of feet upwards. They found many small craters grouped round the big one, and from several of these water was flowing. All around the earth was rent into large fissures, and at some places it had subsided to a considerable extent. Since this visit, the column of smoke has been seen daily in clear weather, and slight earthquakes have been felt at intervals. On the night of the 18th February, the gleam of a great fire was seen from Grimstodum, in a western direction. A new exploring party found the fire to be twenty miles from the inhabited district, to the west of the so-called Sveinagia, in the Austurfjollum. The eruption had taken place from several craters. Some have piled up the lava around them into shapes resembling castles; from others the lava had flowed in a stream, and formed a lava-field of large extent. Most of the craters were smoking when the party arrived. The lava stream from all the craters is between two and three miles long, and from 600 to 800 yards broad. At many places the glowing fire was seen on looking down through the fissures, and the crust was found to be two or three feet thick. In two or three places small hollow

cones had been formed, capable of containing two or three barrels inside. Explosions occurred at intervals in the crater, and lava, earth, and stones were thrown up to a height computed at 160 yards. The distance from Myvatn to the craters is calculated to be from forty to fifty English miles.

IN connection with the above, it is interesting to note that reports from Sweden and Norway state that during the night of March 29-30 last, a heavy rain of ashes or sand took place from the west coast of Norway to the Swedish frontier; the whole of the country was covered with grey dust to such an extent that from a pint of snow more than a tablespoonful of residue was left after the snow had melted. Some chemists of Christiania have examined the ashes, and one of them, Prof. Waage, states that the dust consists of little, irregular, but sharp-edged grains, almost all colourless—some few are of brown colour—and they consist principally of silicates. Acids extract some lime, iron, and alumina from their powder. The professor thinks it likely that the dust originates from an eruption in Iceland. This view is confirmed by a mineralogical investigation made on another sample of the dust at the Christiania University, by Profs. Kjerulf and Fearnley; they recognised the dust to consist of fragments of pumice-stone which is identical with the Hecla pumice-stone. According to Swedish newspapers, some traces of the dust-fall were observed even in the vicinity of Stockholm. Prof. Kjerulf also thinks it highly probable that an eruption took place in Iceland. The distance from the Iceland volcanoes to the Swedish frontier is about the same as that from Mount Etna to the Baltic.

THE following information regarding an eruption of the volcano of Ternate (Moluccas) we have received from Dr. A. B. Meyer:—Mr. van Musschenbroek, Resident of Ternate, having made an ascent to the volcano, writes under date Feb. 5: "About fifty small new craters, or rather deep wells, have appeared along the walls of the large crater, and independent of the proper cone of eruption; they are all deep (but it is difficult to say how deep), and about twenty feet in diameter. On some spots, the 'Alang-alang' green was turned upside down. These new, small craters were surrounded by still smaller ones, and by stones thrown out from the interior. This happened at the same time as a rather heavy eruption of the volcano Roelang, near Tagoelanda." Tagoelanda, Dr. Meyer states, is an island in the north of Celebes. He witnessed part of a heavy eruption of the Roelang in 1871 (see NATURE, vol. iv. p. 286). This coincident action of the volcanoes of Ternate and Roelang in January 1875 is interesting, because the same coincidence happened in 1871. Then the eruption of the Roelang was felt in the form of earthquakes and thundrous sounds in the earth, as far as Gorontalo in Celebes to the south, and as far as Ternate (Moluccas) to the east. At a former eruption of the Roelang, in August 1870, the ashes are said to have been thrown to the north as far as Mindanao (Philippine Islands), about 200 miles distant. The Roelang, therefore, appears to be still now a formidable centre of volcanic action.

DURING the present term at Oxford, Prof. Lawson and Prof. Ray Lankester are conducting a class from 10 till 4 o'clock each day, which presents features of special interest on account of its novelty. The course is one of general biological instruction, devised so as to give a survey of the leading features of plants and animals. The practical work is preceded by a lecture. Great pains has been taken to get the types required, some being very difficult to procure, and quite novel as educational specimens. Among these may be included *Æthalion*, *Gonium*, *Cordylophora*, and *Amphioxus*. We hope that Profs. Lawson and Lankester will find that their enterprising attempt to raise the standard of biological study will be sufficiently appreciated to lead them to continue the course on the next seasonable opportunity.

THE Cambridge Museum and Lecture-rooms Syndicate have issued their Ninth Annual Report. They draw attention to the insufficient accommodation for examination purposes and the insufficiency of space for the students in comparative anatomy. Considerable use has been made during the past year of the Cavendish Laboratory, which is being rapidly fitted at the expense of his Grace the Chancellor, the Duke of Devonshire, with the apparatus required for physical research. The want of proper accommodation for Dr. M. Foster's classes in Physiology is painfully evident, as those rooms are neither sufficiently large nor sufficiently well lighted for class rooms. The donations made to the different collections have been numerous.

IN a Congregation at Oxford University on Tuesday, a statute, the principal effect of which would be that the examinations in the Natural Science Schools would be held only once a year, and that honours might be obtained in different subjects at different times—creating, in fact, independent Schools of Physiology, Chemistry, and Physics—was thrown out, after a sharp debate, by 25 votes to 23.

THE Council of the Senate of Cambridge University propose to offer a grace early this term for the appointment of a syndicate to consider the propriety of establishing a professorship of Mechanism and Engineering.

THE High School at Newcastle-under-Lyne, which will open after the summer, under Mr. Kitchener, is fortunate enough to have already met with a liberal and wise friend in Mr. Mayer. He has founded a 50% exhibition from the school to the Universities, for Science and Mathematics, besides two minor exhibitions for Art.

WE are informed that Mr. A. R. Wallace has in hand a work on the Geographical Distribution of Animals, which will be looked for with great interest.

THE Annual General Meeting of the Iron and Steel Institute will be held in the rooms of the Institution of Civil Engineers, 25, Great George Street, Westminster, S.W., on Wednesday, May 5, and two following days; the president-elect being Mr. William Menelaus. Among the papers to be read are the following:—Notes of a Visit to Mines and Ironworks in the United States; and on the Sum of Heat Utilised in Smelting Cleveland Ironstone, by Mr. I. Lowthian Bell, F.R.S. The Estimation of Small Quantities of Phosphorus in Iron and Steel, by Spectrum Analysis, by Sir John G. N. Alleyne, Bart. The Manufacture of Bessemer Steel in Belgium, by M. J. Deby, Brussels. The Summer Meeting will be held at Manchester early in September.

SIR HENRY RAWLINSON, at Monday's meeting of the Royal Geographical Society, intimated that the Society had awarded the two medals of the year to the two great Arctic explorers, Lieut. Payer and Lieut. Weyprecht. With reference to the prizes the Society offered to the public schools, the following are the awards:—Physical Geography—Gold medal, Henry Alexander Miers (Eton College); bronze medal, Archibald Edward Garrod (Marlborough College). Political Geography—Gold medal, Sydney H. B. Saunders (Dulwich College); bronze medal, W. C. Graham (Eton College).

THE Paris Geographical Society held last week its annual meeting in the great hall of the *Société d'Encouragement*, Rue Bonaparte; more than 3,000 persons were present. The number of members of the Society has largely increased since MM. Thiers and Barthélemy Saint-Hilaire joined it. Preparations are being actively made for the forthcoming International Geographical Meeting, which is to be held at the Tuileries, as we have already intimated, in August next. The offices of the Congress are already opened in the *Pavillon de Flore*, but all

communications should be sent to the Geographical Society, 3, Rue Christine.

AT the meeting of the French Geographical Society last week, a gold medal was presented to Mr. Washburne for the family of the late Capt. Hall, the American Arctic explorer.

IN the University of Edinburgh, Miss Flora Masson has passed the examinations for University certificates in Arts for women, with honours of the first class, in English Literature; and Miss Annette Conan Doyle has passed the ordinary examinations in English Literature, Chemistry, and Mathematics.

M. EUGÈNE GODARD will probably obtain authority to hold an international balloon race in Paris. The proceeds will be given to the families of Sivel and Spinelli.

THE death is announced on Saturday last, at the early age of thirty-seven years, of Mr. Winwood Reade, whose name is no doubt familiar to readers of NATURE as the author of "Savage Africa" and the "African Sketch Book."

THE Norwegian Storting has adopted the Government Bill for the introduction of the metrical system of weights and measures.

M. WURIZ is to remain the Dean of the Paris École de Médecine. The report of his resignation, to which allusion was made in our last number, has been contradicted.

IN a paper on the age of the Tertiary deposits of Malta, published in the third part of the *Sitzungsberichte der Akademie der Wissenschaften in Wien*, Dr. T. Fuchs states that these beds belong to two distinct stages; the older, representing the "Bormidian" of Sismonda (Aquitanian), may be regarded as equivalent to the Oligocene marine Molasse of Switzerland and Bavaria, the strata of Bajas, Merignac, and some less known Central European deposits; the newer as equivalent to the "Leythalkalk" of Vienna (Sarmatian stage). He states, in opposition to previous authors, that these two series of beds have scarcely any fossils in common, and remarks especially that the great Pectens and Echinoderms do not occur in the upper strata. Dr. Fuchs believes that many Syracusan Pliocene fossils have been described as derived from Malta. The two series are conformable in their stratification.

IN a second paper in the same publication, Dr. Fuchs announces the occurrence of Miocene beds, which he also identifies with the "Leythalkalk," unconformably underlying the Pliocene deposits near Syracuse, and forming a great plateau to the west of that city.

THE same journal contains an interesting contribution to the palæontology of the Arctic regions, in the shape of descriptions of fossil shells from the Carboniferous Limestone and Zechstein rocks of Horn Sound, on the south-western coast of Spitzbergen, collected during the recent Austrian expedition to those regions. The author of the paper, Dr. F. Toula, enumerates seventeen species of Brachiopoda, three of which are described as new, and a new Aviculopecten. Most of the fossils are figured.

MR. VAN VOORST has just ready for publication "The Flora of Eastbourne," by Mr. F. C. S. Roper, F.L.S., President of the Eastbourne Natural History Society.

PROF. HELMHOLTZ' work "On the Sensations of Tone, as a Physiological Basis for the Theory of Music," translated (with the author's sanction) from the third German edition, with additional notes and an additional appendix, by Mr. A. J. Ellis, F.R.S., is nearly ready, and will be published in the course of a week. It will be issued by Messrs. Longman and Co.

THE same firm will publish, during next month, "A Short Manual of Heat," for the use of Schools and Science Classes, by the Rev. A. Irving, Second Master of the High School, Nottingham.

THE following information, with regard to the Gresham Lectures, we take from the *Journal of the Society of Arts*:—"It appears that the nomination to vacancies as they occur among the Lecturers, is alternate between those members of the Gresham Committee who are appointed by the Corporation of London, and those appointed by the Mercers' Company. It is understood that the filling up of the present vacancy, occasioned by the resignation of the Rev. Jos. Pullen, the lecturer on astronomy, rests with the Corporation side of the Committee, and that they have determined to commence a reform in the administration of this bequest. They therefore intend to make the appointment annual, dependent on the popularity of the lecturer, to increase the number of English lectures, and to get rid altogether of the useless Latin lecture. It is to be hoped that the Mercers' Company will take up the question in a similar spirit."

THE *Journal of the Society of Arts* contains some details concerning Scientific and Literary Societies in India. The Bengal Asiatic Society was founded by Sir Wm. Jones in 1774, and the Madras Literary Society was formed in 1818. The Bombay branch of the Asiatic Society dates from the year 1804, and in 1817 it was grafted on to the Royal Asiatic Society in England as the Bombay branch. Its Journal was established in 1841, and the publication has been regularly kept up ever since at intervals of one or two years. The Bombay Geographical Society, which dates from 1830, was in 1873 amalgamated with the Bombay branch of the Asiatic Society. The Medical and Physical Society, though it languished from 1863 to 1869, has now been revived, and published a large volume of transactions in 1871. The Sassoon Mechanics' Institute has 346 members, courses of lectures, and a good library of reference of 13,935 books. In Calcutta, besides the venerable Asiatic Society, there are several other societies both for Europeans and natives, and for the latter alone. In Bombay, the Students' Literary and Scientific Society consists exclusively of natives, and has 111 members.

THE additions to the Zoological Society's Gardens during the past week include a Great Kangaroo (*Macropus giganteus*) from New South Wales, presented by Mr. Carleton V. Blyth; a second specimen and a Red Kangaroo (*Macropus rufus*) born in the Gardens; a Persian Gazelle (*Gazella subgutturosa*) from Persia, presented by Mr. C. Czarinkow; two Kinkajous (*Cercoleptes caudivolutus*) from North Venezuela, presented by Mr. Chas. Campbell Downes; a Grey Ichneumon (*Herpastes griseus*) from India, presented by Mr. H. M. Grellier; a Macaque Monkey (*Macacus cynomolgus*), White var., from Samar, Philippines, presented by Mr. J. Ross; a Crowned Eagle (*Spizaetus coronatus*) from Senegal, received in exchange; two Silky Marmosets (*Mlidus rosalia*) from Brazil; an Ocelot (*Felis pardalis*) from South America, purchased.

#### EASTER WEEK AT THE SORBONNE

(Réunion des Dilectés des Sociétés Savantes des Départements.)

THE idea of utilising the Easter vacation as the date, and the venerable Sorbonne as the place, of the annual gathering of the representatives of the learned societies of France was a very happy one, and, like all good ideas, it is crowned by a yearly increasing success. Numbers are but a feeble guide as to the importance of a gathering, yet even in numbers the list of delegates was strong (more than 250); but the true value of the meeting will be better estimated when we have given a brief report of some of the communications read and discussed, in doing which we shall necessarily mention some of the best-known names. We have purposely used the term "some of the communications," because, as the science list alone contains

ninety-one papers, it would obviously exceed our limits if we were to notice them all.

The first general meeting took place on Wednesday, March 31, at noon, under the presidency of M. Leverrier, who, after congratulating the members on the very full attendance, announced the nominations of the various sectional officers which had been made by the Minister of Public Instruction, viz. :—

1. Section for History and Philology.—President, M. Léopold Delisle; Vice-president, M. Lascoux; Secretary, M. Hippéau.

2. Section for Archaeology.—President, M. le Marquis de la Grange; Vice-president, M. Léon Renier; Secretary, M. Chabouillet.

3. Section for Science.—President, M. Leverrier; Vice-president, M. Milne-Edwards; Secretary, M. Emile Blanchard.

After the transaction of some formal business, the meeting was closed. At 2 P.M. the members assembled in the various section-rooms, and the reading of papers commenced.

There were several interesting papers in the Sections of *History and Philology* and *Archæology*, and we regret that want of space prevents us referring to them in detail. We can only mention M. Le Héricher's paper on the "Application to Philology of the Darwinian Theory of 'the Struggle for Life,'" M. Vimout's "Notice of the Archæological Excavations made under the superintendence of the Academy of Clermont-Ferrand on the summit of the Puy-de-Dôme;" and M. Léon de Vesly's, "On Symbolism in Egyptian and Asiatic Decorations."

#### Science.

This section was divided into three sub-sections, as follows :—*Mathematics*; President, M. Dieu; Vice-president, M. Allegret; Secretary, M. Saint-Loup.

*Physics and Chemistry*.—President, M. Isidore Pierre; Vice-president, M. Lissajous; Secretary, M. F. Michel.

*Natural Sciences*.—President, M. de Rouville; Vice-president, Prof. Raulin.

Some of the communications were read only before the sub-sections, others both before the sub-section and the full section at its afternoon meetings; we however shall not distinguish between them, but, as with the other sections, give brief notes of the most important papers.

M. Léon Vidal.—"Photographs in Colours." M. Vidal submitted several albums of specimens of the results of his method, which he stated to be extremely inexpensive. As far as we were able to understand the method adopted, it appeared to be that of repeated colour-printing; if so, it is not easy to imagine how perfect specimens can be produced at the price stated, namely, 3 cents per copy.

M. Doumet-Adanson.—"Remarks on the formation of the Salt Lakes of Tunis." The author holds that the saline matter has been derived from the decomposition of the surrounding mountains, and rejects altogether the hypothesis of a great disturbance having simultaneously produced the Mediterranean and the Sahara.

Dr. de Piétra-Santa.—"Consumption in Algeria." The author stated that the evidence collected by the official inquiries of the Climatological Society of Algiers showed that while in the early stages of phthisis the climate of Algiers was beneficial, it was, on the other hand, fatal if it had reached an advanced stage.

Prof. Pousset.—"Application of the method of least Squares to the Radiants of Meteor-showers." This was illustrated by the discussion of nearly 500 observations for the determination of the radiant for August 1874.

Mr. Marsham Adams exhibited and described his *Cœlometer* and his *Mensurator*.

M. Tarrisan.—"Meteorological Observations on the Pic-du-Midi de Bigorre." The most salient facts in this communication were (1) that the rate of decrease of temperature with elevation is, in the Alps, 1° F. for 338 feet, and in the Pyrenees, 1° for 333 feet; (2) at equal altitudes the mean temperature is 5° higher in the Pyrenees than in the Alps, and the height of the snow line in the two districts is found conformable thereto, it being about 10,000 feet in the former, and 9,000 feet in the latter.

At the request of M. Leverrier, General de Nansouty ascended the tribune, and related his hazardous descent from the summit last December.

The General had resolved upon passing the winter at the observatory with an assistant and a mountaineer, but on December 11 the window of their house was smashed by a block of ice detached from a neighbouring peak by the wind.

They were unable to repair it; the temperature inside soon fell below zero Fahrenheit, and the observatory became uninhabitable. They battled with the storm for three days, but finally resolved on attempting to descend; in this they were successful, but it occupied sixteen hours instead of three, which are usually sufficient.

M. Mayet.—"Note on the Medical Statistics of the Hospitals of Lyons." This paper was rather a description of the method adopted than of the results obtained; M. Mayet, after classifying his data, plots them upon curve paper, and compares them with the principal meteorological elements.

M. Truchot.—"On the disintegration of the rocks of Auvergne considered in connection with the formation of arable land." The title of this paper sufficiently explains its nature, except that the author called special attention to the importance of phosphoric acid for agricultural purposes.

M. Abria gave a demonstration of the law of "Double total reflection in uniaxial crystals."

Prof. de Rouville.—"Geological maps of l'Hérault." The author briefly explained the maps which he exhibited and the geological features of the department, and incidentally pointed out the undesirability for many purposes of scientific maps terminating with political or legal rather than physical boundaries.

M. Sirodot.—"Complete dental system of the Mammoths." The author of this paper had certainly ample data whereupon to base his researches, for the collection which he exhibited completely covered the tables, and must have numbered at least 100, and ranged in size from two little milk teeth less than an inch long to full-sized specimens weighing many pounds.

M. Barthélemy gave a brief account of his researches on the respiration of plants, showing how it was continued even in a single leaf detached from the plant on which it had grown.

Prof. Raulin.—"Distribution of rain in the Alps." The learned author gave a brief extempore summary of the seasonal distribution of rain in the Alps, based upon the records of about 200 stations, of which ninety-three were in the Alps and sixty-nine in Switzerland. He stated that the summer rains of Northern Germany extend to the very summits of the Alps, that the system of autumnal rains prevails on their southern slope, while the system of vernal and autumnal rains extends from the foot of the mountains to the banks of the Po. It is only thence, in the plains of Venetian Lombardy, that the system of summer droughts which prevails over Italy is fully established.—M. Renou asked what length of registers had been used, because he doubted if the periods were long enough to determine accurately the seasonal variation; he doubted if ten years was sufficient. Prof. Raulin said that usually the periods were much longer, and he added that, if the seasonal features were pronounced, three or four years would reveal to which class the station belonged, otherwise ten or even twenty years might be necessary.

Dr. Monoyer.—"New formula for determining the proper focal length of spectacles, and other questions in physiological optics." Perhaps the most important feature of this paper was the reference to, and exhibition of, a standard decimal typographical scale, printed in type of the same character throughout, but so graduated in size as to give a perfectly decimal measure of the power of the eyes. We should strongly urge oculists to obtain copies of this scale and introduce them into this country.

Prof. Rochard gave a most spirited and interesting description of his new "Musical Alphabet," of which, if it proves as successful in other places as it has at Nantes, we shall certainly hear more. The professor claims that it is to music what the nomenclature is to chemistry, and what numerals are to calculation; he showed how it almost annihilated the difficulty of time, lessened that of intonation, and facilitated the reading and writing of music. Speaking of the question of transposition and change of key, he added that he had almost ready a piano of which the pitch could be instantly altered to any extent, even in the middle of the most rapid playing. Prof. Rochard concluded by stating that his pupils at the Association Polytechnique had victoriously solved every difficulty put before them; nay, more, they had attacked problems impossible to be resolved by any other system than the musical alphabet.

Prof. Delage presented a memoir "On the Devonian system of the north of the department of Ille-et-Vilaine and on its relation to the Silurian and Carboniferous systems." He showed, by a series of sections taken in the south of the department, that the order of superposition of the various Silurian beds is that adopted in the geological map of the department.

## SCIENTIFIC SERIALS

Poggendorff's *Annalen der Physik und Chemie*, 1875, No. 1. This number contains the following papers:—On the electric conducting power of solutions of the chlorides of alkalies and alkaline earths, and of nitric acid, by F. Kohlrausch and O. Grotrian.—On the gliding of electric sparks, by K. Antolik. The author published his first paper on this subject at the beginning of last year, and has since then been gaining much new experience on the subject; he had observed long ago that if the two discharge balls of a Holtz electric machine are at a certain small distance from each other, the path of the spark is not in a zig-zag line, but straight, and that the spark is often strongly bent or broken in a certain point, which lies nearer the negative pole. Mr. Antolik's idea was that negative electricity leaves bodies somewhat slower than positive electricity, and that the bending point in the spark was the place where the two electricities united. He successfully tried to obtain an image of the spark by letting it pass over a blackened glass bulb; thus he found that the spark glides in three and often five parallel lines. The paper is very elaborate and highly interesting, the author having varied his experiments in all possible ways.—On a universal meteorograph for solitary observers, by E. H. von Baumhauer. The Dutch Scientific Society of Haarlem offered its gold medal and a purse of 300 florins in January 1872, for a sufficient means to determine temperature, density, and degree of moisture of the atmosphere at a considerable elevation above the surface of the earth, and in a manner which makes self-registration and constant repetition of observations possible. Herr Baumhauer's paper enters into the details of this problem and describes certain instruments which the author devised, and which go far to solve the question at stake, although certain modifications of the Society's demand became necessary, there being a great difference when the term "at a considerable elevation" is applied to a spot which is comparatively easy of access at any time, or when, for instance, it denotes a captive balloon. The author, however, describes instruments which would answer very well in both cases.—Continuation of researches on rod magnetism, by A. L. Holz (see vol. 151, p. 69 of these *Annals*).—On the measuring of angles by means of the eyepiece micrometer in astronomical telescopes, by Dr. Matern.—On the proportion of specific heats under constant pressures and in constant volume, by J. J. Müller.—On some observations of the spectra of gases, by Eugen Goldstein. The author has made a series of experiments which tend to show that Willner's idea as to the independence of the gas spectra from differences in the temperature is an erroneous one. They principally consist in interposing a layer of air into the induction current, which lights up the spectral tubes filled with the rarefied gases, sometimes with a simultaneous insertion of a Leyden jar, and thus forcing the current to produce a spark. Mr. Goldstein then shows that in the whole circle of the current the discharge takes place in the same rhythm, therefore that the current passes the tube filled with the rarefied gas just as momentarily as any other part of the circle; from this he concludes that also in the tube the discharge takes place in form of a spark, that therefore the gas ought to show a line spectrum. Now, as this is not the case, and the gas on the contrary shows a band spectrum, the author thinks this a contradiction of Willner's explanation.—The next paper in the number is by Herr Willner himself, and explains the subject very satisfactorily, as he proves that not one of Herr Goldstein's experiments is contradictory to his theory of the different spectra of gases; is the form of the electric discharge in the tubes containing the gases is the main point in question, and Herr Willner proves this to be in the so-called *altered* form, and not as a spark.—Finally, the number contains a preliminary report by Dr. V. Dvorak, on the velocity of sound travelling in water.

## SOCIETIES AND ACADEMIES

## LONDON

Royal Society, April 8.—"Experiments to ascertain the Cause of Stratification in Electrical Discharges *in vacuo*." By Warren De la Rue, Hugo W. Müller, and William Spottiswoode.

Some results obtained in working with a chloride-of-silver battery of 1,080 cells in connection with vacuum-tubes, appear to be of sufficient interest to induce us to communicate them to the Society in anticipation of the more detailed account

of an investigation which is now being prosecuted, and which it is intended to continue shortly with a battery of 5,000 cells, and possibly with a far greater number.

The battery used up till now consists of 1,080 cells, each being formed of a glass tube 6 inches (15.23 centims.) long and  $\frac{3}{8}$  of an inch (1.9 centim.) internal diameter; these are closed with a vulcanised rubber stopper (cork), perforated eccentrically to permit the insertion of a zinc rod, carefully amalgamated,  $\frac{3}{16}$  (0.48 centim.) of an inch in diameter and 4.5 inches (11.43 centims.) long. The other element consists of a flattened silver wire passing by the side of the cork to the bottom of the tube, and covered, at the upper part above the chloride of silver and until it passes the stopper, with thin sheet of gutta-percha for insulation, and to protect it from the action of the sulphur in the vul-

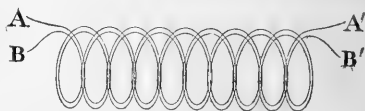

FIG. 1.

canised corks; these wires are  $\frac{1}{16}$  of an inch (0.16 centim.) broad, and 8 inches (20.32 centims.) long. In the bottom of the tube is placed 225.25 grains (14.59 grms.) chloride of silver in powder; this constitutes the electrolyte; above the chloride of silver is poured a solution of common salt containing 25 grammes chloride of sodium to 1 litre (1,752 grains to 1 gallon) of water, to within about 1 inch (2.54 centims.) of the cork. The connection between adjoining cells is made by passing a short piece of indiarubber tube over the zinc rod of one cell, and drawing the silver wire of the next cell through it so as to press against the zinc. The closing of the cells by means of a cork prevents the evaporation of water, and not only avoids this serious inconvenience, but also contributes to the effectiveness of the insulation. The tubes are grouped in twenties in a sort of test-tube rack, having four short ebonite feet, and the whole placed in a cabinet 2 feet 7 inches (78.74 centims.) high, 2 feet 7 inches wide, and 2 feet 7 inches deep; the top being covered with ebonite to facilitate working with the apparatus, which is thus placed on it as an insulated table.

The electromotive force of the battery, as compared with a Daniell's (gravity) battery, was found to be as 1.03 to 1,\* its

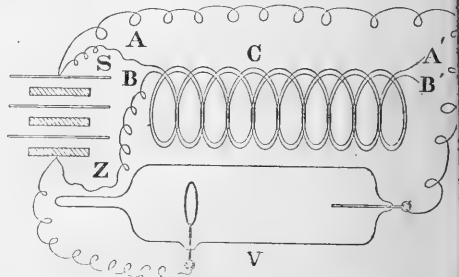

FIG. 2.

internal resistance 70 ohms per cell; and it evolved 0.214 cub. centim. (0.0131 cub. inches) mixed gas per minute when passed through a mixture of 1 volume of sulphuric acid and 8 volumes of water in a voltmeter having a resistance of 11 ohms. The striking-distance of 1,080 elements between copper wire terminals, one turned to a point, the other to a flat surface, in air, is  $\frac{2}{3}$  inch (0.96 millim.) to  $\frac{1}{4}$  inch (0.1 millim.). The greatest distance through which the battery-current would pass continuously *in vacuo* was 12 inches (30.48 centims.) between the terminals in a carbonic acid residual vacuum. This battery has been working since the early part of November 1874, with practically a constant electromotive force.

Besides 2,000 more cells like those just described, we are putting together 2,000 cells, with the chloride of silver in the

\* Compared with a Daniell's battery, in which the zinc is immersed in dilute sulphuric acid in a porous cell, its electromotive force is about 3 per cent. less than the Daniell.



form of rods, which are cast on the flattened silver wires, as in a battery described by De la Rue and Müller,<sup>8</sup> but in other respects similar to the battery above described; the glass tubes being, however, somewhat larger in diameter; the rods of chloride of silver are enclosed in tubes open at the top and bottom, and formed of vegetable parchment, the object of these vegetable parchment cases being to prevent contact between the zinc and chloride-of-silver rods. The internal resistance of batteries so constructed is only from 2 to 3 ohms per cell, according to the distance of the zinc and chloride-of-silver rods, and they evolve from 3 to 4.5 cub. centims. (0.18 to 0.27 cub. inch) per minute, in a voltmeter having a resistance of 11 ohms. Their action is remarkably constant.

For the experiments detailed below, the vacuum-tubes were generally used of about  $1\frac{1}{2}$  to 2 inches (3.8 to 5 centims.) in diameter, and from 6 to 8 inches (15.24 to 20.32 centims.) long; also prolate spheroidal vessels 6 inches by 3 inches (15.24 by 7.62 centims.) The terminals are of various forms, and from 4 inches to 6 inches (10.16 to 15.24 centims.) apart, and made of aluminium and occasionally of magnesium and of palladium; the latter showing some curious phenomena with a hydrogen residual vacuum, which will be described in a future paper. A tube which has given the most striking results is 8 inches (20.32 centims.) long, and has a series of six aluminium rings varying in diameter from  $\frac{3}{8}$  of an inch to about  $1\frac{1}{4}$  of an inch (0.95 to 3.17 centims.), the thickness of the wire being about  $\frac{1}{16}$  (0.16

centim.) of an inch; the rings are a little more than 1 inch (2.54 centims.) apart; and connecting wires of platinum pass through the tube from each ring and permit of the length and other conditions of the discharge being varied.

At times the terminals of the battery were placed in connection with accumulators of different kinds—for instance, two spheres of 18 inches (45.72 centims.) in diameter, presenting each a superficies of 7.07 square feet (65.68 square decims.), and cylinders of paper covered with tinfoil, each having a surface of 16 square feet (148.64 square decims.); the globe and cylinders were in all cases carefully insulated. Other accumulators were composed of coils of two copper wires  $\frac{1}{16}$  of an inch (0.16 centim.) in diameter, covered with gutta percha, in two folds,  $\frac{3}{8}$  of an inch (0.95 centim.) thick. One coil contains two wires, A A' and B B', coiled side by side, each being 174 yards (159 metres) long, another with two wires each 350 yards (320 metres) long; of the latter we have two coils.

In addition to these accumulators we have several others formed of alternate plates of tinfoil and insulating material, such as paper saturated with paraffin, and also sheets of vulcanite. These are of various capacities and contain from 5 to several hundred square feet. The largest has a capacity of 475 microfarads; when it is discharged it gives a very bright short spark, accompanied by a loud snap; the charge deflagrates 8 inches (20.32 centims.) of platinum wire, .005 inch (0.127 millim.) in diameter, when it is caused to pass through it. Each accumu-

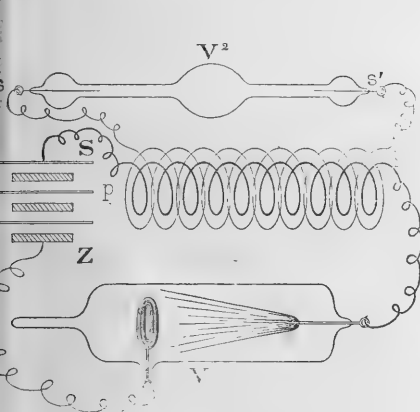

FIG. 3.

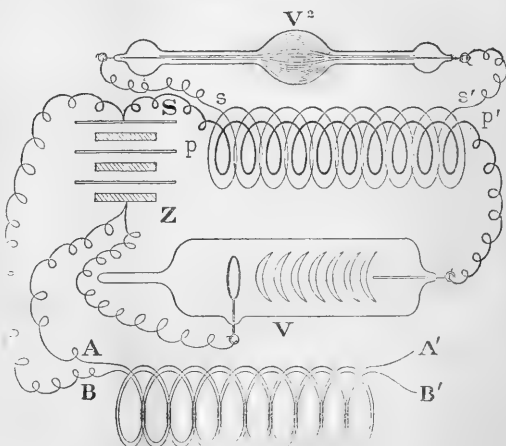

FIG. 4.

lator gives different results, but for the present we shall confine ourselves to a description of the experiments made with the coil accumulators.

When the terminals of the battery are connected with the wires of a vacuum-tube which permits of the passage of the current, the wires (especially that connected with the zinc end) become surrounded with a soft nebulous light, in which several concentric layers of different degrees of brilliancy are seen. In most cases there is either no indication of stratification or only a feeble ill-defined tendency to stratification; the tubes selected for these experiments were those in which the stratification did not appear at all.

When the battery, already in connection with the vacuum-tube, was also joined, as in Fig. 2, on to one or more coil-condensers (coupled to introduce a greater length of wire) in the following manner, then immediately well-defined stratifications appeared in the vacuum-tube.

S Z represents the battery, V the vacuum-tube, C the coil-condenser; one terminal is connected with the end A of the wire A A', and the other terminal with the end B of the second wire B B'; connections are also led to the wires of the vacuum-

tube. The ends A' and B' are left free; and it is clear that the coil forms a sort of Leyden jar when thus used; an interval, however short it may be, must elapse in accumulating a charge which at intervals discharges itself and causes a greater flow in the vacuum-tube in addition to that which passes continuously. It may be stated that the capacity of the accumulator has to be carefully adjusted to prevent any cessation of the current, to avoid, in fact, a snapping discharge at distant intervals. The periodic overflows, so to speak, which increase the current from time to time, would seem to have a tendency to cause an interference of the current waves, and to produce nodes of greater resistance in the medium, as evinced by the stratification which becomes apparent. To the eye no pulsation in the current is apparent; and in order to convince ourselves whether or not there was really any fluctuation in the current when the apparatus was thus coupled up with the battery, we made several experiments, and ultimately hit upon the following arrangement:—

The primary wire p p' of a small induction-coil, both with and without the iron core, was introduced into the circuit as well as the vacuum-tube V; to the secondary wire, s s', of the induction-coil was connected a second vacuum-tube, V<sup>2</sup>. Under these circumstances there was no change in the appearance of

<sup>1</sup> Journal of the Chem. Soc., Second Series, vol. vi. p. 488; Comptes Rendus, 1866, p. 794.

the discharge in V, in consequence of the introduction of the induction-coil, the terminals being still surrounded by the soft nebulous light before spoken of; no luminosity appeared in the second vacuum-tube, V<sup>2</sup>, in connection with the secondary wire of the induction-coil, except on making and breaking the connection with the battery. At other times there was evidently no fluctuation in the continuous discharge, no periodic increase or diminution of flow, and consequently no induced current in the secondary wire, s<sup>2</sup>, of the induction-coil.

In the second experiment wires were also led from the terminals of the battery (all other things remaining as before) to the coil accumulator, as in Fig. 4; then immediately the discharge in V became stratified, and the secondary vacuum-tube, V<sup>2</sup>, lighted up; clearly showing that under these circumstances a fluctuation in the discharge really occurs on the appearance of stratification.

The brilliancy of the discharge in V<sup>2</sup> (the induced current passes through complicated vacuum-tubes through which the primary current cannot pass) depends greatly on the quality and quantity of the discharge in the primary vacuum-tube, V. Under some circumstances the secondary discharge is extremely feeble, and the illumination in V<sup>2</sup> barely visible; under others it is very brilliant.

Preparations are being made to render evident induced currents in the secondary wire of the coil too feeble to produce any illumination. Pending the further development of our investigation, we have ventured to give an account of our progress in elucidating some points in the theory of the vacuum discharge, without any wish to ascribe to our results more weight than they deserve.

Batteries of this description may be had from Messrs. Tinsley and Spiller, Brompton Road. Their cost, in large numbers, is about one shilling per cell, exclusive of the charge of chloride of silver, which costs about two shillings per cell. The latter, either in the form of powder or of rods cast upon flattened silver wire, may be obtained from Messrs. Johnson and Matthey, Hatton Garden. When the battery is exhausted, the reduced silver may be readily reconverted into chloride with scarcely any loss.

Zoological Society, April 20.—Robert Hudson, F.R.S., vice-president, in the chair.—A letter was read from Lieut. R. J. Wardlaw-Ramsay, dated Tonghoo, British Burmah, 22nd November, 1874, containing additional remarks on the Woodpecker (*Geococcyx erythropygus*) described by him at a former meeting (P.Z.S. 1874, p. 212, pl. xxxv).—Mr. Edward R. Alston exhibited and made remarks on a rufous variety of the Murine Dormouse (*Graphiurus murinus*, Desm.) from West Africa.—Mr. W. B. Tegetmeier exhibited and made remarks on two hybrid pheasants, the result of a cross between *Phasianus colchicus* and *Euplocamus nyctemerus*.—Mr. A. H. Garrod read a paper on the structure of the deep plantar tendons in different birds, in which the different modes of arrangement of these tendons was pointed out, and their importance in the classification of the order insisted upon.—A communication was read from Mr. R. J. Lechmere-Guppy on the occurrence of *Helix coactiliata* in Trinidad, and on the general distribution of the land and freshwater mollusca of that island. A second communication from Mr. Guppy contained a note on a variety of *Bulinus contractus* found in Venezuelan Guiana.—A communication was read from the Rev. O. P. Cambridge, in which he gave descriptions of nine new species of spiders of the genus *Erigone* additional to those described in a former communication on the same subject.—A communication was read from Mr. George Gulliver, containing a description of the spermatozoa of the Lamprey, *Petromyzon marinus*.—Mr. R. B. Sharpe exhibited and made remarks on some specimens of some rare species of birds of prey lately received by the British Museum from Australia.

Entomological Society, April 5.—Sir Sidney Smith Saunders, C.M.G., president, in the chair.—Mr. Jenner Weir exhibited a number of young *Mantodea* that had emerged from an egg-case received from Ceylon.—Mr. Bond exhibited a specimen of an exotic locust taken alive at the bottom of a well near Brighton. Mr. Sealy read some notes on the habits of the species of *Ornithoptera* from the Malabar coast, exhibited at the last meeting.—Mr. McLachlan read a letter from an Englishman residing in Pueblo, Colorado, U.S., stating that from his experience of the potato beetle the insect could live on the tubers as well as on the haulm, and that unless the English authorities took some steps to prevent the importation of potato bulbs, he believed the beetles would soon be in this country.—Mr.

Edward Saunders communicated the first part of a Synopsis of British Hemiptera (Heteroptera).

## PARIS

Academy of Sciences, April 19.—M. Frémy in the chair.—The Secretary read a telegram from M. Janssen, dated Singapore, 16th April: "Eclipse observed; weather not absolutely fine. The results, specially those concerning the atmosphere of the corona, confirm those of 1871."—M. Ch. Sainte-Claire Deville then replied to the remarks made by M. Faye, at the last meeting, on M. Hildebrandsson's paper.—On the waterspout of Les Hayes (Vendôme) of Oct. 3, 1871, and the ravages produced by the same, by M. Faye.—On a great dust-fall observed in a part of Sweden and Norway, in the night of March 29-30, 1875, by M. Daurée.—On the observations made at the island of St. Paul by the Transit of Venus party, by M. Ch. Vêlain.—A (second) note by M. J. M. Gauguain on a theory of the processes of magnetisation.—A note by M. Donato Tommasi, on a new source of magnetism.—A note by M. de Boisbaudran, on the unequal solubility of the different planes of the same crystal.—On Japanese bronzes, a note by M. E. J. Maumené.—A note by M. Pagnoul, on the influence exercised by alkaline salts upon the vegetation of beet-root and potatoes.—On the equivalence of alkalis in beet-root, a note by MM. P. Champion and H. Pellet.—On the discovery of two new types of Conifera in the Permian schists of Lodève (Herault), by M. G. de Saporta; the names proposed for the new Conifera are *Ginkgoxyllum grassetti* and *Trichophyllum heteromorpha*.—M. J. François then addressed a communication to the Academy on the hydrothermal and saline emanations from the thermal sources in the Caucasus.—A number of gentlemen then made some communications with regard to Phylloxera.—M. J. Lichtenstein addressed a note on the insect mentioned by M. Holzner (not Helzenn, as was erroneously stated in the last *Compte rendu*), which lives on the roots of *Abies balsamea* and *Abies Fraseri*.—A note by M. Granjon on the means of increasing the sound of a bell by constructing the same of two concentric bells.—On the theory of storms; a reply to M. Faye, by M. H. Pésil.—A note on tartaric acid, which turns the polarisation plane to the right, by M. E. J. Maumené.—On the part played by Microzymata in the acid, alcoholic and acetic fermentation of eggs; reply to M. Gayon, by M. A. Béchamp.—On the therapeutic effect of oxygen, a note by M. Tamin-Despalle.—On a sepulchral retreat of the old Aleuts of Aknañ, on the Isle of Ounga, in the Shumagin Archipelago (Alaska), by M. Alph. L. Pinart.—On the ice conditions on the Danube in the winters of 1836 to 1875, by M. C. Champeiseau.—A note by M. Woillez, on the reproduction, in the lungs of a corpse, of the pulmonary sounds perceived during life by auscultation.

## BOOKS AND PAMPHLETS RECEIVED

FOREIGN.—Jahresbericht der Commission zur wissenschaftlichen Untersuchung der Deutschen Miere in Kiel, 1872-73: Dr. H. A. Meyer, Dr. G. Karsten, Dr. V. Hensen, Dr. G. Kupffler (Berlin: Wiegandt, Hempel, and Parey).—Revue Bibliographique Universelle. 2e série, 121 vol. (Paris, Bureaux du Polybiblion).—Discorso letto in occasione della festa Centenaria di Ambrogio Fusinetti, by Enrico dall' Pozzo di Mombello (Foligno, F. Sgariglia).—Verhandlungen der Naturforschenden Gesellschaft zu Freiburg, I.B. (Carl Troemer).

## CONTENTS

	PAGE
THE ISLAND OF ST. HELENA . . . . .	501
HEREDITARY, BY PROF. W. STANLEY JEVONS . . . . .	503
OUR BOOK SHELF:—	
Cleland's "Animal Physiology" . . . . .	504
Report of the Association for the Improvement of Geometrical Teaching . . . . .	504
LETTERS TO THE EDITOR:—	
Influence of Pigments on Photographic Image of the Spectrum.—W. J. STILLMAN . . . . .	505
Dr. A. B. Meyer and his Critics.—Dr. A. B. MEYER . . . . .	506
The Chesil Bank.—Thos. B. GROVES . . . . .	506
Flowering of the Hazel.—F. D. WETTERHAN . . . . .	507
OUR ASTRONOMICAL COLUMN:—	
The Total Solar Eclipse of 1715, May 3 . . . . .	507
The Transit of Venus, 1631, December 7 . . . . .	507
ARCTIC GEOLOGY, IV. BY C. E. DE RANCE, F.G.S. . . . .	508
THE PROGRESS OF THE TELEGRAPH, IV. (With Illustrations) . . . . .	510
THE "ZENITH" BALLOON ASCENT. BY W. DE FONVILLE . . . . .	513
LECTURES AT THE ZOOLOGICAL GARDENS . . . . .	513
NOTES . . . . .	514
EASTER WEEK AT THE SORBONNE . . . . .	516
SCIENTIFIC SERIALS . . . . .	518
SOCIETIES AND ACADEMIES . . . . .	518
BOOKS AND PAMPHLETS RECEIVED . . . . .	520









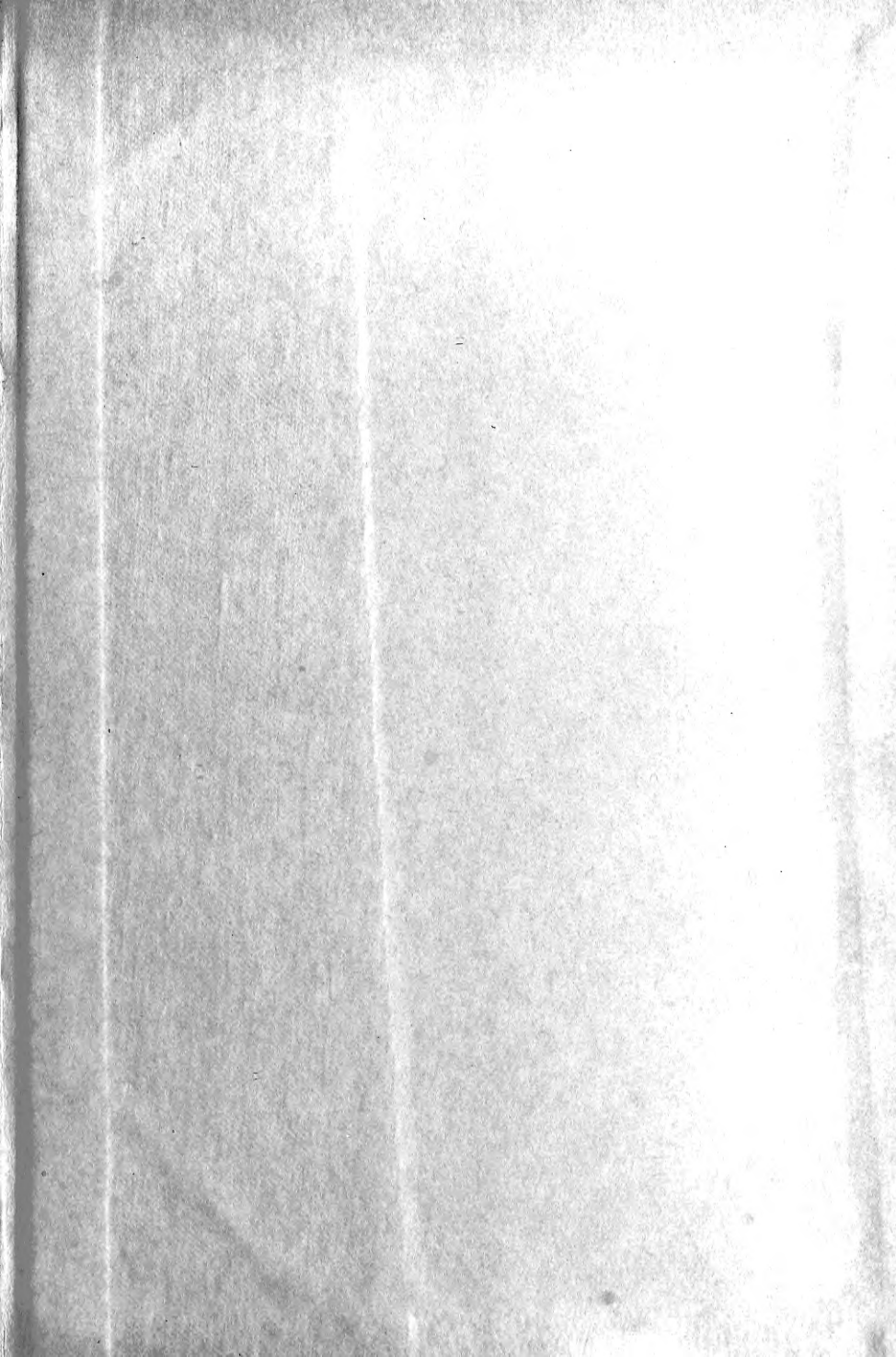



SMITHSONIAN INSTITUTION LIBRARIES



3 9088 01359 6085